



## Tractor-Mounted Inclined Lifts

*Robert “Bobby” Grisso, Extension Engineer, Biological Systems Engineering, Virginia Tech  
Don Ohanehi, Research Scientist, Engineering Science & Mechanics, Virginia Tech  
Kirk Ballin, Director, Program Coordinator, AgrAbility Virginia Project, Easter Seals UCP  
of NC and VA.*

### Introduction

Virginia AgrAbility program is assisting disabled farm workers to continue their work. As part of this program, we developed two types of mechanical lifts – vertical and inclined. In order to introduce these designs to potential users, Virginia AgrAbility developed the following three factsheets:

1. Tractor-mounted lifts
2. Tractor-mounted vertical lifts
3. Tractor-mounted inclined lifts

Factsheet #1 covers the general description of mechanical lifts including the different types that are available. In addition to safety considerations, Factsheet #1 discusses potential hazards while using mechanical lifts and the design criteria that need to be taken into consideration during the design.

The second and third factsheets describe the vertical and inclined mechanical lifts, respectively. Included in these publications are topics such as design considerations, design details, estimated cost, safety considerations and safe operating guidelines.

This factsheet specifically deals with a case study of the *Tractor-Mounted Inclined Lift*. Those who are interested in an inclined lift are encouraged to use Factsheets #1 and #3 simultaneously to gather the necessary information. When technical assistance is needed for the adaptation of this design, it may be sought by contacting the Virginia Department for Aging and Rehabilitative Services and Virginia AgrAbility. One may also go to (<http://www.agrability.org/>) for additional information.

### Inclined Lift Design Details

This factsheet provides design details for an inclined tractor lift designed specifically for placing a client on the driver’s seat of a Kubota L3400 tractor with a front-end loader. This design, however, can easily be altered to match similar utility tractors in the 30-75 hp range. The lift has an electric-motor driven lead screw (or ball screw) as actuator to take the lift seat up and down on two inclined rails mounted in front of the rear tire (Figures 1-4) on the side where steps are located. If desired, to keep the cost down, the actuator system may be replaced with a manually operated cable and winch system [Yoder et al.,

2000]. However, it must be noted that the cable-winch system may not be the ideal solution from a safety point of view.

## Construction Details

The lift configuration is very similar to the inclined lift shown in Factsheet #1, Figure 1k. The angle of inclination, however, is different because it is controlled by factors such as tractor height and spacing between front and rear tires and the mounting location (Figure 1). The mounting of the lift may also change depending on the tractor style. Therefore, it is important that the designer spend adequate time to develop the design criteria and determine which type of lift would be most appropriate and effective for the client. Certain lift designs may not be suitable for customization as others.

The designs must make use of off-the-shelf components whenever possible to save labor and cost. Most of the installation work will be required on the “Mounting Assembly.” To prevent rusting, use of stainless steel material or material with rust-free coating is encouraged. When rust prone parts are to be used, steps should be taken to minimize rust and corrosion.

## Mounting Frame

In order to keep the cost down, it is recommended that the lift frame be made of angle iron. The ideal location for mounting the lift frame is where front end loader assembly would be normally mounted. The rear mounted lift may be mounted along the side of the fender in which case, the removal of fender may be necessary. The location and mounting of the lift may vary depending on the make and model of the tractor. The lift design included in this factsheet is reasonably straight forward and a local machine shop should be in a position to fabricate it.

## Lift Seat

A standard seat, with pivoting arm rests on a swivel should work well for the lift (Figure 4). This will allow the operator to move in and out of the driver’s seat freely and safely. When mounting the seat, one must make sure that the seat will clear the rear tire while it travels up and down. The swivel selected for the seat system in the current design has a drawer slide to allow the operator to not only to turn freely 90 degrees, but also to slide forward to the tractor seat. The seat system also included arm rests, seat belt and a slide board to transfer the client from the lift seat to the tractor seat.

## Operating Instruction

- Each time, before use, inspect the lift to make sure that it is in working order. Verify that your cellphone is in good working order (for emergencies).
- Make sure the tractor engine is off and the wheel chair brakes are engaged before the person moves into lift seat.
- When occupying the lift seat, the occupant must be facing away from the tractor. The seat should be locked in position and the seat belt must be fastened.

### *For travel up:*

- Turn on the “on- off” switch on the lift. Then use “up” position switch on the hand control to let the seat move up.

- Turn the lift power switch off when the seat reaches the top.
- Unlock the seat-belt, turn the seat 90° clockwise to bring the lift seat parallel to the tractor facing forward. With the help of arms (if needed), the operator can lift the lower limbs over and past the lift railing, as he/she swivels. Lock the lift seat in the position.
- Fold down the right arm rest, turning it into a sliding board.
- Make sure the sliding board extends all the way and is supported by the tractor seat.
- Slide slowly and carefully to the operator's seat.
- With the seat-belt fastened, proceed with the tractor operation. Also, make sure that the tractor is clear of the wheelchair (if any) and other parked items near the bottom of the lift.

***For Travel Down:***

- Follow the instructions for *Travel Up* in the reverse order.

## **Lift Safety Considerations**

Safety is a major concern particularly when dealing with disabled workers. Extra caution is important for avoiding possible secondary injuries because they may have lasting and devastating impact on such workers. During the design and fabrication of lifts for disabled workers, safety issues associated with the user, machine, and environment must be considered (for additional information see references in the Resources section and VCE Publication on “*Tractor-Mounted Lifts*”). Clear maintenance and operating guidelines are extremely important and strict adherence to these guidelines by the user will also improve lift safety.

## **Cost Estimate**

The entire frame work for the lift except for the actuator and lift seat may be fabricated using less expensive angle or channel iron. The most expensive component of the system is the actuator (motor and lead or ball screw). Other components such as mounting hardware, the lift seat with swivel, and the lift controller are also somewhat expensive. The lift mechanism and the hand-held control system are designed to work with a 12 VDC battery available on a tractor. Even though the system is designed to be powered by the tractor battery, our experience shows that a battery fully dedicated for the operation of the lift and control system may be better. The estimate cost of the design (excluding labor) is between \$2,000-2,500.

## **Concluding Remarks**

Careful selection of lift type and proper location for mounting will help improve the effectiveness of the lift. Past experience has shown that when designing and fabricating a mechanical lift system for disabled farm workers, seeking professional assistance is appropriate.

## **WARNINGS AND DISCLAIMERS**

Reference to commercial products in this publication is strictly for informational purposes. Virginia Cooperative Extension is neither endorsing these products mentioned nor discriminating against other suitable products. Information included in this document is from the National AgrAbility Program and other reliable sources. However, neither the AgrAbility Program nor the authors of this document guarantee the accuracy of the information included in this document.

The purpose of this publication is to transfer general information to clients interested in selecting or designing a mechanical lift for heavy equipment such as a tractor. If and when engineering or other professional assistance is needed, one may contact appropriate state agencies and/or private consultants.

## References (all URL's accessed on June 11, 2018):

- Allen, P.B., W.E. Field, and M.J. Frick. 1994. Assessment of work-related injury risk for farmers and ranchers with physical disabilities. *J. of Ag Safety and Health* 1(2):71-81
- ASME. 2017. Safety Standards for Platform Lifts and Stairway Chairlifts. ASME Standard A18.1-2017. American Society of Mechanical Engineers. New York, NY.
- Ayers, P.D., C.A. Thomas, and M.A. Dickson. 1993, Unpublished report on two powered chairlifts, Colorado AgrAbility, Colorado State Univ., Department of Agric. and Chem. Engineering.
- Cook, A.M., and S.M. Hussey. 2002. Assistive Technologies: Principles and Practice, Mosby, 2<sup>nd</sup> edition, pp. 7-9.
- Grisso, R.D., D. Ohanehi, and K. Ballin. 2018. Tractor-mounted lifts. VCE Publication BSE-58NP (BSE-230NP), Virginia Tech, Blacksburg, VA. <https://pubs.ext.vt.edu/BSE/BSE-58/BSE-58NP.html>
- Grisso, R.D., D. Ohanehi, and K. Ballin. 2018. Tractor-mounted vertical lifts. VCE Publication BSE-59NP, Virginia Tech, Blacksburg, VA. <http://pubs.ext.vt.edu/BSE/BSE-59/BSE-59NP.html>
- Grisso, R.D., J.V. Perumpral, S.C. Mariger, D.E. Suttle, K. Funkenbush, and K. Ballin. 2014. Arthritis and Farming. VCE Publication 442-083 (BSE-139P), Virginia Tech, Blacksburg, VA. <https://pubs.ext.vt.edu/442/442-083/442-083.html>
- Grisso, R.D., J.V. Perumpral, and K. Ballin. 2014. Preventing secondary injuries in agricultural workplace. VCE Publication 442-085 (BSE-150P), Virginia Tech, Blacksburg, VA. <http://pubs.ext.vt.edu/442/442-085/442-085.html>
- Gruver, M.L., P.B. Allen, W.E. Field, and J. Schweitzer. 1997. Potential health and safety risks of farming/ranching with disability. Plowshares #27, Breaking New Ground Resource Center, Purdue University, West Lafayette, IN.
- Institute for Human Centered Design, *Universal Design*. <http://www.adaptiveenvironments.org/>
- Jepsen, S.D., and R.K. McGuire. 2010. Extending universal design principles onto the farmstead. ASABE Presentation and Paper No. 1009992. St. Joseph, MI: ASABE.
- Mariger, S.C., R.D. Grisso, J.V. Perumpral, A.W. Sorenson, N.K. Christensen and R.L. Miller. 2009. Virginia agricultural safety and health survey. *J. of Ag Safety and Health* 15(1): 37-47
- National AgrAbility website. <http://www.agrability.org/>
- North Carolina State University. 2008. Universal Design Principles. The Center for Universal Design, Raleigh, NC. [https://projects.ncsu.edu/ncsu/design/cud/about\\_ud/udprinciples.htm](https://projects.ncsu.edu/ncsu/design/cud/about_ud/udprinciples.htm)
- SAE J185. 2003. Access systems for off-road machines. SAE International surface vehicle recommended practice / ISO 2867-1980.
- Wray, C.L., S.C. Borgelt, H.W. Downs, and K. Funkenbusch. 2001. Accessibility Modifications to a Ford 4000 Tractor for a Farmer with a Spinal Cord Injury. ASABE Presentation and Paper No. 018054. St. Joseph, MI: ASABE.
- Yoder, A., W.E. Field, and G. Deboy. 2009. Proposed SAE standard for access systems on off-road machines for workers with disabilities. ASABE Presentation and Paper No. 090029. St. Joseph, MI: ASABE.
- Yoder, A., N. Stoller, and W.E. Field. 2000. New concepts in lift attachments for tractors and combines. Plowshares #8. Breaking New Ground Resource Center, Purdue University, West Lafayette, IN.

## National Resources:

AgrAbility National Project. <http://www.agrability.org/>

CoachLift. [www.coachlift.com](http://www.coachlift.com)

Disabled Dealer. <http://www.disableddealer.com>

Life Essentials. <http://www.lifeessentialsworld.com>

Foundation for Rehabilitation Equipment & Endowment (FREE). <http://www.free-foundation.org>

National Center for Chronic Disease (CDC) Prevention and Health Promotion. <http://www.cdc.gov>

## Virginia Resources:

Centers for Independent Living (CIL's) <http://www.brilc.org/>

Virginia Department for Aging and Rehabilitative Services <https://www.vadars.org/>

Easter Seals North Carolina and Virginia UCP <http://nc.eastersealsucp.com/>

Virginia AgrAbility Project <http://www.agrability.ext.vt.edu>

Virginia Assistive Technology Partnership (VATS) <http://www.vats.org/>

Virginia Disability Service Agencies <http://www.vadsa.org/>

Virginia Farm Bureau Safety (FB) <http://www.vafb.com/>

Wilson Workforce and Rehabilitation Center (WWRC) <http://www.wwrc.net/>

## Acknowledgments

The authors would like to express their appreciation for inputs from: Dr. Paul Ayers, University of Tennessee, Knoxville, TN; Dr. Gail Deboy, Purdue University Ag Safety Specialist, West Lafayette, IN; Dr. Aaron Yoder, Pennsylvania State University, University Park, PA; John Perumpral, Professor Emeritus, Department of Biological Systems Engineering, Virginia Tech, and application engineers from Danaher Motion Controls, Radford, VA. The authors also acknowledge the design contributions of John Massale, and JD McCoy, Biological Systems Engineering, Kristianne Macaraeg, Chemical Engineering, and Jeremy Smith, Mechanical Engineering, Virginia Tech.

This factsheet resulted from an Extension Project (project number 2006-41590-03436) supported by the Cooperative State, Research, Education, and Extension Service (CSREES) of U. S. Department of Agriculture.

## Inclined Lift Sketches:

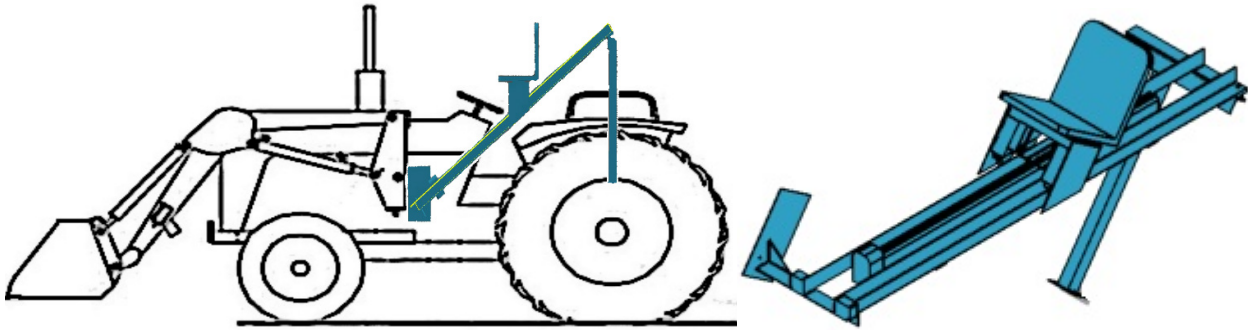

Figure 1. Inclined lift, side-view with the tractor. Note: Dimensions are approximate.

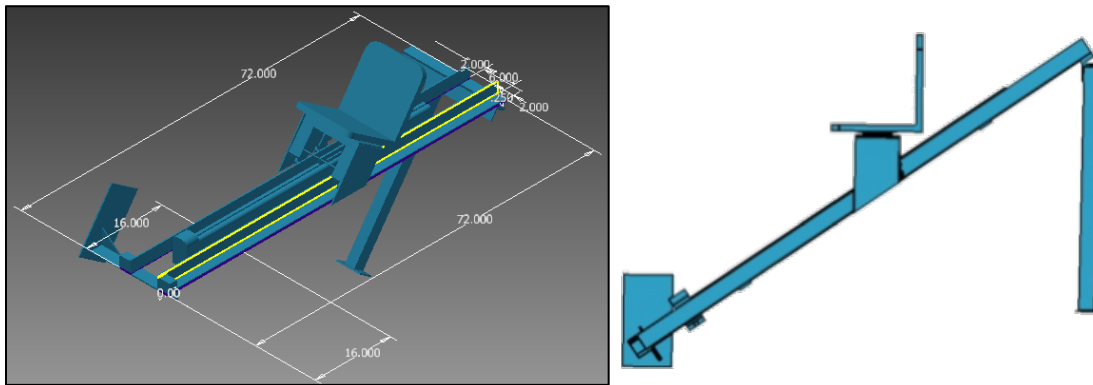

Figure 2. The inclined lift, side-view (top, left), front and rear mounting plate-top, view (side, right). Note: Dimensions are approximate.

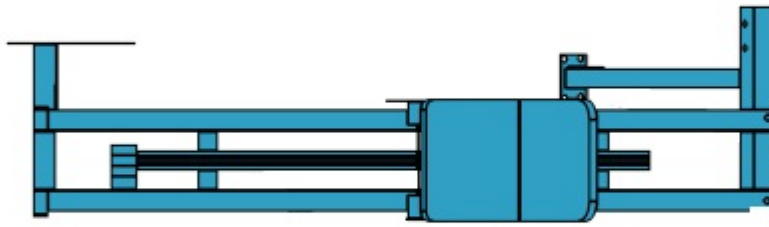

Figure 3. Inclined rail and actuator (black element), underneath rail assembly (top view). Note: angle of inclination removed.

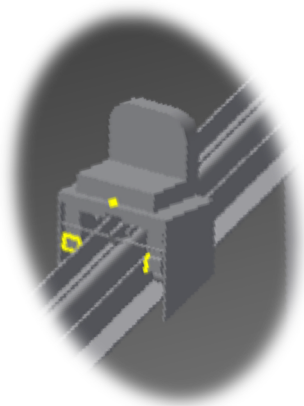

Figure 4. Carriage, seat support details, front-view of a caster (yellow), carriage support for seat, side-view (middle), carriage details and swivel for seat, front-view (bottom). Note: Dimensions are approximate.