

L.D.  
5655  
A 761  
NN 101  
no. 55  
c. 2

V.P.I. & S.U. LIBRARY

SEP 5 1978

BLACKSBURG, VIRGINIA



# SCIENCE CLUB 2

---

**Extension Division**  
**Virginia Polytechnic Institute**

---

# Hi, 4-H TV Club Members!

WELCOME to an exciting world of science and challenge. The fun you will have as a member of the 4-H TV SCIENCE CLUB is limited only by the amount of time and energy you are willing to give it. If this is your first experience with 4-H, I think you'll be pleasantly surprised at how much it can offer a boy or girl in any type of community.

You will find three things in your project manual:

1. Basic information about 4-H. (Also, information about the members of the 4-H TV Science Club program.)
2. Experiments and projects for you to do as an individual or with your club.
3. A report form for you to fill out when your projects are completed.

Remember, the fun of 4-H lies in *doing things*, not watching other people do them. So get busy and have a good time. I know you'll enjoy it.

**Jim Culver**  
*4-H TV Club Leader*

## What is 4-H?

Boys and girls organize a club with their own elected officers and "learn by doing" under the guidance of a local 4-H leader. The members attend meetings, carry out projects and take part in programs. They also participate in other 4-H activities, camps, achievement days, tours, fairs and exhibits, and demonstrations.

**MOTTO:** "To Make the Best Better"

**COLORS:** Green and White

**PLEDGE:** *I pledge*

*my Head to clearer thinking,  
my Heart to greater loyalty,  
my Hands to larger service,  
my Health to better living,  
for my home, my club, my community,  
and my country.*

## PROJECTS:

Each club member is expected to complete at least one project, and show that project during his local 4-H achievement day. It might be well to ask for some help from your parents, your club leader, or perhaps your science teacher.

M-4-H-55 Cooperative Extension Service October 1969

Issued in futherance of Cooperative Extension work, Acts of May 8 and June 30, 1914, in cooperation with the U. S. Department of Agriculture. W. E. Skelton, Dean, Extension Division, Cooperative Extension Service, Virginia Polytechnic Institute, Blacksburg, Virginia 24061

Most of the exercises described in this project manual will cost very little.

You can buy materials you need at the hardware store, hobby shop, lumber company, drug store, or chemical supply house. Most 4-H'ers like to "improvise" by using scrap lumber, old bottles (for test tubes), etc.

## Who Can Be a 4-H Member?

All boys and girls from about 9 to 19 years of age may join 4-H. There are over two million 4-H members in the United States, so invite your friends to watch the 4-H TV Science Club program with you. Then you can organize a 4-H Club in your community.

You can all work together on your projects, play games, and plan a tour for your own group. You'll want to ask an adult to serve as your 4-H Club leader. A good place to start might be with Mom and Dad. Just have them watch the program right along with you and your friends.

Your County Extension Agent will be happy to assist you in forming your own club, or in obtaining information about 4-H in your area.

## Who Appears on the 4-H TV Program?

The two girls and three boys appearing on the 4-H television program were carefully screened from many applicants. Their names and ages are as follows:

*Karn Weirman, 11                      Gram Gal, 10  
Maureen Keeney, 9                    Rex Gates, 11  
David Gillespie, 11*

Jim Culver has served on two other 4-H TV series, the *4-H TV Electrical Club* and the *4-H TV Science Club (I)*. A specialist in children's programs, Jim is employed as a television producer by WMSB, the educational television station of Michigan State University. His hobbies include water skiing, skin diving, and photography.

## Contents . . .

Fire .....	1	Physics .....	12
Animals .....	3	Behavior .....	14
Astronomy .....	5	Microbiology .....	16
Plants .....	8	Meteorology .....	18
Archeology .....	11	Chemistry .....	21

**Meeting No. 1:**

# The Science of Fire

**CAUTION**  
While conducting experiments with fire, keep in mind that a true scientist would **NEVER PLAY WITH FIRE** any more than he would play with an explosive chemical. Observe all safety precautions while conducting any experiments. In fact, you might ask Mom or Dad to look over your shoulder, just as a scientist might invite the assistance of his supervisor.

**PROJECT NO. 1: *Make Carbon Dioxide***

**MATERIALS**

1. Wide-mouth glass jar
2. Baking soda
3. Small piece of candle
4. Vinegar

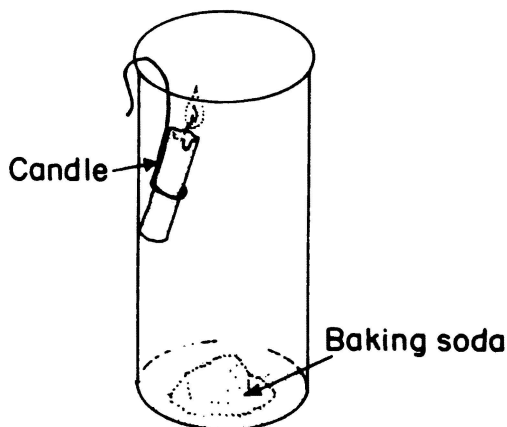

**PROCEDURE**

1. Place spoonful of baking soda in glass jar.
2. Attach lighted candle to wire and suspend in jar.
3. Pour small amount of vinegar on baking soda.

**RESULTS**

Carbon dioxide is formed by the action of vinegar on baking soda. When carbon dioxide reaches the lighted candle the flame goes out.

**PROJECT NO. 2: *Make a Fire Extinguisher***

**MATERIALS**

1. Baking soda
2. Cocoa can or any small can with removable top



**PROCEDURE**

1. Punch 10 or 12 one-quarter-inch holes in top of can.
2. Fill can with baking soda.
3. Shake baking soda from can onto fire.

**RESULTS**

Fire goes out due to: (a) air is removed from burning material; (b) carbon dioxide is formed when baking soda is heated; (c) carbon dioxide will not support combustion and fire goes out.

## The Science of Fire . . .

### PROJECT NO. 3: Make a Fire Extinguisher

#### MATERIALS

1. Wide-mouth glass bottle with stopper to fit
2. Three inches of one-quarter-inch glass, metal or plastic tubing (use tube from old Windex bottle)
3. Spoonful of baking soda
4. Vinegar
5. Tissue paper

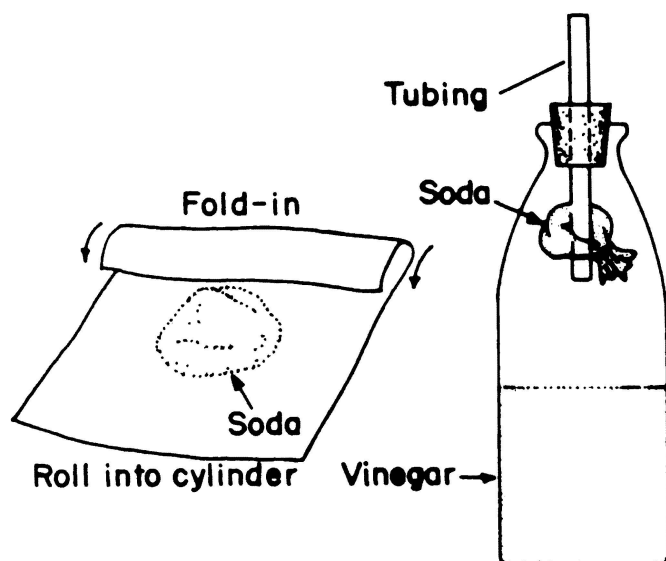

#### PROCEDURE

1. Drill hole in stopper and insert tubing.
2. Wrap soda in tissue and attach package to tube with rubber band.
3. Fill bottle one-half full of 1 part vinegar and 1 part water.
4. Insert stopper in bottle with soda inside bottle, but not touching vinegar solution.
5. To operate, tip bottle upside down, soaking the tissue paper with vinegar.

#### RESULTS

Water-vinegar solution puts out fire.

### PROJECT NO. 4: Make a Fire with Sticks

#### MATERIALS

1. Curved stick with bowstring
2. Fire drill of cedar or hardwood
3. Handle for top of drill made of stone or metal (Make socket for top of drill.)
4. Fire board of soft wood with beveled hole and socket to side of board
5. Shredded dry bark

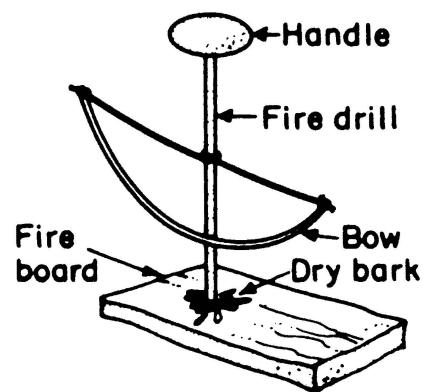

#### PROCEDURE

1. Set up equipment as shown in diagram.
2. Work bow back and forth rotating drill rapidly.
3. When bark starts to smoke, blow gently on it until flame appears.

#### RESULTS

Friction of rotating drill heats bark to kindling point. Bark starts to burn.

## Meeting No. 2:

# The Science of Animals

## (Skeletons)

### PROJECT NO. 1: *Study Life History of Insects*

#### MATERIALS

1. Jam jar
2. Shoe box
3. Smaller jar for water

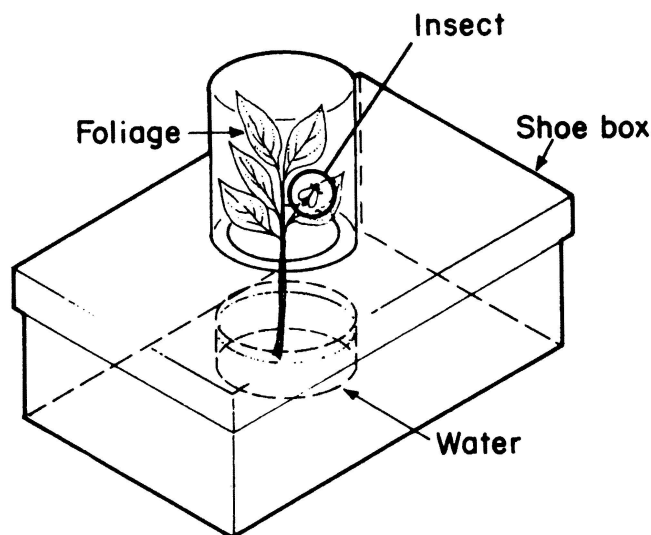

#### PROCEDURE

1. Place blow fly (large green fly) or other insect in jam jar as indicated in diagram.
2. After eggs have been laid on piece of refuse or leaves, place eggs in warm sun. Eggs will hatch in about 1 week.
3. Eggs hatch into worms.
4. Provide damp moss to prevent them from drying up.

#### RESULTS

Complete life cycle can be followed in a few weeks.

### PROJECT NO. 2: *Preserve Insects in Plastic*

#### MATERIALS

1. Clear liquid plastic with hardener (purchased from laboratory supply company)
2. Mold ( $\frac{1}{2}$  inch larger than insect) glass with rounded bottom (wipe inside of glass mold with glycerine)

#### PROCEDURE

1. Add hardener to liquid plastic (about 1 tablespoon resin to 5 drops of hardener—see directions on container).
2. Pour plastic in mold.
3. Place insect in plastic.
4. Pull out tiny air bubbles with toothpick.
5. Allow to harden.

#### RESULTS

Plastic-imbedded insect

### PROJECT NO. 3: *Collect Insects*

#### MATERIALS

1. Net (lightweight, fine mesh)
2. Boxes (for storing)
3. Pins
4. Collecting bottles or jars
5. Killing jar (with cotton saturated in lighter fluid)







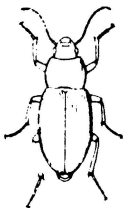

#### PROCEDURE

1. Net insect and place in killing jar.
2. Mount on pins. Wings should be extended to show coloration.

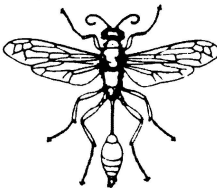
#### RESULTS

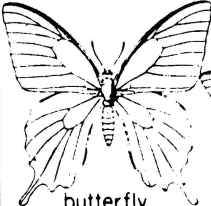
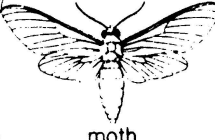
A neat, orderly collection showing various types of insects; where they are found, etc.

*The Science of Animals . . .*

<b>Coleoptera</b>		<b>Hymenoptera</b>	
 longhorned beetle	 ground beetle	 ant	 thread-waisted wasp
 ladybird beetle		<b>Lepidoptera</b>	
		 butterfly	 moth
<b>Diptera</b>	<b>Hemiptera</b>	<b>Odonata</b>	<b>Orthoptera</b>
 horse fly	 squash bug	 dragonfly	 praying mantis

**INSECT CLASSIFICATION KEY**

**PROJECT NO. 4:** *Show Stages of Development of a Frog (egg, tadpole, frog)*

**MATERIALS**

1. Wide-mouth glass jars
2. Alcohol
3. Killing jar with cotton saturated in lighter fluid

**PROCEDURE**

1. Collect eggs, tadpoles and frogs.
2. Place tadpoles and frogs in killing jar for 10 or 15 minutes.
3. Fill collecting jars with alcohol and place specimens in jars.
4. Seal jars tightly so that alcohol will not evaporate.

**RESULTS**

Collection showing metamorphosis (change in form) of frog

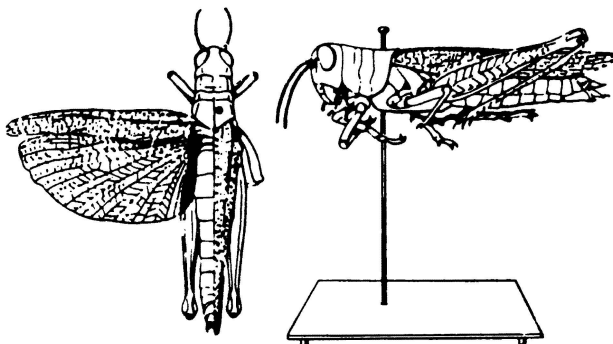

**Meeting No. 3:**

# The Science of Astronomy

## (Time Keeping Projects)

**PROJECT NO. 1: *Make an Hourglass***

**MATERIALS**

1. Conical paper cups
2. Wire coat hanger

Top cup receives dry sand

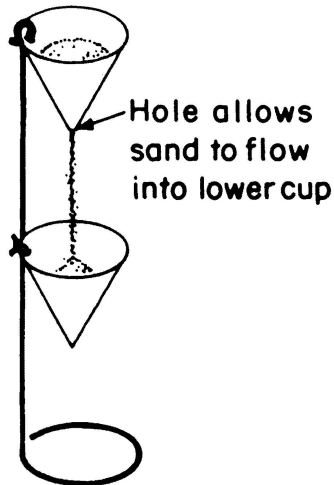

**PROCEDURE**

1. Bend coat hanger to form a stand for 2 of the paper cups.
2. Top cup has a small hole in the bottom.
3. Dry sand is placed in the top cup and a measured unit of time has elapsed when all the sand has dropped into the bottom cup.

**PROJECT NO. 2: *Make a Shadow Stick***

**MATERIALS**

1. Stick (three feet long, or longer)

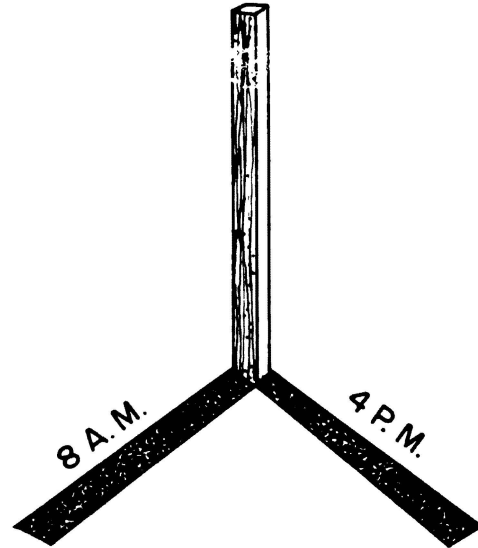

**PROCEDURE**

1. Place stick in ground in open space and in sunlight.
2. Measure the length of the shadow in morning, noon and evening.
3. Figure out how you can use the stick to measure time.

## The Science of Astronomy . . .

### PROJECT NO. 3: To Make a Sundial

#### MATERIAL

1. 2 pieces of thin wood about 12 inches square

#### PROCEDURE

1. Cut out right triangle for ganon or pointer stick.

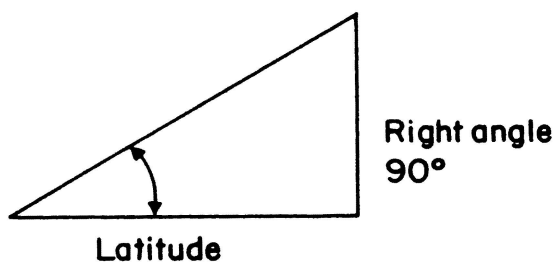

This angle must be equal to the latitude of the town in which you live. You can find the latitude by looking at a map or globe.

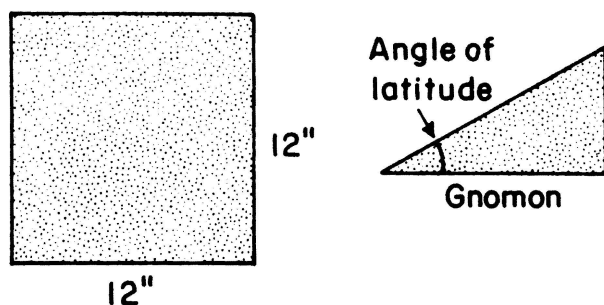

2. Mount ganon or pointed stick on 12-inch base.
3. Put your sundial outdoors in sunlight.
4. Point the upright side of the ganon to the north.
5. At each hour of the day, mark the position of the shadow and the number of the hour.

### PROJECT NO. 4: Make a Simple Astrolabe

#### MATERIALS

1. Protractor
2. Soda straw
3. Wooden rod (about  $\frac{3}{4}$ " x  $\frac{3}{4}$ " x 4")
4. Baseboard (about 6" square of  $\frac{1}{2}$ " plywood)

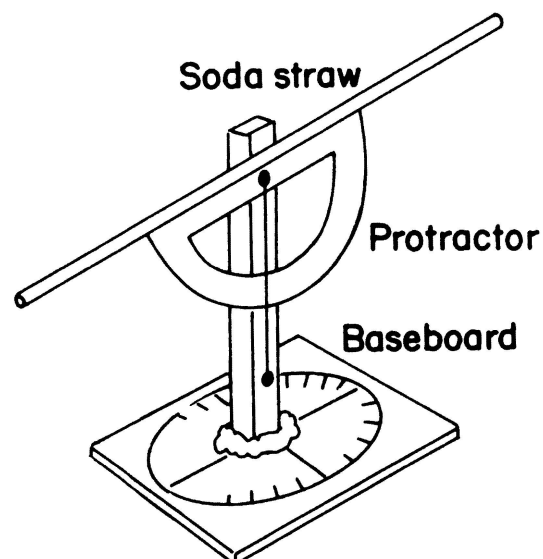
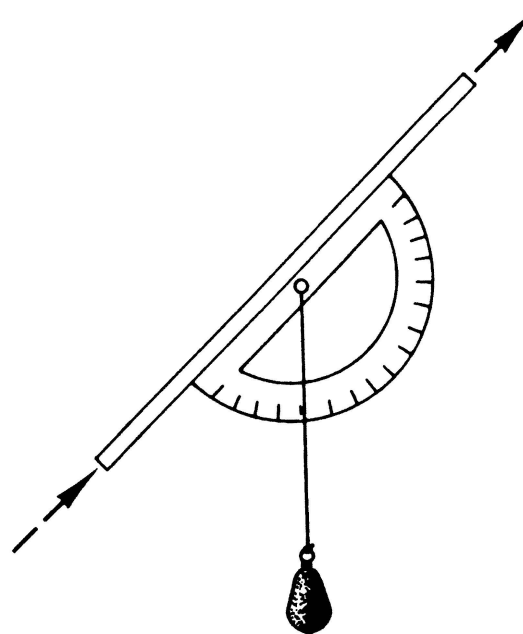

#### PROCEDURE

1. Fix soda straw to base of protractor with sealing wax or glue.
2. Attach wooden rod to baseboard with one screw so that the rod will turn.
3. Attach protractor and soda straw to top of rod with one nail or screw as shown in diagram.
4. Attach plumb line to nail.

#### RESULTS

Sight in the North star through the drinking straw and the weighted string will fall across the figure on the protractor corresponding to the latitude of the observer. By reversing the procedure, one can tell time with the stars.



**PROJECT NO. 5: *Make a Simple Telescope***

**MATERIALS**

1. Lens from linen tester, stamp magnifier or any small lens with focal length of about 1-inch (eye piece)
2. Object glass with focal length of about 10 inches (objective lens)
3. Two mailing tubes (one slightly smaller so that it will fit inside larger tube)

**PROCEDURE**

1. To get the focal length of a lens, stand near a wall and opposite a window. Hold lens up and focus image of window on wall. The distance at which you get the smallest sharp image is the lens focal length.
2. Mount lenses in mailing tubes as shown in diagram.
3. Focusing is done by sliding the tube in and out.

**PROJECT NO. 6: *Star Trail Photography***

**MATERIALS**

1. Camera
2. Tripod or other solid base to attach camera

**PROCEDURE**

A child and a parent interested in photography can take time exposures of stars.

1. Place the camera on a slide base and point it toward the North star.
2. Select a clear moonless night.
3. Make the camera aperture as small as possible.
4. Protect the camera from car headlights, etc.
5. Expose the film for several hours.

**RESULTS**

Your photography should show one apex of the axis on which our earth turns.

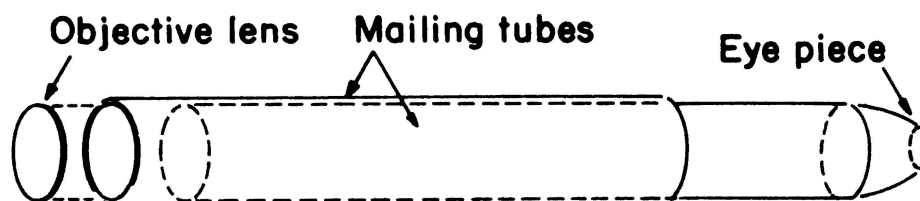

## Meeting No. 4:

# The Science of Plants

### PROJECT NO. 1: *Find Out What is Inside a Garden Bean Seed*

#### MATERIALS

1. Several garden bean seeds
2. Saucer

#### PROCEDURE

1. Place several garden bean seeds in a saucer, cover with warm water and let stand overnight in a warm place.
2. Gently remove the seed coat the next day and pull the two cotyledons (kot-i-le-duns) apart.
3. Look at the young leaves and root of the tiny plant or embryo (em-bree-o).

#### RESULTS

If the cotyledons are spread apart carefully, the young leaves and root can be seen.

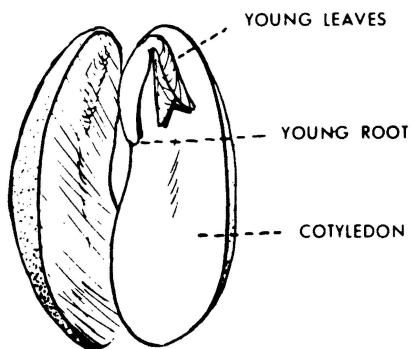

### PROJECT NO. 2: *Demonstrate the Force of Germinating Seeds*

#### MATERIALS

1. Enough garden bean, pea, or corn seeds to fill two small vials or bottles.
2. Two small vials or bottles with corks.

#### PROCEDURE

1. Fill both vials or bottles with seeds.
2. Pour warm water over the seeds in one bottle.
3. Put a cork in each bottle—don't use a screw cap.
4. Check the bottles each hour.

#### RESULTS

Within an hour or two, the germinating seeds in the bottle with water will force the cork out the top. If a screw top is used, the germinating seeds will often burst the bottle.

### PROJECT NO. 3: *Demonstrate How Roots and Stems Respond to Gravity*

#### MATERIALS

1. Four corn grains
2. One paper towel
3. One plain glass tumbler (water glass)

#### PROCEDURE

1. Place a paper towel inside the glass.
2. Place four corn grains as shown below between the paper towel and the inside of the glass.
3. Place two inches of warm water in the glass.
4. Place the glass in a warm location such as in the kitchen.

#### RESULTS

The seeds will germinate. The roots should emerge first and grow down and the stems should emerge later and grow up. The roots and stem respond this way because of gravity – not because of where the water is or where the light is. This response is called geotropism (gee-oh-trop-is-um).

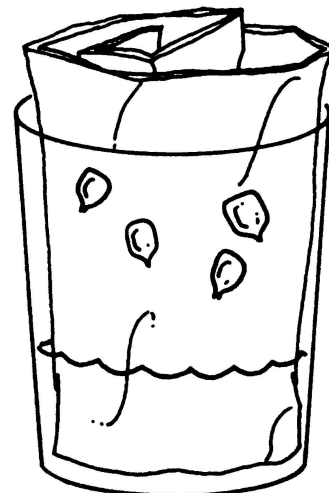

**PROJECT NO. 4:** *Demonstrate That Stems of Plants Grow Toward Light*

**MATERIALS**

1. Two cardboard boxes
2. Several seeds of radish, corn or garden beans
3. Two paper, plastic, or glass cups
4. Two cupfuls of sand

**PROCEDURE**

1. Soak several seeds of radish, corn, or beans overnight and then plant half of them in one cup just under the surface of the sand and the other half in the other cup.

2. Place one cup with the seeds in a light-tight cardboard box and the other cup in a box with a slit or hole in it at the level of the top of the cup.

**RESULTS**

Within a few days, the stems of the plants in the box with the hole in it will be bending toward the light (phototropism, pronounced fo-to-trop-is-um) while the stems of plants grown in the light-tight box will be growing straight up.

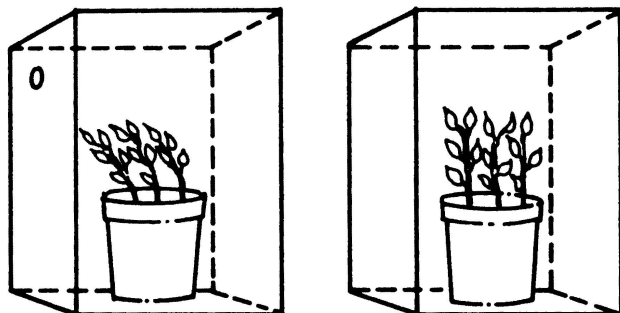

**PROJECT NO. 5:** *Find Out What Parts of Plants You Eat*

**MATERIALS**

1. Common vegetables used in meals

**PROCEDURE**

1. Given the information below, figure out what parts of plants you eat for dinner for one week.

The four main parts of plants and common examples of each are:

**Roots**—Sweet potato, carrot

**Stems**—White potato (a specialized underground stem called a tuber), kohlrabi

**Leaves**—Spinach  
Leaf stalk—Celery

**Flowers**—Broccoli (the young flowers and stems)  
**Fruits**—Cucumbers, squash, green beans  
**Seeds**—Lima beans, peas, rice, dill

We also eat buds, for example, cabbage.

**RESULTS**

You will learn the part of the plant that you eat.

**PROJECT NO. 6:** *Demonstrate the Movement of Water in Plants*

**MATERIALS**

1. One stalk of celery
2. One water glass
3. Colored dye or ink

**PROCEDURE**

1. Fill the glass with water.
2. Add colored dye or ink (red, black, or blue) to the glass.
3. Cut off about ½ inch off the bottom of the celery stalk and place it in the glass.

**RESULTS**

The leaves will lose water by transpiration which in turn creates a pull that will suck the water up the stalk into the leaves. You should be able to see the coloring in the leaves. The veins in the stalk (the strands you commonly get caught in your teeth) actually conduct the water and you should be able to see this if you cut the stalk off and look for the colored areas.

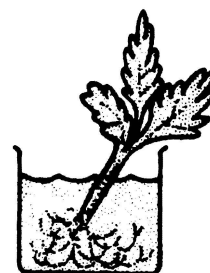

**PROJECT NO. 7:** *Make a Miniature Greenhouse*

**MATERIALS**

1. Low, flat container such as a cake pan, half-gallon milk carton, (cut in two the long way) plastic container or a clay flower pot
2. Small stakes or stiff wire such as a coat hanger
3. Sand

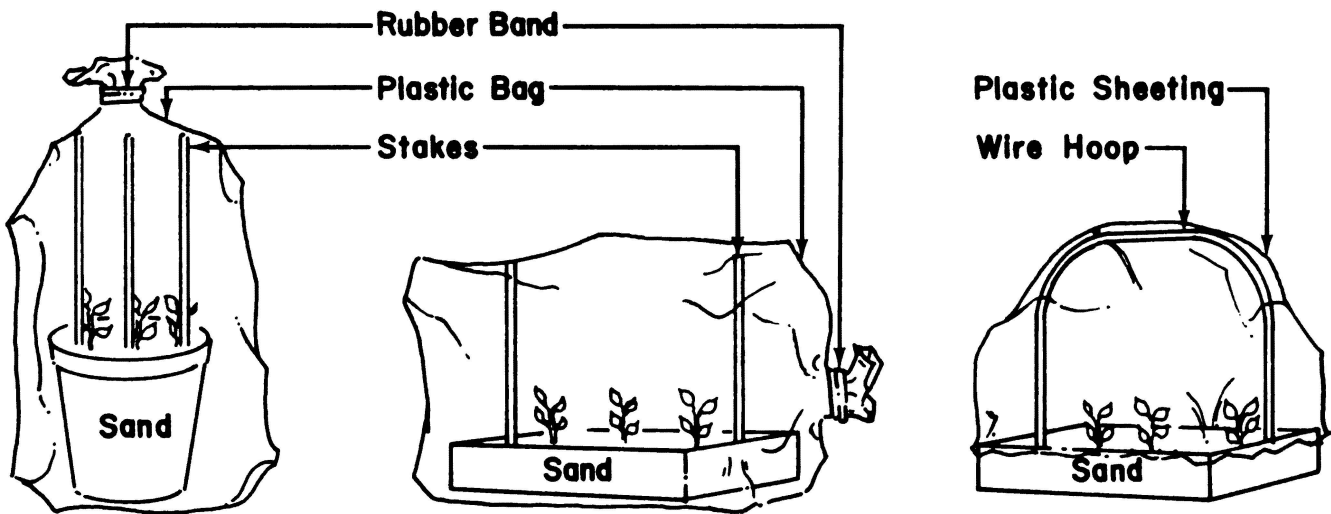

### PROCEDURE

1. Fill the container with sand. If you use a flower pot, cover the drainage hole with a rock or piece of broken pot to keep the sand from washing out.
2. Put 12-inch stakes in each corner or around the pot or make wire hoops to hold up the plastic.
3. Cover the containers with plastic or make or use a large plastic bag and slide the container in it and then close the end of the bag with a rubber band.

### RESULTS

You end up with a miniature greenhouse suitable for starting plants from seeds or cuttings.

rooting hormone on the stem bases to make the cuttings root faster. Such a hormone can be purchased at a garden store.

3. After the cuttings have rooted, pot them in a sandy loam soil and water them.

### RESULTS

Cuttings will root in three to six weeks resulting in new plants.

### PROJECT NO. 8: *Propagate Plants by Cuttings*

#### MATERIALS

1. Miniature greenhouse from project 7
2. Cuttings of coleus, geranium or other house plants

#### PROCEDURE

1. Make cuttings of coleus or geranium stem tips about three to four inches long.
2. Place the base of the stem in the sand about one to two inches deep. You will probably have to break off a few of the bottom leaves. You may want to use a

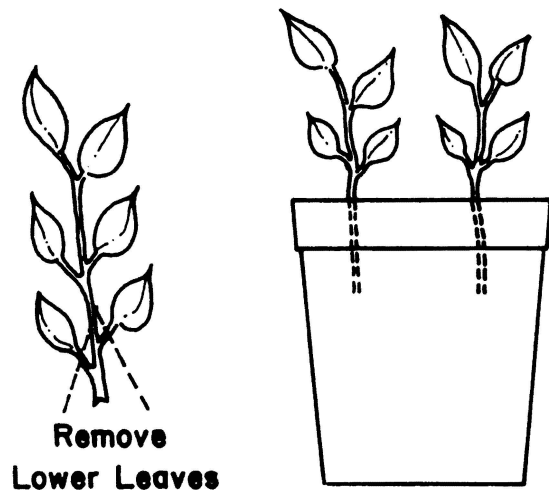

## Meeting No. 5:

# The Science of Archeology

### PROJECT NO. 1: *Make a Grid Map of Your Back Yard*

#### MATERIALS

1. Ball of string
2. Stakes
3. Measuring tape (yardstick)
4. Graph paper or any paper marked off in squares

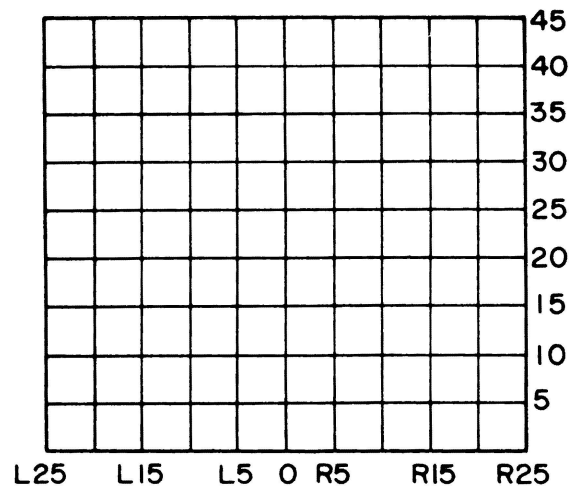

#### PROCEDURE

1. Measure off back yard into five-foot squares using stakes and ball of string.
2. Locate trees, shrubs and flower gardens on graph paper from squares marked off with string and stakes.

#### RESULTS

Grid map of back yard

### PROJECT NO. 2: *Show How Fossils Are Formed*

#### MATERIALS

1. Vaseline
2. Pane of glass or smooth surface
3. Plaster of Paris
4. Leaf or shells

#### PROCEDURE

1. Cover leaf or shell with vaseline.
2. Place leaf flat on smooth surface.
3. Mix plaster of Paris and pour it over leaf.
4. When plaster has hardened, remove the leaf or shell.

#### RESULTS

You will have an excellent imprint of leaf or shell. Some fossils are formed this way.

### PROJECT NO. 3: *Make Artifacts (String of Indian beads)*

#### MATERIALS

1. Plaster of Paris
2. Plastic bottle caps (do not use the screw-on type of cap) or any very small container with smooth sides that can be used as a mold

#### PROCEDURE

1. Put thin coat of vaseline or cooking oil on inside of mold.
2. Mix Plaster of Paris in water to thick soup.
3. Pour in molds and allow to harden.
4. Remove from mold and drill hole for string.
5. Paint beads with water colors.

#### RESULTS

String of Indian beads.

#### OTHER PROJECTS:

4. Collection of maps and pictures of historic landmarks.
5. Visit museum—study artifacts.
6. Build cardboard or wooden model of fort or historic landmarks in your area.

## Meeting No. 6:

# The Science of Physics

## (Air Pressure)

### PROJECT NO. 1: *Show that Air Exerts Pressure in All Directions*

#### MATERIALS

1. Drinking glass full of water
2. Piece of cardboard

#### PROCEDURE

1. Fill drinking glass with water.
2. Place a piece of cardboard over glass.
3. Hold cardboard against glass and turn it upside down.
4. Take away hand holding cardboard.

#### RESULTS

Air pressure holds water in glass.

### PROJECT NO. 2: *Lift Water with Air Pressure*

#### MATERIALS

1. Tall drinking glass
2. Pie plate
3. Candle

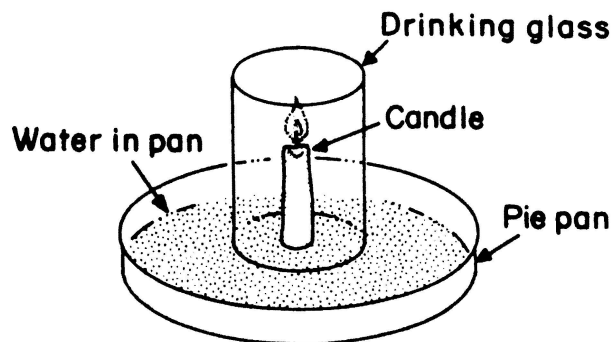

#### PROCEDURE

1. Fasten small candle to middle of pie plate with hot wax.
2. Fill pie plate with water
3. Light candle.
4. Place empty drinking glass over candle.

#### RESULTS

As candle burns oxygen out of air in glass, the air pressure pushes water up in glass.

### PROJECT NO. 3: *Make a Compressed Air Pop Gun*

#### MATERIALS

1. Straight piece of plastic tubing (about 1-inch diameter)
2. Straight wooden stick
3. String
4. Cork to fit end of plastic tubing

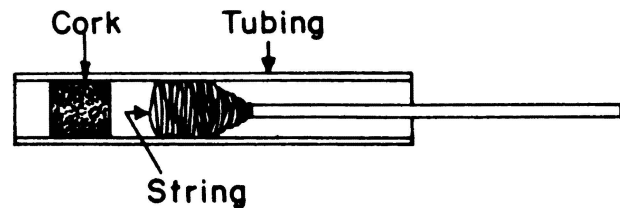

#### PROCEDURE

1. Make piston by winding string on stick till it fits tightly in tubing.
2. Put cork in end of tube and push piston quickly.

#### RESULTS

Air in tubing is compressed forcing cork out of tube.

**PROJECT NO. 4: *Build an Air Car***

**MATERIALS**

1. Three-inch by three-inch piece of half-inch plywood
2. One-inch length of metal tubing (about 3/8-inch diameter)
3. Large rubber balloon

**PROCEDURE**

1. Drill hole halfway through and in exact center of plywood for metal tubing.

2. Finish drilling through plywood with 1/16-inch drill.
3. Cement tubing in hole.
4. Round edges on bottom of plywood.
5. Taper 1/16-inch hole on bottom.
6. Sand on wax bottom.
7. Blow up balloon, attach to tubing and place car on smooth surface.

**RESULTS**

Air pressure lifts car off smooth surface.

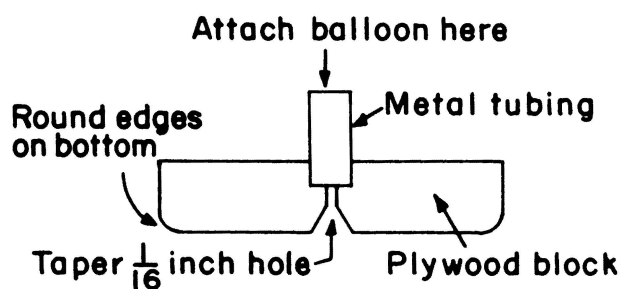

## Meeting No. 7:

# The Science of Behavior

### PROJECT NO. 1: *Scientifically Test or Measure a Hypothesis (Idea)*

#### MATERIAL

1. Drawing

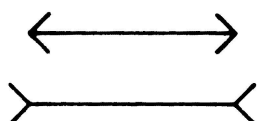

#### PROCEDURE

Ask your friends to look at the straight lines and tell you which line is the longest. Take a ruler and measure the lines.

#### RESULT

Things are not always as they seem, proving the need for scientific analysis.

### PROJECT NO. 2: *Study Illusions*

#### MATERIAL

1. Drawing

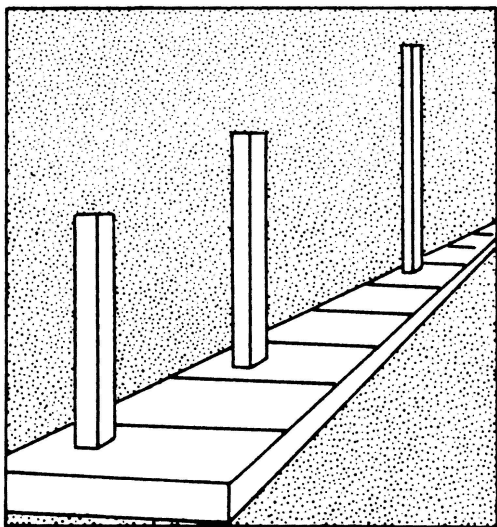

#### PROCEDURE

Which post do you think is the longest? Measure the posts. Were you right?

#### RESULT

Probably not, since the artist has played a trick on us by drawing the design in a way in which we are not accustomed to seeing them; that is, as we look down a railroad track, the telephone poles alongside should appear smaller . . . even though they are all the same size.

### PROJECT NO. 3: *Check Observations (Seeing is believing—or is it?)*

#### MATERIAL

1. Sign

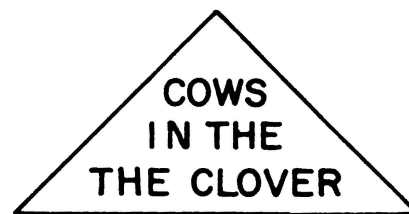

#### PROCEDURE

Ask a friend to read the sign aloud.

#### RESULT

He will probably skip the second “the” since most of us read groups of words rather than one word at a time. The first message received by our mind after reading the sign is called an “illusion.”



**PROJECT NO. 4:** *Study Observation and Perception Through the Use of Codes and Ciphers*

**PROCEDURE**

Read the sentence printed below. What is the best and easiest way to read this kind of a cipher?

**IS A PUZZLE UNSOLVED  
PUZZLE SOLVED, AND EVERY QUESTION  
EVERY SCIENTIFIC DISCOVERY IS A**

Here is another type of cipher: How can you arrange these groups of letters to spell out the message: "They have gone home."?

THGH, HAOO, EVNM, YEEE

**RESULT**

You and your friends can send messages in secret codes. Make up your own.

## **Meeting No. 8:**

# **The Science of Microbiology**

### **General information for beginning experiments in growing microbes and molds**

1. Material on which to grow microbes: Slices of potato, sweet potato, carrot, or home-made bread.
2. Dishes: Shallow dishes with covers such as glass coasters (make covers out of squares of window glass), baby food jars or clear plastic refrigerator dishes. Dishes must be clean and free of bacteria.
3. Sources of microbes—dirty hands, garbage can, a fly, hair, souring milk, stagnant water, decaying or molding fruit.

### **PROJECT NO. 1: *Determine Whether Microbes Grow Best Where It Is Dry or Moist***

#### **MATERIALS**

1. Two shallow glass dishes with covers
2. Potato
3. Source of microbe (decaying fruit)
4. Toothpicks or Q-tips

#### **PROCEDURE**

1. Dishes must be sterile. Wash dishes thoroughly and dry in oven.
2. Slice potato into thin slices (1/8 inch) that will fit flat in bottom of dish. Wash potato slices in clean water and place in sterile dishes.
3. Be sure hands are clean.
4. Place toothpicks in covered can and heat in oven for 20 minutes to kill bacteria.
5. Take sterile toothpick or swab stick—touch it to decaying fruit, then wipe bacteria on potato slices and cover the dishes.
6. Place one dish on radiator where it will dry out. Place second dish in dark place where it will not dry out.
7. Examine dishes each day for several days.

#### **RESULTS**

Microbes grow best in moist place.

### **PROJECT NO. 2: *Determine Whether Microbes Grow Best Where It is Warm or Cold***

#### **MATERIALS**

1. Two shallow dishes with covers
2. Potato
3. Source of microbes (decaying fruit, dirt from under fingernails)
4. Toothpicks

#### **PROCEDURE**

1. Sterilize dishes and toothpicks (see project No. 1).
2. Slice potato into thin slices (about 1/8-inch). Wash two potato slices in clean water and place in sterile dishes.
3. Take sterile toothpick and touch bacteria source. Wipe bacteria on potato slices and cover dishes.
4. Place one dish in refrigerator and other in warm dark place.
5. Examine dishes each day for several days.

#### **RESULTS**

Microbes grow best in a warm place.

### **PROJECT NO. 3: *Determine Whether Microbes Grow Better in Dark or in Light***

#### **MATERIAL**

Same as in Projects No. 1 and No. 2

#### **PROCEDURE**

Same as in Project No. 2 except in Procedure 4. Place one dish in bright sunlight and the other in a dark place.

#### **RESULTS**

Microbes grow best in a dark place.

**PROJECT NO. 4:** *Determine Whether Disinfectants Kill Microbes*

**MATERIALS**

1. Several dishes as in project No. 1
2. Types of household disinfectants

**PROCEDURE**

1. Prepare dishes as in project No. 1.
2. Place microbes on potato in all dishes.
3. Save one dish as a control (do not put disinfectant in this dish).
4. Cover potato slices with disks of paper towel that have been soaked in:
  - (a) Tincture of iodine
  - (b) Alcohol
  - (c) Lysol
  - (d) Mercurochrome
  - (e) Witch hazel.
5. Label all dishes and place in a warm dark room.
6. Examine dishes each day for several days.

**RESULTS**

Disinfectants slow or stop the growth of bacteria.

**PROJECT NO. 5:** *Show That We Have Microbes on Our Hands*

**MATERIALS**

1. Two small potatoes
2. Two baby food jars
3. Paring knife

**PROCEDURE**

1. Put jars and tops in boiling hot water to kill all bacteria. Allow to air dry.
2. Do not wash hands. Peel one potato, put it in jar and cover. (Label jar "unwashed hands.")
3. Wash hands, potato and knife with soap and water. Peel potato and place it in second jar. (Label "washed.")

**RESULTS**

Potato in jar labeled "washed" will show no mold growth. Potato in jar labeled "unwashed" will show mold growth.

## Meeting No. 9:

# The Science of Meteorology

### PROJECT NO 1: *Make a Hygrometer*

#### MATERIALS

1. Milk carton
2. Long hair
3. Paper clip
4. Thumbtack
5. Weight

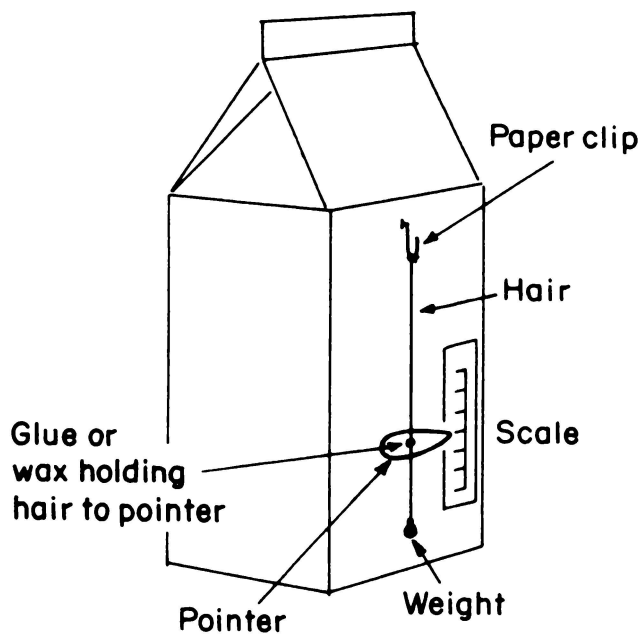

#### PROCEDURE

1. Make heavy paper pointer and attach to milk carton about 2 inches from bottom. Pointer must be free to move up and down.
2. Make scale and attach to milk carton at end of pointer.
3. Tie nut or weight on one end of hair. Tie other end of hair to paper clip.
4. Attach paper clip to milk carton with hair hanging over middle of pointer.

#### RESULTS

If it is relatively dry, the hair will become shorter and will become longer when there is more humidity.

### PROJECT NO. 2: *Make a Barometer*

#### MATERIALS

1. Hard plastic refrigerator dish with tight cover
2. Wooden base about 3 inches x 6 inches x 1 foot
3. Piece of stiff cardboard about 2 x 8 (scale)
4. Small cork
5. Broom straw 8 inches long or thin balsa strip about 8 inches long (pointer).

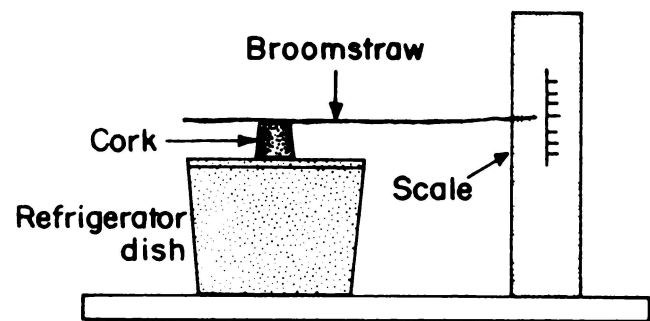

#### PROCEDURE

1. Glue cork in exact center of refrigerator dish cover.
2. Warm refrigerator dish in hot water. Place cover on dish and seal with wax.
3. Glue broom straw to cork.
4. Attach cardboard paper scale at end of base-board.

#### RESULTS

When air pressure decreases, the top of plastic dish pushes straw upward.

**PROJECT NO. 3: *Make a Water Weather Thermometer***

**MATERIAL**

1. Glass milk bottle

**PROCEDURE**

1. Color water with ink or fruit coloring.
2. Make hole in bottle cap to fit soda straw.
3. Place bottle cap with tube inserted on bottle.
4. Seal cap and tube to top of bottle with melted candle wax.
5. Add colored water (with medicine dropper) to bring liquid level about 3 inches above bottle top.
6. Make cardboard scale and attach to soda straw.

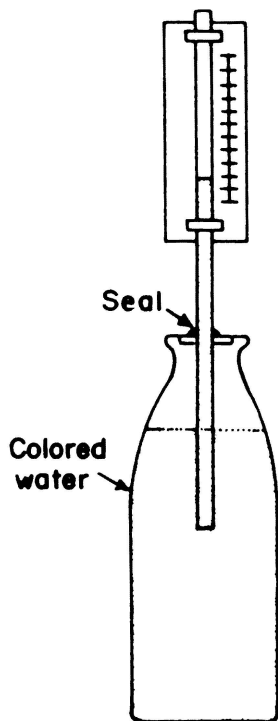

**RESULTS**

Liquid moves up and down soda straw as temperature of water changes.

**PROJECT NO. 4: *Make a Rain Gauge***

**MATERIAL**

1. Straight sided bottle about six inches high

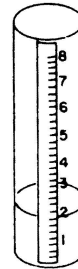

**PROCEDURE**

1. Paste strip of masking tape on side of bottle.
2. Mark (with waterproof ink) the masking tape in 1/8-inch spaces.
3. Set rain gauge in open spot where it will not easily be upset.
4. Check rain gauge after every shower. Record inches of rainfall and empty gauge.

**PROJECT NO. 5: *Make a Wind Vane***

**MATERIALS**

1. Piece of wood about one foot long, 1/2-inch thick and 3 inches wide
2. Mounting stick about 3/4 inch x 3/4 inch x 1-foot
3. Nail or screw for attaching arrow to mounting stick

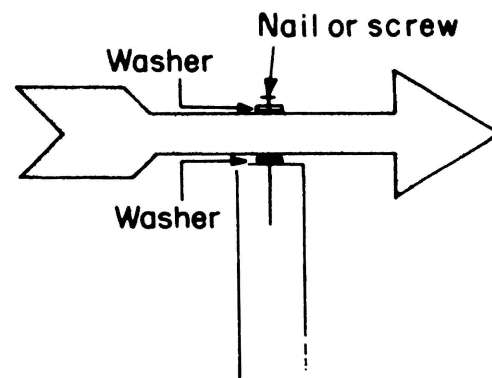

**PROCEDURE**

1. Cut out arrow.
2. Drill hole in exact center of arrow shaft.
3. Mount arrow on stick with screw or nail.
4. Attach to building or pole where it has access to wind from all directions.

## The Science of Meteorology . . .

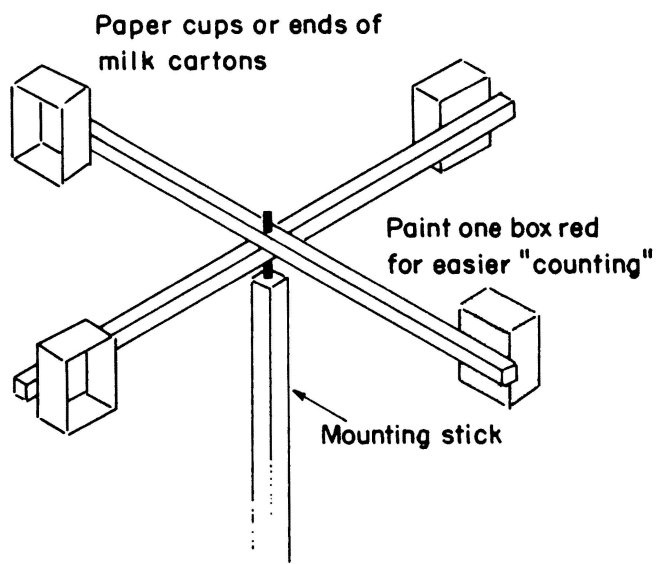

### PROJECT NO. 6: *Make a Wind Speed Indicator (Anemometer)*

#### MATERIALS

1. 2 pieces of light wood  $\frac{3}{4}$  x  $\frac{3}{4}$  x 12 inches
2. Bottoms from 4 paper milk cartons or 4 paper cups

#### PROCEDURE

1. Fit sticks together at right angles.
2. Attach cups to ends of sticks.
3. Drill hole at exact center of sticks and attach to mounting stick.
4. Mount outdoors in a place that has access to the wind in all directions.

#### RESULTS

You can get a rough idea of the wind speed by counting the turns made in 30 seconds and dividing by 3 or have someone drive you in their car and count the number of turns at various speeds.

## Meeting No. 10:

# The Science of Chemistry

## (Solids, Liquids and Gases)

### PROJECT NO. 1: *Change a Liquid Into a Solid*

#### MATERIALS

1. Two one-ounce squares of unsweetened chocolate
2.  $\frac{3}{4}$  cup of scalded milk
3. 2 cups of sugar
4. 1 teaspoon of light corn syrup
5. 2 tablespoons of butter
6. 1 teaspoon vanilla

#### PROCEDURE

1. Melt chocolate in milk, add sugar and corn syrup.
2. Cook slowly, stirring until sugar dissolves.
3. Cook gently to soft ball stage ( $234^{\circ}$ ), stirring frequently.
4. Remove from heat, add butter and cool to room temperature without stirring.
5. Add vanilla and beat vigorously until liquid becomes very thick.
6. Add 1 cup of chopped nuts.
7. Quickly spread in greased pan.

#### RESULTS

Chocolate fudge.

### PROJECT NO. 2: *Make a Magic Garden*

#### MATERIALS

1. Small fish bowl or clear glass jar that will hold about 1 quart
2. Coarse, clean sand
3. Sodium silicate (water glass) can be purchased at any drug store
4. Crystals of  $\frac{1}{8}$ -inch copper sulfate, ferrous sulfate, zinc sulfate, cobalt chloride and manganese

chloride (these can be purchased at any chemical supply house)

#### PROCEDURE

1. Place about  $\frac{1}{4}$  inch of sand on bottom of glass jar.
2. Fill jar with sodium silicate solution diluted with equal amount of water.
3. Drop salts to bottom of jar one by one so that they are distributed on sand.
4. Wash your hands after you have finished.

#### RESULTS

Within an hour or two the garden will be completely grown and a forest of vari-colored growth will emerge. If you have difficulty obtaining some of the above materials, try this simple magic garden with coal.

#### OTHER MATERIALS

1. 6 tablespoons of salt
2. 6 tablespoons of blueing or food coloring
3. 6 tablespoons of water
4. 1 tablespoon of ammonia

#### PROCEDURE

Pour your solution (it should be cloudy) over a small piece of coal about the size of your fist. The coal should be in a small flat dish at least 2 inches deep.

#### RESULTS

Watch your garden grow.

### PROJECT NO. 3: *Embed Insects, Coins, Flowers, etc. in Plastic*

SEE: Project No. 2, page 3.

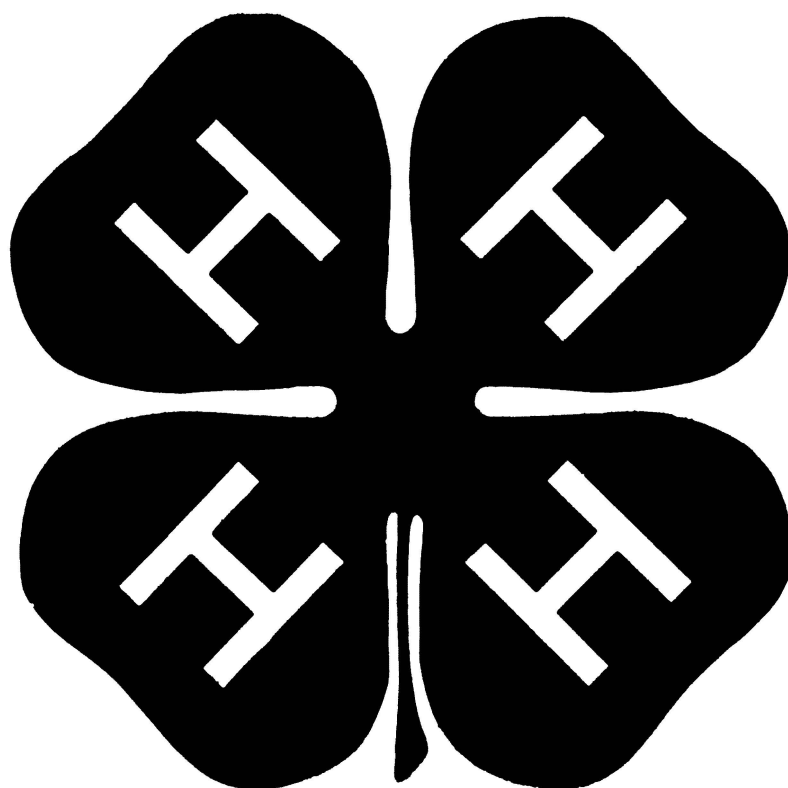

## REFERENCES

1. *Golden Book of Chemistry Experiments*  
Golden Press Inc.  
Rockefeller Center  
New York 20, New York
2. *700 Science Experiments for Everyone*  
Doubleday and Company, Inc.  
Garden City, New York
3. *Sourcebook for Elementary Science*  
Harcourt, Brace and World, Inc.  
New York, New York
4. *Sourcebook for Physical Sciences*  
Harcourt, Brace and World, Inc.  
New York, New York
5. *Sourcebook for Biological Sciences*  
Harcourt, Brace and Company  
New York, New York
6. *The Hidden You*  
Prentice-Hall, Inc.  
Englewood Cliffs  
New Jersey
7. *Puzzle Patterns*  
William Morrow and Company  
425 Park Avenue South  
New York 16, New York
8. *Stars*  
Golden Press, Inc.  
Rockefeller Center  
New York 20, New York
9. *Thunder and Lightning*  
Doubleday and Company, Inc.  
Garden City, New Jersey
10. *The Big Dig*  
The Dial Press  
New York, New York

This bulletin was written by:

JAMES CULVER, 4-H TV Club Producer  
GERALD RITCHEY, Science Advisor

Reprinted from material published by the Cooperative  
Extension Service of Michigan State University.