

BUILDING INTERACTIVE MODELING FOR CONSTRUCTION EDUCATION IN VIRTUAL WORLDS

SUBMITTED: June 2010

REVISED: September 2010

PUBLISHED: February 2011 at <http://www.itcon.org/2010/13>

EDITOR: Turk Z.

Kihong Ku

Department of Building Construction, School of Construction, Virginia Tech, USA
kku@vt.edu

Pushkar S. Mahabaleshwarkar

Master of Building Construction graduate, Virginia Tech, USA
pushkarm@vt.edu

SUMMARY: *The number of design and construction professionals who are using Building Information Modeling (BIM) is rapidly growing and simultaneously the architecture, engineering, and construction (AEC) community is faced with the challenge of remote collaboration as offshore outsourcing continues to grow. While BIM facilitates information sharing between AEC professionals via purpose-built three-dimensional (3D), 4D design, analysis, evaluation, and documentation models, the communication of such 3D data-rich models is often fragmented and typically limits real-time communication and interaction of users who may be geographically dispersed and/or lack the modeling and analyses skills to interact with these models. AEC education needs to expose students to these emerging practice changes while finding new ways to more effectively address the fundamentals of design and construction. Virtual worlds – in this research the Second Life platform – have the potential to address the communication issues and effectively complement traditional teaching approaches and furthermore integrate with BIM to enhance construction education. Nevertheless, despite the potential benefits of virtual worlds, various obstacles exist. This paper presents the concept of Building interactive Modeling (BiM) which complements the capabilities of BIM with social interaction to enhance collaborative information and knowledge sharing. Role-playing scenarios developed in Second Life demonstrate specific opportunities of BiM.*

KEYWORDS: *Building interactive Modeling, Virtual, Remote Collaboration, Role playing, Scenario, Building Information Modeling*

REFERENCE: *Kihong Ku, Pushkar S. Mahabaleshwarkar(2011) Building interactive modeling for construction education in virtual worlds, Journal of Information Technology in Construction (ITcon), Vol. 16, pg. 189-208, <http://www.itcon.org/2011/13>*

COPYRIGHT: © 2011 The authors. This is an open access article distributed under the terms of the Creative Commons Attribution 3.0 unported (<http://creativecommons.org/licenses/by/3.0/>), which permits unrestricted use, distribution, and reproduction in any medium, provided the original work is properly cited.



1. RESEARCH GOAL AND METHODOLOGY

The focus of this paper is the promise of virtual worlds as emerging environments for construction education that complement traditional classroom based teaching approaches and supplement the modeling and simulation functions of BIM (building information modeling) with social interaction and information exchange capabilities. The authors define the vision and concept of Building interactive Modeling (BiM) which suggests the combination of virtual worlds and BIM as a platform and environment for virtual collaboration and learning. Second Life is discussed as an environment for specific role-playing scenarios of design and construction tasks and mirroring (Mitchell, 2008) of the physical environment through sensors (e.g., thermal sensor, light sensors, wind sensors, etc.) for operation and maintenance of buildings, in light of various examples developed by the authors.

The primary research sources for this paper are example scenarios developed in Second Life by the authors for construction process simulation, construction safety training, design reviews and building system control and monitoring. The research required scenario development based on the authors' experience in construction management and education, programming (scripting within Second Life), and virtual collaborations in a cross-university course based on various BIM tools and models.

2. BACKGROUND

Currently, the architecture, engineering and construction (AEC) industry is facing enormous technological and institutional transformations with their resultant difficulties and challenges. The industry is embracing new modes of information sharing and adopting emerging and fast growing concepts such as building information modeling (BIM), sustainability, virtual collaboration and related technologies. Almost fifty percent of the AEC industry is now using BIM and twenty percent of non-users are planning to adopt it within two years (McGrawHill, 2009). In addition, the phenomenon of off-shoring, outsourcing architectural and engineering services to companies in southeast Asia, South America, or Eastern Europe, is increasing (Nayak and Taylor, 2009; Del Villar and Pollalis, 2007). Outsourcing impacts the team dynamics as effective remote collaboration in these practices is essential to successfully produce construction drawings and relevant digital deliverables as a result of this interaction. Lack of adequately BIM trained personnel is a significant constraint hindering the use and adoption of the technology in the industry (Sacks and Barak, 2009). The ASCE Policy 465 "Body of Knowledge" (BOK and BOK2) acknowledges that engineers need to deal with globalization and working in integrated international environments and furthermore raises the issues involved with outsourcing and doing business remotely using the internet and other computer tools. Traditional teaching or training courses do not effectively bridge this gap between training/academia and practice.

Virtual Learning Environments effectively complement traditional education (Koskela et al., 2005; Sawhney and Mund, 1998) extending beyond the physical reach of classrooms over the internet. Building on the advancements of information, communication, and simulation technologies, Virtual Reality (VR) techniques have been extensively utilized for training high-risk occupations such as pilots and nuclear power plant operators. The mining industry has begun to adopt VR for task-based training (Lucas and Thabet, 2007; Kizil and Joy, 2001). However, VR approaches that utilize role-playing for educational purposes in construction have been limited. While the Building Management Simulation Center in Leeuwarden, Netherlands, and the Advanced Construction Technologies Simulation Center (ACT) in Coventry, UK, offer innovative experiential learning through simulated role-playing scenarios that integrate physical jobsite environments (e.g., site huts) and virtual reality models projected onto large parabolic projection screens (Stothers, 2007), these programs have been constrained to the physical location of the centers. To benefit a larger audience of construction students who are primarily studying in rather traditional classroom settings, research should investigate the possibilities of virtual reality simulation environments that could be delivered over the internet. The introduction of virtual worlds such as Second Life to design (Nederveen, 2007) and construction education (Ku and Gaikwad, 2009) has the potential to bridge the gap between learning about a subject and 'learning by doing'. In the context of these needs, this paper discusses the possibilities and limitations of 'Building interactive Modeling' a novel concept that was envisioned using examples in the Second Life environment for construction education.

3. DEFINING BUILDING INTERACTIVE MODELING

The authors propose the concept of Building interactive Modeling (BiM) which is a collaborative communication framework that augments the concepts of Building Information Modeling to enhance user input and facilitate user interaction with the model and other users. BiM utilizes interactive and immersive functionalities of virtual world environments and allows multiple stakeholders to collaboratively model, visualize, review, and update 3D digital models to share the various perspectives and knowledge and information of participants during the lifecycle of buildings. The Building interactive Modeling framework in this paper concentrates on construction education and is illustrated through scenarios in a virtual worlds environment. The enabling technologies include virtual worlds, building information modeling, and the concepts are based on the notion of collaboration in architecture, engineering, and construction.

3.1 Virtual Reality, Virtual Construction and Virtual Worlds

Virtual Reality (VR) technology has been used in 3D graphics, video games, 3D scientific visualization, architectural design, and medical research and education (Messner and Horman, 2003). Messner and Horman further elaborate on the use of VR for visualization of project designs, visualization of construction plans and schedules, design and analysis of construction equipment, and communication and training of project teams. In addition, they categorize VR technology into desktop VR and Immersive VR. The primary application of VR in construction is to simulate real world properties through 3D visualization and to allow interactive navigation to examine the construction process. Thus, previous VR research in construction has been intimately related to virtual construction research which has concentrated on 3D and 4D CAD modeling that are being applied to construction visualization as a project management tool to assist decision-making of the construction planning process (Kamat and Martinez, 2000; Fischer et al., 2003). These methods link 3D building models with construction activity sequences to visualize activities of a schedule. 4D virtual construction models have also been explored as self-directed tools for web-based open learning (Haque and Shah, 2007). However, a shortcoming of 4D CAD approaches has been the inability to visualize the processes of material movement and installation of construction components, which are omitted and simply represented as products within its final position temporarily fading in and out (Rowlinson and Hadikusumo, 2003). To overcome this issue, Huang et al. (2007) have developed a virtual prototyping system which integrates construction processes such as material storage, staging, and erection. Acknowledging the emphasis of research and development on 4D visualization for construction planning, and furthermore, the recent movement towards Building Information Modeling which intends to integrate all relevant information from design to construction, VR for construction education should incorporate and enhance process components and interaction with temporary structures. The value of simulation based construction learning tools is significant (Sawhney and Mund, 1998), and Stothers (2007) describes virtual reality simulator techniques that emulate the complexity of real work environments under work-like pressure to encourage dynamic and critical thinking based on carefully structured scenarios that can be replicated. Therefore, research should examine the potential of VR not only to apply interactive role-playing tools to 4D product models but also to integrate process visualizations of temporary works and construction equipment to enhance real-world context for deeper learning.

Taking advantage of virtual worlds' ability to complement traditional learning environments, many educational institutions have implemented online virtual training courses to engage students with role playing experiences. In fall 2007, Regent University conducted an online counseling skills class using Second Life to provide key role-playing experiences to distance education students. The facility was designed considering the specific needs of confidentiality and privacy required for the instructors and students of Human Services Counseling (Walker and Rockinson-Szapkiw, 2009). Similarly, Harvard University began offering a law course in Second Life from fall of 2006 (Foster, 2006).

Considering the design and construction industry, the primary application of VR is to simulate real world scenarios through 3D visualization allowing interactive navigation to examine the construction process. Previous research in the exploration of virtual worlds has demonstrated that they could provide an excellent platform for an open source collaborative design practice. The project 'Wikitecture' experimented with design collaboration and developed procedures and protocols that are necessary to practice a more open and distributed approach to architectural design (Chase et al., 2008). Maher et al. (2005) presented the 'Design World'

environment which enables collaboration between designers from different disciplines who may be in different physical locations.

A study on visualization technologies (VT) for the integration of building end-user perspectives, Alejandro Carvajal (2005) argued that current VT applications in design and construction do not address building end users' (BEU) needs. The process of communicating and transforming end-user requirements into project design has not been adequate and explicit (Egan, 1998; Latham, 1994). Traditionally, sketches and drawings are being used to translate client needs into design specifications making it difficult for end users to comment due to their inability to properly read and understand two-dimensional drawings (Barrett and Stanley, 1999). Carvajal (2005) further argued that building end-users are a source of experience, expertise, and new ideas which can be "accessed" by means of visualization technologies and demonstrated that when dealing with people who have not developed their spatial skills, or do not have an architectural or engineering background, visualization technology can effectively assist to identify end users' needs.

3.2 Building interactive Modeling (BiM)

An emerging area of research of virtual worlds applications is the use of serious gaming in the AEC industry. Virtual worlds have the potential to engage and support non-specialist building end users, novice students who are learning about the building design and construction process, and also facilitate the interaction among multidisciplinary design team members who are geographically dispersed. For example, virtual worlds can involve, building end user to reach collective design decisions and control the way in which decisions are made, monitor results, and improve productivity of meetings. According to Maher and Merrick (2005), a networked and multi-user virtual environment can be used as a tool to support a broad range of activities including communication, collaboration and education. This research proposes the concept of Building interactive Modeling (BiM) which facilitates real time communication and interaction to allow enhanced collaborative visualization, inspection, interaction, and manipulation of complex 3D models to break the barriers of knowledge and information flow from client briefing to operation and maintenance phases. Building interactive Modeling (BiM) combines BIM and virtual worlds and facilitates interactive simulation of tasks including real time collaboration for construction planning, design reviews, interactive training, and facilities management performed by multiple project players who are not always collocated and technically proficient to interact with digital models produced in Building Information Modeling software environments (Fig. 1).

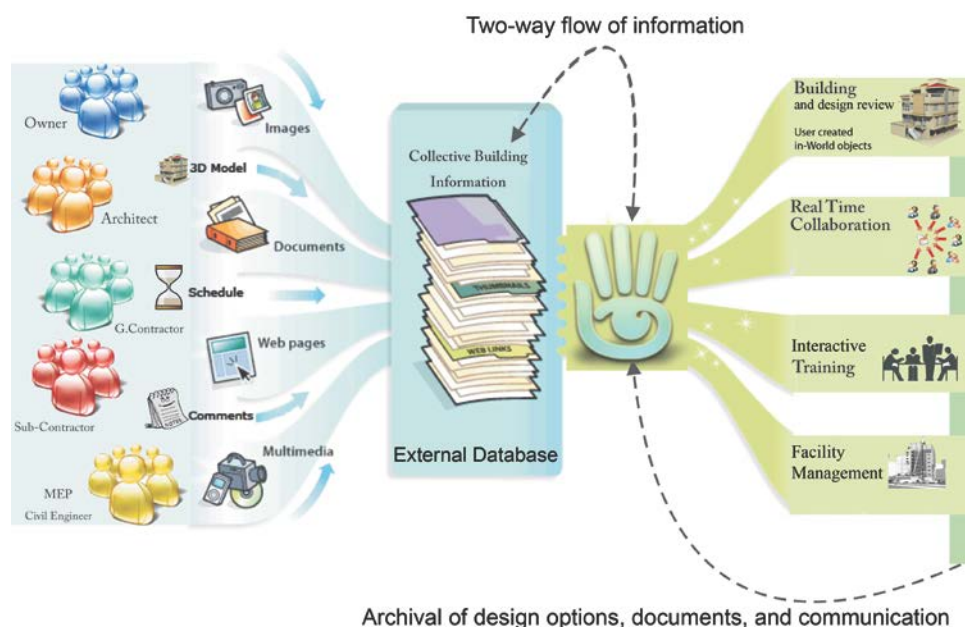

FIG. 1: Building interactive Modeling concept to improve AEC collaboration

In this paper we define Building interactive Modeling (BiM) as an interface that mediates three-way synchronous and asynchronous immersive or semi-immersive multi-user or human-computer interaction. Figure 2 illustrates the three-way communication of BiM that is facilitated in virtual environments. BiM allows users with minimal software skills to participate in a collective decision making process through role-playing scenarios that involve interaction with building systems and/or construction equipment and other project participants or players during project programming, design, construction, and O&M phases to access, manage, simulate, analyze, and update project data.

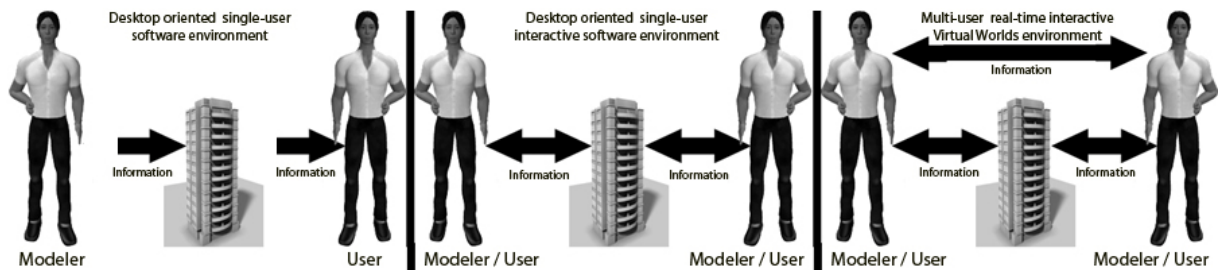

FIG. 2: Comparison between single, two-way and three-way interactive environments

For the widespread use of VR in the construction industry it is important that 2D and 3D representations become the primary interface for interactivity (Issa, 2000). The above mentioned Building interactive Model concept would provide a networked multiuser environment that accommodates 3D modeling and simulates physical interaction in virtual spaces with an enhanced ability of collaborative visualization, inspection, interaction, and manipulation of complex building models. To explore a proof-of-concept of the building interactive modeling framework, the authors have investigated Second Life (www.secondlife.com) a commercial virtual worlds platform. The examination of the tool requirements for an end-user interface included development of various scenarios and interface components for the various lifecycle phases of programming, design, construction, and operations and maintenance (Fig. 3). The scenarios included architectural design options review via geometry filters, building systems library, construction and safety planning via 4D visualization and safety training scenarios, and building system control and monitoring via physical-virtual systems integration.

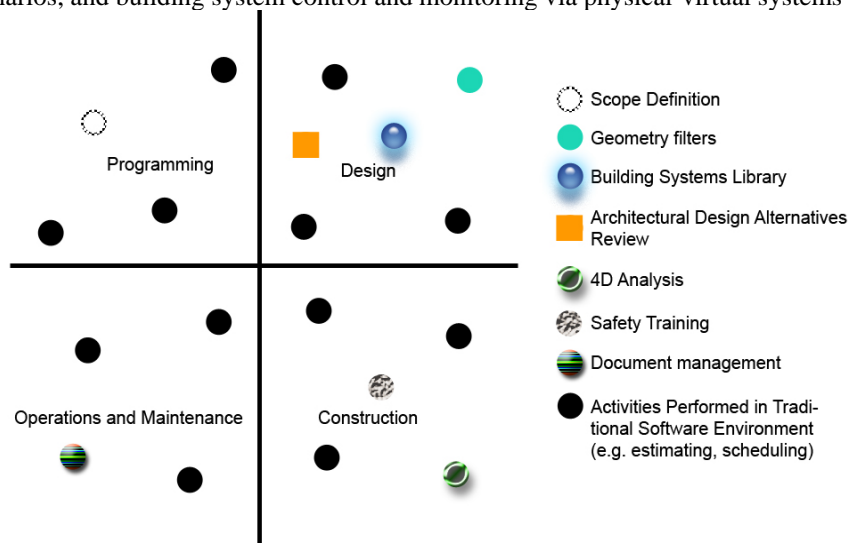

FIG. 3: Virtual worlds applications for BiM

Table 1 summarizes the areas of Building interactive Modeling for construction education that were explored in this study and categorizes the key components and applications devised in the Virtual Worlds environments. The BiM areas were explored through a number of scenarios implemented in Second Life and are described in subsequent sections of this paper as indicated in Table 1.

TABLE 1: Overview of BiM areas and its virtual worlds components and specific scenarios

BiM Areas	Virtual Worlds Components	Scenarios
Programming & design review	Scope definition Geometry filters Building systems library for design alternatives	Students can learn real time collaboration of how building end users interact with the building model and design teams to evaluate design options. Dispersed users can navigate the building and chose different materials, modify building components, attach review notes, etc. (Section 4.3)
Construction planning	Construction equipment operation Safety training 4D visualization	Students can learn and explore construction planning by interactively operating equipment to move and install material into its final position in the building (Section 4.1) Students can learn about the various safety aspects of construction equipment and operations via interactive tutorial sessions, interactive quizzes, and hands-on role-playing scenarios (Section 4.1) Dispersed teams of students can visualize and review 4D sequencing of construction operations in immersive settings (Section 4.2)
Facility management	Building systems control	Building environmental systems composed of various sensors, actuators, can be integrated with virtual worlds models to control and monitor physical building systems. (Section 4.4)

4. BIM EXPLORATIONS IN SECOND LIFE

Second Life, created by Linden Lab, is a virtual world which is used for serious gaming (i.e., games for simulation of management training, collaborative decision-making, and for education (Nederveen, 2007)). This environment is a distributed, virtual space where people are represented as avatars, created and customized by themselves. People represented as avatars can walk, fly, chat, and interact with other people, objects or computer-controlled agents in place like contexts. Avatars can walk around and build with a building toolset and the primitive objects, “prims”, which are single-part objects or multi-part objects that are combined of prims, or “sculpties” which are more complex primitives whose shape is determined by an array of x, y, z coordinates stored as RGB values in an image file. Unlike video games, Second Life is used by health-care providers, companies, academics, and the military, to learn and work together, and to trade in real world virtual items, or to run medical triage simulation (Economist, 2007).

Some examples of training applications in Second Life include virtual cancer labs for training doctors by European universities, consortiums of corporate training entities of Wal-Mart stores, American Express, Intel, and more than 200 other companies who are experimenting with alternative ways to foster more collaborative learning environments. As government entities, the Swedish embassy is one of the first organizations that have established a virtual presence in Second Life as an information portal for Sweden (sweden.se). Nederveen (2007) discusses the possibilities of Second Life for collaborative architectural design focusing on the many virtual complex constructions that have already been collaboratively created within Second Life. In a similar context, Studio Wikitecture’s (<http://studiowikitecture.wordpress.com/>) “Open Architecture” approach demonstrates an interesting collective design experiment for architecture and city planning.

To take advantage of Second Life’s functionality for interactive communication and visualization, the authors conducted an investigation of Second Life on incorporating role-playing scenarios for construction process learning, 4D visualization, safety training, design reviews, and real-time integration of physical sensors for building monitoring. The proposed database integration between external BIM repositories and the Second Life environment (Fig. 1) was not implemented in this research because it requires server level integration that has to

be supported by Linden Lab. However, utilizing the scripting interface of the Second Life browser, a number of educational role-playing scenarios were developed to illustrate the potential of Second Life for BiM. Figure 4 shows the overall framework of the scenario workflow and the relevant players for each scenario as discussed in the following subsections.

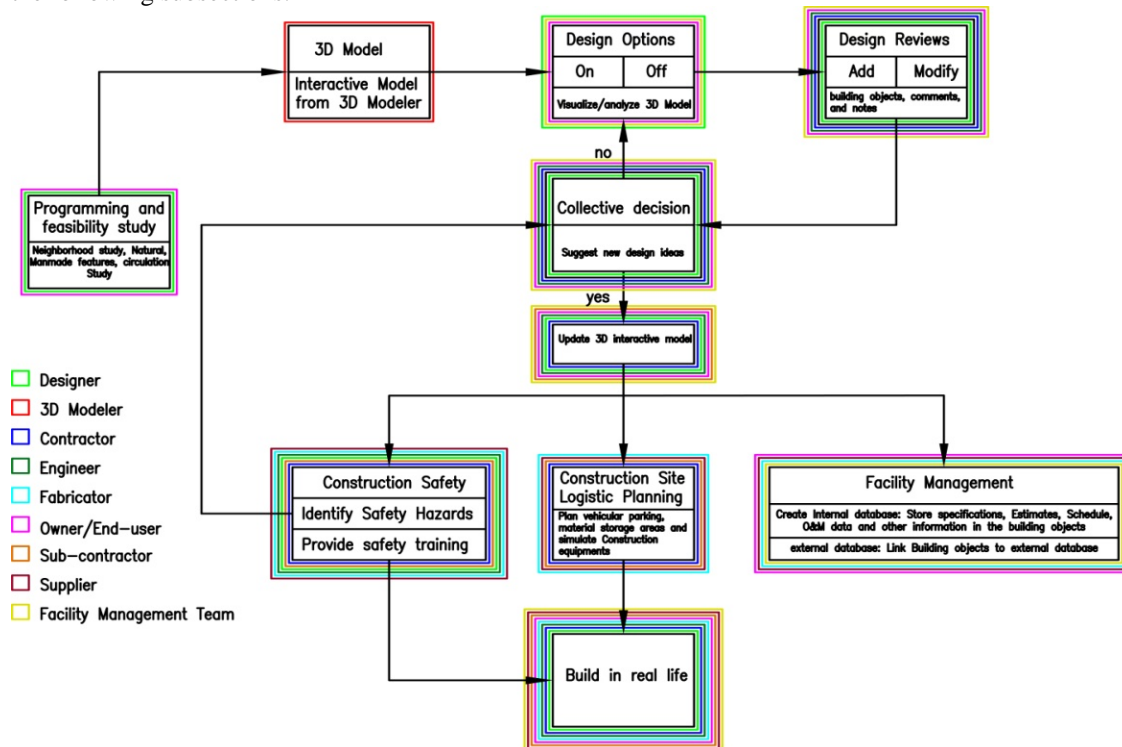

FIG. 4: Mapping of the BiM scenarios

4.1 Construction planning and safety training

A virtual project of a real-life construction project was developed to understand the modeling process of building models. A virtual model of the Bishop-Favaro Hall, a recently completed Virginia Tech building for the School of Construction (Fig. 5) was selected because detailed project documentation (e.g., CAD drawings, shop drawings, etc.) were available and information (project photos, project schedule, project participant interviews, etc.) of the construction process had been collected during and post construction.

Modeling Workflow for Second Life

The first step was to acquire an empty piece of land (island) in Second Life which was located on the “Panaki Cove” on the Second Life grid to create the virtual model of the existing building (Fig. 5). Based on the construction drawings and shop drawings, the building model was broken into steelwork components, concrete floors, architectural precast panels, and windows. Because the modeling process in Second Life is time-consuming in comparison to specialized modeling software such as Revit or AutoCAD, the authors initially created a Revit model. However, the file import process into Second Life caused difficulties with the Revit CAD file format. Therefore, the authors searched for an alternative modeling tool that was supported by Second Life. The AC3D software interface is similar to standard 3D modeling software and thus allows rather efficient modeling compared to Second Life modeling and produces an acceptable file format to export to Second Life. Third-party plug-in software for CAD software (e.g., AutoCAD, Maya, 3D Max) import has been under development by various entities such as the Delft University of Technology. Figure 6 demonstrates the model file conversion process from AC3D to Second Life. The objective of modeling the building was to understand how individual components could be broken into basic building blocks and components for assembly simulation within Second Life. The modeling exercise illustrated that individual components could be moved, installed and joined, to simulate material storage, staging, erection, and assembly processes.



FIG. 5: Bishop-Favrao Hall photo (top), Second Life model (bottom left) and project site (bottom right)

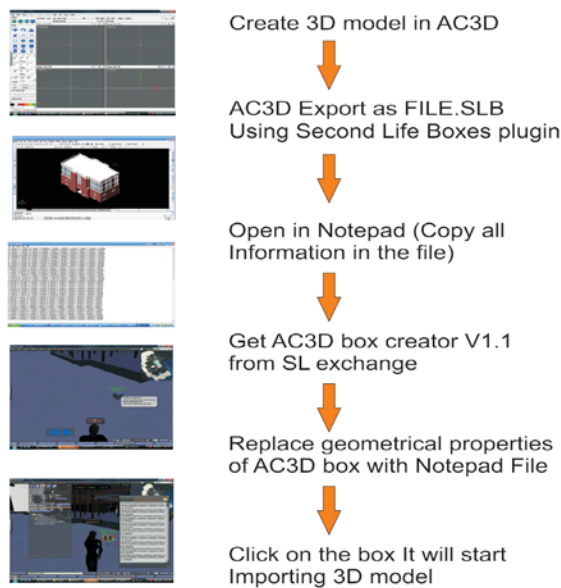

FIG. 6: File conversion process

Temporary works - Scaffold safety training

As temporary works are a critical element of the overall construction planning process (Huang et al., 2007), the case study included an erection scenario of scaffolding. Temporary works can be modeled or also traded within Second Life with other people who have already modeled such structures. Rather than modeling a scaffold from scratch, the case study purchased an existing model within Second Life from a vendor (GyroTech Construction Vehicle). Considering the significance of construction falls, involving scaffolding failures, a simple scenario was

created for safety training purposes. The first step was to categorize scaffolding hazards into component problems, connection problems, and miscellaneous problems. Component problems are related to single components such as a damaged bracket, a missing plank, or a missing support, to the guardrail, or a missing top rail, or mid-rail. Connection problems are related to connection defects in the scaffold. Miscellaneous problems are concerned with excessive spacing between posts, insufficient overlap between planks or overloading planks with excessive construction load.

The training scenario in Second Life was based on two major tasks, (1) the erection of the scaffolding platform, and (2) the inspection of an existing platform. In the erection scenario (Fig. 7), trainees participated by installing the platform components through a proper installation sequence and making sure that the components are appropriately positioned and connected. Erection instructions are provided within Second Life to trainees before the exercise. In the inspection scenario, the scaffolding components are already assembled and include problems and defects that are strategically planned, to be identified and corrected by the trainee (Figs. 8, 9).

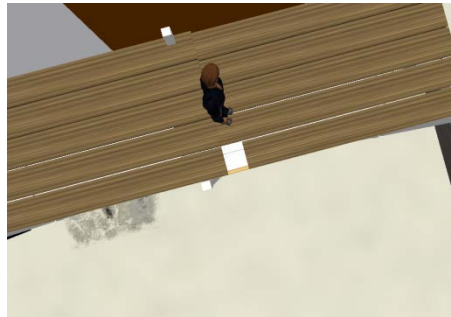

FIG. 7: Scaffold training – Erecting scaffold



FIG. 8: Scaffold training- Dislocated component and missing safety pin (left image)

FIG. 9: Scaffold training-Corrective action by trainee (right image)

Construction equipment – Tower Crane operation training

Cranes are a central component of many construction operations and are associated with a large fraction of construction deaths; in fact, estimates suggest that cranes are involved in up to one-third of all construction and maintenance fatalities (Kang and Miranda, 2006). Riggers and signalmen are a critical part of crane operations, and they need to receive training similar to that provided to operators. Second Life simulations can be used for training and studying collision-free and optimal-operational path for erecting structural elements, consequently reducing schedule delays and allowing safe construction. Methods to coordinate multiple cranes in a construction site can also be evaluated.

The creation of construction equipment such as cranes requires additional scripting to be added to the geometric model. For example, scripting is utilized to enable rotational motion of the jib around the base, horizontal movement of the roller along the jib, and vertical movement of the hook by the roller. Scripting is also required to enable the rigger to attach and detach load material from the hook.

For the case study, an existing crane was purchased to study the possibilities and limitations of crane control (Figs. 10, 11). Potential scenarios can address control issues of identifying the geometrical information from given buildings and cranes, searching for the safest and most-efficient paths to erect components.



FIG. 10: Crane training (left: bird's eye view of crane location on the site; right: ground level view of crane)

Communication is an integral activity for tower crane operation. Voice function in Second Life can emulate radio or other voice communication which is critical for tower cranes or mobile cranes where the operator is unable to see the load and therefore forced to rely on riggers and signalmen. In addition to voice communication systems, hand signals can be simulated within Second Life training scenarios as well. An illustration of a set of one- and two-handed signals of ANSI/ASME B30.x standards can be easily incorporated into the training scenario.

Training simulation center

A training center was developed nearby the virtual building (Figs. 12, 13). This facility was devised to provide safety instructions and the relevant training information for trainees before entering actual role-playing sessions. Displays provided in the facility can be linked to latest information available on the web, as well as training videos of detailed installation procedures (e.g., steel erection). Miniature models are exhibited within this virtual center to assist trainees' understanding of heavy equipment (Fig. 12). Instructors can also organize virtual seminars facilitated by chat and voice communication functions that can be used with or between trainees to interact with each other, complementing traditional classroom based lectures learning.



FIG. 11: Crane training- operator cabin



FIG. 12: Training center- Crane model



FIG. 13: Virtual training center in Second Life



Building on the first iteration, the second iteration incorporated safety standards and regulations using ‘local chat’, ‘dialog box’, and voice communication where each safety related object was given an information attribute to convey safety specific procedures in an interactive way. Interactive quizzes were scripted to verify the trainee’s ability of recognizing potential safety hazards (Fig. 14). ‘Red spheres’ were used to convey the information contained in the objects or building components. These spheres were useful to catch trainees’ attention. The scripts developed for this scenario generate:

- Animated objects
- Temporary change in object’s physical state
- Display information, standards, and regulations in text/audio format.

The following script is a schematic example of a prompt developed to communicate to an avatar OSHA Regulations (Standards – 29 CFR) Specific Excavation Requirements. - 1926.651.

default

```
{
  touch_start(integer total_number) {
    llSay(0,"Walkways shall be provided where employees or
    equipment are required or permitted to cross over excavations.
    Guardrails which comply with 1926.502(b) shall be provided where
    walkways are 6 feet (1.8 m) or more above lower levels.";
  }
}
```

Places which can present potential safety hazards such as falls were animated to react to trainee’s actions. To produce the effect of falls hazards related to unsafe lumber scaffolding, combinations of LSL (Linden Scripting Language) scripts and 3D objects that are broken into number of pieces were developed. These objects temporarily change in the 3D model environment. The safety training scenario flowchart and scripting flowchart for an animated scaffolding platform is illustrated in Figure 15 (‘rezzing’ refers to creating or making an object appear in a land on Second Life).



FIG. 14: Safety training scenarios in Second Life

4.2 Construction Sequencing Visualization

Traditional 4D visualization software are generally hosted locally on computers thus make it difficult to use for real time collaboration between dispersed parties, although recent model servers (e.g., Horizontal Glue is a web-based model server that allows real-time collaboration between dispersed parties and will be explained in this paper). To assess Second Life’s potential for distributed information sharing of construction sequencing the authors developed an LSL script that enabled to share a sequenced visualization of the construction of the building.

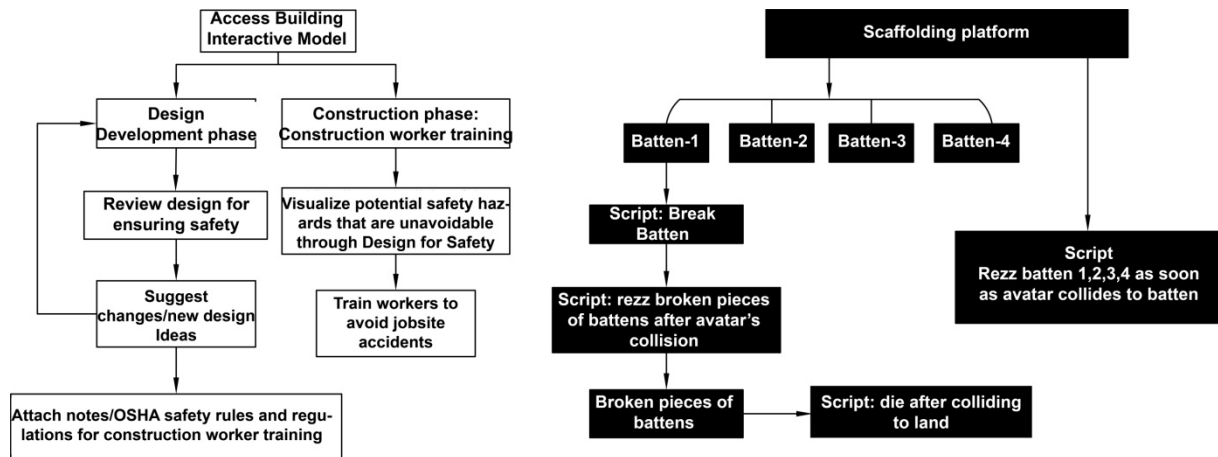

FIG. 15: Safety training scenario sequence and scripted object scripting map

To visualize the sequencing of construction components a script was developed to assign color codes and a time delay between individual components to display activity progress on a timeline. The script changed the visibility of the assigned building component and displayed the relevant activity start and end date and changed the building component color from red to green to graphically display which activities are in progress or already completed (Fig. 16).

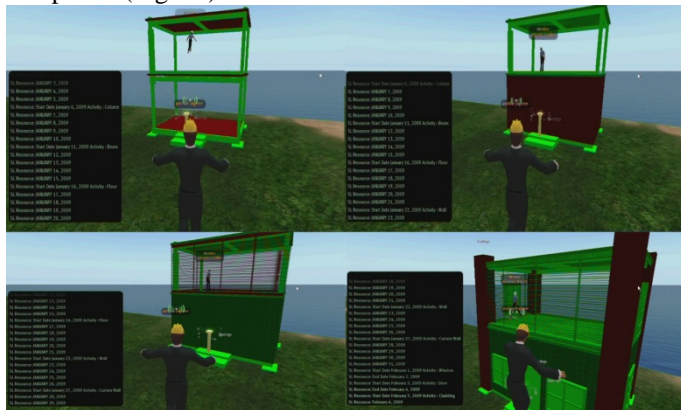

FIG. 16: 4D visualization in Second Life

The 4D analysis scenario allowed selection of various sequencing alternatives of a 3D model and viewer based viewpoint selection and navigation control. This scenario can be further developed to carry out clash detection between various building components. However, a major shortcoming of this visualization is that the script needs to manually include activity durations per a time delay that has to be scaled and calculated. The related assignment of visibility of the building components makes 4D visualization within Second Life a tedious task. It would be necessary to develop direct links to external scheduling software to make this process more user friendly.

4.3 Architectural Design Option Review

As construction projects are becoming more and more complex and require sophisticated design and engineering solutions, it is important to identify the best alternative if not the optimal solution (Carvajal, 2005). End-users and facilities management team can provide a valuable input during design evaluation proposal. Carvajal (2005) argues that end users have a developed experience and expertise of particular building spaces and systems with their continuous interaction and this expertise can be “accessed” by means of visualization technologies.

According to the CIC Design Quality Indicator Online (<http://www.dqi.org.uk/dqi/Common/DQIOnline.pdf>), the traditional design process involves the end user as a *guinea pig* who frequently ends up as an unhappy customer and remains unaware whether the building really meets the needs until it is occupied. Many studies have experimented with the use of computer graphics to improve visual/spatial skills to avoid such results (Miller and Bertoline, 1991). According to Treichler (1992) visualization improves spatial understanding and people learn up to 83% of the new information through sight.

One aspect of the Building interactive Modeling concept is to incorporate end users’ experience and expertise in building design through interactive visualization to allow their input of new design ideas, and access, update, approval of project early in the design process (Figs.17, 18). The developed a scenario focused on providing the following aspects to support interactive and collective decision making by the end users:

- Walk through the proposed building and attach notes/photos to approve design and/or suggest new design ideas;
- Modify building parts;
- Discover and solve design problems;
- Apply texture, materials, and architectural and design patterns.

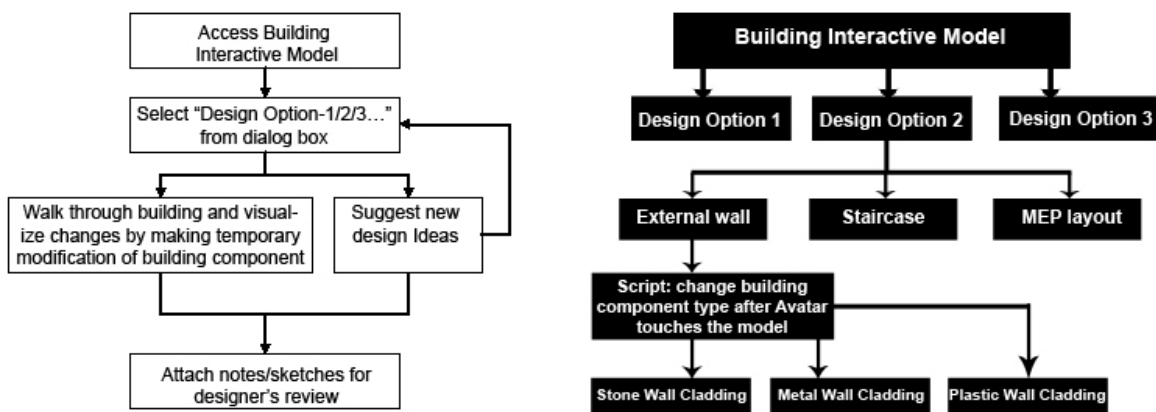

FIG. 17: Interactive design review scenario sequence and sculpted object scripting map

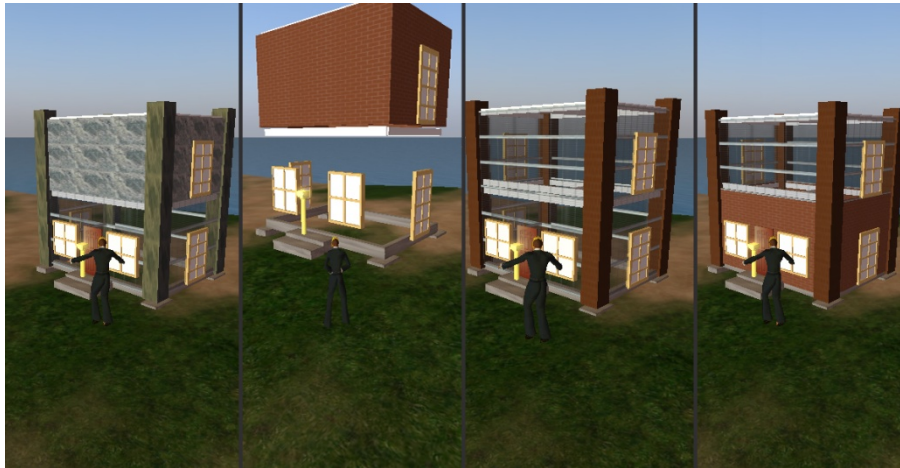
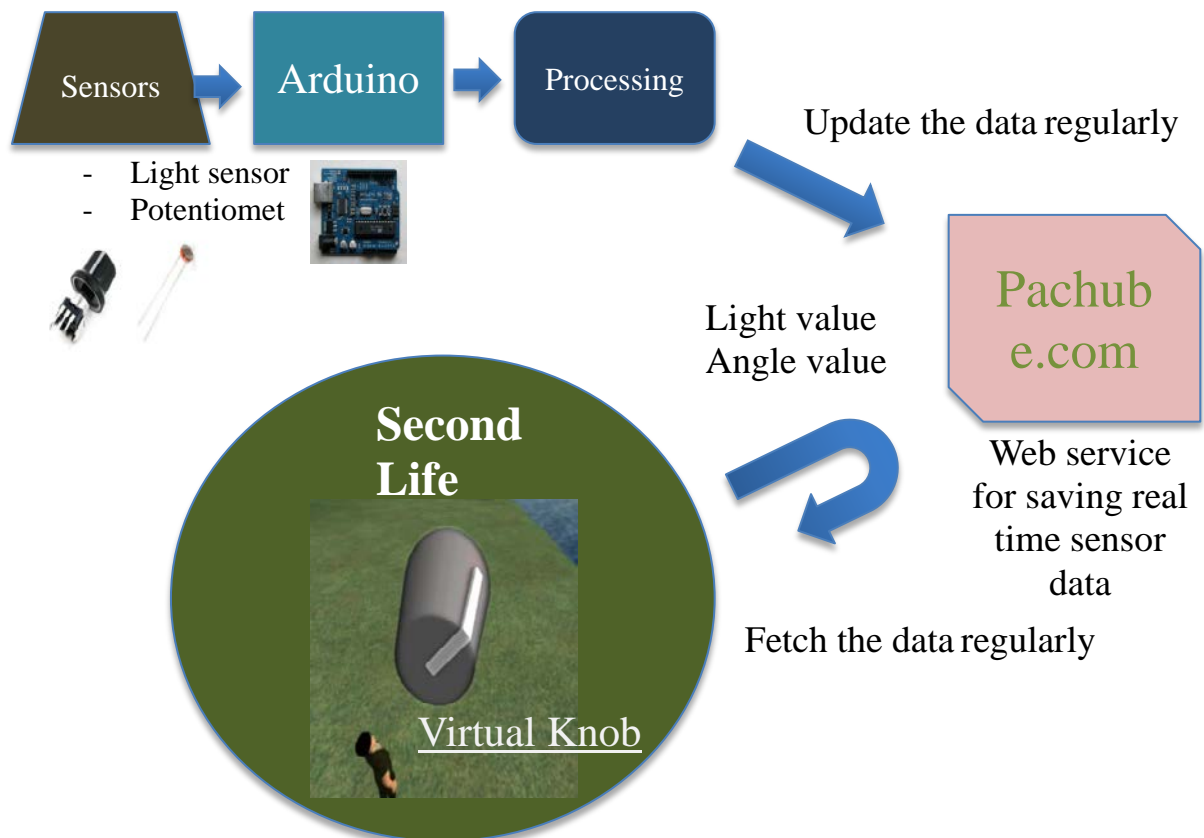

FIG. 18: Design review example

4.4 Integrating Physical Sensors and Actuators for Responsive Environments

Virtual environments also suggest direct links to the physical world through sensors and actuators which can interpret and control the physical environment. The emerging paradigm of intelligent environments (Addington and Schodek, 2005), interactive architecture (Fox and Kemp, 2009), architectural robotics (Green and Gross, 2009), responsive architecture (Chiu, 2009), focus on environments that not only facilitate interaction between people, but also actively reconfigure themselves in response to human and environmental stimuli. The fusion of computation and physical tangible sensors and actuators transform the control of building lighting, acoustics, thermal and privacy, and other parameters based on the occupants' needs (Fox and Kemp, 2009). A hypothetical scenario of an interface within Second Life to a physical home that allowed control and monitoring of building systems (e.g., lighting, water usage, etc.) was envisioned. As a proof of concept, a virtual knob (Fig. 19) was modeled within Second Life and linked with a physical light sensor and potentiometer that were attached to a microcontroller (i.e., the Arduino microcontroller). Figure 19 illustrates the data connection between the physical devices and Second Life. The experiment demonstrated that the virtual knob successfully synchronized with the light sensor and potentiometer. The light intensity read by the light sensor affected the brightness of the virtual knob and turning the physical potentiometer rotated the virtual knob.



Use the data to update or manipulate virtual objects

FIG. 19: Data flow between the physical sensors and Second Life (diagram developed by graduate research assistant Spencer J. Lee)

5. BARRIERS TO VIRTUAL COLLABORATION IN SECOND LIFE

The investigations demonstrated opportunities for simulating construction processes and incorporating experiential learning into traditional classroom environments. Despite the above mentioned opportunities a number of obstacles to the implementation and diffusion of those prototypes were observed. First, importing 3D CAD models into certain virtual worlds applications is still limited. With the diffusion of Building Information Modeling we expect that software companies will work together to enable direct data translation between virtual worlds such as Second Life and standard 3D modeling software. The continuing advancements of Building Information Modeling and Virtual Construction technologies mandate research efforts to address successful integration of 4D visualization and intelligent 3D modeling with virtual worlds. Second, virtual worlds incorporate various unrealistic physical properties that conflict with safety training scenarios. For example, Second Life avatars can fly, and earth does not have the physical properties of mass that cause certain soil conditions to cave in. Thus, to utilize Second Life for safety training purposes advanced scripting was employed to apply such properties. Third, from a logistics standpoint, careful role-playing scenarios will have to be developed, to implement pedagogically effective settings that are adequately customized to different size classes and diverse levels of scenario complexities. Fourth, as Second Life is not a goal or end oriented video game, proper feedback systems that assess and guide learners' abilities, need to be integrated into Second Life sessions. This can be facilitated through on-screen dashboards, text messages, automated agents, etc. Fifth, the level of detail of construction activities requires careful coordination when simulating labor or equipment based procedures for construction work. In other words, productivity rates and activity durations are not going to be realistic and thus such factors need to be considered during scenario developments. Sixth, the development of an open equipment and temporary works library would require a common protocol for geometric modeling, feature

scripting, and model ownership, file format, equipment size, type, control rules, etc. We further describe the issues of interoperability, model view, and limitations of custom programming.

Interoperability

The modeling tools available in Second Life use basic geometric shapes of objects called ‘prims’ to create graphic content or buildings. The model can be made realistic by mapping texture of real-world objects. However, to make the models more realistic and appealing, the users need to achieve expertise over certain tools available in Second Life as well as third party programs. When comparing the purpose-built 3D models produced in a CAD or BIM software environment, Second Life modeling lacks not only accuracy but is also more tedious to achieve a similar level of representation. Thus, it is imperative that the Second Life environment supports interoperability with external modeling software. Many institutes such as the Delft University of Technology has been developing third-party plug-in software for CAD software (e.g., AutoCAD, Maya, 3D Max) to resolve interoperability issues (Ku and Gaikwad, 2009). In the method adopted by the authors which adopted a middleware software (i.e., AC3D), the imported objects are broken down into additional numbers of faces and as a result the imported model may generate an incomplete 3D model because of the limitation of number of prims that are allowed per parcel within Second Life. Also, conical and cylindrical objects cannot be imported in SL using this method.

Multiple Model Views

The representation of a building is a translation of an abstract concept into a tangible graphical form (Boeykens, 2008). As illustrated in the following figure, Boeykens (2008) suggested that Building Information Modeling should present the user with a choice of representations, each displaying a part of the project data in an optimized form, and thus the representation should not be limited to 2D and 3D views (Fig. 20).

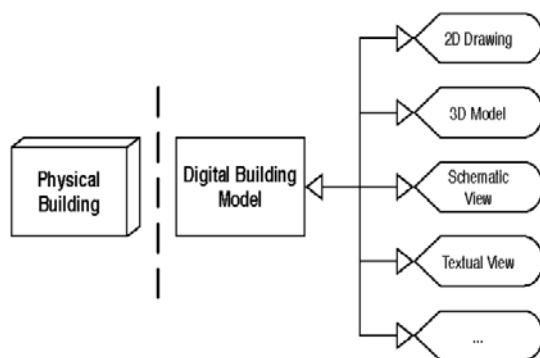

FIG. 20: Ways of representation of a digital model: Adopted from Stefan Boeykens (2008)

Current Virtual Worlds do not support multiple representations of a 3D model which limits the level of detail that is required to produce multiple views and accurate construction drawings. Builders in traditional construction practice require construction drawings in 2D format and Virtual Worlds’ inability to produce 2D drawings will be a potential problem in implementing virtual worlds as an ‘integration tool’.

Unrealistic Behavior of Avatars and Limitations of the Scripting Interface

The users of Second Life use the Linden Scripting Language (LSL) as their client programming interface to control the behavior of an avatar and to add functionality to objects (prims). The prim in combination with LSL known as a sculpted prim can produce animated behavior and simulations for various purposes. LSL is a fairly simplified scripting language targeting laymen who are not professional programmers, to script and customize such behavior or functions. The syntactic style of the LSL language is similar to that of C or Java. The text in the script is compiled into an executable byte code which is set to run within a virtual machine on the Second Life main server. However, LSL contains many limitations for the end user to replace variables and parameters which pose difficulties of updating models and linkages with other data files such as construction schedules and models. To address part of the above shortcomings of the Linden Scripting Language the authors developed an LSL script that communicated with an HTML and PHP script to enable custom user input without having to change the LSL scripting (Fig. 21).

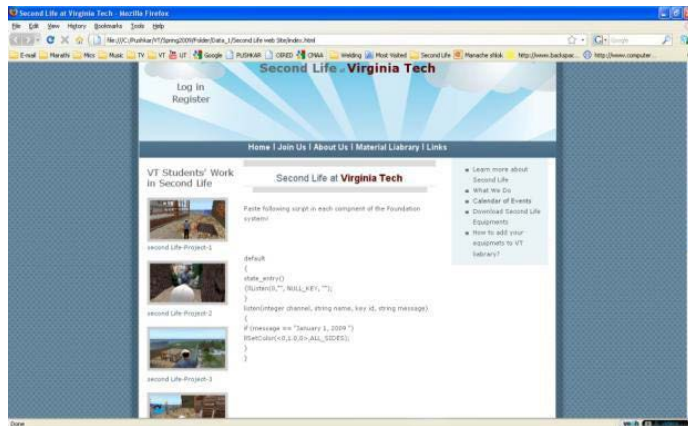

FIG. 21: Webpage interface to auto generate LSL scripts

6. CONCLUSIONS

Based on our explorations in Second Life, the authors propose that the concept of BiM offers new means to engage dispersed and traditional classroom students to interactively study the construction process of buildings. Role-playing would add value to the understanding of activity sequencing, crew coordination, and interface management, safety training, design reviews, and building operation management which are often limited in traditional educational settings. The authors plan to further evaluate the impact of the proposed BiM scenarios with a sample of undergraduate and graduate students at Virginia Tech.

In addition to students' participation as trainees within simulation scenarios, the authors also envision students' proactive participation as creators of an open object library of construction equipment and temporary works. Thus, besides utilizing Second Life as a training environment, there is also a need to teach students modeling and scripting skills for designing process components. The pedagogical aspect of involving students in this process is twofold: (1) students will gain a deeper understanding of construction equipment and temporary works by building it themselves, and (2) they will be contributors to an open learning environment that will not only benefit themselves and their peers, but a larger community of construction students.

In the past, virtual worlds have been explored as a sketching tool or a means of visualization and communication aimed to satisfy the tasks in the early phases of design for architectural collaboration (Maher et al., 2005; Nederveen, 2007; Chase et al., 2008). Introduction of Building interactive Modeling expands the previous approaches and successfully adapts virtual worlds to support construction education and incorporate various users' perspectives to access, manage, and update project data that ultimately fosters construction integration. Future research in the area of multiple view representation, interoperability, and archival of models will synchronize this dynamic environment of virtual worlds with current BIM tools. Building interactive Modeling will leverage participants' knowledge for better scope management and collective decision making. Two future research areas that can further enrich the BiM framework are suggested:

Integration of CAD/Modeling software and Real-time Review of Design Options

Interoperability of Virtual Worlds with other traditional CAD software is necessary as the current virtual worlds environments do not support precise 2D drawing and 3D modeling tasks. While virtual worlds environment such as Second Life offer a shared modeling space and a real time interface, they currently do not provide functions for simultaneous review of multiple design options which should be addressed by combining external 3D models and databases with the virtual worlds environment.

Agent Based Modeling

This type of modeling can be used to analyze differing behavioral complexity of various scenarios by producing dynamic virtual environments. 3D objects can react dynamically with simple scripted behaviors that are triggered by events. Agents perceive their environment through sensors and use a reasoning process to act in the

world using their effectors. As compared to the scripted behavior of objects, agents are created by using programming language to provide them with the ability to carry out a complex reasoning and ultimately produce dynamic behavioral complexity (Maher and Merrick, 2005). This type of modeling system will be effective for construction safety planning and training.

7. REFERENCES

- Addington, M. and Schodek, D. (2005). *Smart materials and technologies*, Elsevier, Architectural Press.
- ASCE Body of Knowledge (BOK2) (2008). "Civil Engineering Body of Knowledge for the 21st Century: Preparing the Civil Engineer for the Future". Second Edition, American Society of Civil Engineers, 2008.
www.asce.org/bookstore/book.cfm?book=8241 accessed on
- Boeykens, S. (2008). Representational Limitations and Improvements in Building Information Modeling, *Education in Computer Aided Architectural Design in Europe (eCAADe)*, edition: 26, 17-19 September, Antwerpen, Belgium.
- Carvajal, A. (2005). The Use of Visualization Technologies for the Integration of Building End-User Perspectives, a Managerial Approach. *Proceedings of American Society of Civil Engineers (ASCE) conference*, Vol. 179.
- Chase, S., Schultz, R., Brouchoud, J. (2008). Gather 'round the Wiki-Tree: Virtual Worlds as an Open Platform for Architectural Collaboration", in ARCHITECTURE 'in computro': Integrating Methods and Techniques, *Proceedings of the 26th Conference on Education in Computer Aided Architectural Design, (eCAADe) Europe*, Antwerp, 809-815.
- Chiu, H. (2009). Research on Hybrid tectonic methodologies for responsive architecture, *CAADRIA 2009*
- Del Villar, D. and Pollalis, S.P. (2007). *Understanding outsourcing architectural services*, Harvard Design School, Design and Technology Report Series.
- The Economist, "Getting Serious," 6th December 2007, https://www.economist.com/search/displaystory.cfm?story_id=10202591, accessed on 2/22/08
- Egan, J. (1998). Rethinking Construction. London, the Report of the Construction Task Force to the Deputy Prime Minister. <http://www.azobuild.com/details.asp?ArticleID=2866>
- Fischer, M., Haymaker, J., Liston, K., (2003) "Benefits of 3D and 4D models for facility managers and AEC service providers," *4D CAD and Visualization in Construction: Developments and Applications, 2003*, A.A. Balkema Publishers
- Foster, A.L. (2006). The Chronicle of Higher Education, Harvard to Offer Law Course in 'Virtual World', 8th September 2006, <http://chronicle.com/article/Harvard-to-Offer-Law-Course-in/32352> accessed on 6/25/2010
- Fox, M. And Kemp, M. (2009). *Interactive Architecture*, Princeton Architectural Press, New York.
- Green, K.E. and Gross, M.D. (2009). Architectural Robotics: Intelligent and adaptable built environments, *UbiComp2009*, Sep 30- Oct 3, Orlando, FL, USA
- Haque, M. and Shah, G., (2007) "4D Construction Visualization: Techniques with Examples," *2007 ASEE Annual Conference & Exposition (ASEE Conferences Excellence in Education)*

- Huang, T., Kong, C., Guo, H., Baldwin, A., Li, H. (2007). A virtual prototyping system for simulating the construction process, *Automation in Construction*, 16, 576-585
- Issa, R.R.A. (2000). Virtual Reality: A Solution to Seamless Technology Integration in the AEC Industry, *American Society of Civil Engineers (ASCE)*, Vol. 278, 1011-1012.
- Kamat, V. and Martinez, J. (2000) "3D visualization of simulated construction operations," *Simulation Conference Proceedings, 2000. Winter*, Orlando, FL, USA
- Kang, S. and Miranda, E., (2006) "Planning and visualization for automated robotic crane erection processes in construction," *Automation in Construction*, Vol. 15, Iss. 4, 398-414
- Kizil, MS, and Joy, J.,(2001) "What can Virtual Reality do for Safety?" *The University of Queensland, Minerals Industry Safety and Health Centre*.
- Koskela, M., Kiltti, P., Vilpola, I., and Tervonen, J. (2005). Suitability of a Virtual Learning Environment for Higher Education, *The Electronic Journal of e-Learning*, Vol. 3, Iss. 1, 21-30.
- Ku, K. and Gaikwad, Y. (2009). Construction Education in Second Life, *Construction Research Congress*, University of Washington, Seattle, Vol. 339, 1378-1387.
- Latham, M. 1994. "Constructing the Team." Final Report of Procurement and Contractual Arrangements in the UK Construction Industry HMSO London.
- Lucas, J. and Thabet, W. (2008), *Implementation and evaluation of a VR task-based training tool for conveyor belt safety training*, ITcon Vol. 13, Special Issue, Virtual and Augmented Reality in Design and Construction, 637-659
- Maher, M.L., Ahmed, A., Egan, S., Macindoe, O., Marchant, D., Merrick, K., Namprempre, K., Rosenman, M., Shen, R. (2005). Design World: A tool for team collaboration in high band virtual environments, Report Project 2002-024-B/Report 31-12-2005-01, <http://eprints.qut.edu.au/27024/> accessed on 6/25/2010
- Maher, M.L. and Merrick, K. (2005). Agent Models for Dynamic 3d Virtual Worlds, *Proceedings of the 2005 International Conference on Cyberworlds*, 27-34.
- McGrawHill (2009). SmartMarket Report, The business value of building information modeling: getting building information modeling to the bottom line.
- Messner, J. and Horman, M., (2003) "Using Advanced Visualization Tools to Improve Construction Education." *Proceedings of CONVR 2003*, Virginia Tech, USA.
- Miller, C. L. and Bertoline, G. R. (1991). Spatial Visualization Research and Theories: Their Importance in The Development of An Engineering And Technical Design Graphics Curriculum Model, *Engineering Design Graphics Journal*, Vol. 55, No.3, 5-14.
- Mitchell, W.J. (2008). "Foreword - Virtual worlds, virtual prototypes, and design," *Virtual Futures for Design, Construction & Procurement*, Brandon, P. and Kocaturk, eds., Blackwell Publishing, xiv-xx
- Nayak, N., and Taylor, J. (2009). "Offshore Outsourcing in Global Design Networks," *ASCE Journal of Management in Engineering*, Vol. 25, Iss. 4, 177-184.
- Nederveen, S. (2007). Collaborative Design in Second Life, *Second International Conference World of Construction Project Management*, 24-26 October, Delft, Netherlands.

- Rowlinson, S. and Hadikusumo, B.H.W., (2003) "Virtually real construction components and processes for design-for-safety-process (DFSP)," *4D CAD and Visualization in Construction: Developments and Applications*, 2003, A.A. Balkema Publishers
- Sacks, R. and Barak, R. (2009). Teaching building information modeling as an integral part of civil engineering in freshman year. *ASCE Journal of professional issues in engineering education and practice*, Vol. 136, No. 1, 30-38.
- Sawhney, A. and Mund, A. (1998). Simulation Based Construction Management Learning Systems, *Proceedings of the WinterSimulation Conference*, 1319 – 1324.
- Stothers, N., (2007) "The use of Virtual Reality simulation in the Education and Training of Construction Managers. Are the British going Dutch?" *Second International Conference World of Construction Project Management*, October 24-26, 2007, Delft, The Netherlands
- sweden.se: the Official Gateway to Sweden, "Sweden Opens Virtual Embassy 3d-Style" 30th May 2007. <http://www.sweden.se/eng/Home/Lifestyle/Reading/Second-Life/> accessed on 6/25/2010
- Treichler, D. (1992). Projected Instructional Media: The Good the Bad and the Ugly, *Annual ASEE Conference*, Toledo, OH.
- Walker, V.L. and Rockinson-Szapkiw, A. (2009). Educational Opportunities For Clinical Counseling Simulations In Second Life, *Innovate: Journal of Online Education*, June-July, Vol.5, Issue 5.