

The Walls of Dongshuiguan Island

Zhuying Sun

Thesis submitted to the faculty of the Virginia Polytechnic Institute and State University
in partial fulfillment of the requirements for the degree of

Master of Architecture

H. Scott Gartner

Humberto Rodriguez-Camilloni

Paola Zellner Bassett

September, 2019
Blacksburg, VA

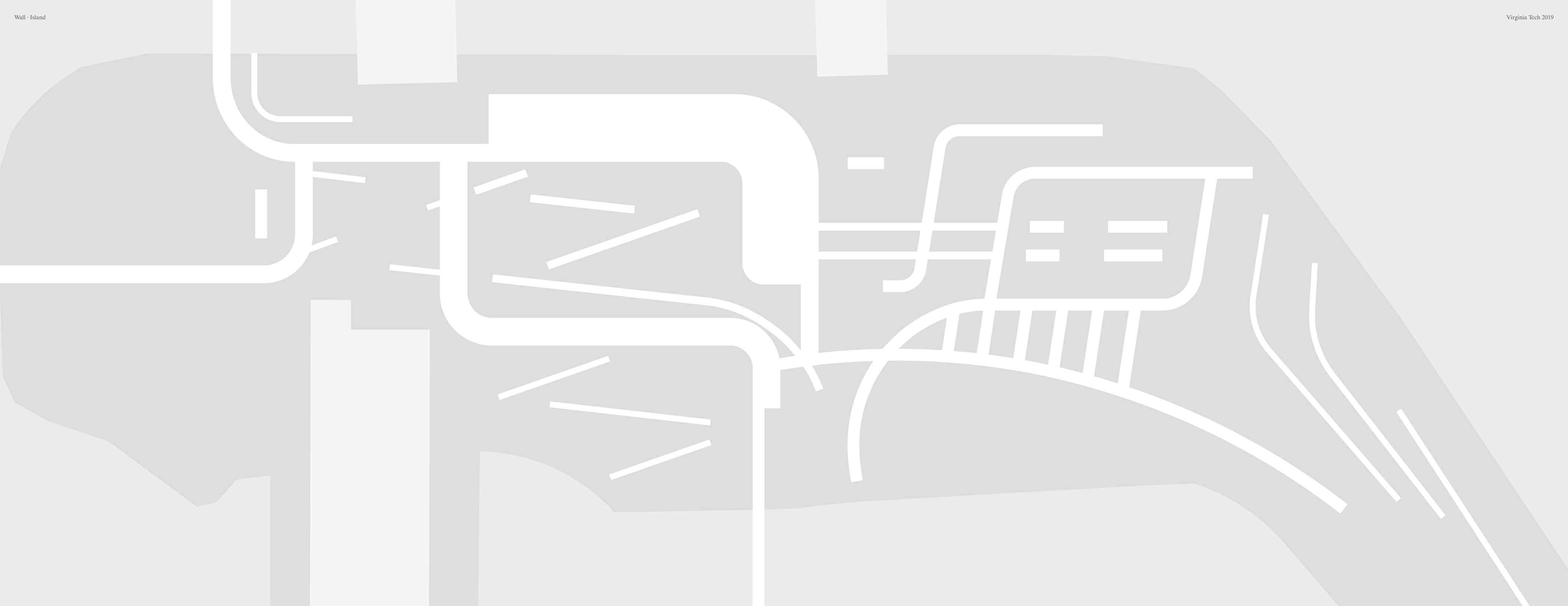

Abstract

Walls are important elements in architecture design history. Walls have been used as barriers and as structural elements as well. The biggest scale of a wall is a city wall which can protect the whole city area as a fortification--boundary. Another scale is the wall around buildings, which can define a site, a landscape, and separate a building from its surroundings. At a smaller scale, walls divide spaces in buildings. From ancient times to modern times, the wall was developed into various shapes and functions with different kinds of materials. This thesis is a study of walls of different scales and their harmonious whole. I am very interested in the city walls of Nanjing, a famous Chinese old city very close to where I was born. These city walls were built more than 200 years ago. These old walls are combined with new walls to make a space for communication and a new public attraction for the city. People can see the walls, feel the walls and then know much about the walls and architectural space. Wall gallery, visitor center and cafe/gift shop are located in this wall garden that I call "Paradise Island".

Keywords

Wall, Island, Garden, Wandering, Heavy and light, Brick and Concrete

Acknowledgements

I would like to thank my committee members, Scott, Bert and Paola. Without their support and guidance, I wouldn't have made my thesis this far.

At the same time, I would like to thank my parents and friends who gave me consistent help and support in my two-year study in the United States. Without their reassurance, I wouldn't have achieved my growth and success. Thank you! I love you all!

Contents

Title	1
Abstract	4
Acknowledgements	5
Contents	6
Introduction	8
Design Strategies	10
Case Study	11
Site Study	23
Design Process	33
Final Scheme	49
Conclusion	74
Bibliography	76
Image Credits	77

“The wall did well for man. In its thickness and its strength, it protected man against destruction. But soon, the will to look out made man make a hole in the wall, and the wall was pained and said, ‘What are you doing to me? I protected you; I made you feel secure—and now you put a hole through me!’ And man said, ‘But I see wonderful things, and I want to look out.’ And the wall felt very sad.

Later man didn’t just hack a hole through the wall, but made a discerning opening, one trimmed with fine stone, and he put a lintel over the opening. And soon the wall felt pretty well.”

— Louis I. Kahn

“Architecture appears for the first time when the sunlight hits a wall. The sunlight did not know what it was before it hit a wall.”

— Louis I. Kahn

Louis I. Kahn said to brick, "What do you want, brick?"
And brick said to him, "I like an arch."

I said to wall, "What do you want, wall?"
And wall said to me, "I like a curve and a corner."

Introduction — Wall · Island

I started my thesis by studying different scales of walls in buildings. The wall is an important element in architecture which has various shapes, scales and functions, sometimes evoking different feelings. Walls inside buildings divide and define rooms. External walls and bounding walls define a site. The city wall is the boundary of a city with a defence function. They all represent a certain scale of space and feeling. I use different scales of walls to build a fantastic place for people to experience new walls and old city walls, to feel the magic of history written in them. Personally, I know the importance of Nanjing City Wall because this city is close to where I was born. So I chose the old city wall in Nanjing as my design site. It was built with traditional Chinese bricks and stones, standing there as an important defense barrier for more than 200 years. However, many people do not know the city wall's significance in architectural history. I hope my new designed walls can act as a bridge between people and their heritage and let them know and experience walls in a new and interesting way. New walls and old walls are combined together to create a place for communicating, experiencing, and learning, which will activate this city environment.

However, many parts of Nanjing city wall were destroyed by war and human activities during this long period of time. There are many breaks and losses. I chose one part of this long city wall which is composed of two smaller walls and one longer wall. These three walls connect an island to the banks of the river. This island is surrounded by Qinhuai River. The longer wall stretches to the southern part of Nanjing city wall but there is a large break between the northern part and these two small walls. This long city wall was also a water gate in ancient times. As a result, this island can be a starting point for visiting the southern part of the city wall as well as a good place for people to experience this heritage. The new walls on this island create a visitor center including a gallery, a communication space and a information room for people to learn about the city wall and experience different walls and the spaces they create. Different ways can lead the people to this island: walking through three city walls, walking across a big bridge which connects to the main street, or by taking boats to a landing. Different circulation directions create various opportunities for the placement of the new walls.

After doing some research on this site, I began my design focusing on the entrances and the layout of the site. The new walls can guide people to different small wall-gardens and indoor spaces. Indoor spaces are divide into two main parts—a gallery and a tower.

In the gallery, one big thick wall becomes rooms for service and digital exhibition. The diagonal walls starting from the southern entrance can extend the exhibition walking pass. When people enter this space they will see the room with sharp corners in contrast to straight walls outside. At the same time, they will see light and shadows created by skylights with the same shapes. When people wander in this gallery, they have the chance to touch and feel the materials, the light and the legacies of history.

Then they can walk to the second floor and go through the wall bridge to the tower. The tower will be information and communication space. With four concrete walls supporting the tower in the center, it creates more free space for people to go up and stand at a high point to see the view of this ancient city.

The gallery mainly uses brick masonry and the tower uses mainly concrete. The material differences generate a feeling of contrast. One is thick, rough and short. The other is thin, smooth and tall. People will respond differently to this materiality diversity.

The outdoor walls also form several small gardens which definitely become part of the landscape of this island and naturally evoke different feelings. At the same time, people will be stimulated to have more interactions with walls which serve various functions including blocks, exhibitions and installations.

All in all, this thesis focuses on how to use new walls to created a dialogue between the history, the environment and people.

Design Strategies

- 1.** Using walls and landscape to form different small environments which can be the place for rest, communication and activity.
- 2.** Two main materials can create different spatial feelings: thick wall -- brick masonry thin wall -- concrete.
- 3.** Thickness, material, and shadow change in this building, enriching people's experience.
- 4.** The arch is an important form of opening on the old city wall. Utilizing this form increases possibilities of interaction between old and new walls.
- 5.** As the edge of a space, a wall can define the space and circulation.
- 6.** A wall itself can be space and room (shown in plan and section).
- 7.** Materials and details are most important in the design of this building.

Case Study

Through different case studies, I got a deeper understanding of walls of different scales. These cases provide various possibilities for designing walls, which is an excellent inspiration for me.

More is more

21st Century Museum of Contemporary Art / SANAA

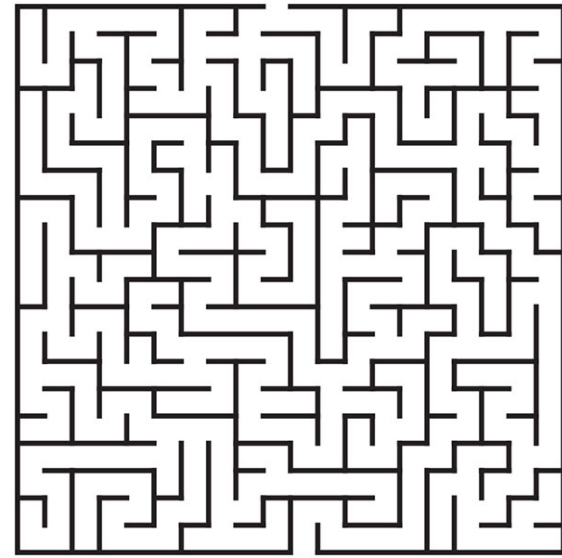
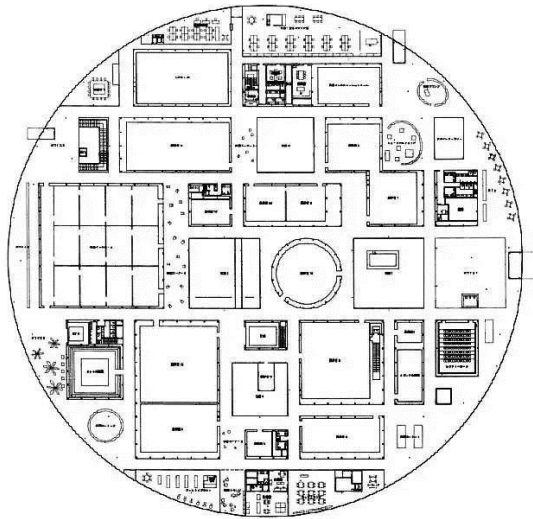

Less is more

Barcelona Pavilion / Mies van der Rohe

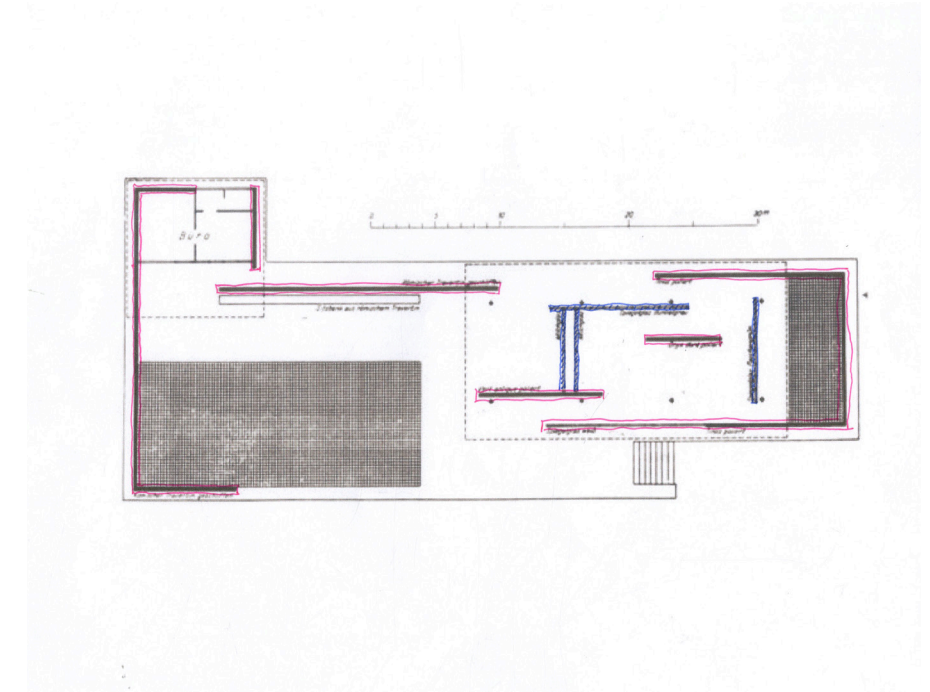

More is unlimited

Kanagawa Institute of Technology Workshop / Junya Ishigami

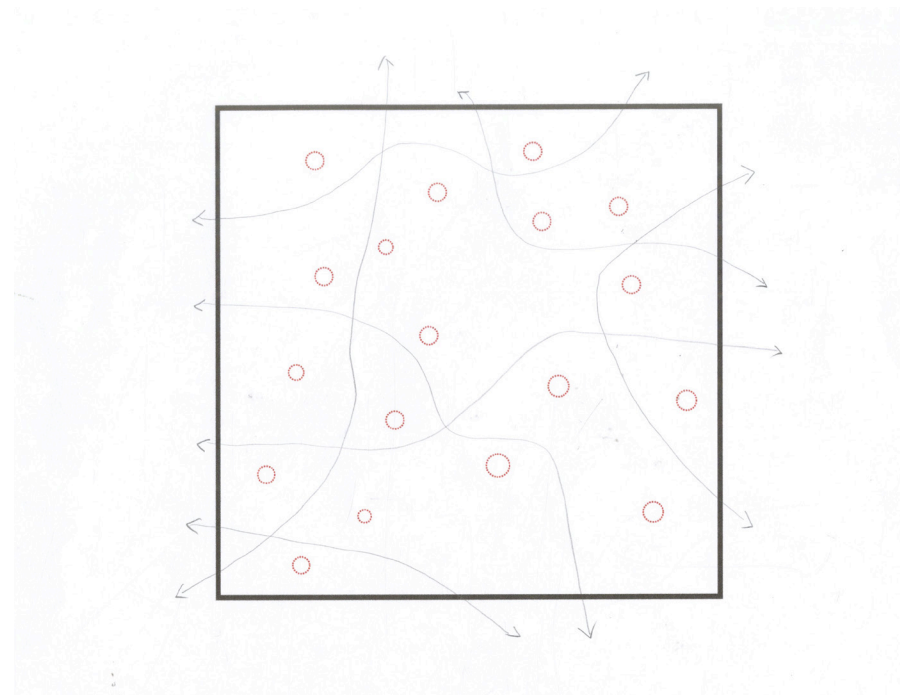
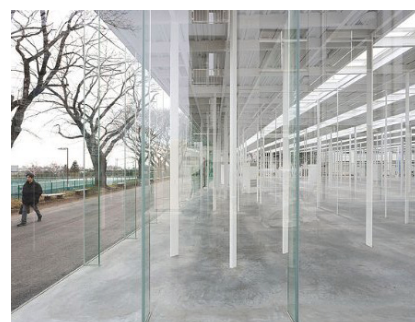

Less is unlimited

Blossom Pavilion / Atelier Deshaus Shanghai

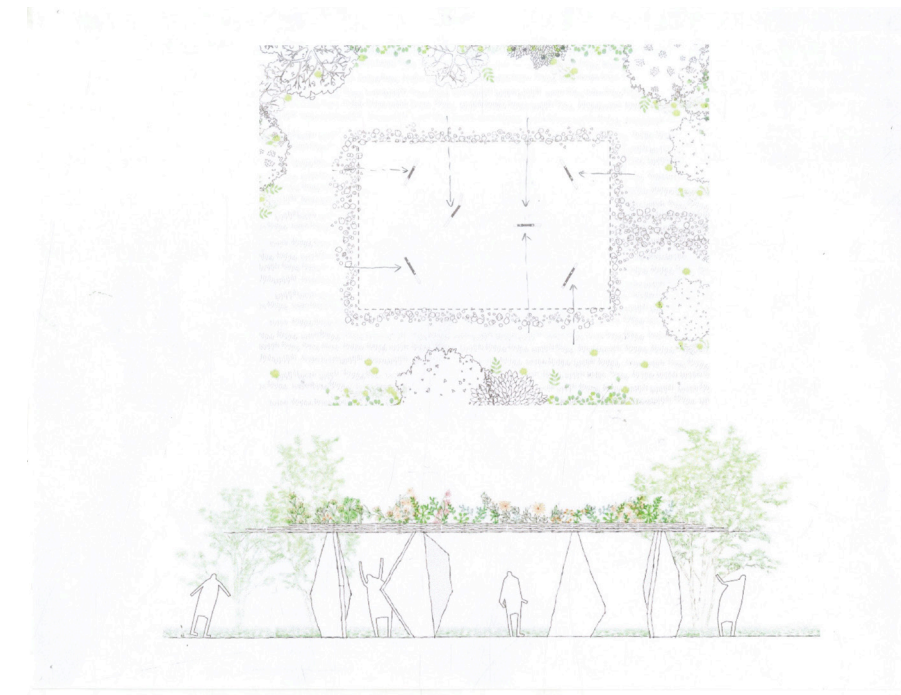
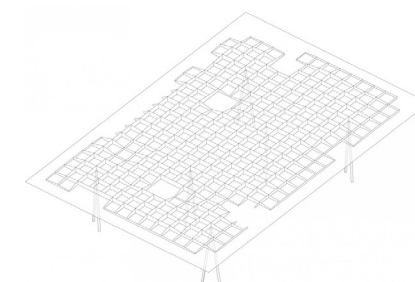

Stack Sections

New Tampere Art Museum / 3Gatti Architecture Studio

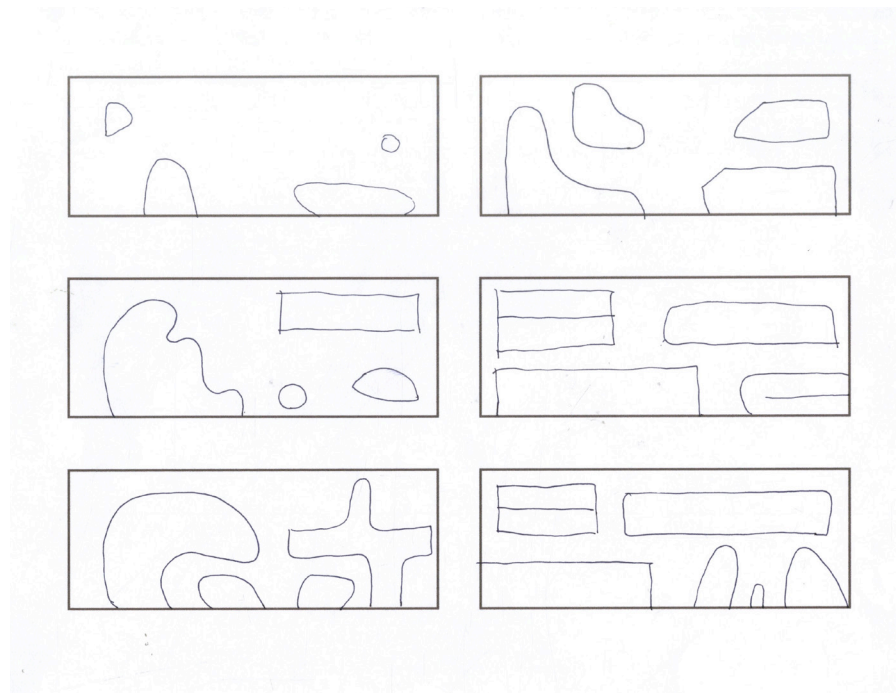

Sections and Possibilities

Volcanic D2C Flagship Store / 3Gatti Architecture Studio

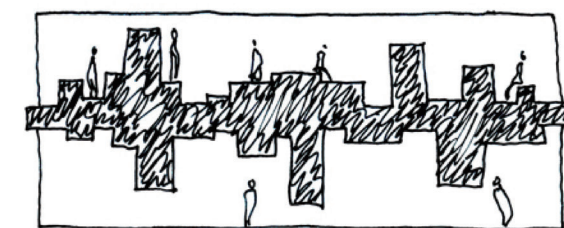
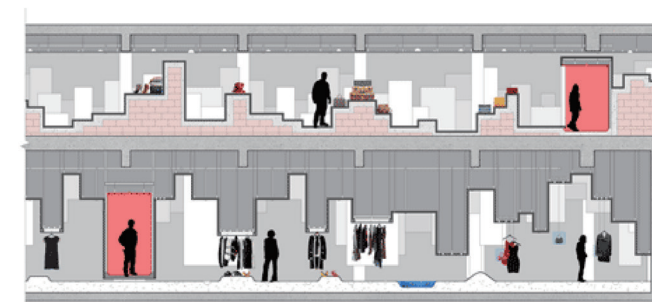
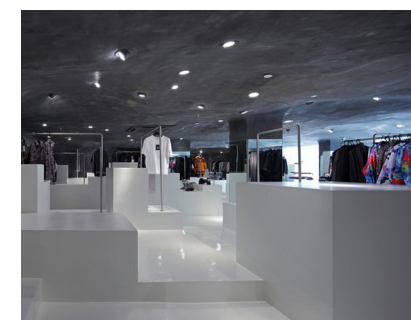
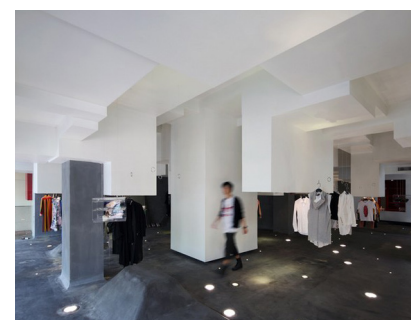
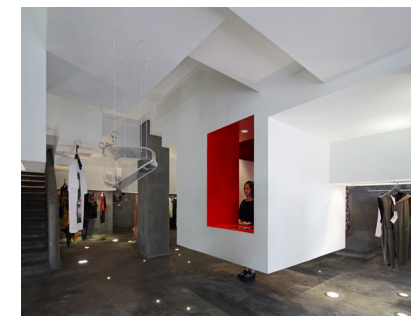

Between Buildings

Enframed scenery is the result of breaking limits.

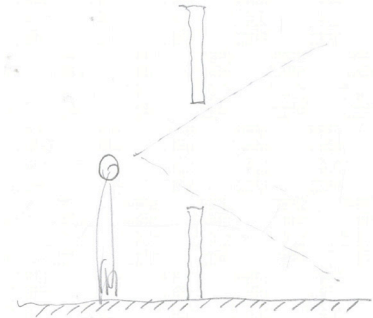
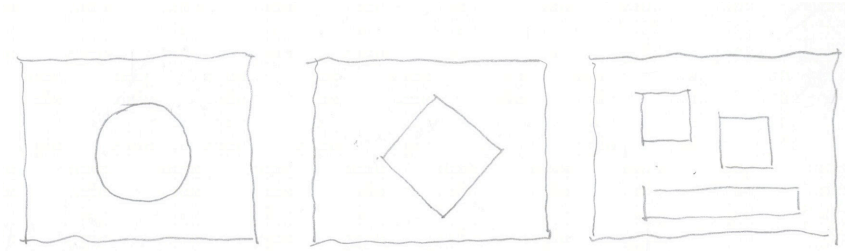

Between Buildings

A spirit screen, also called spirit wall or screen wall, is used to shield an entrance gate in traditional Chinese architecture. Spirit screen is used for keeping out wind, line of sight and the evil-doing. It also creates a feeling of boundary.

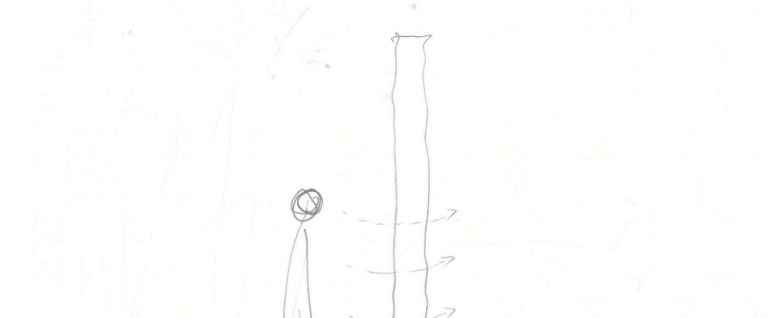
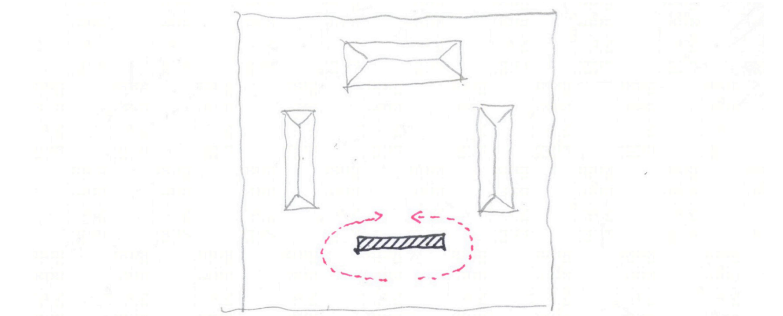

City Walls

Traditional Chinese city walls and European city walls

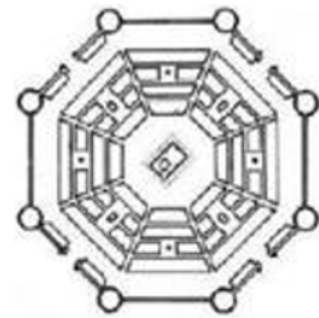
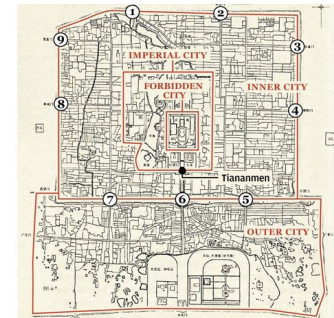
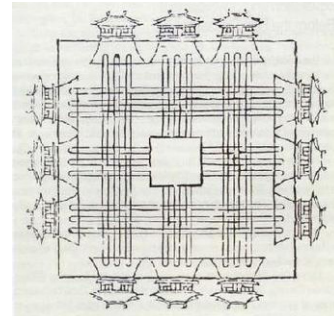

Chinese City Walls

European City Walls

City Walls

Nowadays, skylines of modern cities can be another kind of city wall as well.



Shanghai



Hong Kong



Tokyo



Kyoto



Jakarta



Singapore

Walls Between Countries

The Great Wall in China is the barrier between ancient Chinese dynasties and the Huns. Berlin Wall divided Germany into two parts after world war II, which was the result of new international political structure. And the Mexico–United States barrier wall is another example of wall between countries.



Site Study

After case studies, I began to select an appropriate site for my new designed walls. Nanjing is an ancient city in China which is more than 2000 years old and is very close to where I was born. It was the capital of six dynasties. The city wall we can see today was built in Ming dynasty which was 200 hundreds years ago. While because of World War 2 and people's actions, it was partly damaged. The site I chose is an example of damage but also an opportunity for designing new walls. Current entrances, unique connections between the island and the city wall, and the beautiful vegetation make this site an exciting place for new creations.



Map of China

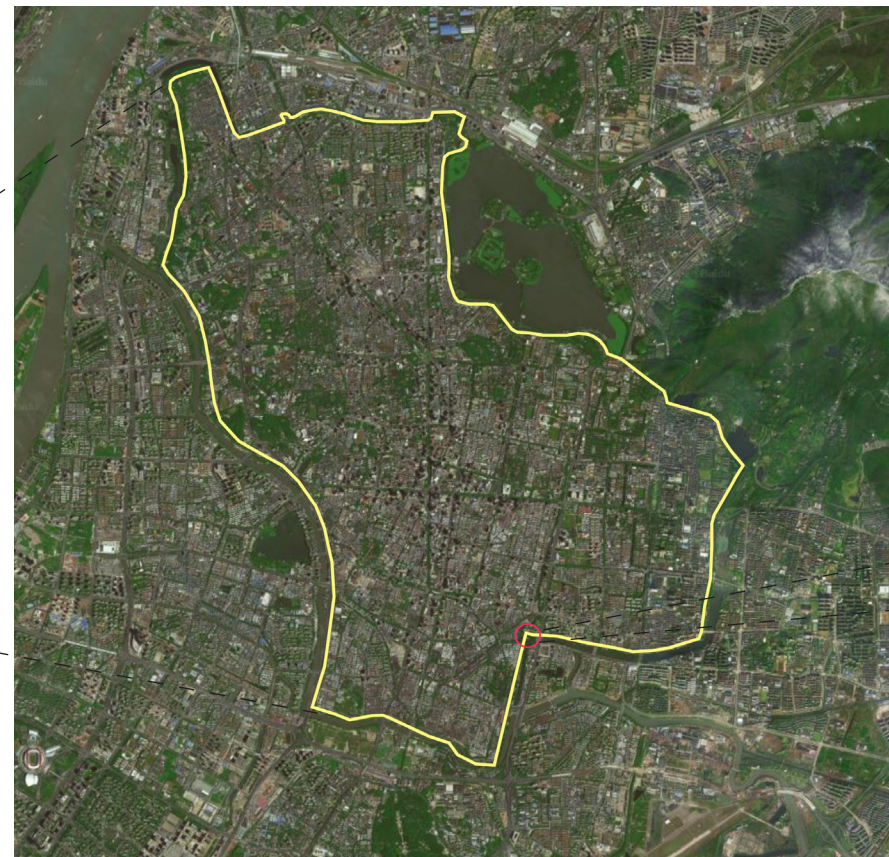

Map of Nanjing and the scope of current city wall



Map of the site: Dongshuiguan Island

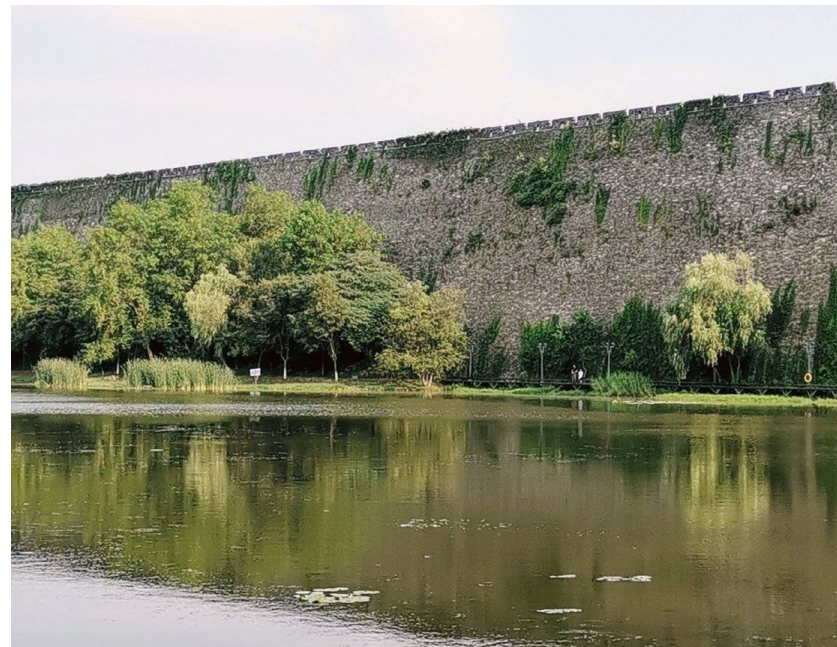
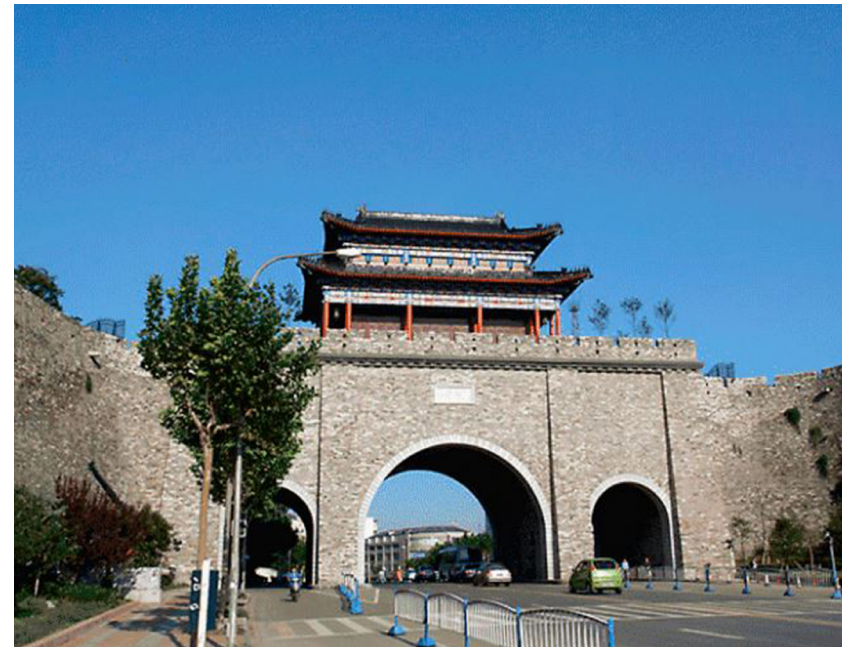

Some photos of Nanjing City Wall

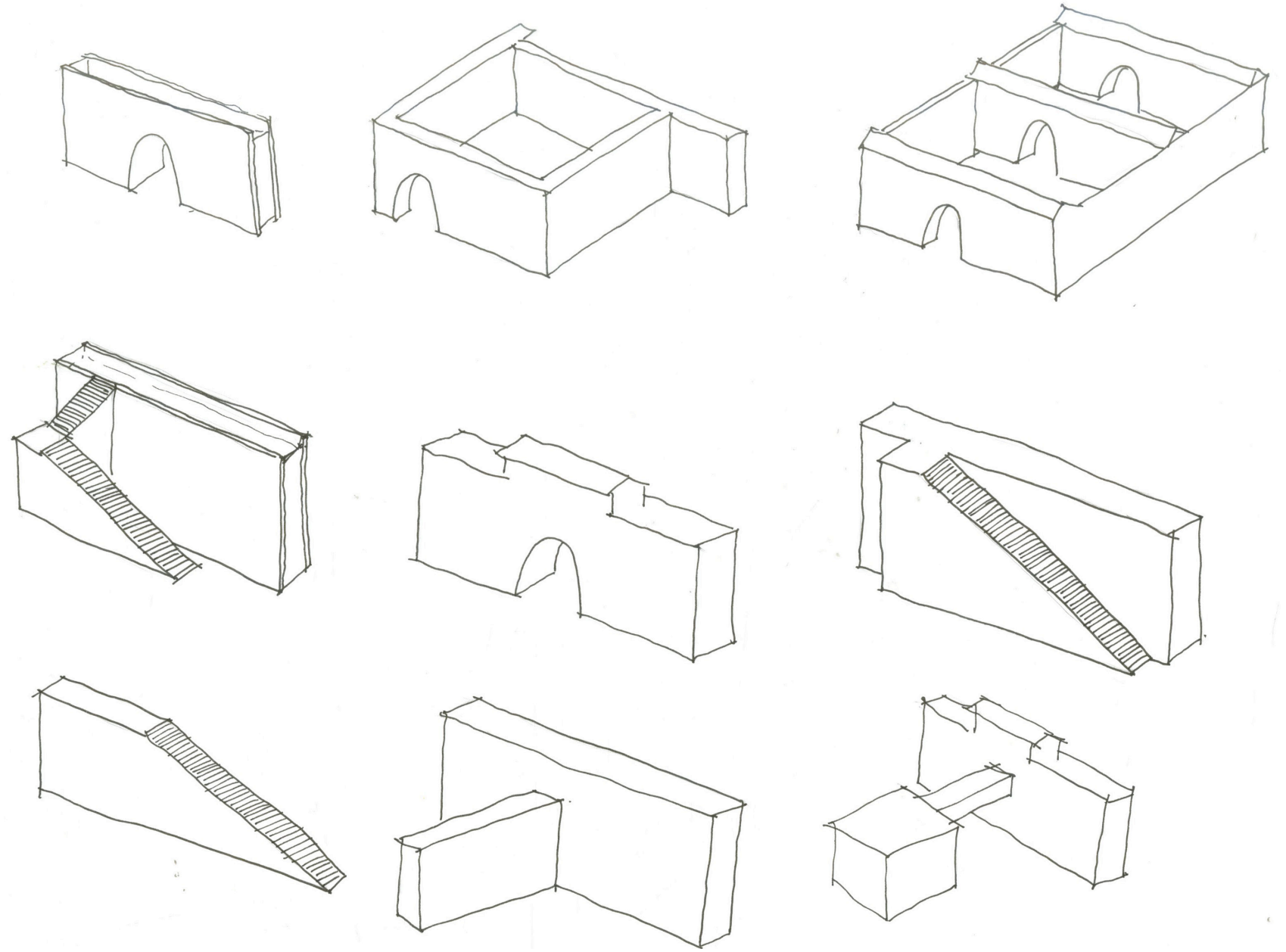

Studying different forms of Nanjing City Wall

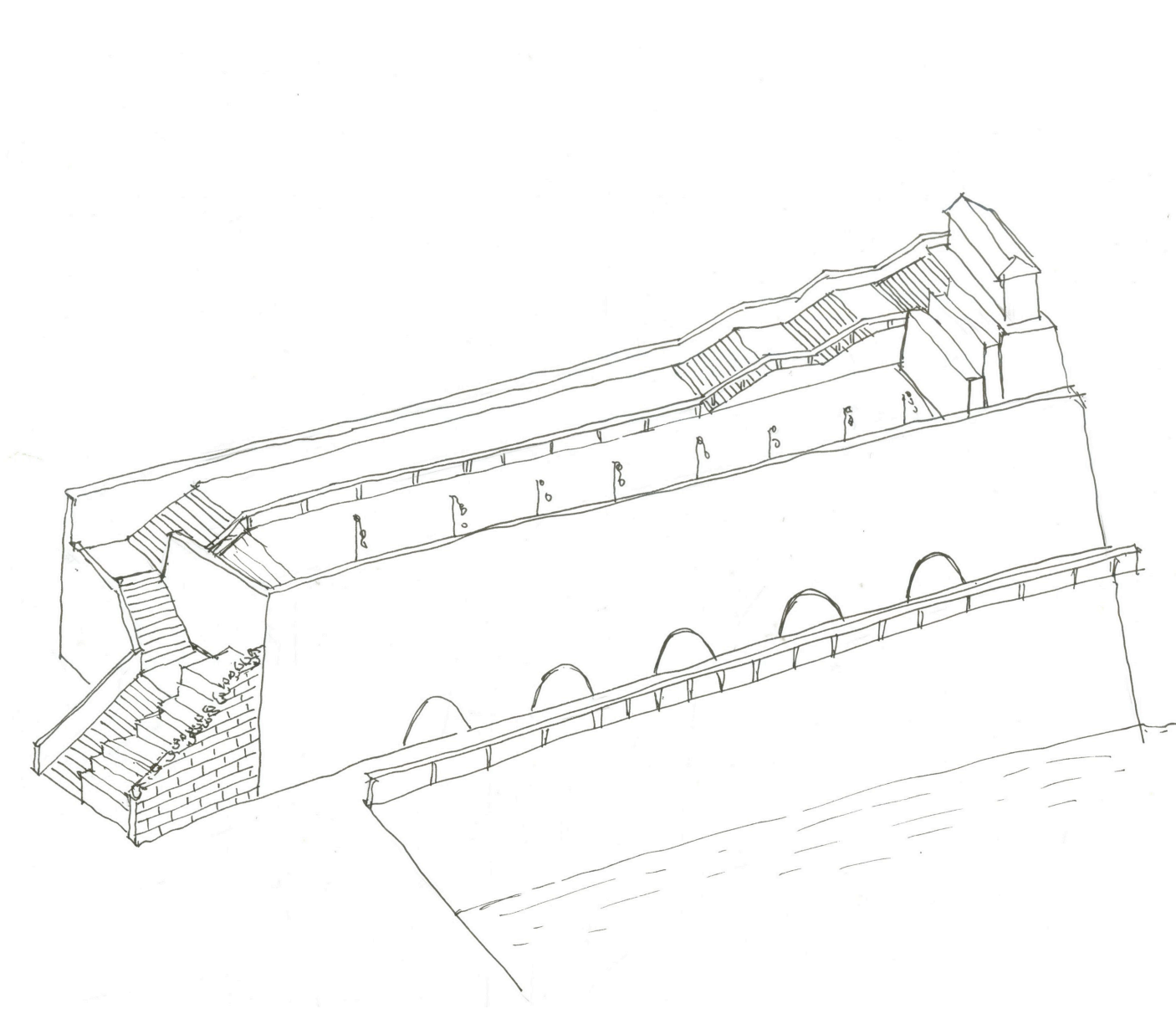

Site photos

Sketch of the biggest city wall on this site



Original site plan

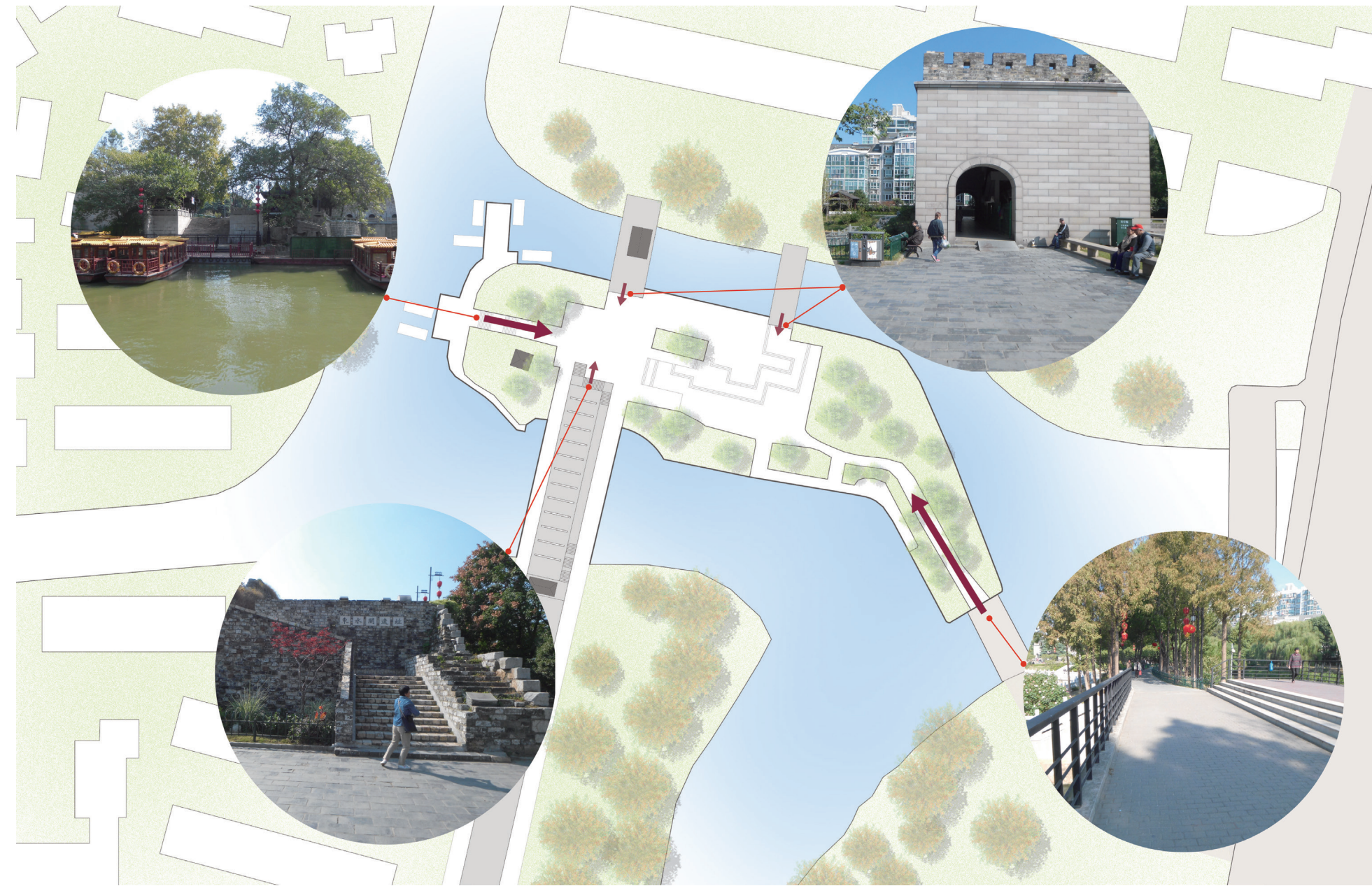

Entrance and circulation

Design Process

Starting from trying various form studies, I found that curve is a good way to stimulate free wandering. Also it is important for me to define different kinds of walls, which will definitely have significant influences on spaces. Combined with circulation requirements, light effects and feelings and the usage of spaces, the design of new walls should present the core idea of showing the charm of walls. This process helped me to reach the right direction finally.

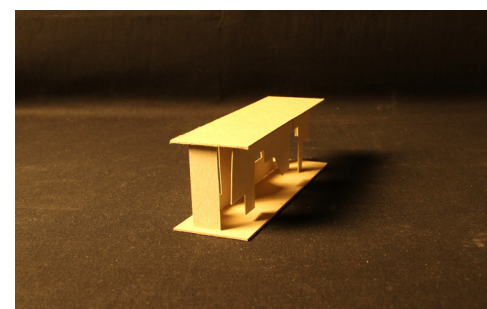
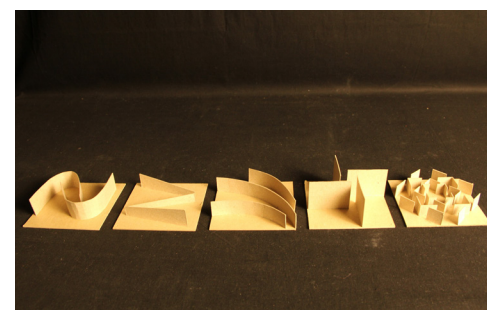
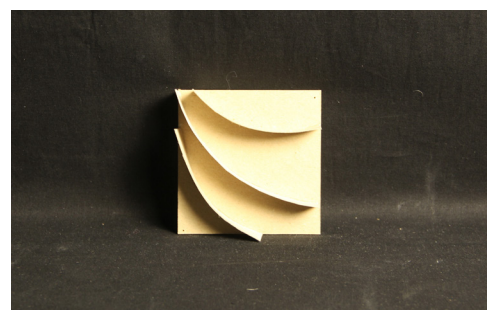
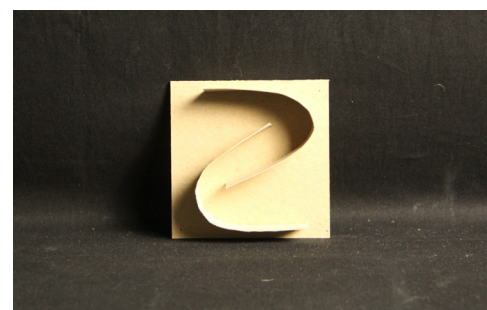
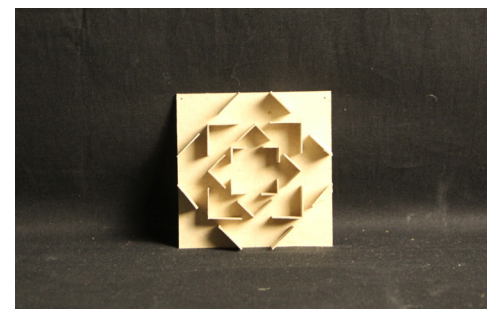
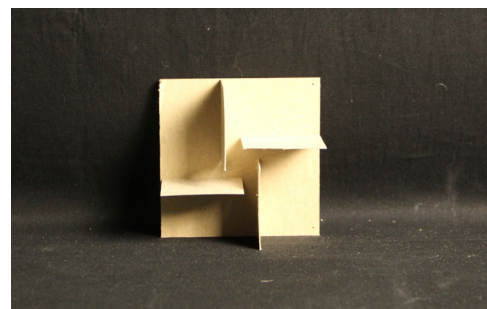
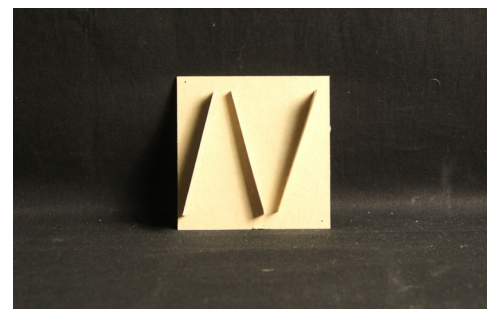

Form studies in plans and sections

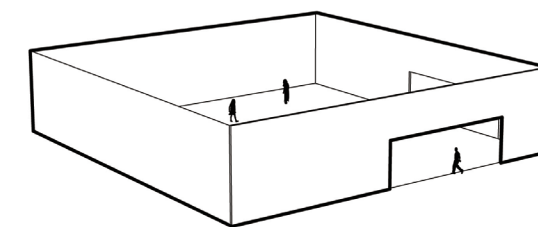
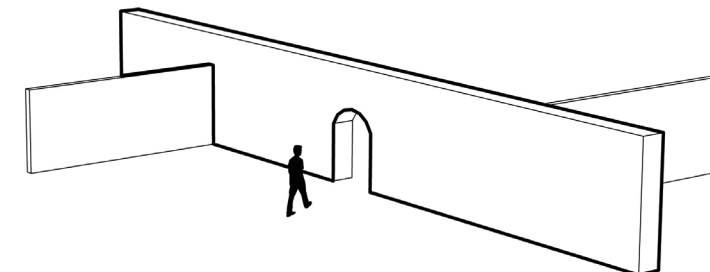
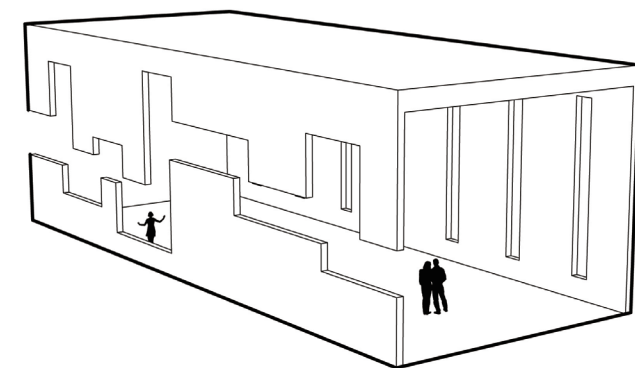

Wall is not just a simple structure between two spaces. Wall has many possibilities. Here I studied three forms of walls. The first one is that a thick wall itself can be a designed space for people to go through and have a view in it. The second one is a barrier between two spaces but it is thick enough for people to experience the material and thickness of a wall. The last one is the space created by several walls, which shows the enclosure function of walls.

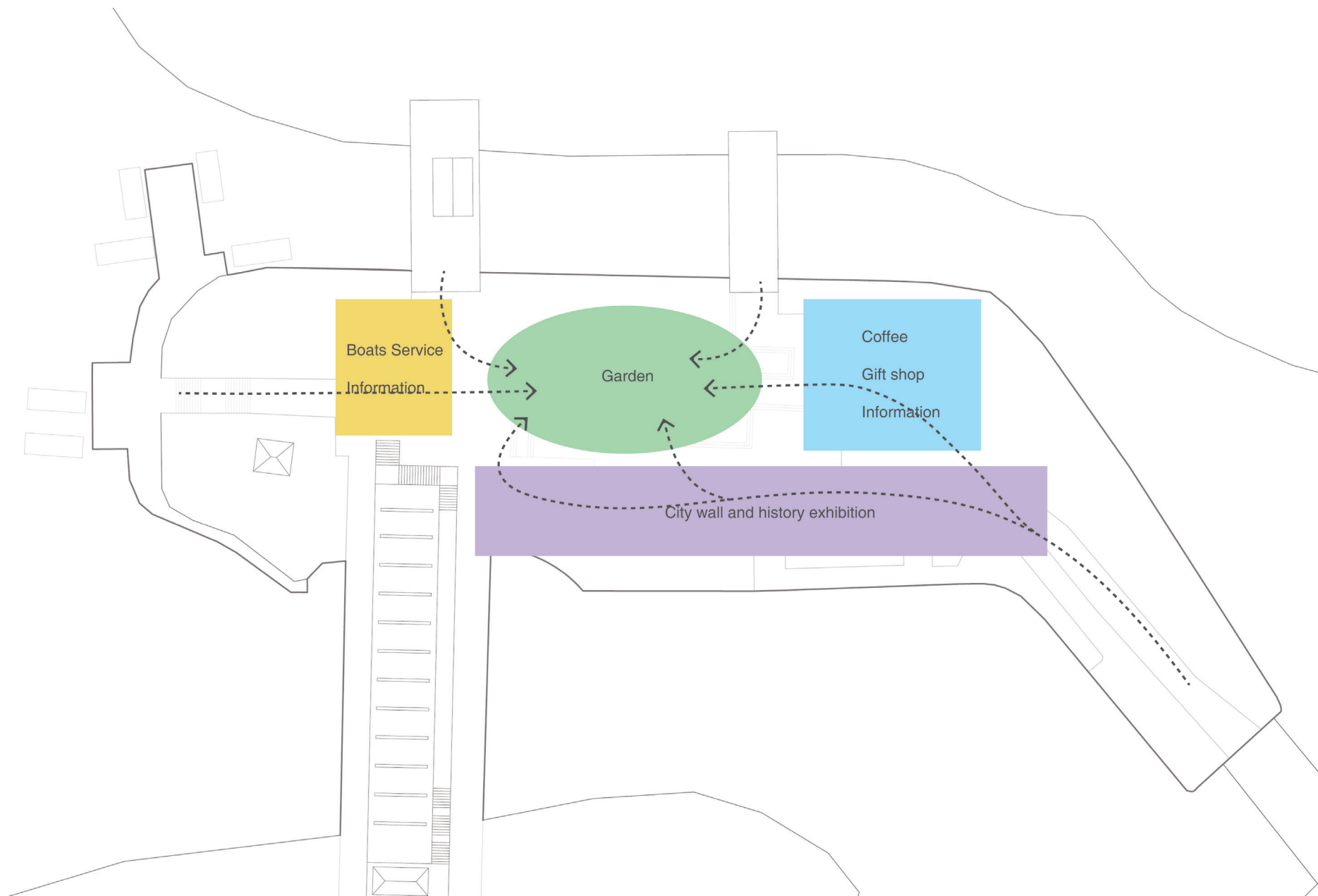

Function and circulation studies

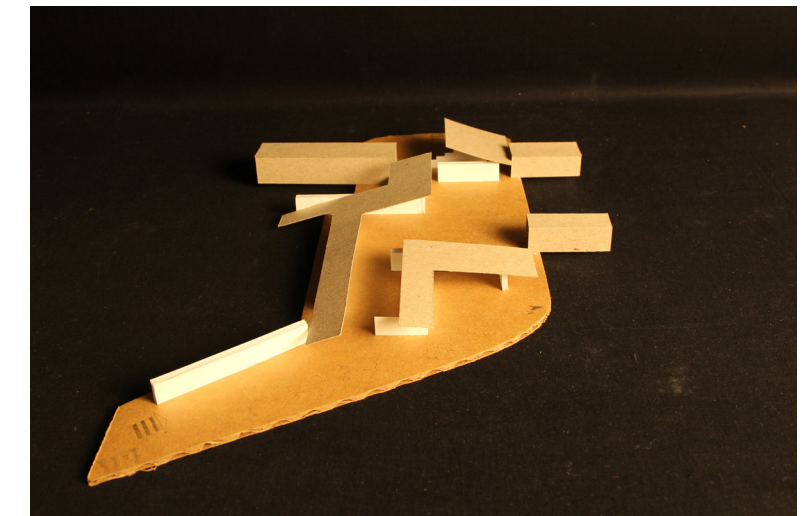
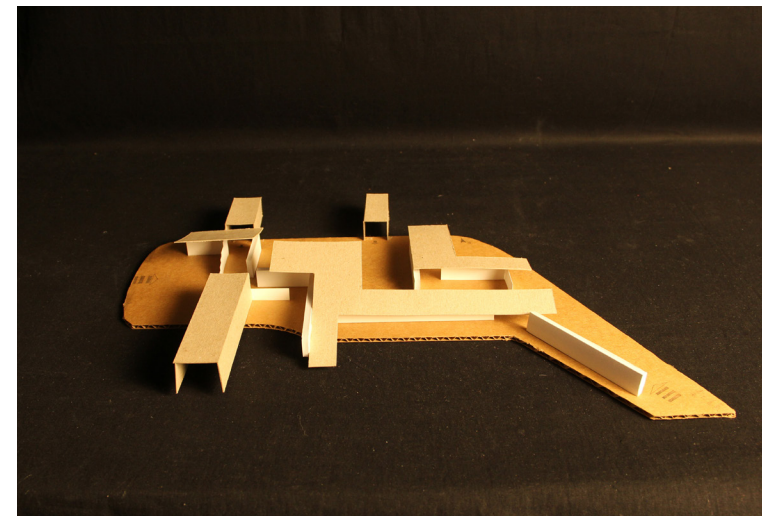
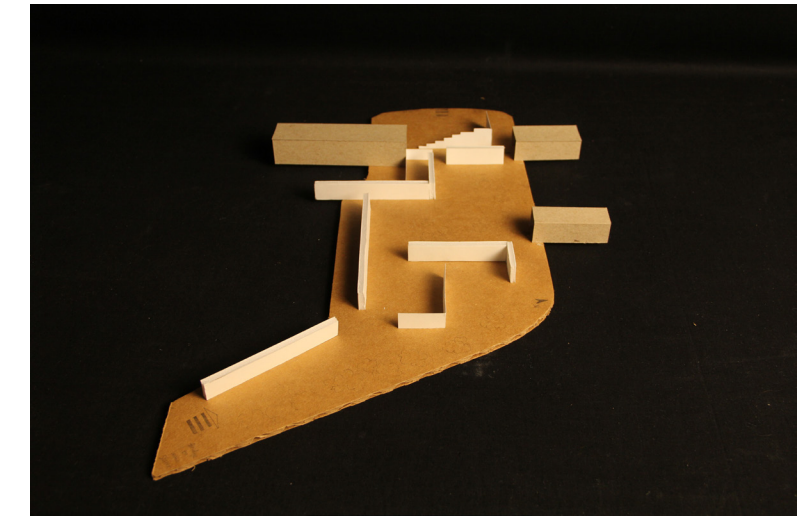
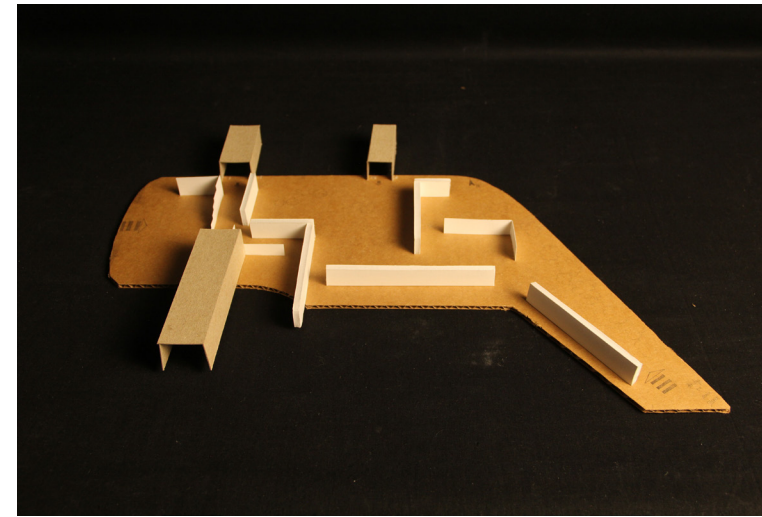

When I had the idea of function and circulation, I made models to study the placement of new walls. Besides, I found that roof forms had a significant influence on spatial feelings.

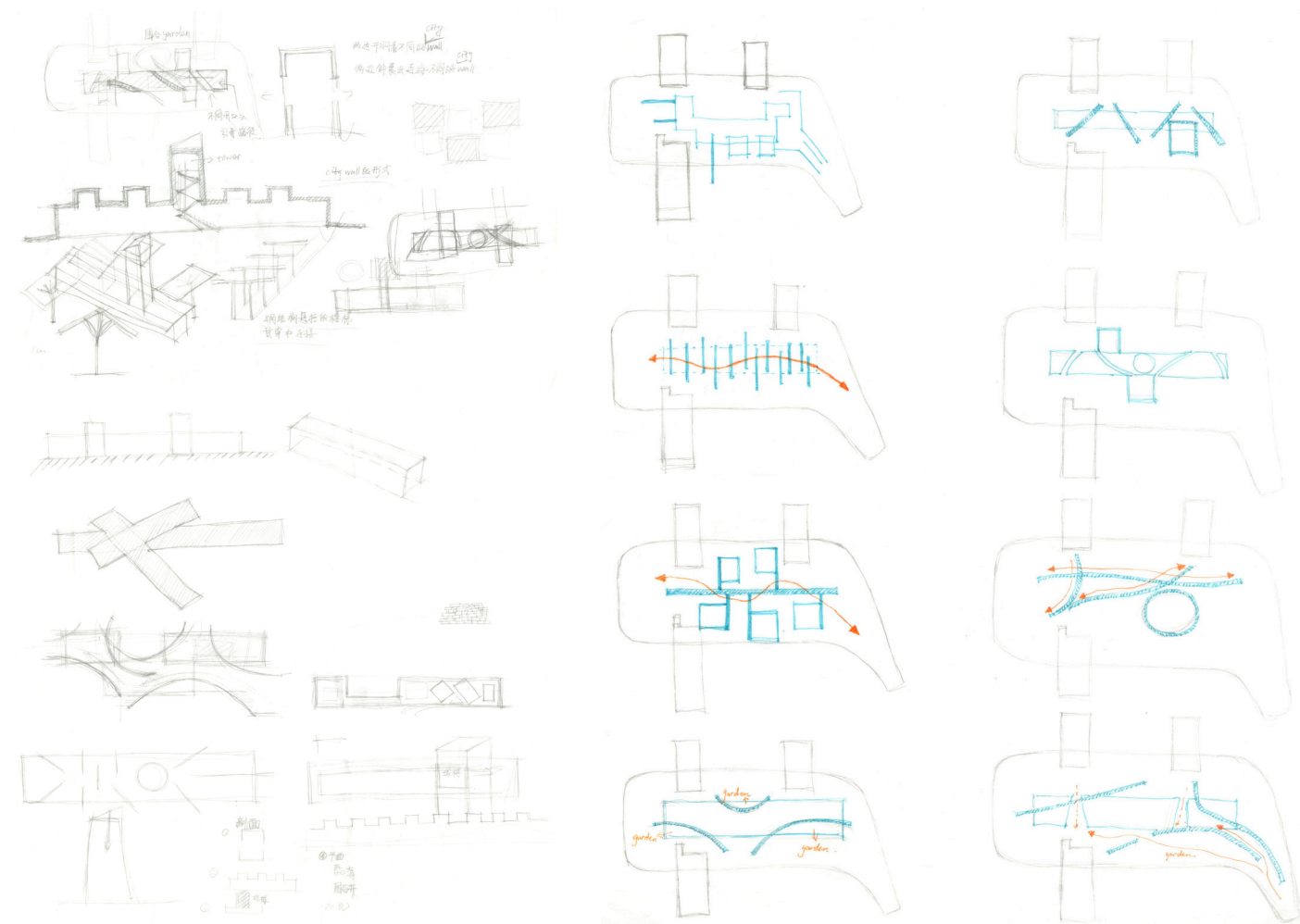

It was a long process for me to figure out the best solution of circulation and how to place new walls. I studied many possibilities and finally decided to use curved walls and diagonal walls.



Function studies and wall design studies. Curved walls and diagonal walls create a wall garden with two main indoor parts. A wall that extends to the river will be included as well.

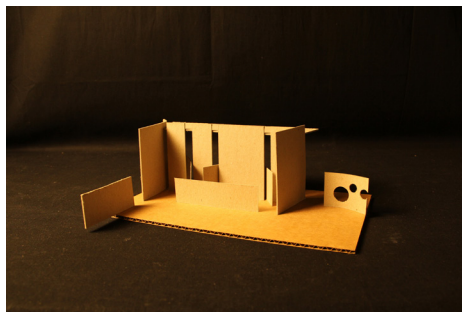
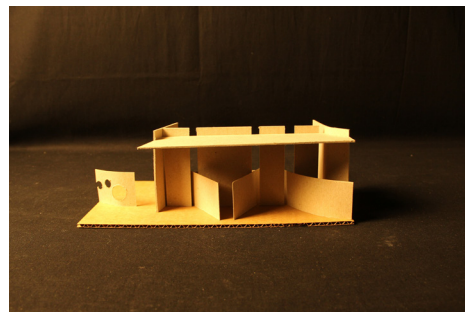
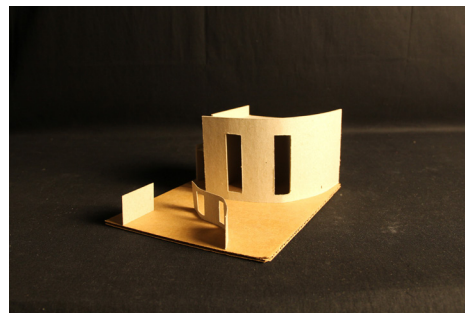

I made models to study walls and spaces. When curved walls, straight walls and diagonal walls are combined together, new spaces with beautiful light are created. Light has significant influence on people's feelings, which is an important part of my design strategies.

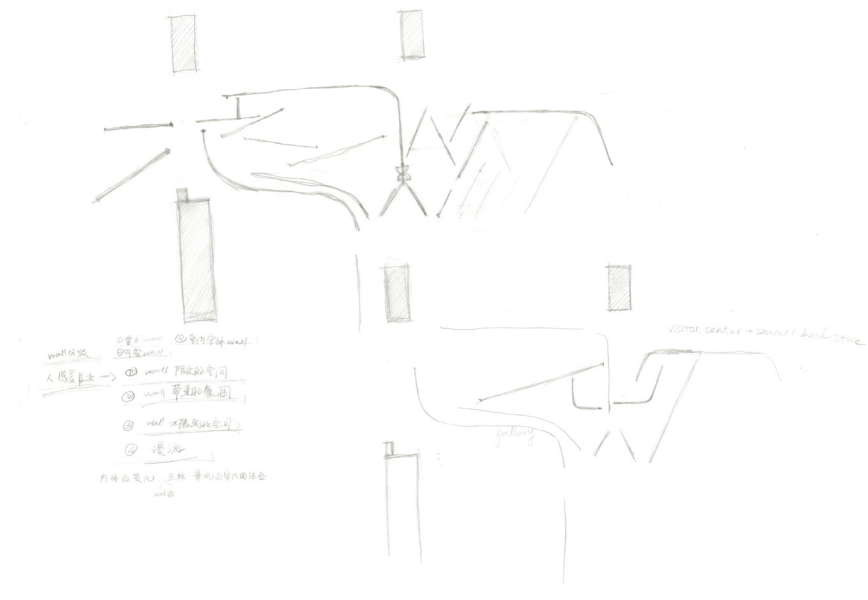

0号 → ① 到到到到到
0号 → ② 到到到到到
人居住区 → ③ 到到到到到
④ 到到到到到
⑤ 到到到到到
⑥ 到到到到到
⑦ 到到到到到
⑧ 到到到到到
⑨ 到到到到到
⑩ 到到到到到
⑪ 到到到到到
⑫ 到到到到到
⑬ 到到到到到
⑭ 到到到到到
⑮ 到到到到到
⑯ 到到到到到
⑰ 到到到到到
⑱ 到到到到到
⑲ 到到到到到
⑳ 到到到到到
㉑ 到到到到到
㉒ 到到到到到
㉓ 到到到到到
㉔ 到到到到到
㉕ 到到到到到
㉖ 到到到到到
㉗ 到到到到到
㉘ 到到到到到
㉙ 到到到到到
㉚ 到到到到到
㉛ 到到到到到
㉜ 到到到到到
㉝ 到到到到到
㉞ 到到到到到
㉟ 到到到到到
㊱ 到到到到到
㊲ 到到到到到
㊳ 到到到到到
㊴ 到到到到到
㊵ 到到到到到
㊶ 到到到到到
㊷ 到到到到到
㊸ 到到到到到
㊹ 到到到到到
㊺ 到到到到到

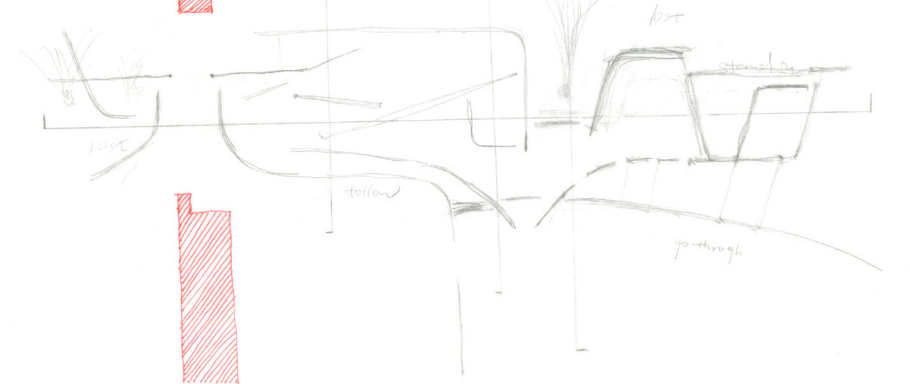
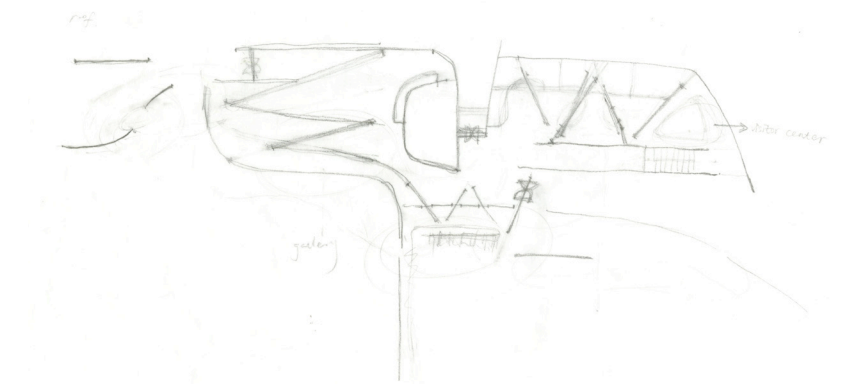

Plan studies

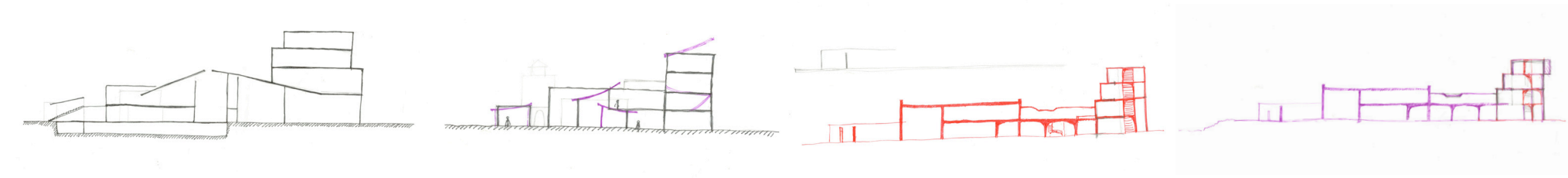

Section studies

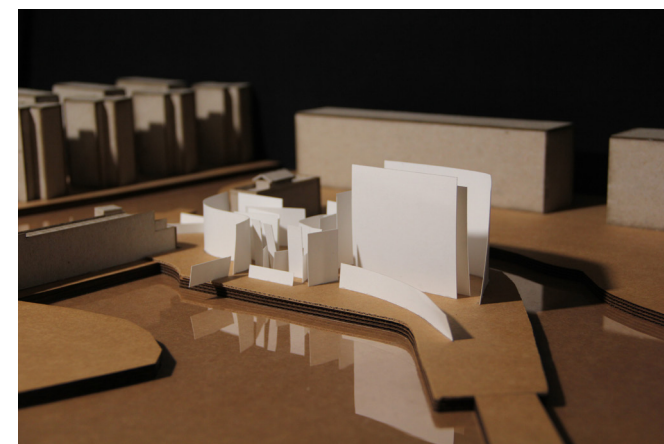
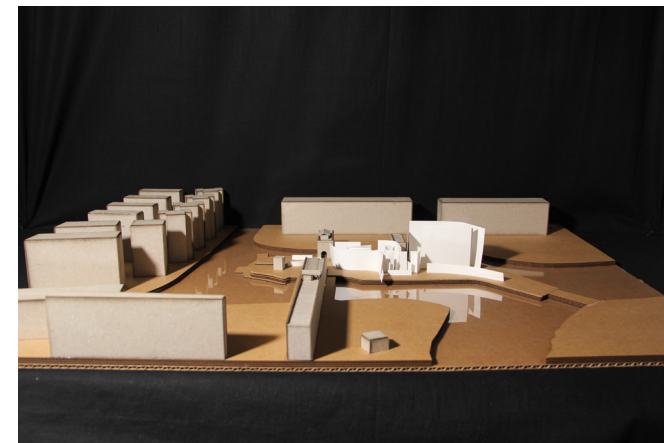
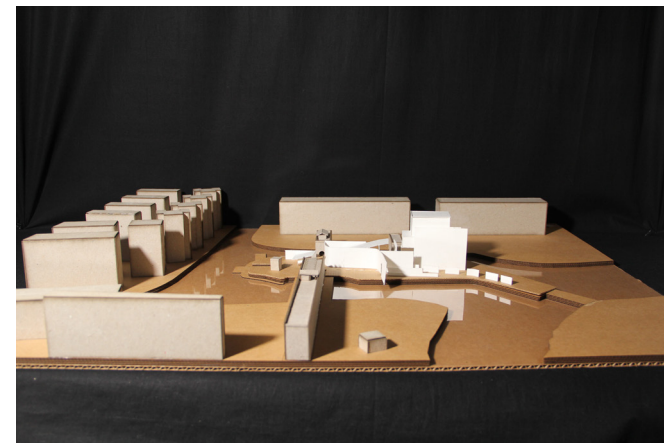
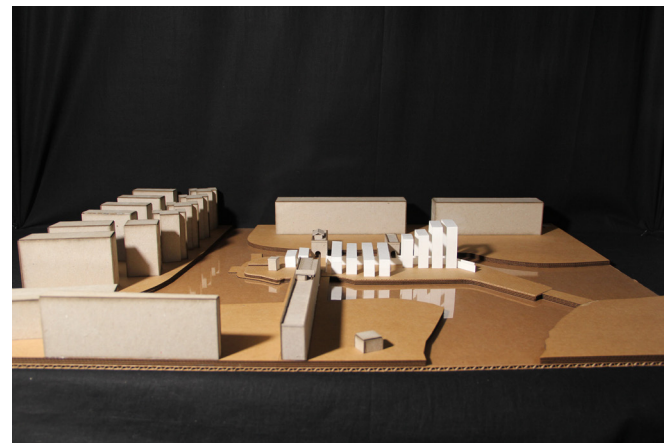

Circulation and form study 01

Circulation studies. A main path goes through these new walls to connect all functions together.

Circulation and form study 02

Circulation studies. Place new walls along the edge of the island to create a path surrounding the main functions.

Circulation and form study 03

Form studies. Use discontinuous walls as an attraction at the entrance. Design balconies on each floor of the tower. Try sloping roof in exhibition space.

Circulation and form study 04

Form studies. Use different curved walls to create spaces and free circulation.

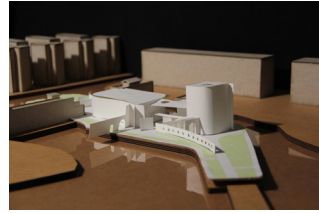

Scheme 01 in form study

After circulation and form studies, I came up with a more complete design. I used arches as an attraction at the entrance. Also a roof was designed for the garden in the center. The roof of the exhibition space was designed as a flat roof with skylights.

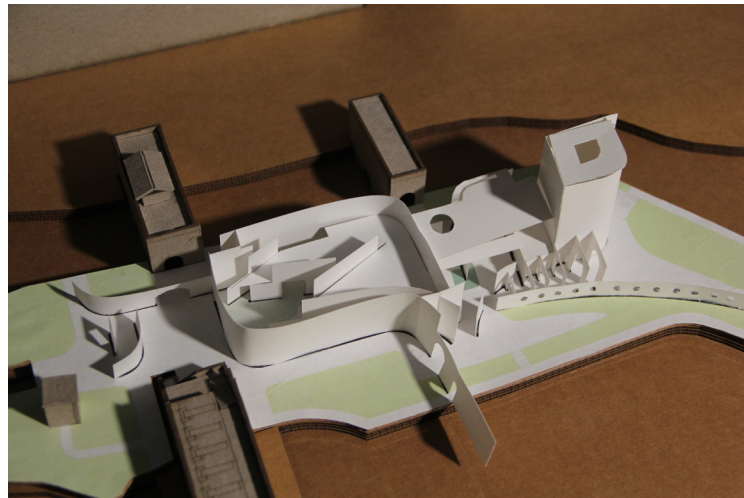
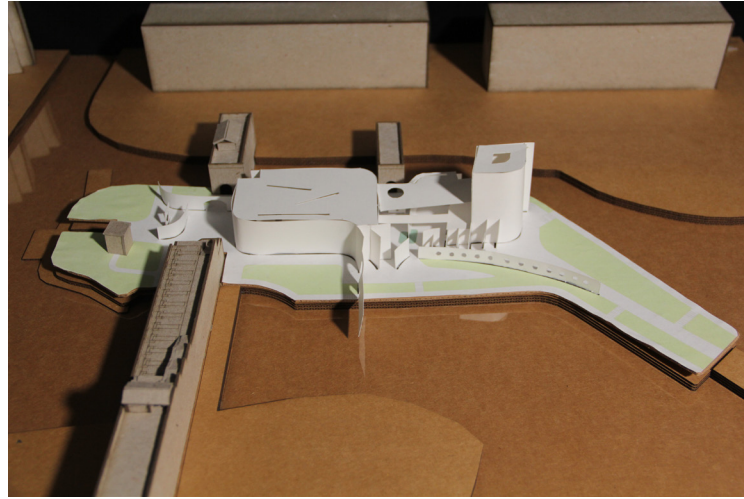
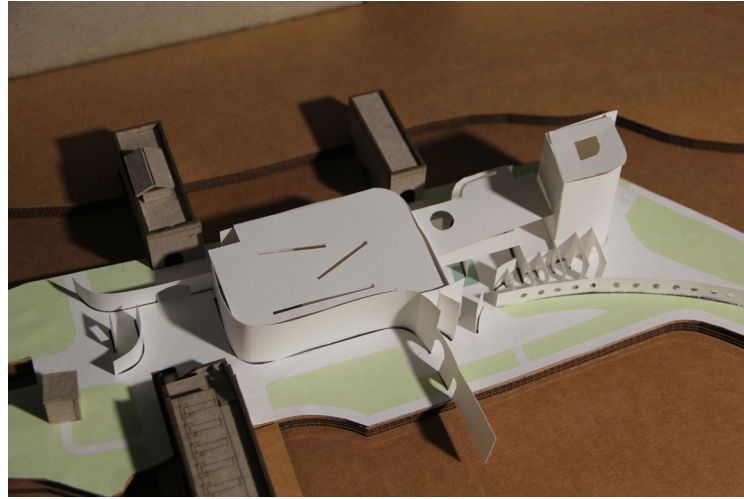

Scheme 02 in form study

After scheme 01, I redesigned the roof of the exhibition space and thought about elevation design. The shape of the roof for the central garden was changed as well, for creating a space to store water. The waterfall from this roof was another kind of wall experience for people who walked on the bridge over the garden.

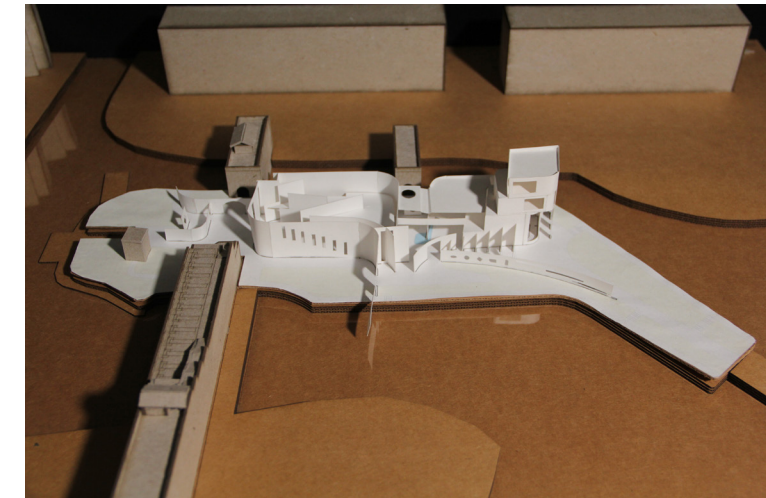
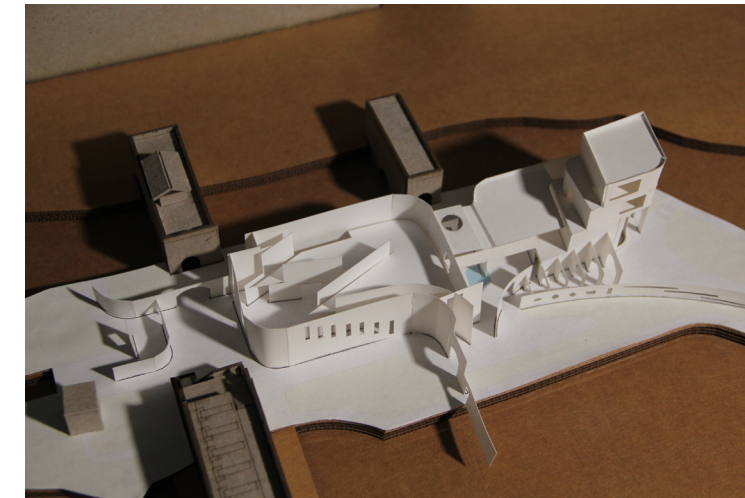
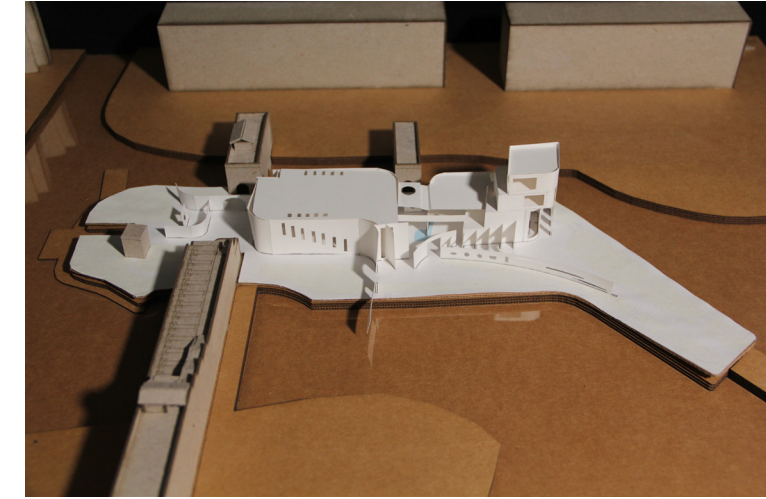
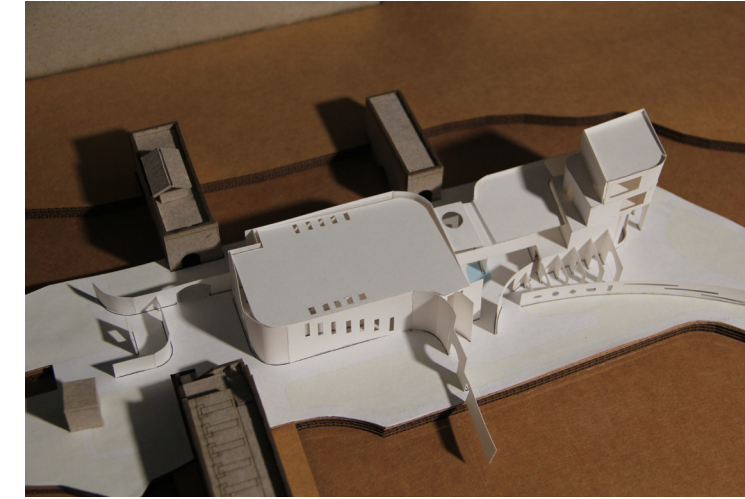

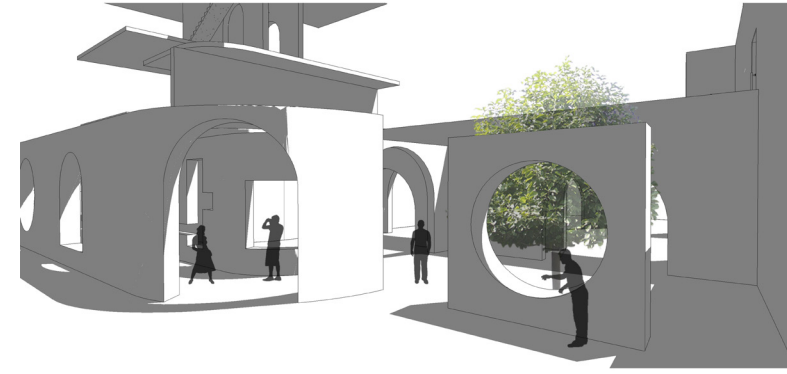
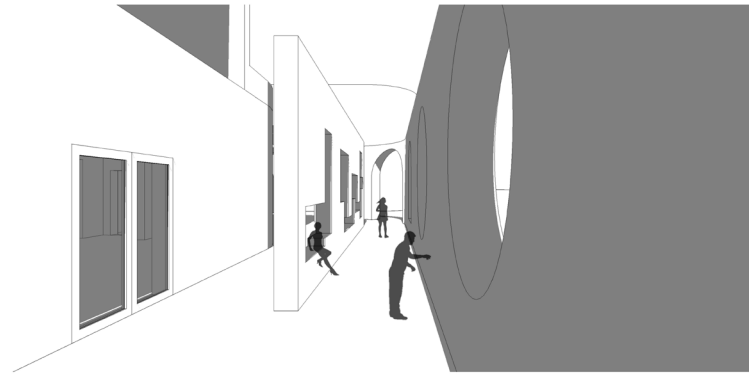
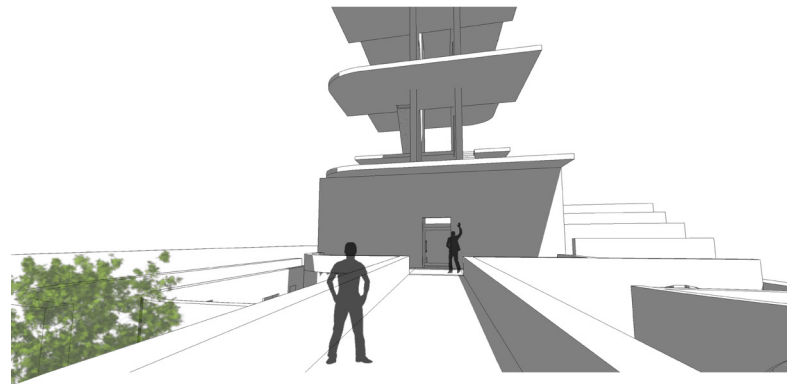

New walls will form several different small spaces with unique feelings. In these spaces, people get the chance to interact with walls and plants. These small places are very important elements in my wall design, which will give me the direction to improve space feelings. How to place these walls and the forms of openings are two significant methods. I tried to use round and square openings in these walls as they are traditional elements in Chinese gardens. Arches are used as well, which is a dialogue between the city wall and the new walls.

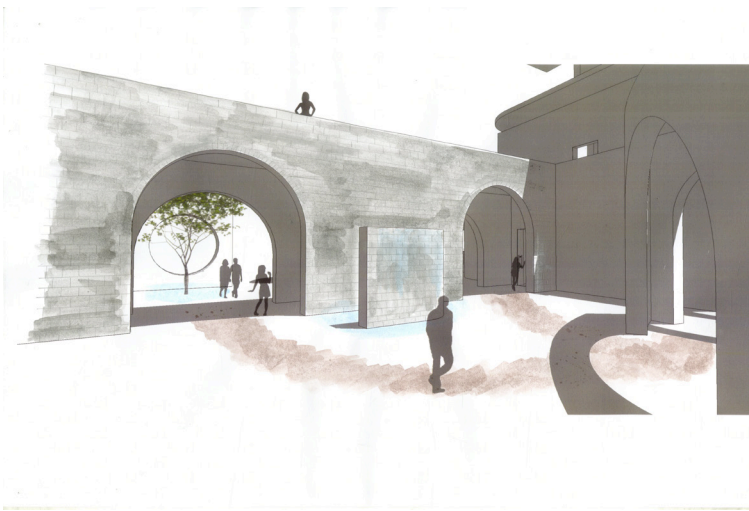
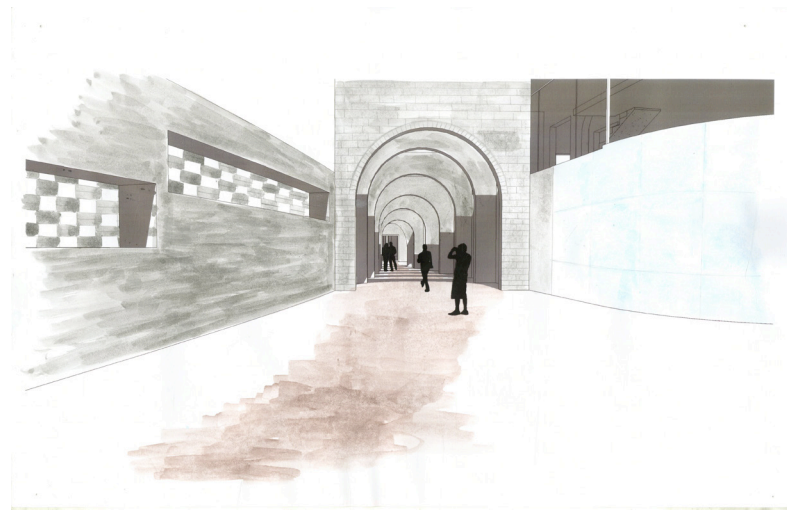

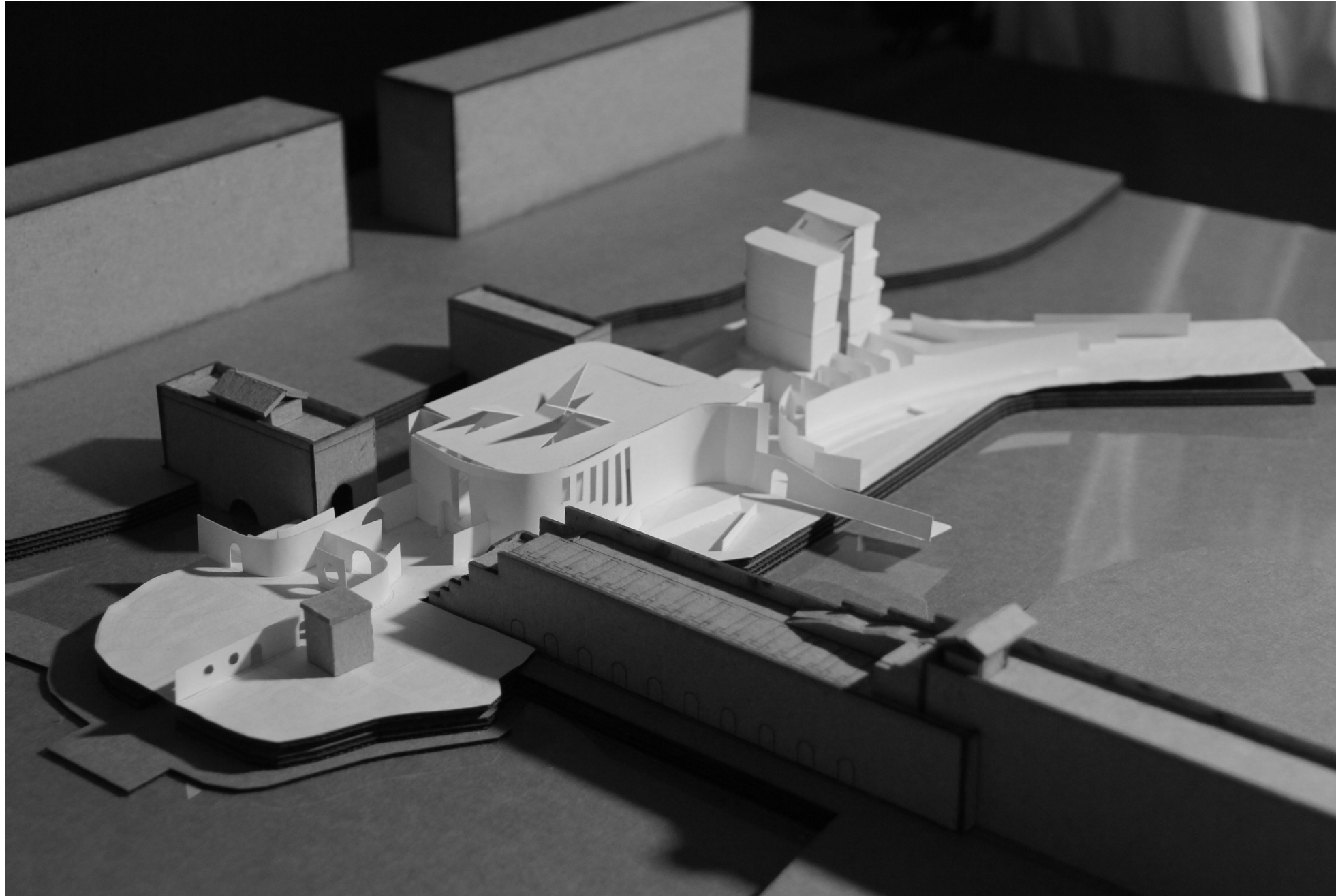

Final scheme model

Final Scheme

Final scheme comes with well-designed plans, sections, details and landscapes. It represents my idea of creating various possibilities in a wall garden. With plan drawings, section drawings, charcoal drawings, details and perspectives, a completed wall garden will gradually present itself in front of people who come to this island and wander in it.

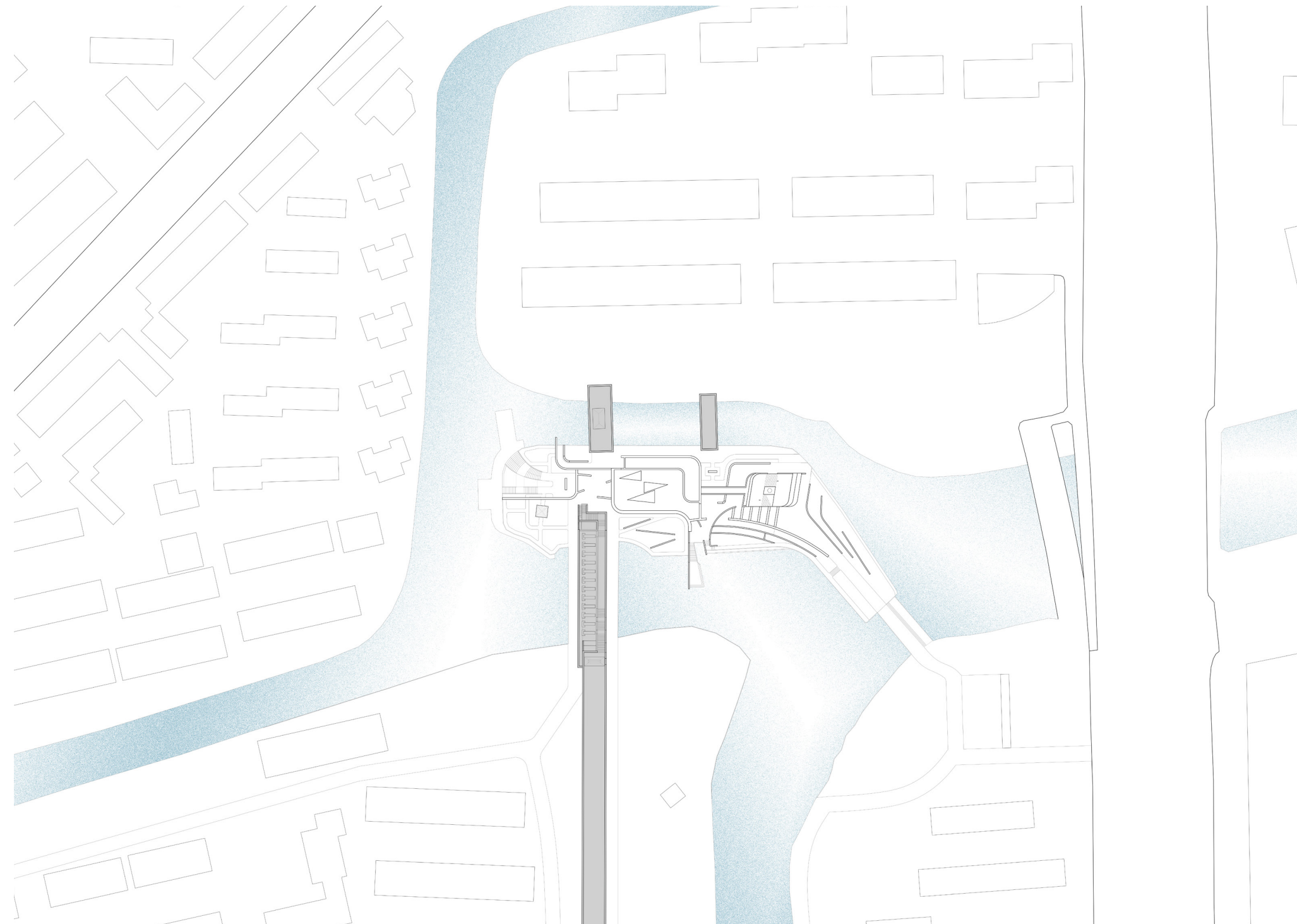

Site plan

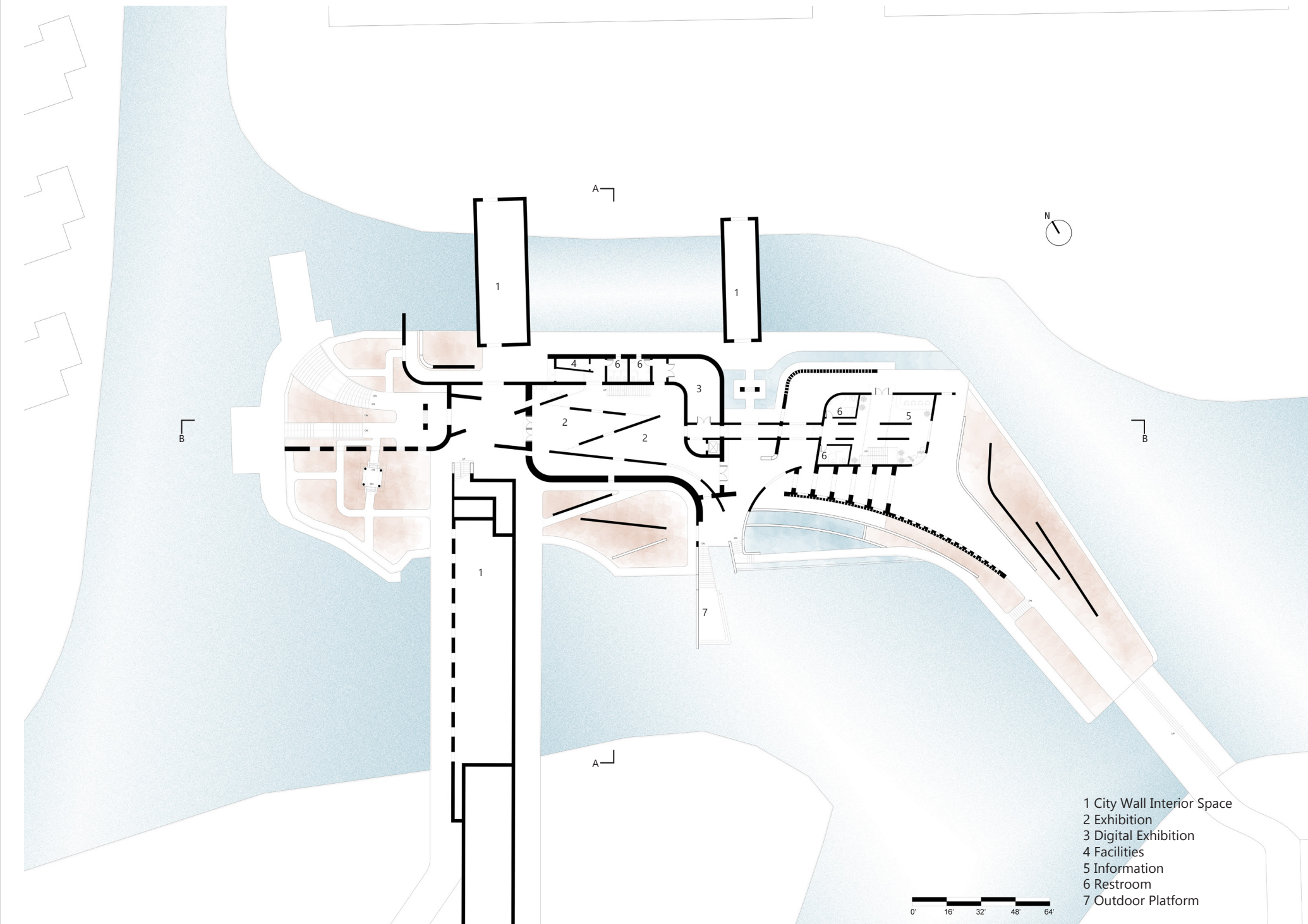

- 1 City Wall Interior Space
- 2 Exhibition
- 3 Digital Exhibition
- 4 Facilities
- 5 Information
- 6 Restroom
- 7 Outdoor Platform

First floor plan

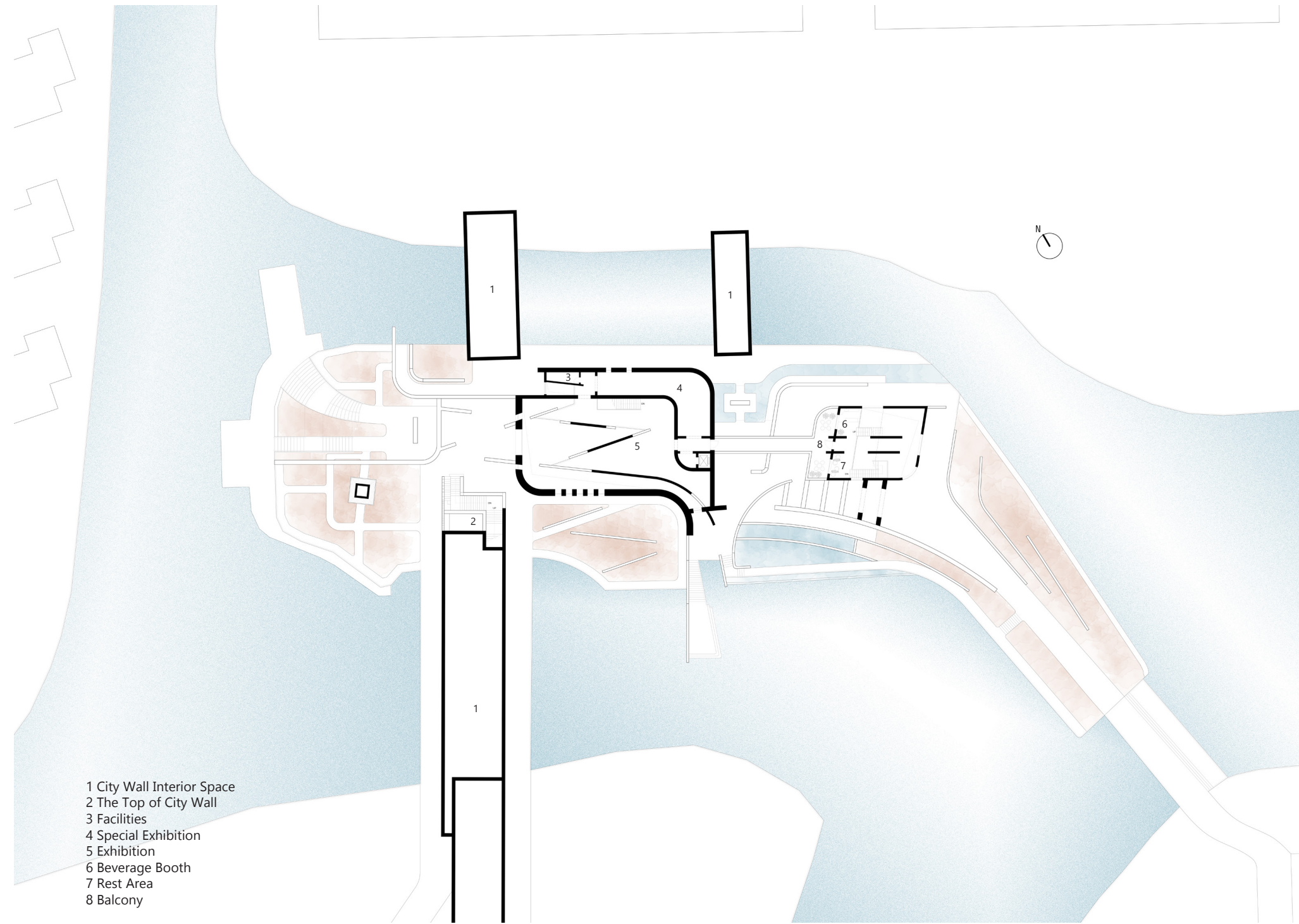

- 1 City Wall Interior Space
- 2 The Top of City Wall
- 3 Facilities
- 4 Special Exhibition
- 5 Exhibition
- 6 Beverage Booth
- 7 Rest Area
- 8 Balcony

Second floor plan

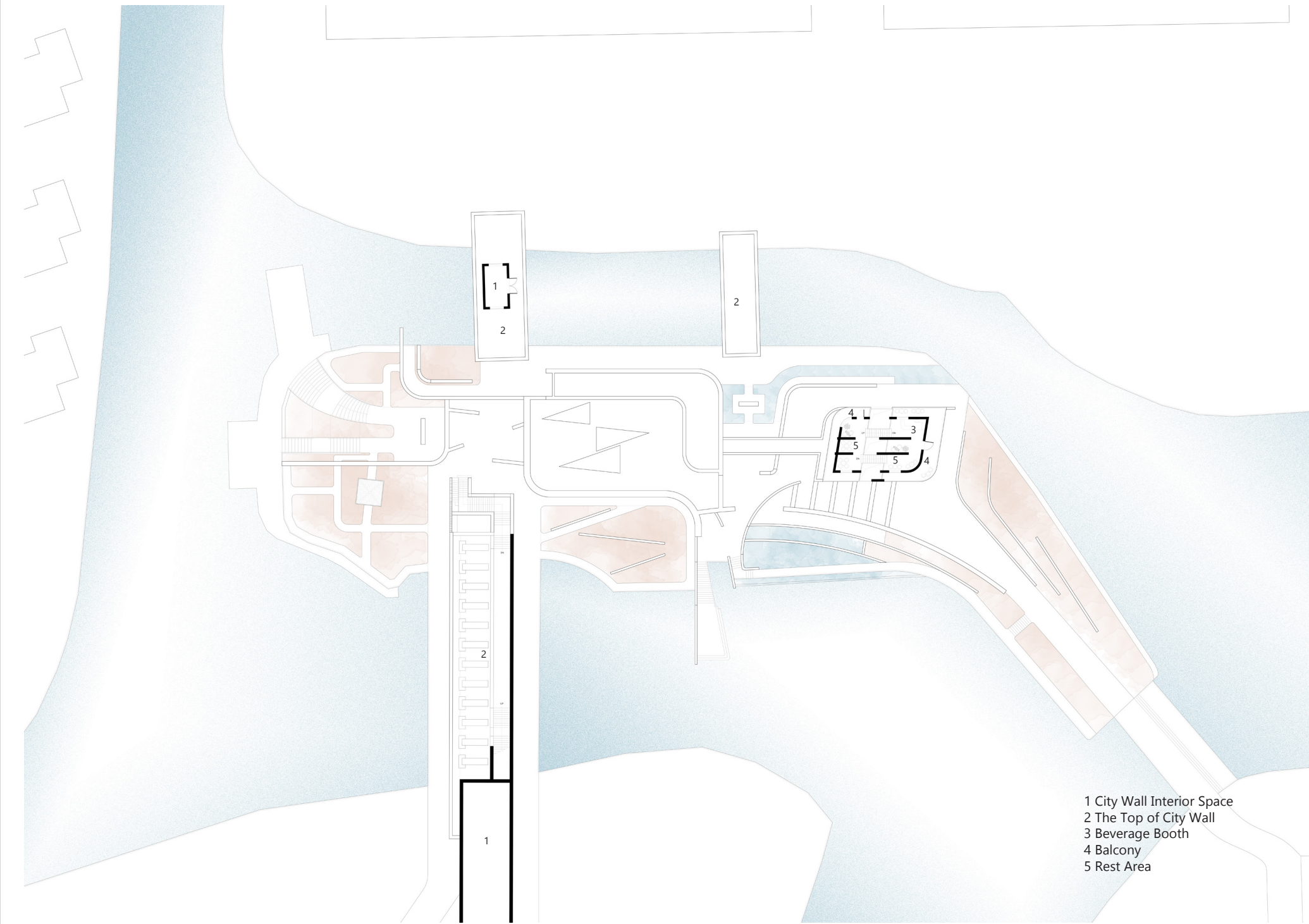

- 1 City Wall Interior Space
- 2 The Top of City Wall
- 3 Beverage Booth
- 4 Balcony
- 5 Rest Area

Third floor plan

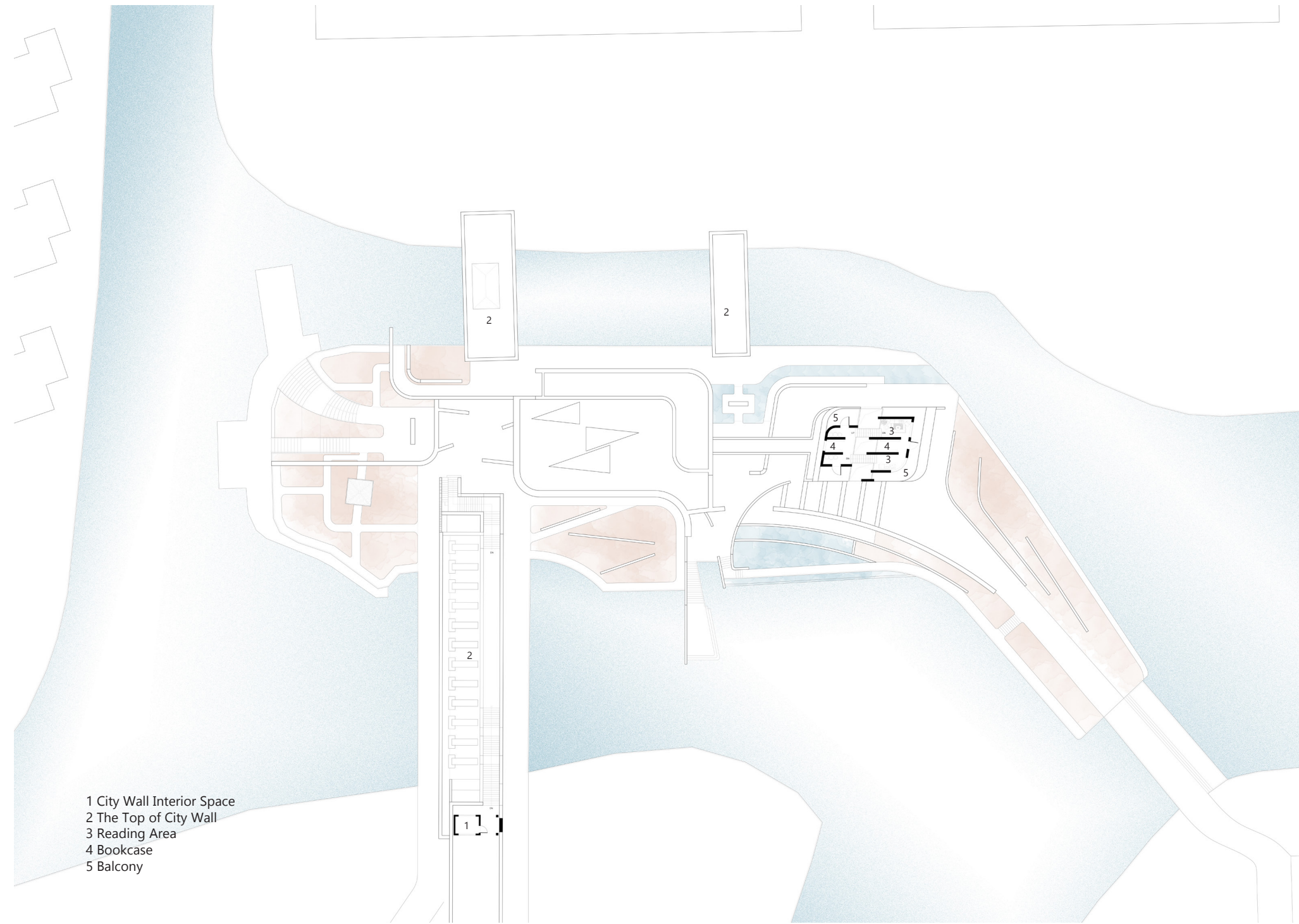

- 1 City Wall Interior Space
- 2 The Top of City Wall
- 3 Reading Area
- 4 Bookcase
- 5 Balcony

Fourth floor plan

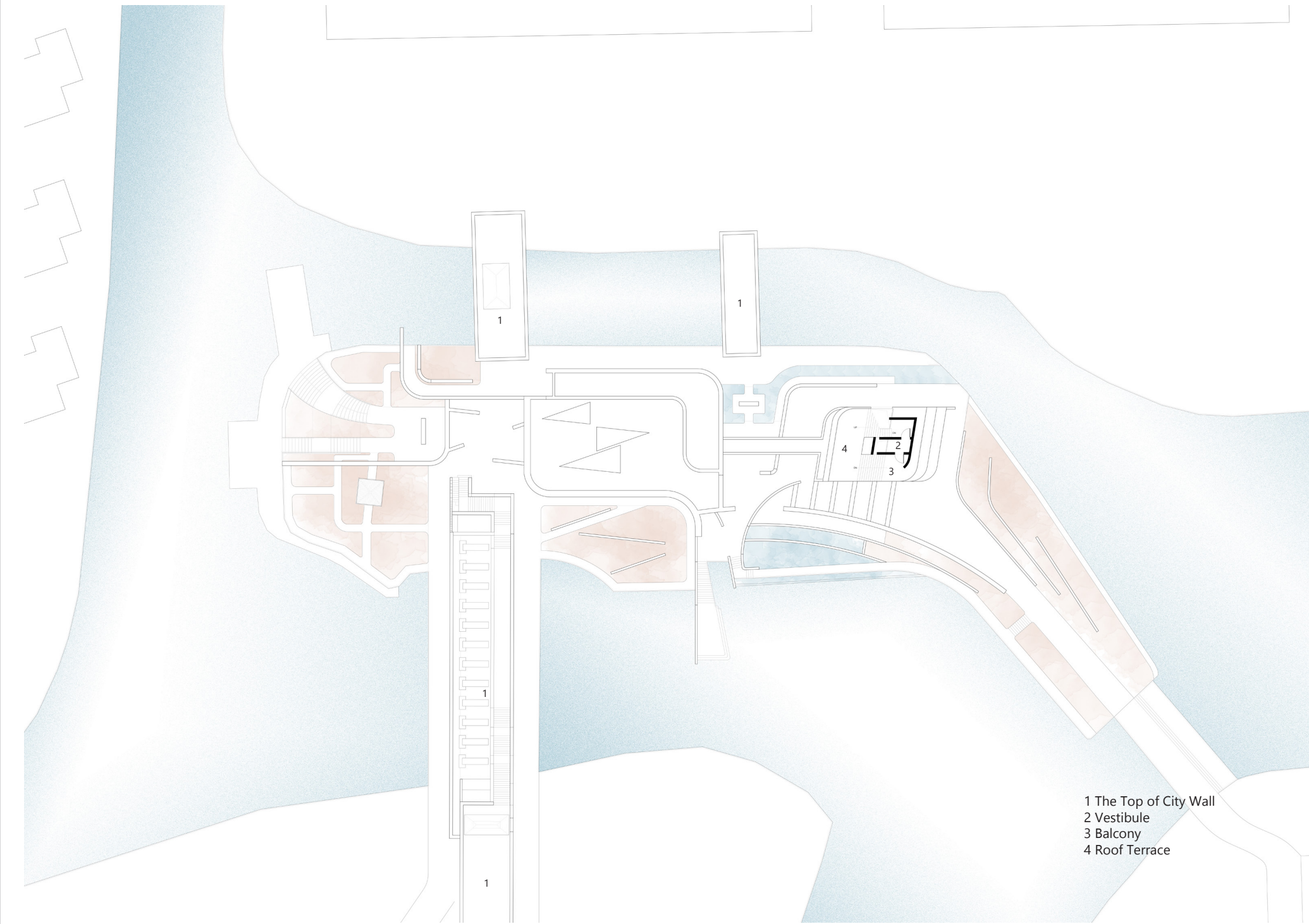

- 1 The Top of City Wall
- 2 Vestibule
- 3 Balcony
- 4 Roof Terrace

Fifth floor plan

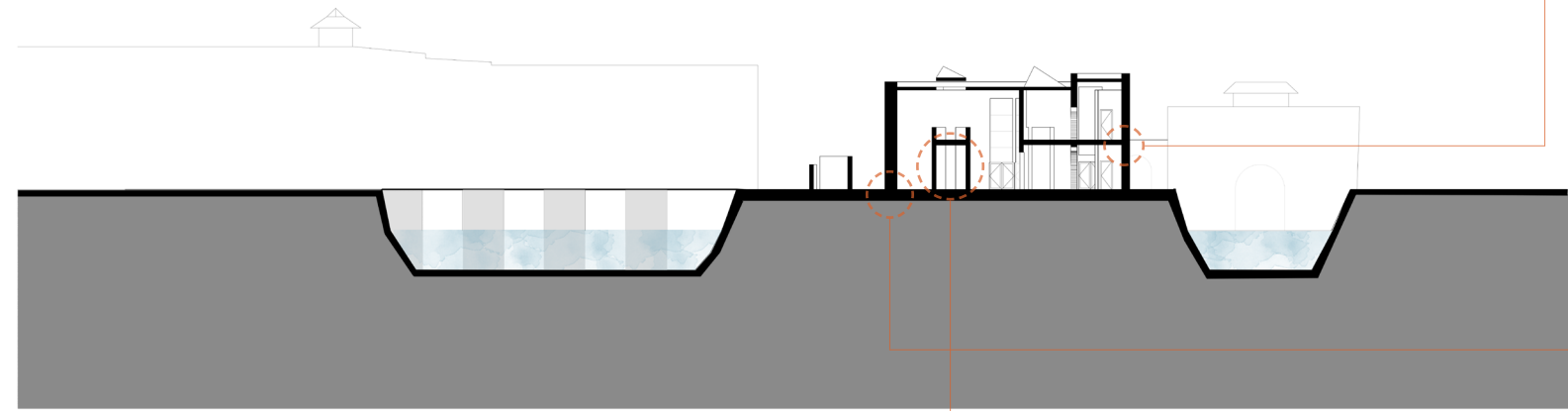

A-A Section

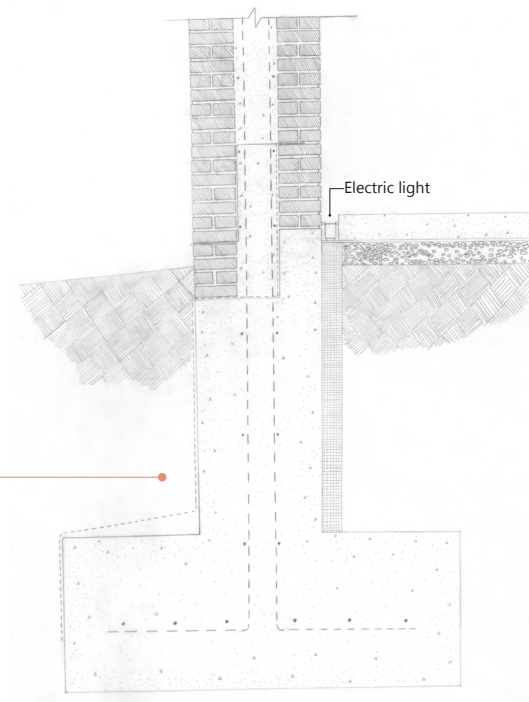

Foundation detail

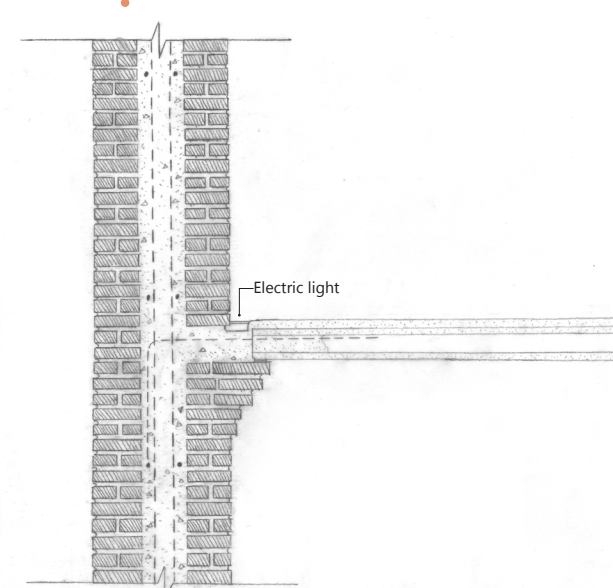

Wall and floor detail

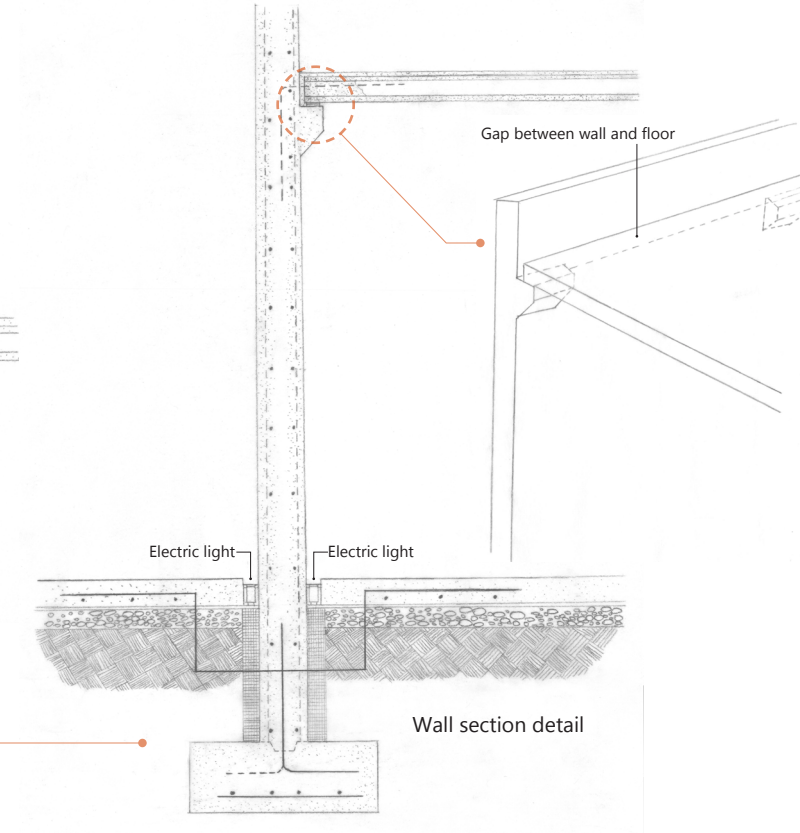

Wall section detail

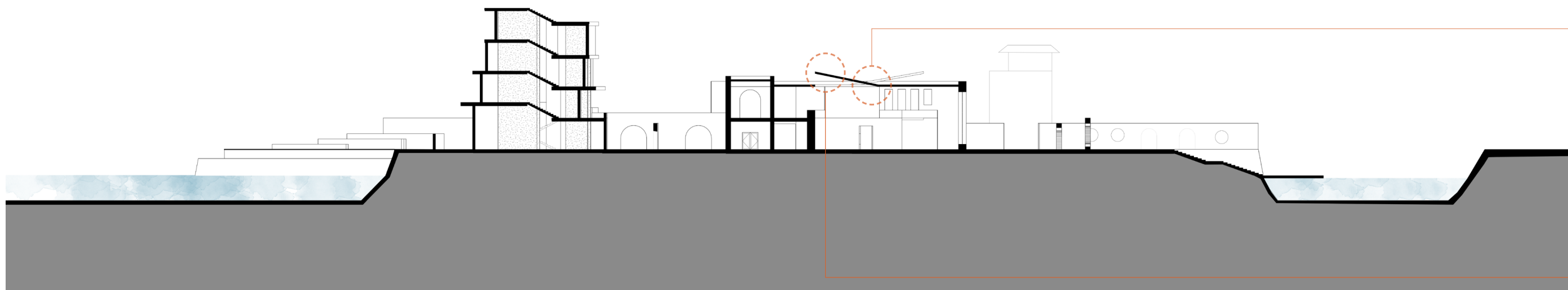

B-B Section

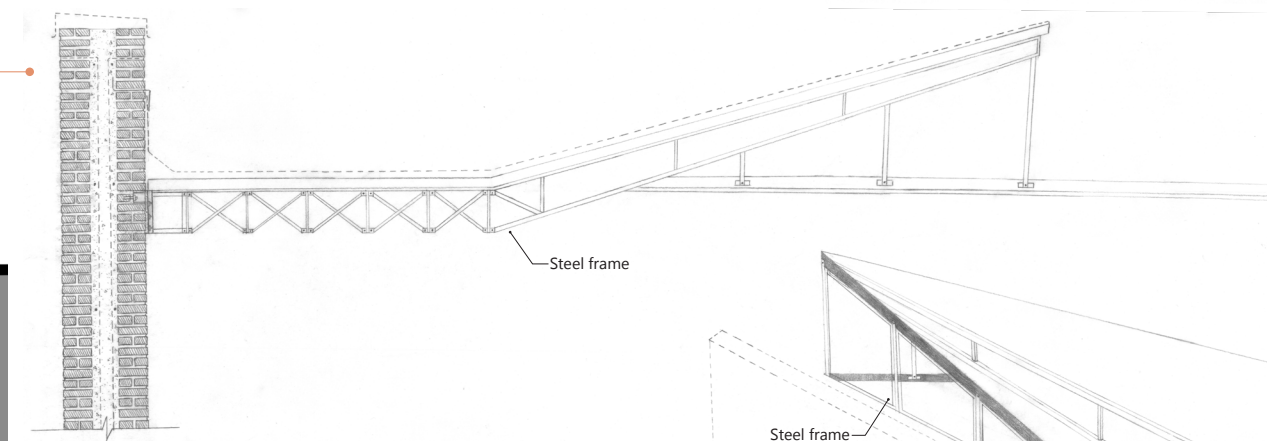

Roof detail (interior)

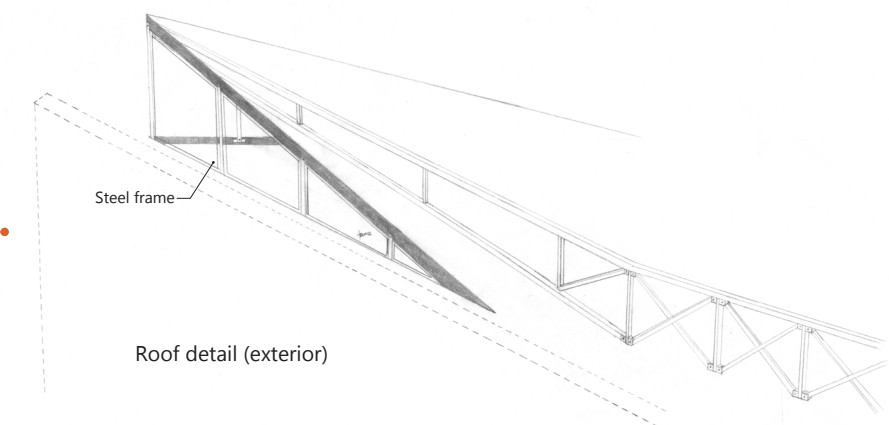

Roof detail (exterior)

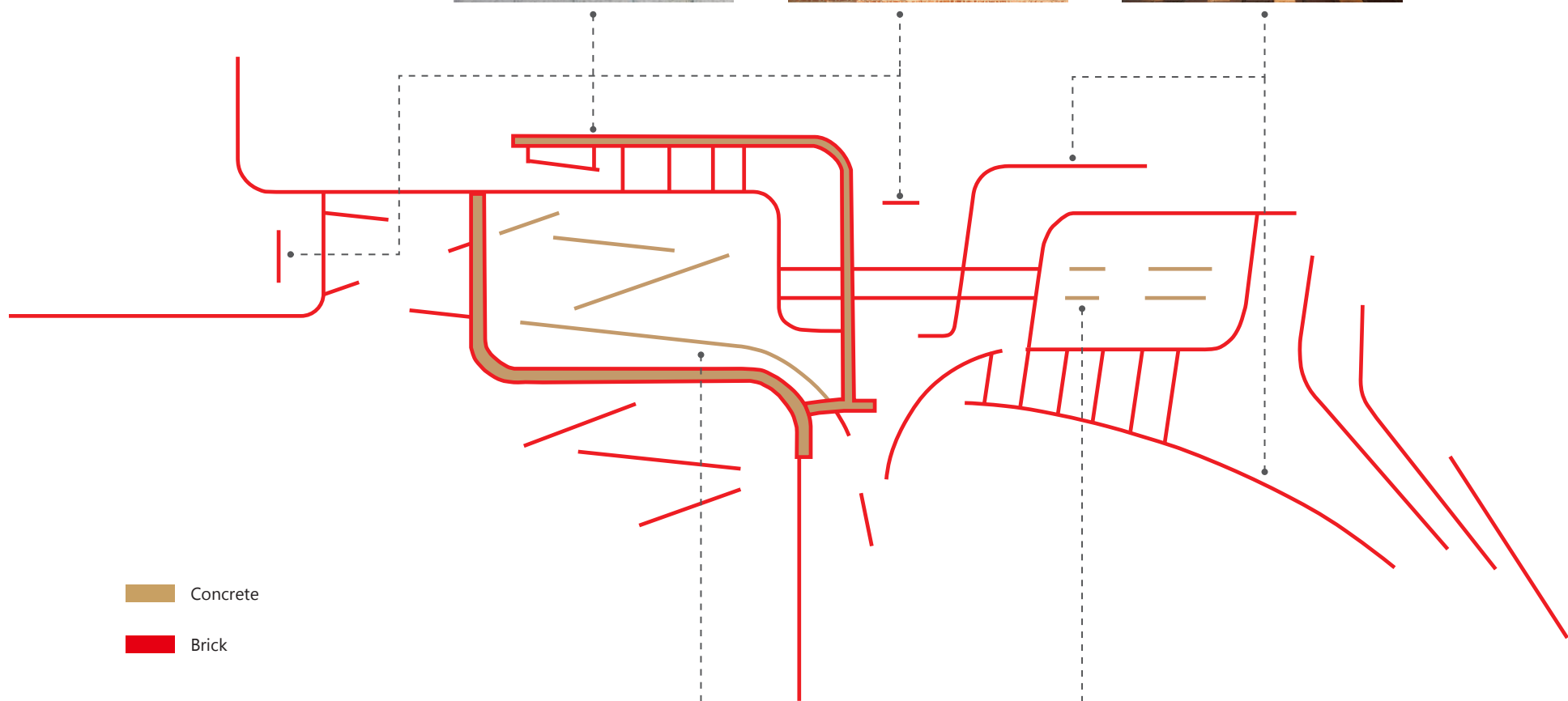

Concrete
Brick

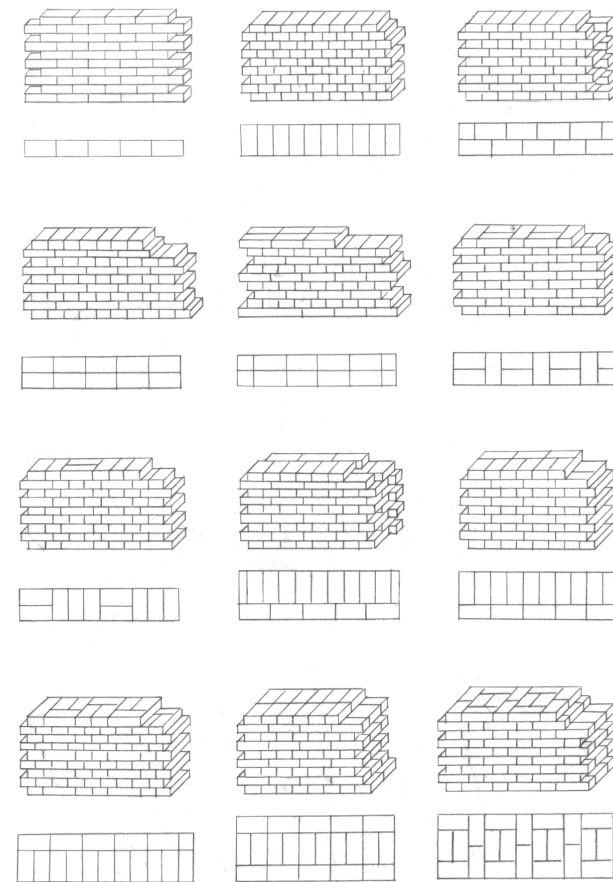
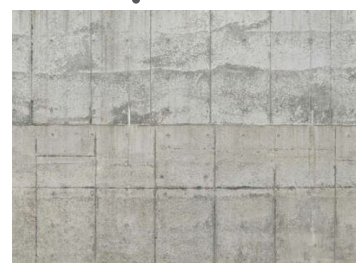

Brick wall study 01

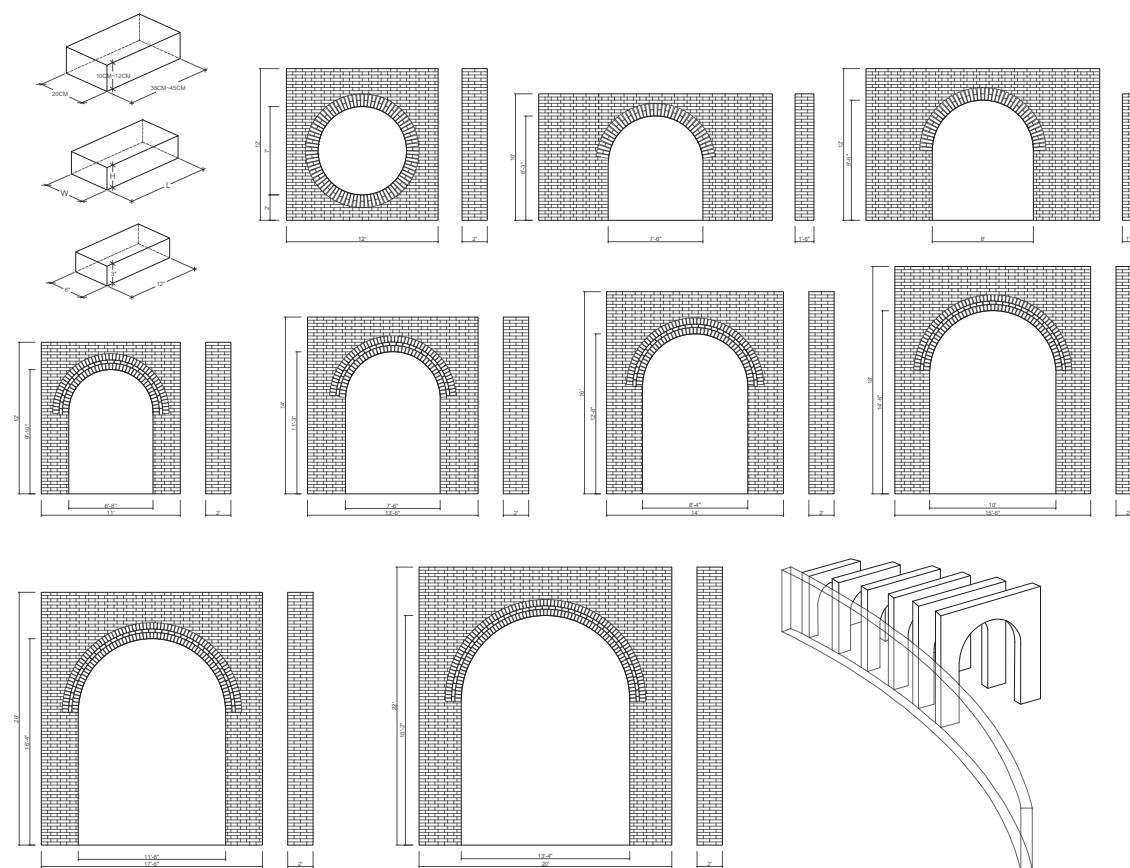

Brick walls in this design

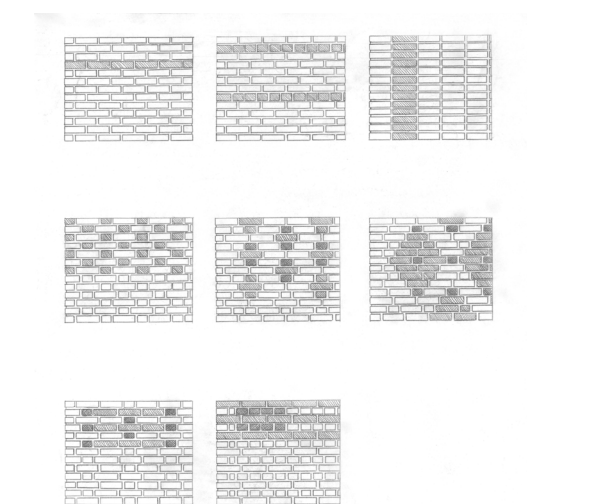

Brick wall study 02

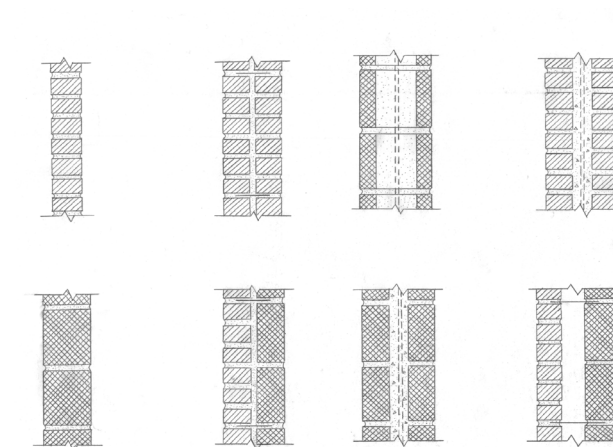

Brick wall study 03

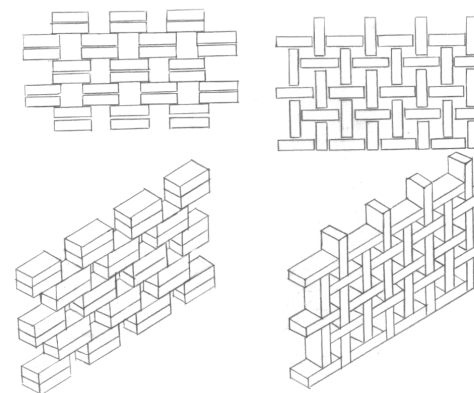

Brick wall study 04

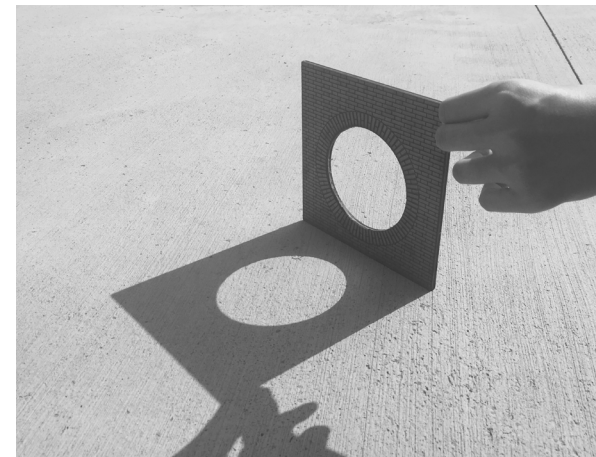
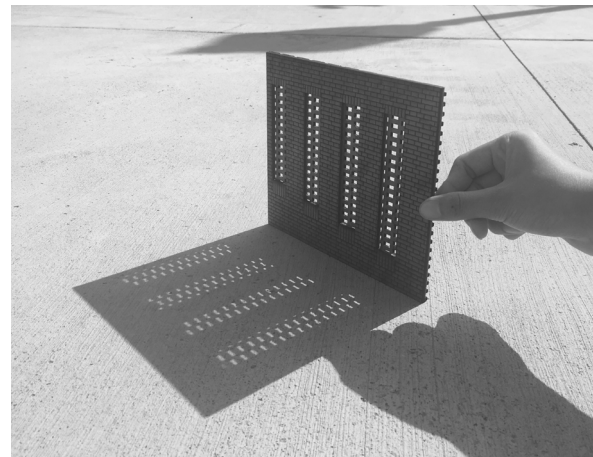
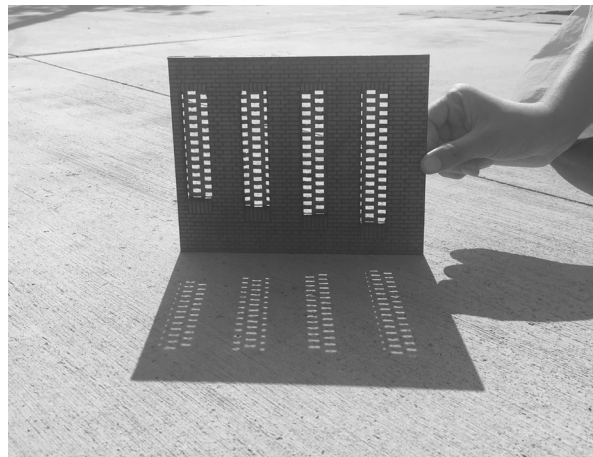
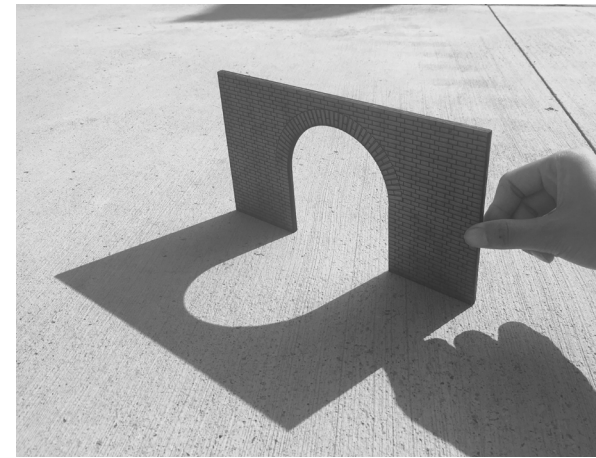
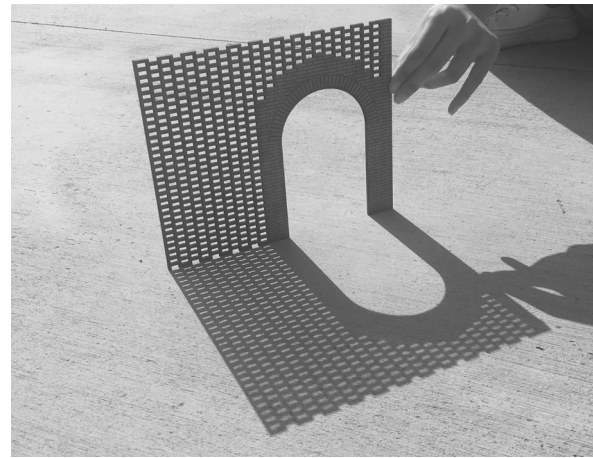
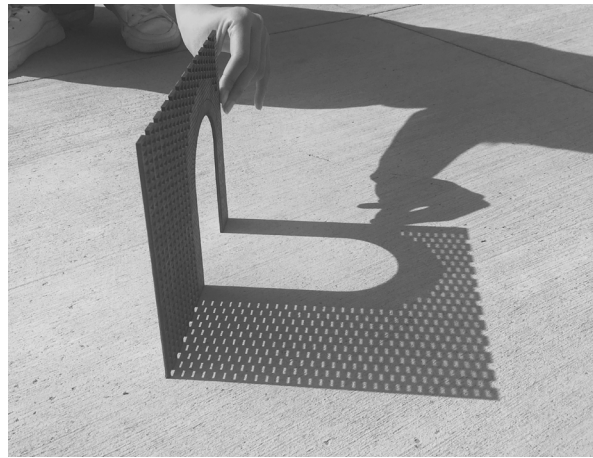

Brick wall models

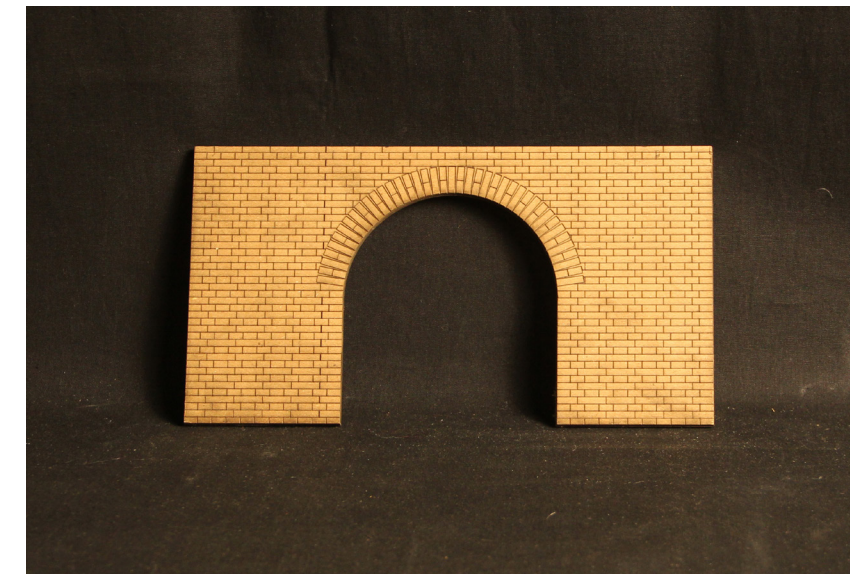
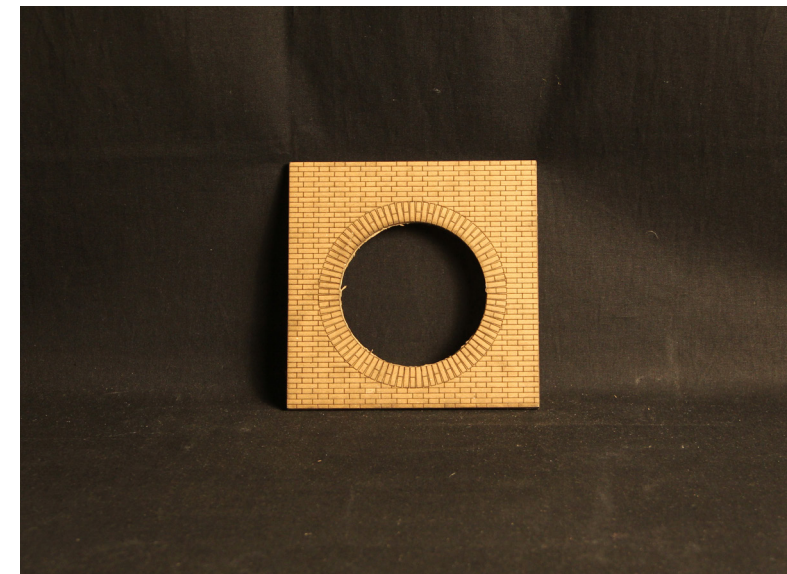
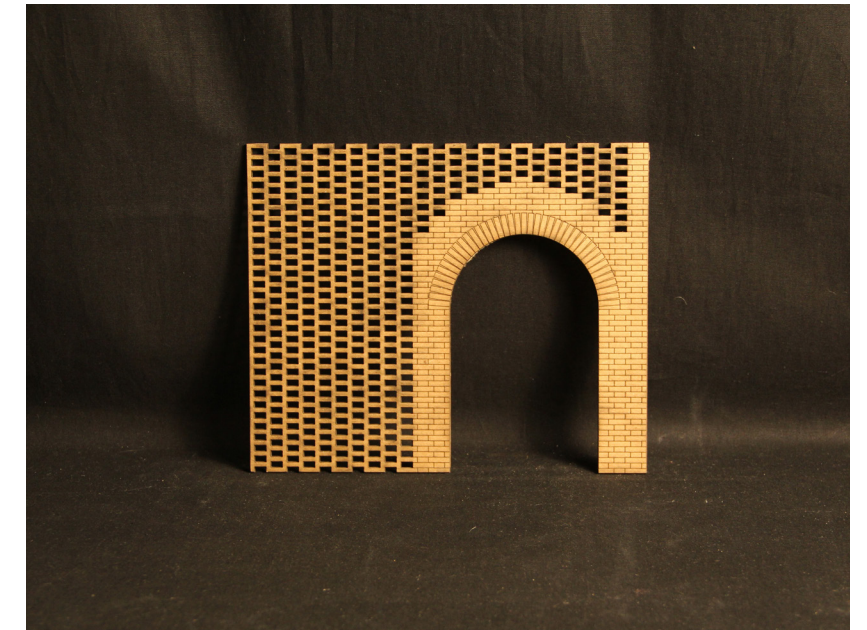
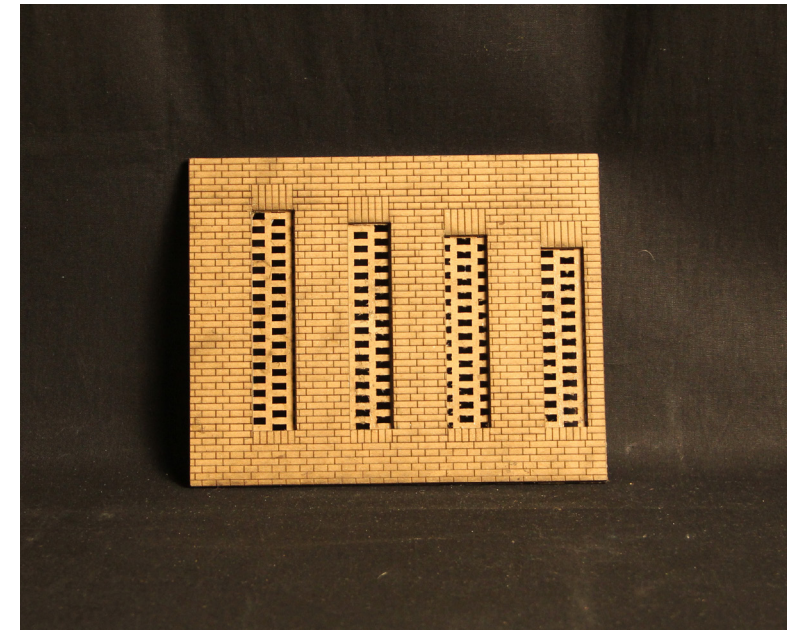

Brick wall models

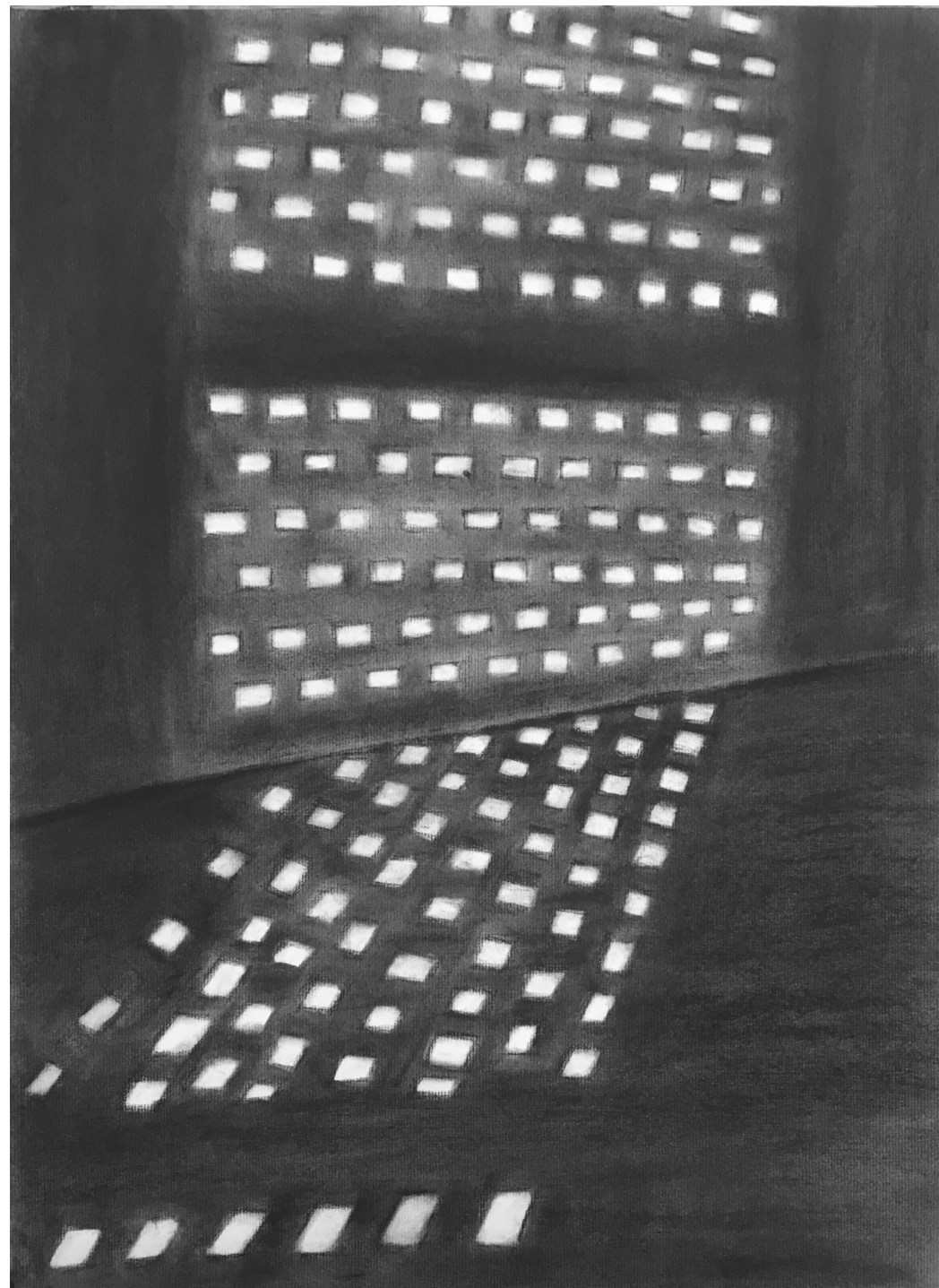

1

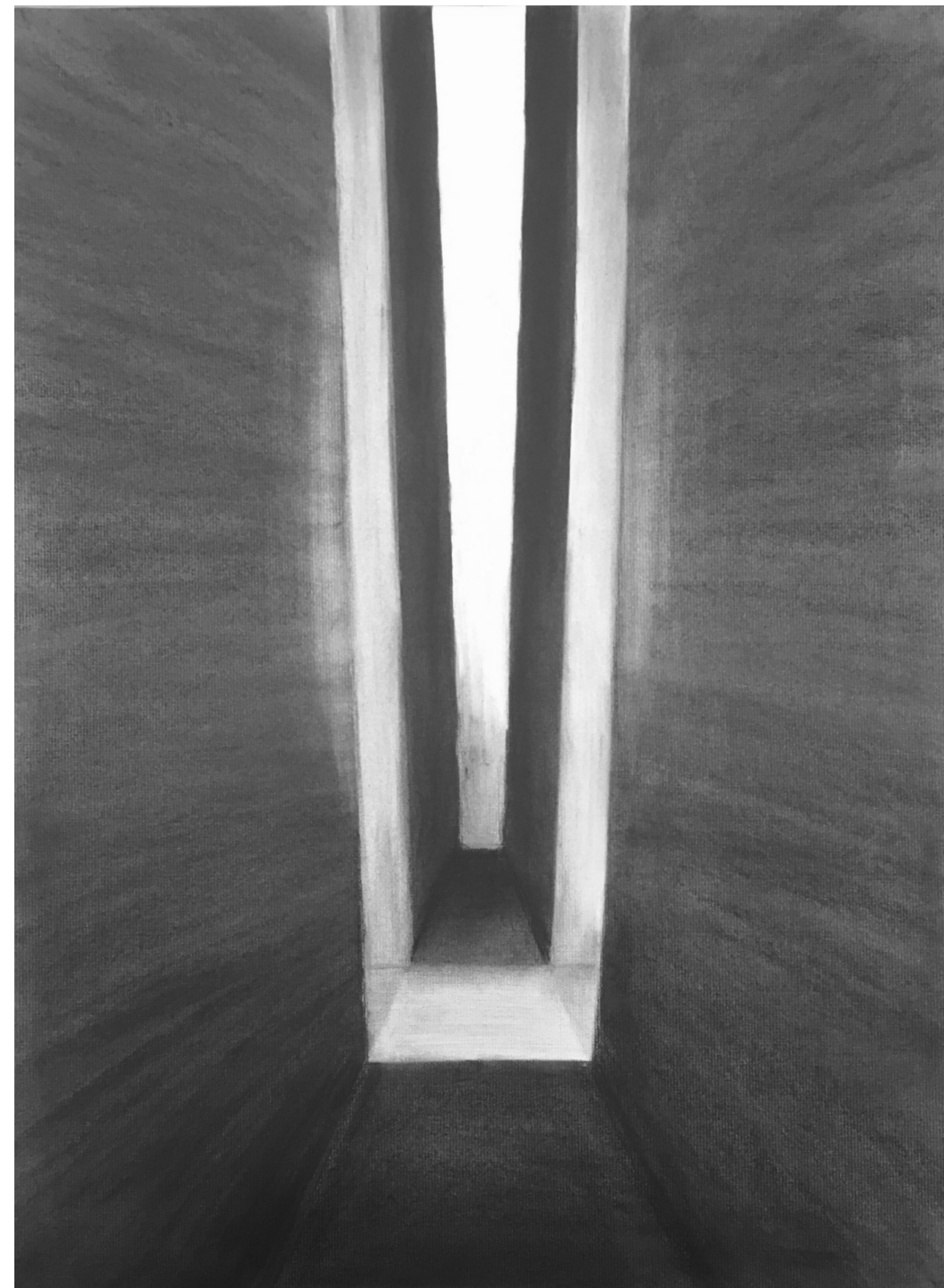

2



3

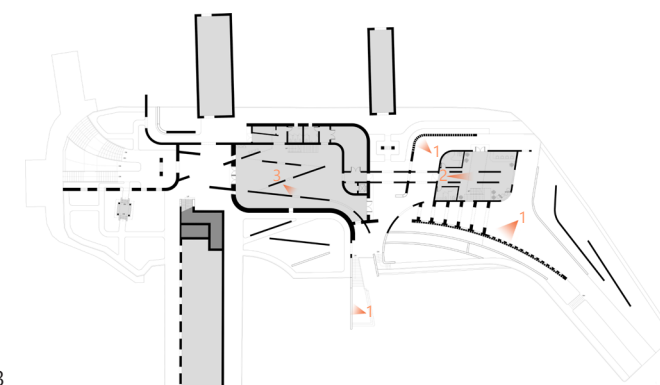

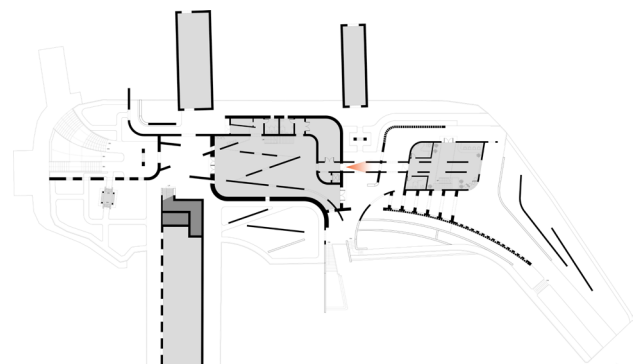
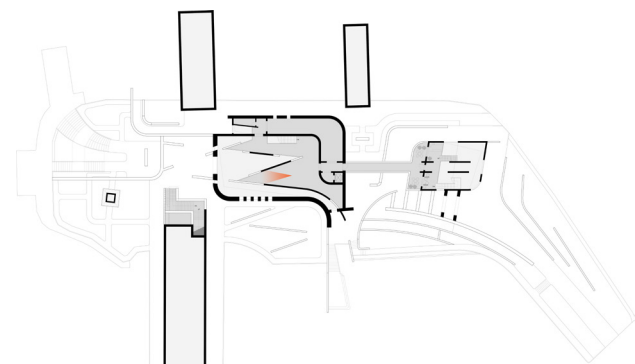
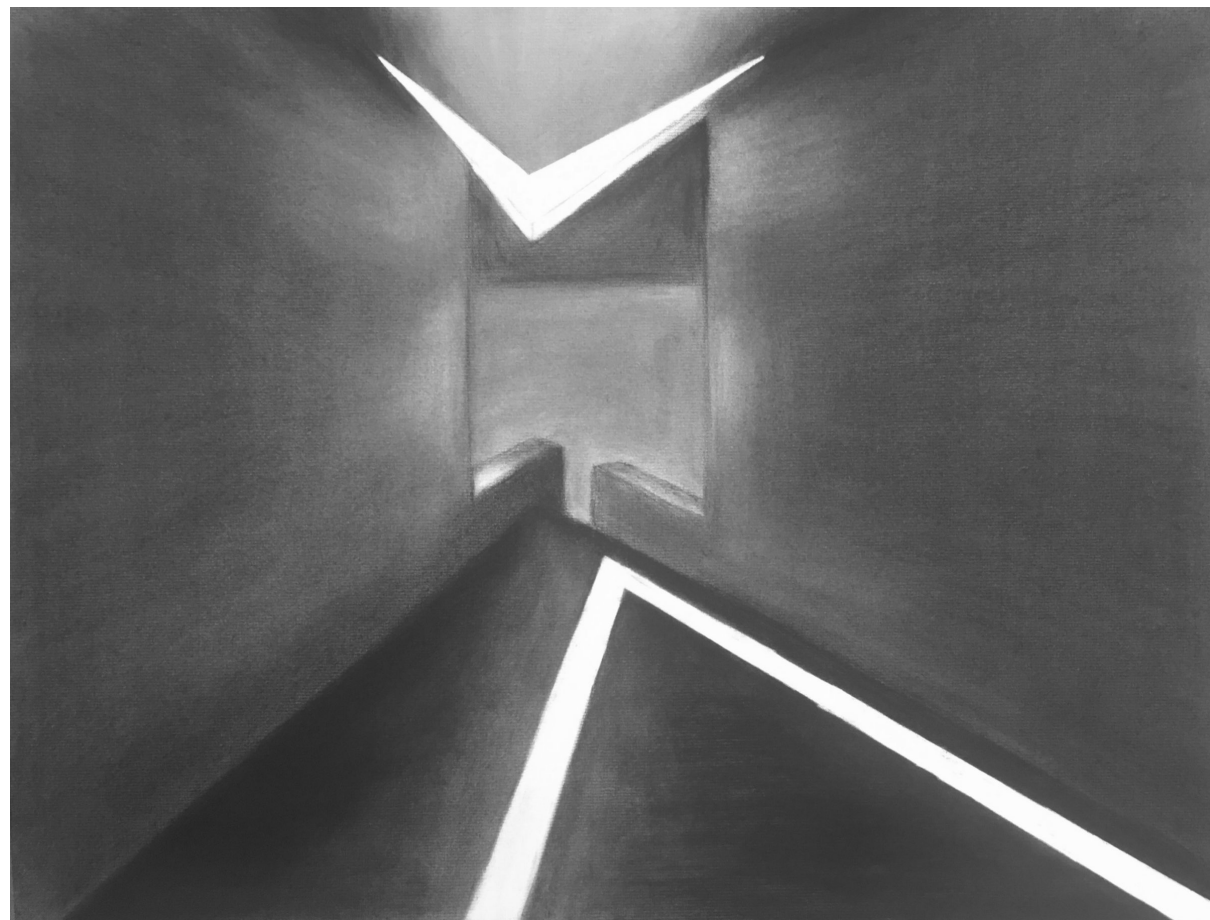

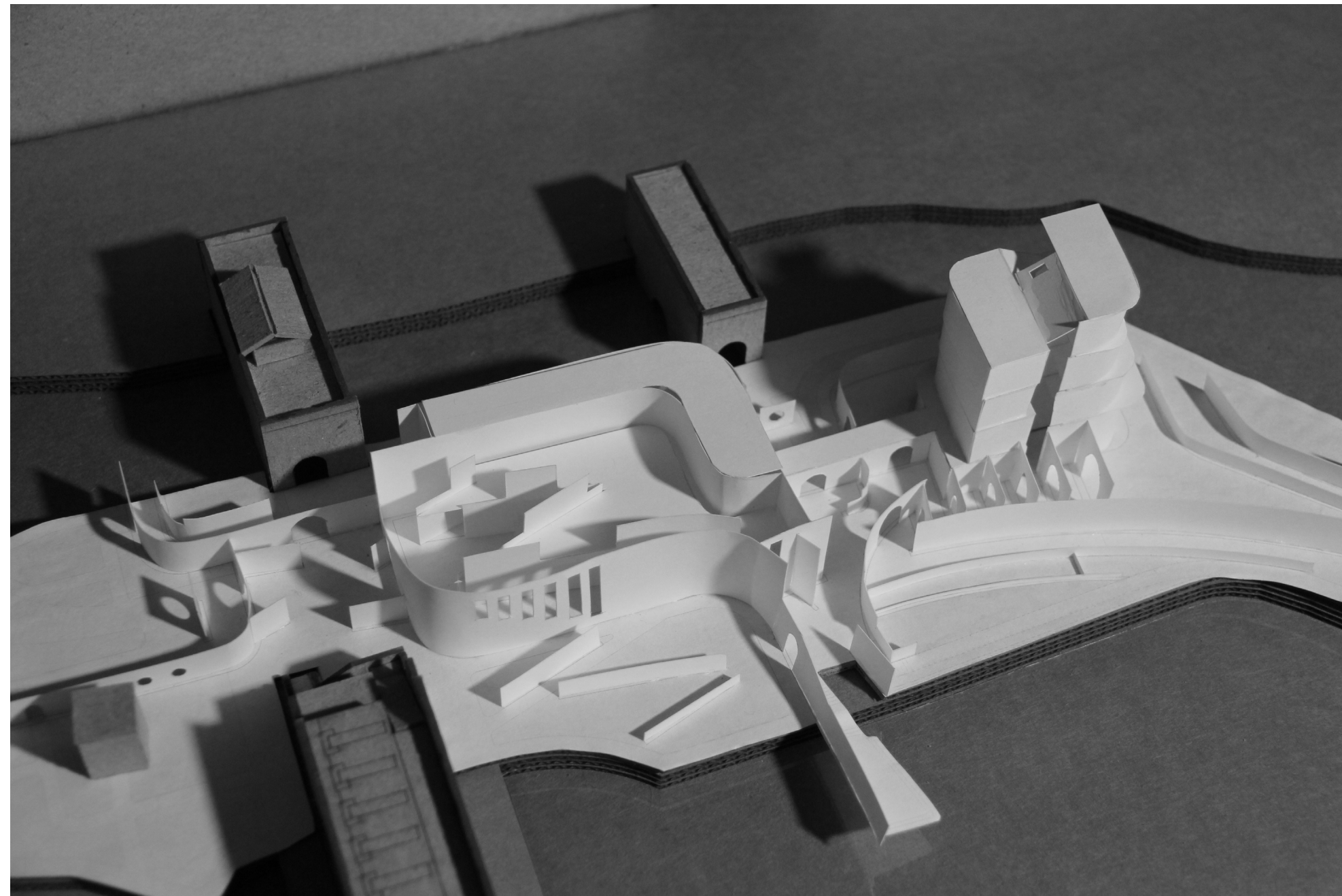
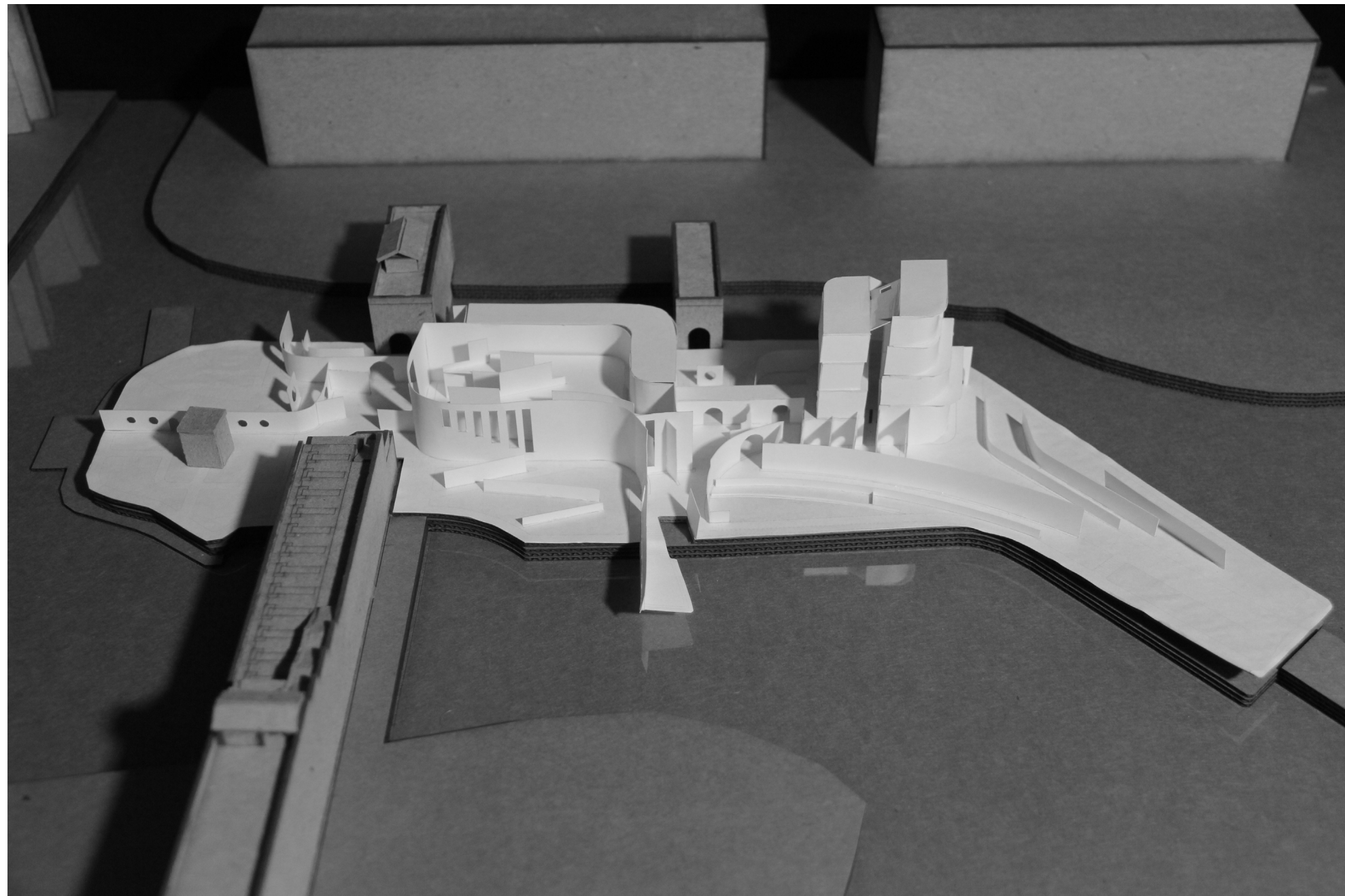



Curved walls are shown in this perspective. When people come into this exhibition space, curved walls guide them from the entrance. Then people follow the sequence of the diagonal walls. That is an opposite feeling compared with the feeling in exterior spaces.

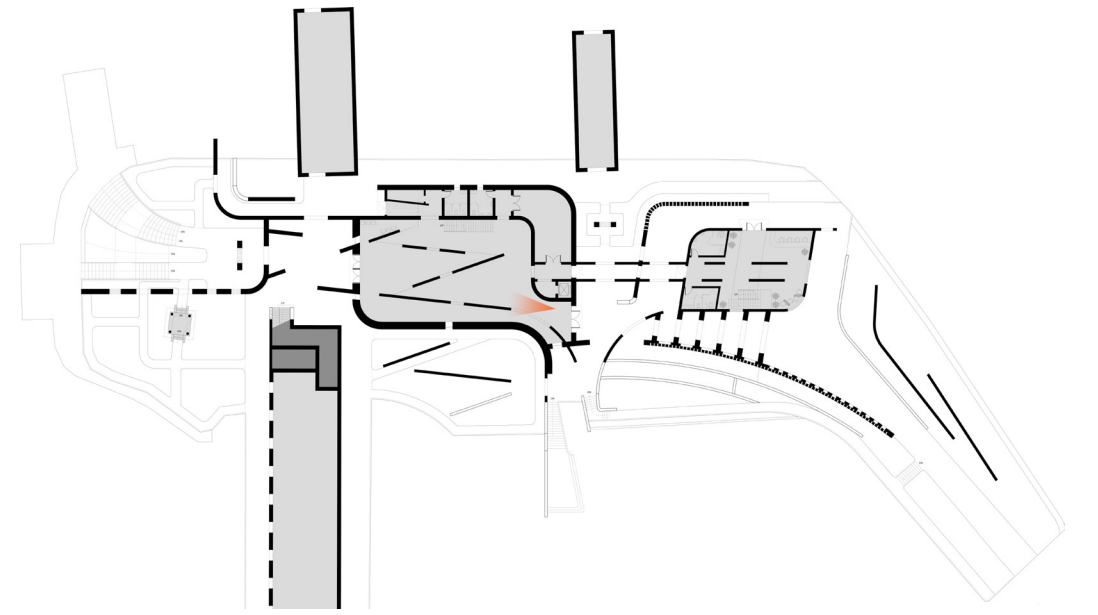



These diagonal walls are made of concrete. They are surrounded by brick walls. In this room, two feelings created by two kinds of materials. Brick is heavy and thick. Concrete is light and thin. People can touch the walls, see the placement of walls and feel light changes in this room.

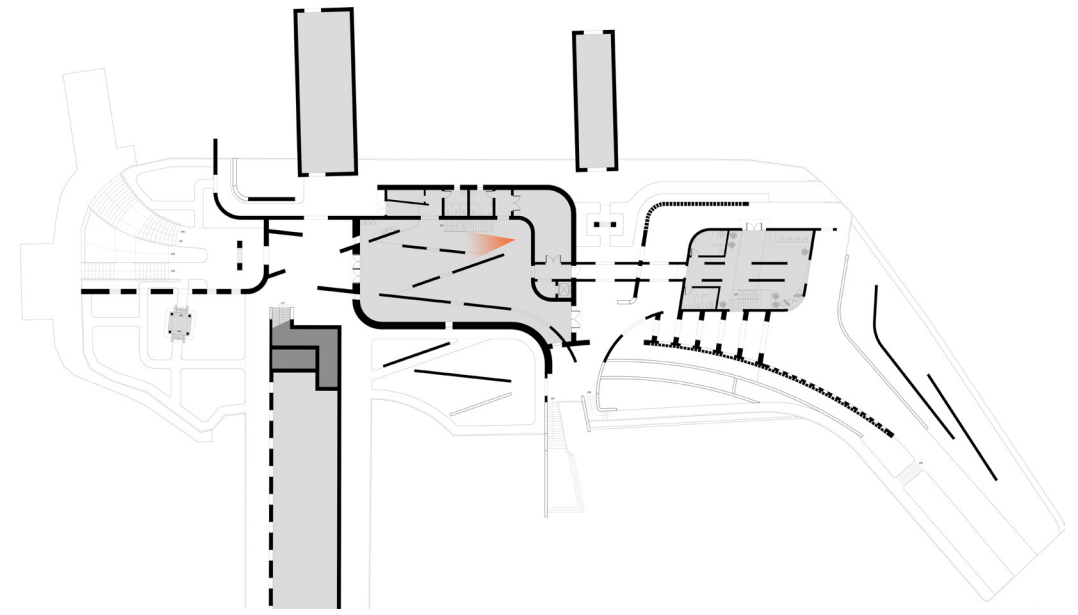



Shape corners can be seen more clearly on the second floor. Standing at different points, people have different views and feelings of the whole space and the special designed roof.

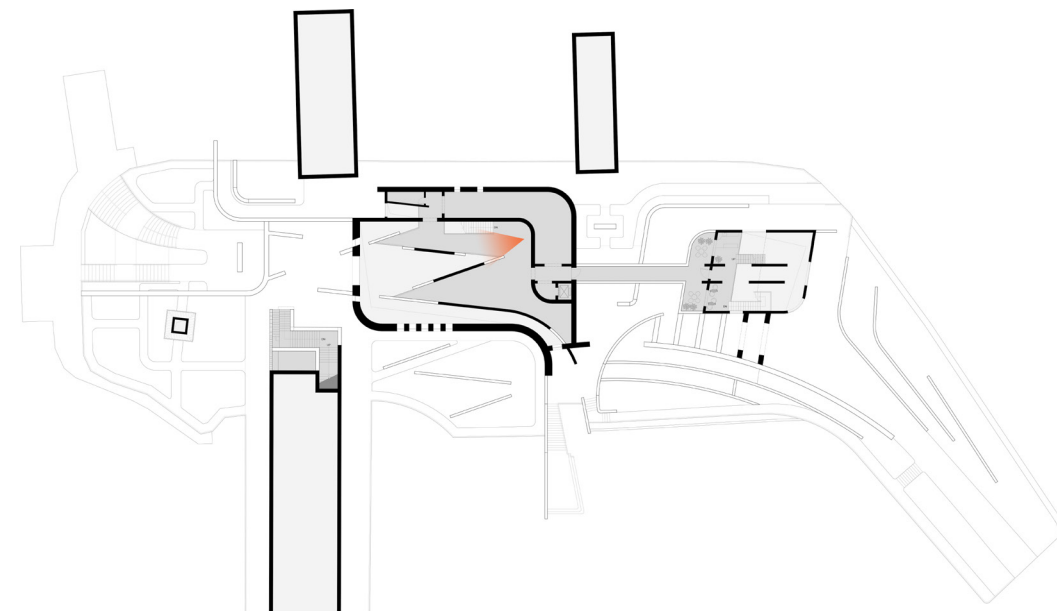

Conclusion

Beginning this thesis from studying walls of different scales and ending it with a new island, I deeply understand the meaning of walls in architecture. In this thesis, different forms of walls, material and detail studies, space design, and landscape rethinking are combined together on this island. They are all important elements which can influence people's experience in these walls. The new walls with new feelings really create a dialogue between the history, the environment and people.

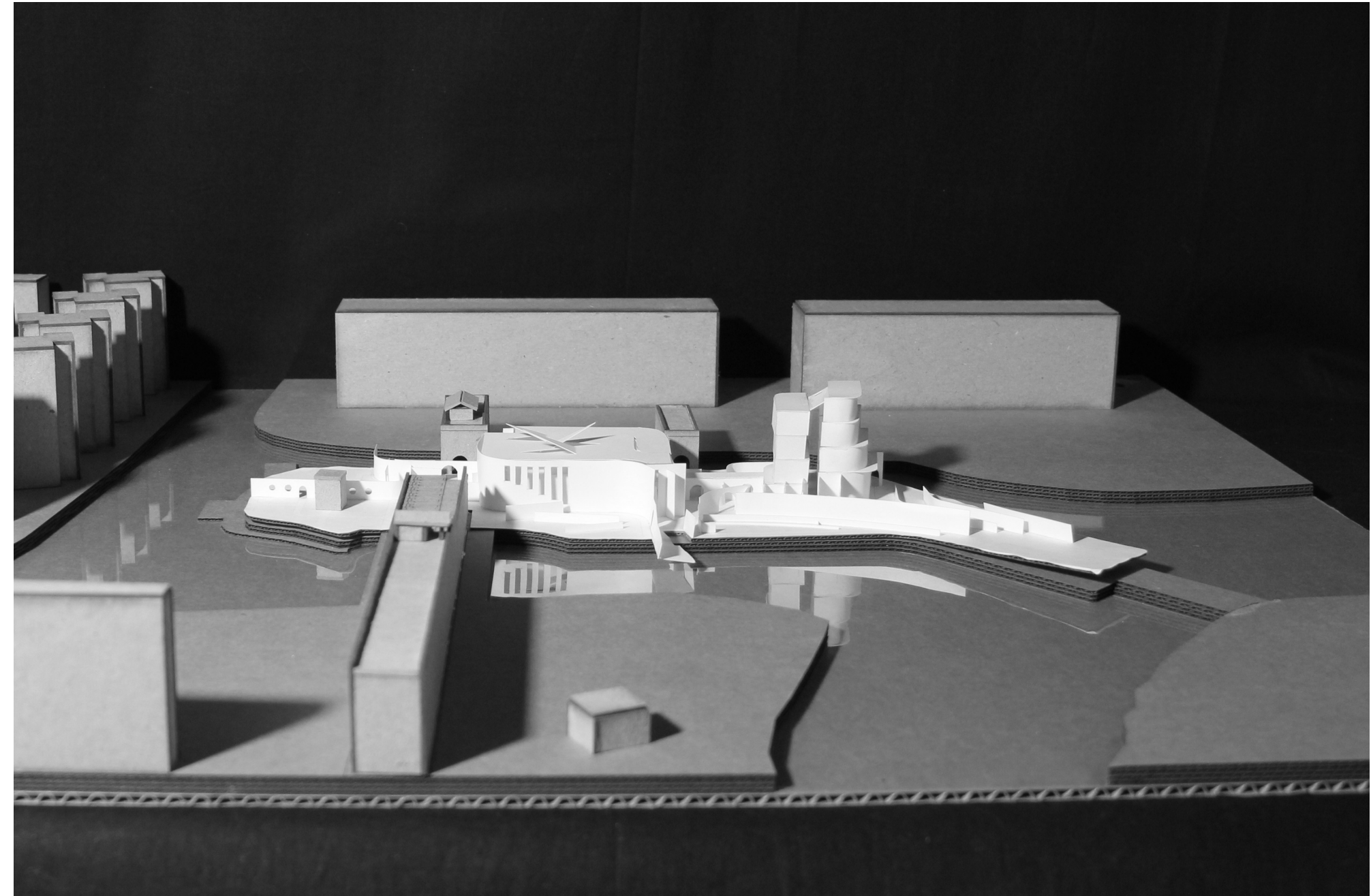

Bibliography

Ronald G. Knapp, *China's walled cities*, Hong Kong, New York : Oxford University Press, 2000.

Spring 1981 China Study Group, The University of Minnesota Institute of Technology; School of Architecture and Landscape Architecture, *Walls : inside China and its architecture*, University of Minnesota, 1981.

Frank D.K. Ching, *Architecture, form, space & order*, New York : Van Nostrand Reinhold, c1996.

Shlomo Aronson, *Making peace with the land : Designing Israel's landscape*, Washington, DC : Spacemaker Press, c1998.

Francis D.K. Ching, *Building construction illustrated, 5th ed.*, Hoboken, N.J. : John Wiley & Sons, c2014.

Image Credits

All images were made by author except those listed below.

Page 12 Left side photos <https://arcspace.com/feature/21st-century-museum/>

Page 13 Left side photos and right side plan drawing <https://www.archdaily.com/109135/ad-classics-barcelona-pavilion-mies-van-der-rohe>

Page 14 Left side photos <https://www.archdaily.com/66661/66661>

Page 15 Photos and images <https://www.gooood.cn/blossom-pavilion-by-atelier-deshaus.htm>

Page 16 Left side images <https://www.gooood.cn/tampere-art-museum-by-3gatti.htm>

Page 17 Photos and images <https://www.dezeen.com/2013/11/06/volcanic-slab-d2c-flagship-store-by-3gatti-architecture-studio/>

Page 18 Left side images <https://www.pinterest.com/>

Page 19 Left side photos https://www.google.com/search?q=%E7%85%A7%E5%A3%81&source=Inms&tbn=isch&sa=X&ved=0ahUKEwiv_PScroDIAhWPwFkKHU_YDWgQ_AUIEigB&biw=1536&bih=722

Page 20 Left side photos <http://www.epochtimes.com/gb/18/11/7/n10835148.htm>
right side photos <https://www.pinterest.com/>

Page 22 Photos <https://www.pinterest.com/>

Page 26 Photos <http://travel.cctv.com/2018/06/25/ARTI3WStejC64KEtCGjLpfVi180625.shtml>

Page 58 Material images <https://www.sketchuptextureclub.com/>