

Solar House

Yusef Nawas

Thesis submitted to the faculty of Virginia Polytechnic Institute and State University in partial fulfillment of the requirements for the degree of

MASTER OF ARCHITECTURE

Robert Dunay

(Committee Chair)

Dr. James Jones

Steven Thompson

Dr. Mehdi Satareh

VIRGINIA POLYTECHNIC INSTITUTE AND STATE UNIVERSITY
COLLEGE OF ARCHITECTURE AND URBAN STUDIES

SEPTEMBER 2003



SOLAR HOUSE

YOUSEF NAWAS

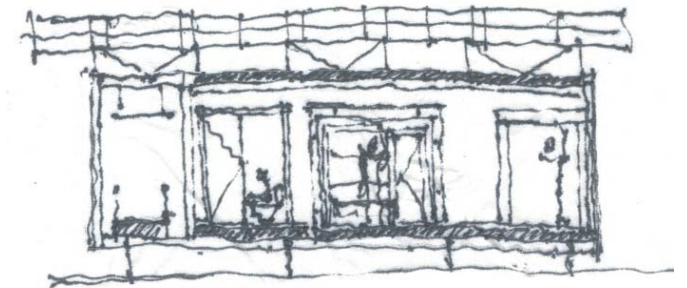

This book is dedicated to my mother, father, and my sister Nadia, for all their love and support, and also to aunt Olga, uncle Yousef and aunt Salwa.

Content

Introduction	7
Architectural Idea	17
Rooms	27
The Project	35
Assembly	51
Technology	59
Postscript	73
Acknowledgements	77
Bibliography / Credits	78
Vita	79

Introduction

Opposite: image of the Solar House with the movable photovoltaic structure attached to the main frame.



The finite and the infinite

09

"There are at least two kinds of games. One could be called finite, the other, infinite. A finite game is played for the purpose of winning, an infinite game for the purpose of continuing the play."

(James P. Carse Finite and Infinite Games)

Of the two inquiries, one is a competition to design a solar powered house that follows strict requirements and is judged upon highly specific criteria. This game takes place in a certain time on a certain location. The other game is an ongoing search for the future house. Of these two inquiries, the later carries greater meaning in itself, because it is a philosophical question. It addresses the question of how we should live and investigates what we are. The questions go beyond the physical requirements of the finite game which is the basic competition.

The project had to be found within the boundaries of the bigger question. *"A finite game can exist in an infinite game but not visa versa."* *(James P. Carse Finite and Infinite Games)* The goal is to weave the solution through building the connection between both, even though they have different essences. The competition is characterized with its seriousness and its preconceived results, due to the fact that the variables of the solution are contained within its rules. However investigating the bigger question demands playfulness-which is playing with the boundaries themselves and reinterpreting what the house is to attain a dramatic solution.



*Top: Image of the Solar Village on the National Mall in Washington, D.C.
Right: a 3d model of the Solar House during the design phase*



The future house

11

Through out the years there have been many finite examples of the infinite game: "the quest for the ideal house", yet to predict the future house is also to predict the social and cultural future through questioning how we live and what we to aspire to.

Le Corbusier in his book identified the house as a machine for living. Later period there were many followers who adopted that statement and their proposals were based on it. Reyner Banham who was in opposition to that idea, wrote in 1969 "The functionalist slogan the house is a machine for living is not productive because it begins by presupposing the idea of a house". Martin Heidegger stated in his essay "Building, Dwelling and Thinking" that the sense of place is not established just by building a building but rather by finding for ourselves the means to recognize what is home.

The modern quest started with Walter Gropius. He worked on several projects for factory built houses using modular building techniques for its economic and aesthetic benefits. In the twentieth century the main focus was on flexibility and adaptability as a key innovative element. None of the models of these houses have passed beyond the prototype phase. It is generally believed that the main reason was the sponsors; for they were either unready for it as in the case of Albert Frey when the traditional building companies fought against it, or they regarded the projects as something to excite the crowd with. Yet we cannot deny the influence of those visionary architects and their products had and continue to have on the development of architectural form.

1928 Aluminaire house

The Aluminaire House was designed by the Swiss architect, Albert Frey. It was the first all aluminum and steel house in the United States. The house had many innovative construction techniques, and was erected in ten days. The furnishings designed by the architect had multiple uses, like suspended beds and moving panels to maximize the feeling of space. The house still exists in Central Islip Long Island, New York.



1946 Dymaxion Dwelling Machine

Dymaxion Dwelling Machine was a further development by Richard Buckminster Fuller from the 4D house that he designed in 1928. It was conceived as a kit home for mass production to achieve high quality environment for large numbers of people at an affordable cost. The house managed to include two bedrooms, two bathrooms, a kitchen, and a sitting room. Making use of natural scientific and technological resources produced a more efficient and beneficial living support systems.



1957 Monsanto House

The Monsanto House is a cruciform shape and synthetic construction designed by MIT. There is hardly a natural material anywhere, the floor, walls and ceiling are made of plastic. The design takes advantage of the unlimited flexibility of plastic in buildings.



1982 Autonomous House

Light and transparent domes allow for the creation of internal micro climates. Foster developed this idea further in that project conceived jointly with Fuller. The investigation aimed at flexibility of use, reducing energy consumption, enclosure of the greatest possible space with the smallest area of skin, lightness, and as much natural light as possible.



2001 House_n

This on going research that is focused on how the home and its related technology meet the opportunities and challenges of the future. MIT established the "living laboratory" which is supposed to be a home research facility that is targeted towards proactive health care, just-in time information, effective human- computer interaction, and activities of daily living. These criteria are met by sensing infrastructure, monitoring, indoor air quality, and interior infill strategies.

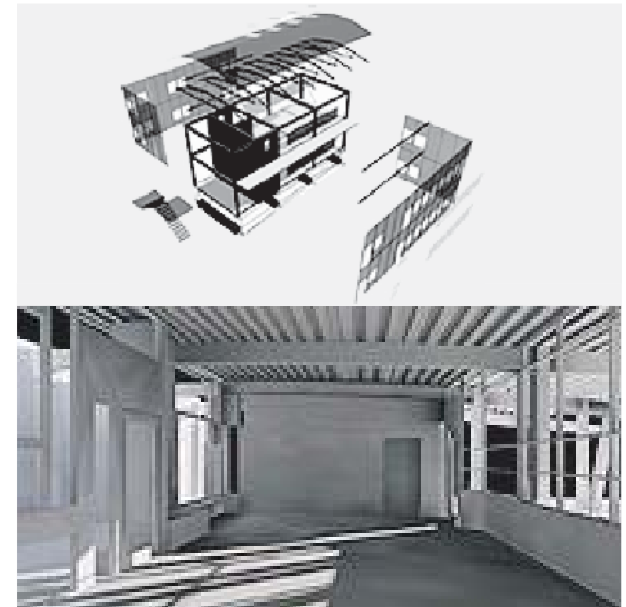

The competition

13

A political statement

The Solar Decathlon, was an inter-collegiate, inter-disciplinary, and construction design competition. By means of integrating architecture, technology, and dwelling, the challenge is to design both a self-sufficient and sustainable solar powered house. The first competition was housed on the National Mall in Washington DC. The house, which was among fourteen other houses from different schools, gathered along an axis forming a solar village emphasizing a political statement supported by The Department of Energy on how to see the future American house.

The intent of the competition was to exemplify design principles that would increase the public awareness of the aesthetic and energy benefits of solar technology in addition to stimulating accelerated research and development of renewable energy, particularly in the area of building applications. Through promoting renewable energy as a viable and attractive alternative to current nonrenewable sources and, at the same time maintaining the life style of the people, and each house has to have the same equipment and appliances as any regular American house and operate in the same way.

The competition began on the 10th of October 2002, which is a hard time to predict the general weather condition as the seasons change from Summer to Fall. The duration of the competition was one week. Each team was given five days before and after the event to erect and dismantle their house and leave the site.



Left: a computer model of the Solar Village on the National Mall in Washington, D.C. before the competition.

Right: image of the Solar House during the competition.

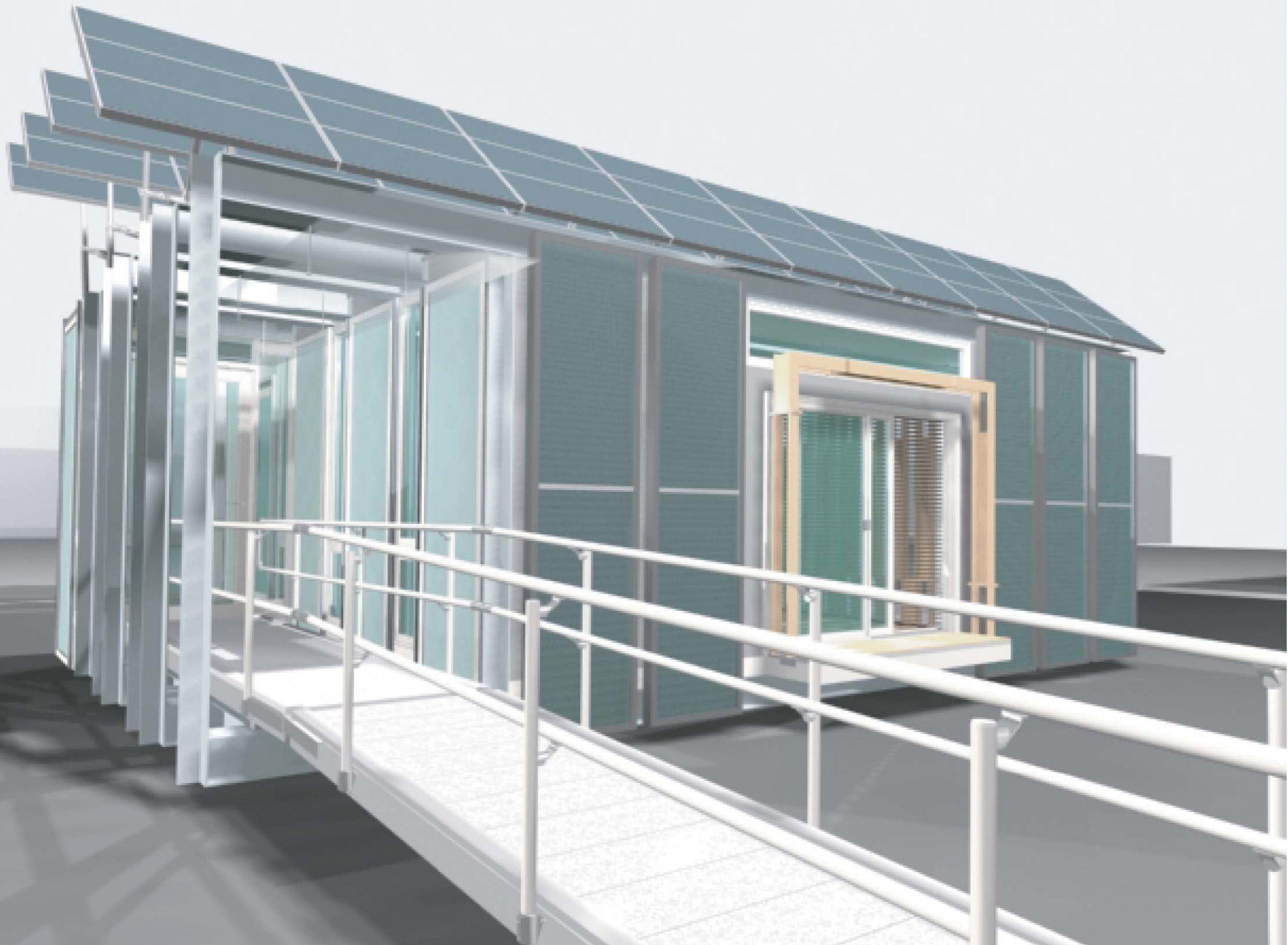



There were ten competitions, some events were qualitative like the Livability competition, with a psychological and philosophical nature. The investigation of human behavior, self, mind, body, and place, along with the study of precedents and culture, were seen as forming the underlying structure for the true nature of our built environment. Those are influences that affected how we saw the future house, with the new criteria and functions that dwellings should satisfy, and the new technology that needed to be integrated. Other competitions were quantifiable like renewable energy, production and consumption, refrigeration, lighting. These had a particular and mathematical nature, with a strong impact on the design in terms of criteria and method. Working with input from specialists and scientific-based methods was crucial in facing the challenge of meeting complex briefs and making innovative solutions using sophisticated constructional technology.

A team was composed of architecture, industrial design, mechanical engineering, and electrical engineering students. Faculties from those different disciplines, along with the corporate and individual sponsors, were also integral to the body of the team.

The project passed through all the stages of design from idea, to drawings, to testing, to experimenting, to construction, and back to ideas. The working process was like an open university composed of thirty-five to forty people at different times. The nature of the work required the widest range of disciplines. The challenge was how to approach that particular integration and maintain integrity at the general and detail scales.

Top: interior image of the Solar House during the competition.

Bottom: the Solar House on the National Mall in Washington, D.C. during the competition.

Right: night image of the Solar House.





Architectural Ideas

Opposite: model of the Solar House in the initial stage

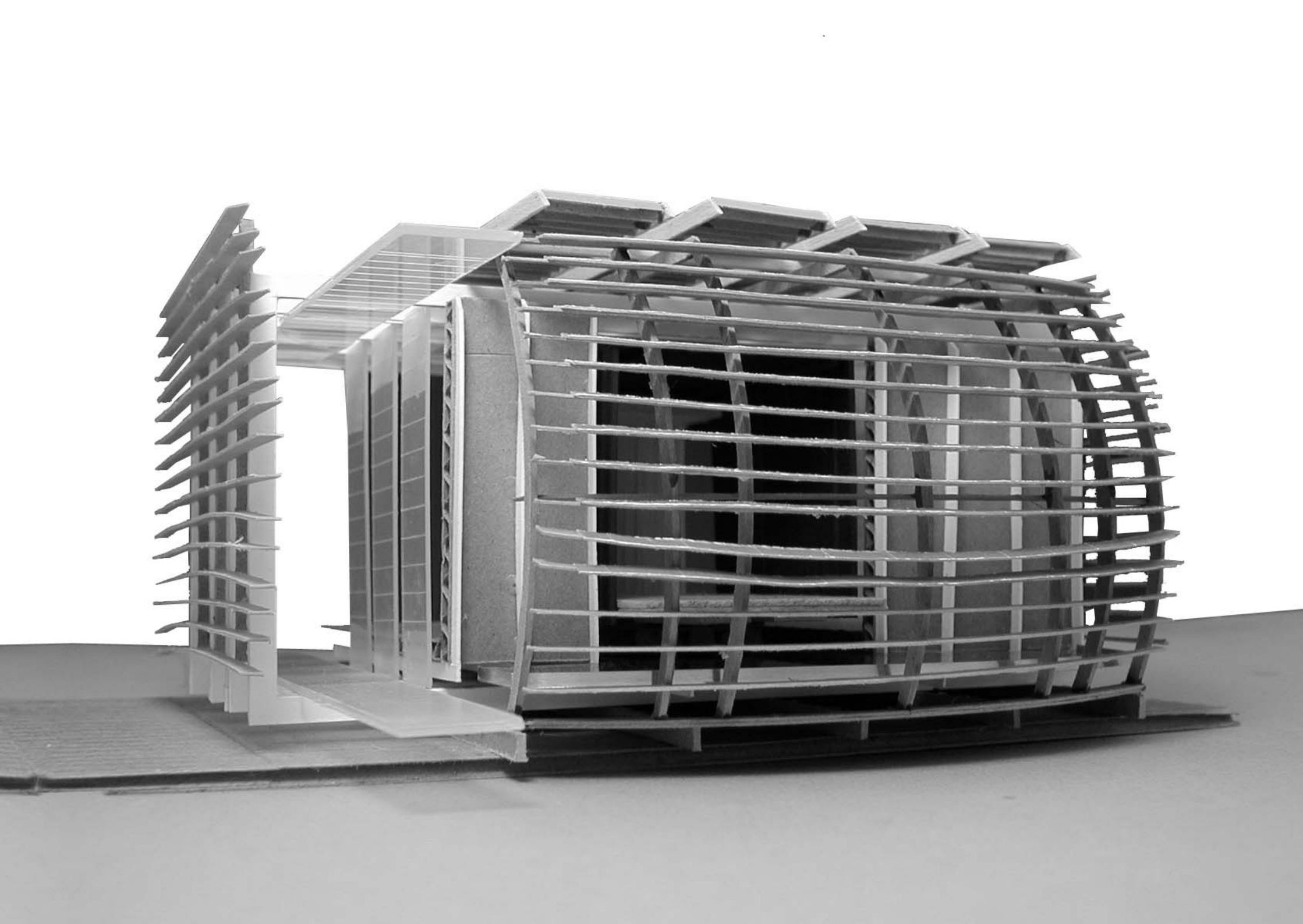

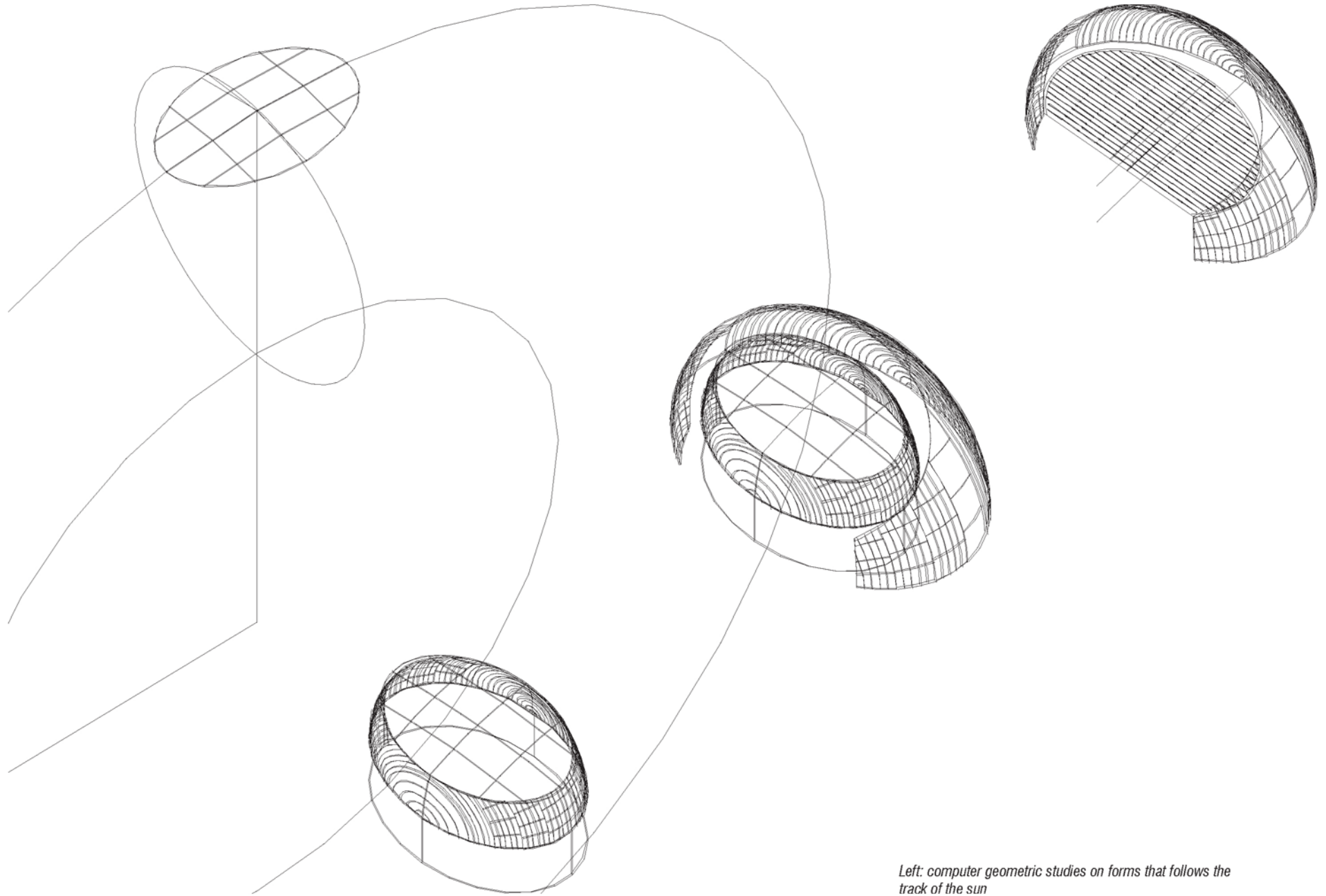

Left: computer geometric studies on forms that follows the track of the sun

Solar geometry

A solar house has an obligation to the sun physically and geometrically. Since the beginning of the project, there were two ideas that guided the investigation: the track of the sun and the quality of the rooms. As for the first, the focus was to generate a form that could track the sun by maintaining a 90 degree angle between the angle of incidence and the surface of the geometry throughout the seasons and the time of day. From the sun charts for the Washington, D.C. area there were two geometries realized: one was a slice of an ellipsoid facing the sun as an elevation that extends to the east when the sun rises and sets 30 degrees west of south. Another geometry was a slice of a torus that stretches towards the east and west to maximize the solar exposure.

Bellow: Sun Charts for Wasington DC
Source: Mazria, Edward. *The Passive Solar Energy Book*, c 1979.

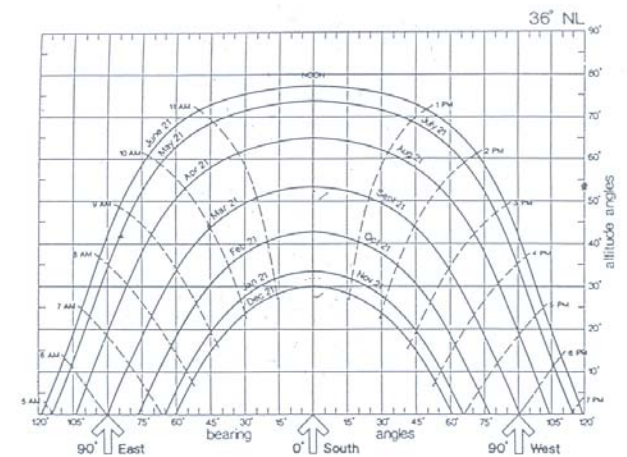

Two Rooms

21

The house is composed of two rooms, one inside the other, emphasizing two different natures by contrasting conditions such as dark and light, and by using the physical as a conduit to the spiritual in an introverted and extroverted focus.

In the nigredo of alchemy, Black is associated with generative night and raw matter, while in the Albedo of alchemy white is linked to the sun and lustration. The bedroom is the small dark object that floats in space defining the spacial characteristics of the bigger white monochrome enclosure.

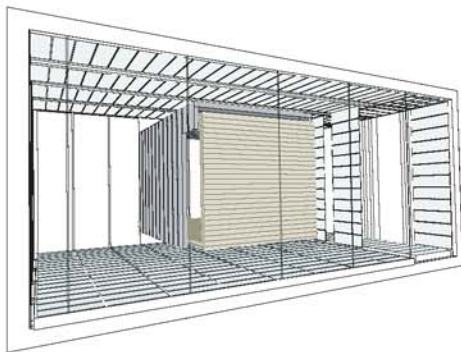

Top: a computer 3d drawing showing the north side of the initial idea (a room within a room).

Right: a computer 3d drawing showing the south side.

Opposite: a physical model of the initial idea showing the two rooms with two different characters.

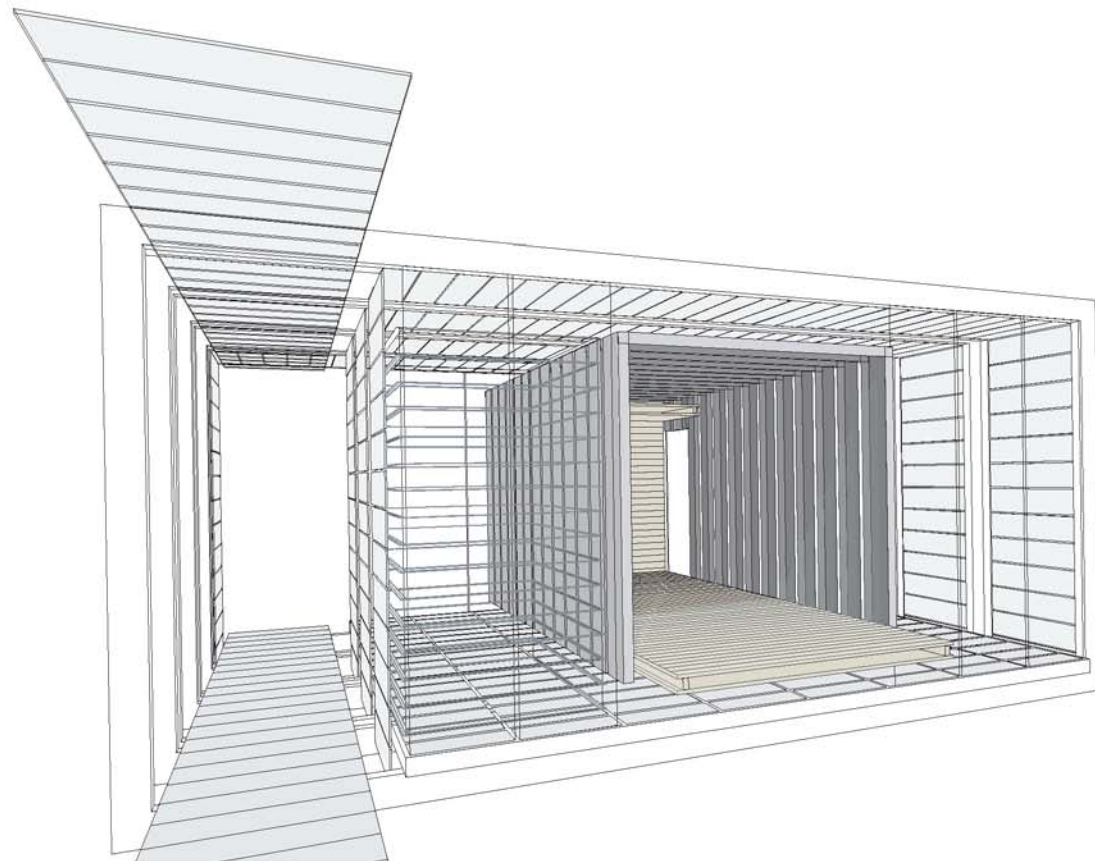

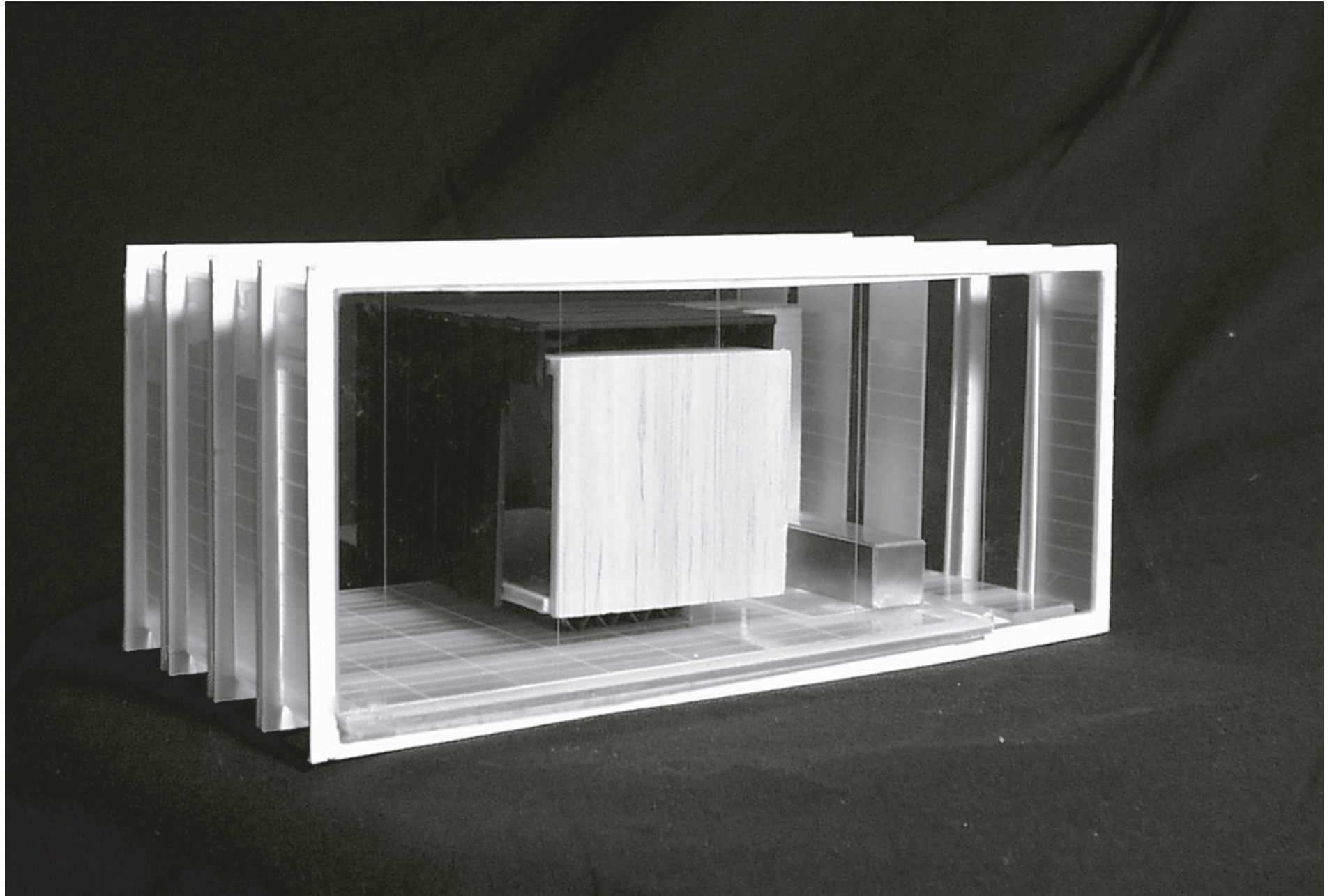

Plug in modules

23

The spatial condition of a room within a room is emphasized through the insertion of bedroom and bathroom modules into one large open volume. The sleeping area is a dynamic space; with moveable parts which to allow for different spatial configurations.



Left: physical model of the Solar House.

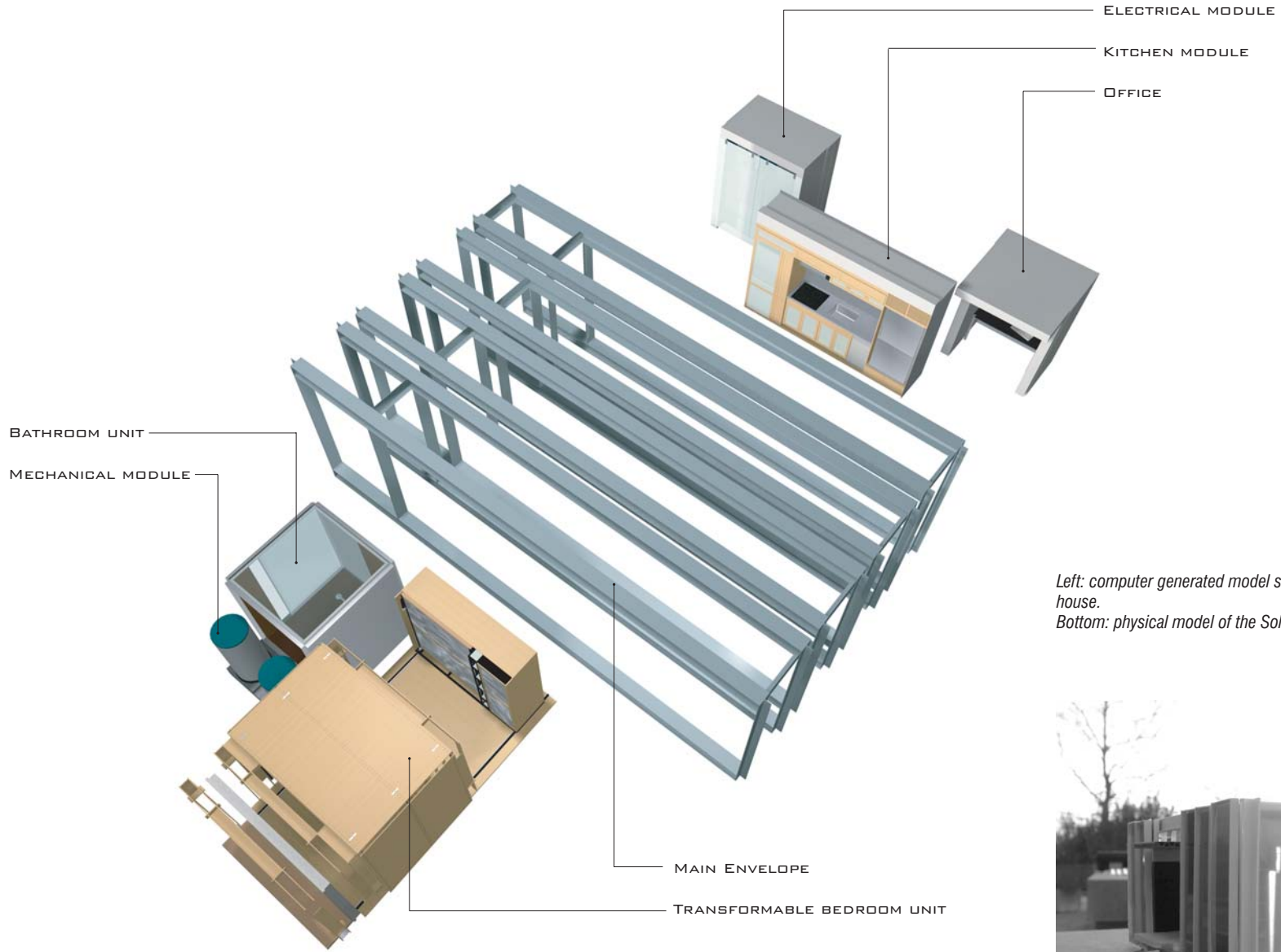

Left: computer generated model showing all the components of the house.
Bottom: physical model of the Solar House.



Transformable room

25

The bedroom unit is composed of stationary and movable parts. Part of the room such as the floor and the stationary structure extends beyond the conditioned space to the landscape as a continuation for the space and a link to the exterior environment. The interior components are arranged in three parts: the main body as the stationary part is located on the south module, the sliding shell suspended on two sliding upper tracks connected to the main body of the house, and a sliding closet that slides on bottom tracks. The closet holds a Murphy bed on one side and a foldable dining table on the other. Having two moving components allows for multiple configurations, so the same space can be utilized differently. The room can expand to full length, forming a full scale bedroom unit. Partially expands to form a bedroom and dining area, or even having the house as one big space by moving the two components towards the stationary part.



Image of the transformable bedroom, the stationary and the moving parts (closet and shell)

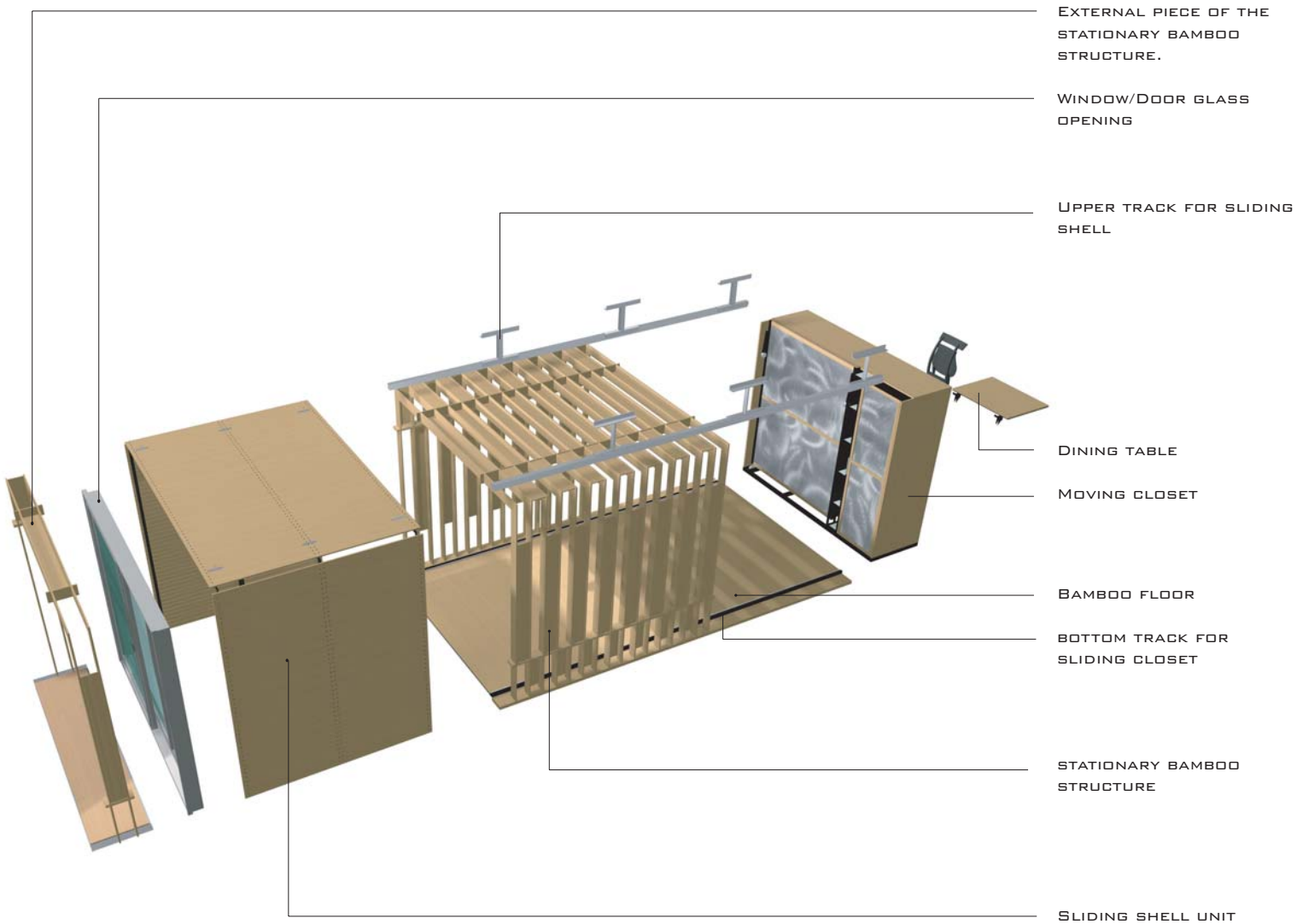

Right: computer model of the transformable bedroom unit showing the components, movable and non-movable parts.
 Top: image of the closet steel frame against the bedroom bamboo structure.
 Bottom: image of the Bamboo wall meeting the floor.



Rooms

*Opposite left: Entrance outside in.
Opposite right: Entrance inside out.*





The Organic Room

To see is to also close the eyes- to see with renewed vision.
"To speak is to have been silent- and to be silent again. And to speak no longer that takes a life time to say" . (Gunnar Bjorling)

Facing south allows direct sunlight in the space, yet the room is dark to allow a play of shade and shadow. It is a cave like room as you walk towards the edge, the sun hits the skin and emphasizes the feeling of warmth. It is a cloister in its intimate scale for it relates to the human dimension in width and height.

The space is conceived through the joining of the bamboo that creates the room. The purity in using one material and the simplicity of the structure emphasizes silence, while the use of organic substance bridges a psychological connection with nature. An emphasis on the sensual difference is established between the white monochrome and the organic room by having two poles with two different spatial conditions.

*Top: the sun shining on the bedroom wall at five o'clock in the morning.
Right: Interior image of the bedroom.*





In the Komyoji temple in Ehime Japan, Ando placed a wooden temple in the middle of a natural pond, surrounded by an annex. The hall is composed exclusively of combination of laminated wood with a simple structure.

We are always concerned with spaces that are filled with light although as beings we need dark rooms just as well we need rooms of light. Ando talks about the upper room of his house and its intermittent dimension. In some sense it allows us to enrich our souls. In our society, people are isolated, with a feeling of anxiety and restlessness. we need to identify our human relationships and our connectness with ourselves.

*Top: Komyoji temple in Ehime Japan by Tadao Ando.
Right: the bamboo structure of the bedroom unit at night.*





The white room

"Is there depth in white when white has no transparency in its nature?" (Goethe opacity).

"Perfect cloudiness is whiteness, the most indifferent, brightest, first opaque content of space." Goethe theory of colors.

The duality of whiteness in modernism developed in two: cloudiness that covers opacity and pureness that generates something new like transparency. The monochrome in Malevich must be understood as an act, defining an absolute boundary in time and space.

Whiteness is given a tone of selfconsciousness and innocence, it is incorporated in the cult of the new. The room facing north fills the space with even natural light through the translucent walls as whiteness to be considered as pure light.

*Top: living room wall using plaster and white paint as the finish.
Right: the white space receives color and light from nature.*





The Beyeler museum by Renzo Piano, is a result of series of investigations of light from above. Rooms filled with even natural yet not direct sunlight. The connection to nature is achieved through the variation of intensity of light that passes through the multi-layered roof throughout the day and seasons, which makes the room dynamic in its nature and an extension to what is beyond the physical boundaries of the static structure. The play of intensity is the variable that brings the spontaneity of nature as a part of the form which makes the room what it is.

*Top: the Beyeler Foundation Museum in Basel Switzerland by Renzo Piano.
Right: collage image of the living room.*

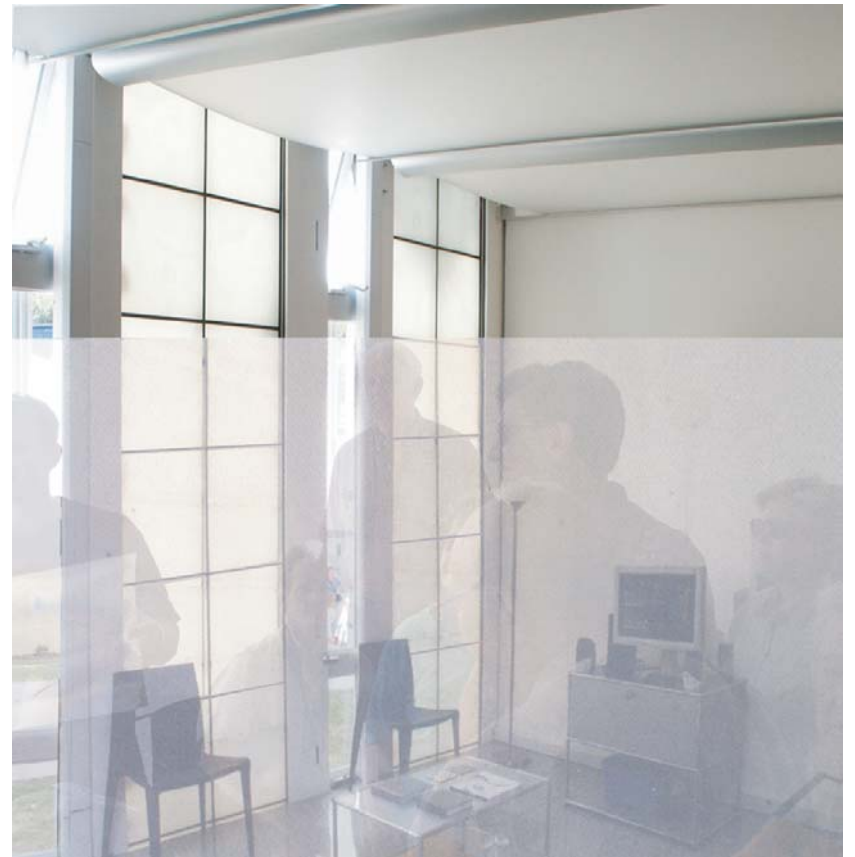

Bathroom

33

The bathroom from the outside is intended to be perceived as an object that wants to disappear. It has mirrored skin that reflects the modules on its walls giving the impression that the space expands through repetition. The space inside the room is still connected to the bigger room by having one transparent acrylic slab acting as a roof for the bathroom. This maintains the visual connection and forms a physical boundary at the same time. A connection to nature is exhibited through the use of natural textile material, cork is used as a skin that wraps the interior space, along with the direct visual connection through the skylight and the operable window which connects to the landscape.

The construction of the bathroom is conceived as a frame of aluminum angles that are welded together at their edges forming a wire frame box receiving all the planes along with the skin as infills.

Left: image showing the exterior of the bathroom with the mirror skin reflecting the modules.

Right: interior view of the bathroom looking through the transparent ceiling showing the skylight and the operable window.



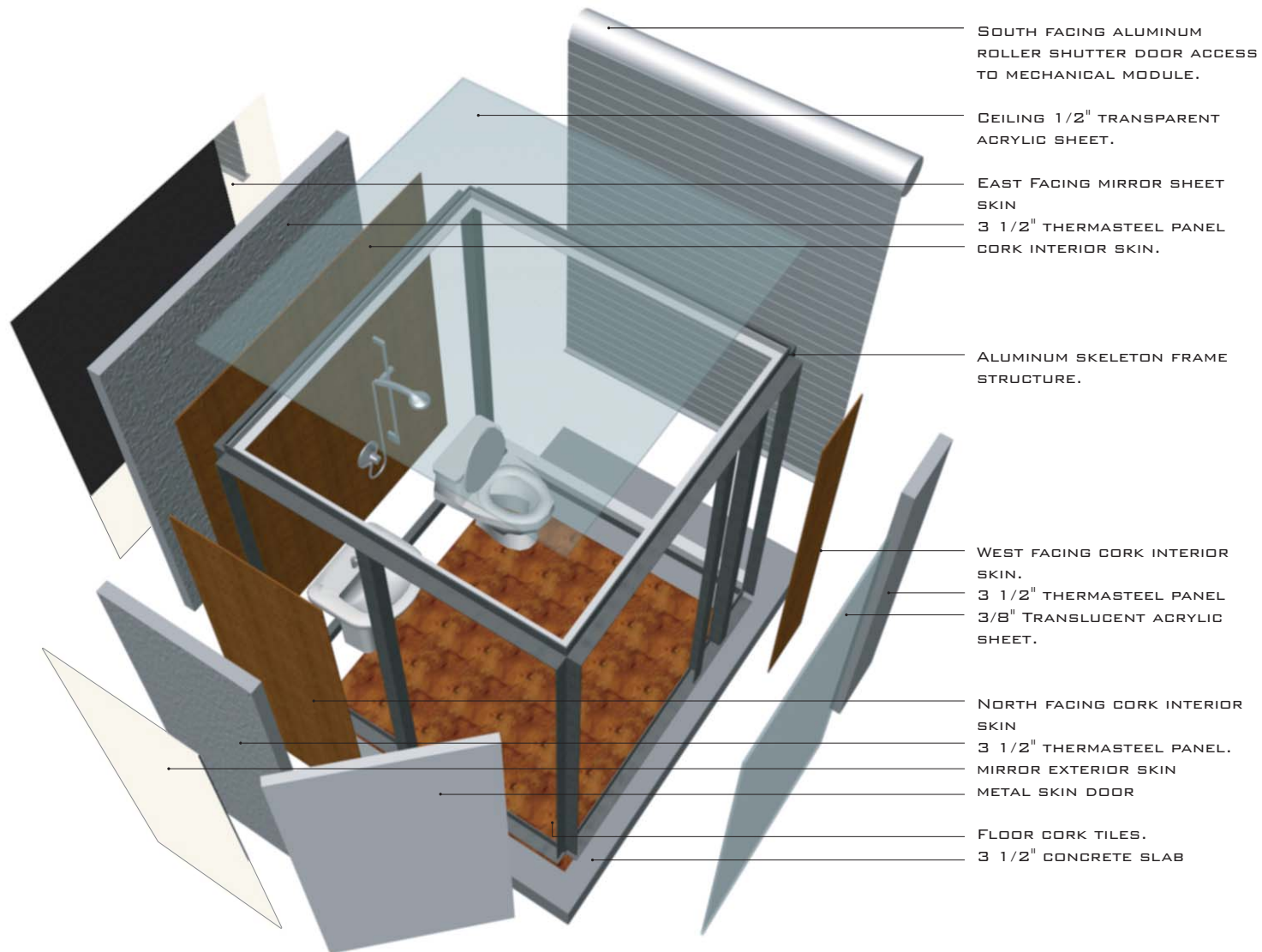

Left: an exploded 3d model of the bathroom showing all the components.
 Uper right: image showing the upper corner of the bathroom next to the window.
 Lower right: image showing the lower corner of the bathroom next to the translucent wall.



The Project

Right: site plan of the house on the permanent location facing south, between the two workshop buildings showing the shading areas during winter time.

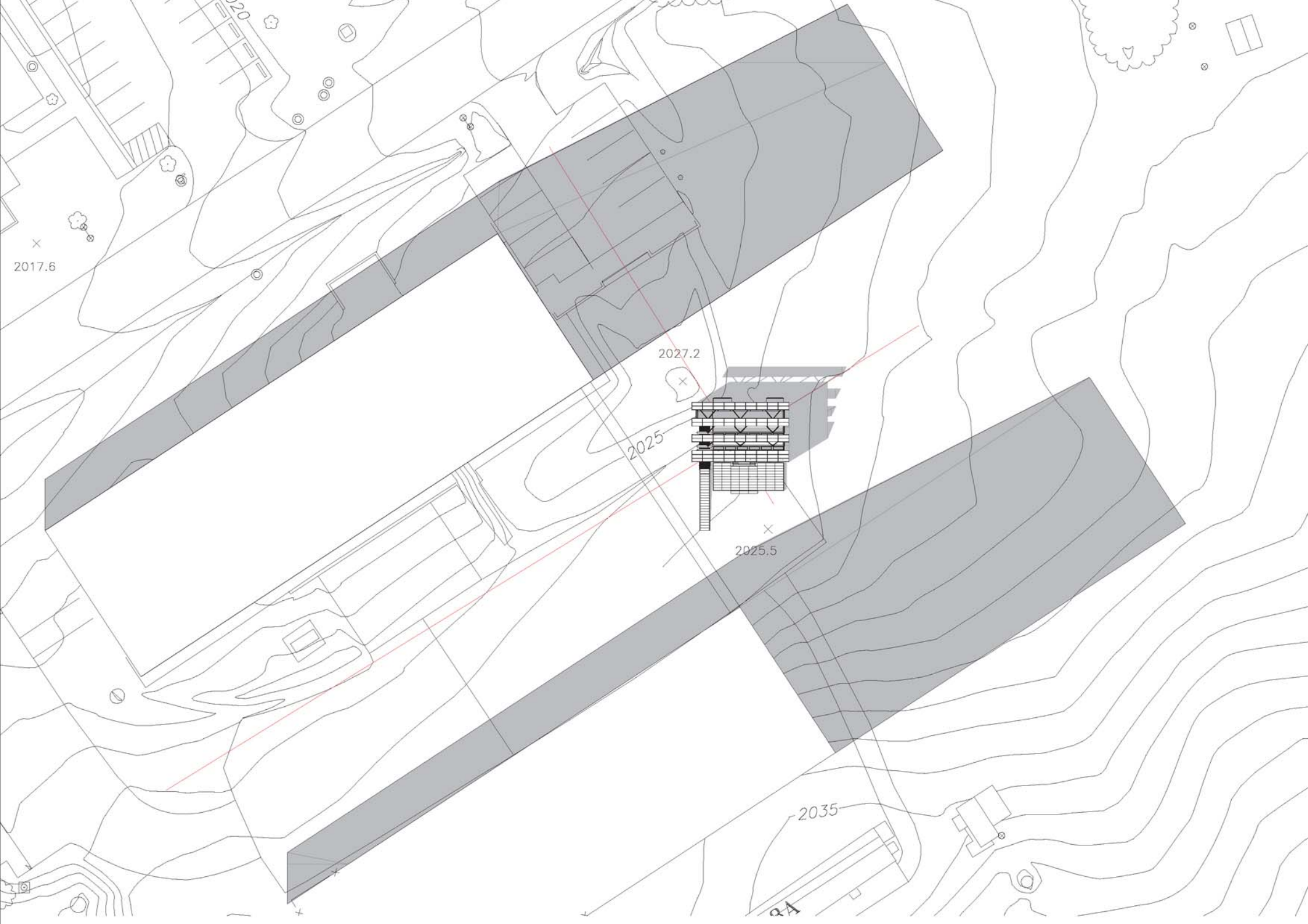

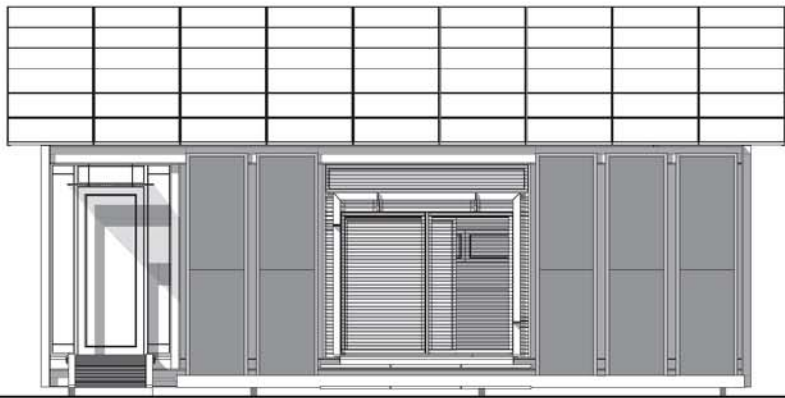

SOUTH ELEVATION

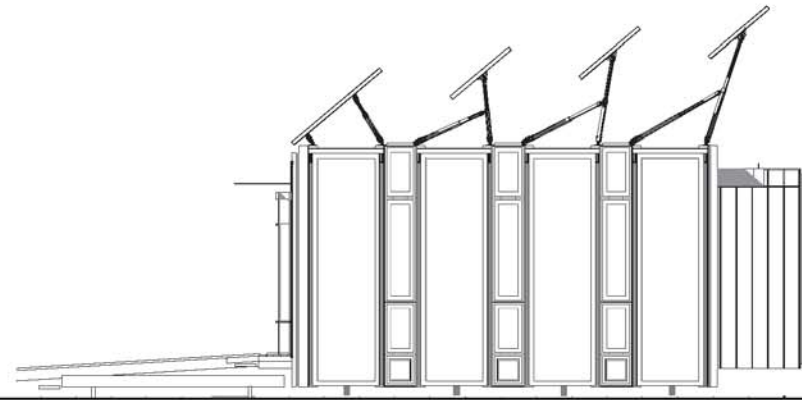

EAST ELEVATION

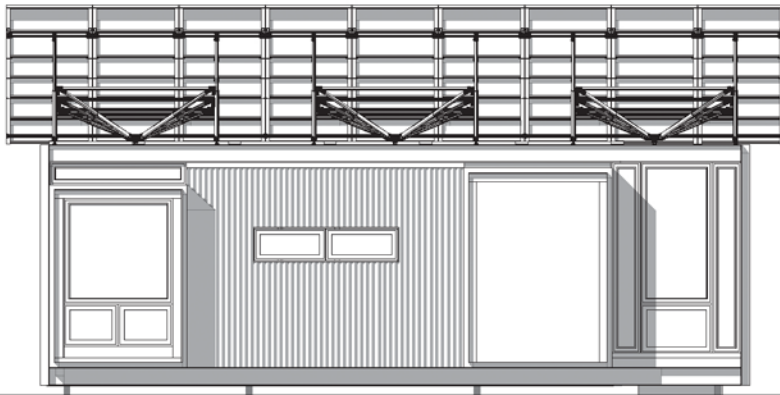

NORTH ELEVATION

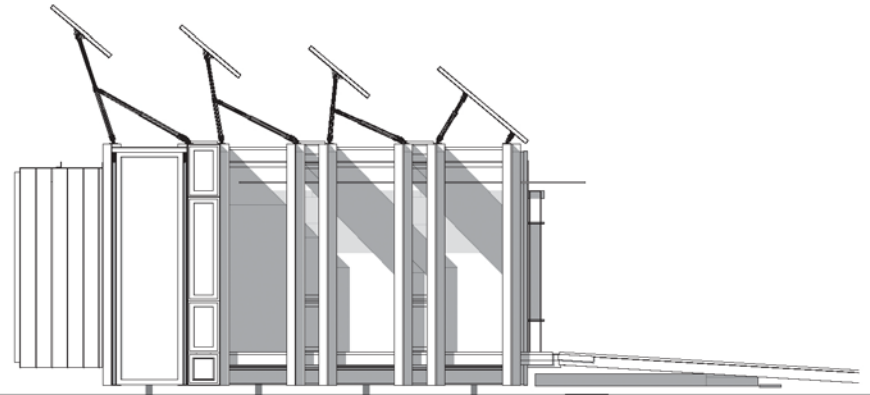

WEST ELEVATION

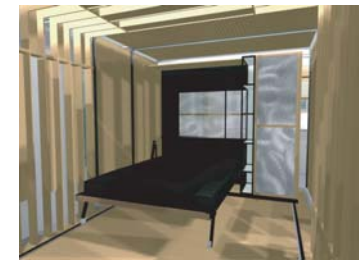
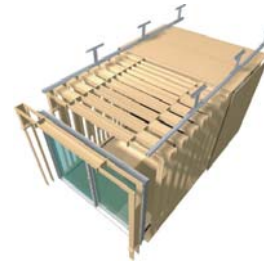

VIEW THROUGH THE BEDROOM

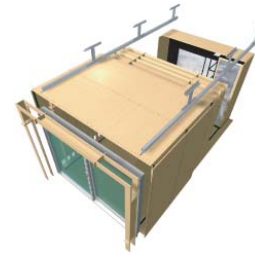

KITCHEN AND DINING AREA

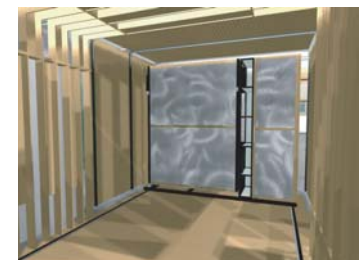
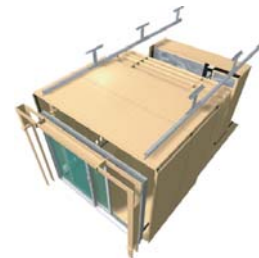

BEDROOM FOLDED

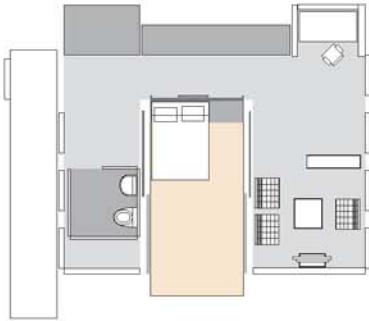

BEDROOM MODE

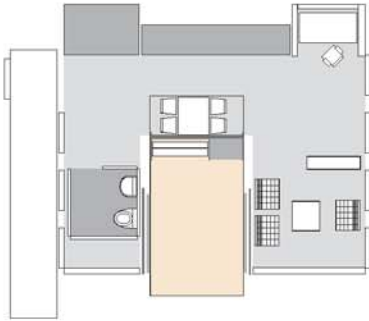

DINING MODE

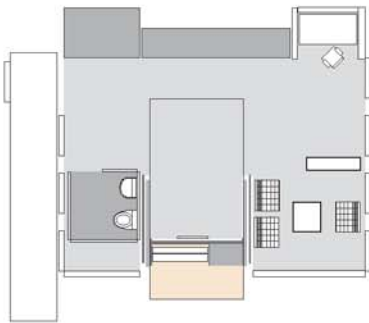

OPEN PLAN MODE

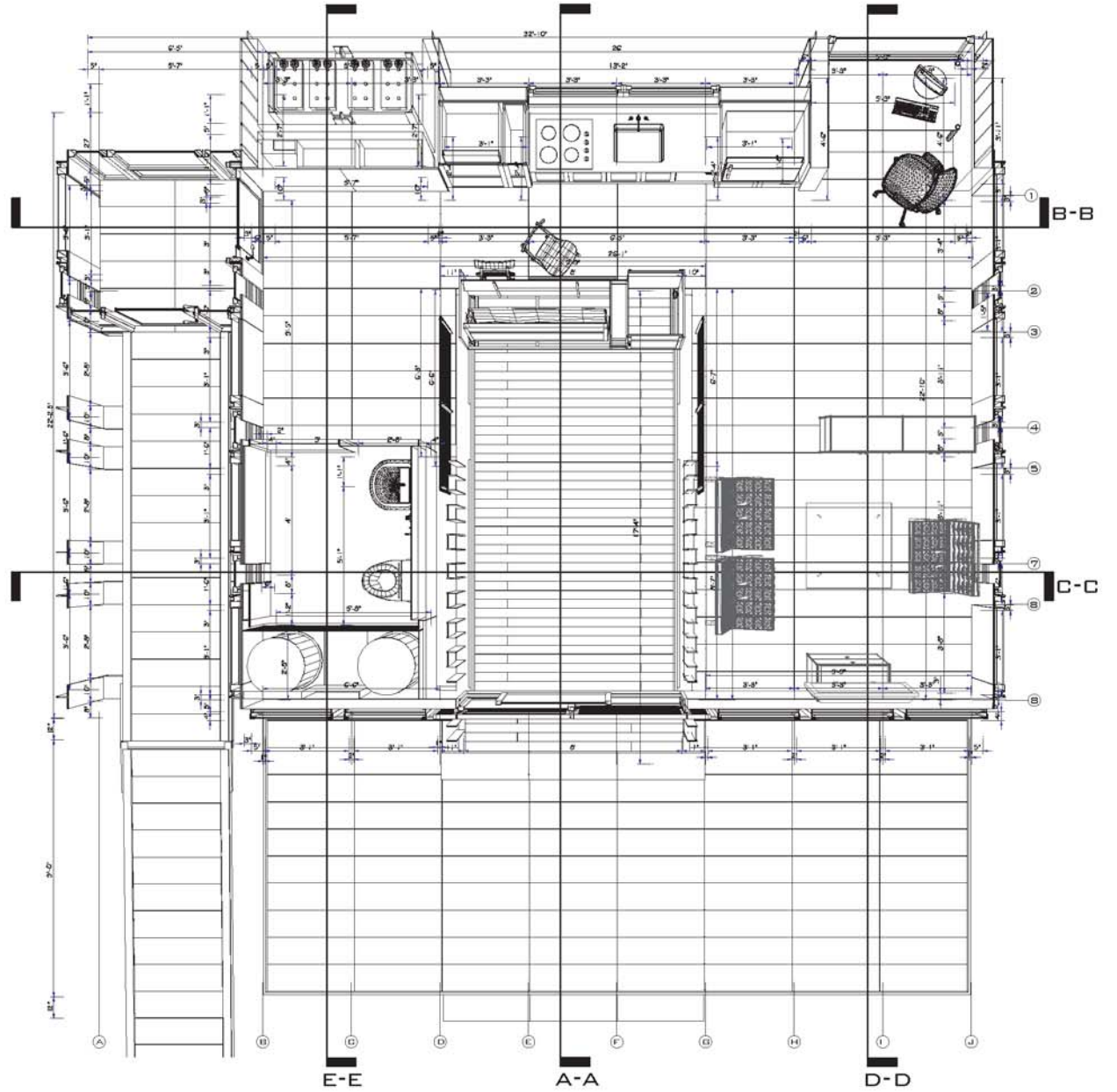



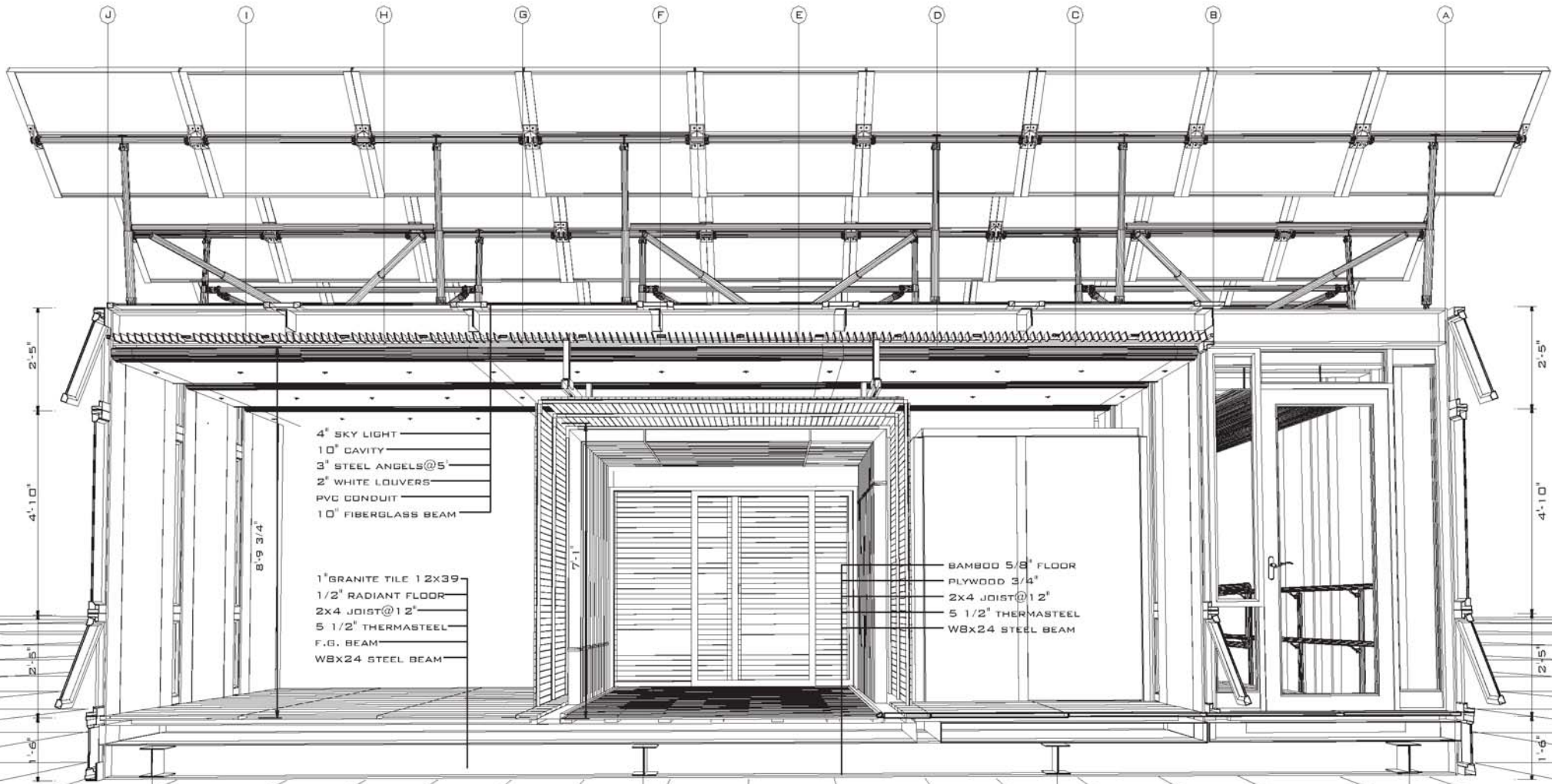

J I H G F E D C B A

2'-5"
4'-10"
2'-5"
1'-6"
8'-9 3/4"
7'-1"
2'-5"
4'-10"
2'-5"
1'-6"

4" SKY LIGHT
10" CAVITY
3" STEEL ANGELS@5"
2" WHITE LOUVERS
PVC CONDUIT
10" FIBERGLASS BEAM

1" GRANITE TILE 12X39
1/2" RADIANT FLOOR
2X4 JOIST@12"
5 1/2" THERMASTEEL
F.G. BEAM
WBX24 STEEL BEAM

BAMBOO 5/8" FLOOR
PLYWOOD 3/4"
2X4 JOIST@12"
5 1/2" THERMASTEEL
WBX24 STEEL BEAM

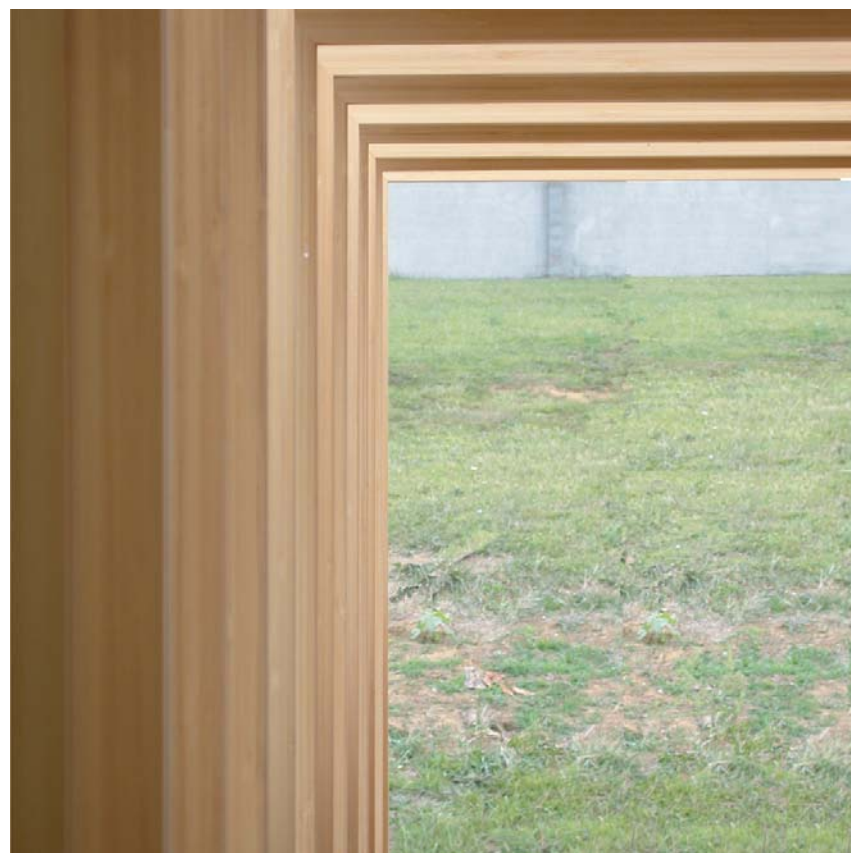

*Left: section c-c, a longitudinal section looking through the bedroom.
Right: day image throughout the bedroom unit: The value intensity
between the bamboo structure and direct sunlight.*

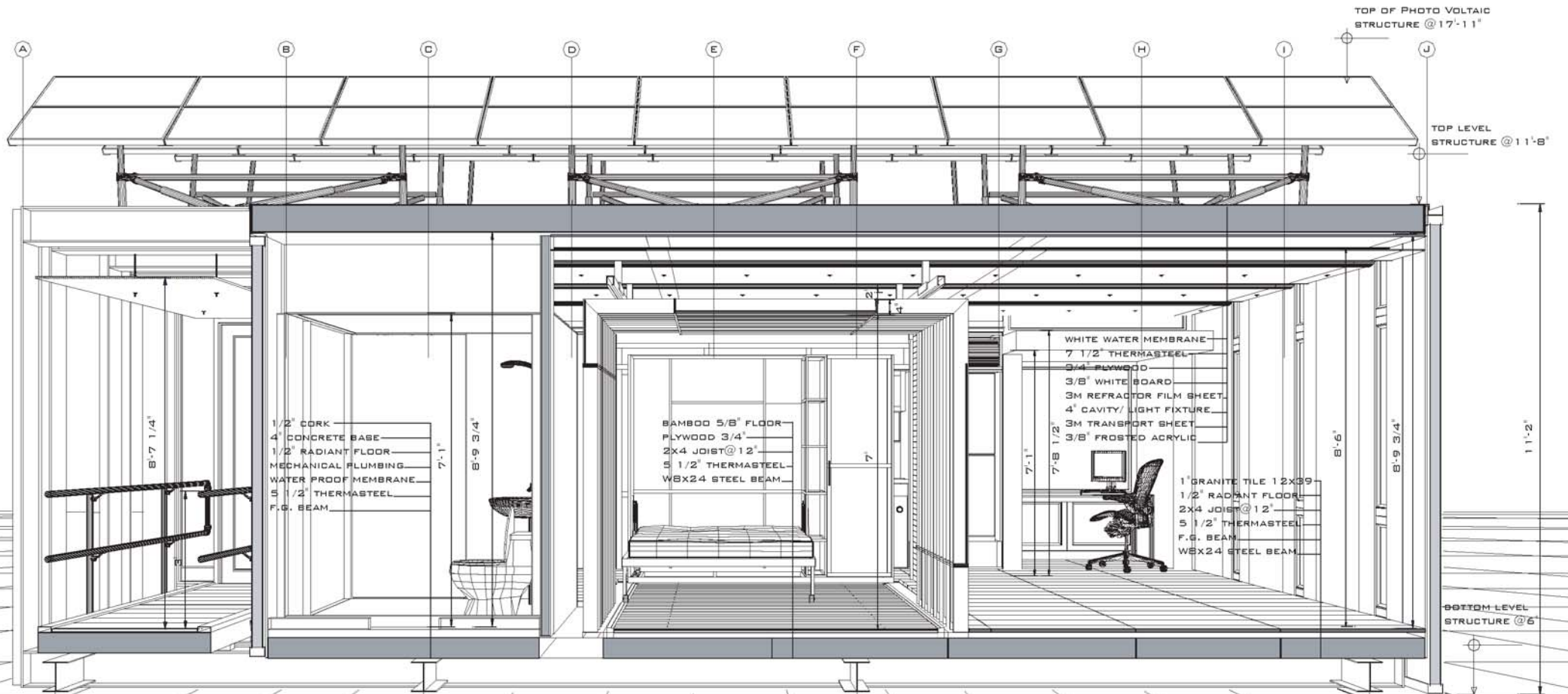

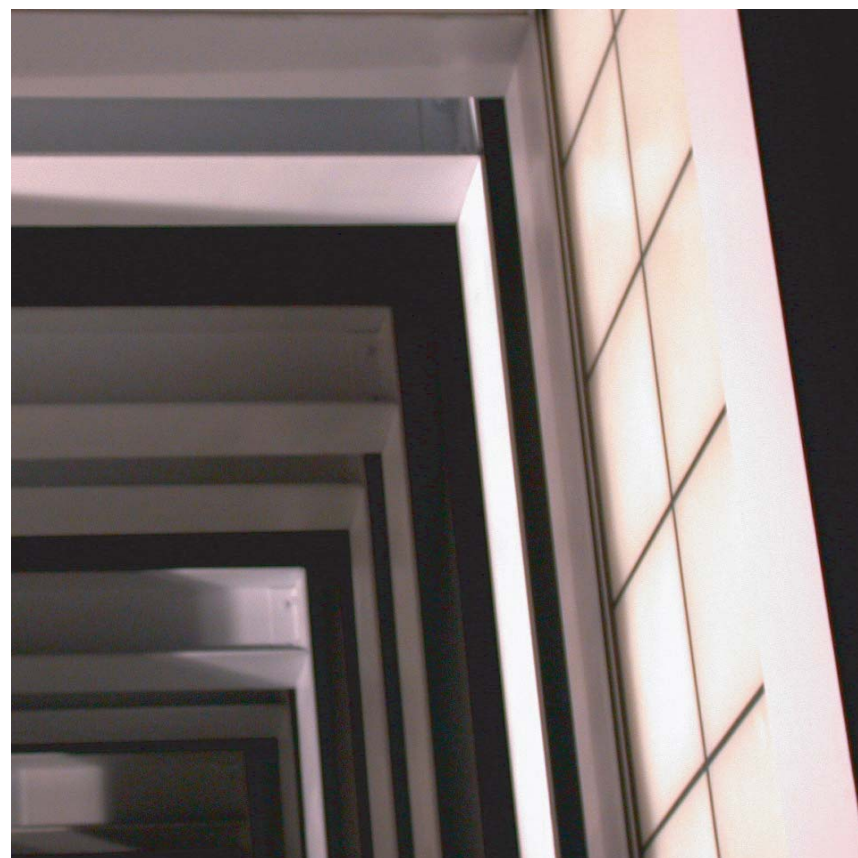

Night interior image: solid and void in the repetitive modular structure reveals as dark and light.

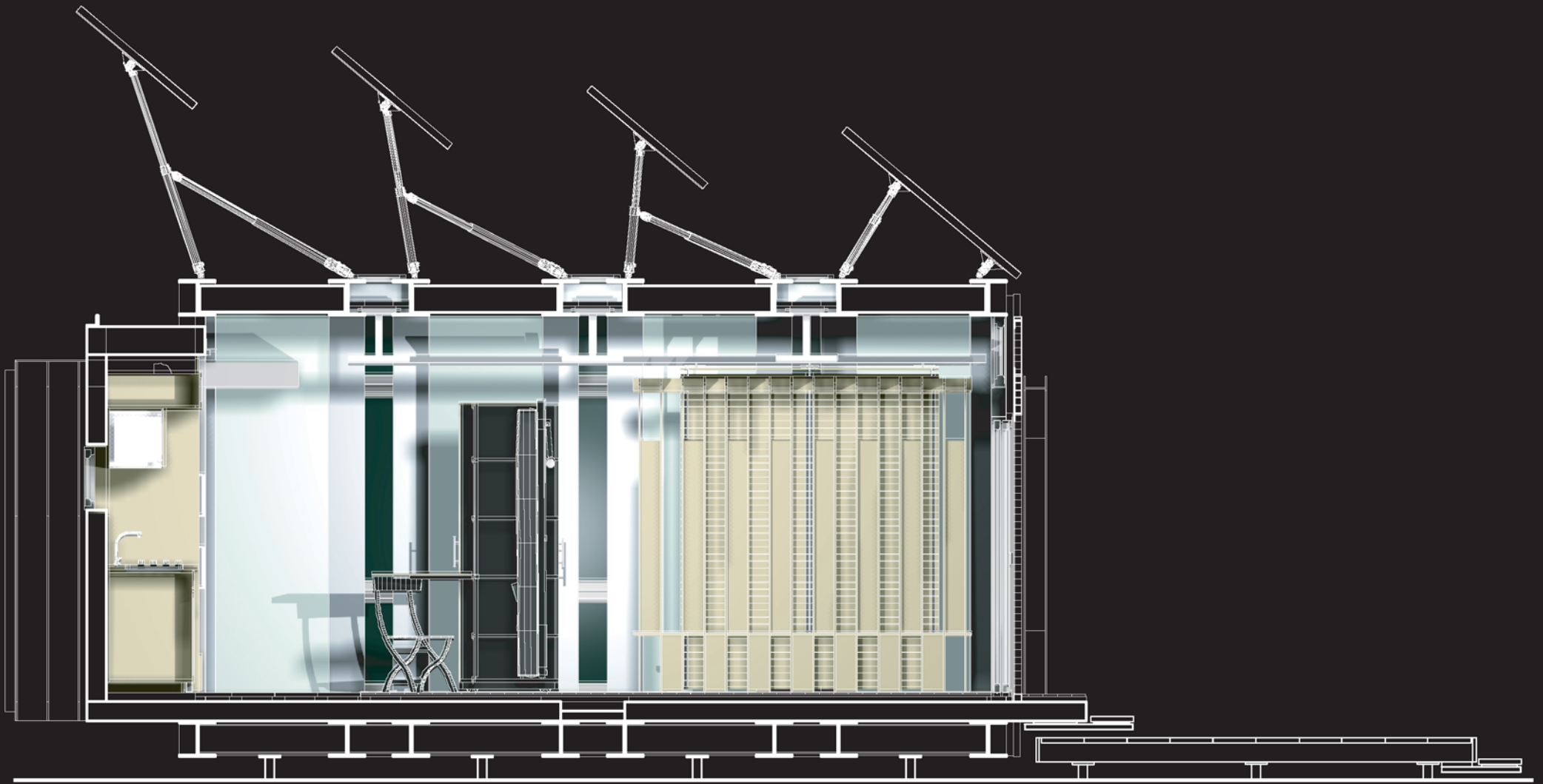

SECTION A-A



SECTION B-B



SECTION C-C

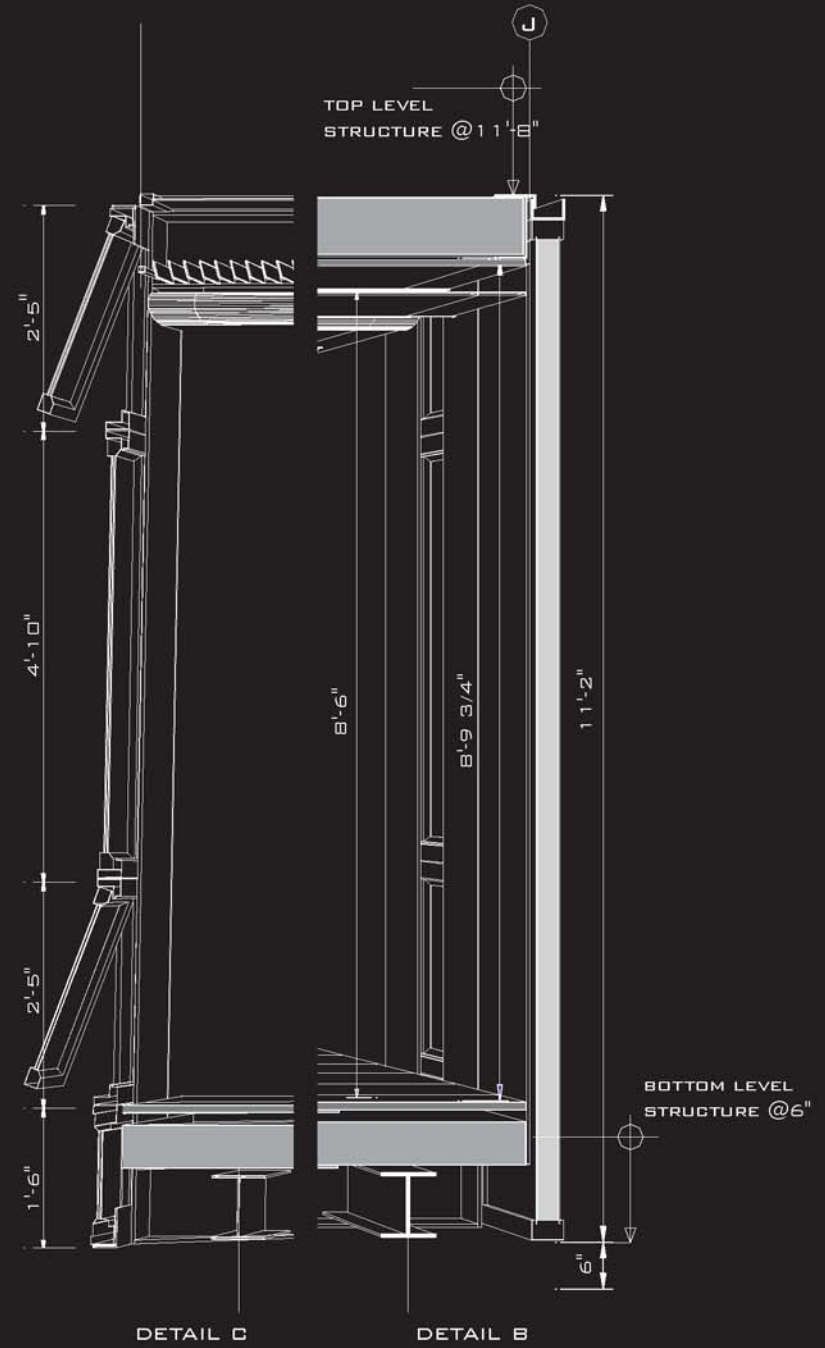

DETAIL C

DETAIL B



DET. D-D

DET. F-F

SECTION D-D

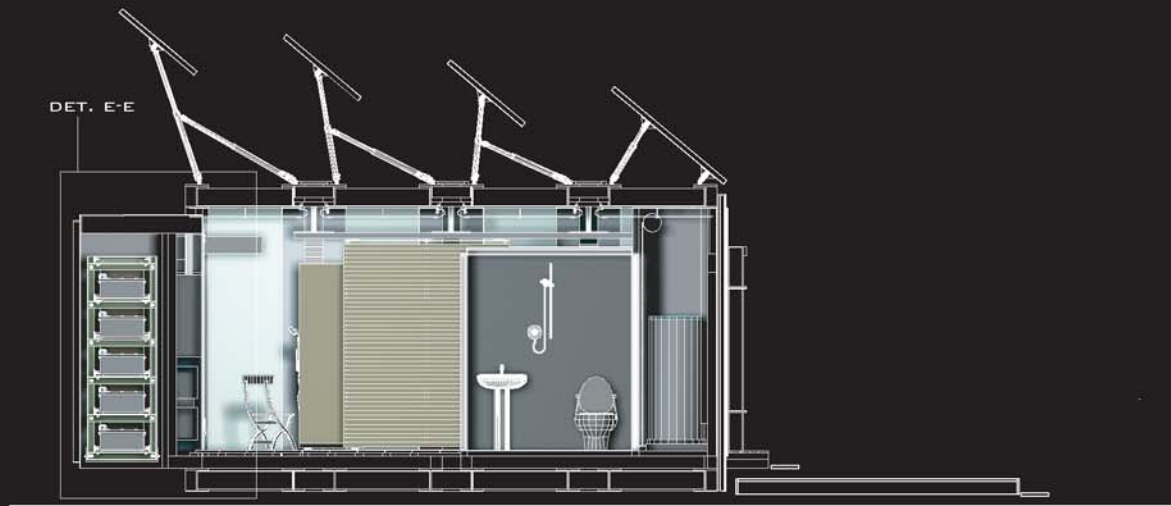

DET. E-E

SECTION E-E

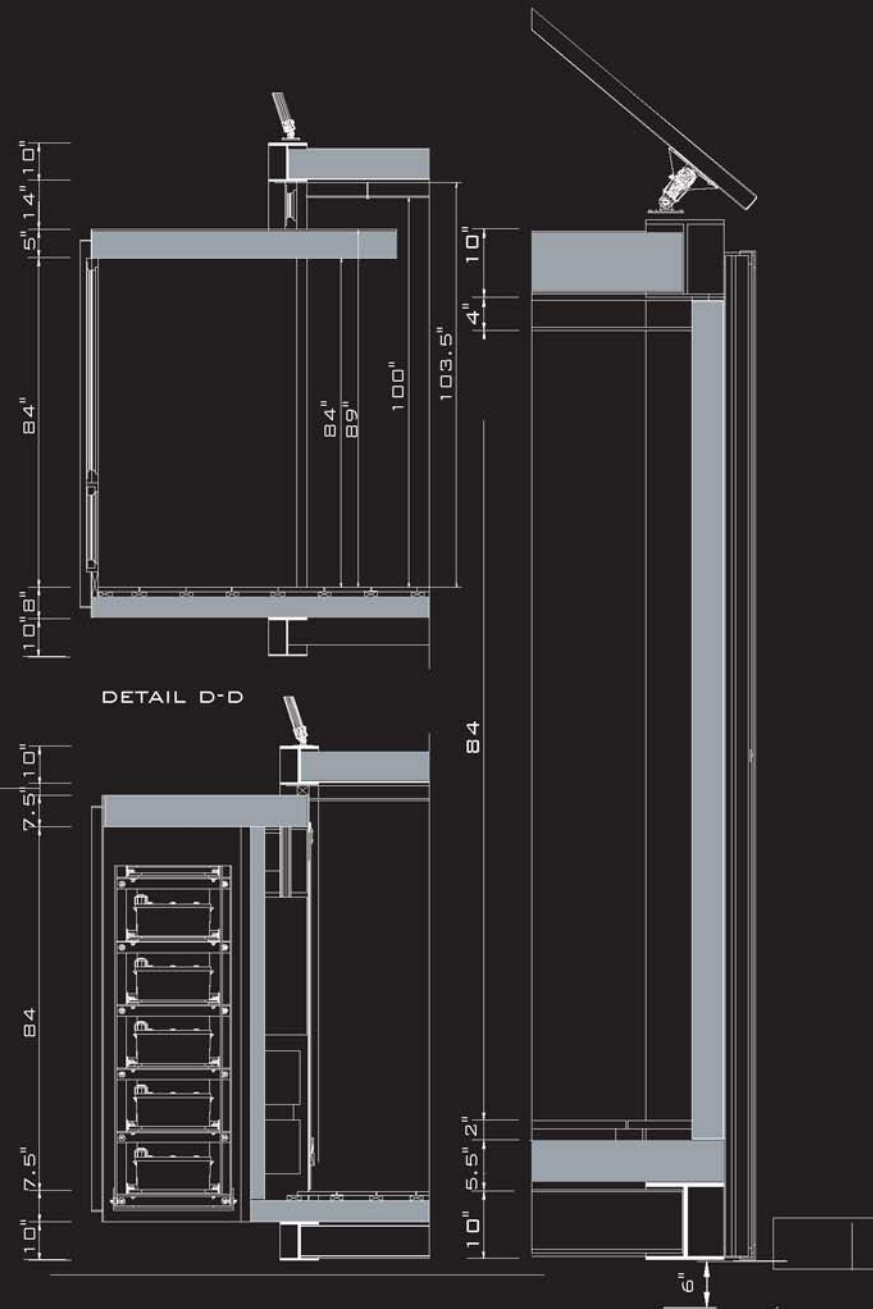

DETAIL D-D

DETAIL E-E

DETAIL F-F

5' 14" 10"
84"
10' 8"

84"
89"
100"

103.5"
4"
10"

3"
7.5" 10"
84"
10' 7.5"

84"
10' 5.5" 2"

6"



Assembly

Opposite: the south module with all the components in it before it was shipped to Washington, D.C.



ROOF

- (3) SELF TAPING SCREWS 1/8"
- 18 LIGHT GAUGE CONNECTION TOP & BOTTOM
- 7.5" THERMASTEEL PANEL (STYROFOAM SLAB + 8 STEEL LIGHT 22 GAUGE)

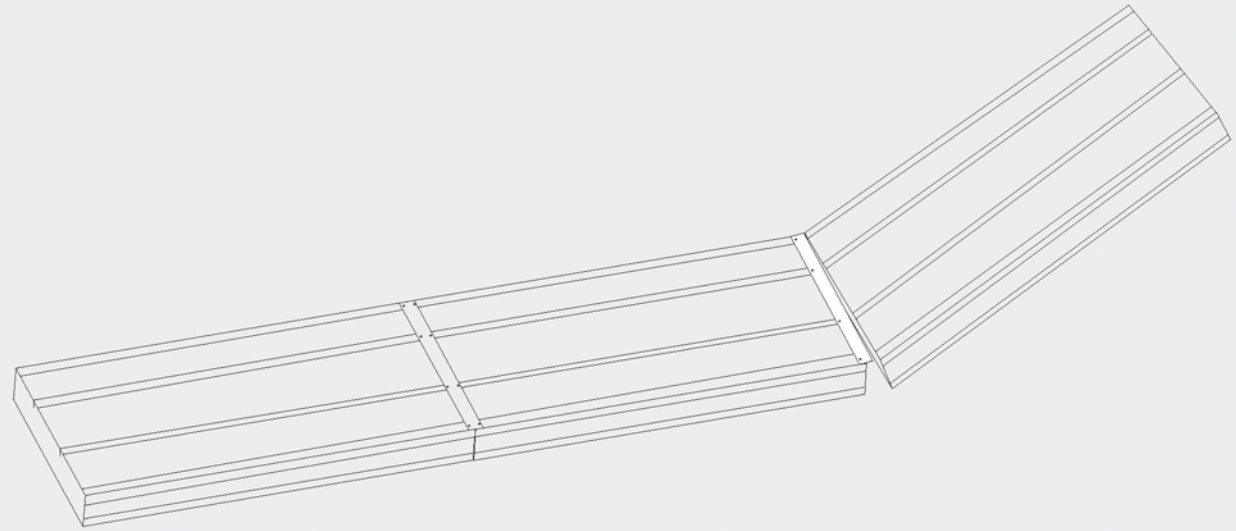
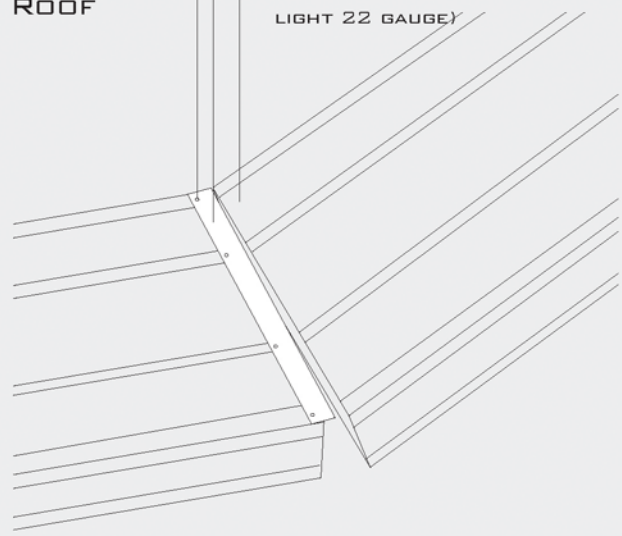

Assembly of the thermasteel slabs

FLOOR

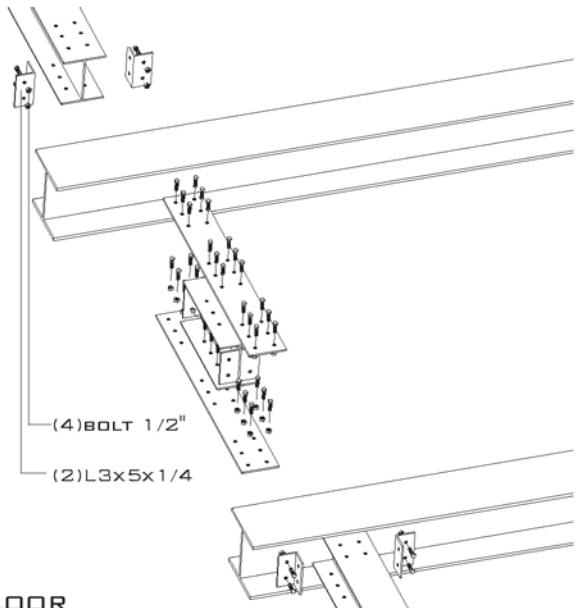

- (4) BOLT 1/2"
- (2) L3x5x1/4

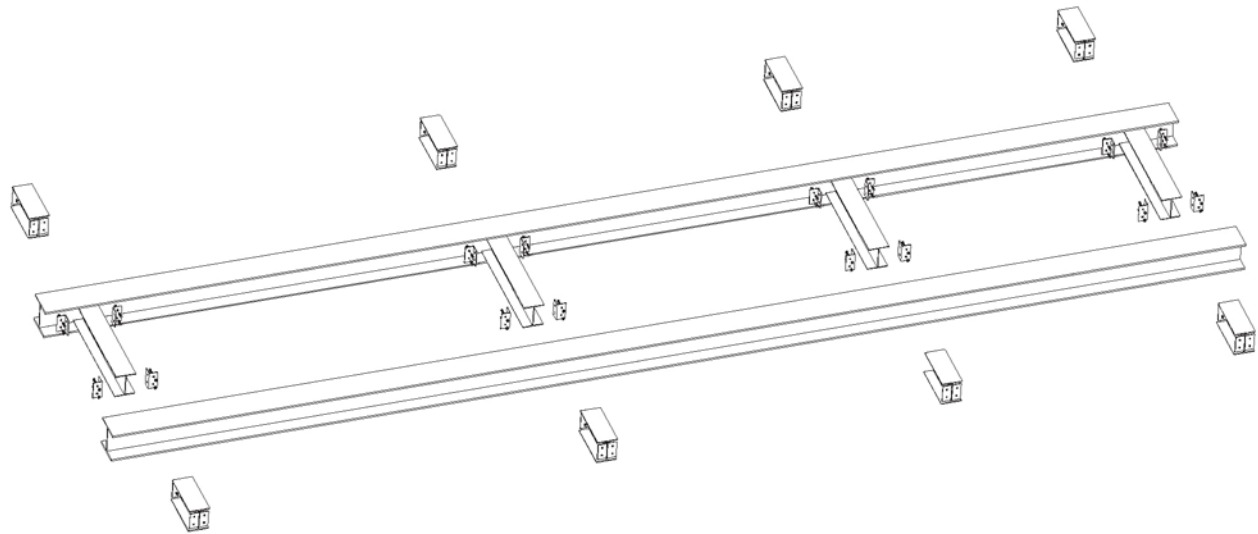

Assembly of the composite ground structure

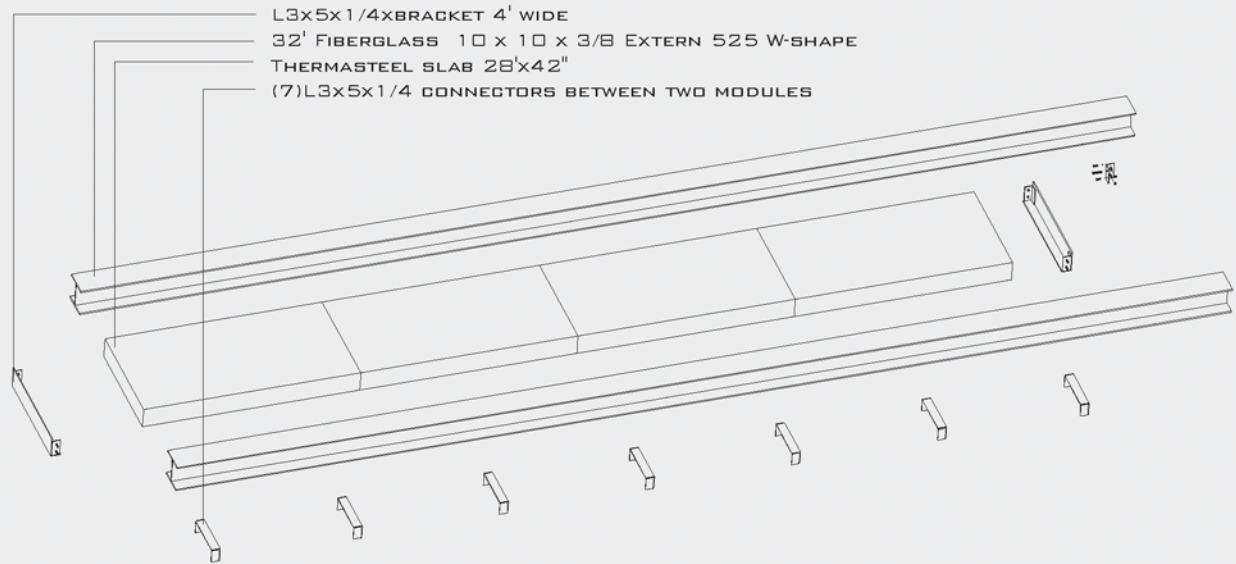
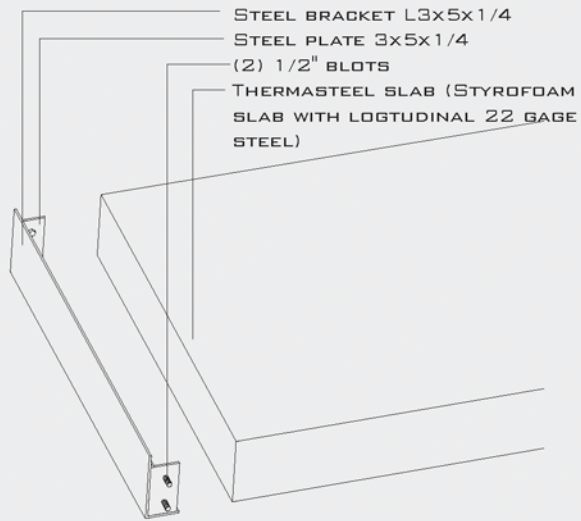

Assembly of the composite roof structure

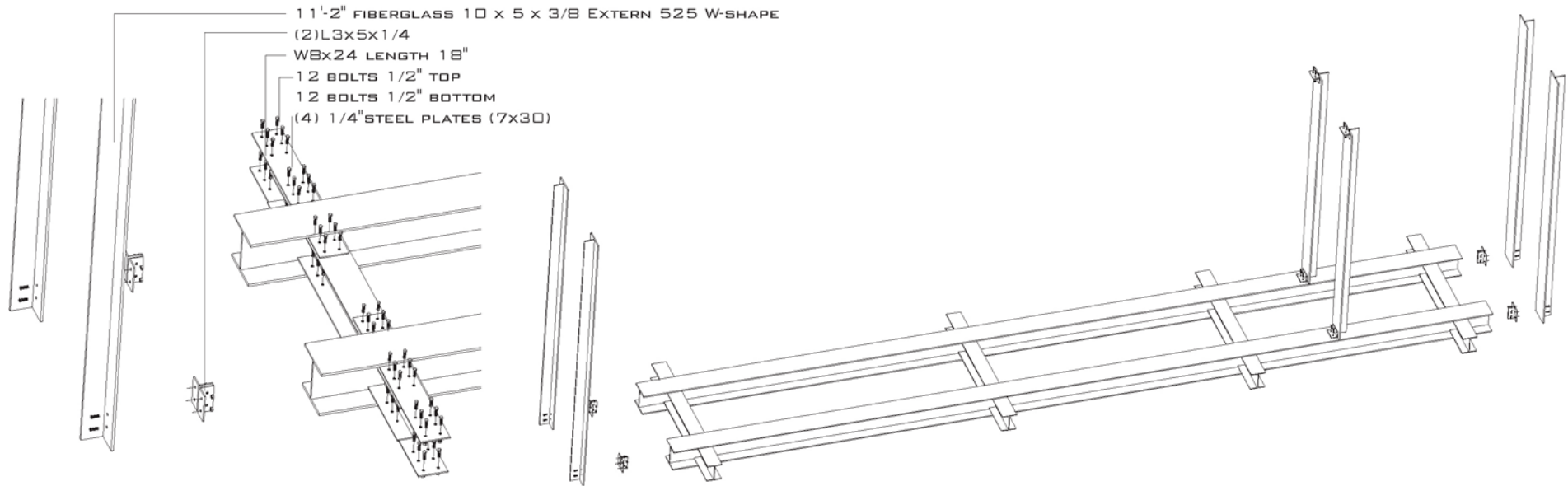

Assembly of the bottom structure with the columns

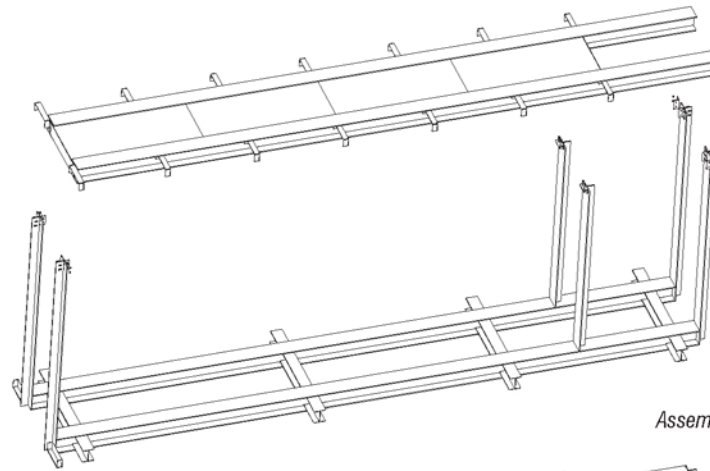
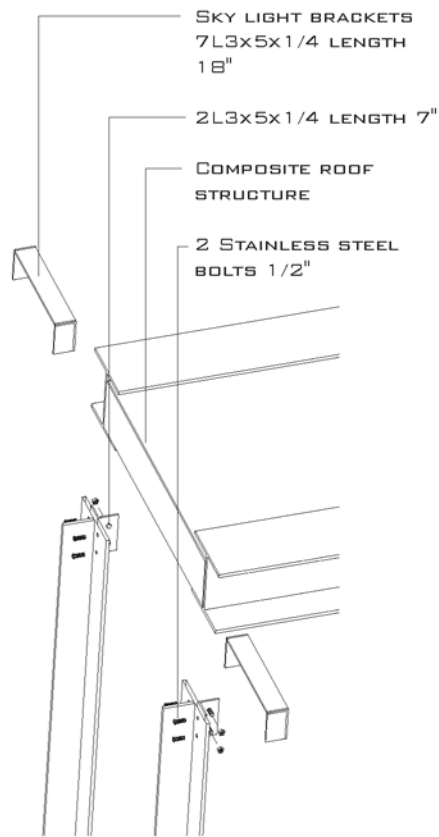

Assembly of roof composite structure to the columns

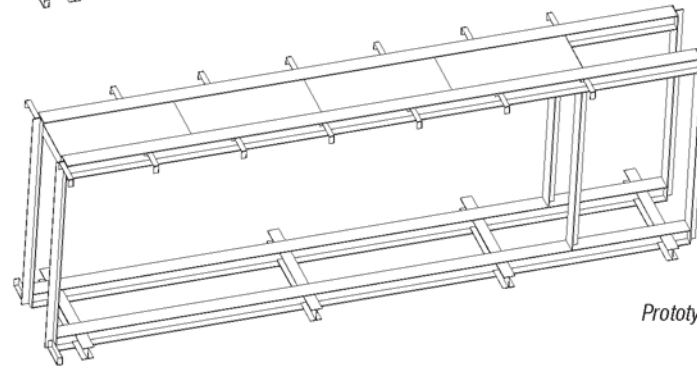

Prototypical non edge module

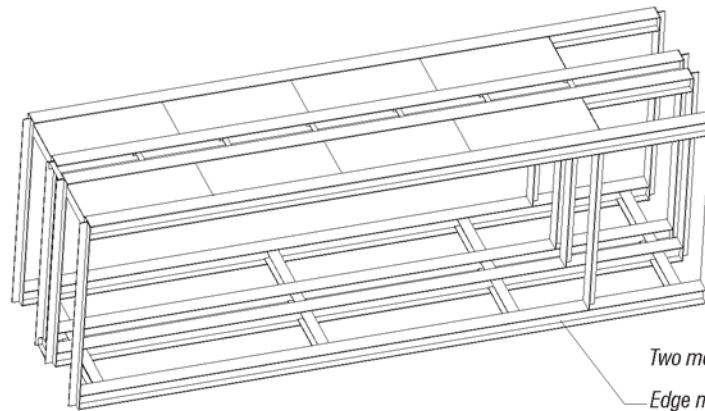

Two modules to fit a truck
Edge modules

*Top left: detail connection of the fiber glass columns to the composite roof structure.
Right: assembly drawing of two modules.*



*Above left: assembly of the first module.
Above right: top joints for adjacent modules.
Bottom right: the joining of the modules.*

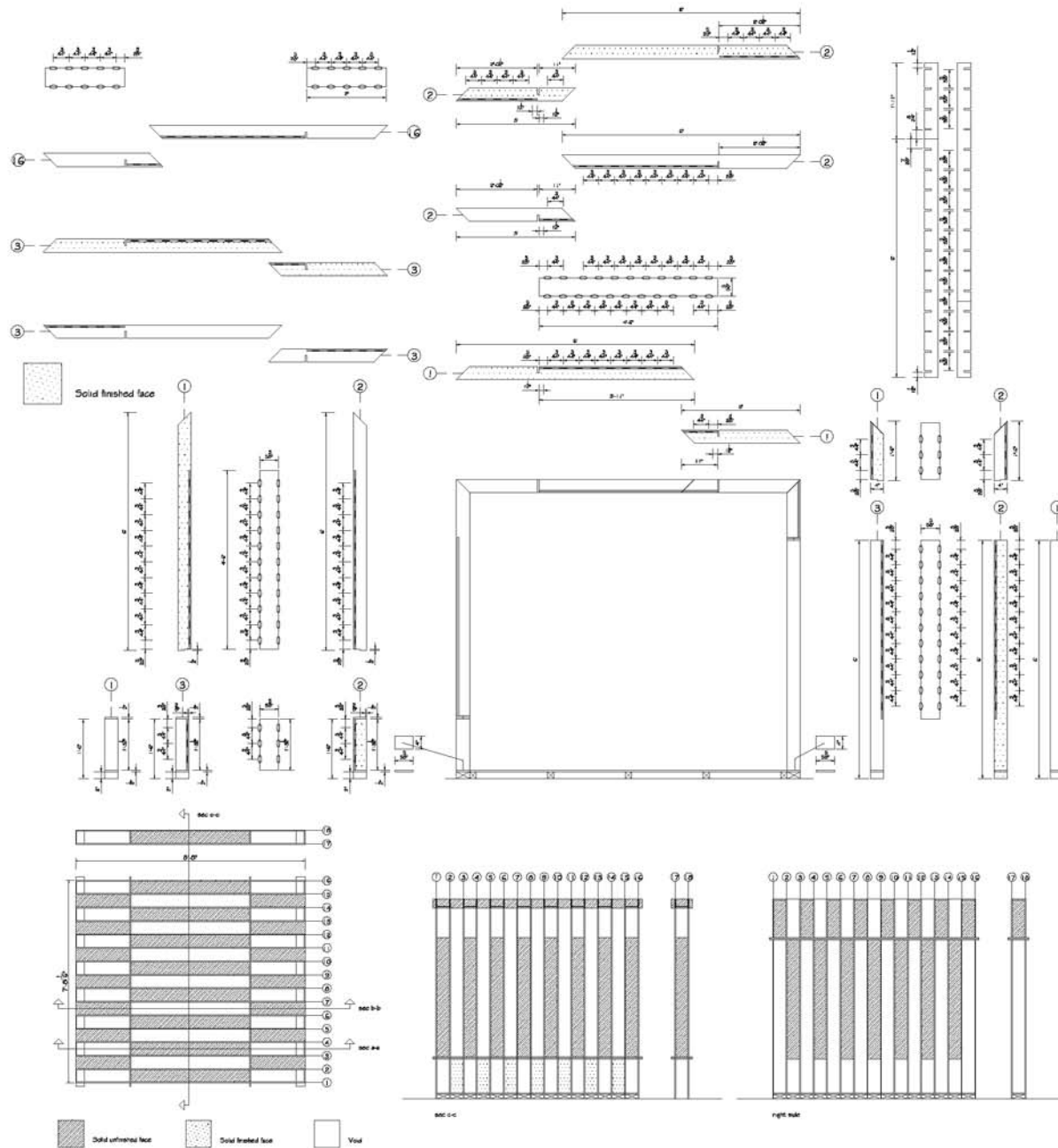

Opposite left: installation of the bamboo stationary unit.
 Opposite Right: images of connecting details of the bedroom unit
 Left: construction drawing of the bamboo stationary structure.



Technology

Opposite: image showing a leaf of a tree and photovoltaic cell, as we imitate the underlying forces of nature.



Systems Integration

Buildings such as the solar house are required to satisfy strict criteria in terms of performance in areas such as thermal and visual comfort. To most efficiently meet these performance mandates a building's structural, mechanical and electrical components must be considered as part of passive and active system solutions. Through the recognition of the three-way interactions between the occupant, climate, and building systems as well as system-to-system interactions, a holistic vision of architecture can be realized. In this way systems integration can be achieved at the highest level.

Systems integration must go beyond physical integration and collision detection. Systems integration must include design that considers simultaneous and delayed interactions. The design operation of one system such as a shading device must be made with understanding of the impact on the cooling system. These interactions are often complex which increases the challenge for optimal systems integration. However without acknowledging such interactions, systems may not work together and may actually work in opposition to each other.

Due to interactive complexities we must rely on the use of advanced computer programs to simulate the outcome during the design process. It is arguable that due to computer tools, design solutions are possible today that were not possible only a few years ago.

Programs such as RISA are based on finite element analysis and were applied to structural design to simulate and predict the behavior of components under different loading conditions.

Such programs allow for study of unconventional materials or conventional materials under unconventional circumstances.

Computational fluid dynamic software were used to simulate forced or natural ventilation, temperature distribution and air flow. Simulations for various days of the year or times of the day were quickly performed. Energy simulation programs such as DOE2 were applied to estimate annual energy consumption and compare alternative systems. Finally interactive 3d visualization tools such as the CAVE allows for experience and 'walk thru' the design before construction.

The incorporation of these tools into the design processes is changing the design paradigm and making systems integration more efficient.

An integrated building is successful when the technological design is the result of technically optimized and honestly expressed solutions. The act of choosing one of those systems decides the material quality, performance factors, dimension, characteristics, and connections to other systems. In other words all the systems have to work together and not to defeat each other in order to reach a total uniform effect .

Buildings, regardless to their size can share the same level of complexity if the same level of performance is required, In other words buildings with the same program but different scales might share the same basic components in terms of systems, but the level of complexity can differ.

As the systems become more interwoven, it is critical to make sure that they work in harmony, for each individually mass-produced system comes with a particular set of requirements and immutable internal logic. Therefore the necessity to have an energy management system (EMS) becomes more important to regulate, operate and orchestrate all the systems in order to ensure integration while the building is in use. EMS functions as a neuron system for the building it is composed of series of sensors, controllers and a computer. The idea is to wire and reach every part of the house through special kind of conduits that are divided to accommodate power, and communication. They run parallel to each other composing a net from floors to walls to ceiling, in order to have access to any point in the house.



Spatial and ergonomic Investigation through the Cave (virtual reality)

PHOTO VOLTAIC SYSTEM

- PHOTO VOLTAIC PANELS 22X44
- STRUCTURE:
- FRAME ALUMINUM L2X2X.25
- ADJUSTABLE ROTATION BEAM STEEL PIPE 1.5"
- TELESCOPING ARM HOLDING BEAM 2"-1.5"
- TELESCOPING TRIANGLE 2"-1.5"
- KEEKLAMP JOINERIES 2"-1.5"
- STEEL PLATE CLAMP HOLDING TO F.G. 5X5X.25

MAIN STRUCTURE SYSTEM

- COMPOSITE STRUCTURE:
- MAIN FRAME
- FIBER GLASS BEAMS WIDE FLANGE 10X10
- FIBER GLASS COLUMNS T SECTIONS 10X5
- STEEL CONNECTIONS W 8X24
- STEEL BRACKET L3X3X.25
- SLAB
- THERMASTEEL PANEL 7.5"
- STAINLESS STEEL BOLTS 1/2"

LIGHTING SYSTEM

- ALUMINUM EXTRUDED PARABOLA
- T8 FLORESCENT LIGHT
- ELECTRINIC BALESTE
- WHITE BOARD REFLECTIVE SURF.
- 3M REFRACTOR SHEET
- CAVITY 4"
- 3M TRANSPORT SHEET
- FROSTED ACRYLIC SHEET 3/8"

CONDUIT SYSTEM

- FLOOR CONDUIT 1.5X4
- POWER/LOW VOLTAGE
- WALL CONDUIT 1X3.5
- POWER/LOW VOLTAGE
- CEILING CONDUIT .5X1
- POWER/LOW VOLTAGE

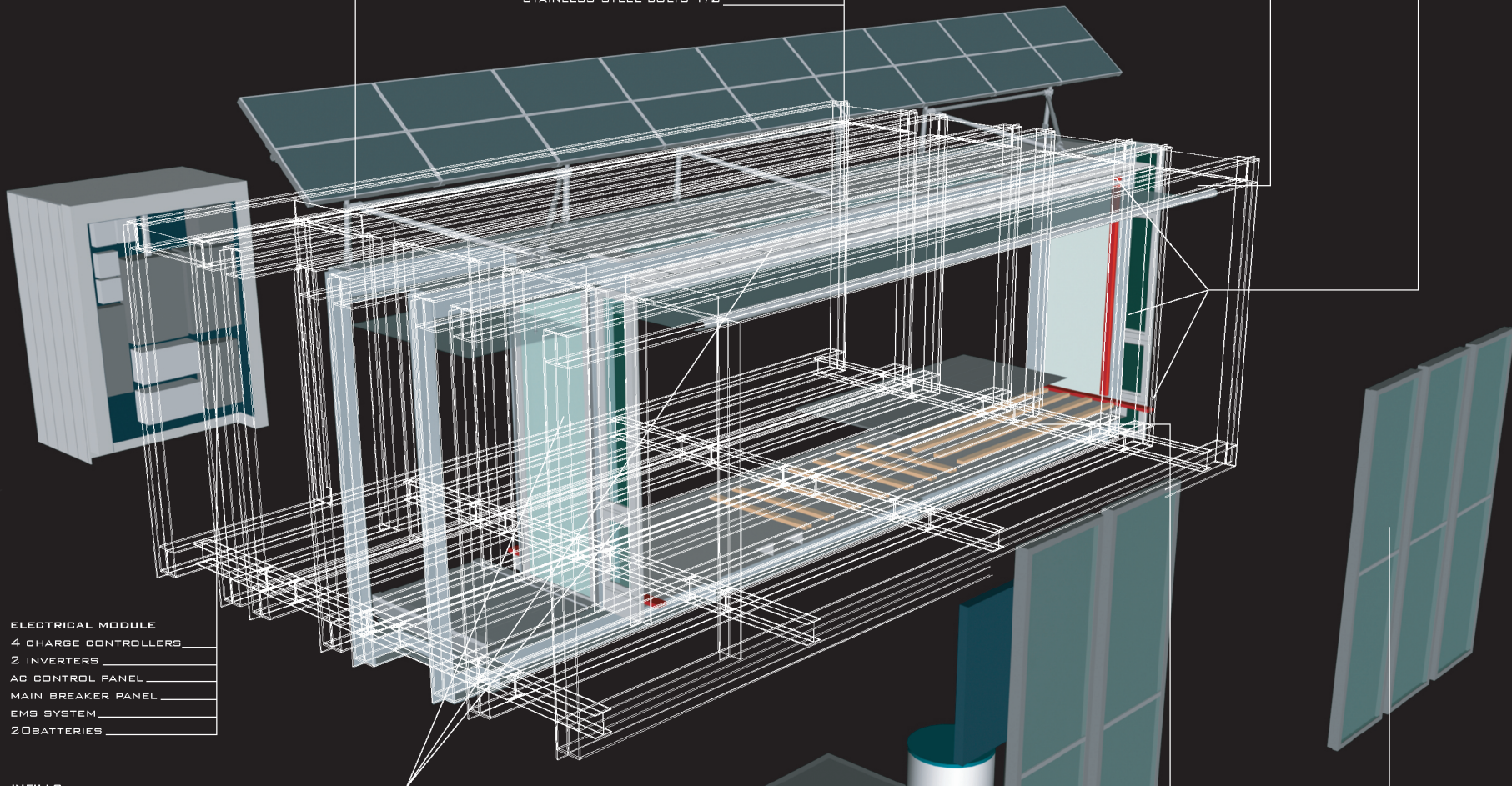

ELECTRICAL MODULE

- 4 CHARGE CONTROLLERS
- 2 INVERTERS
- AC CONTROL PANEL
- MAIN BREAKER PANEL
- EMS SYSTEM
- 20 BATTERIES

INFILLS

- WALLS
- ALUMINUM FRAME 4X11-2
- WHITE ACRYLIC SHEET
- ALUMINUM GRID 24X24
- AIRGEL INFILL 2.5"
- SKYLIGHT
- 5 PREFAB SKYLIGHTS 1-6X5
- PANELS INFILL 18X18
- ALUMINUM SHEET CLADDING
- WINDOWS
- VERTICAL SWING 18X28
- HORIZONTAL SWING 18X56
- VERTICAL SWING 18X28

MECHANICAL MODULE

- TWO HOT WATER TANKS 28"X5"
- HOT WATER PUMP
- AIR TO AIR EXCHANGER
- REGULATOR

FLOOR SYSTEM

- GRANITE TILES 39X12
- STUDS SPACERS 2X4
- RADIANT FLOOR PIPES 1" @ 9"
- REFLECTIVE ALUMINUM FOIL
- THERMASTEEL SLAB 5.5"

THERMAL PANELS

- THERMAL PIPES 1 1/2" X 3/8"
- CLEAR LOW IRON GLASS
- FIBER GLASS FRAME 04X2
- INSULATION 2"
- PLYWOOD BACK 1/2"



From the beginning the conception was to design and build a house that could fully sustain itself in terms of energy use. The house contains all required appliances such as stove, washer, dryer, heating and cooling and hot water heater. Knowing the electrical demand of these appliances enables us to determine how much energy we need to harness from the sun. This calculation must take into consideration the sun angle and intensity as it changes throughout the year. In this instance the electrical demand was determined to be 6 kilo watts per day. Through studying the sundial we based our calculations on the worst case scenario corresponding to the months of December and January with the lowest sun angle 31 degrees at noon and 15 degrees at 10:00 am and 3:00 pm.

Similar to the chloroform process in the leaf on a tree, the photovoltaic cell absorbs the sun's energy and converts it to a useful energy form, electricity. The electricity can be used directly, through DC appliances, or stored in batteries for later consumption.

Fundamentally the leaf and photovoltaic cell operate with the same obligation to the sun's radiation. In recognition of this obligation the photovoltaic array were liberated from the main structure, allowing them to move and track the sun's position. Through observation nature reveals itself, and through models, drawings and computer simulations such revelations were applied to this project. The structural mechanism starts revealing itself in how it wants to be, as mediation between the static and the dynamic trackable panel.

Sizing the PV system required that there was enough energy for storage or reserve. Minimizing the energy losses through correct wiring and minimizing the distance from the source to the batteries and from the batteries to the inverters and then to the appliances, required that the battery rack and the other the components be built on to the same structure (The utility core unit).

*Opposite: image of the photovoltaic panels on the house supported by the transformable structure.
Bottom right: 3d computer generated study model for sun shading to be able to determine when full exposure occurs and on which row during critical months like December, January, and February.*



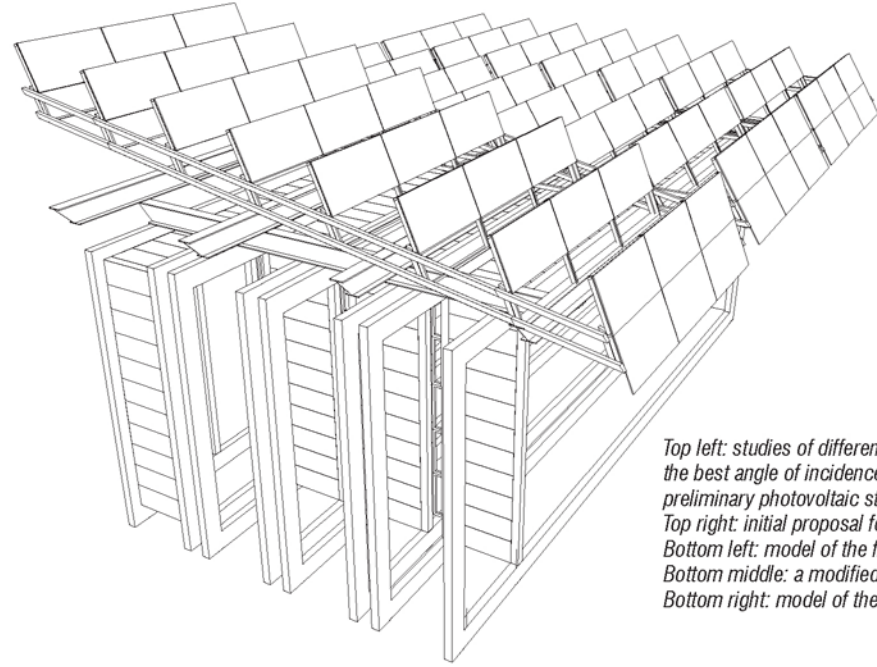
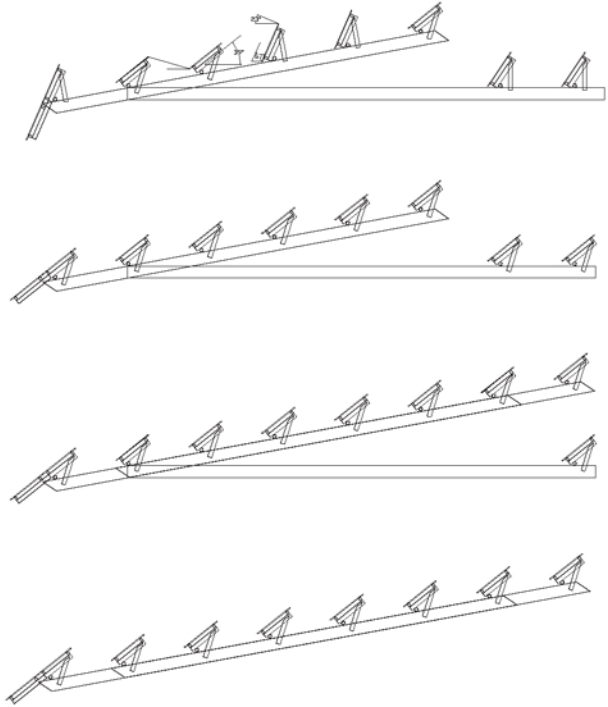

Top left: studies of different configurations on the PV panels to determine the best angle of incidence and an acceptable shading angle for the preliminary photovoltaic structure.
 Top right: initial proposal for the photovoltaic assembly.
 Bottom left: model of the first photovoltaic structure.
 Bottom middle: a modified model of the first proposal.
 Bottom right: model of the second alteration of the photovoltaic structure.

Phase 1

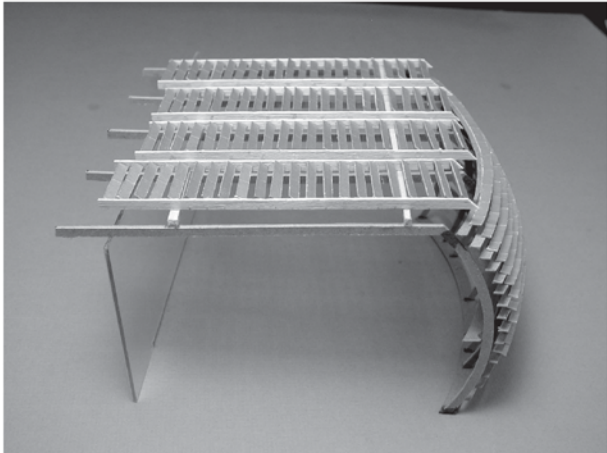
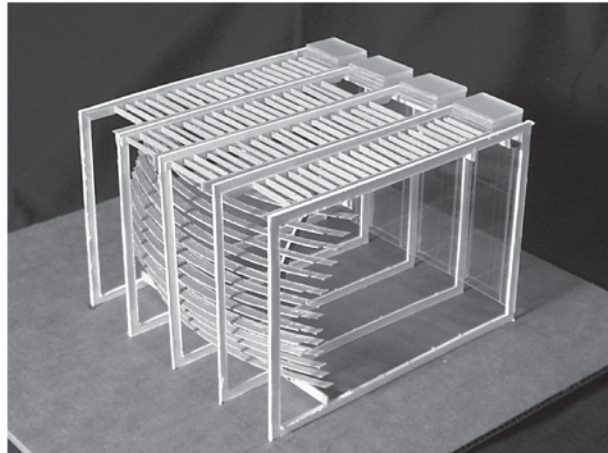

Phase 2

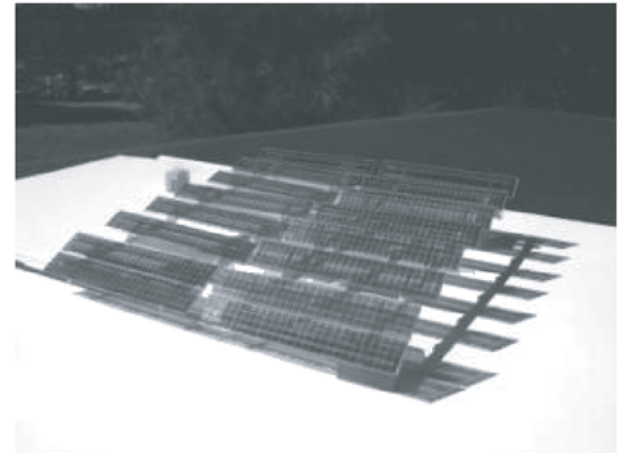

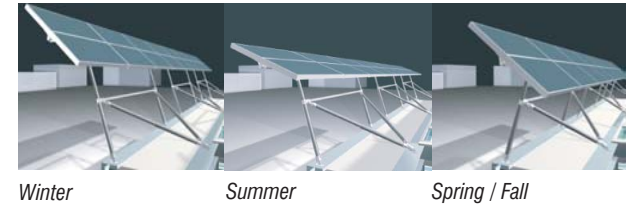
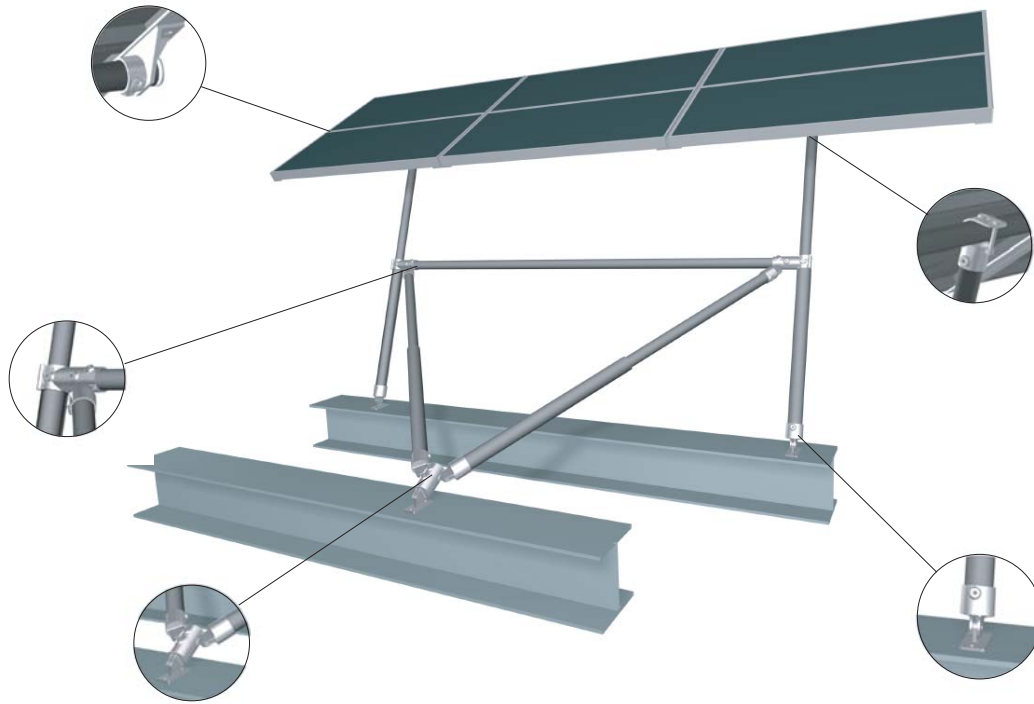

*Top right: transformation of photovoltaic structure to track the sun.
 Left: 3d drawing of the photovoltaic structure using special joints.
 Bottom left: study model of the photovoltaic modular structure.
 Bottom middle: prototype of the modular photovoltaic structure.
 Bottom right: view of the roof with all the photovoltaic modules in place.*

Phase 3

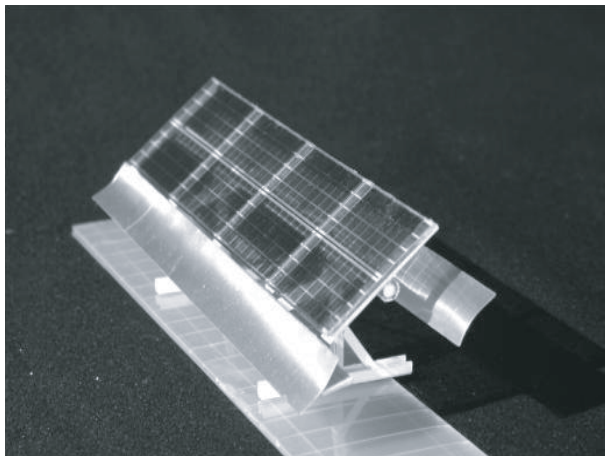

Phase 4



Structure / Materials

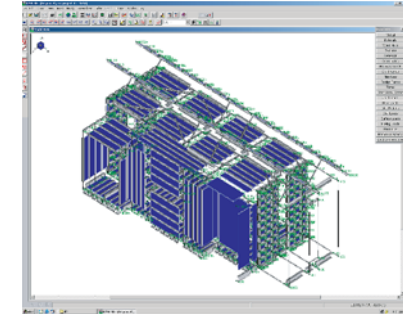

69

The solar house presented opportunities to use unconventional materials such as aerogel. This material is super-insulating, using 2" of translucent aerogel, we were able to get 10% of the natural daylight into the space and an R value of 20 ft².F.h/Btu.

Thermal bridging between inside and out was a concern for the structural system. With this in mind, there was a conscious decision made to use fiberglass instead of steel due to its lightweight and low conductivity. A series of computer analysis and physical testing were conducted to satisfy the structural requirements.

Top right: structural analysis on fiberglass I-beams done through finite analysis software using RISA3d.

Right: view of the back corner of the house showing fiberglass structure and aerogel panels.

Bottom left: aerogel particle.

Bottom middle: deflection Testing the composite structure through gradual loading.

Bottom right: unloading the two structural modules from the trucks and fixing them on site.



Lighting

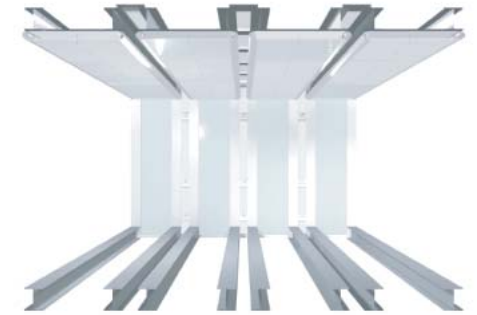

The lighting system had to be energy efficient, uniformly distributed and shallow in section. For this purpose an experimental film composite from 3M was utilized in the design of the artificial lighting system. The system included a transport and refractor. Light is carried evenly over a given area, dispersed from the ceiling as snow falling through the space. The quality and quantity of ambient light is achieved through a limited number of standard fluorescent lamps 32 watt thus significantly reducing energy load of the space.

- Top left: 3d model of the lighting system.*
- Right: image of the ambient lighting using the refractor sheet.*
- Bottom left: integration of natural lighting with electrical lighting as the daylight passes through the skylight and window.*
- Bottom middle: installation of the system.*
- Bottom right: image of acrylic sheet along with two parabolas between the skylight.*



Natural Ventilation

71

Due to the large south-facing windows solar houses have the tendency to overheat, during winter days with moderate outdoor temperatures. Natural ventilation can alleviate this condition. Accordingly a series of studies were performed on physical and computer generated models using software designed for fluid dynamic analysis.

To optimize the ventilation effectiveness a number of alterations for the window location and sizing were studied. The resulting configuration maintained comfort conditions with good airflow especially on hot summer days, by having the gaps between the modules that are oriented east and west operable in different ways.

Top right: natural ventilation studies through computer simulation program using CFD.

Right: view of the east wall showing the windows opened for air circulation.

Bottom: natural ventilation schemes for air flow.

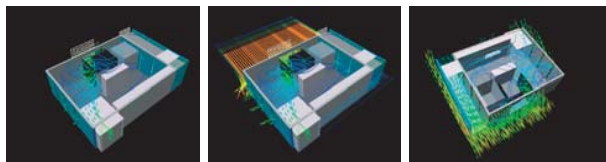
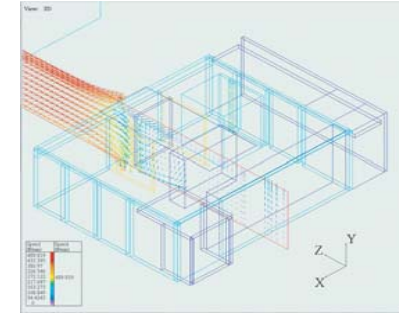

Solar Thermal



The solar thermal system collects solar radiation and converts it to a usable form of heat. Five flat plate panel collectors, with water and propylene filled copper tubes, are mounted in a vertical position on the south wall. Solar radiation passes through a layer of PPG Solar Fire glass and is absorbed by the black-painted tubes. The circulating water transfers the heat to two 80-gal storage tanks for heating the potable water and for shower and appliances. The solar thermal system also provides radiant heating through the floor. Water temperatures in excess of 120°F are achievable during clear sky condition.

*Top: 3d model of the house showing radiant floor.
Right: view of the upper east corner showing thermal panels, PV panels, and structure.
Bottom left: 3d model showing the thermal south wall and radiant floor.
Bottom middle: radiant floor with granite tiles for thermal storage.
Bottom right: custom made thermal panels under construction.*



Postscript

Opposite: (board exhibit) image of the Virginia Tech setting for the Solar house furniture at the ICFE in New York 2003.

ICFF Editors Award Best Design School
VIRGINIA TECH INDUSTRIAL DESIGN



Evolved Ideas

75

The solar house started out with a simple idea. In time this idea took shape, body became more complex. Many ideas came to surface, in order to make the house as a whole. Those ideas evolved, developed and were transformed for different purposes.

The moving closet that works as a divider has the Murphy bed on one side, a dining table on the other, along with the ability for adjustment. This idea fits the purpose of houses with minimal space, such as New York apartments.

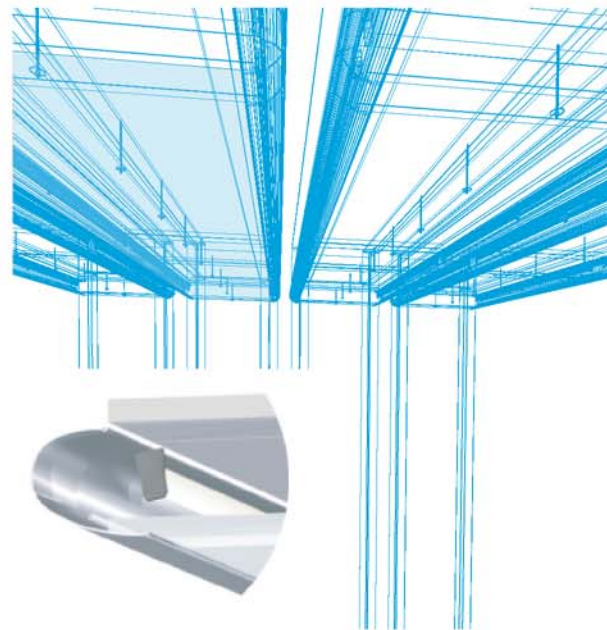

An experimental film composite from 3M was utilized in the design of the artificial lighting system. Utilizing a transport and refractor sandwich, light is carried evenly over a given area, dispersed from the ceiling as snow falling through the space. The quality and quantity of ambient light is achieved through a limited number of standard fluorescent bulbs, thus significantly reducing the energy load of the space.

Modular Instructional Laboratory



Making an open space composed of individual modules carrying all the technological systems (ambient lighting, radiant floor, photovoltaic panels, and the conduit channel system) generated new initiatives. One was a modular transportable lab taking advantage of the structure's flexibility, and the ability to insert and remove other systems in order to make it compatible for other functions.

The lab equipment might be reconfigured to support more than one pedagogical model or more than one science-related subject. Additionally, the number of middle modules can vary from one to several units, providing a means to alter the classroom size to achieve a high level of systems integration (structure, enclosure, heating, cooling, ventilation, lighting, etc.) and to implement a close-packing strategy for these systems within the modules.

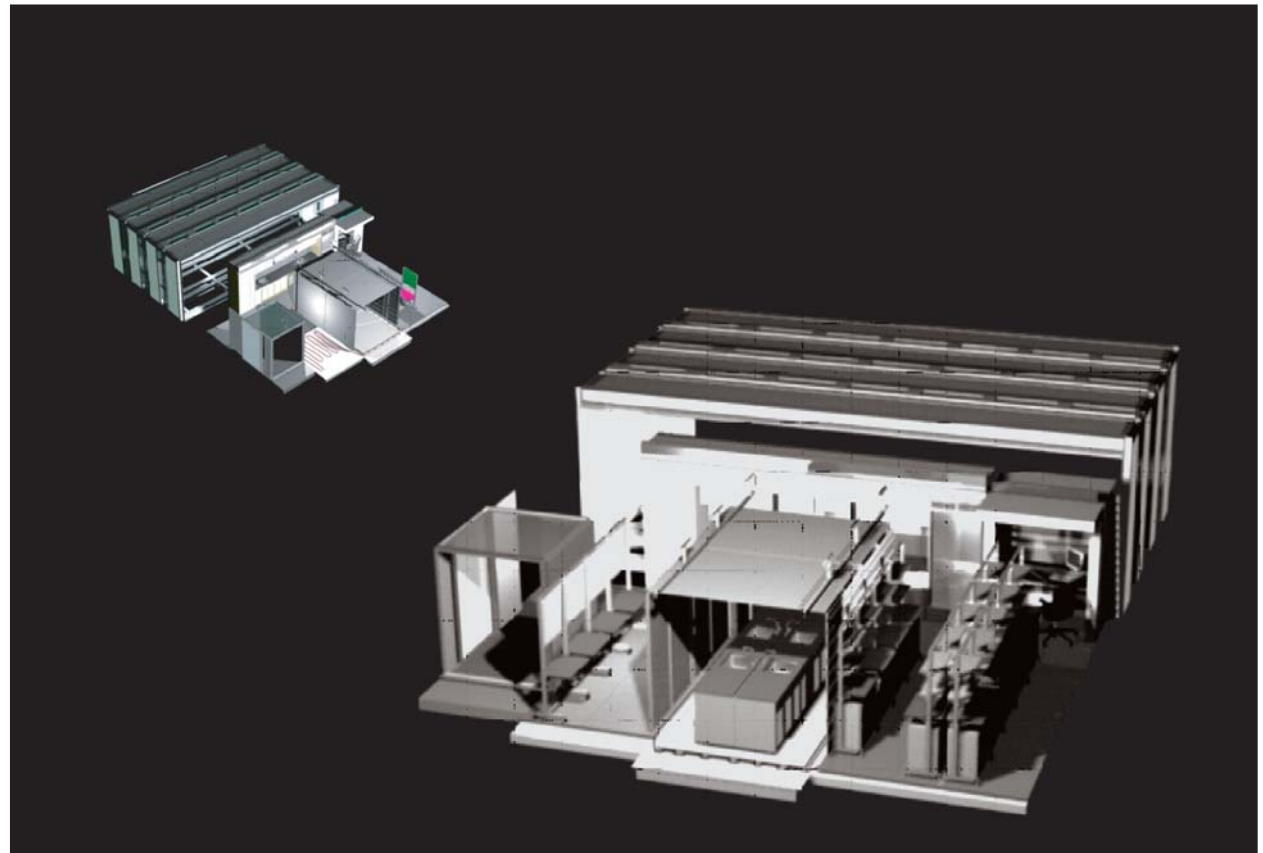

*Top right: image of the modular envelope system being shipped.
Right: two computer generated models showing the dry and wet lab as inserts.*

Acknowledgements

I would first like to thank my mother and father, Nadia, aunt Olga, uncle Naim, aunt Nadima, uncle Yousef, and aunt Salwa for their encouragements and constant support.

I would like to thank my committee for their guidance, knowledge, and patience. It has been a pleasure to learn from each one first hand. I would also extend my thanks to Prof. Robert Schubert, Prof. Michael O'Brien, Prof. William Galloway, Ellen Braaten, Heinrich Schnoedt, Joe Wheeler, Matt Lutz, Henry Hollander and to all the Professors and faculty who were involved in this project.

I would like to thank my friends in the Solar Decathlon team who were with me daily: Chonlaporn (Tin) for all her support and creative efforts in the drawings, presentation and simulation, Greg Morris whom I consider as a brother, and without his support I would not have made it through, Aaron Amons, David Miller, John Rozada, Ross Marks, Jasson Kovak, Aaron Alan, Jun, Jasson Miller, Stefany and also to all the people who helped in making this project to come to reality especially to the staff in the metal, and woodshop: Bill, John, Buddy, and Tim.

Last but not least, I would also like to thank my friends who were with me at the studio: Dawn, Andria, Kelly, Sari, Daniella, Ahmad, George, Becky, Halil, Chris, Ryan, Phil, Ceca, and Sara.

Bibliography

Finite and Infinite games

Carse, James P. 1986 Free Press

Living for Tomorrow

Metropolis, Issue: December 2002 by Hall, Peter

Oskuldens Arhundrade: Den Vita Monokromens Historia

Century of Innocence: the History of the White Monochrome

Publisher: Malmö, Sweden, Rooseum, Stockholm

Liljevalchs Konsthall 2000

In The Praise Of Shadows

Tanisaki, Junichiro

Leet's Island Books, 1977

Integrated buildings: The systems Basis of Architecture

Leonard R. Bachman

Publisher: New York: J. Wiley sons, c2003

Tadao Ando's Movie

Vedio Recording 1989: executive producer, Peter Brugger;
produced & directed by Michel Blackwood; coproduction, Michael
Blackwood Productions.

Saarlandischer Rundfunk Publisher New York, NY : Michael

Blackwood production 1989

Living in motion: Design and Architecture for Flexible Dwelling

Edited by Mathias Schwartz-Clauss, Alexander Von

Publisher Weil Am Rhien: Vitra Design Museum 2002

Credits

All images are by the author or the Virginia Tech Solar Decathlon Team or from the public domain.

Vita

79

Yousef Nawas

Bachelor in Architecture □ 1996

Master of Architecture □ 2004