

NSTSCCE

National Surface Transportation
Safety Center for Excellence

Quiet Car Detectability

Impact of Artificial Noise on Ability of
Pedestrians to Safely Detect
Approaching Electric Vehicles

Luke Neurauter, Michael Roan, Miao Song,
Marty Miller, Eric Glenn, and Jacob Walters

Submitted: April 10, 2020

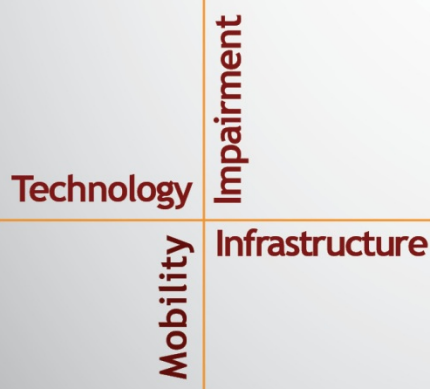

ACKNOWLEDGMENTS

The authors of this report would like to acknowledge the support of the stakeholders of the National Surface Transportation Safety Center for Excellence (NSTSCE): Tom Dingus from the Virginia Tech Transportation Institute; John Capp from General Motors Corporation; Chris Hayes from Travelers Insurance; Terri Hallquist and Nicole Michel from the Federal Motor Carrier Safety Administration; Cathy McGhee from the Virginia Department of Transportation and the Virginia Transportation Research Council; and Jane Terry from the National Safety Council.

The NSTSCE stakeholders have jointly funded this research for the purpose of developing and disseminating advanced transportation safety techniques and innovations.

TABLE OF CONTENTS

LIST OF FIGURES.....	iii
LIST OF TABLES.....	vii
LIST OF ABBREVIATIONS AND SYMBOLS	ix
CHAPTER 1. INTRODUCTION.....	1
CHAPTER 2. METHODS	3
OVERVIEW.....	3
TEST SITE	3
VEHICLE NOISE TESTING	4
<i>Test Vehicle and Additive Sound Conditions</i>	6
<i>Data Acquisition and Analysis System</i>	7
<i>Background Noise</i>	9
<i>Noise Measurement Results</i>	9
<i>Dynamic Measurement Results for 10 and 20 km/h</i>	12
LISTENER TESTING	15
<i>Study Design</i>	15
<i>Study Schedule and Procedure</i>	16
<i>Participants</i>	17
<i>Test Site Arrangement</i>	19
<i>Instrumentation</i>	21
<i>Dependent Measures</i>	28
CHAPTER 3. RESULTS.....	29
DETECTION BY SOUND CONDITION AND APPROACH WITH 55-DBA BACKGROUND NOISE	30
DETECTION BY SOUND CONDITION AND APPROACH WITH 60-DBA BACKGROUND NOISE	37
SAFE TO CROSS (RECOGNITION OF STOPPED VEHICLE).....	42
POST-DRIVE QUESTIONNAIRE.....	45
CHAPTER 4. CONCLUSIONS	51
CLOSING THOUGHTS	52
APPENDIX A. PHONE SCREENING QUESTIONNAIRE	53
APPENDIX B. INFORMED CONSENT FORM	59
APPENDIX C. PRE-DRIVE QUESTIONNAIRE.....	63
APPENDIX D. HEARING FORM.....	65
APPENDIX E. HEARING TEST RESULTS.....	67
APPENDIX F. INITIAL OVERVIEW PROVIDED TO PARTICIPANTS	71
APPENDIX G. TEST SITE OVERVIEW PROVIDED TO PARTICIPANTS	75
APPENDIX H. POST-DRIVE QUESTIONNAIRE	79
REFERENCES	81

LIST OF FIGURES

Figure 1. Satellite map. Virginia Smart Road test site (Source: Google Maps).....	3
Figure 2. Photo. Smart Road asphalt surface at test site.	4
Figure 3. Diagrams. Stationary (left) and dynamic (right) testing diagrams from FMVSS 141 testing procedures.	5
Figure 4. Photos. 2018 Chevrolet Bolt and front speaker mount.	6
Figure 5. Photos. Modified front speaker mount.	7
Figure 6. Photo diagram. Hardware and software used for acoustic measurements.....	8
Figure 7. Diagram. Labview block diagram for data acquisition, logging, and transmission to the VTTI DAS.	8
Figure 8. Chart. Overall A-weighted SPL for MY2018 production.....	10
Figure 9. Chart. Overall A-weighted SPL for FP.	10
Figure 10. Chart. Overall A-weighted SPL for RT.....	11
Figure 11. Chart. Overall A-weighted SPL for U.	11
Figure 12. Chart. Overall A-weighted SPL for MY19.	12
Figure 13. Charts. Overall A-weighted SPL profile for the MY2018 sound at 10 and 20 km/h.....	13
Figure 14. Charts. Overall A-weighted SPL profile for the FP sound at 10 and 20 km/h..	13
Figure 15. Charts. Overall A-weighted SPL profile for the RT sound at 10 and 20 km/h. .	14
Figure 16. Charts. Overall A-weighted SPL profile for the U sound at 10 and 20 km/h.	14
Figure 17. Charts. Overall A-weighted SPL profile for the MY19 sound at 10 and 20 km/h.....	14
Figure 18. Charts. Overall A-weighted SPL profile with no sound at 10 and 20 km/h.....	15
Figure 19. Chart. Average number of days per week participants cross a street, by environment.....	18
Figure 20. Diagram. Scale test environment.	19
Figure 21. Diagram. Scaled diagram of participant seating area.....	20
Figure 22. Photo. Test vehicle approaching participants from their right (heading NW)...	20
Figure 23. Photo. Test vehicle approaching participant seating area from the left (heading SE).	21
Figure 24. Photos. Positioning of participant chairs and microphones.	21
Figure 25. Photos. Suitcase NextGen DAS.....	22
Figure 26. Photos. Novatel antenna (left) and AvaLAN transmitter (right).	22
Figure 27. Screen capture. Captured video views.....	23

Figure 28. Photo. Handheld button.....	23
Figure 29. Chart. Background noise spectrum.....	24
Figure 30. Screenshot. Equalizer used to shape the white noise.....	24
Figure 31. Diagram (left) and photo (right). Background noise generation signal path (left) and actual arrangement (right).....	25
Figure 32. Charts. Average background noise spectrum for 55 dBA (top) and 60 dBA (bottom).....	26
Figure 33. Photos. Mounted weather station (left) and digital display (right).....	27
Figure 34. Chart. Heatmap of wind and temperature measurements across all listener sessions.....	27
Figure 35. Diagram. Straight line distance calculations.....	28
Figure 36. Chart. Average detection distances for steady speed approaches by 55-dB noise level.....	30
Figure 37. Chart. Average detection distances for steady speed approaches by 55-dB noise level (original phase).....	31
Figure 38. Chart. Average detection distances by sound condition for 10-km/h approach at 55-dBA noise level.....	32
Figure 39. Chart. Distribution of cases for 10 km/h at 55 dBA.....	33
Figure 40. Heat maps. Detection heat maps for 10 km/h at 55 dBA.....	34
Figure 41. Chart. Average detection distance by sound condition for 20-km/h approach at 55 dBA.....	35
Figure 42. Chart. Distribution of cases for 20 km/h at 55 dBA.....	36
Figure 43. Heat maps. Detection heat maps for 20 km/h at 55 dBA.....	36
Figure 44. Graph. Average detection distances by sound condition for both steady-speed approaches at 55 dBA vs. 60 dBA.....	37
Figure 45. Chart. Average detection distance by sound condition for 10-km/h approach at 60 dBA.....	38
Figure 46. Chart. Distribution of cases at 10 km/h and 60 dBA.....	39
Figure 47. Heat maps. Detection heat maps for 10 km/h at 60 dBA.....	39
Figure 48. Chart. Average detection distance by sound condition for 20-km/h approach at 60 dBA.....	40
Figure 49. Chart. Distribution of cases at 20 km/h and 60 dBA.....	41
Figure 50. Heat maps. Detection heat maps for 20 km/h at 60 dBA.....	41
Figure 51. Chart. Safe to cross categorical responses at 55 dBA.....	43
Figure 52. Chart. Safe to cross categorical responses at 55 dBA for original study.....	43

Figure 53. Chart. Percentage of correct “safe to cross” responses by approach direction at 55 dBA.	44
Figure 54. Chart. Safe to cross categorical responses at 60 dBA.	44
Figure 55. Diagram. Seven-point scale for participant questionnaire responses.....	45
Figure 56. Chart. Post-drive Questionnaire Q1 – appropriateness.....	45
Figure 57. Chart. Post-drive Questionnaire Q2 – easier to detect.....	46
Figure 58. Chart. Post-drive Questionnaire Q3 – effectively communicates approaching EV.....	47
Figure 59. Chart. Post-drive Questionnaire Q4 – increases pedestrian safety.....	48
Figure 60. Chart. Post-drive Questionnaire Q5 – annoying.	49

LIST OF TABLES

Table 1. NHTSA Minimum 1/3 Octave Band Levels.....	5
Table 2. Average Daily Ambient Background Noise Levels	9
Table 3. Test Scenarios	15
Table 4. Participant Schedule	16
Table 5. Participant Demographics.....	18

LIST OF ABBREVIATIONS AND SYMBOLS

ANSI	American National Standards Institute
DAS	data acquisition system
dB	decibel
dBA	decibel, A-weighted
DGPS	Differential Global Positioning System
DIN	Deutsches Institut Fur Normung E.V. (German National Standard)
EV	electric vehicle
FMVSS	Federal Motor Vehicle Safety Standards
GM	General Motors
Hz	hertz
ICE	internal combustion engine
IEC	International Electrotechnical Commission
ISO	International Organization for Standardization
JIS	Japanese Industrial Standard
kph	kilometers per hour
m	meters
NHTSA	National Highway Traffic Safety Administration
NSTSCE	National Surface Transportation Safety Center for Excellence
SPL	sound pressure level
UNECE	United Nations Economic Commission of Europe
VTI	Virginia Tech Transportation Institute

CHAPTER 1. INTRODUCTION

The National Highway Traffic Safety Administration's (NHTSA's) recently released Traffic Safety Facts⁽¹⁾ revealed that pedestrian fatalities in 2016 increased by 9% (+492) over the previous year, reaching their highest mark since 1990. Although this increase can likely be attributed to a variety of causes, including distraction by pedestrians and drivers alike, steadily increasing sales of "quiet vehicles" are altering how vehicles are perceived within traditional roadway environments due to their quiet operating noise relative to their internal combustion engine (ICE) counterparts. Recent estimates suggest that over two million plug-in electric vehicles (EVs) had been sold globally as of December 2016.⁽²⁾ This trend shows no signs of slowing down, with automakers, such as General Motors, suggesting full shifts towards electric-only vehicles within the next decade.⁽³⁾

In response to concerns raised regarding decreased detectability, many auto manufacturers are now producing non-ICE vehicles with an additive noise component aimed at signaling vehicle presence in the same way approaching ICE vehicles signal their presence through engine noise. The Virginia Tech Transportation Institute (VTTI) conducted an evaluation of quiet car detectability as part of a GM-funded project in 2015–2016.^(4, 5, 6) This initial evaluation conducted vehicle noise testing based on methods outlined in the United Nations Economic Commission of Europe (UNECE)⁽⁷⁾ and the developing NHTSA regulations available at the time. The primary focus thereafter involved testing a pedestrian detectability component, where vision-impaired participants were positioned on the side of the road as they evaluated four vehicle types (and related sound conditions) approaching at specific speeds. These vehicles included a 2011 Chevrolet Volt (EV, no additive sound), a 2014 Cadillac ELR (EV, production additive sound), a 2013 Toyota Prius (hybrid vehicle, production additive sound under EV mode), and a 2013 Cadillac SRX (ICE benchmark). Though each vehicle exceeded the UNECE minimum vehicle noise level, this initial evaluation revealed that none of the vehicles, including the ICE benchmark, were immune to missed or late detections. Furthermore, the ICE benchmark significantly outperformed the other three vehicles under the 10-km/h steady approach, but these differences largely disappeared at 20 km/h due to increased tire and road noise. Trends of improved detectability offered by the additive noise signals were observed but did not demonstrate a significant advantage over the EV with no additional noise component.

Since that original project, NHTSA has released their final version of Federal Motor Vehicle Safety Standard (FMVSS) 141, outlining "Minimum Sound Requirements for Hybrid and Electric Vehicles."⁽⁸⁾ These regulations open the door for a new generation of additive sounds, and this project aimed to demonstrate differences in detectability by replicating the previous study but with newer FMVSS 141-compliant sounds. As such, this project was guided by the primary objective of identifying the detectability of "next-generation" quiet vehicle additive sounds, comparing performance to the previously collected vehicle sample.

Funding for this project was provided by both the National Surface Transportation Safety Center for Excellence (NSTSCE) and General Motors (GM). Certain details regarding the GM-provided sound profiles are absent from this report due to their proprietary nature. Importantly, these details do not limit the presentation and discussion of results, nor limit the overall findings, particularly the demonstrated benefit offered by these additive sound conditions.

CHAPTER 2. METHODS

OVERVIEW

This section provides an overview of all tasks performed, up to and including formal data collection during the listener evaluations, where participants were asked to detect an approaching vehicle with different sounds from either direction.

TEST SITE

Testing under this project took place on the same section of roadway used during the previous study. As highlighted by the shaded area in Figure 1, all testing was contained within the area at the lower end of the Virginia Smart Road, beyond the bridge. This closed test bed adjacent to VTTI in Blacksburg, Virginia, was originally selected based on its ability to provide:

- A safe (controlled) environment conducive to testing with “pedestrians” seated on or near the roadway
- Low ambient noise levels
- A level roadway
- A road surface representative of typical roadways
- A site length appropriate for dynamic maneuvers



Figure 1. Satellite map. Virginia Smart Road test site (Source: Google Maps).

As Smart Road access is controlled, testing could be conducted with the guarantee that no other vehicles would enter the defined testing area. The noise levels at the selected site were the lowest of any measured site during the site selection process ahead of the original project and were not directly impacted by any surrounding primary roadways. The roadway was relatively level (an approximate 1% grade) with sufficient distance to support the maneuvers performed during the listener testing. Finally, the condition of the roadway surface was representative of typical

asphalt-paved roadways throughout Virginia (Figure 2), but was not representative of new pavement. This section of roadway section was swept ahead of every measurement and test session to minimize the influence of rocks or other debris.



Figure 2. Photo. Smart Road asphalt surface at test site.

VEHICLE NOISE TESTING

The research team conducted benchmark vehicle noise testing of all sound conditions, measuring the overall sound pressure level (SPL) and 1/3 octave band levels of the sounds while stationary and during steady approach speeds of 10 km/h and 20 km/h. Testing followed the procedures outlined in FMVSS 141,⁽⁸⁾ which provides guidelines on microphone spacing, vehicle speeds, and criteria for determining compliance. Results included within this report are specific to testing conducted at the selected test location at the bottom of the Smart Road. The test area and microphone locations are illustrated in Figure 3 for stationary testing and testing at steady approach speeds of 10 km/h and 20 km/h, with microphone heights set to 1.2 m.

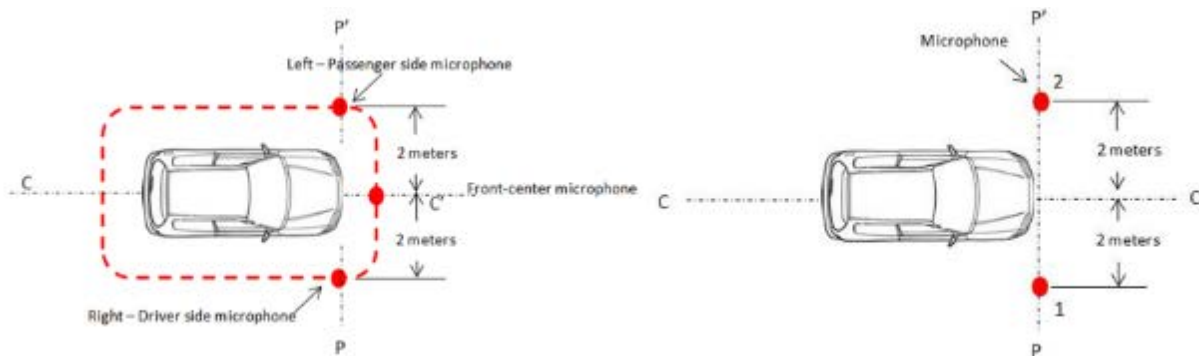

Figure 3. Diagrams. Stationary (left) and dynamic (right) testing diagrams from FMVSS 141 testing procedures.

Testing was done to ensure that the sounds met the minimum NHTSA level requirements for overall SPLs and 1/3 octave bands, along with additional GM-internal requirements. Table 1 provides the NHTSA minimum levels for 1/3 octave bands.⁽⁸⁾

Table 1. NHTSA Minimum 1/3 Octave Band Levels

Range	Band Centers	< 10 km/h
Low	315	39
	400	39
	500	40
	630	40
	800	41
High	1000	41
	1250	42
	1600	39
	2000	39
	2500	37
	3150	34
	4000	32
	5000	31

Additional requirements were as follows:

- Additive sound octave bands must exceed the NHTSA minima in at least one band from both high and low ranges. The two bands must be non-adjacent (i.e., low band 800 Hz > 41 dBA and high band 1000 Hz > 41 dBA is not allowed).
- Second, the peak of the overall SPL at the microphone position with the lowest overall level (front, driver, or passenger) must achieve at least 52 dBA. (This was a GM requirement.)
- Third, the sum of the two bands that exceed the NHTSA minima should be ≥ 48.3 dBA (GM requirement; 4.3 dBA above FMVSS minima of 44 dBA).

Test Vehicle and Additive Sound Conditions

GM provided a 2018 Chevrolet Bolt for the duration of the project. Since testing involved evaluation of non-production additive sounds, a pair of Bose SoundLink speakers, cables, and instructions on how to mount these to the vehicle were also provided. VTTI developed hard mounts for speaker installation (Figure 4), running the cables into the cabin where speaker output could be controlled via a GM-supplied “Sound Mixer” program installed on an experimenter laptop. This program allowed inputs to control volume and speed-based sound-shifting characteristics as determined through static and drive-by testing. Although the production implementation is likely to be different, it should be noted that the focus of this research effort is on examining the detectability of candidate sounds that meet or exceed the current FMVSS 111 guidelines. The external mounting, along with the Sound Mixer program, allowed the sound profiles to be fine-tuned in a manner that a currently implemented additive sound speaker could likely not achieve. Finally, VTTI installed a fuse cut-off switch in the vehicle cabin in order to disable the production Pedestrian Friendly Alert Function (PFAF) sound. This PFAF is production additive sound that is emitted while the vehicle is in motion. This was disabled during testing so as not to influence or interfere with the other sound profiles.



Figure 4. Photos. 2018 Chevrolet Bolt and front speaker mount.

GM provided four sound files for testing, referenced as follows: (1) MY19, (2) FP, (3) U, and (4) RT. The MY19 sound file represented the anticipated production sound for model year 2019 GM vehicles, while the other three were prototype sounds under development. Additional details pertaining to the sound profiles are offered in forthcoming sections.

VTTI conducted multiple rounds of stationary and drive-by testing, providing output to GM for confirmation that sound level outputs met expectations. The vehicle was fully charged prior to each testing session, with heating, ventilation, and air conditioning turned off during all measurements and subsequent participant testing. Ultimately, during a visit by GM personnel, it was determined that the single front speaker did not provide enough spatial output to meet the SPL criteria to the sides, while over-achieving directly forward. VTTI modified the front speaker mount to accommodate two speakers, angled outward, as shown in Figure 5. A final round of testing was conducted before receiving the go-ahead from GM to proceed with listener testing.



Figure 5. Photos. Modified front speaker mount.

Data Acquisition and Analysis System

Three types of acoustic measurements were recorded during the course of this project: acoustic pressure, overall A-weighted SPL, and 1/3 octave band SPLs (also A-weighted). The major components of the noise measurement data acquisition system (DAS) were as follows:

- Four G.R.A.S. 46AQ ½" TEDS Microphones
- One National Instruments cDAQ USB Data Acquisition Rack
- One National Instruments NI 9234 analog-to-digital converter module
- One Dell Inspiron Desktop PC (8 GB RAM 1 TB HD) running MATLAB
- National Instruments Labview
- National Instruments Labview Acoustics and Vibrations Measurement Suite

This hardware and software combination provides a Class 1 system that meets or exceeds the following standards: International Electrotechnical Commission (IEC) 61260: 1995, Class 1, IEC 61672: 2002, Class 1, JIS C 1509-1: 2005, JIS C 1514: 2002, ANSI S1: 11 - 2004, Class 1, ANSI S1.4: 1983, ANSI S1.42: 1986, ISO 8041: 2005(E), ISO 532: 1975, DIN 45631: 1991, DIN 45631/A: 2008. This acquisition package was configured as shown in Figure 6.

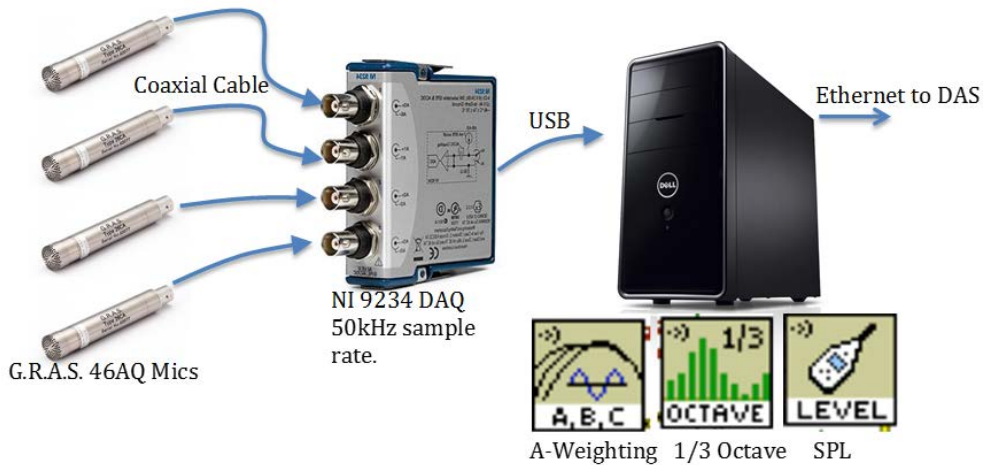

Figure 6. Photo diagram. Hardware and software used for acoustic measurements.

The software logic implemented to acquire, store, and transmit data is illustrated in Figure 7. Data provided by the microphones were sampled at 50 kHz and saved so that all raw pressure measurements were logged for all tests. Simultaneously recorded with the raw pressure measurements, data passed through an A-weighting filter before being split and passed to a sound level meter in order to calculate overall SPL (0.125 s exponential averaging or “fast” setting) and 1/3 octave band sound pressure levels. Overall SPL and 1/3 octave band calculations were logged on the PC and transmitted over ethernet to the VTTI DAS at a rate of 10 Hz.

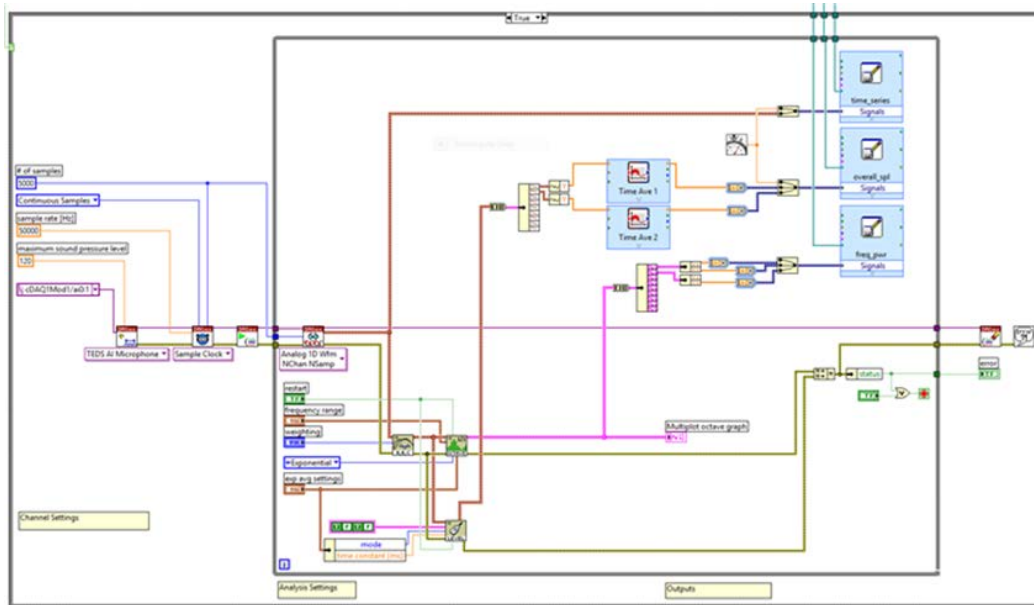

Figure 7. Diagram. Labview block diagram for data acquisition, logging, and transmission to the VTTI DAS.

Each microphone was calibrated before and during all testing using a G.R.A.S. 42AA pistonphone calibrator. The 42AA (114 dB at 250 Hz) complies with all requirements of IEC Standard 942 (1988) Sound Calibrators Class 1, and was corrected with a G.R.A.S. ZC0002K barometer.

The data acquisition and analysis system described above was used for both the vehicle-noise tests and for the listener testing.

Background Noise

Ambient background measurements were recorded periodically throughout all testing. Table 2 provides daily averages of the ambient levels. The very low level on December 13, 2018, is due to the roughly 10 inches of snowfall at the site (only date with snow on the ground). All of the overall levels are at least 10 dB below the 52-dBA overall target level for the additive sounds so no correction due to elevated background noise was necessary.

Table 2. Average Daily Ambient Background Noise Levels

Test Date	Average daily A-Weighted SPL	Recording Period
October 19, 2018	38.5 dBA	Final Measurements
November 11, 2018	39.6 dBA	Listener Session #1
November 18, 2018	40.1 dBA	Listener Session #2
November 19, 2018	41.3 dBA	Listener Session #3
November 29, 2018	40.4 dBA	Listener Session #4
December 13, 2018	35.4 dBA (heavy snowfall)	Final Measurements (round 2)

Noise Measurement Results

Using the geometry in Figure 3, 20-second-long measurements were taken and recorded by the DAS while the vehicle remained stationary. Adjustments were made across multiple rounds of testing to ensure that the sounds met the targeted criteria, with final measurements represented herein. Figure 8 through 12 provide results for the overall A-weighted SPL. Due to the proprietary nature of the sounds examined, figures illustrating measurements across the 1/3 octave bands have been omitted. The overall SPL plots provide the time history of the overall A-weighted SPL at each of the microphones. The peak level is provided for each microphone position at the bottom of the overall SPL plots. For comparison, the production sound on the test vehicle (MY2018 PFAF) is included in the following charts.

The production MY2018 sound results provided in Figure 8 show that this sound had the lowest overall A-weighted SPL of all of the sounds in front of the vehicle. This sound was significantly higher on the passenger side than the other sounds tested, likely due to the location of the factory-installed speaker. This sound was the only sound that did not pass the implemented 2-band criterion. Additionally, the front position (lowest overall SPL) did not meet the 52-dB peak criterion. As a reminder, this sound was not included in the subsequent listener testing component and is only included herein for reference.



Figure 8. Chart. Overall A-weighted SPL for MY2018 production.

The passenger-side microphone had the lowest overall level SPL for the FP sound condition (Figure 9). The 1/3 octave band results (not included) illustrated that several bands in both the upper and lower ranges exceeded the NHTSA minima, and that the 2-band sum came within 0.1 dBA of the 48.3 dB target. The passenger side overall peak level was ≈ 1 dBA below the 52-dBA requirement suggested by GM.

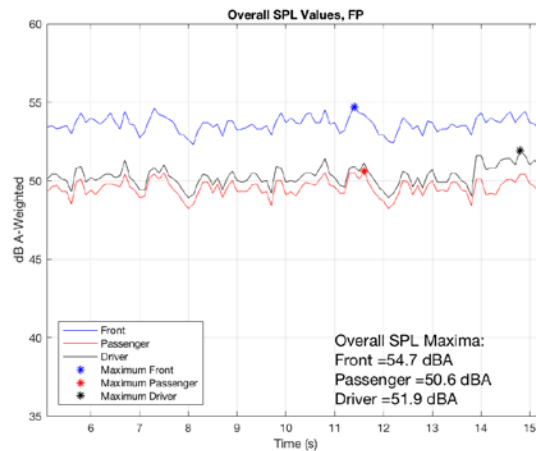

Figure 9. Chart. Overall A-weighted SPL for FP.

The RT sound had a tempo that was almost impulsive, as evidenced by the time series plot of the overall SPL (Figure 10). The 1/3 octave band results (not included) illustrated that the 1-band in both the upper and lower ranges exceeded the NHTSA minimum, and that the 2-band sum also fell close to the 48.3 dB-target. The passenger side microphone captured the lowest overall level, with an overall peak ≈ 1 dBA below the 52-dBA GM-suggested requirement.

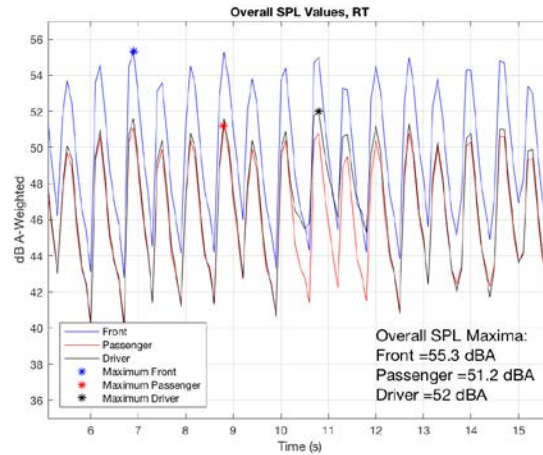

Figure 10. Chart. Overall A-weighted SPL for RT.

The U sound elicited a spectrum containing much lower frequency energy compared to the other sounds (Figure 11). The 1/3 octave band results (not included) illustrated that several bands in both the upper and lower ranges exceeded the NHTSA minimum, and that the 2-band sum met the 48.3-dB target. Again, the passenger side microphone captured the lowest overall level, with an overall peak ≈ 1 dBA below the 52-dBA requirement suggested by GM.

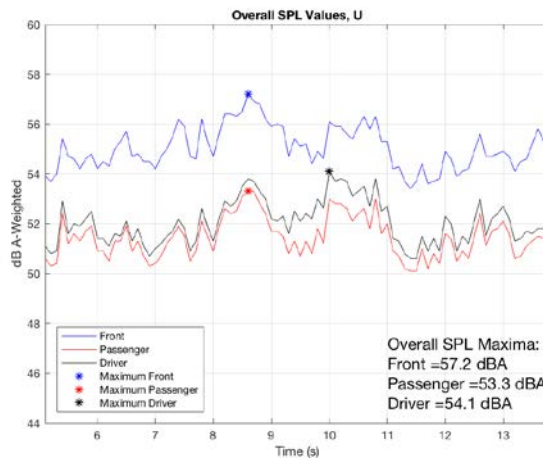

Figure 11. Chart. Overall A-weighted SPL for U.

The MY19 sound had the highest overall SPL in front of the vehicle (Figure 12). The driver-side microphone had the lowest overall level. The 1/3 octave band results (not included) illustrated that several bands in the lower range and one band in the upper range exceeded the NHTSA minima, and that the 2-band sum met the 48.3-dB target. The passenger side overall peak level exceeded the 52-dBA requirement by ≈ 3 dBA. This level was very high due to the 2-band requirement—i.e., for the single upper-range octave band to exceed the NHTSA requirement, the

overall level had to be increased. This created a very loud sound at the front of the vehicle (see additional text below).

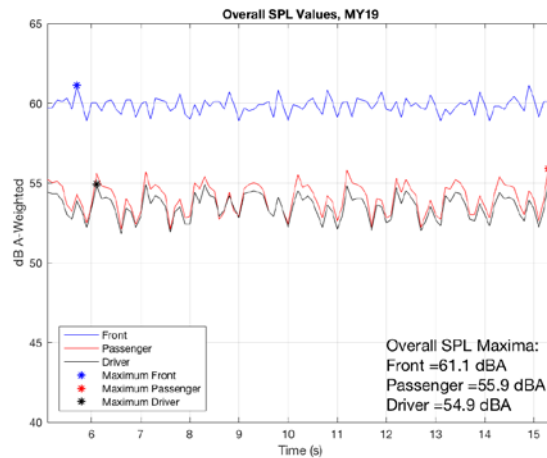

Figure 12. Chart. Overall A-weighted SPL for MY19.

In all of the cases above (excluding the factory MY2018 sound because it did not use the front-mounted speaker arrangement), the overall A-weighted SPL in front of the vehicle was 3–6 dBA above the lowest overall SPL for that sound. The MY19 sound was the extreme across sound configurations, with a front SPL approximately 6 dB above the level on the sides of the vehicle. These differences can be attributed to the speaker arrangement used to transmit the test sounds. First, the speakers were not omnidirectional. Using two speakers increased coverage to the sides of the vehicle, but also increased the overall level in front of the vehicle. Secondly, the spacing of the two speakers caused phase-related cancellation of frequencies in the 1,250 Hz range. In order to fully understand directionality issues posed by the finalized speaker arrangement, measurements in an anechoic chamber on a turntable would be required.

Dynamic Measurement Results for 10 and 20 km/h

Similar noise-based measurements were collected at steady approach speeds of 10 km/h and 20 km/h using the same microphone configuration (Figure 3), sans the forward microphone. As these measurements were conducted on the same dates as the stationary tests, the same background noise measurements shown earlier (Table 2) still applied. Figure 13–18 show the drive-by results for each of the examined sound configurations. Due to the centralized location of the speaker, the right and left measurements are consistent with each other, so the right-only charts have been omitted from this section for brevity. As a reminder, the sound profiles were configured to adjust output as speed varied (sound-shifting), so SPL measurements are noticeably higher as speed increases, beyond the increased road and tire noise.

The results illustrate that the additive sounds in this round of testing reached a much higher peak level than the results for EVs in the previous study. In that study, the vehicle with the highest overall A-weighted SPL was the ICE vehicle (Cadillac SRX). The SRX had a maximum overall level of 60 dB at 10 km/h and 64 dB at 20 km/h. The EVs with a production additive sound in that study reached between 52 dBA (Prius) and 56 dBA (ELR) at 10 km/h, and 62 dBA (Prius)

and 64 dBA (ELR) at 20 km/h. For the test sounds in this study, almost all sounds crossed the 60-dBA line at 10 km/h (FP was 59.5 dB), and all crossed the 65-dBA line at 20 km/h.

These results again indicate that the SPL in front of the vehicle was quite high in order to meet the minimum requirements at the sides of the vehicle. The likely culprit here is again the directionality of the speaker arrangement.

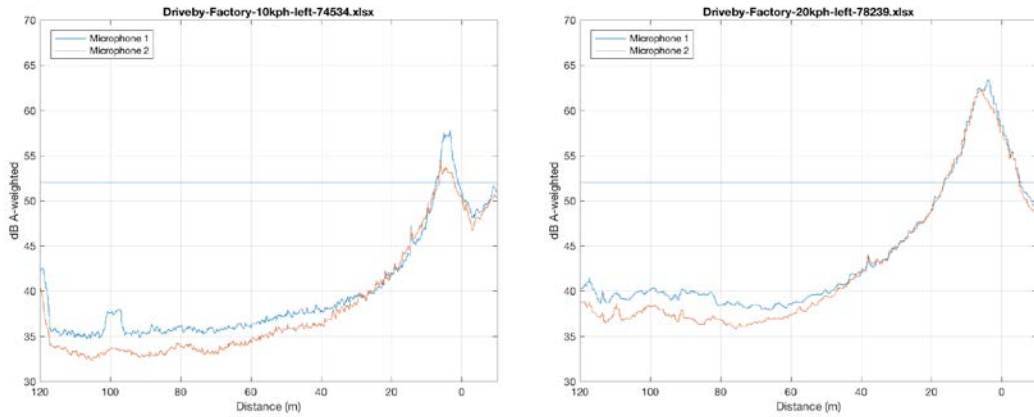

Figure 13. Charts. Overall A-weighted SPL profile for the MY2018 sound at 10 and 20 km/h.

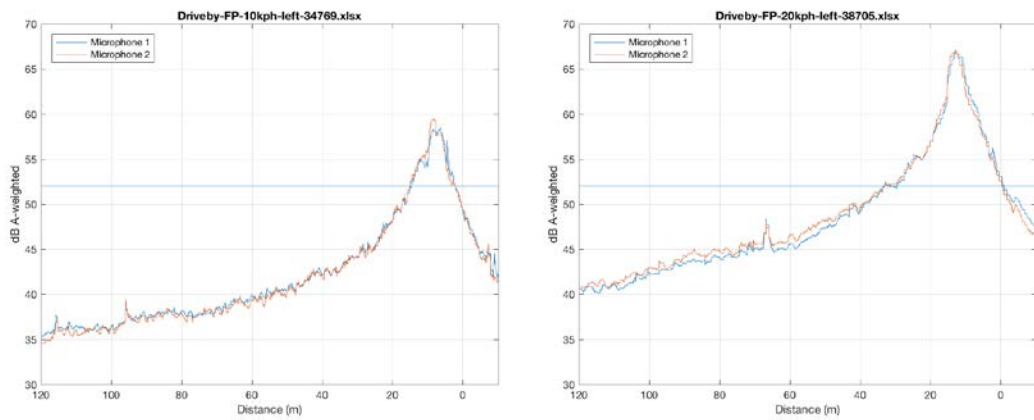

Figure 14. Charts. Overall A-weighted SPL profile for the FP sound at 10 and 20 km/h.

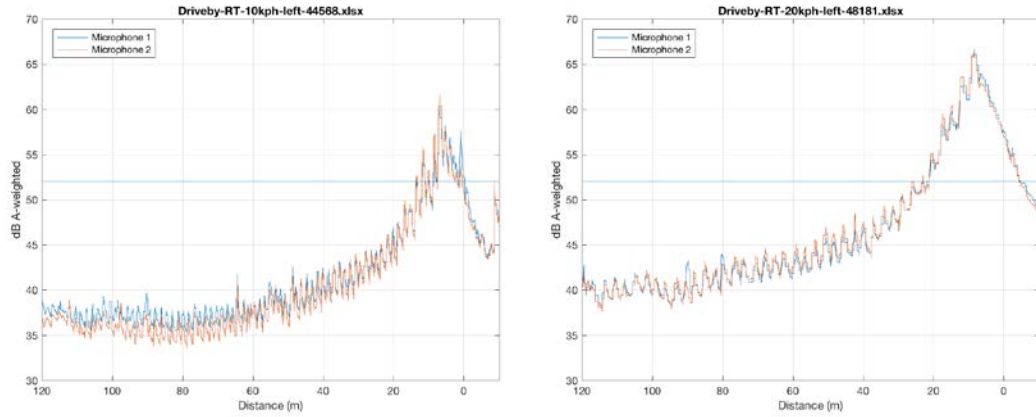

Figure 15. Charts. Overall A-weighted SPL profile for the RT sound at 10 and 20 km/h.

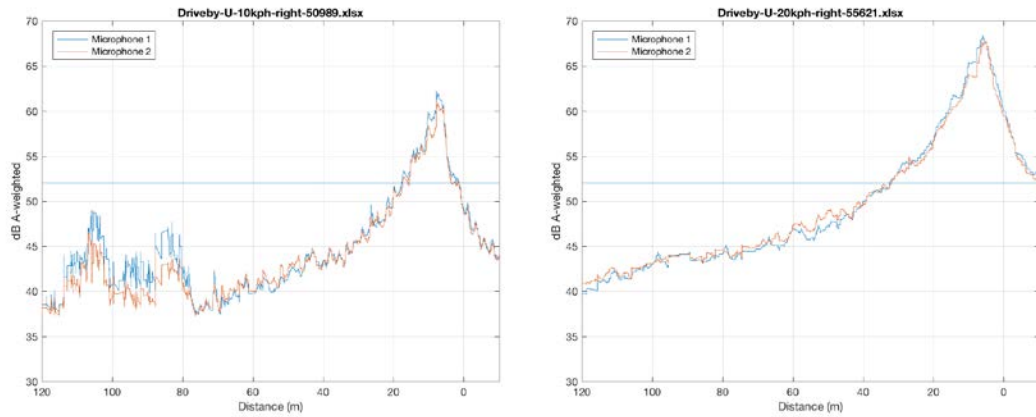

Figure 16. Charts. Overall A-weighted SPL profile for the U sound at 10 and 20 km/h.

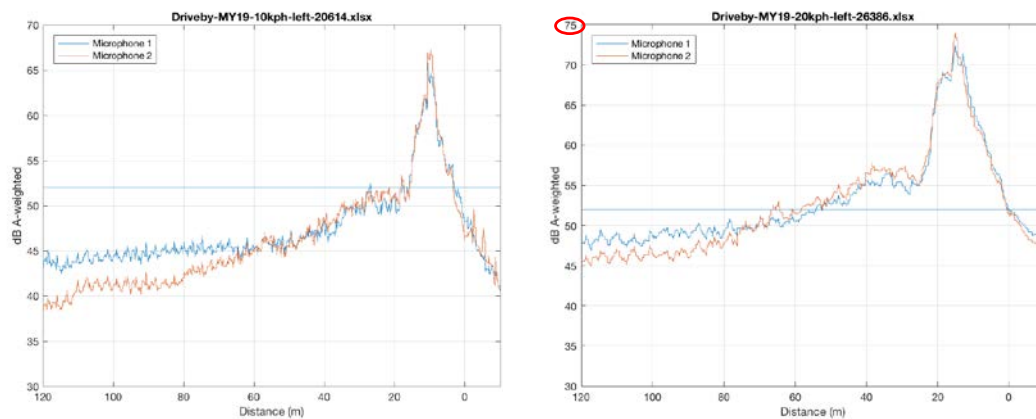

Figure 17. Charts. Overall A-weighted SPL profile for the MY19 sound at 10 and 20 km/h.

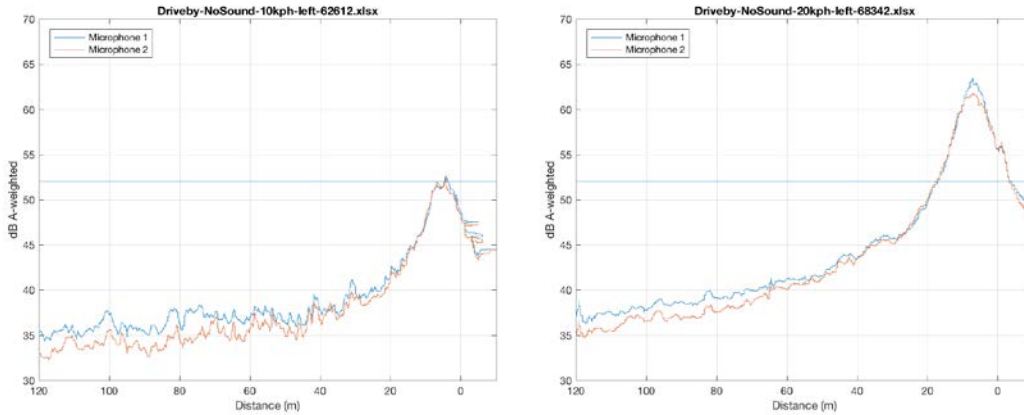

Figure 18. Charts. Overall A-weighted SPL profile with no sound at 10 and 20 km/h.

LISTENER TESTING

VTTI maintained the same approach and procedures implemented during the original study. The primary change was no longer requiring participants who were vision-impaired. Individuals were recruited to participate in a daylong session, evaluating the detectability of an approaching vehicle presenting different additive sound conditions within a controlled environment.

Approaching scenarios incorporated two levels of steady-state speeds, along with one where the vehicle came to a stop directly in front of the participants. As such, participants were asked to not only identify when they detected the approaching vehicle, but also the point at which it was safe to cross. The prescribed artificial background noise was examined at the proposed dBA level, as well as at a second, higher level.

Study Design

The final study design accommodated three subject factors, as illustrated in Table 3. These factors included EV sound conditions (5 levels), approach speed (3 levels), and background noise level (2 levels). This $5 \times 3 \times 2$ design provided 30 unique configurations, each repeated twice in both the left and right directions, for a combined four repetitions per trial. With the addition of six practice trials, each participant experienced 126 total scenarios per data collection session.

Table 3. Test Scenarios

Levels	EV Sound Conditions	Approach Speed	Background Noise	Unique Scenarios
1	MY19	Steady (10 km/h)	Moderate (55 dBA)	$5 \times 3 \times 2 = 30$
2	FP	Steady (20 km/h)	Alternative Level (60 dBA)	
3	U	Slowing to a Stop (20 km/h–0 km/h)	---	
4	RT	---	---	
5	No Sound (baseline)	---	---	

Study Schedule and Procedure

Following a phone screening (Appendix A), eligible participants were scheduled to attend a single daylong session at VTTI. Due to the resources required for each data collection session, the protocol accommodated four participants per session. Table 4 provides a typical agenda for the required daylong session. To minimize fatigue due to session lengths required to run all 126 targeted scenarios, the evaluations were divided into two on-road portions, separated by a lunch break (lunch provided on-site). Furthermore, breaks were offered approximately every hour, in addition to whenever requested by any of the four participants per session.

Table 4. Participant Schedule

Time	Task	Description	Allotted Time
9:00–10:00	Arrive; Paperwork; Hearing test	Participants arrive; complete Informed Consent Form and misc. paperwork; complete required hearing evaluations	1 hour
10:00–12:00	SR Session #1	Orientation to Protocol; 6 Practice Trials; Exposure to 60 scenarios (1/2 of total) on Smart Road	2 hours
12:00	Lunch		1 hour
1:00–3:00	SR Session #2	Exposure to remaining 60 scenarios (1/2 of total) on Smart Road	2 hours
3:00–3:30	Post-Drive Questionnaire	Capture subjective feedback regarding sound conditions	0.5 hour
3:30–4:00	Debrief	Debrief and payment	0.5 hour
Total	~7 hours		

Meet and Greet

Upon arrival, participants were escorted to a conference room where VTTI experimenters guided each participant (four per session) through the necessary paperwork and pre-testing. Participants reviewed and signed the Informed Consent Form (Appendix B). Afterwards, experimenters administered a pre-drive questionnaire (Appendix C) assessing how often they crossed streets, both overall and separately by rural and urban environments.

A hearing test was administered (Appendix D) in order to capture each participant's hearing state across frequency bands, by ear. A Smart Tone testing device, manufactured by Smart Diagnostic Devices, presented a series of three tones across different dBA levels. Participants were asked to press a handheld button each time they heard a tone, with assessments completed for both right and left ears. Results from the hearing tests were not considered for basis of exclusion from participating, although it should be noted that the initial phone screening required normal or corrected-to-normal hearing in order to meet eligibility. Results are provided in Appendix E, and, based on comparisons of mean detection distances relative to hearing test results, hearing state is not believed to have had any impact on the findings.

Once all participants completed these pre-study tasks, a brief overview of the day's schedule and activities was provided to the group (Appendix F). Following any questions, the participants were then transported to the Smart Road test site.

Test Site and Protocol Familiarization

A second overview was provided to participants prior to exiting the transport vehicle (Appendix G) once they arrived at the test site. Participants were instructed that, while seated, they would mimic pedestrians waiting to “cross” an intersection while vehicles approached. Participants were instructed to wear sleep shades to block their view of the approaching vehicle. Due to the time of year when testing took place, electric blankets were also provided. Participants were permitted to wear hats, so long as their ears remained uncovered.

Participants were asked to both identify when they detected an approaching vehicle and indicate when it was “safe to cross.” The safe-to-cross component varied based on maneuver. For cases where vehicles approached and passed at a constant speed, participants were asked to indicate the safe-to-cross point at the moment they recognized the vehicle had passed their seated location and was no longer a threat. Alternatively, for cases where the vehicle stopped directly in front of their location, participants were asked to indicate the safe-to-cross point at the moment they recognized the vehicle had stopped, under the assumption that the driver of the vehicle was yielding and allowing them to cross.

Test Evaluations

Once participants understood the protocol and their responsibilities, they completed six practice trials before continuing with the defined test scenarios. Researchers monitored each participant’s detection and safe-to-cross identification points during these practice trials, and any indications of misunderstanding were addressed prior to conducting the actual test scenarios.

Formal testing commenced once researchers and participants were comfortable with the protocol. Presentation order was randomized among the 60 scenarios for each approach direction (30 configurations at two trials each) in order to combat order effects. Ordered scenarios by approach direction were then zip-merged together, one direction at a time, to eliminate any dead time and improve efficiency in the formal testing (“left” trial always followed by a “right” trial).

Debrief and Payment

Upon completion of the morning and afternoon sessions, participants returned to VTTI headquarters, where they completed a post-drive questionnaire that allowed them to provide feedback on the sound configurations they experienced (Appendix H). Upon completing the post-drive questionnaire, participants were thanked for their time and paid \$250 for participating.

Participants

Sixteen individuals from the New River Valley and surrounding localities (e.g., Salem, Roanoke, etc.) were recruited for participation in this study. Consistent with the previous study, specific age groups were not targeted. Table 5 provides further detail pertaining to participant sample, both by gender and age. Vision-impairment was not required for eligibility, as it was not expected to impact vehicle detectability measurements.⁽⁹⁾

Table 5. Participant Demographics

Gender	N=	Participant Age			
		Mean	Std Dev	Min	Max
Female	7	47.6	16.9	24	79
Male	9	42.9	21.4	21	80
Total	16	44.9	19.1	21	80

Independent Street Crossing

Participants indicated their typical experience crossing the street within the pre-drive questionnaire. Participants were asked to indicate how frequently they crossed the street on a weekly basis, both overall and separated out by urban and rural environments (three separate responses). As illustrated in Figure 19, exposure to weekly street crossing was well distributed across the participant sample, from never to daily. This trend differed by environment, however, with a higher reported frequency for street crossing within urban environments relative to rural.

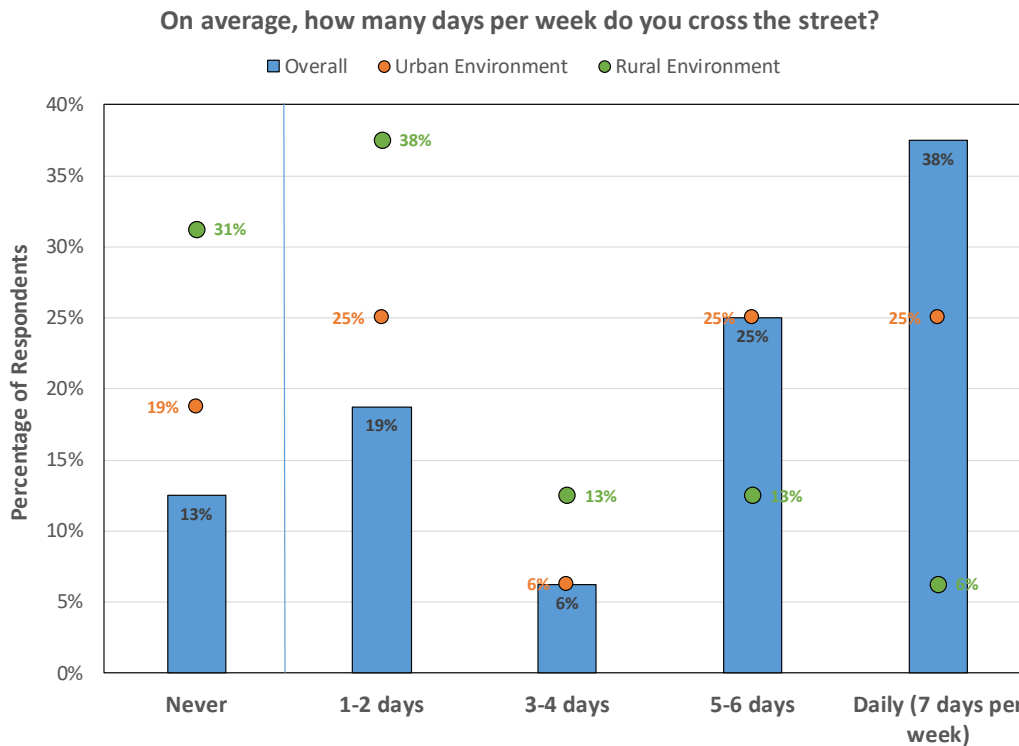

Figure 19. Chart. Average number of days per week participants cross a street, by environment.

Test Site Arrangement

As previously mentioned, the selected test site was located at the lower end of the Smart Road (refer back to Figure 1). Since there was only one research vehicle, trials for this phase of research occurred in both travel directions to help increase data collection efficiency. With this in mind, relative positions for starting points and all cones marking at-speed and slow-down points were mirrored to the right and left of participant seating. Figure 20 provides a scaled representation of the site layout with approach distances. The approaching vehicle had approximately 150 m of space available from the starting point, with an “at-speed” cone positioned 100 m from participant seating. Drivers almost always achieved the prescribed vehicle speed well ahead of this marked point, and were instructed to maintain as close to the prescribed speed as possible once that speed was achieved until they were roughly 17 m past (beyond) the participant seating area. Manual speed maintenance was required as cruise control could not be engaged at these slower speeds. Any trials where speed was ± 2 km/h outside of the target speed were repeated. A cone marking the deceleration point (17 m from center stopping point) provided a reference for when to begin slowing down for the 20-to-0-km/h scenario, maintaining consistency across that maneuver as well.

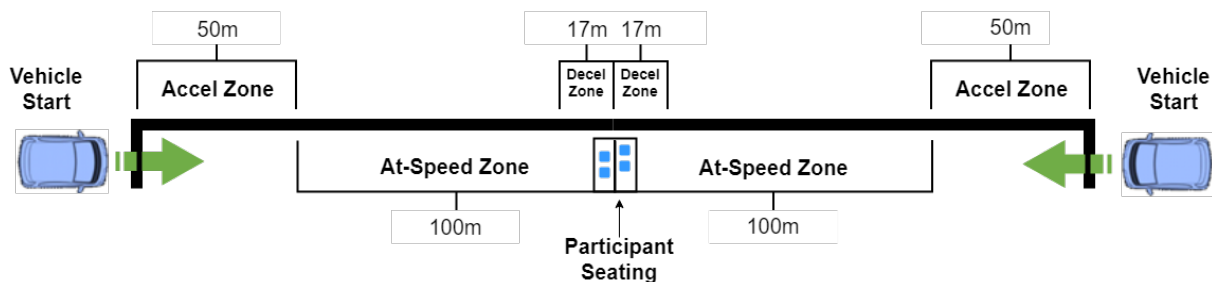

Figure 20. Diagram. Scale test environment.

The participant seating area was at the center of the overall testing location to provide equal working distance for trials performed from either direction. Participants were closely grouped, but in a staggered formation to minimize any sound interference. Five speakers arranged in a parabola surrounded participants situated at the “focus” of this shape to provide the best possible coverage of the white background noise (discussed in an upcoming section). Figure 21 shows the layout of the participant seating area with the speakers shown in black, the subwoofer in maroon, and participant seating locations in blue. Note that the position of items is accurate but that the scale of the actual items might not be.

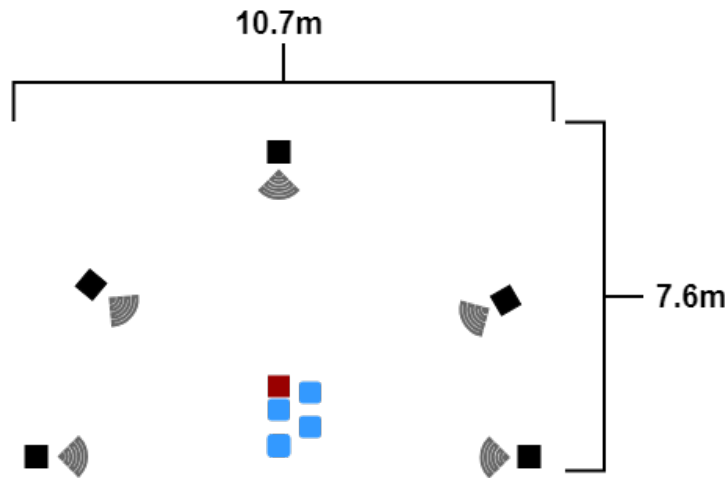

Figure 21. Diagram. Scaled diagram of participant seating area.

Figure 22 and Figure 23 provide perspective of the location and terrain relative to where the participants were positioned. Figure 24 provides close-ups of the participant seating arrangement.



Figure 22. Photo. Test vehicle approaching participants from their right (heading NW).



Figure 23. Photo. Test vehicle approaching participant seating area from the left (heading SE).



Figure 24. Photos. Positioning of participant chairs and microphones.

Instrumentation

Distance and Speed

A modified NextGen DAS was used to support all data collection requirements (Figure 25). Instead of instrumenting the test vehicle, this suitcase-based DAS was configured to communicate with a Differential Global Positioning System (DGPS) unit installed in the

aforementioned test vehicle. This DGPS unit consisted of a Novatel antenna on the vehicle's roof and an AvaLAN transmitter placed on the passenger side dashboard (Figure 26).



Figure 25. Photos. Suitcase NextGen DAS.

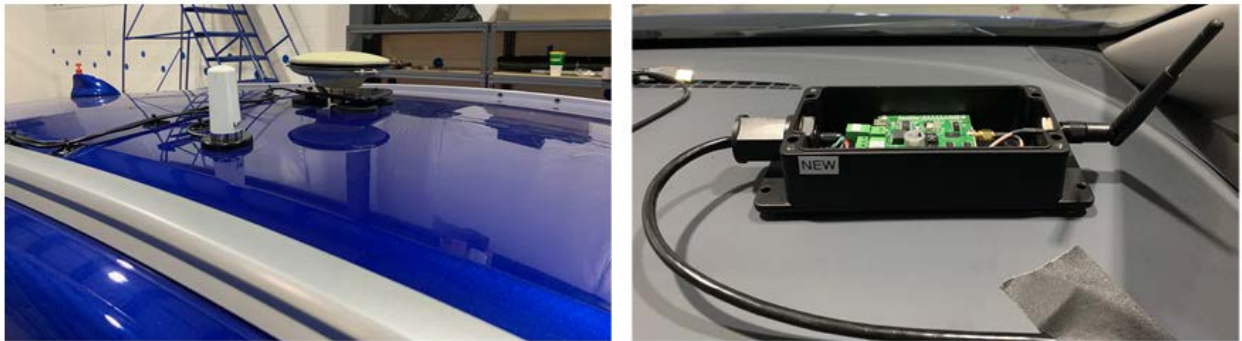

Figure 26. Photos. Novatel antenna (left) and AvaLAN transmitter (right).

This instrumentation approach allowed for continuous recording of base-to-vehicle distance and speed. An experimenter calibrated the transmitter and receiver at the beginning of each test session, ensuring accuracy of the recorded output. Based on the known positions of each participant's seated location with respect to vehicle path and location of antenna relative to the front bumper, accurate distances were calculated post hoc (details provided in a subsequent section).

The NextGen unit, paired with a laptop, allowed the experimenter to both monitor variables of interest in real time and add task codes for each trial to simplify review and analysis. Video (screen capture in Figure 27) was recorded primarily as a method of recording the scenario for verification purposes.



Figure 27. Screen capture. Captured video views.

Each participant was given a handheld button, as illustrated in Figure 28, to record their detection and safe-to-cross points. Participants were instructed to press the button upon detection of an approaching vehicle and continue pressing it until they felt it was safe to cross, at which point they would release the button. These interactions were recorded by the DAS, specific to each participant and trial.



Figure 28. Photo. Handheld button.

Background Noise and Measurement Equipment

The same constant, steady background noise developed and implemented for the earlier project was again included in this round of data collection, generated at two levels: 55 dBA and 60 dBA. The noise spectrum as determined by NHTSA^(10; page 69) is illustrated in Figure 29. The purpose of this noise was to provide a constant background noise representative of an intersection environment. The 55-dBA background noise was selected based on NHTSA's recommendation,

while 60 dBA was included in order to measure the impact on detectability within a noisier intersection environment.

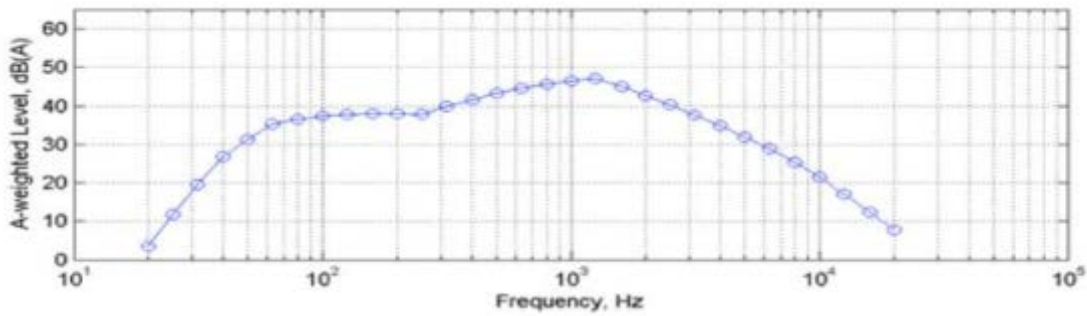

Figure 29. Chart. Background noise spectrum.

The noise was generated in Reaper, a commercially available digital audio workstation. The first step was to use a standard Reaper plugin—white noise to generate white, Gaussian noise. The noise was then filtered using a standard Reaper equalizer plugin, shown in Figure 30. The low frequencies required a significant boost so that when this signal was A-weighted, the spectrum would match the NHTSA profile (Figure 29).

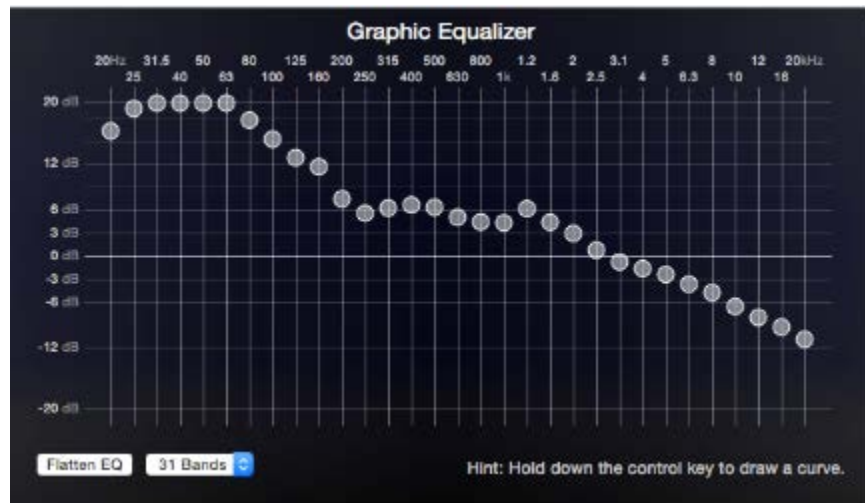

Figure 30. Screenshot. Equalizer used to shape the white noise.

The noise signal was broadcast over five JBL LSR308 loudspeakers and one JBL LSR310S subwoofer. As discussed previously, these speakers were positioned around the sides and to the rear of the participants, creating a sound envelope within which the noise was evenly dispersed. All speaker output was routed through a Focusrite Scarlett 18i20 USB Audio Interface, as shown in Figure 31, which also shows a corresponding image of the on-road arrangement.

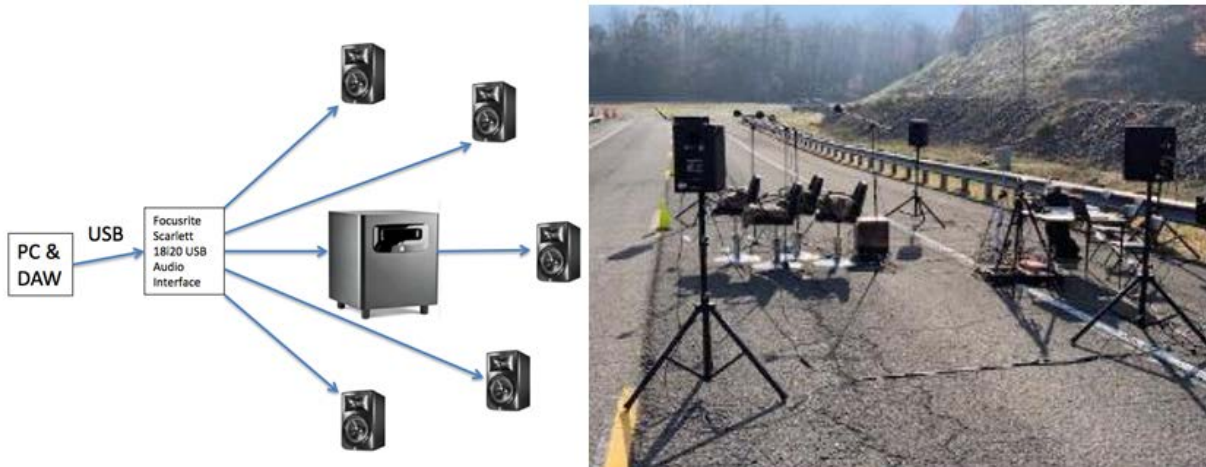

Figure 31. Diagram (left) and photo (right). Background noise generation signal path (left) and actual arrangement (right).

Also pictured above are four microphones that were placed directly above each participant's seated position. Four G.R.A.S. 46AQ ½" TEDS microphones (omnidirectional) were used, with a sensitivity of 50 mV/Pa, a frequency range from 3.15 Hz to 12.5 KHz, and a dynamic range of 17 dBA to 138 dBA. This provided accurate sound pressure levels and 1/3 octave band measurements throughout the experiment. This equipment was all connected through a National Instruments cDAQ USB data acquisition rack and a National Instruments 9234 analog-to-digital converter module to a PC running customized LabView software, which recorded all relevant acoustic measures for each task. Output was also directly routed to the DAS for collection in parallel with the time-stamped DGPS measurements.

Noise verification was conducted throughout listener testing as well. During periods where the vehicle was parked and not running, measurements were recorded and the 1/3 octave band spectra were averaged over all trials to determine the actual signal spectrum received at the microphones. Output is provided for the 55-dBA and 60-dBA levels in Figure 32 below. The area under the curve for the 55-dBA spectrum matches the target spectrum in Figure 29 within 3%. There is a dip in the spectrum at 180 Hz where the LSR308 speakers drop in their response and the subwoofer is unable to counter the loss.

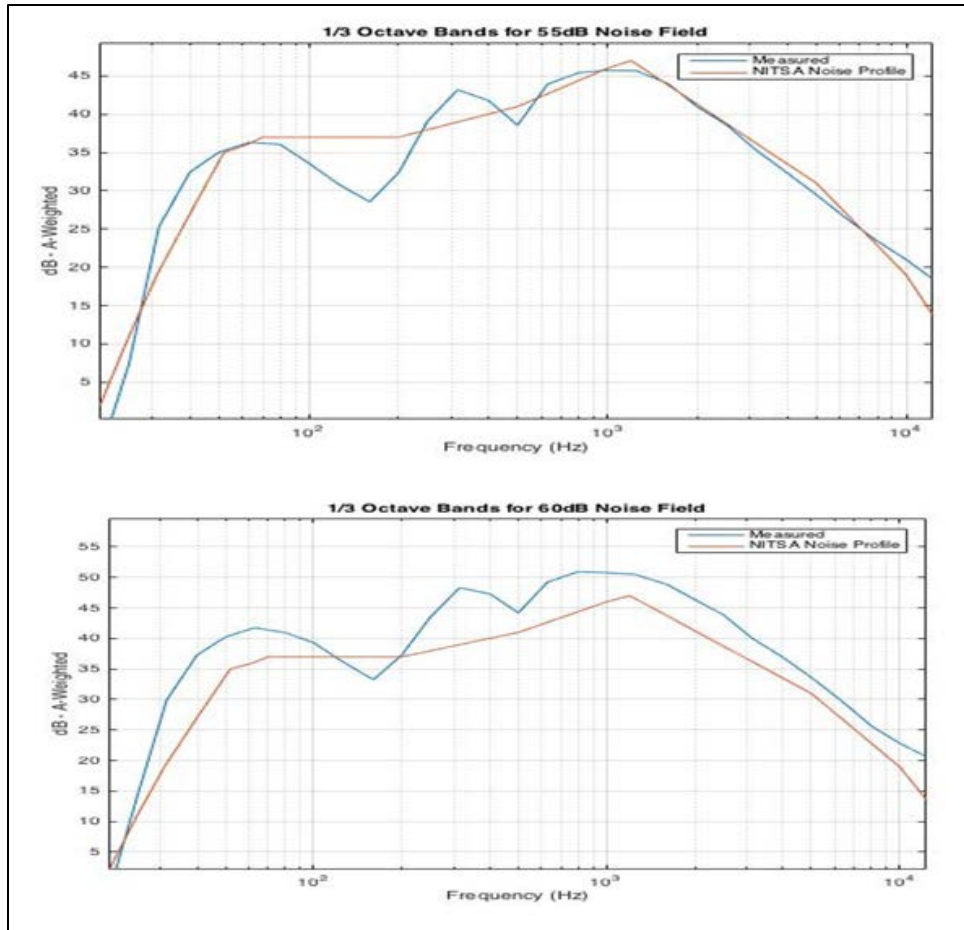

Figure 32. Charts. Average background noise spectrum for 55 dBA (top) and 60 dBA (bottom).

Weather Instrumentation

Due to the potential impact on noise and sound travel, wind was measured and monitored throughout testing, with max wind speed and direction recorded for each trial. An AcuRite 8" professional digital weather center was installed adjacent to the test location, providing accurate wind speed, wind direction, and temperature output, among other measurements (Figure 33). Prior to testing, a criterion of 7 mph was established for maximum wind speed. Potential session dates were frequently cancelled due to higher predicted wind speeds; therefore, wind speed was rarely an issue on days we were able to conduct testing. However, there were times when testing was paused, or trials were repeated, due to a brief increase in wind speed. Although kept to a minimum, wind in some periods of testing did exceed 7 mph where it could not be avoided. Figure 34 illustrates a heatmap of all wind and temperature measurements collected for each trial across all four listener sessions.



Figure 33. Photos. Mounted weather station (left) and digital display (right).

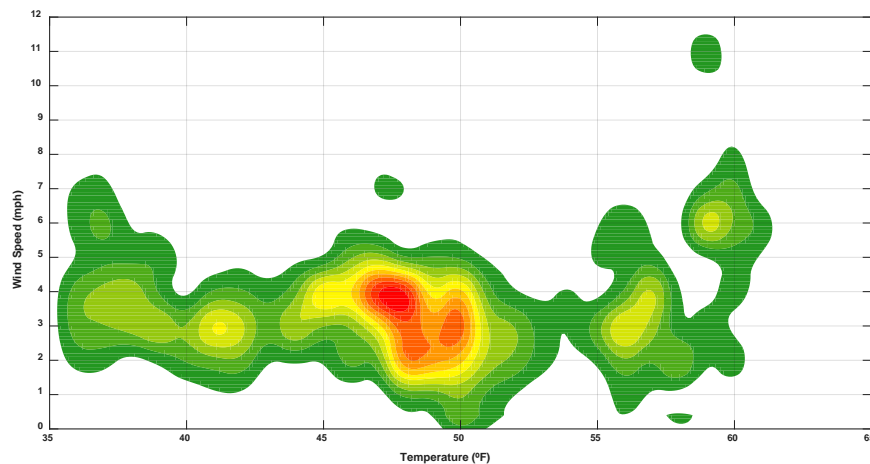

Figure 34. Chart. Heatmap of wind and temperature measurements across all listener sessions.

Dependent Measures

The primary measure of interest was the calculated distance between the approaching vehicle and the static listener at the point of detection. Detection distances presented within the upcoming results section take into account the lateral offset of the participant's seated location relative to the vehicle path; in other words, distances are representative of a true straight-line distance as opposed to perpendicular only.

Direct distance output from the DGPS receiver was provided as a perpendicular measurement based on the relative positioning of the vehicle-mounted antenna and seat 1, as illustrated in the figure below (Figure 35). This perpendicular measurement was first adjusted to account for the vehicle's front bumper, in order to assess distance relative to the nearest point of the approaching vehicle. Corrections were thereafter applied to incorporate both the longitudinal and lateral position of each individual seat relative to the approaching vehicle, providing a true straight-line distance specific to each participant's individual location.

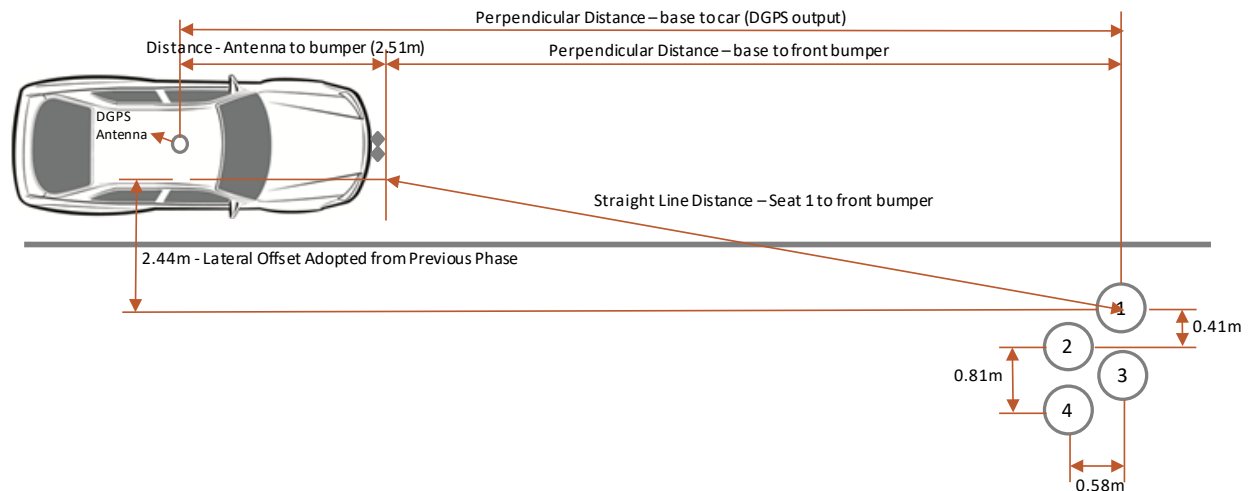

Figure 35. Diagram. Straight line distance calculations.

The second dependent measure assessed whether participants were able to accurately detect when it was safe to cross after the approaching vehicle was fully stopped after slowing to a stop from 20 km/h. This measure represents the time participants released the button relative to when the vehicle had come to a complete stop. For example, if a participant released the button before the vehicle came to a complete stop, this was considered a failed attempt at detecting when it was safe to cross. The ideal response was waiting until the vehicle was at a complete stop before releasing the button.

CHAPTER 3. RESULTS

Results presented herein focus primarily on comparisons across vehicle sound conditions within the targeted noise levels and approach maneuvers. Moreover, detection distances as a whole are compared directly to the “desired detection distances” per NHTSA’s *Minimum Sound Requirements for Hybrid and Electric Vehicles*.^(10; page 109) These distances, specified as 5 m for the 10-km/h approach and 11 m for the 20-km/h approach, are included as reference horizontal straight lines within each forthcoming chart. Importantly, these desired detection distances are based on the ability of an attentive driver to respond and bring the vehicle to a stop, avoiding a collision with a crossing pedestrian.

Each sample-based measurement within this section is accompanied by categorical assessments across individual responses, beyond examining mean detection distances. Specifically, these figures provide critical insight into cases of missed or late detections, which are not perceived within the distance-based averages. Realistically, cases where participants missed a detection, or detected the car at a close distance, indicate a higher potential for collision if making a characteristically representative assessment within a real-world environment.

Furthermore, under conditions where a detection was missed, in the sense that participants never detected an approaching vehicle, a value of 0 m is included within the calculated means. This “penalty” ultimately had little bearing on the relationship across the conditions with an additive sound, but arguably provides a more accurate numeric value when comparing the mean with the desired detection thresholds.

Due to the anticipated improvements in detectability offered by the selected sound conditions, efforts were made to incorporate a longer approach distance between the participants and the point at which the vehicle was to achieve the scenario speed. Even with this increased approach distance, there were a selected number of cases that were excluded from analysis due to “unmet” circumstances. These include, for example, cases where a detection was made before the approaching vehicle reached the targeted speed as well as cases even earlier, where a detection was made before the vehicle sound was initiated (near the turnaround point). In general, care was taken to ensure that outliers were identified and removed, so as not to falsely influence the results.

Approach direction (left vs. right) did not significantly influence detectability. Therefore, all forthcoming charts related to detection distances reflect trials collapsed across approach direction.

DETECTION BY SOUND CONDITION AND APPROACH WITH 55-DBA BACKGROUND NOISE

Mean detection distances within the 55-dBA background noise level by sound condition for both of the steady-speed approach maneuvers are illustrated below (Figure 36). Further examination into differences within each individual maneuver are offered in the text that follows, but this figure provides a direct comparison of how the change in approach speed directly influences detectability. Across the sample, increasing the speed from 10 km/h to 20 km/h netted an increase of detection distances by over twofold, on average, across all sound conditions. Mean detection distances for both approach speeds greatly exceeded the NHTSA criteria proposed for each travel speed (5 m at 10 km/h, and 11 m at 20 km/h) when an additive sound was present. Again, cases of missed detection received a 0-m “penalty” calculated within the provided means.

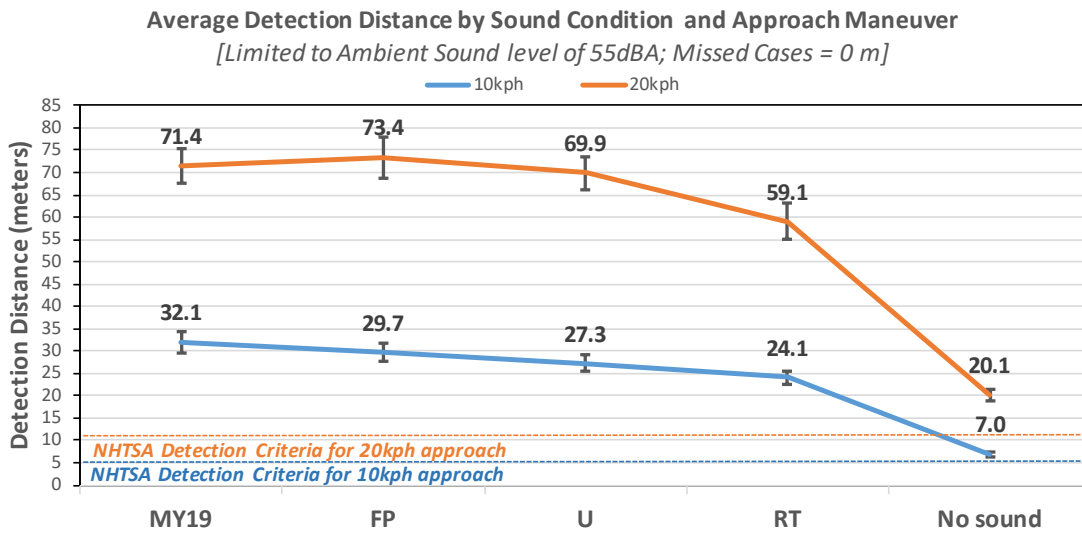

Figure 36. Chart. Average detection distances for steady speed approaches by 55-dB noise level.

As expected, these detection distances are much higher than those observed during the earlier project (Figure 37). Additive sound conditions examined within this effort achieved detection distances approximately twice those observed for the ELR (EV with additive sound) and Prius (hybrid vehicle with additive sound in EV mode), for both approach speeds. In fact, all additive sound conditions outperformed the ICE benchmark (SRX) for both the 10-km/h and 20-km/h approach scenarios. Notably, recorded detection distances for the current baseline (no sound) condition were measurably lower than the previous no-sound vehicle (Volt).

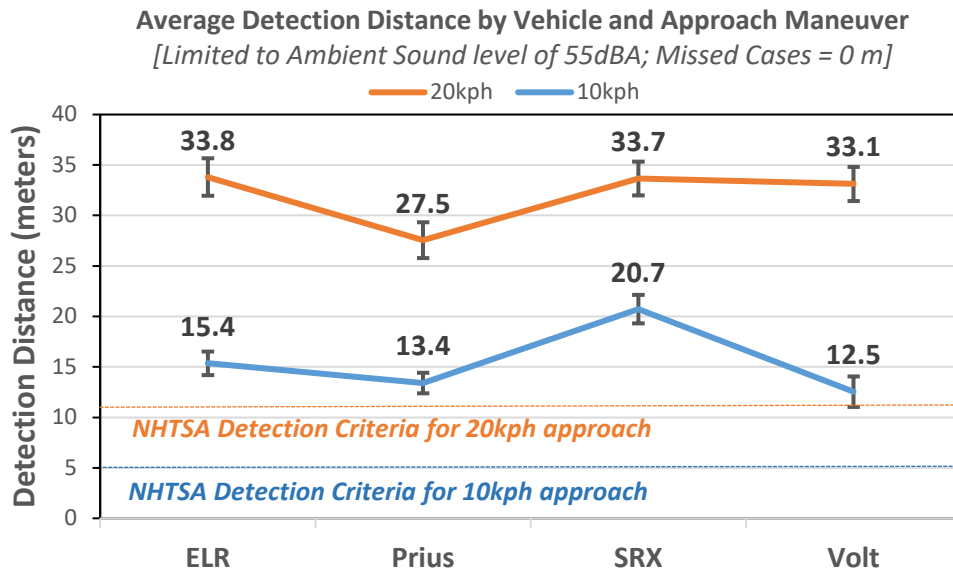

Figure 37. Chart. Average detection distances for steady speed approaches by 55-dB noise level (original phase).

Figure 38 provides average detection distances and corresponding standard error bars for each sound configuration, collapsed across all valid trials where the vehicle approached at 10 km/h under a 55-dBA background noise level. Significance was observed across the sound conditions, with specific differences noted by the post hoc analysis indicators (significant differences exist when there is no overlap across the post hoc letter values—e.g., AB vs. C or D is significant, whereas AB vs. A or BC is not). Clearly, conditions with an additive sound significantly outperformed the no-sound condition, a finding not observed in the earlier project. Significant differences within the additive sound conditions exist as well, with MY19 achieving a significantly higher average detection distance relative to U and RT, and FP significantly higher than RT. It is worth pointing out that, despite recording much higher forward noise measurements, performance was not significantly better for MY19 compared to FP. Notably, all conditions, including baseline, elicited mean detection distances above the NHTSA minimum threshold.

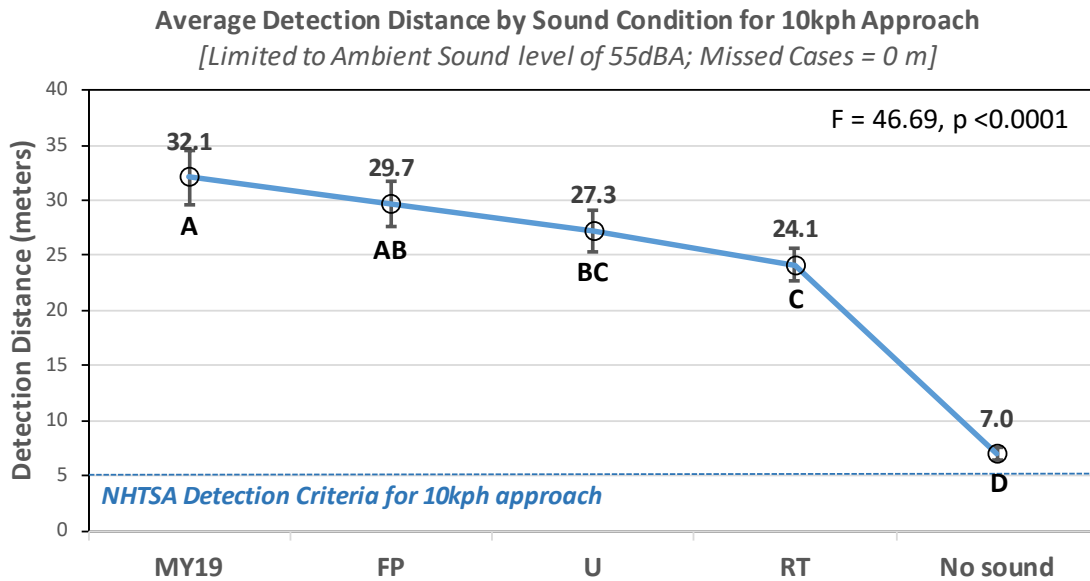

Figure 38. Chart. Average detection distances by sound condition for 10-km/h approach at 55-dBA noise level.

Offering further comparison across the examined conditions, valid cases were binned within one of the following three categories: No Detection (miss), Above NHTSA Criteria (5 m), or Below NHTSA Criteria (5 m). Breakouts by sound conditions are illustrated in Figure 39, again for a steady approach at 10 km/h under a background noise level of 55 dBA. Combining the frequency of misses and detections that occurred below the 5 m detection criteria provides a metric indicative of a possible strike had the pedestrian crossed the road under the presented circumstances. Each sound condition, except for FP, had at least one miss or below-criteria detection, but these were still extremely rare for MY19, U, or RT. Not surprisingly, the no-sound condition elicited the highest number of miss and below-criteria detection points, combining for a possible strike in 30% of all valid trials.

Again, these additive sound conditions outperformed the earlier production variants, as the ELR and Prius recorded a possible strike in 7.1% and 8.5% of all trials, respectively. The SRX (ICE benchmark) recorded a possible strike in 2.9% of all trials. For the no-sound condition, the percentage of possible strikes in this project doubled from an earlier 14.3%, due to an increase in missed detections (up to 20% from 4.3%).

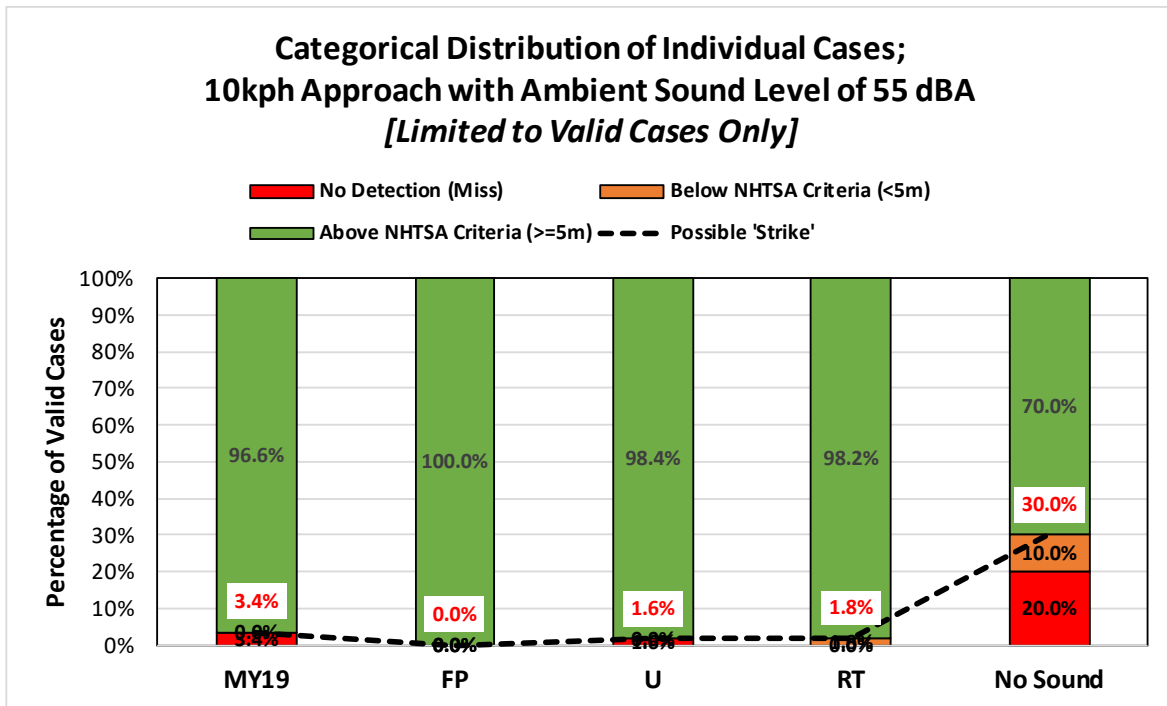

Figure 39. Chart. Distribution of cases for 10 km/h at 55 dBA.

Providing additional insight into individual detection points, the following figure (Figure 40) illustrates the range of observed detection points by sound condition across the valid cases for scenarios approaching from the left and right. Detection points, or clusters thereof, are shown relative to the orange seat icon that represents where the participants were seated. Areas with a red center indicate a higher density of detection distances within that zone. In line with the previous figures, this figure reveals the close proximity of detection button presses made by participants for the no-sound condition, whereas detection points spread further out when an additive sound is included during approach. Performance is generally consistent from left to right (detection distances were not significantly different by approach direction).

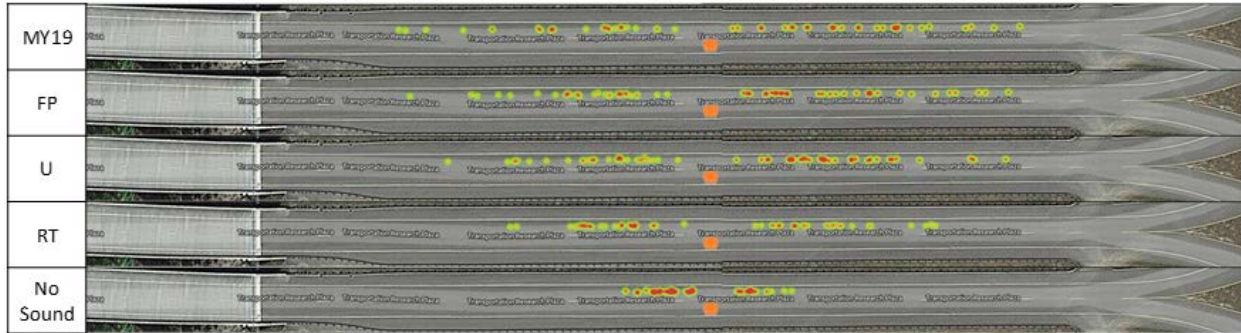

Figure 40. Heat maps. Detection heat maps for 10 km/h at 55 dBA.

Figure 41 provides mean detection distances by sound condition for the 20-km/h steady approach under a 55-dBA background level. As noted previously, detection distances increased dramatically relative to those observed for 10 km/h, indicative of the additional road noise provided by the tires and increased sound levels at higher speeds (sound shifting). As with the 10-km/h approach, all conditions with an additive sound significantly outperformed the no-sound condition, again by a margin of nearly 3:1 or greater. Within the additive sound conditions, MY19, FP, and U all achieved significantly higher detection distances compared to RT, but were not significantly different from each other. Again, all conditions, including no-sound, elicited mean detection distances well beyond the NHTSA minimum criteria.

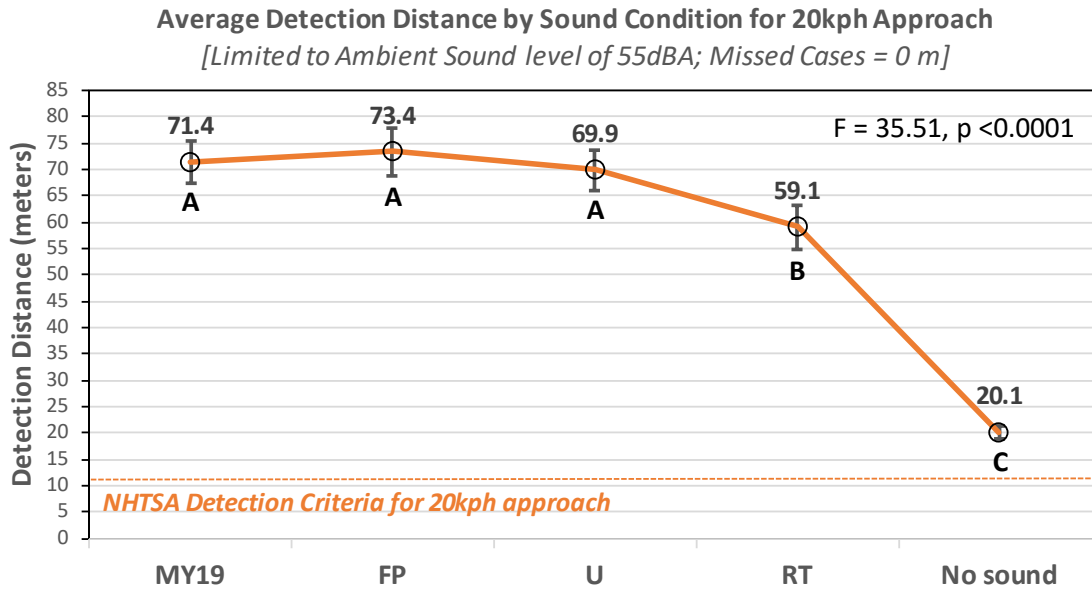

Figure 41. Chart. Average detection distance by sound condition for 20-km/h approach at 55 dBA.

Not surprisingly, the increase in road/tire noise and vehicle sound levels at the higher travel speed dramatically reduced the likelihood of a possible strike, as calculated based on the combined miss and below-criteria cases (Figure 42). None of the valid cases included a missed detection or a below-criteria detection for any of the four additive sound conditions. The ELR and the Prius still recorded 4.3% and 6.0% cases of a possible strike, respectively, during the original evaluation. For the no-sound condition, cases falling within this calculated dilemma zone dropped from 30% to 12.1% at the higher travel speed.

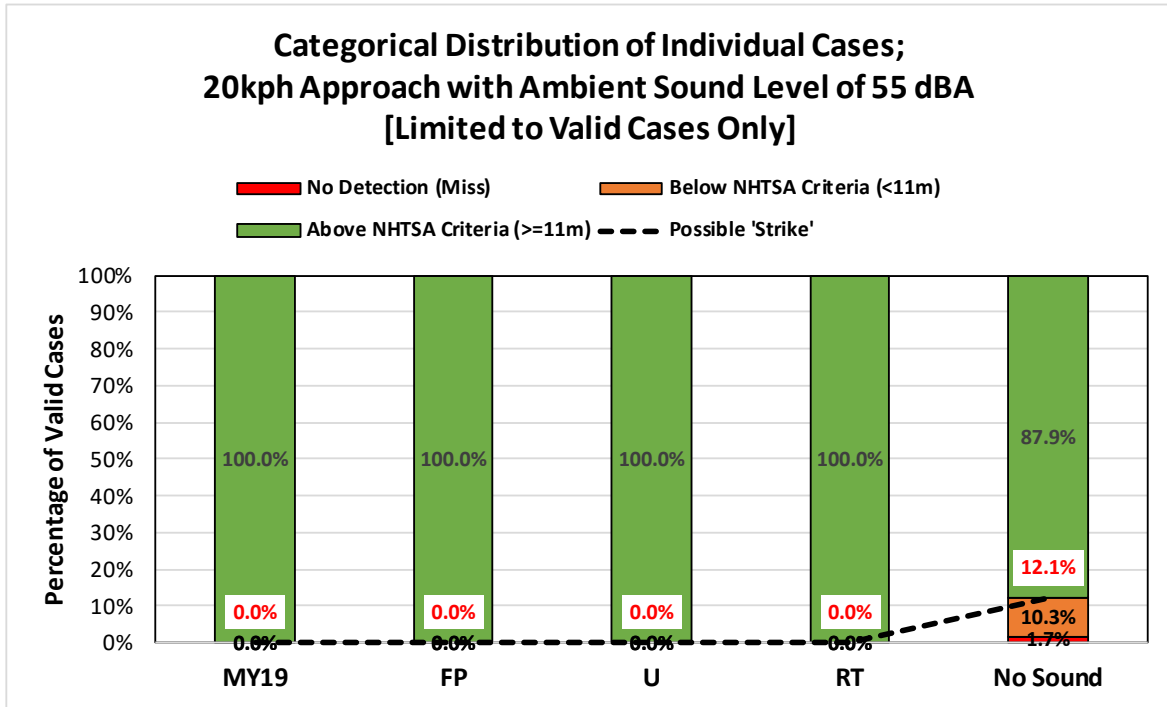

Figure 42. Chart. Distribution of cases for 20 km/h at 55 dBA.

Heat maps again illustrate the distribution of detection distances for each sound condition (Figure 43). Compared to the 10-km/h steady approach, detection distances for all conditions extend farther outward, while the no-sound condition still shows closer grouping relative to where the participants were seated.

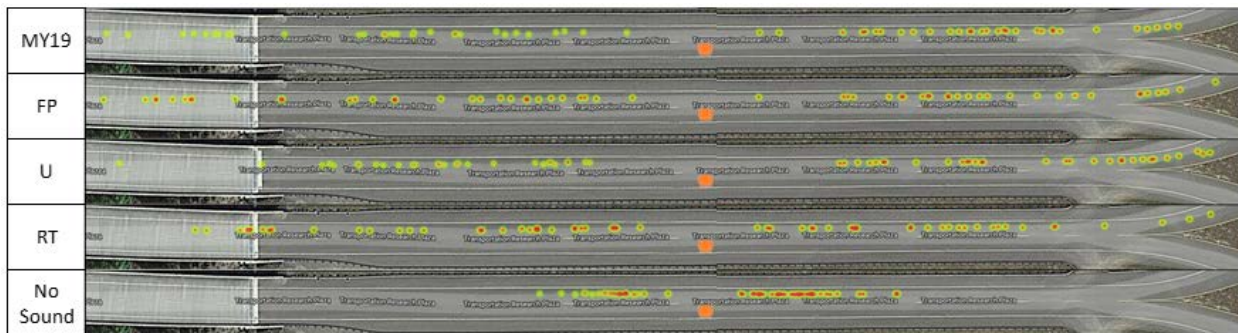

Figure 43. Heat maps. Detection heat maps for 20 km/h at 55 dBA.

DETECTION BY SOUND CONDITION AND APPROACH WITH 60-DBA BACKGROUND NOISE

In line with expectations, increasing the background noise negatively impacted detection distances. The following figure (Figure 44) illustrates how trends observed across both the 10-km/h and 20-km/h steady approach scenarios under the 55-dBA background noise remained relatively stable with the increase to 60 dBA, albeit proportionally reduced. Across the sample as a whole, detection distances fell approximately 33% for the 10-km/h approach, ranging from a low of 26% for the baseline to a high of 43% for RT. Similarly, the overall percentage drop in detection distances for 20 km/h was approximately 28%, with a low of 18% for U and a high of 40% for RT.

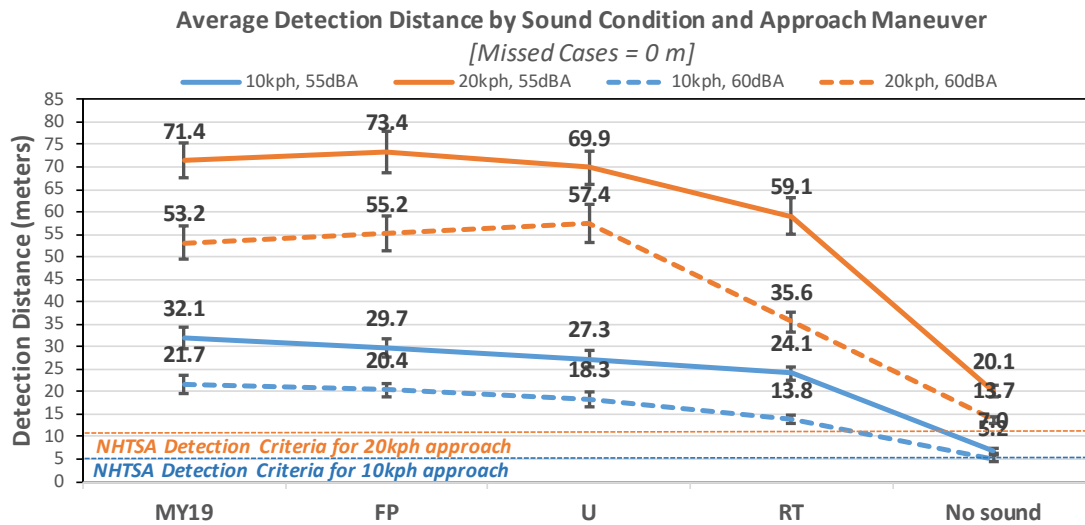

Figure 44. Graph. Average detection distances by sound condition for both steady-speed approaches at 55 dBA vs. 60 dBA.

As with the lower background noise level, the overall separation between the baseline and the other four additive sounds remains significant for 10 km/h at 60 dBA (Figure 45). Less separation exists between the additive sound conditions, with MY19, FP, and U significantly outperforming RT, and similar to each other. Again, the average detection distances for conditions with an additive sound are still well above NHTSA’s minimum, while the no-sound condition achieves a mean just above the criteria.

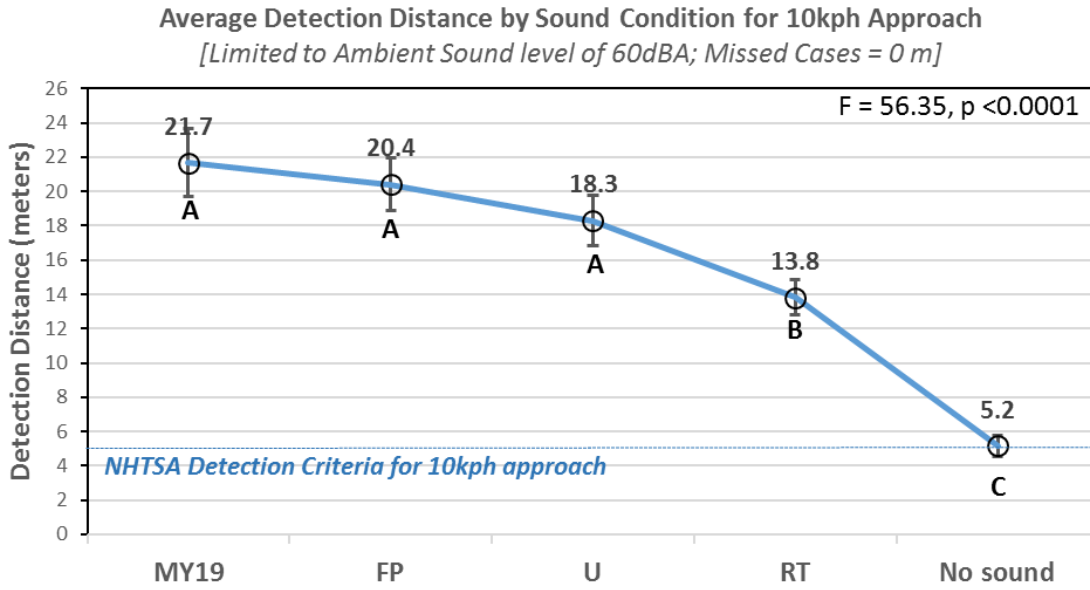

Figure 45. Chart. Average detection distance by sound condition for 10-km/h approach at 60 dBA.

The differences between the two noise levels become even more apparent when examining the frequency of detections that missed or fell below the desired criteria (Figure 46). For most conditions, the percentage of “possible strike” cases increased dramatically within the noisier environment. FP saw the smallest increase, from 0% to 1.6%. Of the additive sound conditions, the largest change was observed for RT, which increased from 1.8% to 10.2% (increase in magnitude of 5.7). MY19 and U increased by 3 and 3.2 times, respectively. For the baseline, more than half of all valid cases (55%) occurred within this dilemma zone, increasing from 30% under the lower background noise level. Heat maps are provided in Figure 47.

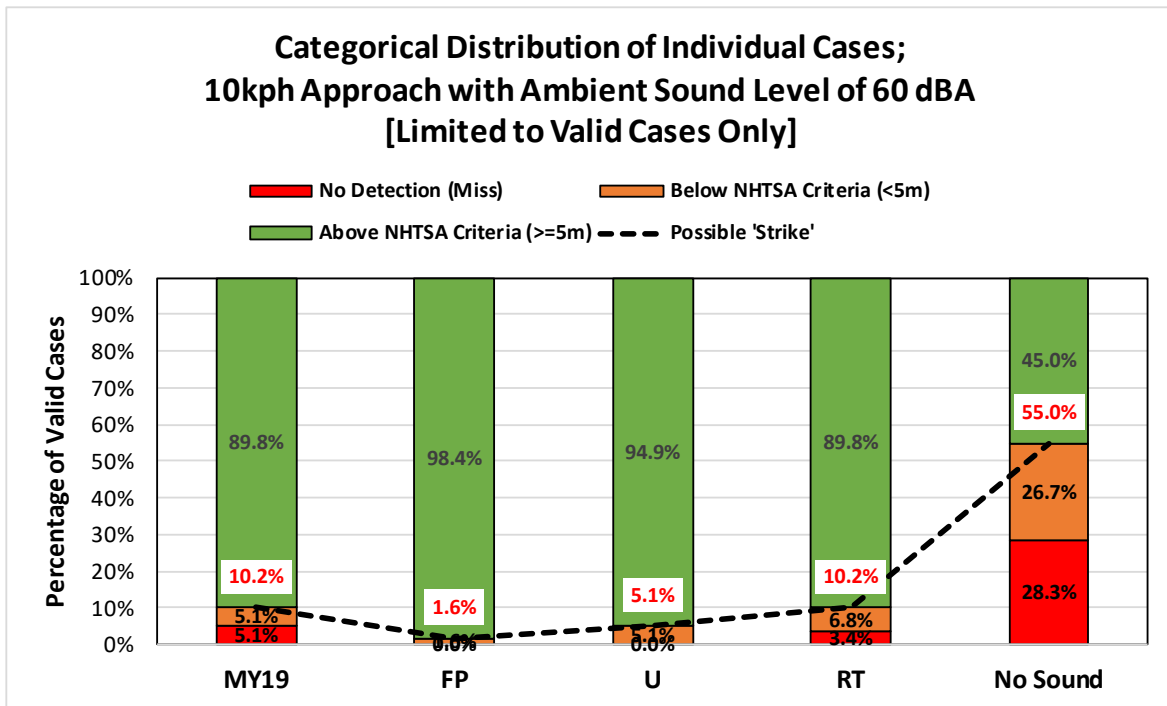

Figure 46. Chart. Distribution of cases at 10 km/h and 60 dBA.

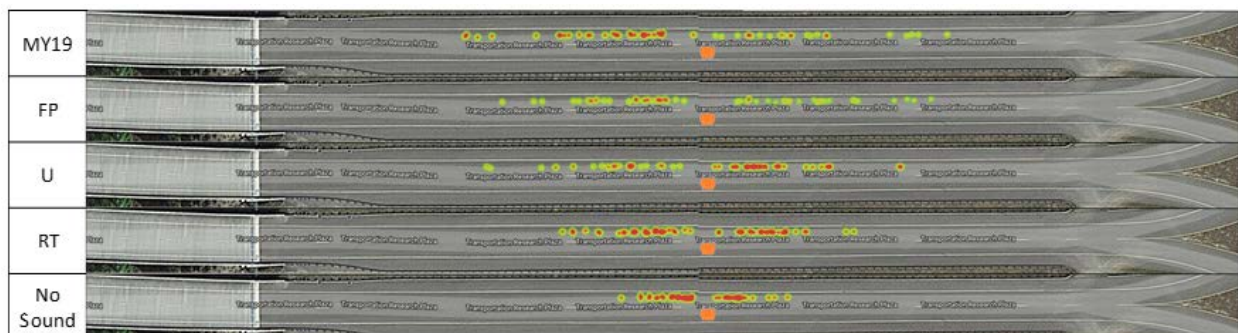

Figure 47. Heat maps. Detection heat maps for 10 km/h at 60 dBA.

The trend continues for 20 km/h under 60 dBA, with similar differences across sound conditions as observed under 55 dBA (Figure 48). Again, a clear separation exists between all sound conditions and the baseline, while MY19, FP, and U all significantly outperform RT, but are not significantly different from each other. All sound conditions are well above the NHTSA minimum, while the baseline again exceeds but hovers close to the minimum criteria.

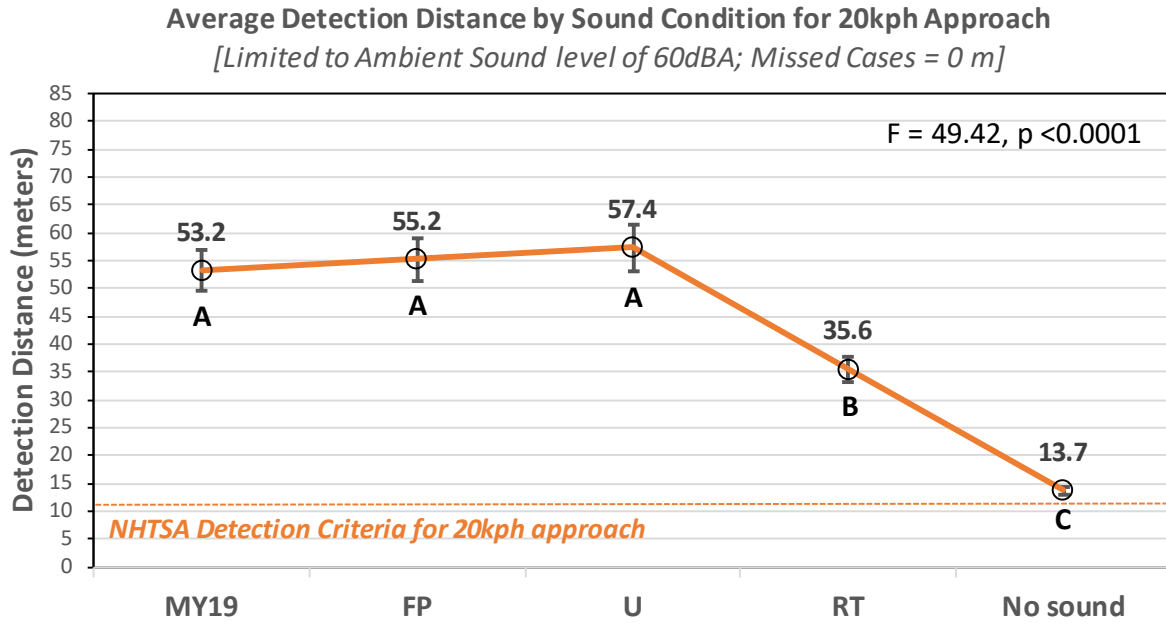

Figure 48. Chart. Average detection distance by sound condition for 20-km/h approach at 60 dBA.

Although the number of missed cases remained low for the 20-km/h approach, a measurable increase in the number of detections that occurred below the 11 m criteria (Figure 49) was observed for MY19 and the no-sound condition within this noisier environment, compared to the same scenario under 55 dBA. For MY19, detections went from 0% to 3.2%, while the number of possible strike cases increased almost 3 times (from 12.1% to 31.0%) for the baseline condition. Dilemma zone detections were absent for FP, U, and RT. Heat maps are provided below (Figure 50).

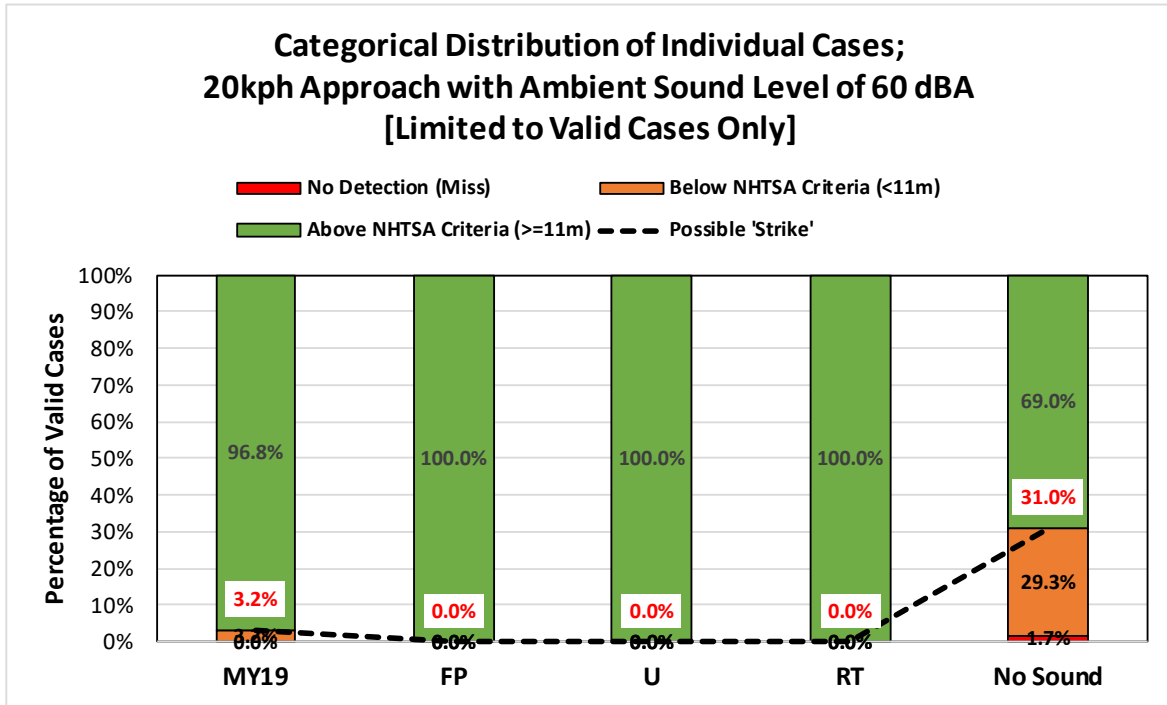

Figure 49. Chart. Distribution of cases at 20 km/h and 60 dBA.

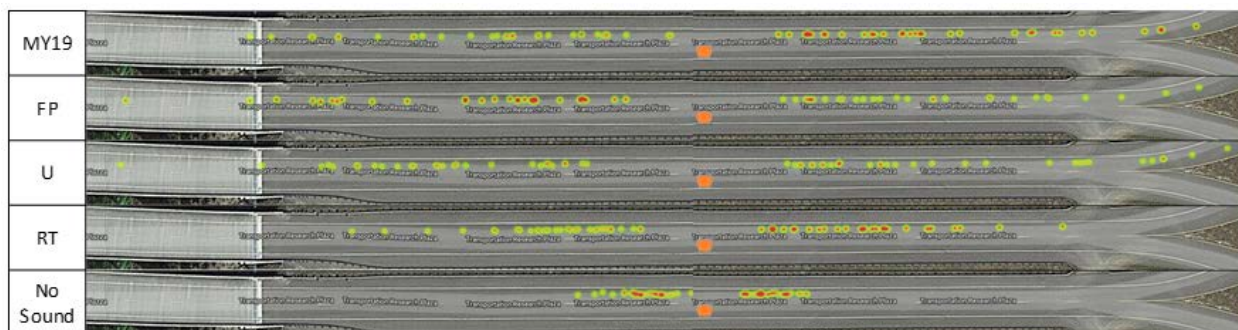

Figure 50. Heat maps. Detection heat maps for 20 km/h at 60 dBA.

SAFE TO CROSS (RECOGNITION OF STOPPED VEHICLE)

As a reminder, participants indicated their perceived “safe to cross” point following initial detection of the approaching vehicle by releasing the handheld button. Analysis focused on each participant’s ability to correctly identify that a vehicle had stopped directly in front of their location. As such, discussion regarding this metric is herein limited to the scenario in which vehicles approached at 20 km/h before gradually decelerating down to 0 km/h. Again, vehicles remained stationary for 5 s before continuing.

The following charts illustrate the accuracy of these responses, under both the 55-dBA and 60-dBA noise levels. Based on timing relative to when the vehicle truly stopped, responses were categorized as follows:

- **Miss:** for cases where there was no detection, there was no release point indicating recognition of a stopped vehicle
- **Late:** detection during approach, but button release occurred after the vehicle started moving again (>5 s)
- **Early:** indicative of button release before the approaching vehicle came to a complete stop
- **While Stopped:** indicative of button release following vehicle stop, but before vehicle continued forward (within 5 s); ideal response

Recognizing that an approaching vehicle came to a complete stop after slowly decelerating proved difficult in the earlier project, with participants releasing the button early across approximately 28% of all recorded scenarios. Consistent behavior was observed for conditions examined during this round of testing (Figure 51). For reference, Figure 52 provides the safe-to-cross findings from the earlier project. As shown, the Prius outperformed the other conditions, which was believed to be the result of the additive sound turning off when the vehicle stopped, while the sound in the ELR was present any time the transmission was in drive or reverse gears, regardless of vehicle speed. Ultimately, performance for the additive sounds herein was comparable to the ELR, with correct recognition of a fully stopped vehicle happening most of the time, but still falling between 61% and 70% (no significant differences). The remaining cases consisted of missed detections, for which there was no corresponding release, and button release points after the vehicle began to reaccelerate following the 5-s stop. The majority of cases for the no-sound condition (54.7%) were early, with a higher percentage of missed and late responses compared to the sound conditions.

Unlike detection during approach, direction (left vs. right) revealed itself as a significant factor for safe-to-cross recognition under a 55-dBA background (Figure 53), but not at 60 dBA. Overall, the rate of correct recognition was higher during trials where the vehicle approached from the right. Although not believed to have influenced detection results, this finding may be partially explained by the generally better right ear performance during the hearing test across the participant sample (see hearing results in Appendix E). Latency for cases where participants correctly recognized this safe-to-cross point was not significantly different across all conditions examined.

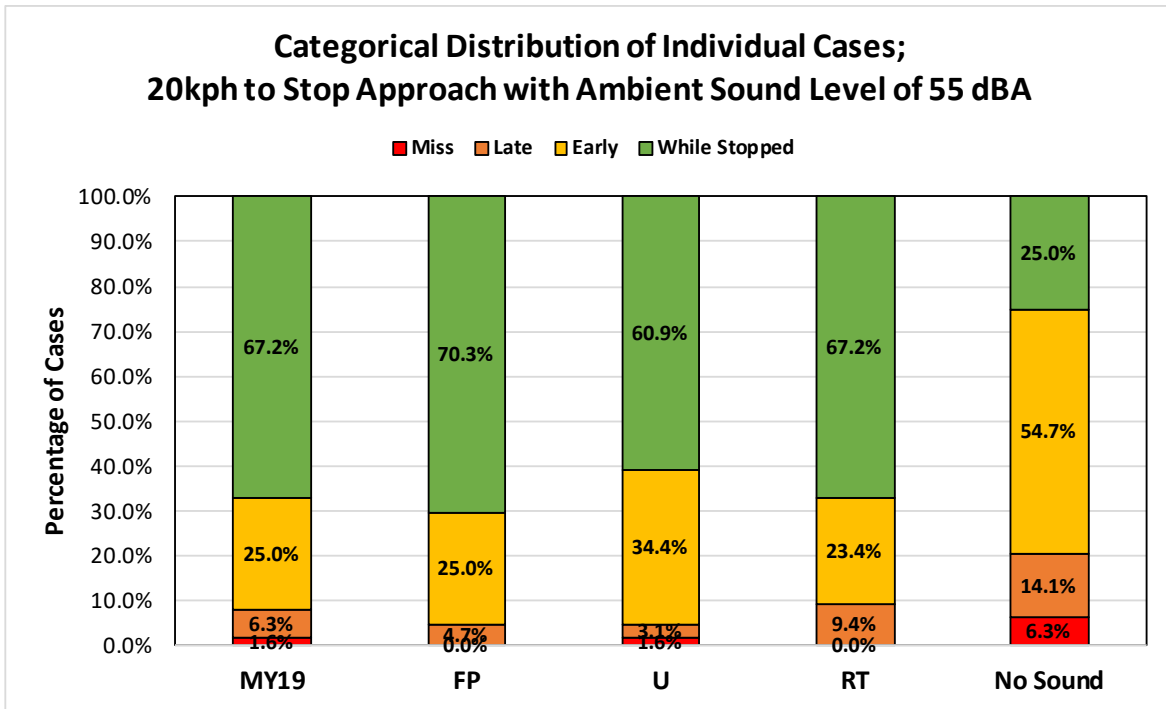

Figure 51. Chart. Safe to cross categorical responses at 55 dBA.

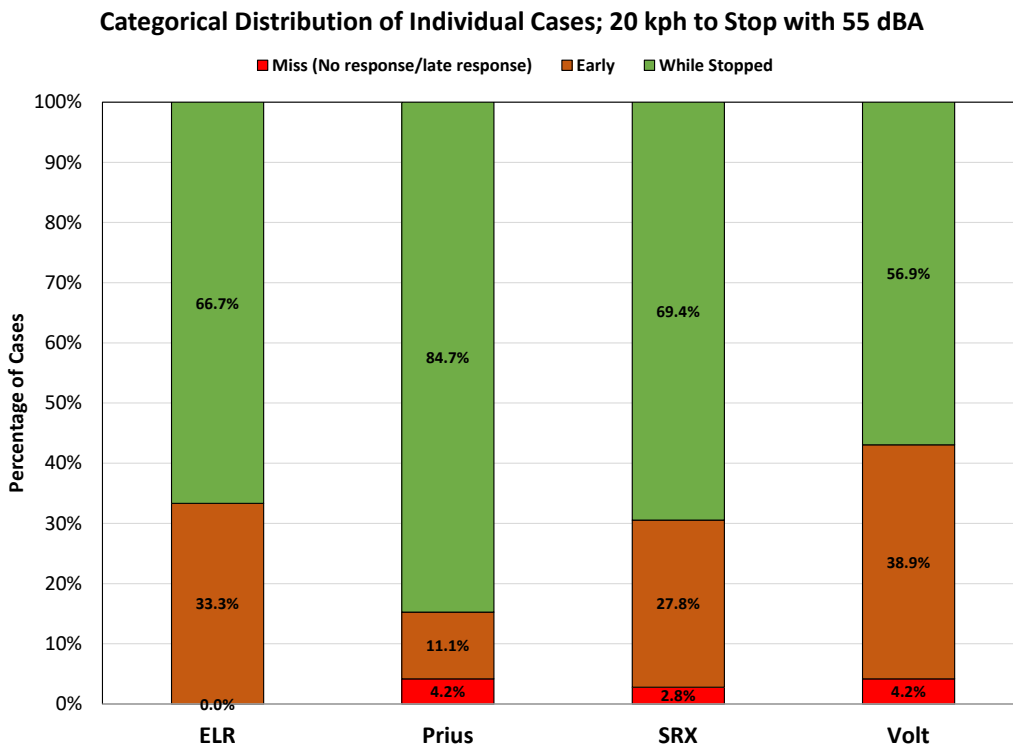

Figure 52. Chart. Safe to cross categorical responses at 55 dBA for original study.

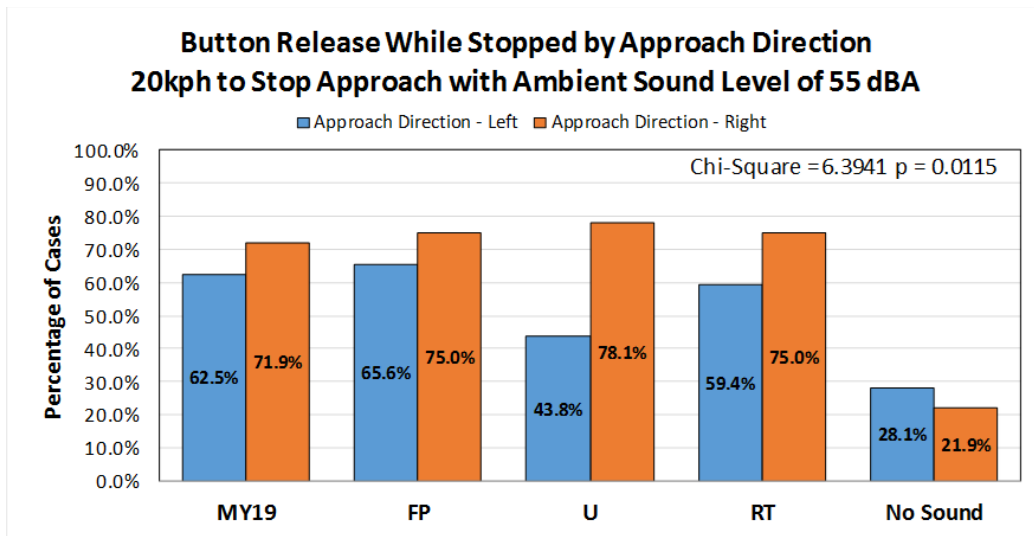

Figure 53. Chart. Percentage of correct “safe to cross” responses by approach direction at 55 dBA.

Correct recognition of a vehicle at rest remained relatively stable for the four additive sound conditions when increasing the background noise (Figure 54), with the majority of accurate cases still falling in the 60% to 69% range (no significant differences). The biggest change with the increased background noise was observed for the no-sound condition, where late responses increased from 14.1% to 37.5%. This result indicates the increased difficulty of accurately assessing vehicle state as a pedestrian in a noisy environment without the aid of an additive sound solution.

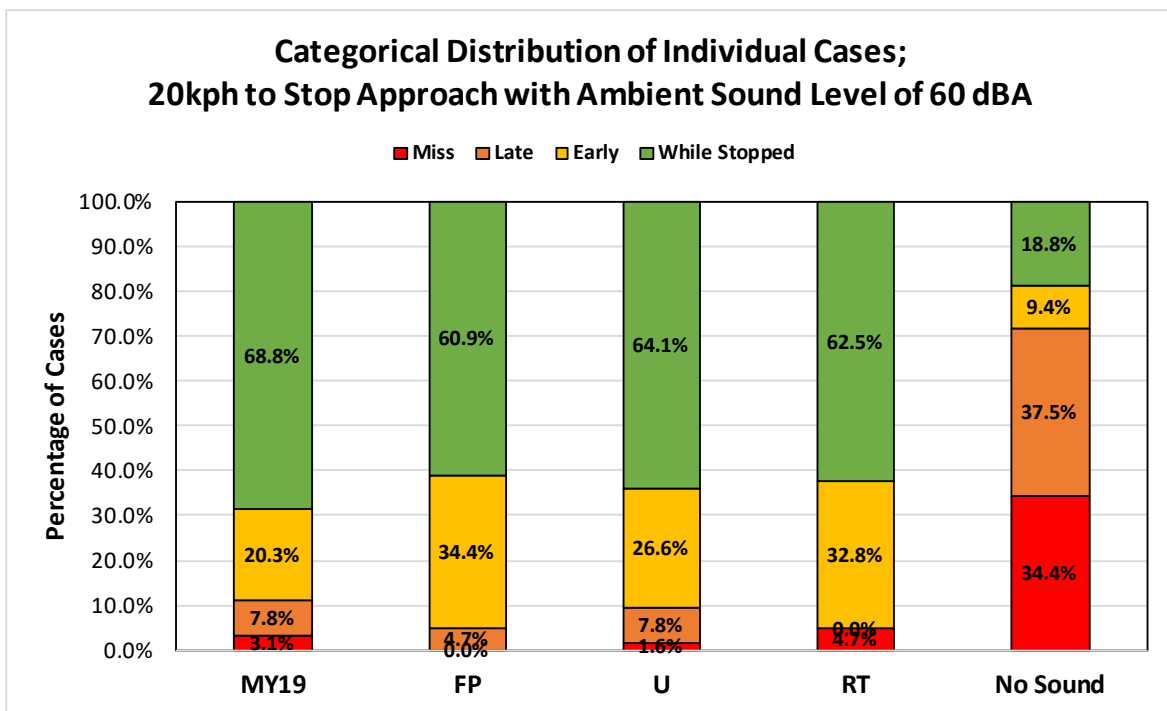

Figure 54. Chart. Safe to cross categorical responses at 60 dBA.

POST-DRIVE QUESTIONNAIRE

As previously noted, participants completed a short questionnaire capturing responses for each of the sound conditions they experienced during testing. Responses, collapsed across all participants, are summarized in the following figures. Simplifying response outcomes for the closed-ended questions further, recorded responses were collapsed across the 7-point scale as follows:

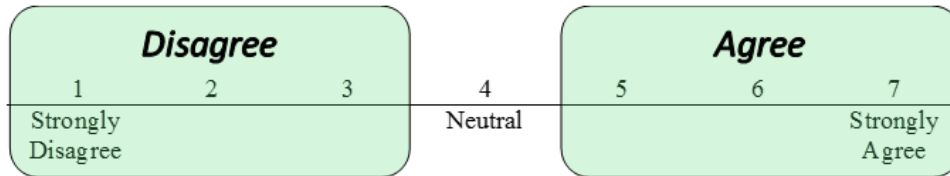

Figure 55. Diagram. Seven-point scale for participant questionnaire responses.

After the experimenter played a 20-s loop of the sound file, participants were first asked whether they felt the sound was appropriate for EVs. As shown in Figure 56, agreement was generally high across the board. MY19 achieved the highest overall agreement, with 75% of participants recording a 5–7 on the 7-point scale, followed by 63% for FP, and 56% for both U and RT. On the disagreement side, RT recorded the highest percentage at 38% (response of 1–3), while the other three conditions were comparable at 19%.

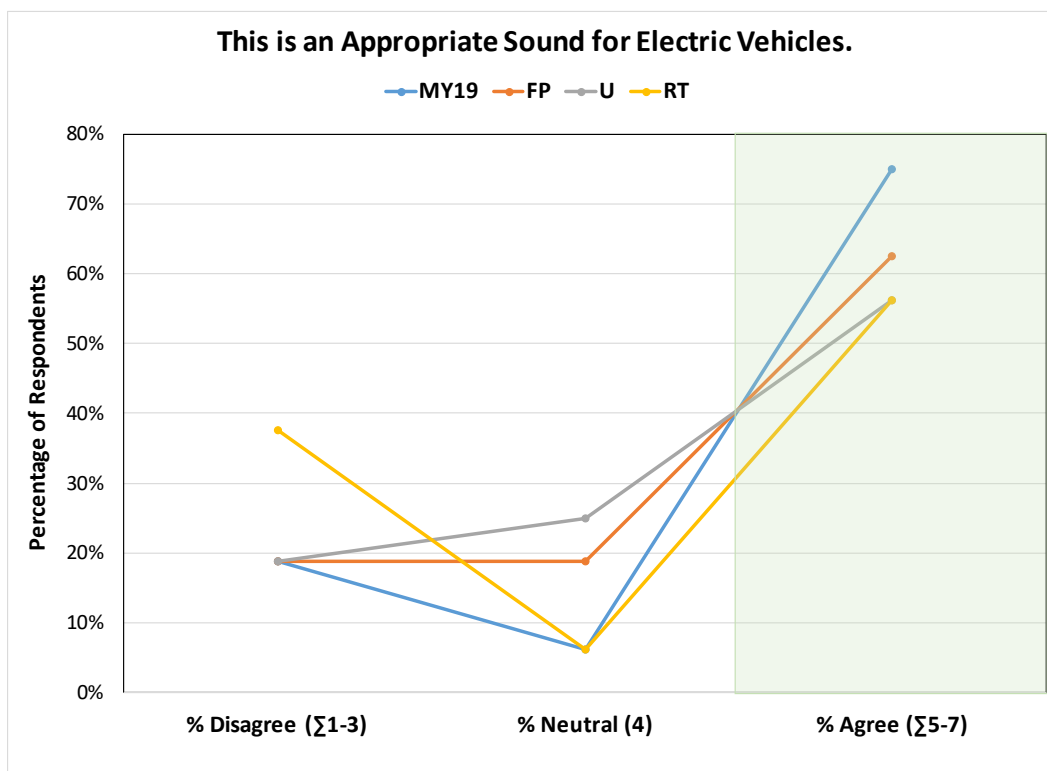

Figure 56. Chart. Post-drive Questionnaire Q1 – appropriateness.

Compared to no additive sound, each sound condition achieved high overall agreement that its inclusion would make it easier for pedestrians to detect approaching EVs (Figure 57). Nearly all participants (94%) agreed that MY19 would make it easier to detect EVs, followed by RT at 88%, FP at 81%, and U at 69%. Disagreement was nearly nonexistent, with the remaining percentages largely falling neutral.

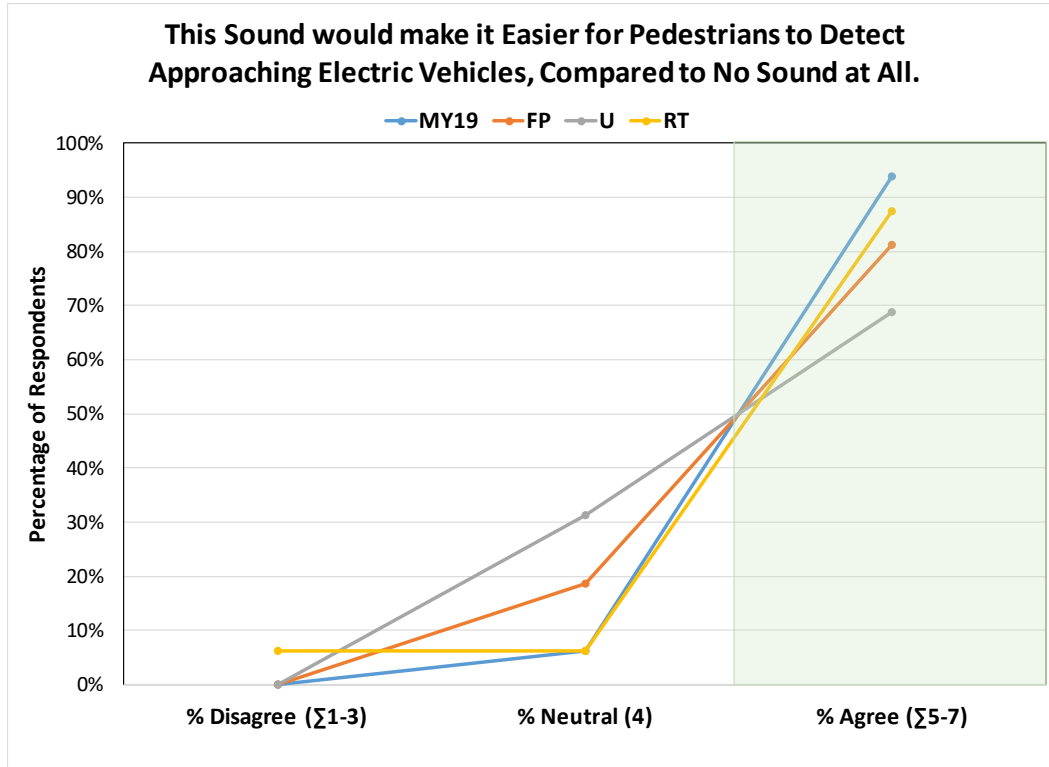

Figure 57. Chart. Post-drive Questionnaire Q2 – easier to detect.

Although not rated as highest for appropriateness, RT’s unique signature compared to the other additive sounds was recognized for its ability to effectively communicate that an EV is approaching, achieving agreement across 75% of the participant sample (Figure 58). FP and MY19 were tied at 69%, with U receiving the lowest agreement at 56%.

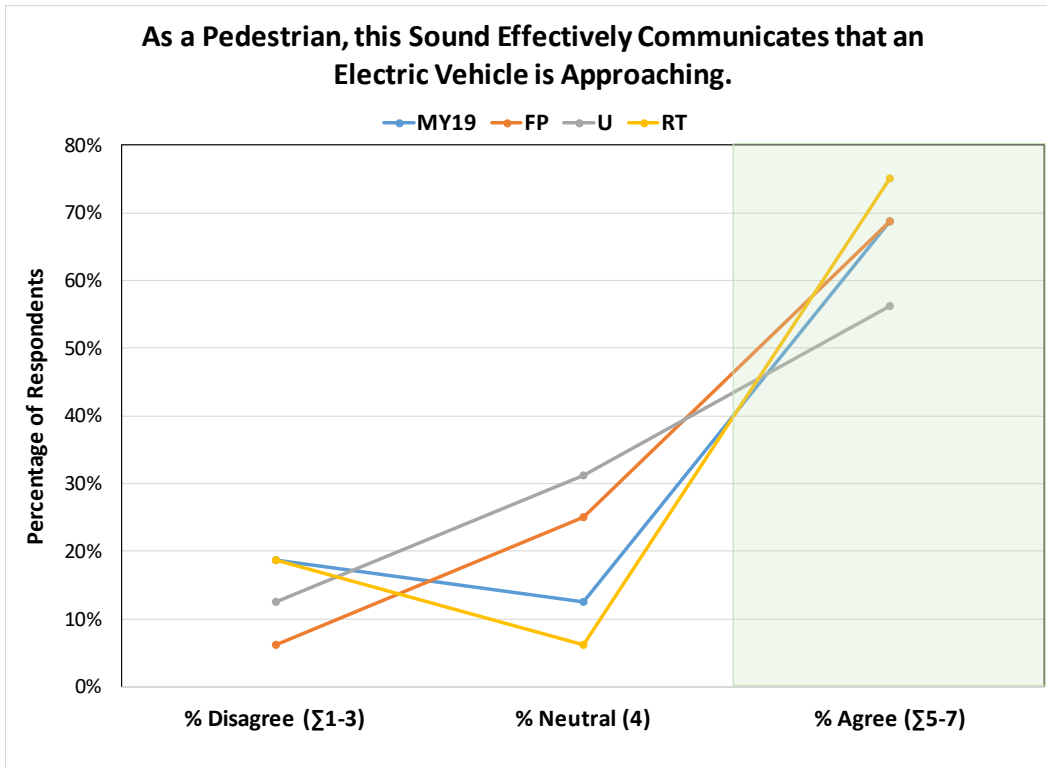

Figure 58. Chart. Post-drive Questionnaire Q3 – effectively communicates approaching EV.

In terms of perceived safety (Figure 59), both MY19 and RT achieved identical responses. All but one participant (94%) in each case agreed that the inclusion of these additive sounds increases safety (no disagreement). High agreement was also recorded for U (81%) and FP (75%).

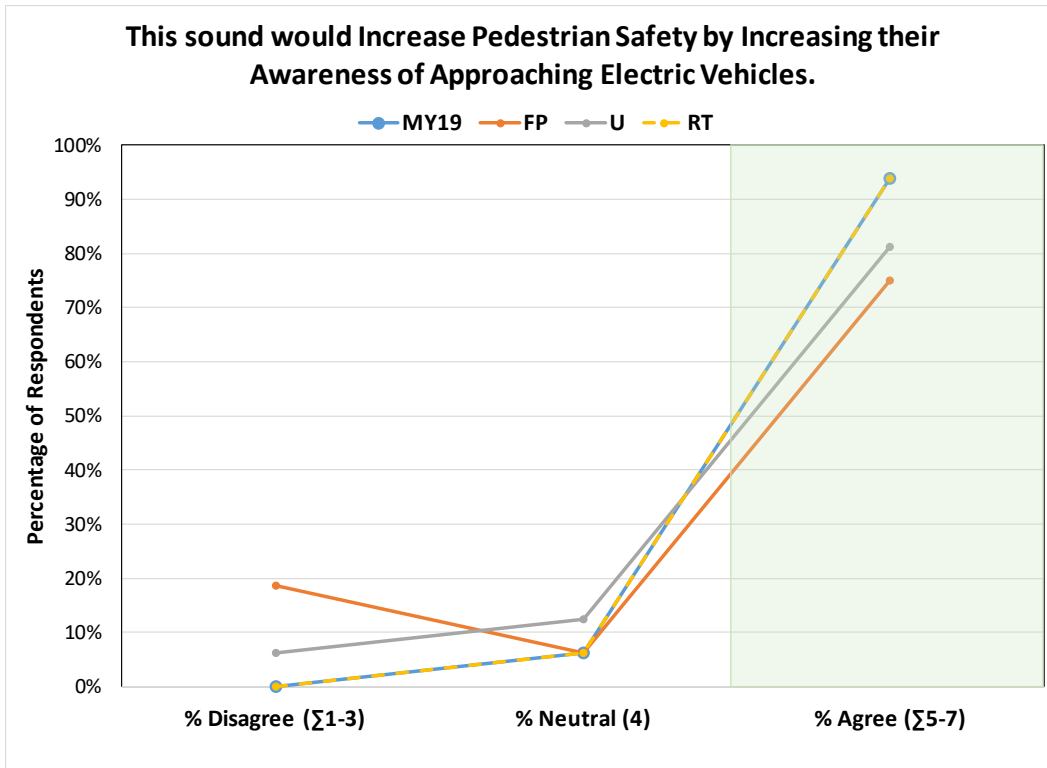

Figure 59. Chart. Post-drive Questionnaire Q4 – increases pedestrian safety.

On the opposite end of the spectrum, participants were asked to provide feedback on whether they believed the sounds would be an annoyance if used by EVs (Figure 60). Approximately 63% disagreed with this statement when referencing the FP sound, while only 6% felt it would be annoying. For U, 50% disagreed that it would be annoying, while only 19% thought it would be annoying. Separately, both the MY19 and RT sounds received higher agreement of annoyance, at 56% and 50%, respectively, which is interesting considering earlier high marks in terms of perceived appropriateness and safety impact provided by these sounds.

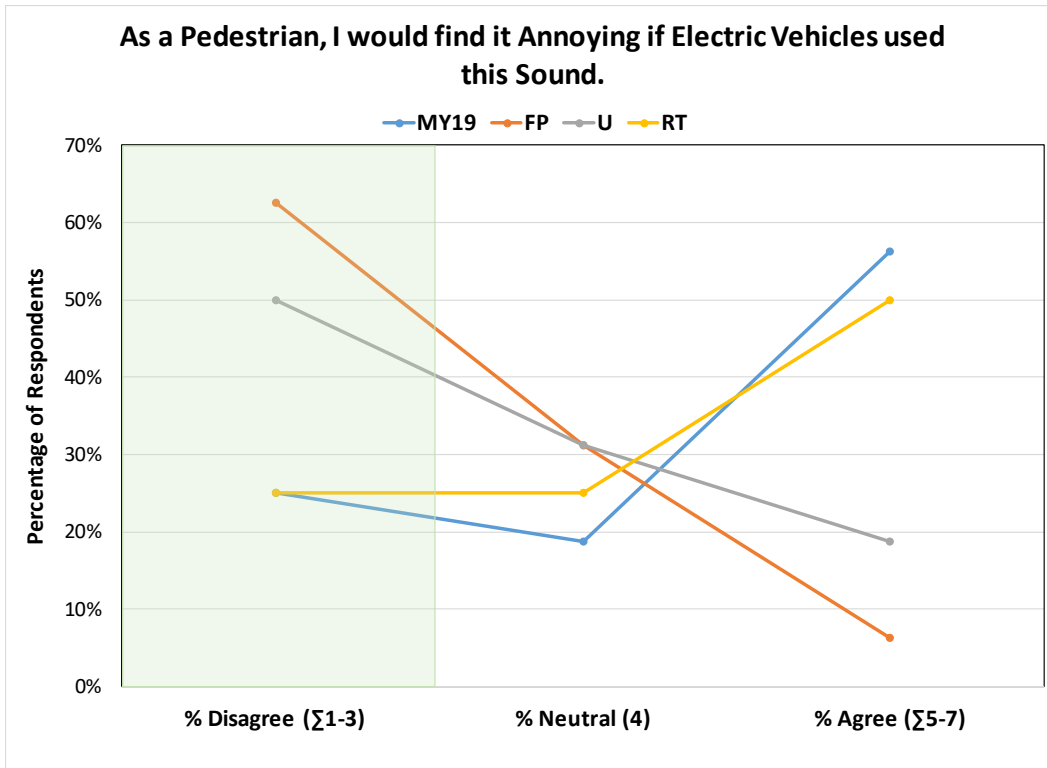

Figure 60. Chart. Post-drive Questionnaire Q5 – annoying.

CHAPTER 4. CONCLUSIONS

The proposed additive sounds examined herein drastically improved detectability compared to the production variants included in the first round of testing. Before, at 10 km/h, the EV and hybrid vehicle with additive sounds showed a trending, yet non-significant, improvement in detectability over the no-sound condition. Here, additive sound conditions outperformed the no-sound condition by magnitudes ranging from 3.4 to 4.6, each eliciting mean detection distances well above the NHTSA minimum detection criteria. Some differentiation was revealed across the additive sound conditions; MY19 achieved the highest mean detection distance, but was not significantly better than FP, despite having an approximately 5 dBA higher overall SPL maximum during the FMVSS testing (refer to Dynamic Measurement Results for 10 and 20 km/h in Vehicle Noise Testing). RT achieved the lowest mean detection distance across the additive sound conditions, but still drastically outperformed the no-sound condition. Possible strikes based on missed or close detections were rare, but not entirely absent for the additive sound conditions (none observed for FP). Comparatively, approximately 30% of trials for the no-sound condition fell within this possible strike window.

At 20 km/h, detectability also improved dramatically over the earlier production variants, achieving a similar magnitude advantage over no-sound as observed at 10 km/h. Differentiation among the additive sound variants lessened, with only RT being significantly lower than the other additive noise conditions. Again, it is important to note that MY19 was considerably louder than any other condition at the front yet did not perform significantly better, indicating that the other noise conditions are similarly effective (excluding RT) at lower overall sound levels. Importantly, “possible strikes” were absent for all additive sounds at this higher speed, yet still possible in 12% of all no-sound trials.

As expected based on observations from the earlier study, increasing background noise resulted in a measurable impact on mean detection distances. The average reduction across all conditions was approximately 33% and 28% for approach speeds of 10 km/h and 20 km/h, respectively. Although reduced, overall performance across the conditions was relatively stable. For both the 10-km/h and 20-km/h approach scenarios, RT elicited the lowest mean detection distances across the sound conditions; the other three sound conditions were not significantly different from each other. The louder background noise increased frequency of possible strike cases for all conditions at 10 km/h, while only MY19 and the no-sound condition were impacted at 20 km/h.

In terms of accurately recognizing a stopped vehicle in the 20–0 km/h scenario, all sound conditions significantly outperformed the no-sound condition across both background noise conditions. The majority of cases with an additive sound present elicited a correct button release within the 5 s during which the vehicle was stopped, while the majority of the remaining cases were deemed early (before the vehicle came to a complete stop). Alternatively, the majority (54.7%) of cases in the no-sound condition were early. Early release points are of greatest concern since pedestrians may falsely assume a vehicle is stopped when it is still moving, albeit slowly in this context.

Subjective feedback was largely positive throughout, with MY19 receiving the highest ratings for appropriateness, ease of detection, and increasing pedestrian safety (tied with RT). Perhaps

most revealing, however, was that MY19 also received the highest rate of agreement for perceived annoyance, whereas FP received the lowest agreement.

CLOSING THOUGHTS

Clearly, these new additive sounds elicited dramatic improvements in detectability and reduction in “possible” strike cases compared to early production variants examined in the original study. All additive sounds achieved mean detection distances well above the NHTSA minimum. GM’s desire to set these sounds at a loudness level beyond the FMVSS minimum certainly improved performance. Within this testing, it is uncertain what level of reduction in detectability would be expected for sound profiles that meet the basic FMVSS criteria.

Performance across the sound conditions was generally comparable, particularly between MY19, FP, and U. This result illustrates the effectiveness of both the FP and U signals, despite the fact that they were quieter in front relative to MY19. RT underperformed compared to the rest of the conditions, but still provided a tremendous advantage over the no-sound condition. These results suggest that flexibility exists in terms of what types of sounds are effective, as the sound design in these four conditions’ design varied.

The location of a production speaker may also impact the results observed herein, as it is uncertain whether or not a speaker will be located at front center. The tested arrangement emphasized consistent directionality to the front and on the driver and passenger side, whereas previous testing revealed differences in passenger versus driver-side measurements due to speaker location.

APPENDIX A. PHONE SCREENING QUESTIONNAIRE

Phone Screening Questionnaire

Note:

Initial contact between participants and researchers may take place over the phone. If this is the case, read the following Introductory Statement, followed by the questionnaire. Regardless of how contact is made, this questionnaire must be administered verbally before a decision is made regarding suitability for this study.

Introductory Statement:

After prospective participant calls or you call them, use the following script as a guideline in the screening interview.

Hello. My name is _____ and I'm with the Virginia Tech Transportation Institute, in Blacksburg, VA. We are currently recruiting eligible individuals to participate in a research study assessing detectability of approaching vehicles within a simulated intersection environment. You won't be asked to drive during this study, and testing will take place outdoors. Specifically, participants will be asked to identify the first point of detection with respect to approaching vehicles, as well as the point at which the approaching vehicle has passed and is no longer a threat. Participants will be asked to perform assessments from the point of view of a pedestrian who is attempting to cross the street, although participants will remain stationary throughout the test session. This study would involve coming to our facility for a single day-long (7 hours) session. This session will include two, 2.5 hour, evaluation blocks within the simulated intersection environment; one in the morning and one after lunch. There will be several breaks, and lunch and snacks will be provided as part of participation. You will participate with 3 other participants. An experimenter will be with you at all times. <Note to screener: they will not be allowed to participate with someone they know>

Participants will be compensated \$250, for full participation, receiving a MasterCard with this amount at the end of the test session.

Do you have any questions yet?

If you are interested in possibly participating, I need to go over some screening questions to see if you meet all the eligibility requirements of this study. Any information given to us will be kept secure and confidential.

Do I have your consent to ask the screening questions? [If yes, continue with the questions. If no, then thank him/her for their time and end the phone call.]

Participant Eligibility Questions:

- | |
|--|
| 1. What is your current age? _____ YOB _____
<i>Are you willing to show identification at the time of participation in order to verify your age?</i>
YES ____ NO _____ |
|--|

Criterion: Must be 18 - 80 years of age to participate. Must be willing to show an ID at the time of participation in order to verify their age. A driver's license or some other photo ID is acceptable.

2. Are you a U.S. Citizen? YES ____ NO ____
If No, are you a permanent resident with a valid green card to work anywhere in the U.S.?
YES ____ NO ____
To clarify, Are you a Visa holder or do you have a *Valid Green Card with permanent resident status*? Visa ____ Green Card ____
If you have a Visa you will not be eligible to participate. Those with a Permanent Resident Green Card are eligible.
Notes: _____

Criterion: Must be a U.S. citizen or permanent resident (green card holder able to work anywhere in the U.S. with NO restrictions such as limit on number of hours he or she can work each week or place he or she is allowed to work, for example, he or she can't be limited to only working at 1 company or VT only). Visa holders are not applicable.

3. If selected to participate in this study, you will be asked to provide your SSN number. Will you complete a W-9 for payment purposes as required by Virginia Tech at the time of participation? (*for payment documentation and tax recording purposes Virginia Tech will require them to complete a W-9*)
YES ____ NO ____

Please note: VA Tech would never require your SS # or any personal banking information during a phone call. If scheduled to participate in any type of study, VT would send instructions whether you need to bring personal information for an appointment, in order to complete required paperwork at a study location.

Must be willing to provide SSN number for payment purposes.

4. Are you available to come in for one day-long session, about 7 hours, during standard business hours (M-F, 8-5)? YES ____ NO ____
Comments, if any & Availability: _____

Preference for those available for a daytime session during standard business hours (M-F, 8 am to 5 pm). Note availability: some weekend appointments may occur.

5. You will be asked to sit at the side of a controlled, simulated intersection environment for two testing sessions, each lasting about 2.5 hours. One session in the morning, the other after a lunch break. (Keep in mind, there will be multiple breaks and you may ask for a break at any time during the experiment).

Would this present a problem for you? YES ____ NO ____

Criterion: Sitting for both sessions must not present a problem.

6. You will be asked to wear a sleeping mask, to cover your eyes, during the experimental testing. The mask provided will be new; each participant will have their own. Keep in mind, there will be multiple breaks and you may ask for a break at any time during the experiment. Would wearing a mask during the experiment present a problem for you? YES ____ NO ____

Notes: _____

Criterion: Must be comfortable with wearing a sleeping mask during the experimental portions of the study.

(2 sessions, each lasting about 2.5 hours each)

<Possible questions w/answers: They will be provided their own mask (new) and they may keep it. Those with eyewear will be asked to remove glasses prior to putting on the mask. They'll be encouraged to bring an eyeglass case with them.>

We need to ask a few questions about your medical history...

Do you have a history of any of the following medical conditions? If yes, please explain.

7. Do you have any mobility limitations which may cause you to require assistance getting in and out of a motor vehicle or walking to and from the building and out to the research location? YES _____ NO _____

Criterion: Must not require assistance to walk out to a vehicle or getting in and out of a motor vehicle – no mobility limitations. No leg braces, ankle/foot in a boot, etc. Must not require a wheel chair or mobility scooter.

8. Any Head Injury, Stroke, or illness or disease affecting the Brain? YES _____ NO _____
If yes, please explain: _____

Cannot have a history of brain damage from stroke, tumor, head injury, recent concussion, or disease or infection of the brain.

9. Current respiratory disorder/disease or any condition which requires oxygen? YES _____ NO _____
Notes: _____

Cannot have current respiratory disorder/disease or disorder/disease requiring oxygen.

10. Do you currently have any sleep disorders? (e.g. narcolepsy, sleep apnea, insomnia, etc.)
YES _____ NO _____

Criterion: Must not self-report, or be diagnosed with a CURRENT history of any sleep disorder. Must not currently use a CPAP machine or have been diagnosed they currently need to use a CPAP machine. If self-report they had a past history, but with lifestyle change or a change in health they are no longer currently suffering from the condition, then they may be eligible.

11. Any epileptic seizures or lapses of consciousness within the past twelve months?

YES _____ NO _____ Notes: _____

Cannot have had epileptic seizures or lapses of consciousness within the last 12 months.

12. Do you have uncontrolled diabetes? YES _____ NO _____

If yes, please explain: _____

Cannot have uncontrolled diabetes (frequent low/high blood sugar levels that they are struggling to keep regulated). Cannot have they been recently diagnosed or have been hospitalized for this condition, or incurred any changes in their insulin prescription during the past 3 months.

13. For research purposes, do you identify as Male, Female, [pause] or other? (Circle one)
If answer "Other", ask, "what are your personal pronouns"? _____

Criterion: Males and females will be recruited.

14. (Females only) Are you currently pregnant? (if "yes," politely inform the participant: while being pregnant does not disqualify you from participating in this study, you are encouraged to talk to your physician about your participation to make sure that you both feel it is safe. If you like, **we can send you a copy of the consent form to discuss with your physician.** Answer any questions)

YES _____ NO _____

(Can still participate, but encourage them to speak with their doctor first)

15. Do you have normal, or corrected to normal, vision? YES _____ NO _____

Criterion: Must have normal or corrected to normal vision in at least one eye.

16. Do you have normal, or corrected to normal, hearing in both ears? YES _____ NO _____

Criterion: Must have normal or corrected to normal hearing in both ears.

17. Are you comfortable reading, writing, and speaking English? YES _____ NO _____

Criterion: Must be able to read, write, and speak English comfortably. If the screener finds during the phone interview, the caller is struggling with their ability to communicate fluently in English, then the screener should avoid scheduling this person.

How did you hear about this project? _____

Recruiting Others:

Do you know anyone else with that may be interested in hearing about this study?

If yes, may we send you the information so you can forward it to them? (Or they can provide our phone #, email, website address to others; we will be happy to speak to anyone interested in hearing more) *We do ask that you do not participate on the same day as someone you know.*

Do you prefer we send you the info by Email: _____ or USPS mail (address): _____

If Eligible:

Availability: _____

Scheduled on (date & time): _____

Name: _____

Home Phone #: _____ Cell# _____ Work # _____

We encourage you to read a copy of the Informed Consent prior to coming in for your scheduled appointment. Please review it ahead of time and contact us with any questions or concerns. You will be asked to read & sign a copy of this document upon arrival at VTTI prior to participating. Do not bring this document with you to the appointment; we simply ask for you to review the

document ahead of time and to let us know you received it. Do you prefer we send as an email attachment or by USPS?

E-mail or mailing address: _____

Town or city they live & approximate travel time to VTTI:

Do you have any special dietary needs we should know about, such as gluten free, vegetarian, etc.?

Any Food allergies we should be aware of? _____

Would you like to be contacted for future studies? Yes: _____ No: _____

If yes, collect the following:

Last Name: _____ First Name: _____ Y.O.B. _____

Home Phone #: _____ Cell# _____ Work # _____

Town or city: _____ State: _____ Zip: _____

Specialty Driver's License _____

if CDL, endorsements: _____

restrictions: _____

Make and Model of Primary Vehicle (light) _____

APPENDIX B. INFORMED CONSENT FORM

VIRGINIA POLYTECHNIC INSTITUTE AND STATE UNIVERSITY *Informed Consent for Participants in Research Involving Human Subjects*

Title of Project: Electric Vehicle Detectability: Impact of Artificial Noise on Ability of Pedestrians to Safely Detect Approaching Electric Vehicles

Investigators: Luke Neurauter and Michael Roan

I. THE PURPOSE OF THIS RESEARCH PROJECT

This research study will investigate how easy it is for pedestrians to hear approaching vehicles. This is especially important when a pedestrian is deciding whether or not to cross at an intersection. Hybrid vehicles and electric vehicles (EVs) are quieter than standard vehicles and are increasing in popularity. This has caused concerns since they may be more difficult for pedestrians to hear as they approach. Some manufacturers have addressed this by adding artificial noise. This research project will examine how these added sounds impact safety during crossing situations. The results of this study will help identify characteristics that help pedestrians to hear the vehicles approaching. This in turn may impact federal requirements associated with these artificial sounds.

II. PROCEDURES

During your time here you will be asked to perform the following tasks.

1. Review the Informed Consent form. Ask any questions you may have, sign the Informed Consent Forms with the experimenter if you agree to participate.
2. Complete a hearing assessment.
3. Complete a Virginia Tech W9 tax form. This is required by Virginia Tech in order to process payment.
4. Listen to a brief overview of the study and the day's schedule.
5. Complete a pre-drive questionnaire
6. Participate in two test sessions with three other participants on the Virginia Smart Road, a closed test track. These test sessions will include one in the morning and one in the afternoon, with lunch provided in-between.
7. Each session involves remaining seated by the roadside while vehicles approach, one at a time, at slow speeds. You will be asked to identify when you detect the approaching vehicle, and when you no longer perceive it as a 'threat', in the sense that you are a crossing pedestrian and the vehicle has cleared the intersection. You will be given a button to press when you first hear the vehicle approaching. You will stop pressing the button when you feel it would be safe to cross the road.
8. You will be asked to wear an eye mask while you are seated during both of the sessions.
9. Follow instructions provided by experimenters assisting with the test sessions.
10. Complete a post-drive questionnaire

It is important that you understand we are not evaluating you in any way. We are collecting information about how artificial noise can impact perceptibility of approaching EVs by pedestrians. Any tasks you perform will contribute to the design and assessment of artificial noise configurations. Therefore, we ask that you perform to the best of your abilities. This experiment is expected to last approximately 7 hours.

III. RISKS

As a participant, you may be exposed to the following risks or discomforts by volunteering for this research:

1. The risks involved are similar to those one would experience while sitting adjacent to a lane of traffic with a vehicle passing at slow moving speeds.
2. Possible fatigue due to the length of the experimental sessions.
3. Possible discomfort wearing an eye mask throughout the road session.
4. The risk of injury during transport to or within the test site.
5. The risk associated with events such as equipment failure, wild animals entering the road, and weather changes. If at any point in the session the experimenter believes that continuing the session would endanger you or the equipment, he/she will stop the testing.
6. If you are pregnant you should talk to your physician and discuss this consent form with them before making a decision about participation.

The following precautions will be taken to ensure minimal risk to you:

1. An experimenter will monitor you and the approaching vehicles at all times.
2. Study area will be clutter free to the extent possible, and an experimenter will be available to assist at any time.
3. You will be encouraged to take breaks if so desired. Water will be available.
4. The experiment will run only during clear weather and low wind
5. You may decide not to participate or to cease participation at any time without penalty.
6. In the event of a medical emergency, or at your request, the experimenter will arrange medical transportation to a nearby hospital emergency room. You are allowed to elect to undergo examination by medical personnel in the emergency room. The experimenter has a cell phone in case of an emergency.
7. Vehicle speeds will be limited to under 15 mph
8. The study takes place on a closed test track. Although other vehicles may be on the road, at no time will they enter or drive near the testing area.
9. Due to the length of the individual sessions, a chair is provided for seating throughout. At no point will you be asked to cross the path of the approaching vehicles.
10. A first-aid kit will be available at the study site or in the experiment vehicles.
11. Although video recording will be made during the study, cameras are only recording the approaching vehicles. There will be no video collected of participants during this study.

Participants in a study are considered volunteers, regardless of whether they receive payment for their participation; under Commonwealth of Virginia law, workers compensation does not apply to volunteers; therefore, if not in an automobile, the participants are responsible for their own medical insurance for bodily injury. Appropriate health insurance is strongly recommended to cover these types of expenses. For example, if you were injured outside of an automobile during the project, the cost of transportation to the hospital emergency room would be covered by your insurance.

In the event of an accident or injury in an automobile (during transport to and from the test site), the automobile liability coverage for property damage and personal injury is provided. The total policy amount per occurrence is \$2,000,000. This coverage (unless the other party was at fault,

which would mean all expenses would go to the insurer of the other party's vehicle) would apply in case of an accident for all volunteers and would cover medical expenses up to the policy limit. For example, if you were injured in an automobile owned or leased by Virginia Tech, the cost of transportation to the hospital emergency room would be covered by this policy.

IV. BENEFITS

While there are no direct benefits to you from this research, you may find the experiment interesting. No promise or guarantee of benefits is made to encourage you to participate. Participation in this study will contribute to the improvement of pedestrian perceptibility of approaching electric vehicles and ultimately safety of vision-impaired pedestrians.

V. EXTENT OF ANONYMITY AND CONFIDENTIALITY

Data gathered in this experiment will be treated with confidentiality. Shortly after participation, your name will be separated from your data. A coding scheme will be employed to identify the data by participant number only (e.g., Participant No. 1). You may elect to have your data withdrawn from the study if you so desire, but you must inform the experimenters immediately of this decision so that the data may be promptly removed. It is possible that the Institutional Review Board (IRB) may view this study's collected data for auditing purposes. The IRB is responsible for the oversight of the protection of human subjects involved in research.

All data will be encrypted at the time of data collection and will be decrypted only for approved analyses.

VI. COMPENSATION

You will be compensated \$250 for complete participation. If you choose to withdraw before completing the study or if the study is terminated early, you will be compensated for the portion of time of the study for which you participated at the rate of \$30 per hour. All payments, whether for the full amount of \$250 or any partial amount, will be issued using a pre-loaded MasterCard. Please allow up to 1 full business day for activation of the card. Once activated, this card cannot be used past its expiration date. The issuing bank will also begin deducting a monthly service fee of \$4.50 after three months of inactivity.

If these payments are in excess of \$600 dollars in any one calendar year, then by law, Virginia Tech is required to file Form 1099 with the IRS. For any amount less than \$600, it is up to you as the participant to report any additional income as Virginia Tech will not file Form 1099 with the IRS.

VII. FREEDOM TO WITHDRAW

As a participant in this research, you are free to withdraw at any time without penalty. If you choose to withdraw, you will be compensated for the portion of time of the study for which you participated. Furthermore, you are free not to answer any question or respond to experimental situations without penalty. If you choose to withdraw, please inform the experimenter of this decision and he/she will provide you with transportation back to the building.

VIII. APPROVAL OF RESEARCH

Before data can be collected, this research must be approved, as required, by the Institutional Review Board for Research Involving Human Subjects at Virginia Tech and by the Virginia

Tech Transportation Institute. You should know that this approval has been obtained. This form is valid for the period listed at the bottom of the page.

IX. PARTICIPANT'S RESPONSIBILITIES

If you voluntarily agree to participate in this study, you will have the following responsibilities:

1. To follow the experimental procedures as well as you can.
2. To inform the experimenter if you have difficulties of any type.
3. To abstain from any substances that will impair your ability to participate.

X. PARTICIPANT'S PERMISSION AND ACKNOWLEDGMENTS

Check all that apply:

- I am not under the influence of any substances or taking any medications that may impair my ability to participate safely in this experiment.
- I am in good health and not aware of any health conditions that would increase my risk including, but not limited to lingering effects of a heart condition.
- I have informed the experimenter of any concerns/questions I have about this study.
- If I am pregnant, I acknowledge that I have either discussed my participation with my physician, or that I accept any additional risks due to pregnancy.

XI. QUESTIONS OR CONCERNS

Should you have any questions about this study, you may contact the Principal Investigator:

Luke Neurauter lneurauter@vtti.vt.edu 540-231-1522

Should you have any questions or concerns about the study's conduct or your rights as a research subject, or need to report a research-related injury or event, you may contact the Virginia Tech Institutional Review Board at irb@vt.edu or (540) 231-3732.

XII. Subject's Permission

I have read and understand the Informed Consent and conditions of this project. I have had all my questions answered. I hereby acknowledge the above and give my voluntary consent for participation in this project.

If I participate, I may withdraw at any time without penalty. I agree to abide by the rules of this project.

Participant Signature

Date

Experimenter Signature

Date

APPENDIX C. PRE-DRIVE QUESTIONNAIRE

Pre-Drive Questionnaire

1. On average, how many days per week do you cross the street?
 - a. Never
 - b. 1-2 days
 - c. 3-4 days
 - d. 5-6 days
 - e. Daily (7 days per week)

2. On average, how many days per week do you cross the street in an urban environment?
 - a. Never
 - b. 1-2 days
 - c. 3-4 days
 - d. 5-6 days
 - e. Daily (7 days per week)

3. On average, how many days per week do you cross the street in a rural environment?
 - a. Never
 - b. 1-2 days
 - c. 3-4 days
 - d. 5-6 days
 - e. Daily (7 days per week)

APPENDIX D. HEARING FORM

Hearing Measurement

1. Hearing Test:

Right Ear

- 1 KHz: _____
- 500 Hz: _____
- 1 KHz: _____
- 2 KHz: _____
- 3 KHz: _____
- 4 KHz: _____
- 6 KHz: _____
- 8 KHz: _____

Left Ear

- 1 KHz: _____
- 500 Hz: _____
- 1 KHz: _____
- 2 KHz: _____
- 3 KHz: _____
- 4 KHz: _____
- 6 KHz: _____
- 8 KHz: _____

Hearing Test

[seat participant and orient them as necessary – remember with the varying levels of vision-impairment, the testing device should always be out of their sight]

Next we are going to be performing an informal hearing test. This test will take no more than ten minutes, and I ask that you please stay as still and as quiet as possible so that your hearing through the headphones is not affected.

You will hear a series of three tones at several different sound levels. Here is the handheld button that you will be using for this test. [give participant device, help them locate button on top] You can hold the button in either hand, whichever is the most comfortable for you. As soon as you hear the sound, press the button firmly and release, do not hold the button down. Go ahead and depress the button a couple of times to get a feel for it.

Please do not guess, as this will cause the test to stop, and we will have to re-start the test from the beginning. I will let you know when the test is over, and I will then remove the headphones.

So that the headphones are positioned properly, I am going to place them on your ears from the back of your head. After I do so, please adjust them so that each earpiece is directly over your ear canal and there is no open space between.

Before I fit the headphones to your head, do you have any questions? Please remove your _____ (glasses, earrings, hair clips, rubber bands, hat, etc.) so that they don't get in the way of the headset.

[make sure to move silently around while testing so the motion-sensor lights do not turn off during testing!]

[when finished, tell the participant testing is complete and they can remove the headphones]

- **Ensure that the speaker in each headphone is placed directly over the ear canal and adjust the headband if needed.**
- 1. **Turn the audiometer.**
- 2. **To start the test, press the button labeled AUTO. To pause, press the MAN button and resume the test by pressing the AUTO button again.**
- 3. **The test consists of sounds played at 1 KHz, 500 Hz, 1 KHz (repeated for accuracy), 2 KHz, 3 KHz, 4 KHz, 6 KHz, and 8 KHz. Each frequency level is given in a series of three tones, and the decibel level of the following three tones is either increased or decreased based on the participant's response. A series of sounds is played to the right ear first, and then played to the left ear.**
- 4. **If the participant pushes the button when there is not a tone ("false positive"), the audiometer will beep and display FALSE RESPONSES. In this case, the experimenter should explain that the participant should not guess. Then, the experimenter should begin the test again.**
- 5. **When the test is completed, TEST COMPLETE will be displayed and an audible beep will be presented.**

APPENDIX E. HEARING TEST RESULTS

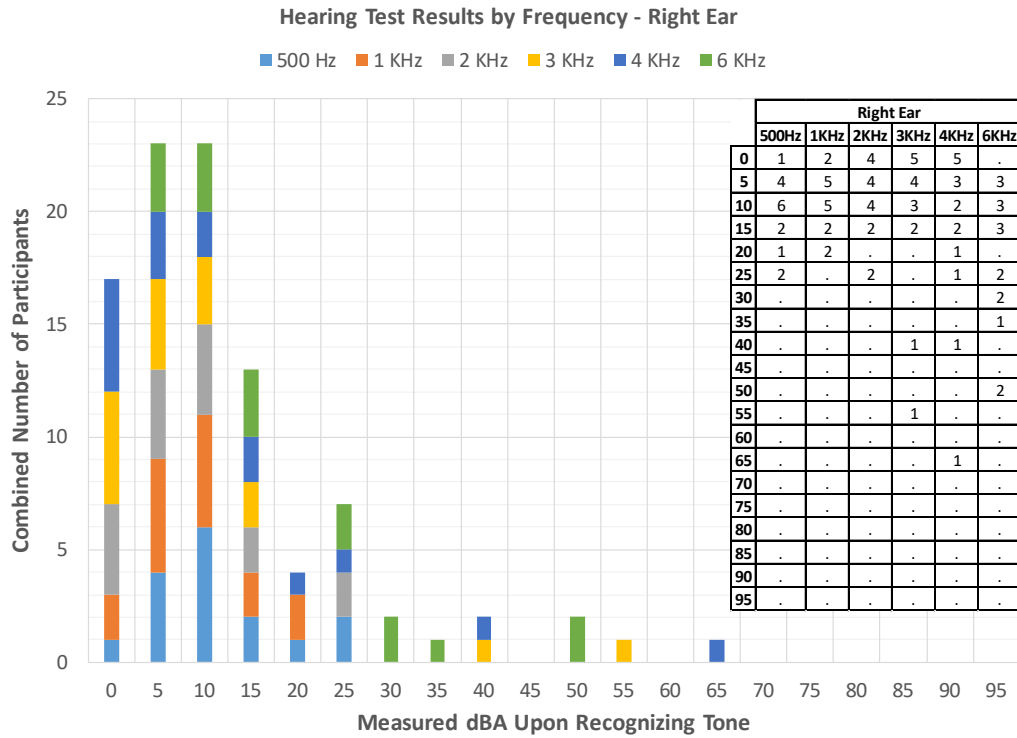
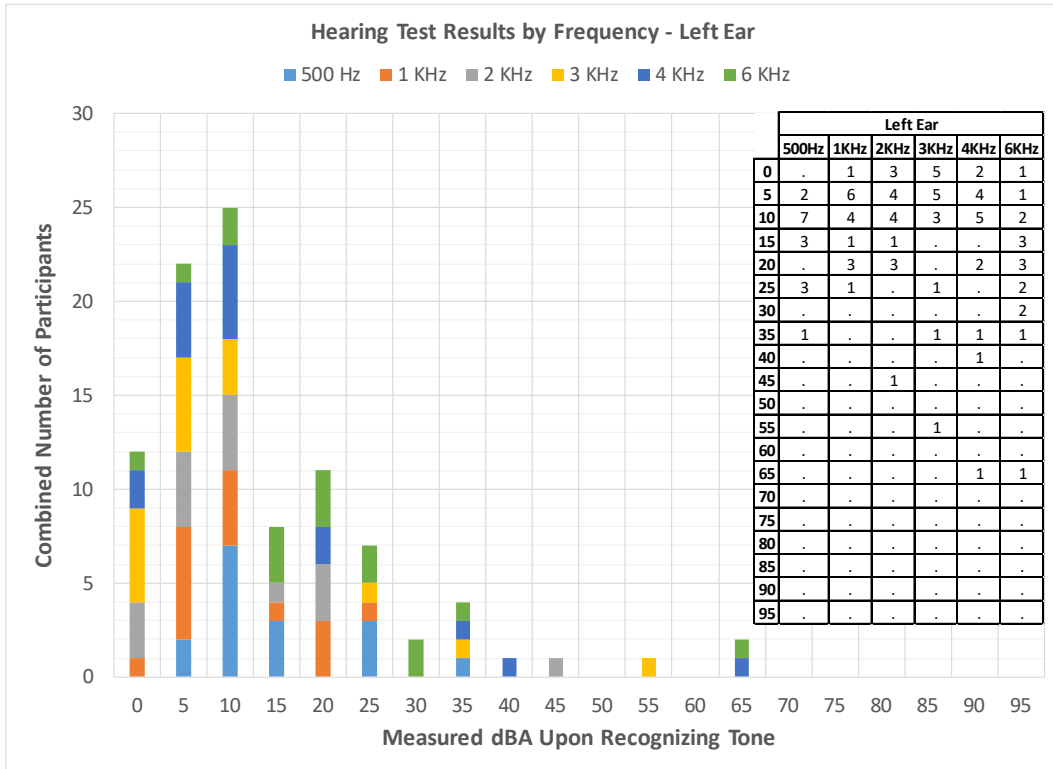

Recorded dBA Required for Participant to Detect Sounds Issued at Given Frequency during Hearing Examination - Left Ear

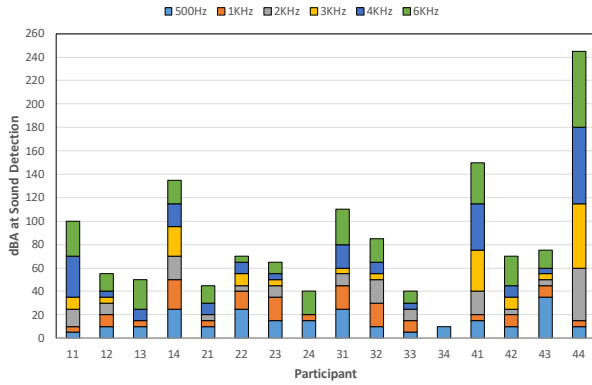

Recorded dBA Required for Participant to Detect Sounds Issued at Given Frequency during Hearing Examination - Right Ear

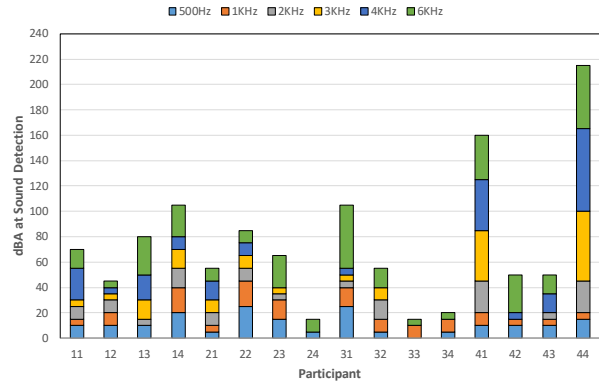

Cumulative Recorded dBA Required for Participant to Detect Sounds Issued at Given Frequency during Hearing Examination

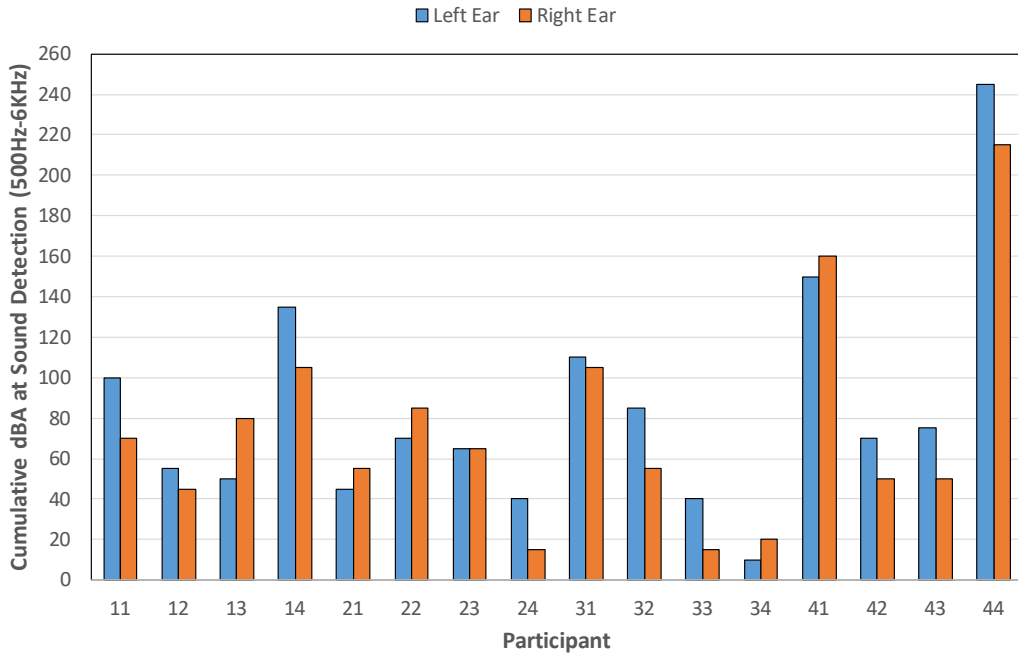

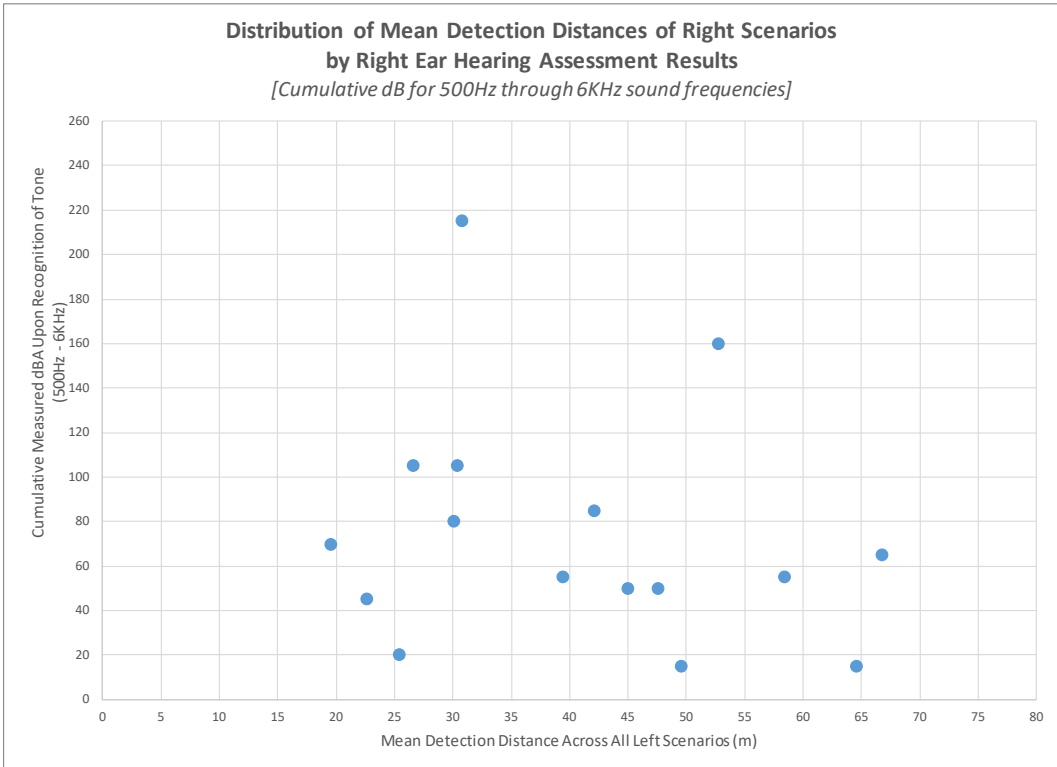
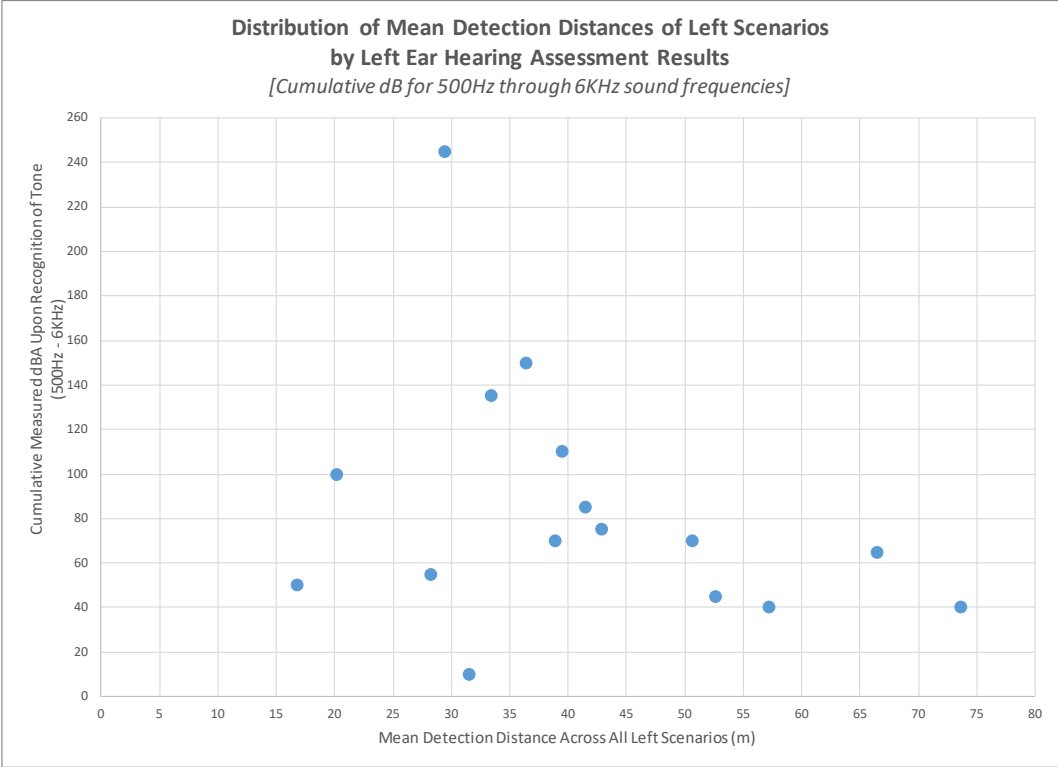

APPENDIX F. INITIAL OVERVIEW PROVIDED TO PARTICIPANTS

Preparation

- 1) **Get the correct participant packets and double check the packet contents:**
 - a. Informed Consent form (2 copies)
 - b. Hearing Form
 - c. W-9 Tax form
 - d. Pre-Drive Questionnaire
 - e. Post-Drive Questionnaire (1 copy per session)
 - f. Check that all forms (except Informed Consent forms) are labeled with the participant's number. Label Post-Drive Questionnaire until participants are seated in the testing area.

- 2) **Set up the subject prep rooms (Interchange A and Cloverleaf Conference Rooms, or other):**
 - a. Print experimental Protocol/Script
 - b. Make sure you have extra pens
 - c. Check the schedule: verify participant arrival time & that they are not cancelled
 - d. Check to see if the conference rooms are ready (and that no one else is in there using the room)
 - e. Turn on overhead lights
 - f. Make sure all aids needed to administer the hearing tests are in the Cloverleaf Conference Room
 - g. Post sign on the door of Interchange A and Cloverleaf Conference Rooms, "Do Not Disturb" and shut the door

Participant Arrival

- 3) **Wait for the participants:**
 - a. Some participants come in early, please be in the lobby of B1 at least 10 minutes before scheduled time
 - b. Check the phone(s) for messages before going to B1 lobby
 - c. Be flexible: as participants arrive, take them into Interchange A (or other scheduled), greet, and administer informed consent (one at a time, or in groups)
 - d. If all participants have not shown up after 10-15 minutes
 - i. Check the front desk phone &/or Christine's phone (1-1532) for messages
 - ii. Call remaining participants

- 4) **Greet Participant:**
 - a. Note time of arrival

 - b. Introduction:
[Introduce Yourself] *Thank you for coming out today. We're going to start off by going through the informed consent form which gives you an overview of what you'll be doing throughout this experiment, what we're studying, the potential risks*

involved, your responsibilities as a participant, your compensation, and so forth. I would also like to point out, as stated in this form, that you are free to withdraw from the study at any point without any penalty whatsoever.

There are two copies of the forms, one for my records and one for yours, and your signature is required on both at the end of the document if you would like to participate in the study, on both copies.

c. Informed Consent:

[Ask participant to check Section X and sign both copies.]

[As experimenter, sign and date both copies of the IC. Give participant their copy.]

Should a participant choose not to continue, proceed to Step 6.

Now we will be administering hearing tests so in order to do that, [] will be taking you each individually into another room. For those of you left in the room, I will have you fill out some additional paperwork here.

[Other experimenter will take 1st participant into Cloverleaf Conference Room]

[Administer W-9, pre-drive questionnaire to others in room]

5) Lunch orders, Hearing Tests, W-9, and Pre-Drive Questionnaire:

a. Take Lunch orders

b. Hearing Test:

[Read hearing test protocol]

[Guide participant back to Interchange A and get next participant.]

c. W-9:

Next, I'm going to have you fill out a W-9. This form is required by Virginia Tech policy to process payment for your participation today.

d. Administer Pre-Drive Questionnaire:

Next, I will have you fill out the Pre-Drive Questionnaire.

6) Pay participant the minimum, \$30, if they are not continuing with the study.

Refer to Clincard protocol

7) Overview of the Study and Day's Schedule:

[Once all participants are back in Interchange A]

Next we will briefly go over the study that you all will be participating in today and the day's schedule.

a. Study Overview:

As explained in the Informed Consent Form, this research study is investigating how detectable approaching vehicles are from the perspective of a pedestrian who is trying to cross the street; the primary interest is detectability of electric vehicles. As such, we have included a handful of sound conditions in order to assess differences in detectability. We have created a simulated intersection on the Virginia Smart Road, a closed test-track located here at VTTI. You will be positioned on one side of this

simulated intersection, representing pedestrians who are ready to cross from one side of the intersection to the other. However, you will not actually be asked to cross the intersection; instead, you will be seated alongside the travel lane, surrounded by speakers which will emit white noise. This noise is intended to simulate background noise at a level typically found within an intersection environment.

During today's session, the research vehicle will approach the intersection, from both directions, at varying slow speeds. As each vehicle approaches, you will be asked to identify the point at which you detect the approaching vehicle by pressing a handheld button. You should then continue pressing the button until the approaching vehicle has passed and is no longer a 'threat' and you think it would be safe to cross the road. During their approach, the vehicle may either continue past at a constant speed, or come to a stop close to where you are seated. For when to release the button, we'd like you to adhere to the following:

- *For cases where the vehicle continues without stopping: release the button at the time the vehicle has driven past your location, as it is no longer a threat and therefore safe to cross*
- *For cases where the vehicle comes to a complete stop: in this context, please assume that coming to a stop indicates it is safe to cross – either the vehicle is yielding and allowing you to cross, they have a red light, etc.*

We will allow you to practice this across a handful of practice trials. If, at anytime, you feel you have pressed the button by mistake, please release and then press down again when you believe a vehicle is approaching. Do any of you have questions about this at the moment?

During the test sessions, we ask that no verbal feedback, such as talking, be made, in order not to influence other participants' auditory detection of the approaching vehicle. We also ask that you not discuss the study, particularly your perceptions of the approaching vehicle, etc. until after we have completed all on-road testing and questionnaires.

Do you have any questions about the study you will be participating in today?

b. Schedule:

After we complete the upfront material this morning, we will be transporting you all as a group down to the Smart Road in our research vehicle with trained experimenters who are employees from VTTI. We will make sure you are set up and comfortable in our simulated intersection environment prior to beginning the experiment, but there will be multiple researchers on the road with you all at all times

during the study. Because we have many trials to run today, we will be splitting the experiment into two sessions, one which we will run this morning and one in the afternoon, with lunch provided in-between. During the test sessions, we will be providing snacks and refreshments, and you can request breaks as needed.

In order to minimize how often we need to leave the road, this is a good opportunity to use the facilities before we head down.

Do you have any questions about our schedule today?

[escort any participants to the restrooms, as necessary, and once all have returned and you have confirmed the team is ready to head to the road, escort participants outside to the B1 lobby and to the vehicle]

8) Guide participants to vehicle

9) On-Road Test

- a. Refer to On-Road Protocol

10) Post-Drive Questionnaire, Payment

- a. Administer Post-Drive Questionnaire

Before concluding your participation we'd like to capture your perceptions of the vehicle sounds you experienced during today's on-road testing. We will play each sound separately, allowing you to answer all questions before moving to the next sound. The first group of questions all use the same 7-point rating scale, with 1 being 'strongly disagree', 4 'neutral', and 7 'strongly agree'. Please avoid reacting to the sounds while answering questions so as not to bias other participants. Each of you should have four copies of the survey. Please use one copy for each sound. This one-page survey consists of seven questions. Please review the questions now before we play the first sound. Any questions before we start?

For the order of sound to be played, refer to the last page of task order sheet. Play each sound on the laptop for 30 seconds

- b. Pay \$250 for complete participation

11) Thank participants and guide them to leave the building

APPENDIX G. TEST SITE OVERVIEW PROVIDED TO PARTICIPANTS

On-Road Protocol

1. Orient Participants to Testing Environment

- a. Once van has stopped:

As you can see, we have arrived at the testing location on the Virginia Smart Road. Before we exit the van and begin the experiment I am going to provide an overview of the testing environment. Let me know if you have any questions during this overview.

This portion of the Smart Road is a two-lane road, and the testing area where you will be seated is in the right lane. There are 4 large barber chairs, lined up in two banks of two in a staggered position. As they are closely positioned in order to minimize the variance of the ambient sound we are introducing to the environment, please do not move them as you get in and out of the chairs.

Your seated positions are surrounded by 5 speakers, forming a semi-circle, to accomplish the ambient background noise we are adding to the environment. There will be a microphone with a stand positioned to the rear of each chair and the mic directly overhead each of the chairs (will be above your heads). These microphones allow us to capture the sound levels from your exact position when you press and release the button. There are numerous wires running to the speakers and other testing equipment. Please watch your step when entering/leaving the testing area.

Note that the ambient noise levels may change periodically, and there may also be times during which there is no sound emitted from the speakers. During these times, we ask that you continue to remain quiet unless a researcher addresses the group otherwise, as this does not mean testing has stopped or that we have finished the session.

Do you have any questions regarding the testing environment?

Answer any questions.

Alright if you're ready we will exit the van, and have everyone get seated.

Open van door and have participants seated.

Introduce other team members.

2. Orient Participants to Study Procedure

- a. Once participants seated and given sleeping masks and buttons:

Now that you are seated I'm going to walk you through the actual procedure and what we are asking of each of you. A research vehicle will approach in the lane adjacent to us, from both directions, at varying slow speeds. As the vehicle approaches, you will be asked to identify the point at which you detect the approaching vehicle by pressing a handheld button. Throughout the test, you will also be asked to wear an eye mask to eliminate any advantages by vision as we are strictly evaluating auditory solutions.

So, using the handheld button, as soon as you detect an approaching vehicle I'd like you to press this button. Feel free to go ahead press it a few times. Once you have detected an approaching vehicle and pressed the button, we would like you to continue pressing the button until the approaching vehicle is no longer a 'threat' and you think it would be safe to cross the road. During their approach, vehicles may either continue past at a constant speed, or come to a stop close to where you are seated. For releasing the button, we'd like you to adhere to the following:

- *For cases where the vehicle continues without stopping: release the button at the time the vehicle has passed your location, as it is no longer a threat and therefore safe to cross*
- *For cases where the vehicle comes to a complete stop: in this context, please assume that coming to a stop indicates it is safe to cross – either the vehicle is yielding and allowing you to cross, they have a red light, etc.*

If, at any time, you feel you have pressed the button by mistake, please release and then press down again when you believe a vehicle is approaching. In a moment, we will give you the opportunity to practice pressing the button as the vehicle approach. After these practice runs, there will be an opportunity for you to ask any further questions should you have them. We will let you know when the practice component has finished, and the actual trials will begin; however, during both the practice and actual trials, remember that we are asking you to remain quiet and raise your hand if you have any questions or needs to be addressed.

Note that vehicles will be making U-turns following each run.

Again, during the test sessions, we ask that no verbal feedback, such as talking, be made, in order not to interfere with the detection of the oncoming vehicles by other participants. Accordingly, should you need to get the attention of a researcher (e.g. want to ask a question, take a break, get a drink/snack, alert experimenter that an external noise is interfering with ability to perceive vehicle, etc.) please raise your hand and a researcher will pause testing and address your question accordingly.

We also ask that you not discuss the study, particularly your perceptions of the approaching vehicle, etc. until after we have completed all on-road testing and questionnaires.

At this time, I would also ask that you please turn off or silence your cell phones. Do you have any questions?

If you're ready, please put on the sleeping mask that we provided to you and we will start the experimental session.

[Button press check on SolEye one participant after another]

[After practice runs, address any questions. Reiterate button press/release times.]
Now we are ready to begin the actual trials. This session will last the next couple of hours, so there will be a scheduled break at the halfway point, at which time we will allow everyone to stand, stretch their legs, have a snack/drink, etc. However, we would like to be respectful of everyone's time, and we will try to limit this break to approximately 5 minutes.
Is everyone ready? We will now begin the test session.

APPENDIX H. POST-DRIVE QUESTIONNAIRE

Post-Drive Questionnaire

Before concluding your participation we'd like to capture your perceptions of the vehicle sounds you experienced during today's on-road testing. We will play each sound separately, allowing you to answer all questions before moving to the next sound. The first group of questions all use the same 7-point rating scale, with 1 being 'strongly disagree', 4 'neutral', and 7 'strongly agree'. Please avoid reacting to the sounds while answering questions so as not to bias other participants.

****Repeat for sounds 1-4**

1. This is an appropriate sound for electric vehicles.

1	2	3	4	5	6	7
Strongly Disagree			Neutral			Strongly Agree

2. This sound would make it easier for pedestrians to detect approaching electric vehicles, compared to no sound at all.

1	2	3	4	5	6	7
Strongly Disagree			Neutral			Strongly Agree

3. As a pedestrian, this sound effectively communicates that an electric vehicle is approaching.

1	2	3	4	5	6	7
Strongly Disagree			Neutral			Strongly Agree

4. This sound would increase pedestrian safety by increasing their awareness of approaching electric vehicles.

1	2	3	4	5	6	7
Strongly Disagree			Neutral			Strongly Agree

5. As a pedestrian, I would find it annoying if electric vehicles used this sound.

1	2	3	4	5	6	7
Strongly Disagree			Neutral			Strongly Agree

6. What do you like about this sound?

7. What do you dislike about this sound?

REFERENCES

1. National Highway Traffic Safety Administration (2017). *2016 Fatal Motor Vehicle Crashes: Overview*, NHTSA's National Center for Statistics and Analysis.
2. Cobb, J. (2017). "The World Just Bought Its Two-Millionth Plug-in Car." Retrieved October 24th, 2017, from <http://www.hybridcars.com/the-world-just-bought-its-two-millionth-plug-in-car/>.
3. General Motors (2017). "GM Outlines All-Electric Path to Zero Emissions." Retrieved October 24th, 2017, from <http://www.gm.com/mol/m-2017-oct-1002-electric.html>.
4. Neurauter, L., Roan, M., Song, M., Harwood, L., Britten, N., and Miller, M. (2016). *Electric Vehicle Detectability: Impact of Artificial Noise on Ability of Pedestrians to Safely Detect Approaching Electric Vehicles*. (Unpublished General Motors Report): Virginia Tech Transportation Institute.
5. Neurauter, M. L., Roan, M., Song, M., Harwood, L., Moore, D., and Glaser, D. (2017). *Electric Vehicle Detectability by the Vision Impaired: Quantifying Impact of Vehicle Generated Acoustic Signatures on Minimum Detection Distances*. Paper presented at the 25th International Technical Conference on the Enhanced Safety of Vehicles (ESV), Detroit, MI.
6. Roan, M., Neurauter, M.L., Moore, D., and Glaser, D. (2017). *Electric Vehicle Detectability: A Methods-Based Approach to Assess Artificial Noise Impact on the Ability of Pedestrians to Safely Detect Approaching Electric Vehicles*. SAE 2017 Noise and Vibration Conference and Exhibition, Grand Rapids, MI.
7. United Nations Economic Commission of Europe. (2015). *Proposal for a new regulation concerning the approval of quiet road transport vehicles (QRTV)* (ECE/TRANS/WP.29/GRB/2015/9). Retrieved from <http://www.unece.org/fileadmin/DAM/trans/doc/2015/wp29grb/ECE-TRANS-WP.29-GRB-2015-09e.pdf>
8. National Highway Traffic Safety Administration. (2018). *Minimum sound requirements for hybrid and electric vehicles*. Docket Number NHTSA-2018-0018. Washington, DC: U.S. Department of Transportation.
9. Parizet, E., Ellermeier, W., & Robart, R. (2014). *Auditory warnings for electric vehicles: Detectability in normal-vision and visually-impaired listeners*. *Applied Acoustics*, 86, 50-58.
10. National Highway Traffic Safety Administration. (2011). *Minimum sound requirements for hybrid and electric vehicles*. Docket Number NHTSA-2011-0148. Washington, DC: U.S. Department of Transportation.