

**Improved Quarry Design  
Using Deterministic and Probabilistic Techniques**

By

John C. Bullock

Thesis submitted to the Faculty of Virginia Polytechnic Institute and State University in  
partial fulfillment of the requirements for the degree of

Master of Science  
in Mining and Minerals Engineering

APPROVED

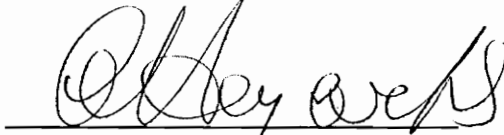

Christopher Haycocks, Committee Chairman



Gerald Luttrell

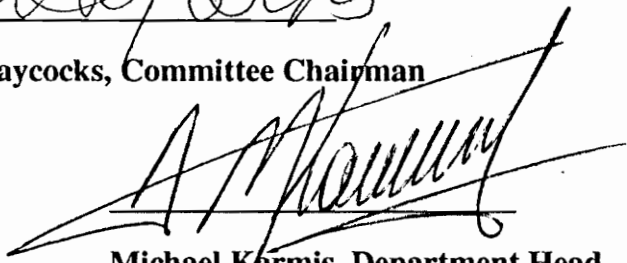

Michael Karmis, Department Head

September, 1993

Blacksburg, Virginia

C.2

LD  
5655  
V855  
1993  
3844  
C2

## **ABSTRACT**

Limestone and dolomite quarries were mapped to determine specific slope failure mechanisms for the various geological and structural conditions. Wedge failure and plane failure were determined to be the most influential mechanisms. Algorithms for analyzing these mechanisms were incorporated into the software package PSLOPE. The program is designed to facilitate progressive stability evaluation of quarry highwalls as mining continues and permits calculation of safety factors and probabilistic reliability. Safety factor evaluations with the potential for back-analysis and sensitivity studies are included to investigate alternative highwall designs. Reliability analysis using Monte Carlo sampling minimizes uncertainty and allows the use of all available data in a stability evaluation. Extensive "help" menus are incorporated into the program. The "help" menus include ranges of physical properties such as cohesion and friction angle for specific lithologic units determined from published research. This package includes an optimum design protocol that can be followed to avoid massive failure. The program was developed in conjunction with the quarry industry and is demonstrated through technical problem solving and a detailed case study. A large carbonate quarry in the eastern U.S. was studied in detail to demonstrate the utility of PSLOPE.

## **Acknowledgment**

I am indebted to Dr. Christopher Haycocks, my major advisor, for his support and guidance during this research at Virginia Tech. Completion of this thesis would not have been possible without his encouragement and patience. I would also like to thank the other members of my advisory committee, Dr. Michael Karmis and Dr. Gerald Luttrell for their support and constructive suggestions in this research. A special note of thanks is given to Richard Fraher for his assistance with the computer software necessary to complete this thesis and to Neil Haycocks for the many drawings within it.

This expression of appreciation would not be complete without the recognition of my wonderful mother and my lovely wife for their encouragement and support in this endeavor.

## TABLE OF CONTENTS

ABSTRACT .....	ii
ACKNOWLEDGMENT .....	iii
TABLE OF CONTENTS .....	iv
LIST OF FIGURES.....	vii
LIST OF TABLES .....	ix
LIST OF PLATES .....	x
CHAPTER I. - INTRODUCTION .....	1
1.1 Statement of Problem.....	1
1.2 Objectives/Approach.....	2
CHAPTER II. - LITERATURE REVIEW.....	3
2.1 Properties of Rock in the Stability of Slopes.....	3
2.1.1 Rock Mass.....	3
2.1.2 Discontinuities.....	4
2.1.3 Continuity.....	6
2.1.4 Spacing.....	7
2.1.5 Attitude.....	7
2.1.6 Dispersion .....	9
2.1.7 Fabric .....	10
2.1.8 Geologic Characteristics .....	10
2.1.9 Mineralization of Discontinuities.....	11
2.2 Hydrology.....	11
2.2.1 Precipitation .....	11
2.2.2 Infiltration .....	12
2.2.3 Groundwater Movement.....	13
2.2.4 Permeability.....	17
2.2.5 Effect of Gouge.....	17
2.2.6 Laboratory and Case Studies.....	20
2.3 Seismic Acceleration .....	21
2.3.1 Equivalent-static Load .....	21
2.3.2 Pseudo-static Load .....	23
2.4 Stability Criteria .....	23
2.4.1 Mohr-Coulomb Strength.....	24
2.4.2 Asperities .....	25
2.4.3 Water Pressure and Seismic Acceleration.....	27
2.4.4 Discontinuity Filling Material .....	28

2.5	Methods of Deterministic Analysis .....	30
2.5.1	Factor of Safety .....	30
2.5.2	Finite Element.....	31
2.6	Failure Modes .....	31
2.6.1	Plane Failure.....	32
2.6.2	Wedge Failure .....	36
2.6.3	Rotational Failure .....	41
2.6.4	Raveling Failure.....	43
2.6.5	Toppling Failure .....	43
2.7	Influence of Slope Curvature.....	46
2.8	Deterministic Stability .....	46
2.8.1	Operational Stability and Long-term Stability.....	46
2.8.2	Design Protocols .....	47
2.8.3	Magnitude of Failure.....	49
2.9	Reliability in Stability.....	51
2.9.1	Probabilistic Methods .....	51
2.9.2	Interpretation of Reliability .....	55
<b>CHAPTER III. - SOFTWARE DEVELOPMENT.....</b>		<b>57</b>
3.1	Identification of Failure Mechanisms .....	57
3.2	Development of PSLOPE.....	57
3.3	Hardware Requirements .....	59
3.4	Software Components.....	59
3.5	Using PSLOPE .....	60
3.6	Input of Geotechnical Data.....	60
3.7	Availability of 'Help' .....	64
3.8	Safety Factors from 'Plane Stability' and 'Wedge Stability'.....	74
3.9	Investigation to Determine Possibility of Failure in 'Wedge Stability'.....	74
3.10	'Reliability in Plane Stability' and 'Reliability in Wedge Stability'.....	77
3.11	Evaluation of Ultimate and Bench Slope Angles .....	80
3.12	Program Validation .....	80
3.13	Back-Analysis .....	87
3.14	Sensitivity Studies .....	87
<b>CHAPTER IV. - QUARRY STABILITY EVALUATION.....</b>		<b>91</b>
4.1	Introduction .....	91
4.2	Methodology of Evaluation.....	91
4.3	Quarry Description.....	92
4.4	Mine Plans .....	95
4.5	Geology.....	95
4.6	Hydrology.....	99
4.7	Identification of Structural Regions .....	101
4.8	Rock Mass Rating.....	101
4.9	Potential Failure Modes.....	109
4.10	Analysis of Plane and Wedge Failures.....	110

4.11 Reliability Evaluations .....	110
4.12 Analytical Assumptions .....	113
4.13 Flooded Pit Condition .....	114
4.14 Results of Analysis .....	116
4.15 Interpretation of Analysis .....	119
4.16 Conclusions of Quarry Stability Evaluation.....	130
<b>CHAPTER V. - CONCLUSIONS and RECOMMENDATIONS.....</b>	<b>133</b>
5.1 Conclusions.....	133
5.2 Recommendations .....	134
<b>REFERENCES .....</b>	<b>135</b>
<b>APPENDIX A - Listing of PSLOPE Program Code.....</b>	<b>140</b>
<b>VITA .....</b>	<b>176</b>

## LIST OF FIGURES

Figure 2.1 - Flow Lines and Equipotential Lines Within a Slope (Hoek and Bray, 1991) .....	18
Figure 2.2 - Triangular Distribution of Water Pressure in a Rock Slope (after Hoek and Bray, 1991) .....	29
Figure 2.3 - Plane Failure (after Afrouz, 1992).....	33
Figure 2.4 - Wedge Failure (after Afrouz, 1992).....	37
Figure 2.5 - Wedge Factor 'K' as a Function of Discontinuity Geometry (Hoek and Bray, 1991) .....	40
Figure 2.6 - Rotational Failure (after Afrouz, 1992).....	42
Figure 2.7 - Raveling Failure (after Haycocks et al., 1991).....	44
Figure 2.8 - Toppling Failure (after Afrouz, 1992).....	45
Figure 2.9 - Simplified Design Protocol for Highwall Stability (Haycocks et al., 1991).....	50
Figure 2.10 - Volume Produced By Failure of Differing Discontinuity Inclinations .....	53
Figure 3.1 - Simplified PSLOPE Flowchart.....	58
Figure 3.2 - Introductory Form of PSLOPE.....	61
Figure 3.3 - 'General Help' Screen.....	62
Figure 3.4 - Example of Error Checking by PSLOPE.....	63
Figure 3.5 - PSLOPE 'Editor' Screen .....	65
Figure 3.6 - Plane Stability Analysis Help Screen .....	66
Figure 3.7 - General Conditions of Plane Failure Screen.....	67
Figure 3.8 - Plane Stability Analysis Assumptions Screen.....	68
Figure 3.9 - Example of Friction Angle Help Screen .....	69
Figure 3.10 - Example of Cohesion Help Screen .....	70
Figure 3.11 - 'Wedge Stability' Help Screen .....	71
Figure 3.12 - General Conditions of Wedge Failure Screen .....	72
Figure 3.13 - Wedge Stability Analysis Help Screen.....	73
Figure 3.14 - 'Plane Stability' Screen Prior to Data Input.....	75
Figure 3.15 - Message Box Indicating Input Does Not Form Unstable Wedge .....	76
Figure 3.16 - Help on 'Reliability in Plane Stability' Screen.....	78
Figure 3.17 - Help on 'Reliability in Wedge Stability' Screen .....	79
Figure 3.18 - Ultimate Slope Angle Versus Bench Slope Angle.....	81
Figure 3.19 - Recalculation of Plane Stability Under Dry Condition .....	82
Figure 3.20 - Recalculation of Plane Stability Under Saturated Conditions .....	83
Figure 3.21 - Recalculation of Wedge Stability Under Dry Conditions .....	85
Figure 3.22 - Recalculation of Wedge Stability Under Saturated Conditions.....	86
Figure 3.23 - Graph Showing Results of Back-analysis .....	88
Figure 3.24 - Graph Showing Sensitivity of Slope Angle to Factor of Safety .....	90

Figure 4.1 - Map Showing Quarry Topography.....	93
Figure 4.2 - Geologic Cross-section of Quarry.....	96
Figure 4.3 - Drainage in Area of Quarry.....	100
Figure 4.4 - Location of Discontinuity Measurements in Quarry.....	102
Figure 4.5 - Stereographic Contours of Discontinuity Poles, Structural Region I.....	104
Figure 4.6 - Stereographic Contours of Discontinuity Poles, Structural Region II .....	105
Figure 4.7 - Projections of Mean Discontinuity Planes, Structural Region I.....	106
Figure 4.8 - Projections of Mean Discontinuity Planes, Structural Region II.....	107
Figure 4.9 - Design Areas Developed from Projected Mineable Limit.....	111
Figure 4.10 - Distribution of Hydraulic Forces Under Flooded Pit Conditions .....	115
Figure 4.11 - Wulff Equal Angle Projections - Design Area 1.....	117
Figure 4.12 - Reliability Graph, Design Area 1, Saturated Conditions, $c = 0$ .....	120
Figure 4.13 - Reliability Graph, Design Area 1, Flooded Pit Conditions, $c = 0$ .....	121
Figure 4.14 - Reliability Graph, Design Area 1, Saturated Conditions, $c = 4000$ psf .....	122
Figure 4.15 - Reliability Graph, Design Area 1, Flooded Pit Conditions, $c = 4000$ psf ..	123
Figure 4.16 - Reliability Graph, Design Area 1, Saturated Conditions, $c = 9000$ psf .....	124
Figure 4.17 - Reliability Graph, Design Area 1, Flooded Pit Conditions, $c = 9000$ psf ..	125
Figure 4.18 - Impact of Safety Factor on Reliability .....	128

## LIST OF TABLES

Table 2.1 - Rock Mass Rating (RMR) Classification (after Bieniawski, 1974) .....	5
Table 2.2 - Joint Property Classification System (after Stacey, 1968) .....	8
Table 2.3 - Coefficient of Permeability for Various Types of Rock (after Bedient, 1992) .....	19
Table 2.4 - Seismic Zones and Associated Damage (after U.S. Army, 1977) .....	22
Table 2.5 - Relative Significance of Reliability (after McCracken, 1983) .....	56
Table 3.1 - Input Data for Wedge Stability Recalculation (Hoek and Bray, 1991) .....	84
Table 4.1 - Summary of Discontinuity Measurements.....	103
Table 4.2 - Rock Mass Rating (RMR) of Quarry.....	108
Table 4.3 - Design Area Dip Azimuths.....	112
Table 4.4 - Critical Discontinuity Combinations for Design Areas .....	118
Table 4.5 - Reliability Tables for $c = 4000$ psf.....	126
Table 4.6 - Reliability Tables for $c = 9000$ psf.....	127
Table 4.7 - Design Recommendations for Long-term Slope Stability at 85% Reliability.....	132

## LIST OF PLATES

Plate 2.1 - Dissolution of Carbonate Rock .....	15
Plate 2.2 - Rock Slope Failure in Southern Virginia .....	16
Plate 2.3 - Plane Failure.....	34
Plate 2.4 - Wedge Failure .....	38
Plate 2.5 - Unstable Slope in Active Producing Area.....	48
Plate 4.1 - Quarry Evaluated for Stability.....	94

## CHAPTER I. - INTRODUCTION

### **1.1 Statement of Problem**

In 1992, in the United States, 1,600 companies operating 3,300 quarries in 48 states produced 1.16 billion tons of crushed stone. This 5.3% increase over 1991 has an estimated value of approximately \$5.6 billion and represents the sixth consecutive annual production exceeding one billion tons (Tepordei, 1993). However, in spite of the essential and increasing need for rock, environmental and social pressures are severely restricting the mining industries' ability to obtain permits to open new quarries. To meet the demand for lime, aggregate, and other non-metallics, mining companies are being forced to develop existing quarries to considerable depths, and wall stability is becoming a primary consideration. Slope failures of over 600 feet are now a matter of record in the eastern United States. These highwall failures may result in personnel accidents, damage to equipment, and disruption of production (Roberts and Hoek, 1971). Since slope failures in abandoned quarries can result in safety hazards, environmental damage, and property value reductions, stable ultimate slope design is now a fundamental part of the permitting and zoning requirements for development of many quarries (Greenland and Knowles, 1970 ; White, 1989).

Rock quarries may be subdivided into two broad types, aggregate and dimension stone. Typically, the materials mined are structurally strong and consist of hard rocks such as limestones, granites, and gneisses. In dimension stone quarries which produce rock for facing buildings, gravestones, and other ornamental uses, great care is taken not to fracture the rock during mining except along the desired plane. This and the inherent structural intactness of the materials selected for the dimension stone result in steep highwalls of up to 1,000 feet in height that are usually very stable (Hartman, 1987). Since

these quarries constitute only 1% to 2% of total surface mine production in the U.S., they are not particularly relevant and are not considered in this analysis. The more numerous conventional quarries which utilize bench blasting were evaluated.

## **1.2 Objectives/Approach**

Massive slope failures can only be successfully avoided if slope design is incorporated into the basic quarry highwall scheme. Most quarry companies have little experience in massive failures and are now urgently requesting help.

The objective of this research will be to determine mechanisms of highwall failure in conventional quarries and to develop a software program that evaluates those mechanisms. Criteria for the software will include compatibility with hardware available at the mine site and an abbreviated library of mining and rock mechanics research to assist the user in customization of the slope stability analysis. The program will be friendly, interactive and usable by mainstream engineers.

A design protocol and software package will be developed to facilitate progressive evaluation of quarry highwalls as mining progresses. This package will include an optimum design protocol that can be followed to avoid the potential of massive failure. Deterministic evaluations and probabilistic analysis will be available in the slope stability program. A system of help menus will be incorporated into the program to assist in its use.

## **CHAPTER II. - LITERATURE REVIEW**

### **2.1 Properties of Rock in the Stability of Slopes**

The stability of natural and artificial rock slopes is controlled in large part by properties of the rock and by the properties of the rock mass. From the engineering perspective, rock properties grade from intact rock to those of a rock mass. Intact rock may be defined as relatively uniform rock of a single petrographic type that does not contain significant mechanical defects. A rock mass consists of mass of sufficient size to contain representative samples of the mechanical defects. Joints, faults, and bedding planes, commonly referred to as discontinuities, are the recognized sources of most defects. While the strength of the rock is the strength of the substance, the strength of the rock mass is predominantly the strength of the discontinuity bond (Mueller, 1964). The characteristics of intact rock are primarily related to processes such as drilling, crushing, and grinding. However, it is the rock mass and its associated discontinuities that play the most important role in slope stability (Obert, 1973).

#### **2.1.1 Rock Mass**

The characteristics of a rock mass are the result of a rock formation's geologic history. Incorporated in the rock mass are the genesis of formation, whether by igneous, metamorphic, or sedimentary mechanism, and the chronicle of tectonism resulting from plate movements. Other stress related mechanisms, including erosion of overburden are also incorporated into the rock mass characteristics. The integrity of a rock mass is high when its properties approach those of the intact rock. When the integrity of a rock mass is low its properties approach those of soil. In general and traditionally, the mechanics of stability for rock slopes and soil slopes are separate and distinct.

Many methods of quantifying rock mass have evolved through time in the mining and tunneling industry. These methods have the common purpose of classifying on the basis of similar behavior, providing a foundation for determining mechanical and physical properties, obtaining quantitative data for engineering purposes, and achieving a common standard for communications (Afrouz, 1992). These methods include Rock Quality Designation (RQD), Rock Mass Quality System (Q), Rock Quality Index (QI), and Rock Mass Rating (RMR). Each of the methods measures and incorporates a specific set of geologic and geotechnical parameters. The RQD (Deere, 1967) is a quantitative index on rock integrity based on the proportion of core recovered from a drill hole that is greater than 100 mm. Q (Barton, 1974) is a system of classification developed from tunnel research at the Norwegian Geotechnical Institute that includes RQD and several strength parameters. QI (Fourmaintraux, 1976) is a method that correlates longitudinal seismic velocity with the fissured or porous rock mass. RMR (Bieniawski, 1974) is a classification based on the rock mass properties: intact rock strength, RQD, joint spacing, condition of joints (smoothness, weathering, etc.), condition of groundwater, and orientation of discontinuities with respect to area under consideration (Table 2.1). Many other methods have been developed and each is designed to facilitate evaluation of a unique situation at hand. All of the methods permit description of the rock mass.

### **2.1.2 Discontinuities**

Physical discontinuities are present in all rock masses in the form of planes or surfaces of separation. These mechanical defects of rock are recognized as joints, faults, bedding planes, or rock cleavage planes (Terzaghi, 1946). The permeability, shear strength, and deformability of a rock mass are all influenced by the number and kind of discontinuities in the rock mass.

Table 2.1 - Rock Mass Rating (RMR) Classification  
(after Bieniawski, 1974)

Class	Description of Rock Mass	RMR - Sum of Rating Increments
1	Very Good Rock	81-100
2	Good Rock	61-80
3	Fair Rock	41-60
4	Poor Rock	21-40
5	Very Poor Rock	0-20

Fractures are breakage surfaces in rock of geologic and man-made origin. Fractures are known to develop in response to stress relief adjacent to folds and faults. Overblasting of benches in quarries has the same general effect.

Faults are major geologic structures that are large enough to be mapped and located as individual structures. In general, faults imply movement on the discontinuity at some time in the geologic past. However, faults may be of no more importance than any other rock discontinuity, except when the gouge is generated or roughness is reduced.

### 2.1.3 Continuity

Continuity is the proportion of discontinuous rocks in a fracture plane and is commonly expressed as a percent. Continuity may be defined as:

$$C = \frac{A - A_g}{A} * 100$$

where

C = continuity

A = total area of the section through the rock

and

$A_g$  = total area of gaps within the section

(Call, 1972).

Values for  $A_g$  are difficult to measure and impractical to obtain. Joint property classification systems commonly include categories for continuity based on the percentage of rock that cuts through joints. Division of continuity into five categories of 8, 16, 33,

67, and 100% has been used by the DeBeers Mining Company as shown in Table 2.2 (Stacey, 1968).

#### **2.1.4 Spacing**

Spacing is the distance between fractures measured along the normal to the fracture set and is a general indication of block size (Call, 1972). Both the mean and the mode have been used to describe the spacing of fracture sets (John, 1962). Descriptive terminology related to spacing includes "widely" and "closely" spaced (Franklin and Dusseault, 1989).

#### **2.1.5 Attitude**

Stereographic contouring, vector averaging, and arithmetic averaging are methods of representation of a fracture from a set of measurements.

Spherical graphing on hemispherical projections provides the most convenient method of estimating the central tendency of a fracture set. The poles of each plane are plotted on an equal-angle or equal-area stereograph, and isopachs representing portions of the total set are constructed. While many methods of contouring stereographic projections have been used in the synthesis of geologic data, the Denness curvilinear cell counting method has gained the widest acceptance. In the Denness method a transparent cell counting net of either equal-area or equal-angle design is laid on the stereographic plot, and the number of poles in each cell is recorded. Contours of equal pole density are obtained by joining identical numbers or scaling between higher and lower values, and they are usually expressed as a percent (Hoek and Bray, 1991).

The most rigorous method of estimating the central tendencies of a set of fractures is by use of directional cosines that may be represented by the equations:

Table 2.2 - Joint Property Classification System  
 (after Stacey, 1968 and modified for rock only)

Roughness of Joint faces	Waviness of the Joint for a 24 inch base length	Continuity of Joints	Gouge Thickness	Hardness of Joint Material
Slickensided	> 2.0 inches	8 % cuts through joints, balance solid material	No gouge at all	Very Soft
Smooth	1.0 to 2.0 inches	16 % cuts through joints, balance solid material	0 to 0.5 inches	Soft
Defined Ridges	0.50 to 1.0 inches	33 % cuts through joints, balance solid material	0.5 to 1.0 inches	Hard
Small Steps	0.25 to 0.5 inches	67 % cuts through joints, balance solid material	1.0 to 2.0 inches	Very hard
Very Rough	0 to 0.25 inches	100 % cuts through joints	> 2.0 inches	Very, very hard

$$\bar{x} = \frac{\sum_{i=1}^n u_i}{n}$$

$$\bar{y} = \frac{\sum_{i=1}^n v_i}{n}$$

$$\bar{z} = \frac{\sum_{i=1}^n w_i}{n}$$

where

$u, v, w$  = the directional cosines

and

$n$  = the number of fractures.

Comprehensive field studies have shown that the mean attitude can be approximated by the arithmetic mean strike and by the arithmetic mean dip when the range of attitudes is less than 104 degrees (Agterberg, 1961).

### 2.1.6 Dispersion

The dispersion of a joint set is a measurement of the spread of measured values around a central value. Statistical distributions including the spherical normal have been used to characterize fracture set data (Fisher, 1953), and statistical methods for analyzing vector oriented data have been developed (Watson, 1966). For limited ranges of strike and dip, the conventional variance and standard deviation can be computed (Mueller, 1964).

### **2.1.7 Fabric**

Rock fabric is a term applied to the sum of all textural and structural features. Fabric incorporates all of the recognizable elements of rock, from the crystal lattice of its constituent minerals to the large scale features that require field investigation. Fabric is commonly portrayed by stereographic plots. Determinations of fabric include whether or not a fracture pattern has preferred orientation or is random. Usually, a large number of measurements with a Brunton compass is necessary to identify preferred orientations from random scatter. In less complex structural areas, a few quick measurements showing a close cluster may be sufficient to identify preferred orientations. Once anisotropic fabric has been identified, interpretations of the geologic history and associated stress and displacement history may be developed. Though these interpretations are usually uncertain and unsubstantiated, they do offer some insight into the behavior of the rock under evaluation (Agterberg, 1961).

### **2.1.8 Geologic Characteristics**

The lithologic description of a rock refers to the geologic name given to the rock type based on its mineralogic composition, texture, and in some cases its origin. Additional information includes grain size, color, and minor mineral constituents to complement the description.

The density of the rock constituting a slope is an important stability parameter that results from a combination of mineralogy and porosity. Rocks composed of granitic minerals are typically more dense than rocks composed of carbonate minerals. Porosity is a measure of open space within the rock that reduces density. Of two rocks with the same mineral assemblage and ratios, the one with the lower porosity is more dense. Rocks with higher density apply a greater normal force to a discontinuity than less dense rocks but also generate a greater shear force.

Bedding planes are surfaces of natural separation in sedimentary rocks caused by inhomogeneity of deposition. In many carbonate quarries, the bedding plane is the most influential discontinuity under consideration.

Foliation is the parallel orientation of platy minerals or mineral bands. In metamorphic rock quarries foliation planes may represent the controlling discontinuity.

### **2.1.9 Mineralization of Discontinuities**

Mineralization of a discontinuity by movement of groundwater through it may effect the stability of a rock slope. The term "healed" implies mineralization of the discontinuity. The sheet silicate minerals chlorite, muscovite, biotite, serpentine, and talc are associated with reduced discontinuity strength (Goodman, 1976).

## **2.2 Hydrology**

The hydrologic cycle is a closed natural system that can significantly affect the stability of excavated rock slopes. The basic components of the hydrologic cycle include precipitation, evaporation, evapo-transpiration, infiltration, overland flow, and stream flow. Precipitation and infiltration are the critical components of the hydrologic cycle that most influence slope stability.

### **2.2.1 Precipitation**

Precipitation is the primary input quantity of the hydrologic cycle and is derived from atmospheric moisture in the form of rain, snow, and hail. A variety of precipitation data is available in the form of maps and tables from the National Weather Service and from the U.S. Geological Service, based on the rain gauge network cooperatively maintained by these federal agencies. Available data includes national and regional maps of "average annual precipitation" and city by city "normal monthly distribution" of

precipitation. The erratic nature of precipitation gives rise to characterization through probability theory, where it is used extensively to analyze the magnitude and frequency of rainfall. Precipitation data from a long time series can be fitted with a line to form intensity-duration-frequency (IDF) curves for 2, 5, 25, 50, and 100-year design storms (Gumbel, 1958). IDF curves are available from the federal government and from most state governments.

### 2.2.2 Infiltration

Infiltration is the movement of water into soil and rock under gravity and capillary forces and is the result of complex interaction between rainfall intensity, soil/rock types, and surface conditions (Horton, 1933). Infiltration occurs when soil and rock have the capacity to absorb rainfall. When the precipitation rate exceeds the absorption rate, water enters the ground at a rate that decreases with time (Horton, 1940).

Means of estimating infiltration include the Horton method and the F Index method. Both methods are empirically based on observations at the ground surface. The Horton method assumes that infiltration decreases with time and is modeled by the equation:

$$f = f_c + (f_o - f_c)e^{-kt}$$

where:

- f = infiltration capacity (in./hr.)
- f<sub>o</sub> = initial infiltration capacity (in./hr.)
- f<sub>c</sub> = final infiltration capacity (in./hr.)
- k = empirical constant (hr.<sup>-1</sup>)

and

- t = time (min.).

The F Index method is the simplest estimator of infiltration. In this method infiltration is assumed to be constant. The rate of infiltration is determined as the difference between the precipitation rate, determined from the rain gauge network, and the surface runoff rate as determined from the stream gauge network (Bedient, 1992).

### 2.2.3 Groundwater Movement

The movement of groundwater is well established by the hydraulic principles. These principles rest firmly on the concept that flow rate through a porous medium is proportional to head loss and inversely proportional to length of flow path. Groundwater movement can be related by the equations:

$$Q = kA \frac{\Delta h}{\Delta s}$$

and

$$V = -\frac{Q}{A} = -k \frac{\Delta h}{\Delta s}$$

where

- Q = discharge
- V = velocity
- k = coefficient of permeability
- A = cross-sectional area
- $\Delta h$  = change in height

and

- $\Delta s$  = change in length

(Morgenstern, 1971).

The role of rock mass is fundamental in the hydrologic control of groundwater flow and slope stability. Rock masses with tight discontinuities are capable of attaining excessive pressures with limited discharges. Tightness is a measure of the coupling of the two halves of a discontinuity surface. Two surfaces that fit together with no gaps and with no evident alteration are considered tight or closed. The interlocking nature of tight discontinuities allows the gradual build-up of pore pressure while inhibiting discharge.

Fracture walls that do not fit together or where alteration material and staining are evident are described as loose or open. Loose or open discontinuities promote the flow of groundwater. Rock masses with loose discontinuities and with frequent periods of high rainfall intensity are susceptible to very high instantaneous pore pressures. This may be especially possible when the recharge area of the slope is greater than the discharge area of the slope face. Increases in pore pressure may be assisted by preferential flow directions within the rock mass.

The term, cavernous, is associated with carbonates, the dissolution of rock material, and loose discontinuities (Plate 2.1). Cavities and caves are attributed to a rock slope failure of greater than 600 feet in southwest Virginia (Plate 2.2). This mechanism of destabilization is associated with increased mobilization of groundwater in response to high intensity precipitation. Since carbonate quarries represent a very large portion of quarry production in the U.S., this parameter may represent the most important geotechnical mechanism in quarrying today.

Flow direction and velocities in most real geologic systems tend to vary in more than one direction due to preferential orientation of discontinuities. In sedimentary rocks these variations are additionally attributed to conditions of deposition. In general, flow directions are difficult to predict with confidence, and the best results are obtained from direct measurements in the rock mass (Huitt, 1956).



Plate 2.1 - Dissolution of Carbonate Rock

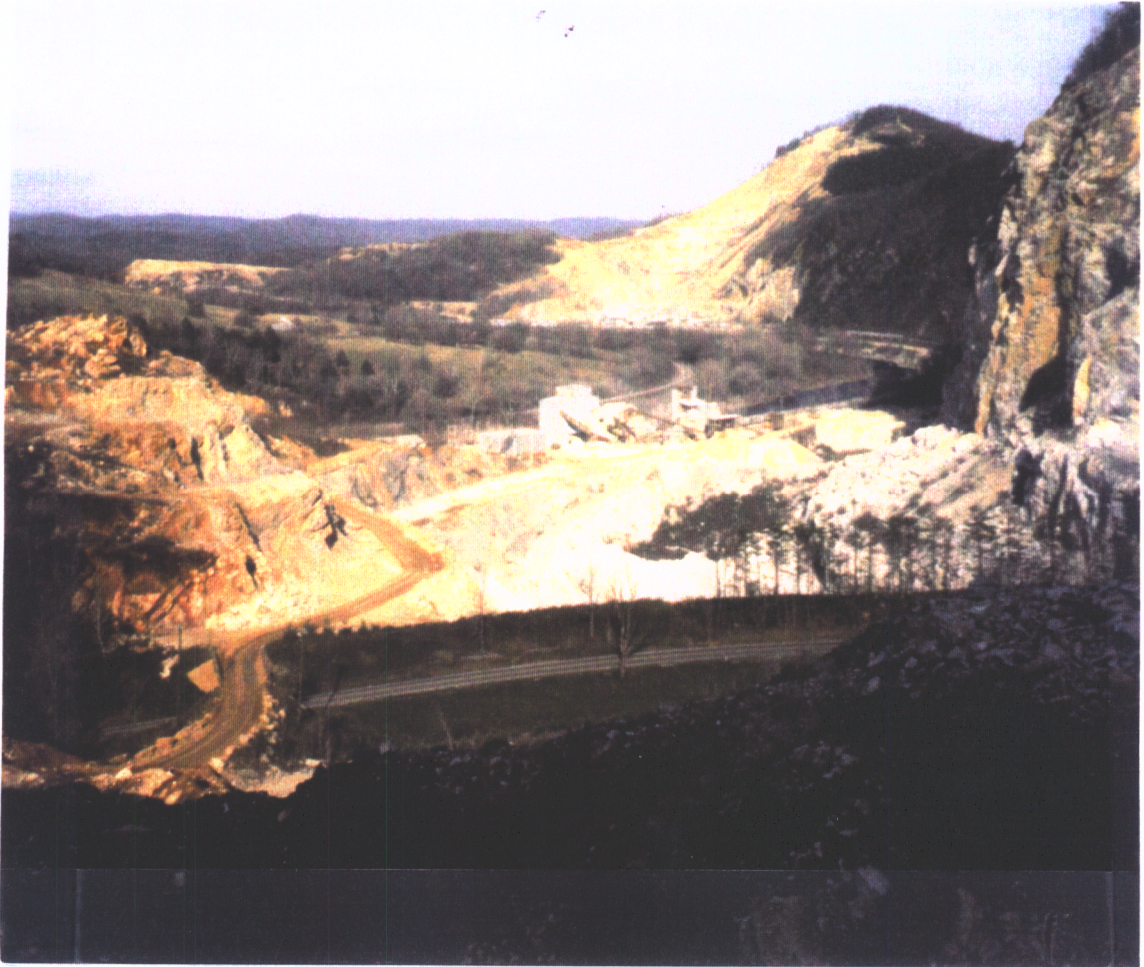

Plate 2.2 - Rock Slope Failure in Southern Virginia (on ridge in background)

Groundwater flow may be graphically represented in the second and third dimension by flow nets that are developed from the intersection of flow lines and equipotential lines (Figure 2.1). Equipotential lines connect points of equal head. Flow lines represent the paths followed by individual particles of water through the saturated underground media that are orthogonal to the equipotential lines. Flow nets are commonly constructed by analog and numerical methods that allow evaluation of variations in groundwater conditions (Zienkiewicz, Mayer, and Cheung, 1966).

The groundwater table defines the boundary between saturated and unsaturated zones in rock and represents the equilibrium surface where water pressure is exactly atmospheric. Where the water table is above a discontinuity, head pressure can develop between the elevation of the water table and the elevation that the discontinuity "daylights" in the slope face. This pressure reduces the normal force applied to the discontinuity by the weight of the overlying rock through buoyant up-lift. Depending upon the height of the water table and surrounding topography, frictional resistance may be reduced by as much as 37% (Brawner, 1968).

#### **2.2.4 Permeability**

The coefficient of permeability is a measure of hydraulic conductivity of a soil or rock. Permeability depends on a variety of factors and is an indication of rock mass's ability to transmit water. Limestone and dolomite have permeabilities ranging between  $6 \times 10^{-4}$  and  $1 \times 10^{-7}$  as shown in Table 2.3. Because permeability can vary over many orders of magnitude, velocities and flow rates in a rock mass can vary over the same range.

#### **2.2.5 Effect of Gouge**

The composition of fill material or gouge within a discontinuity and the permeability of the rock mass can work together to significantly influence the stability of

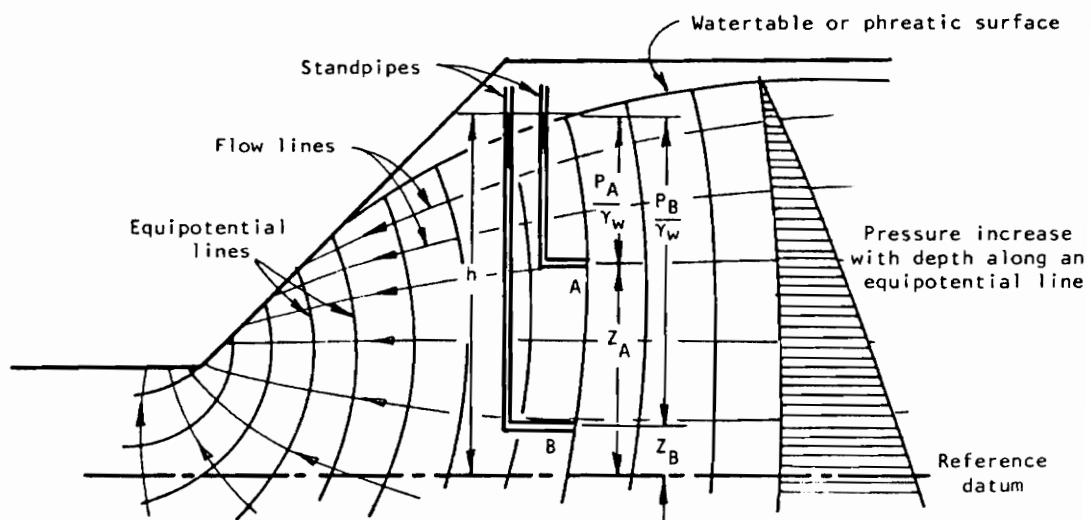

Figure 2.1 - Flow Lines and Equipotential Lines Within a Slope  
(Hoek and Bray, 1991)

Table 2.3 - Coefficient of Permeability for Various Types of Rock  
(after Bedient, 1992)

Rock Type	Hydraulic Conductivity
<b>Sedimentary Rocks</b>	
Karst Limestone	2 to $1 \times 10^{-4}$
Limestone and Dolomite	$6 \times 10^{-4}$ to $1 \times 10^{-7}$
Sandstone	$6 \times 10^{-4}$ to $3 \times 10^{-8}$
Shale	$2 \times 10^{-7}$ to $1 \times 10^{-11}$
<b>Crystalline Rocks</b>	
Permeable Basalt	2 to $4 \times 10^{-5}$
Fractured Igneous and Metamorphic	$3 \times 10^{-2}$ to $8 \times 10^{-7}$
Basalt	$4 \times 10^{-5}$ to $2 \times 10^{-9}$
Unfractured Igneous and Metamorphic	$2 \times 10^{-8}$ to $3 \times 10^{-12}$
Weathered Rock	$3 \times 10^{-4}$ to $5 \times 10^{-3}$

rock slopes. While rock fragment fills may allow the free flow of water along a discontinuity, clays and unsorted very fine grained material have the potential to back-up groundwater in pockets and cause the build-up of hydraulic pressures. These water pressure increases directly off-set the normal force on the discontinuity plane and destabilize it accordingly.

Additionally, and no less significant, is the physical effect of water on the fill material of the discontinuity. Hydration of clays, especially montmorillonite (bentonite) can cause softening and swelling. The softening directly reduces the shear strength of the discontinuity while swelling provides a destabilizing up-lift force and accelerates the impermeability along the discontinuity (Hoek and Bray, 1991).

#### **2.2.6 Laboratory and Case Studies**

The effect of water pressure on a slope is illustrated by the well-known beer can on glass experiment, where a length of glass is cleaned and wetted so that it retains a continuous film of water. The angle at which an opened beer can slides is determined for both the upright and upside down positions. The angles are determined to be approximately 17 degrees in both cases. The beer can is then chilled and the tilt experiment is re-performed. When upright, the angle of tilt is determined to be the same as in the unchilled experiment. However, when the chilled beer can is turned upside down, the angle at which sliding occurs is substantially less than 17 degrees. Vapor pressure in the upside down and chilled can increases as the can warms. The pressure increase supports the weight of the can, reduces the normal force that the can applies to the glass, and resistance to shear drops accordingly (Hubbert and Rubey, 1959).

The relationship between water pressure in a slope and slope instability has been exhibited in field studies that correlate horizontal and vertical displacement in the slope

with water pore pressure and rainfall. In these cases, it was determined that movements in the slope were a direct response to rainfall and increased rates of infiltration. As water pressure in the slope decreased so did the movements. When rainfall decreased due to seasonal changes, movements in the slope subsided. When rainfall again increased, pore pressure in the slope increased and movements recurred (Morgenstern, 1971).

### **2.3 Seismic Acceleration**

The shock wave from an earthquake can exert temporary additional stress on a slope and increase instability. Landslides triggered by earthquakes in California and Alaska are a matter of record. However, the magnitude of these failures is misleading with regard to rock slopes due to additional acceleration caused by liquefaction of saturated soils (Glass, 1982). Seismic acceleration in rock slopes has traditionally been accounted for by either the equivalent-static load or the pseudo-static load approaches.

#### **2.3.1 Equivalent-static Load**

The classic method of accounting for the effect of an earthquake is the equivalent-static load approach. With this method, the response of a specific slope geometry to seismic acceleration is a function of the frequency and duration of the ground movement. This approach treats an earthquake as an internal load applied to center of mass of a slope. The magnitude of the force applied to the slope is the product of the structural mass and a seismic coefficient. The seismic coefficient has historically been chosen based on experience and judgment. Seismic zones in the U.S. and Canada have been assigned seismic coefficients and associated damage criteria as shown in Table 2.4 (U.S. Army, 1977).

**Table 2.4 - Seismic Zones and Associated Damage**  
(after U.S. Army, 1977)

<b>Zone</b>	<b>Damage</b>	<b>Coefficient</b>
0	None	0
1	Minor	0.025
2	Moderate	0.05
3	Major	.10
4	Great	0.15

### **2.3.2 Pseudo-static Load**

The pseudo-static load approach incorporates the maximum horizontal forces initiated by the earthquake into the stability analysis. Tools in determination of horizontal stress include probabilistic analysis of the historical record. A time history acceleration of the slope can be developed by using empirical attenuation relationships to convert the magnitude and distance for each earthquake event. The probability of site accelerations for time intervals can be estimated by Gumbel extreme value methods.

Linear Acceleration Dynamic Response (LADRS) techniques have been developed to estimate the displacement due to seismic activity. In this technique, the displacement is calculated at short time increments using a digitized model accelerogram. Displacement is summed over the accelerogram. Stability criteria is expressed as the maximum permissible displacement specific to the site. Maximum displacements of 8 to 12 inches have been recommended for slopes without facilities. Displacement tolerances have been recommended where structures are present (Glass, 1982).

## **2.4 Stability Criteria**

The orientation and strength of discontinuities within the rock mass control the stability of rock slopes. Mohr-Coulomb strength criteria is the foundation of the most accepted rock slope stability analysis. Modifications to the Mohr-Coulomb equation that account for increases and decreases in strength include the effect asperities, water pressure, and seismic acceleration. Together these modifications improve this strength estimation. Empirical equations based on estimates of roughness have been developed to predict the shear strength of joints. Increases in discontinuity strength due to bolts and cable anchors are not considered due to theoretical problems associated with reinforcement at conditions other than limiting equilibrium (Hoek and Bray, 1991).

### 2.4.1 Mohr-Coulomb Strength

The most generally accepted rock slope stability analyses are based on interpretations of Mohr-Coulomb total stress criteria that is related by the linear equation:

$$T = \sigma \tan(\phi) + c$$

where

T = shear strength

c = cohesion

$\sigma$  = normal stress

and

$\phi$  = angle of internal friction.

Discontinuity strength is usually determined by direct shear test. In this test, the shear strength of the discontinuity (T) is determined by varying the shear force applied to a discontinuity while holding a constant normal force and measuring the displacement of the blocks on either side of the discontinuity. At low stress levels the sample reacts linearly due to the elastic properties of the rock sample. As the shear force approaches the shear strength of the discontinuity, the curve behaves non-linearly and the peak shear stress of the sample is attained. After displacement at the peak shear stress, the force required for additional displacement drops to a constant value. This constant value defines the residual shear strength of the discontinuity.

The displacement test is repeated at various normal stress levels that approximate conditions expected in the slope under evaluation. A plot of the test results yields a line that defines the failure envelope. Shear stress and normal stress combinations above the plot may be expected to result in movement of the discontinuity and failure of the slope.

Shear stress and normal stress conditions below the plot may be expected to be stable. The slope of the plot defines the friction angle ( $\phi$ ) of the discontinuity. The origin intercept defines the cohesive strength ( $c$ ) of the discontinuity.

#### 2.4.2 Asperities

Undulations, or waviness of a discontinuity, cause a change in the relationship between the discontinuity surfaces that affects both shear and normal stresses. When the discontinuity surface along which shearing occurs is not parallel to the shear direction, the shear strength of the discontinuity is equal to the cohesion plus the product of the normal stress and the tangent of the sum of the friction angle and the angle between the surface of the discontinuity and the shear stress direction. Shear and normal stress acting on the discontinuity are determined by the equations:

$$T_i = T \cos^2(i) - \sigma \sin(i) \cos(i)$$

and

$$\sigma_i = \sigma \cos^2(i) + T \sin(i) \cos(i)$$

where "i" is the inclination of the discontinuity surface to the shear stress direction.

For the case of zero cohesion:

$$T_i = \sigma_i \tan(\phi)$$

so that the applied shear and normal stresses are:

$$T = \sigma \tan(\phi + i)$$

(Patton, 1966).

Undulations of discontinuity surfaces and the associated angle of inclination with the shear plane are described in terms of roughness. "First order" roughness corresponds to primary bumps on the discontinuity. "Second order" roughness corresponds to smaller scale, steeper-angled ripples on and between the primary bumps. "First order" projections are the more important undulatory control of slope stability. "Second order" projections are influential only at low stresses where very little shearing of the ripples occurs. As normal stresses increase, the "second order" projections are reduced through shearing and the less steep "first order" projections control stability. As normal stresses increase further, the undulations are sheared so that the effective roughness angle and the associated increase in strength approach zero (Barton, 1973). Analysis of failed slopes shows that the effective roughness angle "i" varies as much as 40 degrees (Goodman, 1970).

An accompanying product of the shearing of discontinuities is dilation resulting from shear displacement " $u$ " and the normal displacement " $v$ ". Dilation and strength were shown to be theoretically and experimentally related by the portion of intact rock sheared by movement on the discontinuity plane, the rate of dilation ( $dv/du$ ), and the shear strength of the intact rock (Landanyi and Archambault, 1970). The shear strength of the rock on the discontinuity plane was shown to approximate the equation of a parabola. The uniaxial compressive strength of the rock material adjacent to the surface of the discontinuity and the ratio of the uniaxial compressive strength to the uniaxial tensile strength of the rock material express this relationship (Fairhurst, 1964).

Alternatively, an empirical equation based on an estimate of roughness using a schematic profile has been developed to predict the shear strength of rough joints. The

discontinuity is assigned a "joint roughness coefficient" (JRC) that is related to the logarithm of the ratio of the uniaxial compressive strength of the rock to the normal stress acting on the plane (Barton, 1973).

### 2.4.3 Water Pressure and Seismic Acceleration

Effective stress considers decreases to a body force within the rock slope that are caused by the pore pressure of water "u" and the acceleration "α" due to seismic activity (Merrill, 1973). This relationship is expressed in a linear equation similar to that of total stress; however, the effective contribution of other pressures is directly subtracted from the normal stress as in the equation:

$$T = c' + (\sigma - u - \alpha) \tan(\phi)$$

where

T	=	shear strength
c'	=	component of cohesion
σ	=	normal stress
u	=	up-lift water pressure
α	=	seismic acceleration

and

φ	=	component of internal friction angle.
---	---	---------------------------------------

The uplift water force "u" and push-out force "v" along a discontinuity may be incorporated into effective stress by approximation of a triangular distribution as in the equations:

$$U = \frac{0.5\gamma_w z_w (H - z)}{\sin(\Psi_p)}$$

and

$$V = 0.5\gamma_w z_w^2$$

where

U	=	hydraulic uplift
V	=	hydraulic push-out
H	=	height of the slope
$\Psi_p$	=	dip of discontinuity plane
z	=	depth of tension crack
$z_w$	=	height of water in the tension crack

and

$\gamma_w$  and  $\gamma_w$  = densities of rock and water.

The triangular distribution assumes zero hydraulic pressure where the discontinuity 'daylights' in the main slope face and upper slope face (Figure 2.2). In the case of a tension crack in the upper slope face, the hydraulic pressure is assumed to decrease linearly from the intersection of the tension crack and discontinuity to the slope face.

#### 2.4.4 Discontinuity Filling Material

The filling of a discontinuity with clay and rock debris, collectively referred to as gouge, can decrease the strength of a discontinuity. Discontinuities may be filled with detrital material by deposition of very fine sediments (clay) derived from the overlying soil, or from precipitation of minerals associated with groundwater movements.

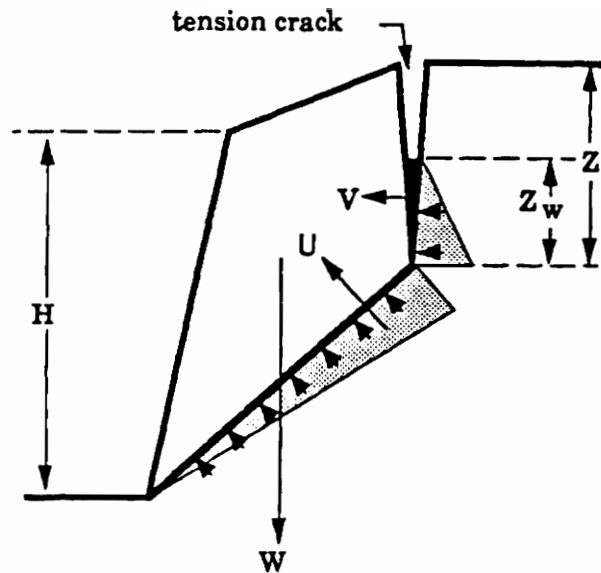

- H = height of slope
- Z = depth of tension crack
- Z<sub>w</sub> = depth of water in tension crack
- W = weight of block
- F = water pressure acting on slope face
- U = uplift pressure on water under block
- V = water pressure acting behind block

Figure 2.2 - Triangular Distribution of Water Pressure in a Rock Slope  
(after Hoek and Bray, 1991)

Degradation of asperities of the rock contact due to past tectonic movement may result in rock fragments that weather and decompose to clay or other fine grained rock/soil types.

For fill thickness less than or equal to the amplitude of the asperities of the discontinuity, the decrease in shear strength is proportional to the increase in filling thickness. For filling material thicknesses greater than the amplitude of the asperities, the strength of the filling material controls the strength of the discontinuity (Goodman, 1970).

Laboratory tests of filled discontinuities show that peak cohesive strengths vary from zero in marlaceous limestone joints to  $7.4 \text{ kg/cm}^2$  in stratified quartzite joints filled with thin laminate of clay (Serafim and Guerreiro, 1968). Other tests of filled discontinuities report peak friction angles from 7.5 degrees in chalk joints filled with montmorillonite clay to 41 degrees in stratified quartzites filled with thin laminate of clay (Underwood, 1968).

## **2.5 Methods of Deterministic Analysis**

Though many deterministic methods of rock slope stability analysis have evolved through time in the mining industry, limiting equilibrium and finite elements are generally the most accepted.

### **2.5.1 Factor of Safety**

The classical deterministic measure of slope stability is the factor of safety that allows comparisons of slope stability based on limiting equilibrium. Limiting equilibrium is the condition at which the forces that induce sliding are exactly balanced by those forces that resist sliding. The factor of safety may be defined as the ratio of the total force available to resist sliding divided by the total force tending to induce sliding. When the safety factor equals one, those forces are exactly stable. A safety factor of less than one

indicates an unstable slope. A safety factor greater than one indicates that a slope contains elements of stability. As a conservative adjustment against the uncertainty of parameters selected for stability evaluation, safety factors of less than 1.5 have traditionally been used in the mining industry to indicate instability in a slope (Hoek and Bray, 1991).

### **2.5.2 Finite Element**

The finite element method of stress analysis utilizes a continuous two- or three-dimensional mathematical model made up of interconnected elements to evaluate stability. Various mathematical models are available and all are varieties of the total stress or effective stress methods based on the linearization of displacement equations developed from the theory of elasticity. Because each element may be assigned independent mechanical properties, and because computers may be used to simulate these complex relationships, the model yields accurate solutions (Merrill, 1973). Because this analysis can be programmed to include discontinuities or various loading and sliding parameters through assignment of boundary conditions, this method is especially attractive for simulation of excavation stability. However, interpreting the results of finite element analysis requires considerable skill and experience in slope stability and rock mechanics. For this reason, this method of slope stability analysis has been utilized on a rather limited basis.

## **2.6 Failure Modes**

Evaluations of slope stability require an understanding of the mechanics of movement and geometry of potential failure zones within the rock mass of a highwall. The stability of a slope with regard to plane and wedge failure is controlled by the shear strength of discontinuities within the rock mass. The relationship between shear and

normal stresses along discontinuity planes can best be described by Mohr-Coulomb equations.

### 2.6.1 Plane Failure

Plane failure is the movement within the highwall along a single plane that trends with slope as shown in Figure 2.3 and Plate 2.3. General conditions for the development of plane failure in a slope without contributing hydraulic pressures include :

- i) The failure plane strikes within + or - 20 degrees of the strike of the slope.
- ii) The angle of the failure plane to the horizon is smaller than the angle of inclination of the slope face. This means that the failure surface 'daylights'.
- iii) The angle of the failure plane to the horizon is greater than or equal to the angle of internal friction.
- iv) Release surfaces that provide negligible resistance to sliding are present in the slope and define the lateral boundaries of the slide (Hoek and Bray, 1991).

Most models of plane failure include a tension crack on either the upper slope surface or on the slope face. Studies of tension cracks suggest that they form as a result of small shear movements within the slope. The primary mechanism associated with development of these shear movements is unloading of overburden in excavation of the pit (Barton, 1971). The filling of these tension cracks with water, especially during periods of high precipitation, is considered the primary destabilizing force associated with plane failure. The positioning of the tension crack in any slope stability analysis for plane stability is extremely important.

The factor of safety against plane failure may be determined by the equation:

$$SF = \frac{cA + [W \cos(\Psi_p)] - U - V \sin(\Psi_p) \tan \phi}{\sin(\Psi_p) + V \cos(\Psi_p)}$$

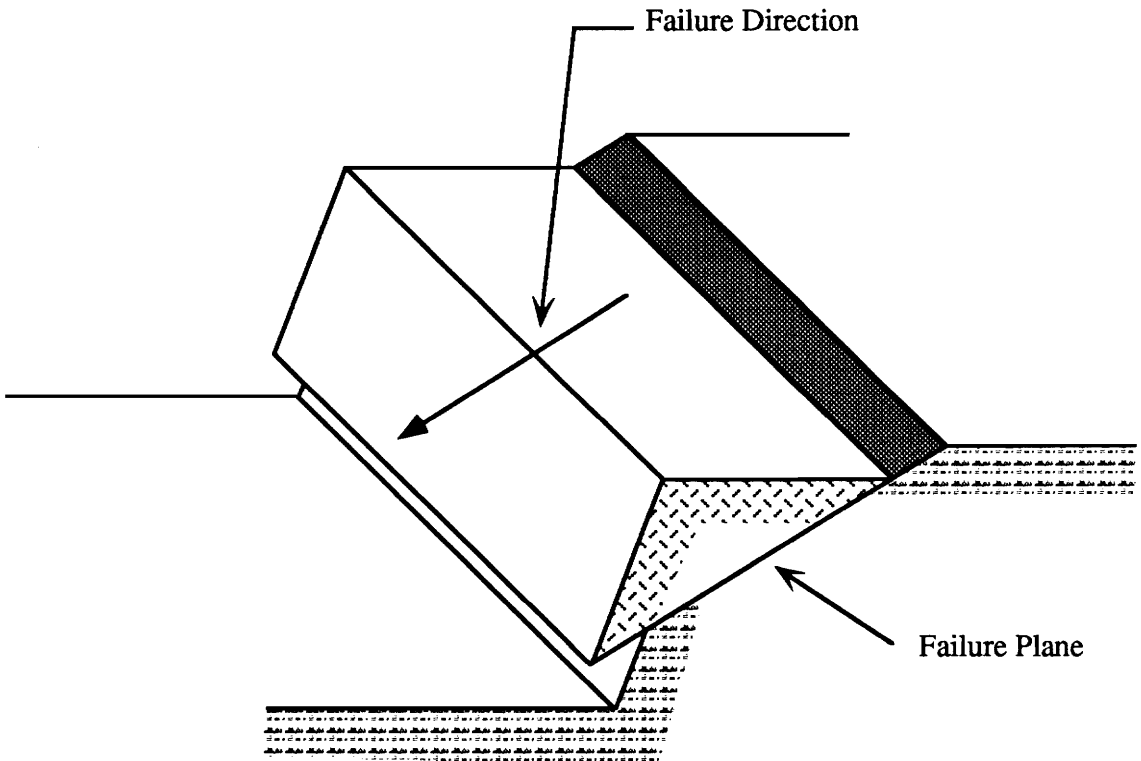

Figure 2.3 - Plane Failure (after Afrouz, 1992)



Plate 2.3 - Plane Failure

where

$$A = \frac{(H - z)}{\sin(\Psi_p)}$$

$$U = \frac{0.5\gamma_w z_w (H - z)}{\sin(\Psi_p)}$$

$$V = 0.5\gamma_w z_w^2$$

(in the case of a tension crack in the upper slope face )

$$W = 0.5\gamma_r H^2 \left\{ \left[ 1 - (z - H)^2 \right] \cot(\Psi_p) - \cot(\Psi_p) \right\}$$

(in the case of a tension crack in the main slope face)

$$W = 0.5\gamma_r H^2 \left\{ \left[ 1 - (z - H)^2 \right] \cot(\Psi_p) (\cot(\Psi_p) \tan(\Psi_f) - 1) \right\}$$

where

A	=	contact surface area of the discontinuity
U	=	hydraulic uplift
V	=	hydraulic push-out
W	=	weight of the overlying rock
H	=	height of the slope
$\Psi_p$ and $\Psi_f$	=	dips of discontinuity plane and slope face
$z_w$	=	height of water in the tension crack
$\gamma_r$	=	density of the rock in the slope
c	=	cohesion

(Hoek and Bray, 1991).

### 2.6.2 Wedge Failure

Wedge failure is movement within the highwall along the intersection of two planes as shown in Figure 2.4 and Plate 2.4. General conditions for the development of wedge failure in a slope without contributing hydraulic pressures include :

i) The dip of the intersection of the two planes is less than the dip of the slope.

If the intersection of the two planes does not 'daylight', the wedge is considered stable.

ii) The dip of the intersection of the two planes is greater than the friction angle of the two planes.

iii) The line of intersection plunges in the same direction as the slope face.

Calculations of safety factors against wedge failure are fundamentally similar to those of plane stability. The normal component of the weight of the overlying rock and roughness of the contact surface tend to stabilize the slope. The shear component of the weight of the rock acting along the line of intersection and hydraulic uplift forces tend to destabilize the slope. Several methods of wedge evaluation, including scaled graphics, spherical projections, and mathematical calculations, have evolved through time in the mining industry.

Engineering graphics is the construction of scaled, two-dimensional models of discontinuity/slope combinations. This method is time consuming and subject to errors of approximately 10% but has the advantage of contributing visual understanding to specific problems (Hoek, Bray, and Boyd, 1973).

Spherical projections use hemispherical stereonet to evaluate wedge stability. Discontinuities and the slope face are represented by arcs and/or poles on the stereonet. The friction angle is represented by a circle on the stereonet. This method allows visualization of general orientations but becomes complex and subject to error when additional stabilizing and destabilizing forces are incorporated. By this method of analysis,

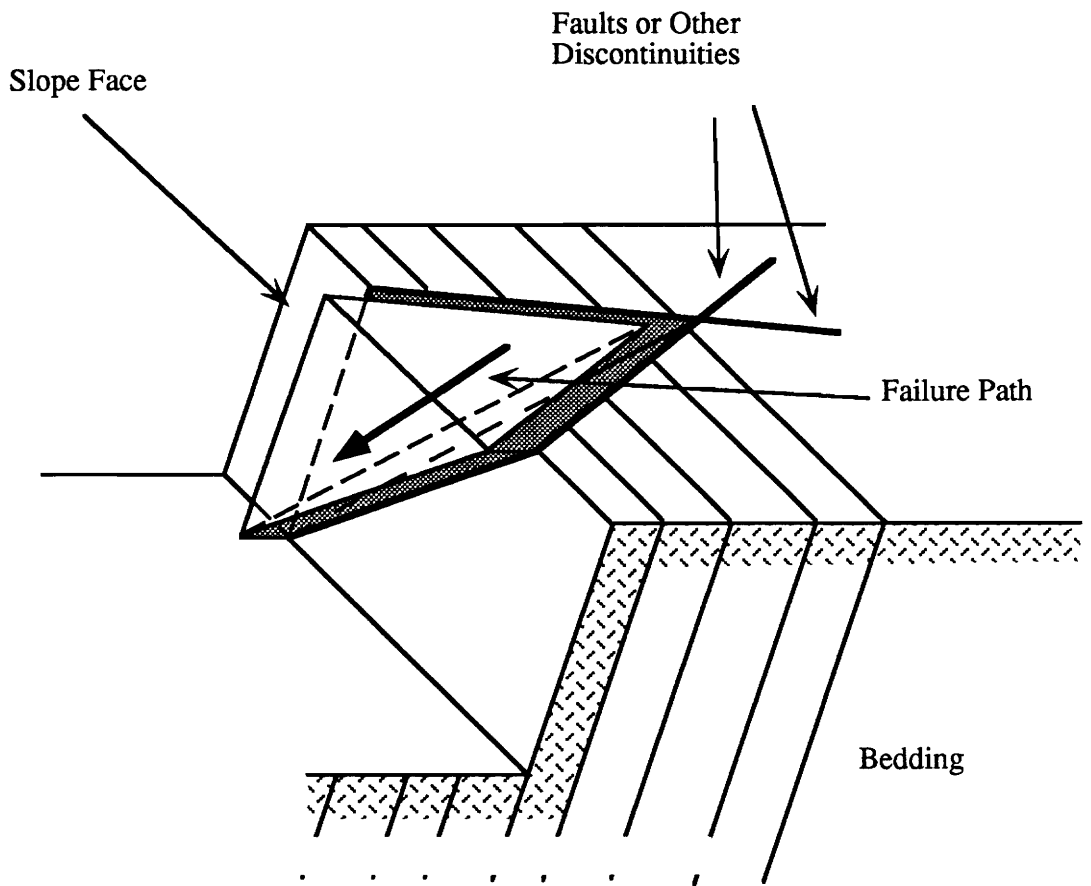

Figure 2.4 - Wedge Failure (after Afrouz, 1992)



Plate 2.4 - Wedge Failure

the two discontinuities, the slope, and the friction circle are projected onto the stereonet. This combination is then evaluated graphically to determine whether or not a unstable wedge forms (Markland, 1972). Failure is possible where plunge of the discontinuity intersection is less than the dip of the slope face ('daylights') and greater than the angle of internal friction.

A qualitative safety factor can be obtained from the stereographic projection for friction-only conditions by measuring the angle between the two discontinuities along their line of intersection ( $\epsilon$ ) and the angle of inclination of the intersection ( $\beta$ ) with the equation:

$$SF_w = \frac{\sin \beta}{\sin \left[ \frac{1}{2} \epsilon \right]} \frac{\tan \phi}{\tan \psi} = SF \times K$$

In this equation, " $SF_w$ " is the safety factor of a wedge supported by friction-only, " $SF$ " is the safety factor that incorporates the lateral restraint developed by the relationship between the slope face and the intersection of the two discontinuities, and " $K$ " is the wedge factor.

The wedge factor " $K$ " depends upon the included angle and tilt of the wedge. The practical implication of the wedge factor is an increase in stability. Figure 2.5 shows that when the included angle of the wedge is less than 90 degrees, safety factor increases of 100 to 200% may be attained (Hoek and Bray, 1991).

Trigonometric and vector methods have been used extensively to evaluate rock slope stability in the mining industry and these means of analysis are most convenient. However, the number of trigonometric calculations necessary to determine a factor of

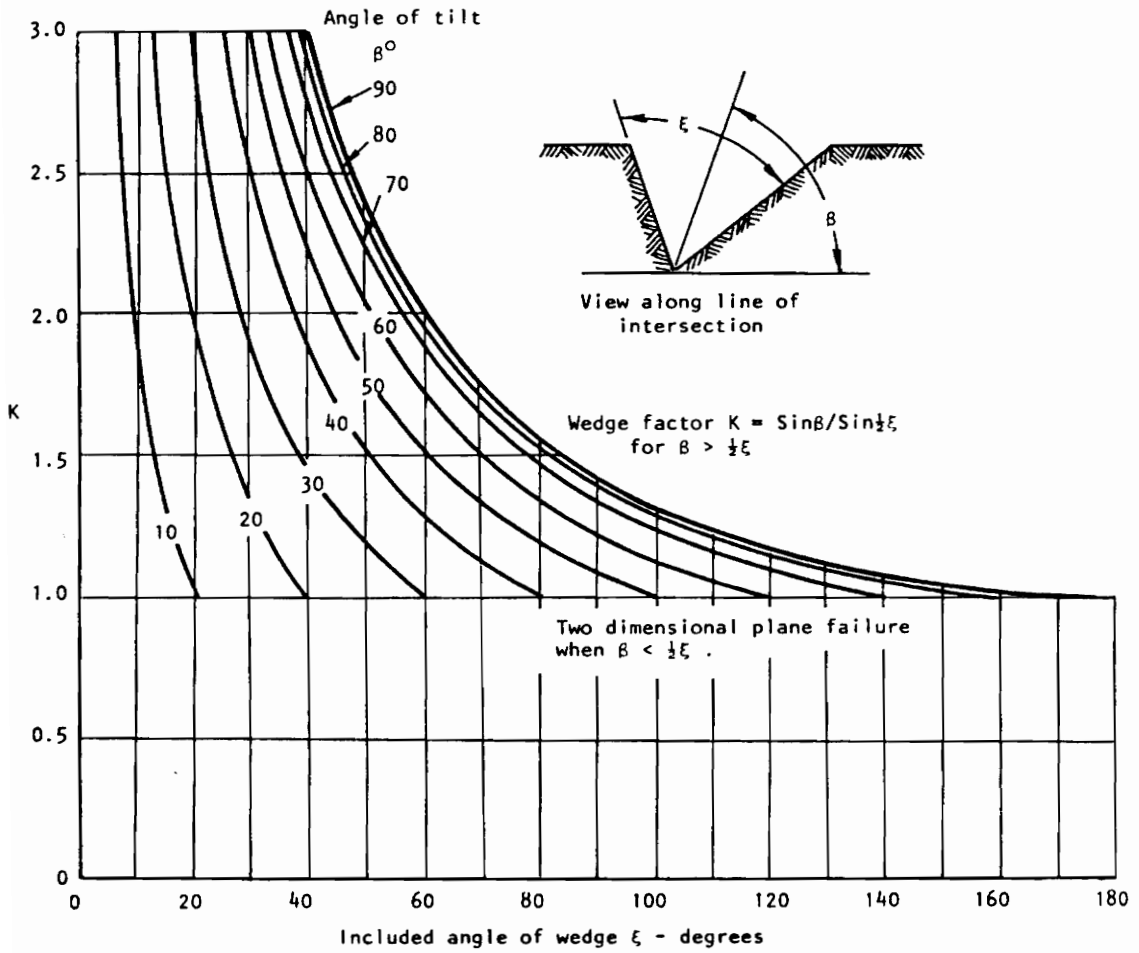

Figure 2.5 - Wedge Factor "K" as a Function of Discontinuity Geometry (Hoek and Bray, 1991)

safety is very large, and vector analysis is not generally well understood by practicing geologists and engineers (Hoek, Bray, and Boyd, 1973).

A universal algorithm for computation of a safety factor against transitional slip of a tetrahedral wedge formed by two discontinuities, the slope face, and an upper ground surface is presented in Appendix 2 of Hoek and Bray's Rock Slope Engineering. The algorithm accounts for differing rock properties on each discontinuity, the geometrical considerations of whether or not a wedge forms, whether or not one of the planes overlies the other, the orientation of the wedge with the slope face, and includes the effect of the wedge factor "K". The algorithm also allows for uplift hydraulic pressures that, in conjunction with wedge geometry, may cause contact to be lost on either or both discontinuity planes. (This algorithm was incorporated into the slope stability program PSLOPE.)

### **2.6.3 Rotational Failure**

Rotational failure occurs along a circular or curvilinear boundary in soil and weathered or crushed rock. The potential for rotational failures exists even in very strong rocks if they are highly fragmented relative to the slope height (Figure 2.6). This type of analysis is complex and is most commonly conducted by means of charts and tables developed from the method of slices. Several computer programs including REAME, SWASE, and GALENA are available for rotational failure evaluation. In general, these programs are valuable analytical tools in the mining industry for evaluations of gob pile and valley-fill stability, but they are limited by the extensive experience and abundant data required to obtain even minimal results.

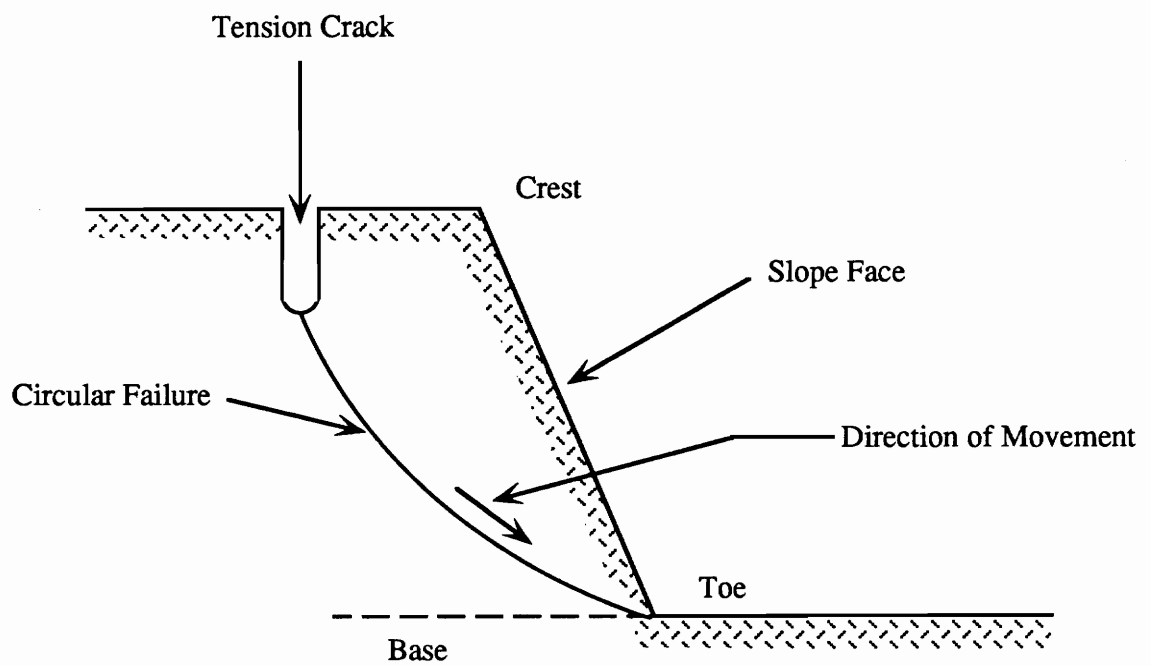

Figure 2.6 - Rotational Failure (after Afrouz, 1992)

#### **2.6.4 Raveling Failure**

Raveling is the small-scale deterioration of slopes due to mechanical degradation as a result of erosion, cyclical freeze/thaw action of water, and reduction of cementing components due to unloading adjustments as shown in Figure 2.7. This method of failure is limited to small, individual pieces of rock that roll off the slope and accumulate at the bottom of the slope through time at the angle of repose. Scree piles and talus at the base of steep slopes identify this mode of degradation. Raveling is, in general, common to nearly all slopes. It is a constant annoyance at all surface mines but does not represent a serious large-scale failure mechanism.

#### **2.6.5 Toppling Failure**

Toppling failure is disintegration of a slope by relatively large columns or blocks of rock that individually rotate out of the slope face from top to bottom as shown in Figure 2.8. The general mechanism of failure for a single block involves movement of the block by an external force such as gravity or the freeze thaw action of ice, so that the center of gravity of the block is outside its base on the side of the open slope face. Toppling may occur in both strong and weak rocks and requires vertical or near-vertical jointing sub-parallel to the slope face.

Most toppling evaluations consider a system of blocks and the interaction between the blocks caused by movement of an initial block. The analysis is extremely complex and is limited by the geometric orientation of the blocks and by the configuration of movement on the individual blocks. One block moves one or more blocks, and so on. In real situations, additional external forces cause more complex changes. Even the smallest variation in geometry and/or application of external force alters the toppling outcome.

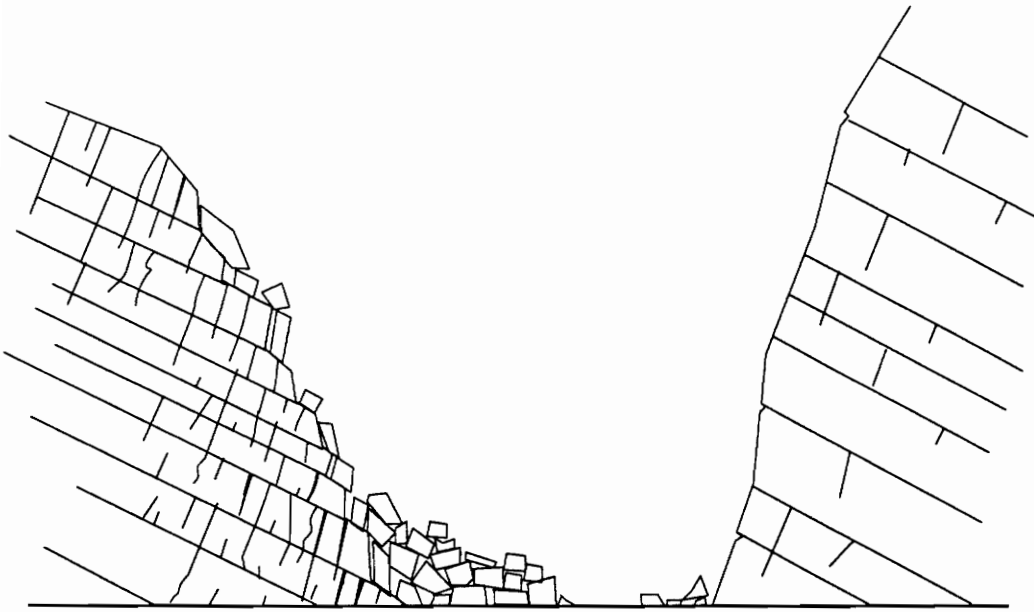

Figure 2.7 - Raveling Failure (after Haycocks et al., 1991)

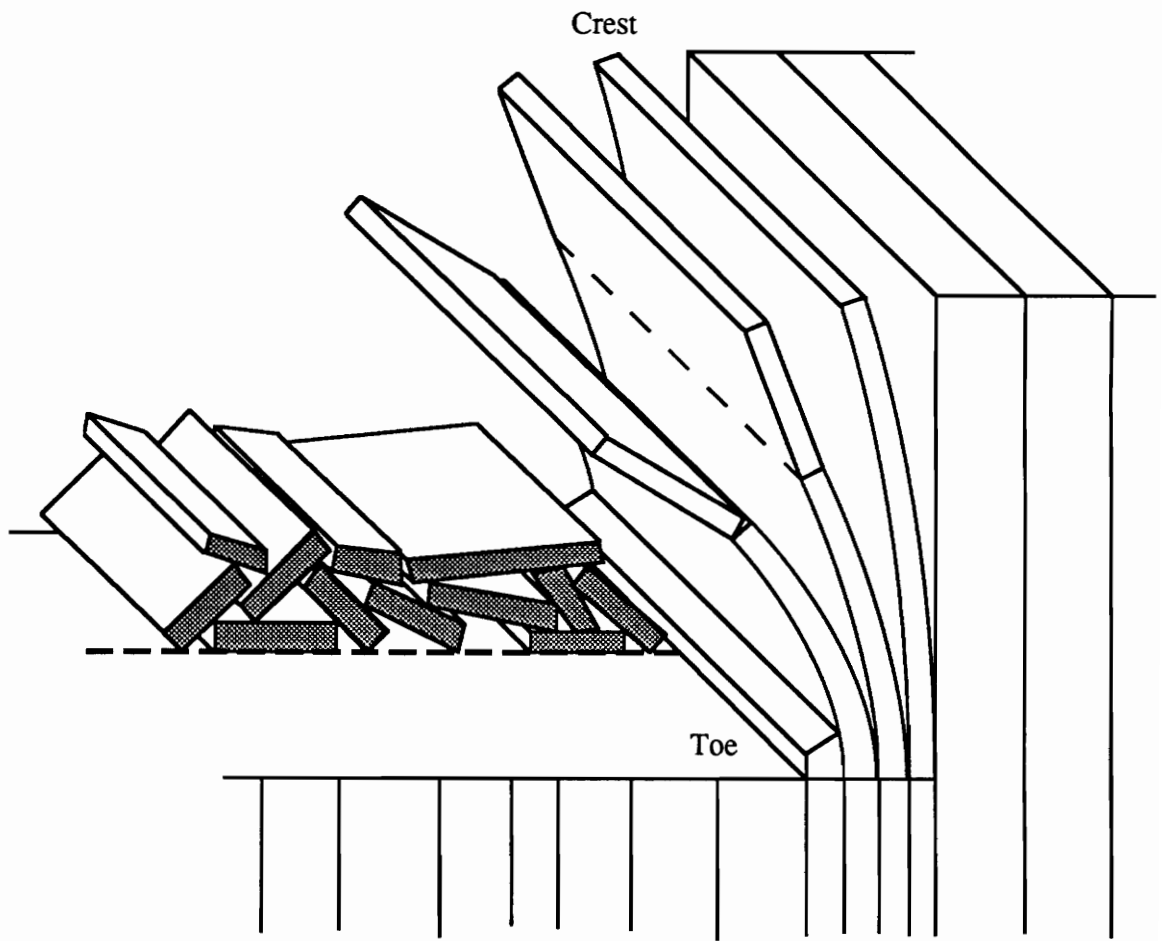

Figure 2.8 - Toppling Failure (after Afrouz, 1992)

## **2.7 Influence of Slope Curvature**

Most evaluations of quarry stability do not consider curvature of the highwall. Curvature within a quarry affects stability by increasing and decreasing lateral constraint on the slope. The additional lateral force is provided by the rock material on either side of the potential failure surface. Studies show that slope inclinations can be increased ten degrees more than the angle predicted by conventional analysis for a concave slope with a radius of curvature less than the height (Piteau and Jennings, 1970). The same studies also showed that convex slopes with a radius of curvature less than the height of the slope should be flattened ten degrees to sustain the predicted safety factor.

## **2.8 Deterministic Stability**

Deterministic stability evaluations calculate a safety factor from a set of data selected as representative of the circumstance. The implications of the calculated factor of safety vary according to use as in operational stability versus long-term stability. Design protocols that recommend safety factor standards have been developed to assist in design of quarry highwalls. While safety factors are indicators of stability, they do not address the magnitude of failure or volume of rock material produced by a failure.

### **2.8.1 Operational Stability and Long-term Stability**

From the operational perspective, slope instability does not necessarily imply slope failure. Unstable areas have been mined successfully in truck and shovel operations where displacements of four inches per day were recognized. Conversely, displacement of only a few inches in an area set up for preparation of aggregate may require extensive repair and cause an operation considerable lost production time (Call, 1992).

The implications of slope instability are altogether different in regard to long-term stability. The stability of slopes designed to stand relatively short lengths of time, as with

an operating quarry, may imply eventual slope failure in an abandoned quarry that must stand for all time.

Design decisions based on conventional deterministic methods work well in areas with prior history and/or where past experience is relevant to a new site. In these cases, the selection of an appropriate factor of safety requires good engineering judgment based on sound interpretation of the data. A safety factor developed through time and experience at one mine may or may not have relevance at a another mine (Chowdhury, 1986)

### **2.8.2 Design Protocols**

Design of highwalls requires a determination of utility and purpose that has an inference to time. Excavation of rock from the active pit implies a relatively short life for the highwall under consideration. Recovery from an area where the slope location and angle are at the ultimate highwall implies a relatively long life.

The highwall of the active producing area is under continuous and generally expert evaluation by the experienced miners working under it. Design of the highwall based on a factor of safety between 1.0 and 1.3 may be operationally acceptable in this case (Hoek and Bray, 1991). Local unstable areas where the safety factor approaches equilibrium are evident in many quarries (Plate 2.5). These unstable areas are commonly small in size and temporary in nature. They are primarily a result of operational pit configurations and usually do not represent the quarry or design area as a whole. Failures of these types of slopes are usually avoidable by small changes in the mine plan.

Design of slopes that support mining structures requires safety factors higher than those in active producing areas. A safety factor of 1.5 is preferred for critical slopes adjacent to important installations. Failure of a slope buttressing a preparation facility or a



Plate 2.5 - Unstable Slope in Active Producing Area

rail load-out can significantly incapacitate an operation. In the case of preparation plants, relatively small movements of the slope are sufficient to damage the alignment of processing machinery. Lateral movements of railroad car sidings can cause derailments and/or increase the time required to pull loaded cars and drop empty cars. The loss of a haulroad can temporarily bottleneck a quarry operation.

Design of the ultimate highwall requires the highest consideration of failure consequence, and the highest design safety factor is necessary to ensure long-term stability. Regulatory agencies in the northeast U.S. are now inquiring into the methods of justification for abandonment of quarries with vertical walls. This common practice of the past is coming under scrutiny as quarries plan for deeper development. The deeper development is a result of the depletion of reserves and the difficulty of obtaining permits to mine new areas.

An example of a simplified design protocol for long-term stability of quarry highwalls is shown in Figure 2.9. This protocol recommends a safety factor of two (Haycocks et al., 1991). The assignment of safety factors to specific slopes for long-term stability is difficult and discretionary. Consideration for long-term stability may include assumptions of zero cohesive strength and maximum hydraulic pressures. These limitations suggest that long-term stability may be more appropriately evaluated by probabilistic methods.

### **2.8.3 Magnitude of Failure**

While the method of failure and the factor of safety of a given slope are indicators of stability, they do not address the relevance of scale or magnitude of a failure. In general, magnitude may be considered the volume of material produced by a failure. Plane failure of a discontinuity that is only a few degrees less than the inclination of the slope

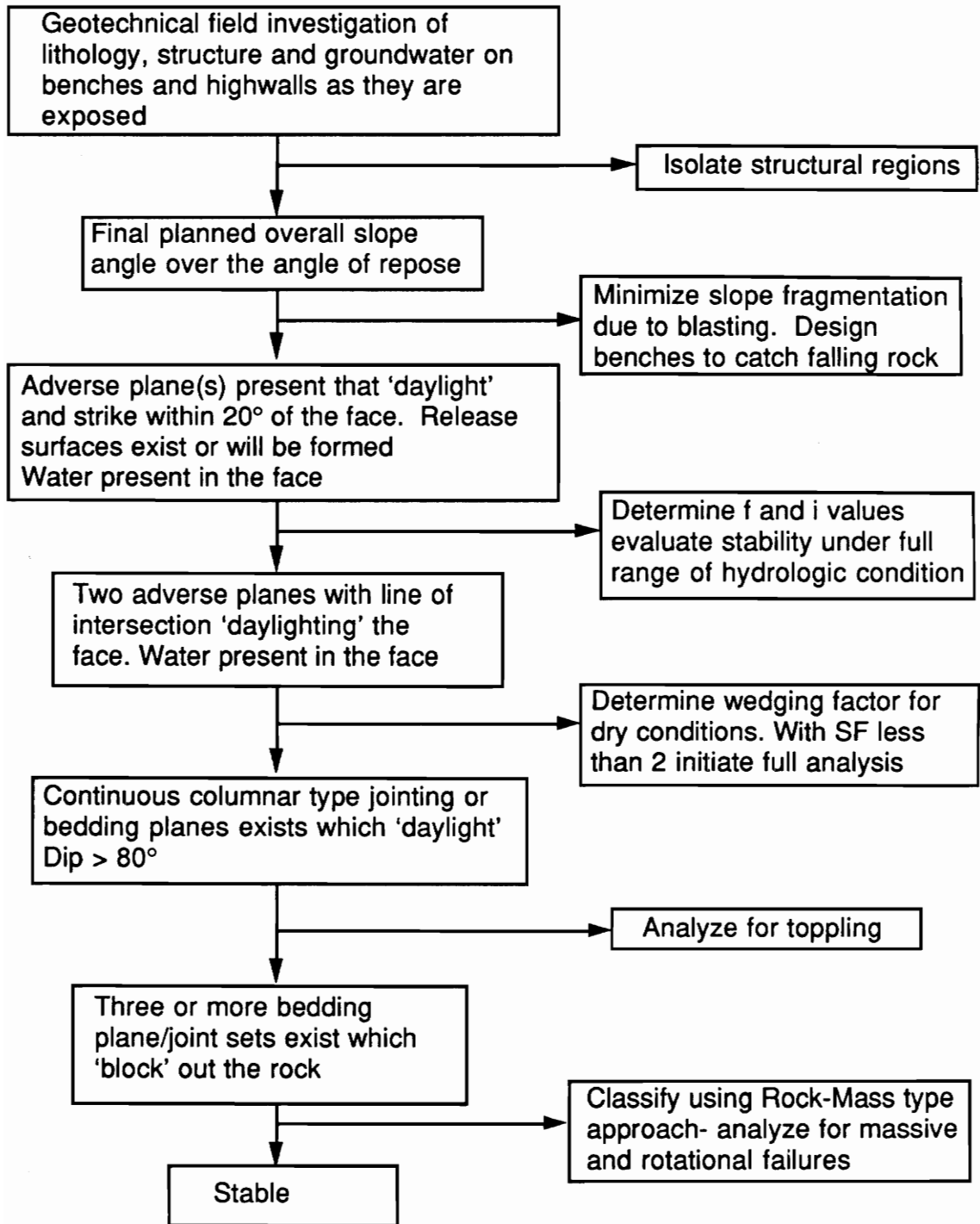

Figure 2.9 - Simplified Design Protocol for Highwall Stability  
(Haycocks et al., 1991)

may yield only a small volume of material when the height of the highwall is not excessive (Figure 2.10). The same may be true of a tight wedge with a plunge just less than the dip of the highwall. While failure may occur in both of these situations, the implications of the failure are not as significant as failure along a discontinuity that has half the angle of inclination of the highwall. Of course other considerations are necessary to evaluate the impact of a failure including location of structures and roads. In these cases even small failures may contribute large operating inconveniences.

## **2.9 Reliability in Stability**

Reliability in stability is a probabilistic evaluation based on the use of all available data. Probabilistic methods allow the minimization of uncertainty by including the variability of geotechnical parameters. Random numbers generators, applying various sampling techniques, are used to obtain data sets for stability calculations. Calculating stability a very large number of times assures that all data is incorporated into the analysis. Case studies allow comparisons of the reliability values.

### **2.9.1 Probabilistic Methods**

In recent years there has been an increasing interest in probabilistic approaches to geomechanical problems (CANMET, 1977 ; Fraher, 1992), and risk studies within a probabilistic framework have gained acceptance as supplements to conventional deterministic methods of analysis (Haycocks, 1992). Deterministic analyses evaluate stability based on single value estimates of parameters that are often subjectively chosen. Conversely, calculation of the probability of reliability in slope stability takes into consideration not only expected values of the parameters but also the dispersion of those values.

In the most general sense, probabilistic methods account for the uncertainty and variability of material properties and loads on a rational basis. Uncertainty exists because of unknown and partially known conditions in a slope. In nature, uncertainty encompasses all geotechnical parameters. No parameter can be absolutely known to perfectly represent a given situation, and not all sources of uncertainty can be identified in advance of mining (Chowdhury, 1986).

Variability in geology includes rock strength, residual tectonic stress, and discontinuity orientation. Rock strength is known to vary from 30,000 psi for unaltered intact rock to less than 100 psi for a gouge zone less than a foot away. In-situ stress is difficult and expensive to obtain and has been shown to vary significantly from values calculated for overburden load. Measured stress is known to vary widely in orientation and magnitude (Coates and Grant, 1966). Discontinuities measured in a quarry are subject to both natural and man-made variations. The orientation and inclination of a discontinuity can be expected to change laterally over very short distances as its position relative to a structural feature, such as a fold or fault, changes. Human measurement differences of discontinuities with a Brunton compass may also contribute to dispersion of the dip direction and dip magnitude.

Statistical analysis of the geotechnical problems allows quantification of all data. However, certain statistical assumptions are necessary in order to develop probabilities of stability, and these assumptions introduce additional uncertainty. A common assumption of geomechanical probability is that the rock mass is statistically stationary. This assumption implies that the statistical values of any parameter of the rock mass are the same at any point within the region of interest and that they do not spatially change. Spatial variability of significant parameters in soil and rock slopes has been studied (Azunbung, 1961 and Vanmarke, 1977), and the value of spatial variability has been

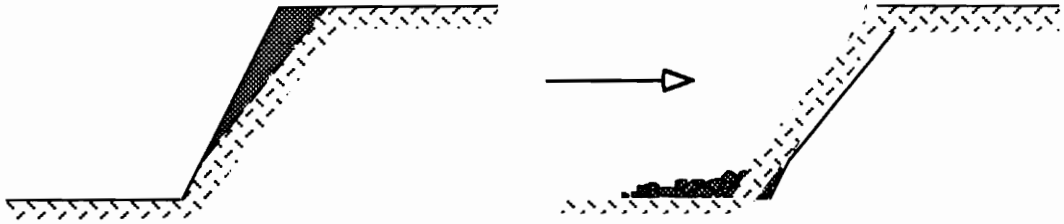

Failure where the angle between the discontinuity and face is small.

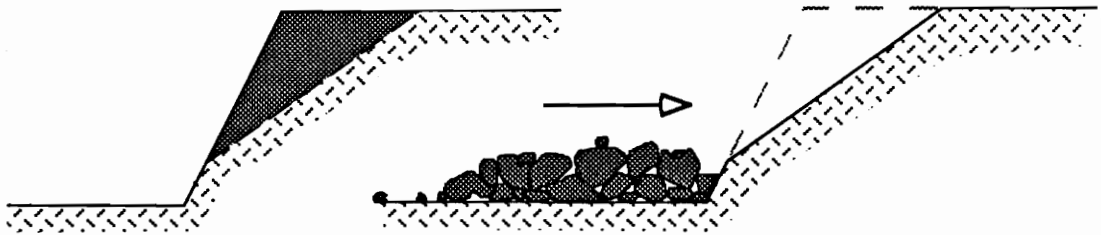

Failure where the angle between the slope and the discontinuity is large.

Figure 2.10 - Volume Produced By Failure of Differing Discontinuity Inclinations

demonstrated (Vanmarke, 1977 and Chowdhury, 1980). Another assumption that increases uncertainty is the selection of the distribution that fits the data. The gaussian, triangular, truncated gaussian, exponential, and uniform distributions have each been used in probability analysis of slope stability (CANMET, 1977).

Typical probability analysis calculates the factor of safety a large number of times using parameters derived from the data by a variety of methods. These methods include selection of a real data set from the total population of data, generation of an artificial data set from a cumulative distribution curve developed from the total population of data, and generation of an artificial data set from statistics of the total population of data. The mean and standard deviation are the most common statistics employed. Selection of a distribution that represents the data is also necessary when developing a data set with statistics (CANMET, 1977).

A random numbers generator is usually used to obtain the sample set. Various sampling methods, including Monte Carlo, Latin Hypercube, and Generalized Point Estimate Method (GPEM), have met with considerable success in ground control design (Pine et al., 1992).

Another probabilistic method of estimating stability independently calculates resisting/disturbing forces. With this method, a distribution is assigned to each set of forces, and the probability of instability is determined as the area of overlap between the two probability density curves. A variation to this method evaluates the distribution of safety margins where the safety margin is defined as the difference between resisting and sliding forces. A distribution is selected for the safety margins, and the area of negative values under the probability density curve represents the probability of failure (McCracken, 1983).

In the probabilistic equilibrium approach, each safety factor calculation is treated as a random variable. Safety factor calculations involving more than one combination of discontinuities may or may not be regarded as independent random variables, and correlation of safety factors between pairs of discontinuities may be necessary to confidently assure independence (Chowdhury, 1987).

### **2.9.2 Interpretation of Reliability**

Case studies of rock slopes in South Africa have allowed comparisons of the significance of probabilistic stability. These studies suggest that reliability in stability of greater than 70% represents "acceptable" operating conditions provided "strict monitoring procedures are adopted" (Steffen, 1982). Where reliability in stability is greater than 85%, "only superficial monitoring" is required (Table 2.5). In mines where long-term stability is critical and/or where the public has limited access, reliability in stability of 98.5% is recommended. For very long-term stability where public access is unlimited, the acceptable reliability in stability is increased to 99.5% (Kirsten, 1983).

Table 2.5 - Relative Significance of Reliability  
(after McCracken, 1983)

Operation	Stand-up time	Reliability	Monitoring requirements
permanent civil works free public access	very long	< 99.5	none
civil works public access restricted	long	98.5 - 99.5	incidental observations
small open pit/ quarry final slopes	medium long	96.0 - 98.5	superficial monitoring only
large open pit final slope	medium	85.0 - 98.5	superficial monitoring
small open pit/ quarry final slopes	medium	85.0 - 98.5	regular simple monitoring
large open pits final slopes	short	70.0 - 85.0	continuous sophisticated monitoring
temporary benches, slopes	very short	50.0 - 70.0	not generally required
	zero	< 50.0	serves no function

## **CHAPTER III. - SOFTWARE DEVELOPMENT**

### **3.1 Identification of Failure Mechanisms**

On-site evaluation of 15 carbonate quarries in Virginia and Maryland revealed that plane failure and wedge failure are the predominant mechanisms of slope instability in these types of mines. Discontinuities were determined to be the most influential component of plane and wedge stability. The orientation of discontinuities can determine whether a rock mass will remain in place or whether portions of it are free to slide. Failure was determined to occur along a single plane or in a combination of planes as in a wedge.

While the potential for rotational failure exists in very strong rocks when they are highly fragmented relative to slope height, high estimates of rock mass integrity based on the Rock Mass Rating (RMR) system and conversations with mine personnel suggested that this was not a potential failure mechanism in these mines. Raveling failure was identified at nearly all of the quarries visited. However, the volume of material generated by raveling was rather insignificant, and this mode was eliminated as a potential mechanism of large-scale failure. None of the quarries exhibited toppling failure. High RMR ratings and conversations with mine personnel suggested that toppling was not a potential failure mode.

### **3.2 Development of PSLOPE**

The software package "Pit Slope Optimization Evaluation" (PSLOPE) was developed to facilitate evaluations of 'Plane Stability', 'Wedge Stability', 'Reliability in Plane Stability', and 'Reliability in Wedge Stability' for rock slopes. A flow chart of PSLOPE is shown in Figure 3.1. PSLOPE incorporates all the basic design components

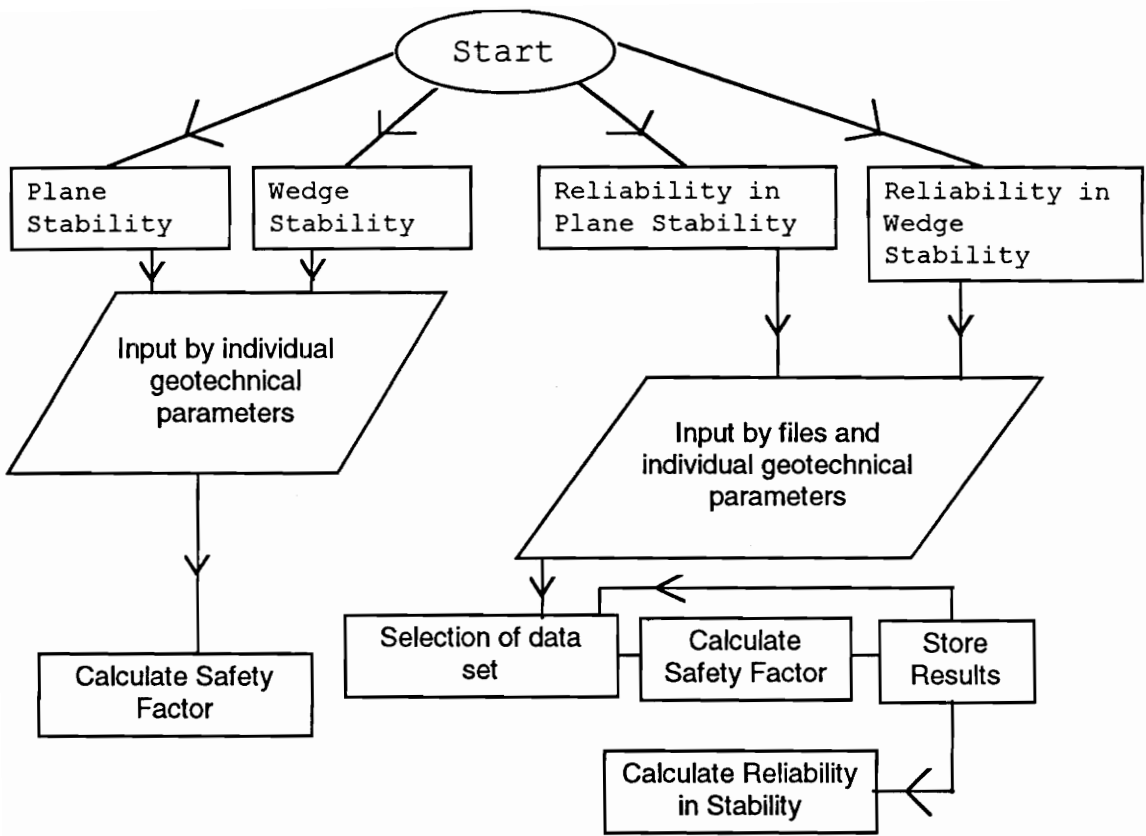

Figure 3.1 - Simplified PSLOPE Flowchart

of slope stability and allows for safety factor calculations, reliability estimations, back-analysis, and sensitivity studies. Also included for reference are ranges of physical properties such as angles of internal friction and cohesion for specified lithologic units obtained from published slope stability cases.

### **3.3 Hardware Requirements**

PSLOPE is a graphical user interface application written in Visual Basic, a programming language developed by Microsoft Corporation. The application requires at least an IBM compatible personal computer with an 80286 processor on which "Windows" has been installed, one megabyte of random access memory, and a mouse. PSLOPE will operate only in a Microsoft "Windows" environment. The application consists of a collection of stability analysis forms that use control boxes to input and control buttons to initiate action. The mouse is used to select the appropriate stability form and to move from control box to control box. It is also used to activate the control buttons that initiate computation, to retrieve the reference information, and to print the stability results. The keyboard is used to input data into the control boxes.

### **3.4 Software Components**

PSLOPE consists of a batch file holding an executable file and a run-time dynamic library link (dll) file. "Pslope.exe" is the executable file containing the program code for rock slope stability. "Vbrun100.dll" is the run-time file that permits PSLOPE to run on computers on which Visual Basic is not installed. Visual Basic is not required to run PSLOPE. Microsoft permits distribution of "vbrun100.dll" with "pslope.exe" but does not allow distribution of "vbrun100.dll" by itself. No additional license or payment to

Microsoft is necessary to distribute "vbrun100.dll" with "pslope.exe". Sample files are included in the batch file as examples.

### **3.5 Using PSLOPE**

Execution of the PSLOPE batch file through the File/Run "Windows" command initiates the program and loads the introductory form (Figure 3.2). The introductory form credits the Mining and Minerals Engineering Department of Virginia Tech for development of PSLOPE and contains control buttons for 'Editor', 'Help', and the four analytical stability forms: 'Plane Stability', 'Wedge Stability', 'Reliability in Plane Stability', and 'Reliability in Wedge Stability'. The stability form for the option of interest is obtained by selecting the appropriate control button with the mouse. The 'Help' screen retrieved from the introductory form explains the use of the mouse in navigation through PSLOPE. This screen also addresses the use of other 'Help' screens, units of input, and how to 'Quit' the application as shown in Figure 3.3.

### **3.6 Input of Geotechnical Data**

Input into PSLOPE is from the keyboard or from files stored on a hard drive or floppy disk. Any rational units may be used as input. U.S. units are included on the stability forms only for reference. All angles must always be input in degrees. Included in the stability code is error checking designed to prevent input of unrealistic data. The error checking code of PSLOPE causes a warning message box specific to the input parameter in question to "pop-up" on the computer screen as shown in Figure 3.4. Stability computation is suspended with the warning message. Selecting the "OK" control button on the error message box returns the focus of control to the stability form on which the questionable data was placed. Examples of unrealistic data include dip directions greater

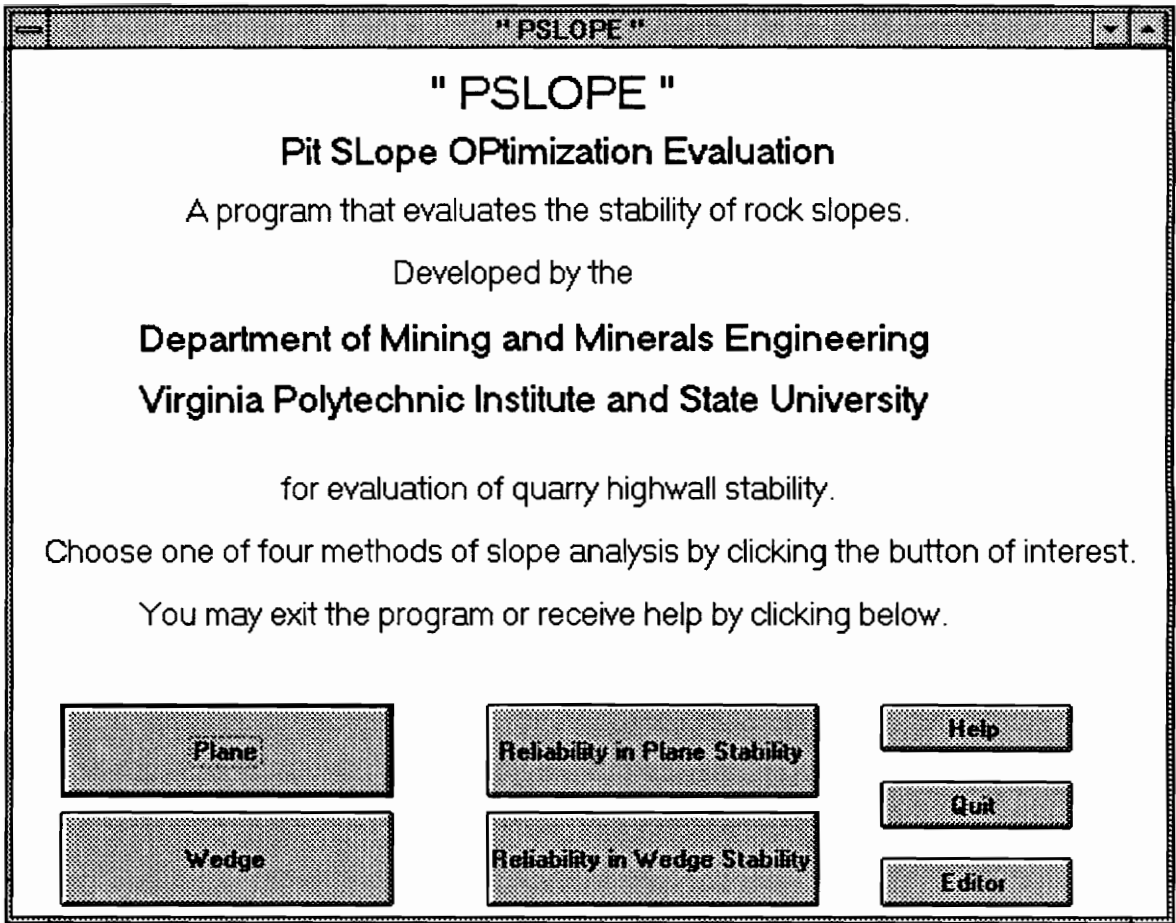

Figure 3.2 - Introductory Form of PSLOPE

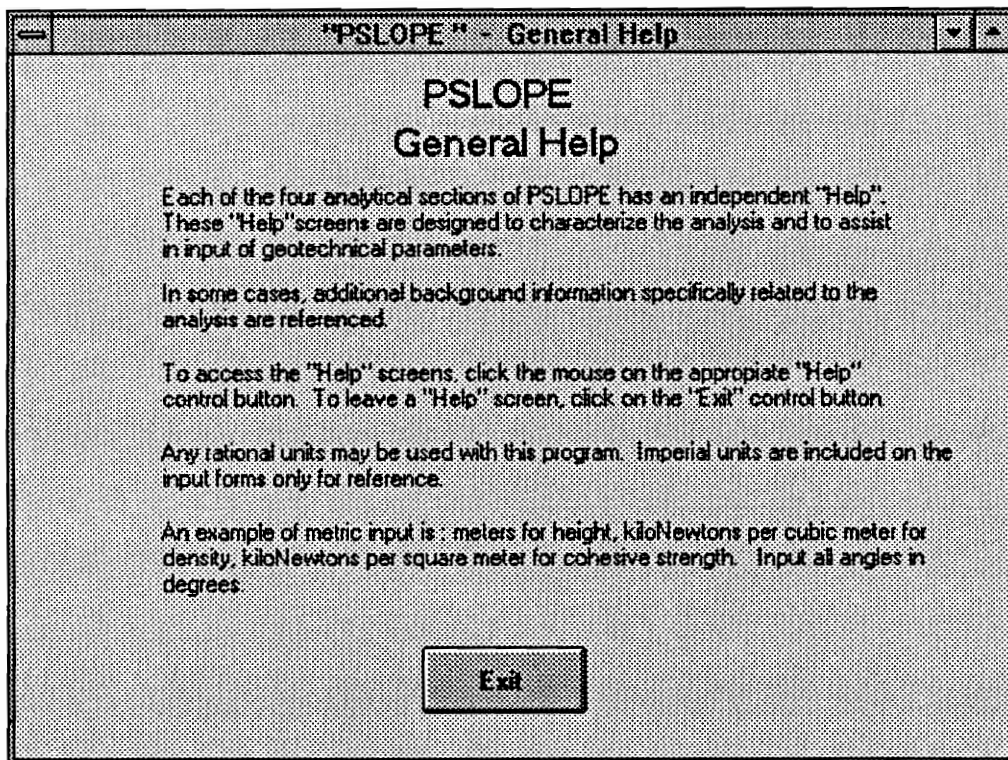

Figure 3.3 - 'General Help' Screen

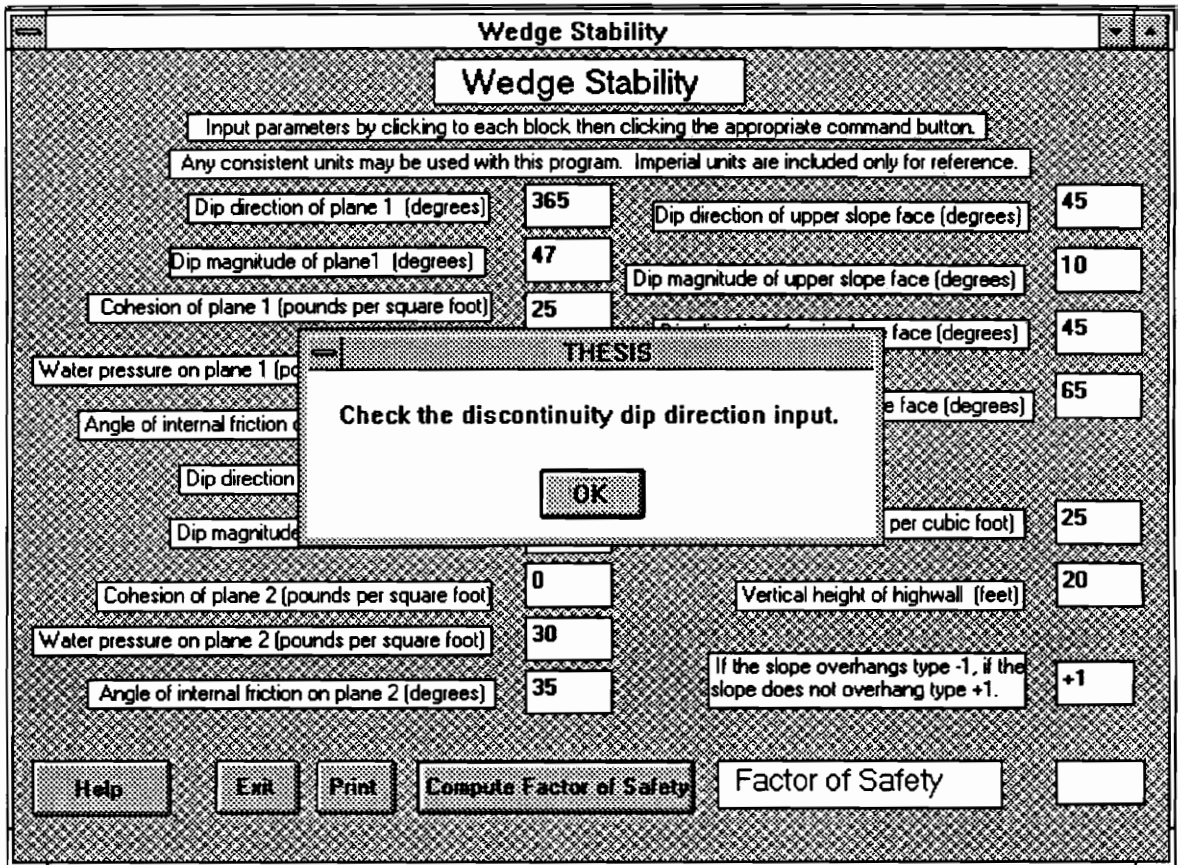

Figure 3.4 - Example of Error Checking by PSLOPE

Note: Input of dip direction is greater than 360 degrees.

than 360 degrees or less than zero and cohesions that are less than zero. The program code also contains instructions to signal with an error message box when the friction angle input is greater than 70 degrees. The error checking routines of PSLOPE apply only to the 'Plane Stability' and 'Wedge Stability' options. No input error checking is provided for in the 'Reliability in Plane Stability' and the 'Reliability in Wedge Stability' options. Care must be taken in the accurate construction of the cohesion, friction angle, and discontinuity files necessary to run these stability options. The 'Editor' included within the program allows construction, retrieval, modification, and renaming of files within PSLOPE. Selecting the 'Editor' control button on the introductory form opens the 'Editor' as shown in Figure 3.5. The 'Editor' allows the user to modify existing files and to construct new files. The files that store the geotechnical data for use in the reliability analysis must be sequential and may be separated by commas or spaces. Files for reliability evaluation may also be created in any other text editor.

### **3.7 Availability of 'Help'**

Help is instantly available in all sections of the program by selecting 'Help' control buttons. The 'Help' forms explain limiting equilibrium, describe the general conditions of failure, and define the concepts of a safety factor and reliability. They also define the assumptions of the analysis and give access to geotechnical parameters from published slope stability papers (Figure 3.6 through Figure 3.13). Particularly helpful is the catalog of published case studies that provide referenced geotechnical data. The data is referenced by title, author, and publication source so that more complete information on the 'Help' subject may be obtained from the original paper. 'Help' is available within each stability analysis option.

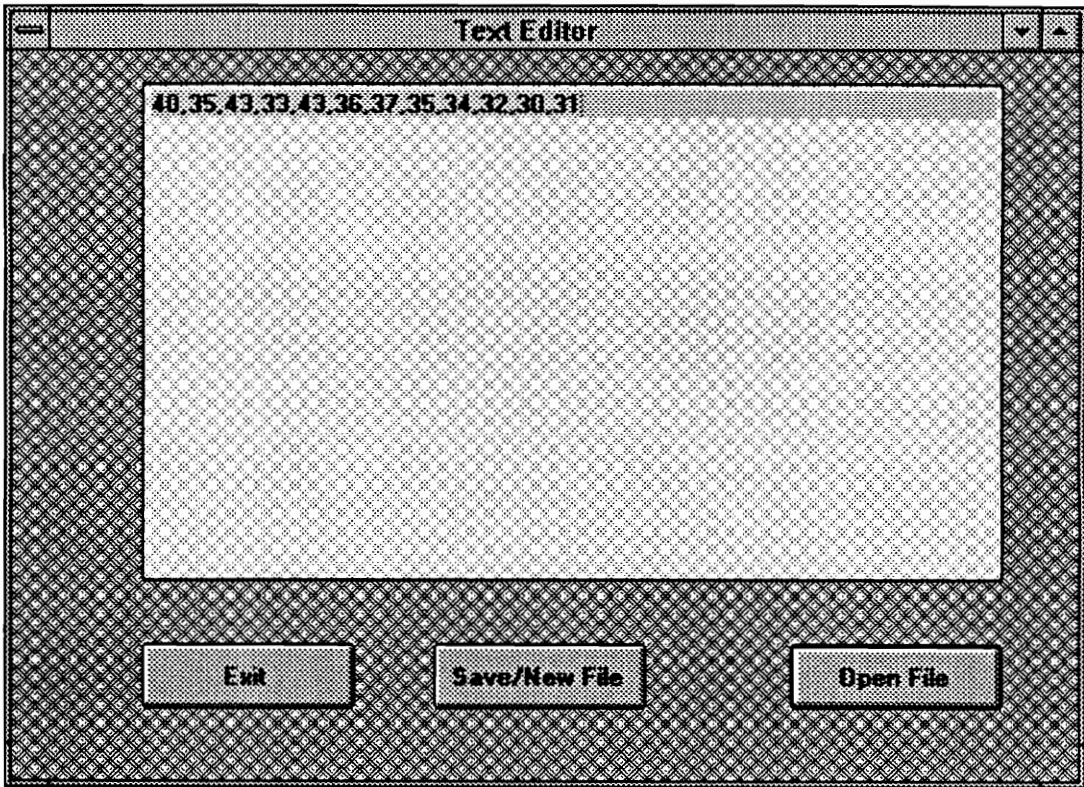

Figure 3.5 - PSLOPE 'Editor' Screen

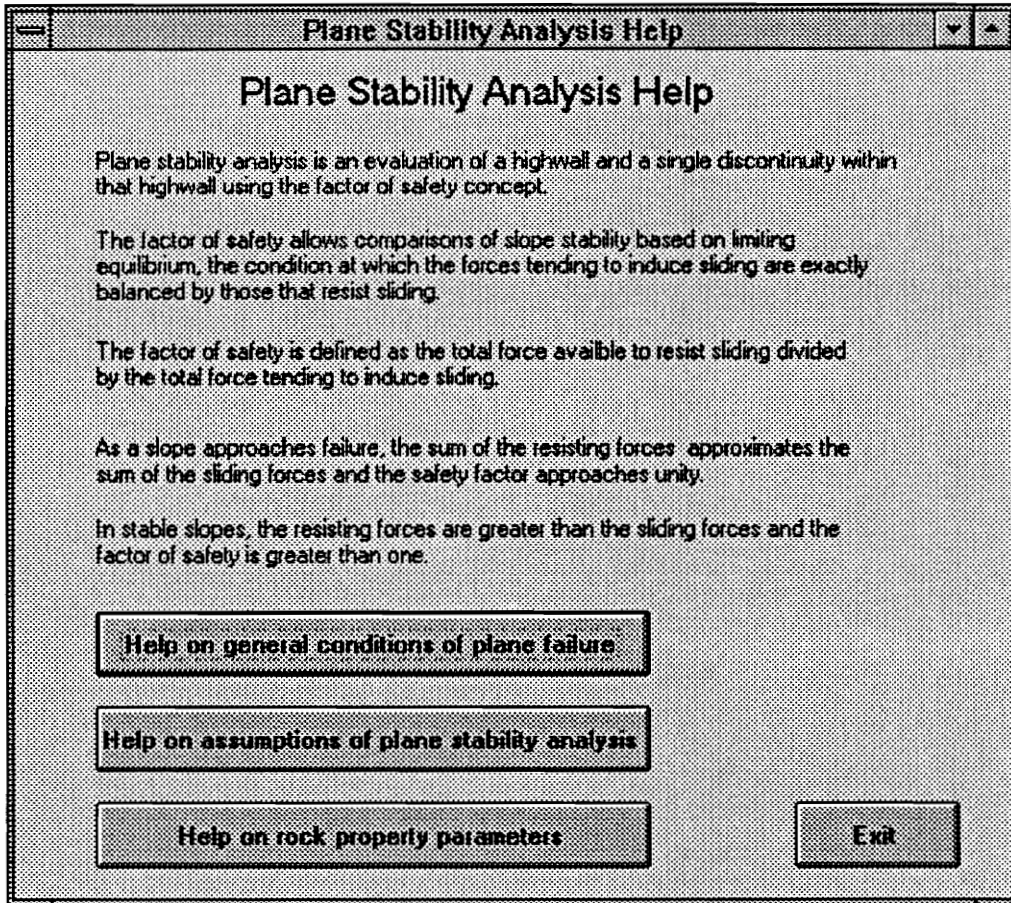

Figure 3.6 - 'Plane Stability' Analysis Help Screen

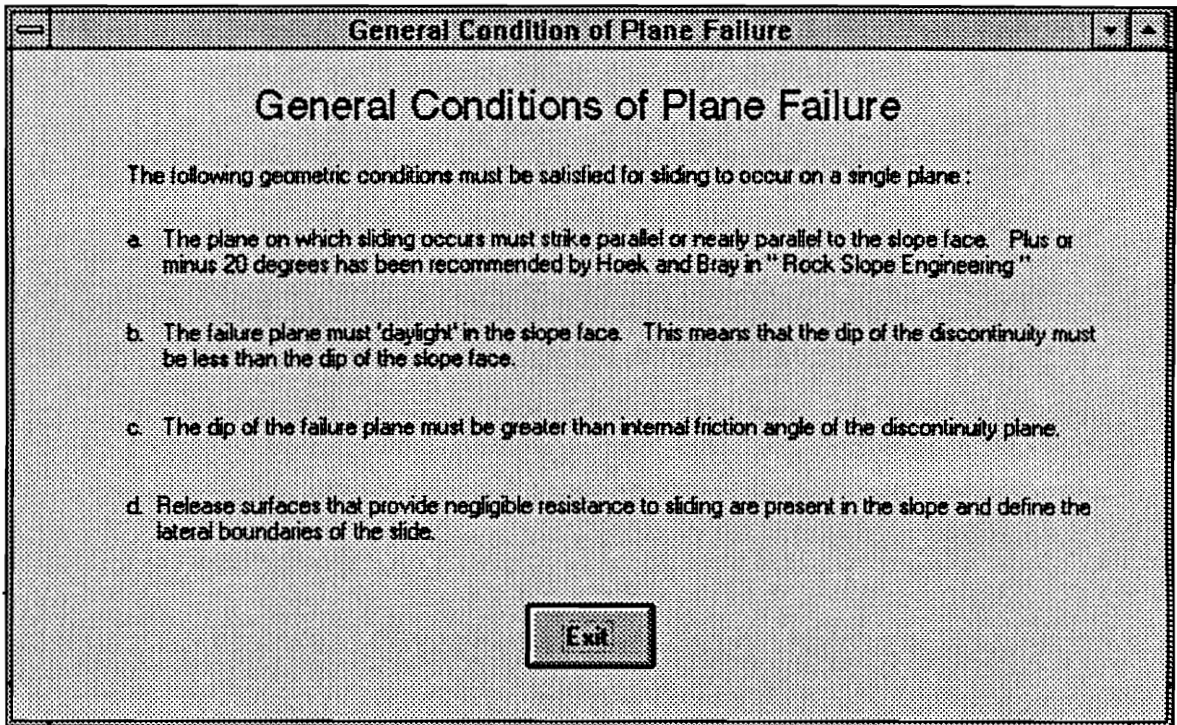

Figure 3.7 - General Conditions of Plane Failure Screen

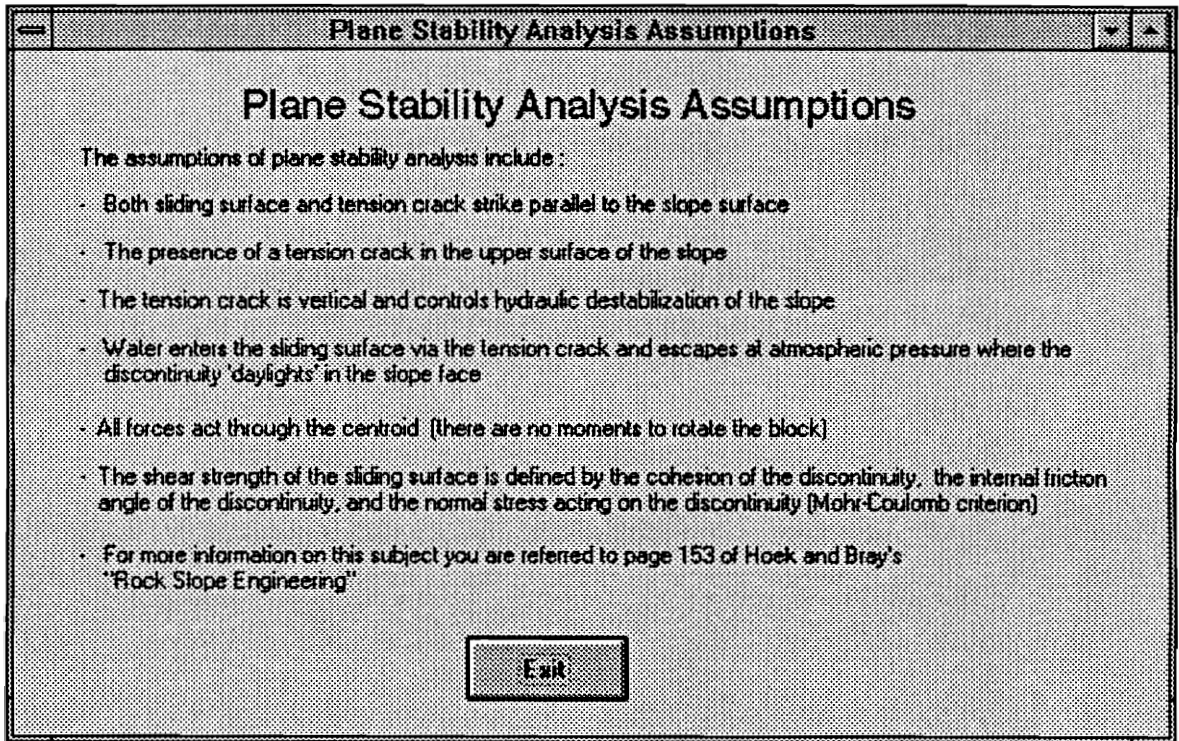

Figure 3.8 - Plane Stability Analysis Assumptions Screen

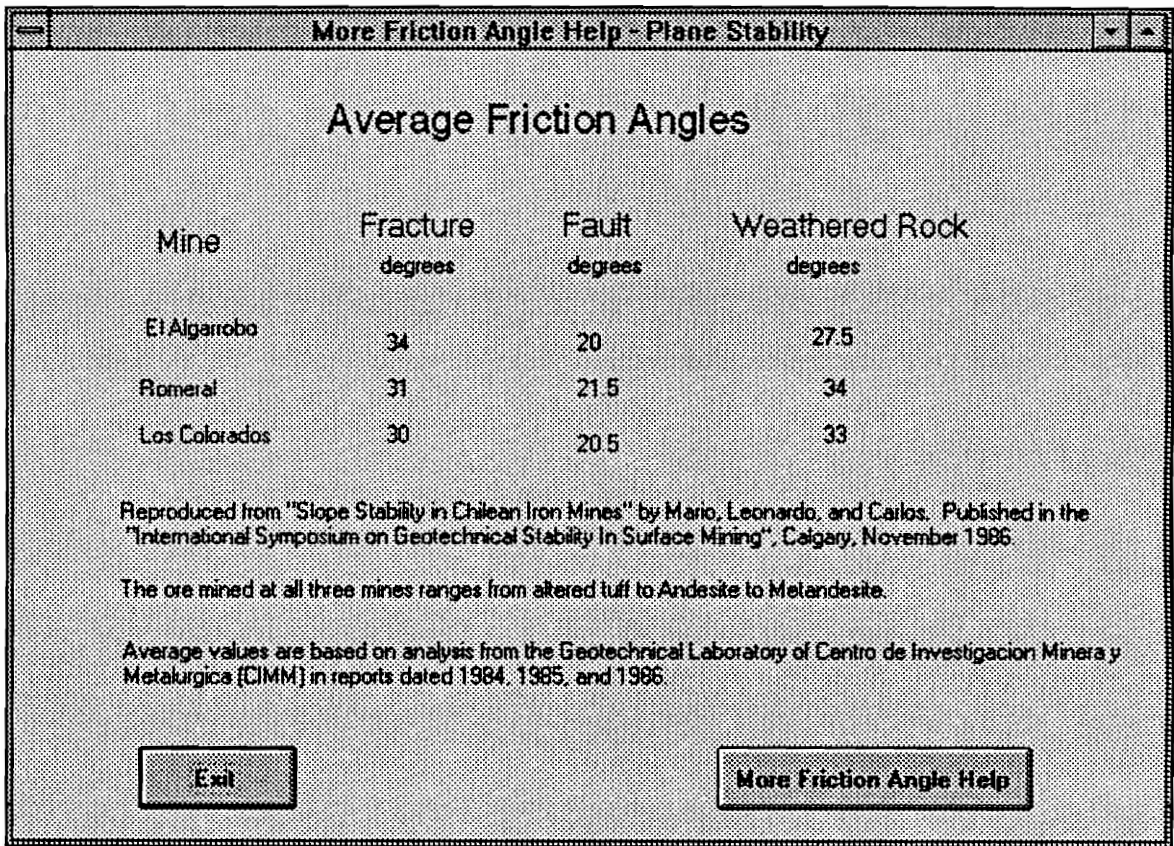

Figure 3.9 - Example of Friction Angle Help Screen

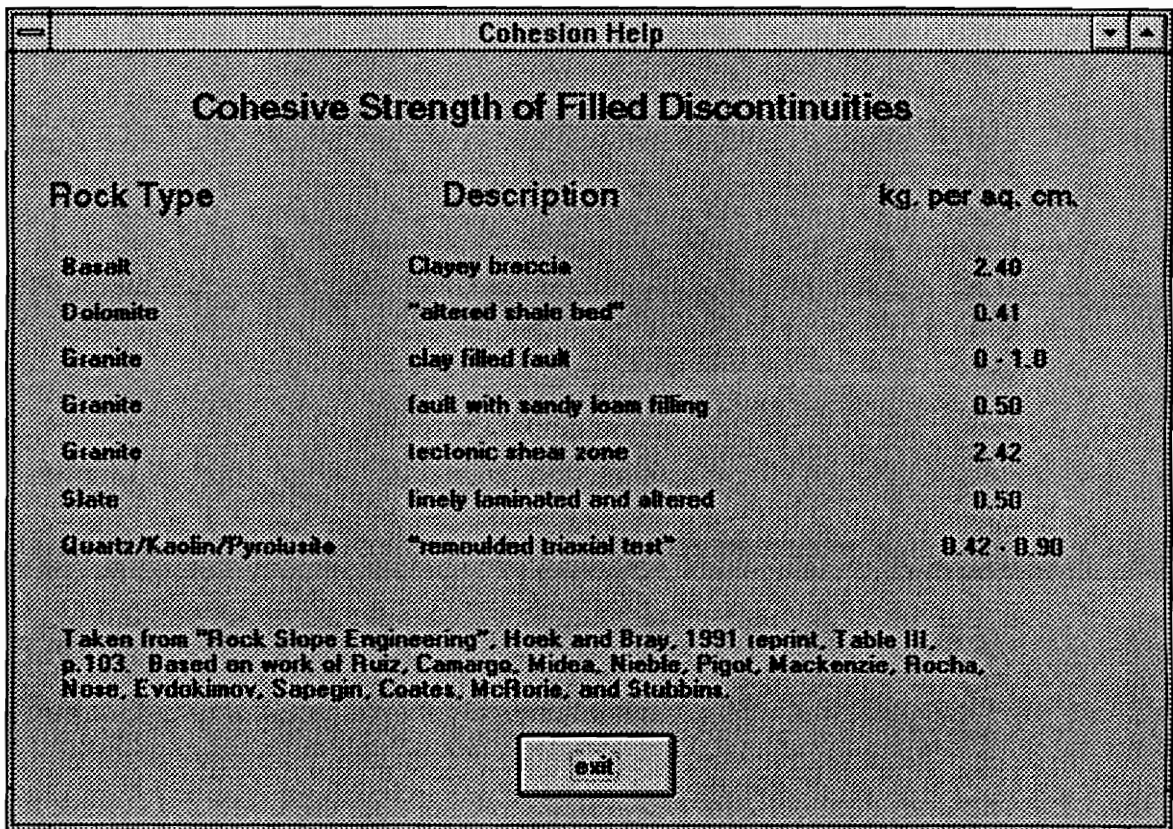

Figure 3.10 - Example of Cohesion Help Screen

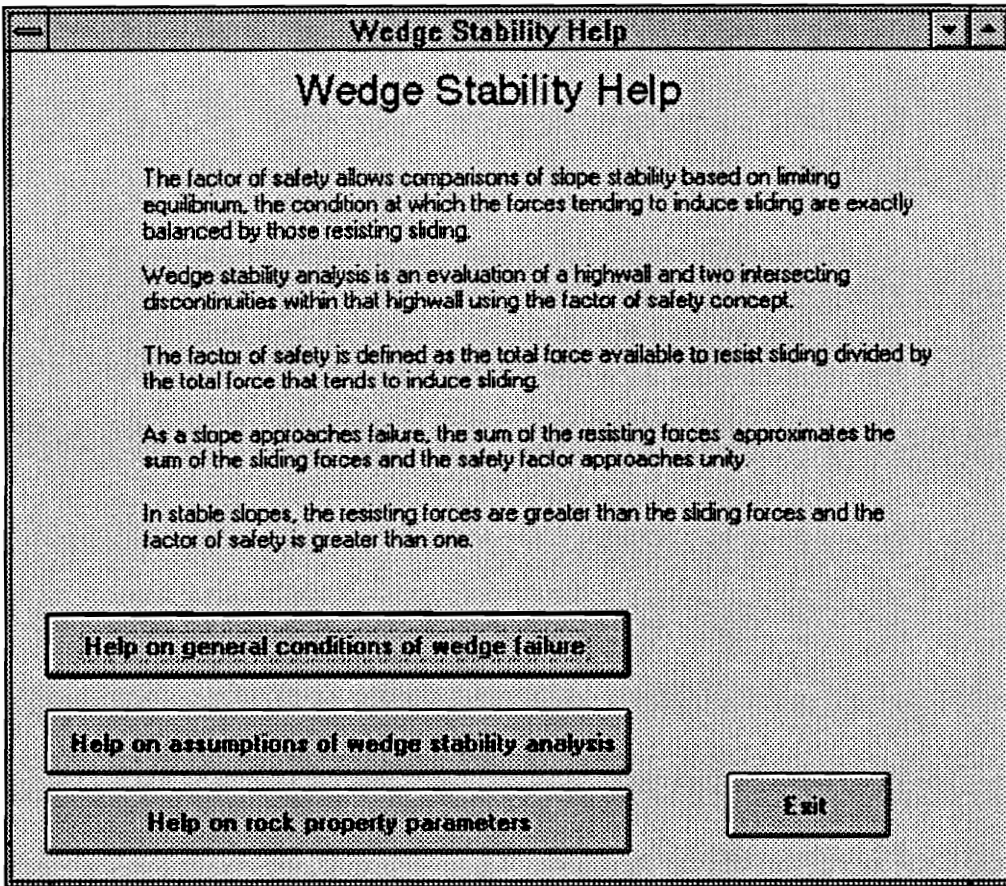

Figure 3.11 - 'Wedge Stability' Help Screen

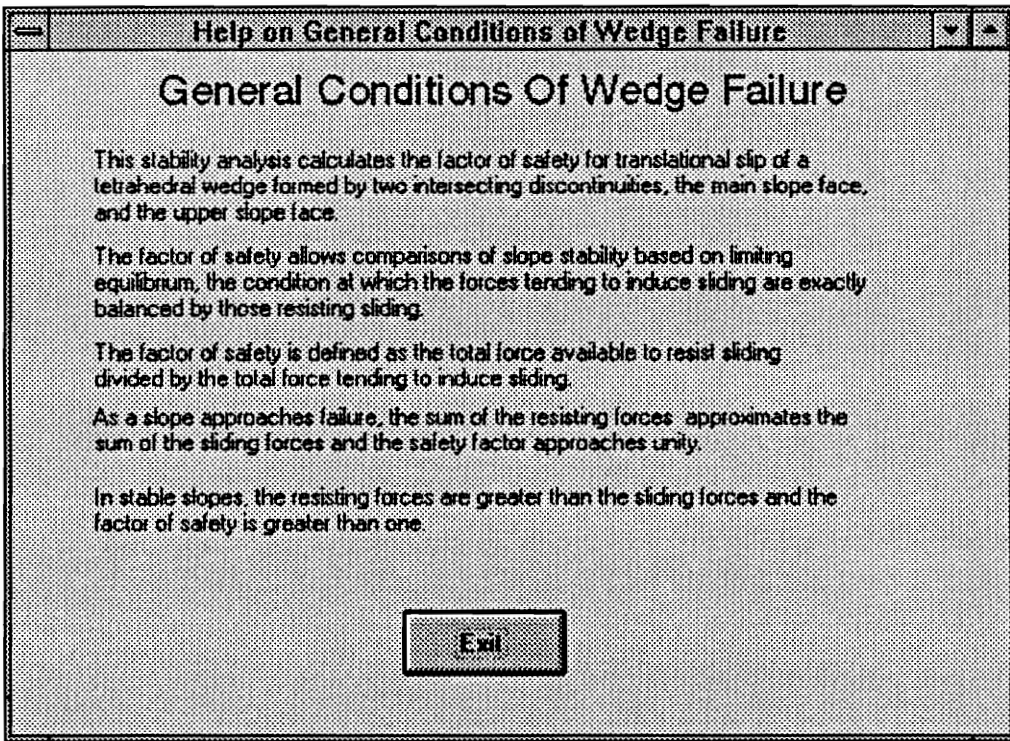

Figure 3.12 - General Conditions of Wedge Failure Screen

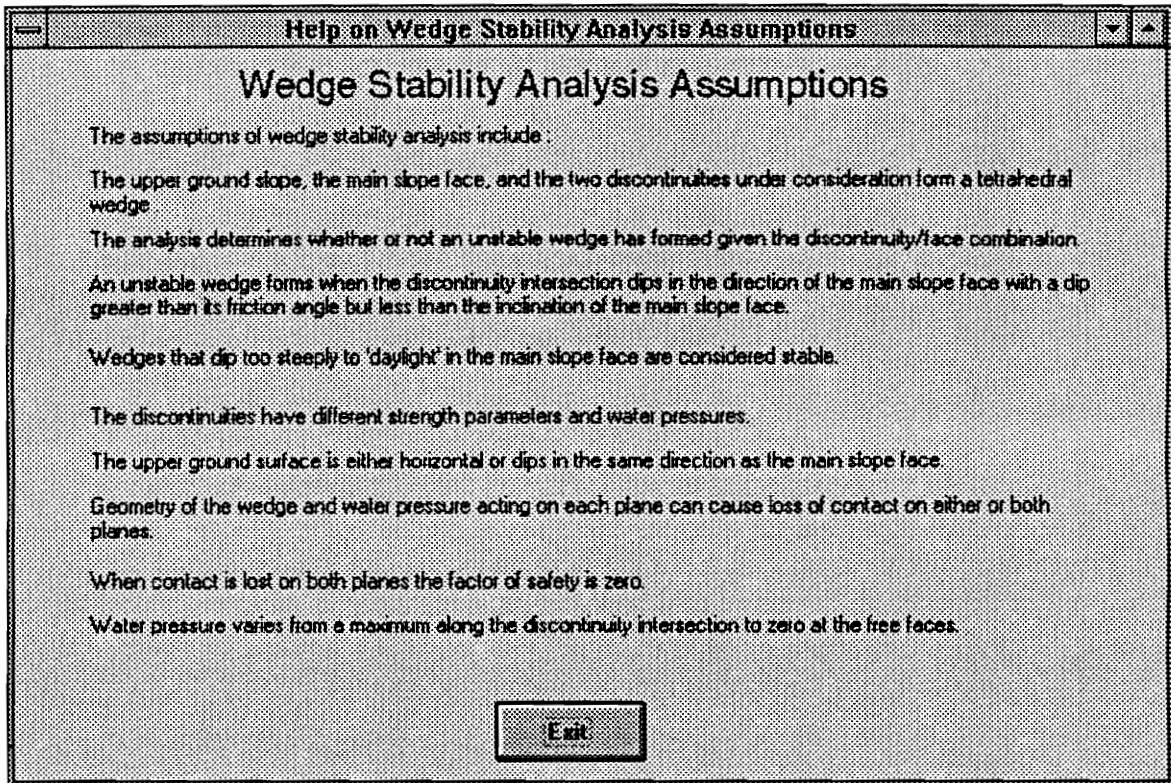

Figure 3.13 - Wedge Stability Analysis Help Screen

### **3.8 Safety Factors from 'Plane Stability' and 'Wedge Stability'**

Safety factors are obtained from the 'Plane Stability' and 'Wedge Stability' forms by inputting individual geotechnical and slope geometry parameters into control boxes and then selecting the 'Compute' control button with the mouse (Figure 3.14). The 'Plane Stability' option assumes that a tension crack is located on the upper slope face.

Other control buttons on these forms allow the user to get 'Help', 'Print', and 'Exit'. Selecting the various 'Help' and 'Exit' buttons with the mouse allows the user to move through this information. Selecting the 'Print' button after the 'Compute' button delivers a hard copy of the form with the input information and computation results. Selecting the 'Exit' buttons ultimately brings the user back to the introductory form. PSLOPE may be terminated by selecting the 'Quit' button on the introductory form.

### **3.9 Investigation to Determine Possibility of Failure in 'Wedge Stability'**

The 'Wedge Stability' option of PSLOPE investigates the geometric relationship of all discontinuity and slope orientations to determine the possibility of wedge failure. The error checking code of PSLOPE causes the message box shown in Figure 3.15 to "pop-up" on the computer screen when an unstable wedge does not form. Selecting the "OK" control button on the message box returns the focus of control to the stability form.

For wedge failure to occur, the dip of the intersection of the two planes must be less than the dip of the slope so that it 'daylights' on the slope face, and the dip of the intersection must be greater than the friction angle, including any aspirates. Further, the direction of intersection plunge must be within plus and minus 90 degrees of the direction of the slope dip. PSLOPE does not check for the relationship between the discontinuity and the slope under the 'Plane Stability' option. Care must be taken in 'Plane Stability' to ensure that the discontinuity strikes within plus and minus 20 degrees of the slope face.

**Plane Stability**

**Plane Stability**

Input parameters by clicking to each block then click the appropriate command button.

Any consistent units may be used with this program. Imperial units are included only for reference.

Cohesion (pounds per square foot)	<input type="text"/>
Face angle of highwall (degrees)	<input type="text"/>
Vertical height of highwall (feet)	<input type="text"/>
Dip of discontinuity (degrees)	<input type="text"/>
Distance from face to tension crack (feet)	<input type="text"/>
Portion of tension crack filled with water (percent)	<input type="text"/>
Angle of internal friction of discontinuity (degrees)	<input type="text"/>
Density of rock (pounds per cubic foot)	<input type="text"/>
Density of water (pounds per cubic foot)	<input type="text"/>

Figure 3.14 - 'Plane Stability' Screen Prior to Data Input

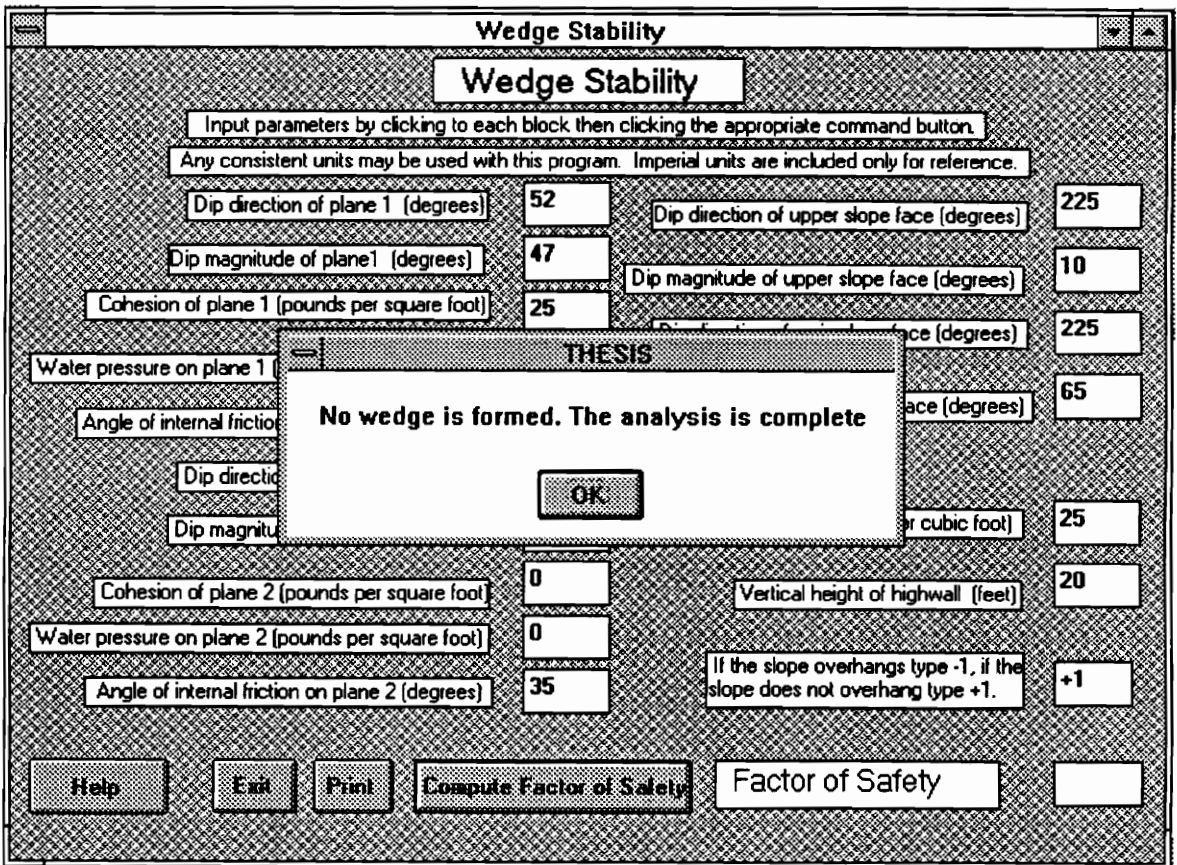

Figure 3.15 - Message Box Indicating Input Does Not Form Unstable Wedge

### **3.10 'Reliability in Plane Stability' and 'Reliability in Wedge Stability'**

Reliability is obtained from the 'Reliability in Plane Stability' and the 'Reliability in Wedge Stability' forms. Reliability is determined as the percentage of safety factors in the simulation greater than the specified bench mark safety factor. The size of the simulation, the bench mark safety factor and sequential files containing the cohesion, friction angle, and discontinuity data are input on the form. Each safety factor of the simulation is determined from a real set of data selected by the random numbers generator. Other rock parameters including water pressure, rock/water density, and slope geometry data are input individually into control boxes on the forms. Stability is estimated by selecting the 'Compute Reliability' control button with the mouse. The 'Reliability in Wedge Stability' option also returns information on whether or not contact is maintained on the discontinuity planes, and whether or not an unstable wedge formed. Values reported include the number of times contact was lost on both planes, the number of times contact was maintained on plane one, the number of times contact was maintained on plane two, and the number of times contact was maintained on both planes.

The 'Help' form defines reliability and provides directions for construction of sequential input files as shown in Figure 3.16 and Figure 3.17. This 'Help' form also defines the general conditions of failure and describes the assumptions of analysis. All of the 'Help' screens in 'Plane Stability' and 'Wedge Stability' also apply to the reliability options. Selecting the 'Help' buttons and the 'Exit' buttons with the mouse allows the user to move through this information. Selecting the 'Print' button after the 'Compute' button provides a hard copy of the form by sending that command to the printer. Selecting the 'Exit' buttons ultimately brings the user back to the introductory form. PSLOPE may be terminated by selecting the 'Quit' button on the introductory form.

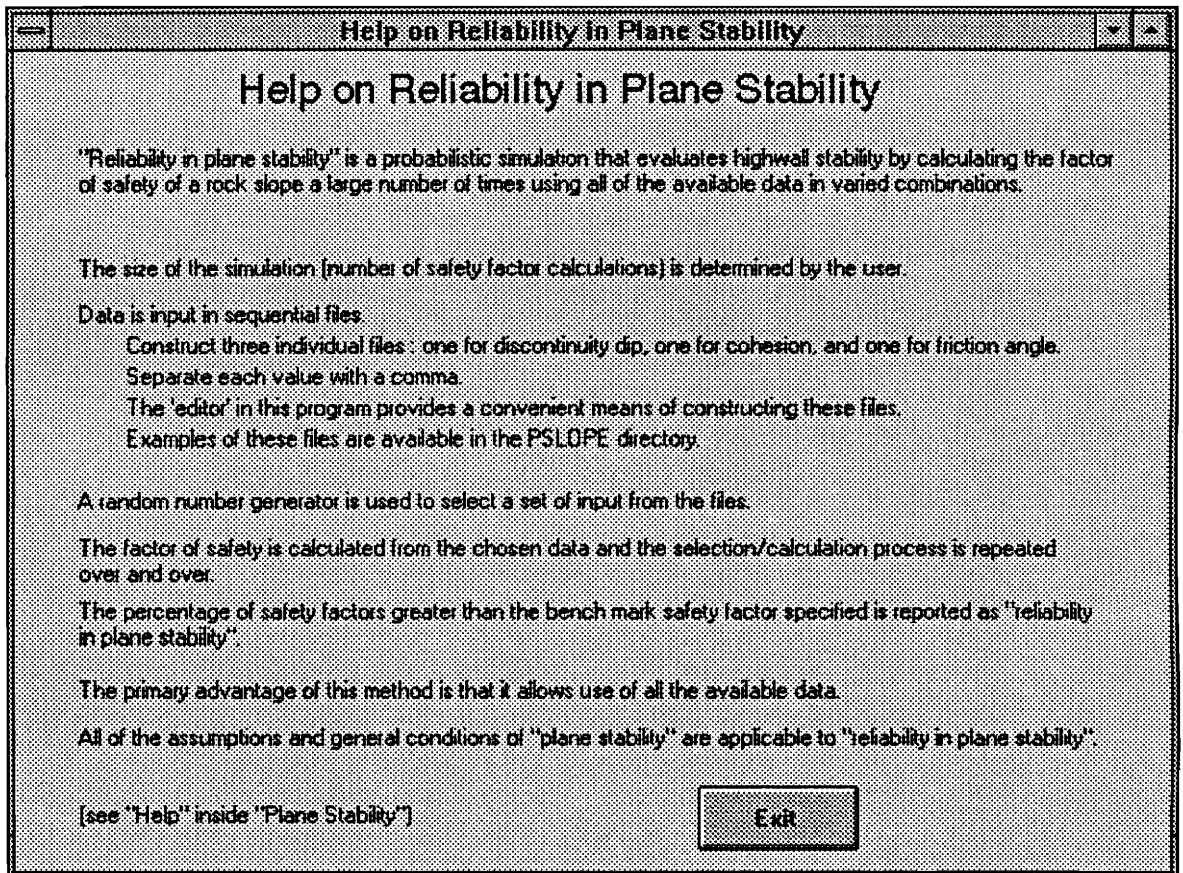

Figure 3.16 - Help on 'Reliability in Plane Stability' Screen

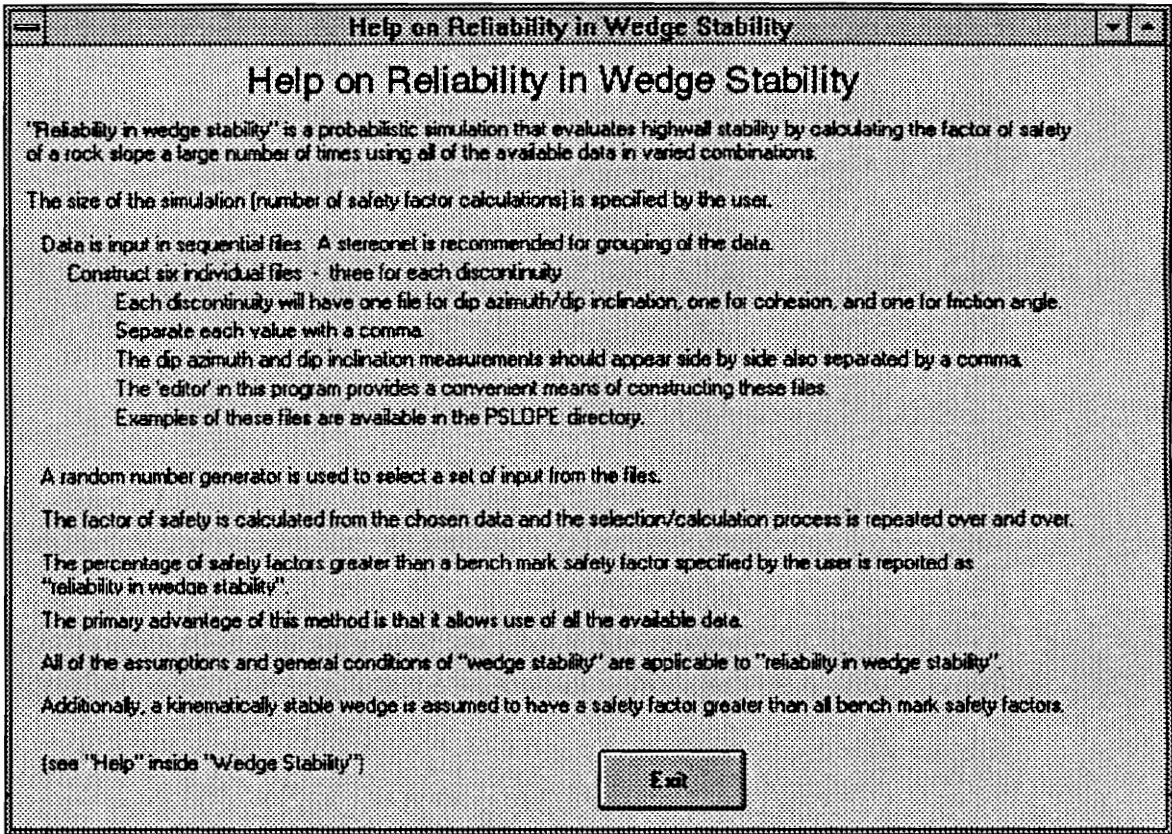

Figure 3.17 - Help on 'Reliability in Wedge Stability' Screen

### **3.11 Evaluation of Ultimate and Bench Slope Angles**

PSLOPE may be used to evaluate both ultimate highwall slope angles and bench slope angles as shown in Figure 3.18. Bench slope angles are evaluated by input of slope geometry data specific to the bench under consideration. Ultimate highwall slope angles may be evaluated by input of data specific to final pit configurations.

### **3.12 Program Validation**

As a demonstration of PSLOPE's accuracy and as an example of its use, case studies of plane and wedge stability were recalculated.

Plane stability is determined for the case of a 100-foot high slope with a 60-degree face angle and a bedding plane discontinuity that dips 30 degrees. In this problem, a tension crack is located 29 feet behind the crest and is determined to have a depth of 50 feet. Assuming that the rock of the slope has a density of 160 pounds per cubic foot, that the density of water is 62.5 pounds per cubic foot, that the cohesive strength of the discontinuity is 1000 pounds per cubic foot, and that the friction angle is 30 degrees, safety factors of 0.77 and 1.34 are found for saturated and dry conditions, respectively (Hoek and Bray, 1991). PSLOPE's 'Plane Stability' option returns safety factors of 0.78 and 1.35 as shown in Figure 3.19 and Figure 3.20. The difference in these values is the result of rounding.

Wedge stability is determined for the case of two intersecting discontinuities. Input for this problem is lengthy and is best shown in Table 3.1. In this problem, safety factors of 0.626 and 1.154 are computed for saturated and dry conditions (Hoek and Bray, 1991). PSLOPE's 'Wedge Stability' option returns values of 0.63 and 1.15 as shown in Figure 3.21 and Figure 3.22. The differences are attributed to rounding. Note that in this case

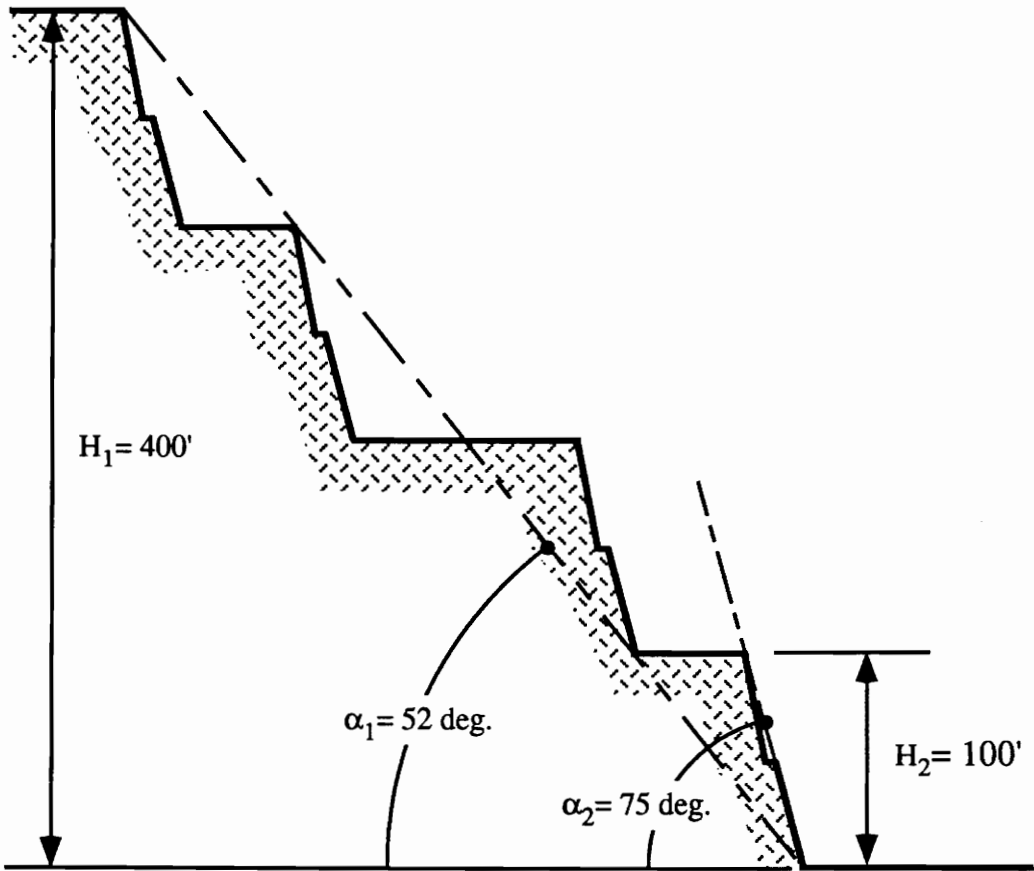

Figure 3.18 - Ultimate Slope Angle Versus Bench Slope Angle

**Plane Stability**

**Plane Stability**

Input parameters by clicking to each block then click the appropriate command button.

Any consistent units may be used with this program. Imperial units are included only for reference.

Cohesion (pounds per square foot)	1000
Face angle of highwall (degrees)	60
Vertical height of highwall (feet)	100
Dip of discontinuity (degrees)	30
Distance from face to tension crack (feet)	29
Portion of tension crack filled with water (percent)	0
Angle of internal friction of discontinuity (degrees)	30
Density of rock (pounds per cubic foot)	160
Density of water (pounds per cubic foot)	62.5

Factor of Safety 1.35

Figure 3.19 - Recalculation of Plane Stability Under Dry Conditions

**Plane Stability**

**Plane Stability**

Input parameters by clicking to each block then click the appropriate command button.

Any consistent units may be used with this program. Imperial units are included only for reference.

Cohesion (pounds per square foot)	1000
Face angle of highwall (degrees)	60
Vertical height of highwall (feet)	100
Dip of discontinuity (degrees)	30
Distance from face to tension crack (feet)	29
Portion of tension crack filled with water (percent)	100
Angle of internal friction of discontinuity (degrees)	30
Density of rock (pounds per cubic foot)	160
Density of water (pounds per cubic foot)	62.5

Factor of Safety	0.78
------------------	------

Figure 3.20 - Recalculation of Plane Stability Under Saturated Conditions

Table 3.1 - Input Data for Wedge Stability Recalculation  
(Hoek and Bray, 1991)

PLANE 1	
Dip direction (degrees)	52
Dip magnitude (degrees)	47
Cohesion (kN/m <sup>2</sup> )	25
Water pressure (kN/m <sup>2</sup> )	30
Angle of internal friction (degrees)	30
PLANE 2	
Dip direction (degrees)	18
Dip magnitude (degrees)	70
Cohesion (kN/m <sup>2</sup> )	0
Water pressure (kN/m <sup>2</sup> )	30
Angle of internal friction (degrees)	35
SLOPE GEOMETRY	
Dip direction of upper slope face (degrees)	45
Dip magnitude of upper slope face (degrees)	10
Dip direction of main slope face (degrees)	45
Dip magnitude of main slope face (degrees)	65
Density of rock (kN/m <sup>3</sup> )	20
Vertical height of highwall (meters)	20
If the slope overhangs type -1, if the slope does not overhang type +1.	+1

**Wedge Stability**

**Wedge Stability**

Input parameters by clicking to each block then clicking the appropriate command button.

Any consistent units may be used with this program. Imperial units are included only for reference.

Dip direction of plane 1 (degrees)	52	Dip direction of upper slope face (degrees)	45
Dip magnitude of plane 1 (degrees)	47	Dip magnitude of upper slope face (degrees)	10
Cohesion of plane 1 (pounds per square foot)	25	Dip direction of main slope face (degrees)	45
Water pressure on plane 1 (pounds per square foot)	0	Dip magnitude of main slope face (degrees)	65
Angle of internal friction on plane 1 (degrees)	30	Density of rock (pounds per cubic foot)	25
Dip direction of plane 2 (degrees)	18	Vertical height of highwall (feet)	20
Dip magnitude of plane 2 (degrees)	70	If the slope overhangs type -1, if the slope does not overhang type +1.	+1
Cohesion of plane 2 (pounds per square foot)	0		
Water pressure on plane 2 (pounds per square foot)	0		
Angle of internal friction on plane 2 (degrees)	35		

Figure 3.21 - Recalculation of Wedge Stability Under Dry Conditions

**Wedge Stability**

**Wedge Stability**

Input parameters by clicking to each block then clicking the appropriate command button.

Any consistent units may be used with this program. Imperial units are included only for reference.

Dip direction of plane 1 (degrees)	52	Dip direction of upper slope face (degrees)	45
Dip magnitude of plane 1 (degrees)	47	Dip magnitude of upper slope face (degrees)	10
Cohesion of plane 1 (pounds per square foot)	25	Dip direction of main slope face (degrees)	45
Water pressure on plane 1 (pounds per square foot)	30	Dip magnitude of main slope face (degrees)	65
Angle of internal friction on plane 1 (degrees)	30	Density of rock (pounds per cubic foot)	25
Dip direction of plane 2 (degrees)	18	Vertical height of highwall (feet)	20
Dip magnitude of plane 2 (degrees)	70	If the slope overhangs type -1, if the slope does not overhang type +1.	+1
Cohesion of plane 2 (pounds per square foot)	0		
Water pressure on plane 2 (pounds per square foot)	30		
Angle of internal friction on plane 2 (degrees)	35		

Figure 3.22 - Recalculation of Wedge Stability Under Saturated Conditions

imperial units have been used in PSLOPE instead of the of the U.S. units referenced on the form.

### **3.13 Back-Analysis**

PSLOPE provides the potential for back-analysis by allowing easy parameter changes and recalculations on the 'Plane Stability' or 'Wedge Stability' forms. Back-analysis is most commonly used with a failed slope where the conditions of limiting equilibrium are assumed to apply. However, assumptions can be made regarding the safety factor of a standing slope. In the plane stability problem above, for example, assume that the real cohesion was unknown and that the slope failed. To determine the cohesion required to place the slope exactly in equilibrium (safety factor equal to one) under saturated conditions, increase the cohesion value in the input box and select "Compute "until the safety factor equals one. PSLOPE determines that the cohesion required to place this slope in equilibrium is 1800 psf as shown in Figure 3.23. If the slope had not failed, a safety factor of 1.5 might be assumed. The cohesion required to maintain stability under these conditions is 3575 psf. Analyses of unfailed slopes are limited by the assumed safety factor value and should be used only with recognition of this limitation. This general procedure may also be applied to any other unknown parameter on the 'Plane Stability' and 'Wedge Stability' forms.

### **3.14 Sensitivity Studies**

PSLOPE incorporates the potential for sensitivity studies to evaluate alternative highwall designs. The program demonstrates that rock slope stability is extremely sensitive to discontinuity dip, friction angle, and hydrologic pressure. In general, safety factors decrease when the dip of the discontinuity increases or when the friction angle decreases. Increasing water pressure on a discontinuity or increasing the slope angle

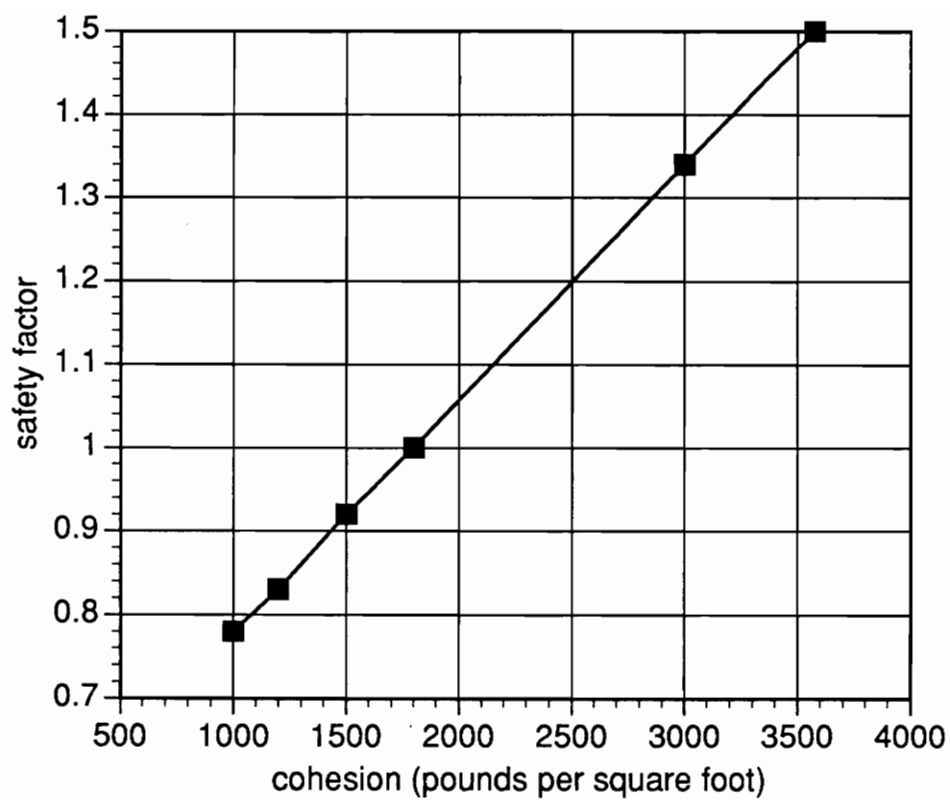

Figure 3.23 - Graph Showing Results of Back-analysis

yields approximately the same results. Increasing the slope angle in the 'Plane Stability' problem above from 60 degrees to 80 degrees will decrease the factor of safety from 0.78 to 0.47 as shown in Figure 3.24. Decreasing the friction angle in the same problem from 30 degrees to 25 degrees, will decrease the safety factor from 0.78 to 0.68. The sensitivity of any parameter may be examined in this manner.

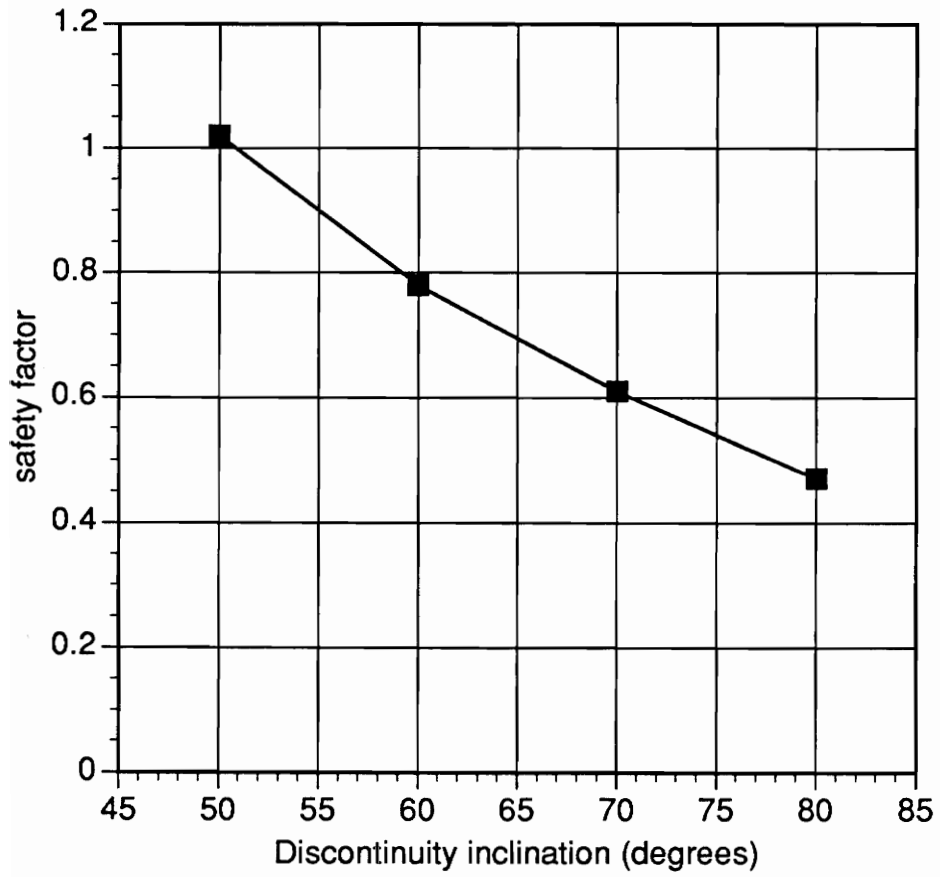

Figure 3.24 - Graph Showing Sensitivity of Slope Angle to Factor of Safety

## **CHAPTER IV. - QUARRY STABILITY EVALUATION**

### **4.1 Introduction**

This evaluation is an assessment of the final pit wall stability of a selected case study. The quarry produces approximately two and one-half million tons of limestone and dolomite aggregate per year .

Slope failures in carbonate rock and associated strata can be generally described by the following mechanisms :

- i) Raveling at slope angles above the angle of repose;
- ii) Rotational/plane failures in very low quality rock masses;
- iii) Toppling;
- iv) Failure along adverse planes.

The predominant failure mechanisms identified in these cut slopes are plane and wedge failures, which are dependent on the geological and mining conditions of the site.

### **4.2 Methodology of Evaluation**

The methodology followed in this evaluation can be divided into the following tasks:

- i) Collection of lithologic, hydrologic and structural data for the existing and proposed pit.
- ii) Division of the existing pit into discrete structural regions to facilitate slope stability analysis. The stability of each region was evaluated and, subsequently, projected to the proposed final pit limits.

iii) In order to accommodate the naturally occurring variations in physical properties such as dip angles, cohesion, and friction angles, probability methods were utilized. The reliability options of PSLOPE were used to determine ultimate pit angles.

iv) Evaluation of the effects of the critical design parameters, including cohesion, hydrologic conditions inside the slope, pit flooding, and the benchmark safety factor on the stability assessment.

### **4.3 Quarry Description**

The quarry was first opened in 1948, on the southern most portion of its property, in order to produce dimension stone for the local building industry. In 1972 this pit was flooded by Hurricane Agnes and operations were moved to the north side of the public highway. Today the property consists of approximately 690 contiguous acres.

The active quarry is an elongated, S-shaped operation, approximately 1200 ft. wide and 16,000 ft. long as shown in Figure 4.1 and Plate 4.1. The quarry is advancing from south to north following the limited outcrop of the Cockeysville Marble. The quarry is most developed north of the office shop complex, where the pit floor elevation is at approximately 80 ft. above sea level. Northward, in the central portion of the mine, a series of 50 to 90 ft. benches are developed upward to the 300 ft. level. North of the central area at elevations above 300 feet, the company is intermittently clearing and grubbing for waste rock removal. Overburden is occasionally removed in this area.

The quarry is mined by the traditional method of drill, shoot, load, and haul. Air rotatory drills with tricone bits are used to cut six inch diameter holes to predetermined depths. The drill holes are charged with a bulk Ammonium Nitrate Fuel Oil mix (ANFO)

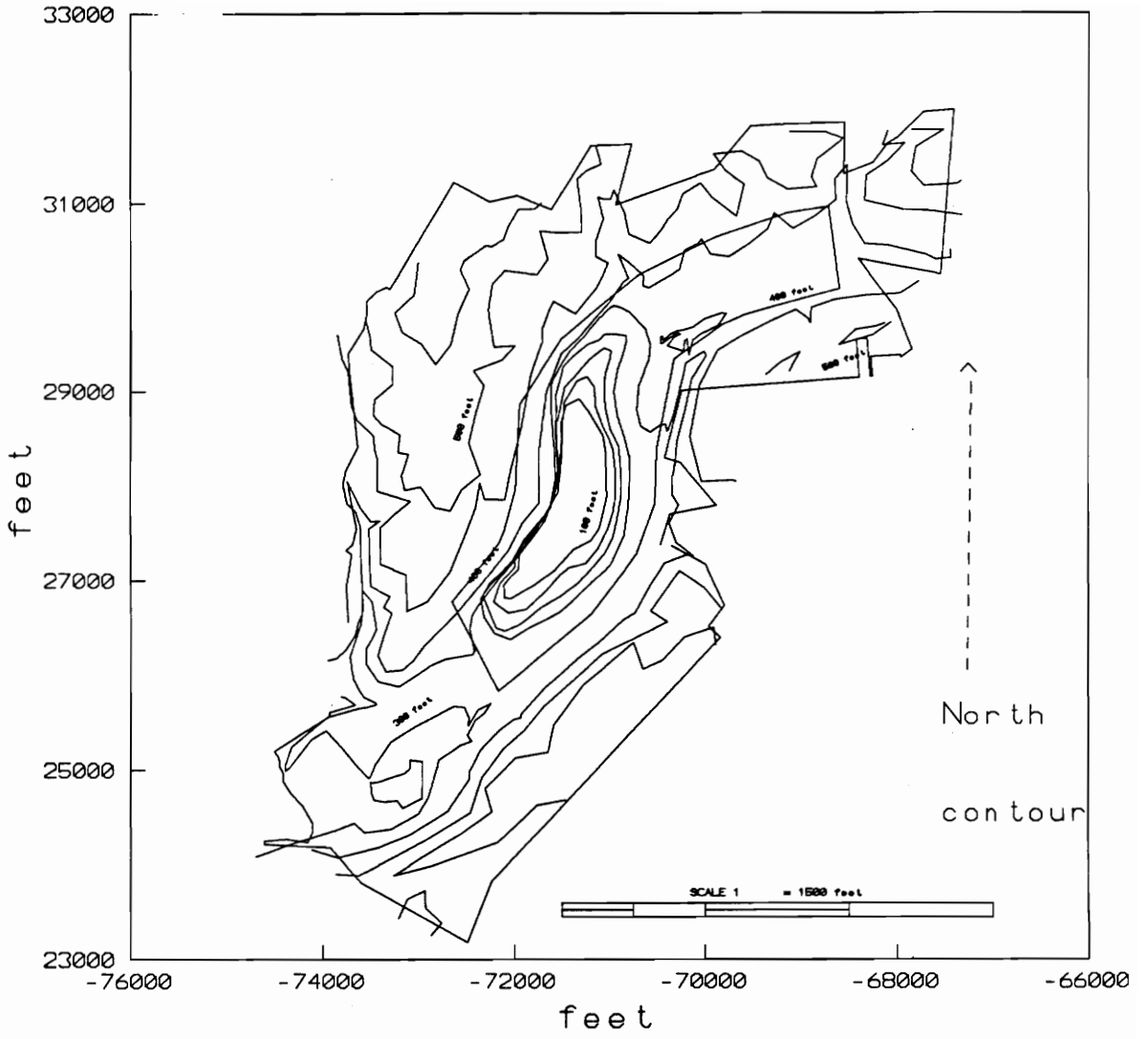

Figure 4.1 - Map Showing Quarry Topography



Plate 4.1 - Quarry Evaluated for Stability

and detonated nonelectrically. Drilling and blasting services are contracted to independent operators. Typical shots yield from 15,000 to 30,000 tons, and oversized boulders are broken by one of three cranes using impact weights. The quarry operates a fleet of front end loaders and haul trucks that transport the blasted material to either the 305 Plant or the 313 Plant, where it is crushed and screened.

#### **4.4 Mine Plans**

Current mine plans anticipate a 45 degree face angle with 50 foot benches and an ultimate floor elevation of 100 ft. below sea level. This design is primarily the result of overburden to product recovery ratios and practical operational considerations and does not reflect stability considerations. With this plan, the mineable limit of the quarry contains approximately 160 acres and has a projected life of approximately 50 years. Face angles less than or greater than those anticipated will significantly affect the recoverable reserves and life of the quarry.

#### **4.5 Geology**

The quarry is situated in the east central portion of the Piedmont Physiographic Providence of Maryland. The quarry produces from the Cockeyville Marble of the Glenarm Supergroup that is Ordovician in age.

The 600 foot thick Cockeyville Marble is overlain by the Loch Raven Schist and is underlain by the Setters Gneiss as shown in Figure 4.2. A granitic dome of Silurian age crops out 5000 feet southeast of the quarry. Regional faulting and fracturing are associated with the dome. Just east of the quarry, the Glenarm Supergroup dips west on a gentle anticline associated with the northwest flank of the dome.

WEST

EAST

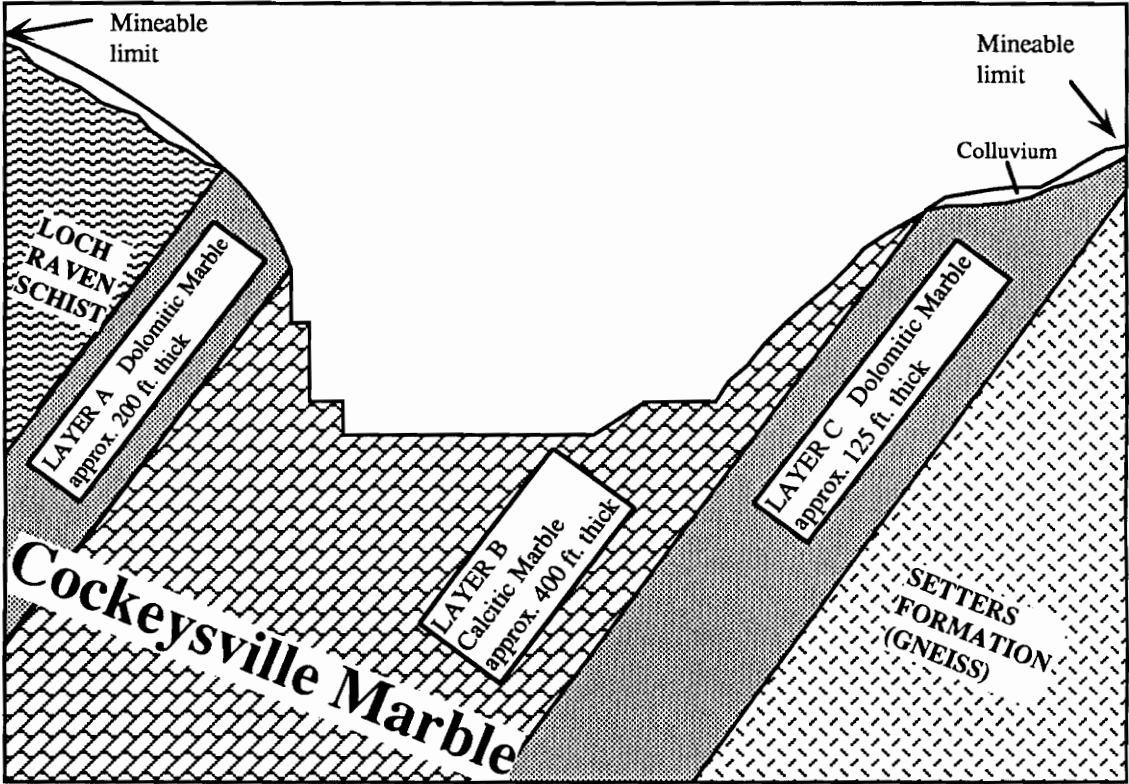

not to scale

Figure 4.2 - Geologic Cross-section of Quarry

The accepted genetic interpretation of the Glenarm Supergroup is that of detrital sediment and limestone, metamorphosed by heat and pressure associated with basement uplift and intrusion of the dome and other regional activity. In general, limestone is recrystallized to marble. Sandstone and shale are recrystallized to schist and gneiss, with gneiss representing a higher grade of metamorphism.

Comprehensive study of the Cockeysville Marble at the quarry by the operating company suggested that, for mining purposes, the formation could be subdivided into a soil horizon and three distinct lithologies.

Drill holes and overburden removal experience at the quarry suggest that soil profiles overlying the intact rock of the Glenarm Supergroup average approximately 30 feet. The central portion of the active pit recently encountered a colluvial/alluvial deposit approximately 100 ft. thick that rotated into the active work area causing minor production interruptions.

The upper lithology is a white, light brown to light gray, fine to occasionally medium grained dolomitic marble, rich in magnesium and poor in silica, approximately 100 feet thick. Los Angeles (LA) hardness tests from numerous core holes have determined values between 45 and 76%. This layer is moderately fractured along its bedding plane. It dips 20 to 35 degrees west in the southern portion of the quarry and 30 to 45 degrees northwest in the northern portion of the property. This lithology dominates the west quarry wall.

The middle lithology is a hard, gray to purple, fine to medium grained phlogopitic calcite marble, rich in silica and calcite, approximately 400 feet thick. LA hardness tests from numerous core holes have yielded values ranging between 31 and 48%. This layer dips from 25 to 40 degrees west in the south portion of the property and 35 to 45 degrees northwest in the northern portion of the property. Tension and compression joints

associated with uplift and folding by the Woodstock dome are well developed. Chlorite is the predominant fracture filler. Complex small-scale faulting, sub-parallel to the bedding plane, is evident in the central portion of the active pit. This lithology dominates the quarry floor.

The lower lithology is a soft, whitish, fine to medium grained, dolomitic marble, rich in magnesium and poor in silica, approximately 125 feet thick. This layer dips from 30 to 40 degrees west in the southern portion of the property and 30 to 45 degrees northwest in the northern portion of the property where it is heavily fractured. Calcite and quartz are the predominant fracture fillers in the north portion of the property. LA hardness tests from numerous core holes have yielded values ranging between 43 and 73%. This lithology dominates the eastern quarry wall.

Numerous tonolite and diabase dikes intercept the Cockeysville Marble. The dikes are most abundant in the central portion of the quarry. They are usually sub-perpendicular to the bedding plane and attain thicknesses of up to several feet. The USGS Reisterstown Geologic Quadrangle Map (Crowley, 1977) shows a pegmatite intrusion several hundred feet thick, about 600 feet northwest of the quarry's recoverable reserve area.

The gentle westward plunging anticline associated with the dome may control faulting, jointing, and the presence of dikes within the quarry. Both tension and compression joint sets are well developed in the active quarry. Field measurements of discontinuities and the USGS Ellicott City Quadrangle Map (Crowley and Reinhardt, 1980) and Reistertown Geologic Quadrangle Map (Crowley, 1977) suggest that the central portion of the quarry lies within a small fold of this anticline and that the northern boundary of the quarry lies on the axis of the anticline. Drilling by the operating company has identified a subsurface normal fault with displacement of approximately 80 feet in the

northern portion of the property, and additional minor faulting is suspected in the northwest portion of this area.

#### **4.6 Hydrology**

Comprehensive hydrologic information on the quarry is not available. Although numerous core holes have been drilled, a water monitoring system is not in place. Some comments on hydrology can be made, however, based on studies from outside the mine property and from pit pumping information.

The quarry lies within the drainage of the Patapsco River between two smaller tributaries. Both tributaries enter the Patapsco River along the southwest boundary of the quarry property, as shown in Figure 4.3. The eastern tributary has a watershed of approximately 2048 acres above the quarry. The western tributary has a watershed of approximately 230 acres above the quarry.

National Weather Service data shows that the 25 year one-hour rainfall is approximately 2.6 inches. Standard rainfall intensity-duration curves (Bedient, 1992) show rainfall intensities of approximately 4.0 inches per hour for a 30 minute event with 2.6 inches of depth.

Damp areas were visible in the east and west pit walls of the active quarry. Running water was observed on the highwall at several locations. Pit pumping information suggests that an average of about 350,000 gallons of water is removed from the pit daily. Higher rates of infiltration may be expected with lateral development of the quarry, especially from the east quarry wall as the bedding plane horizon that crops out on the eastern tributary is encountered.

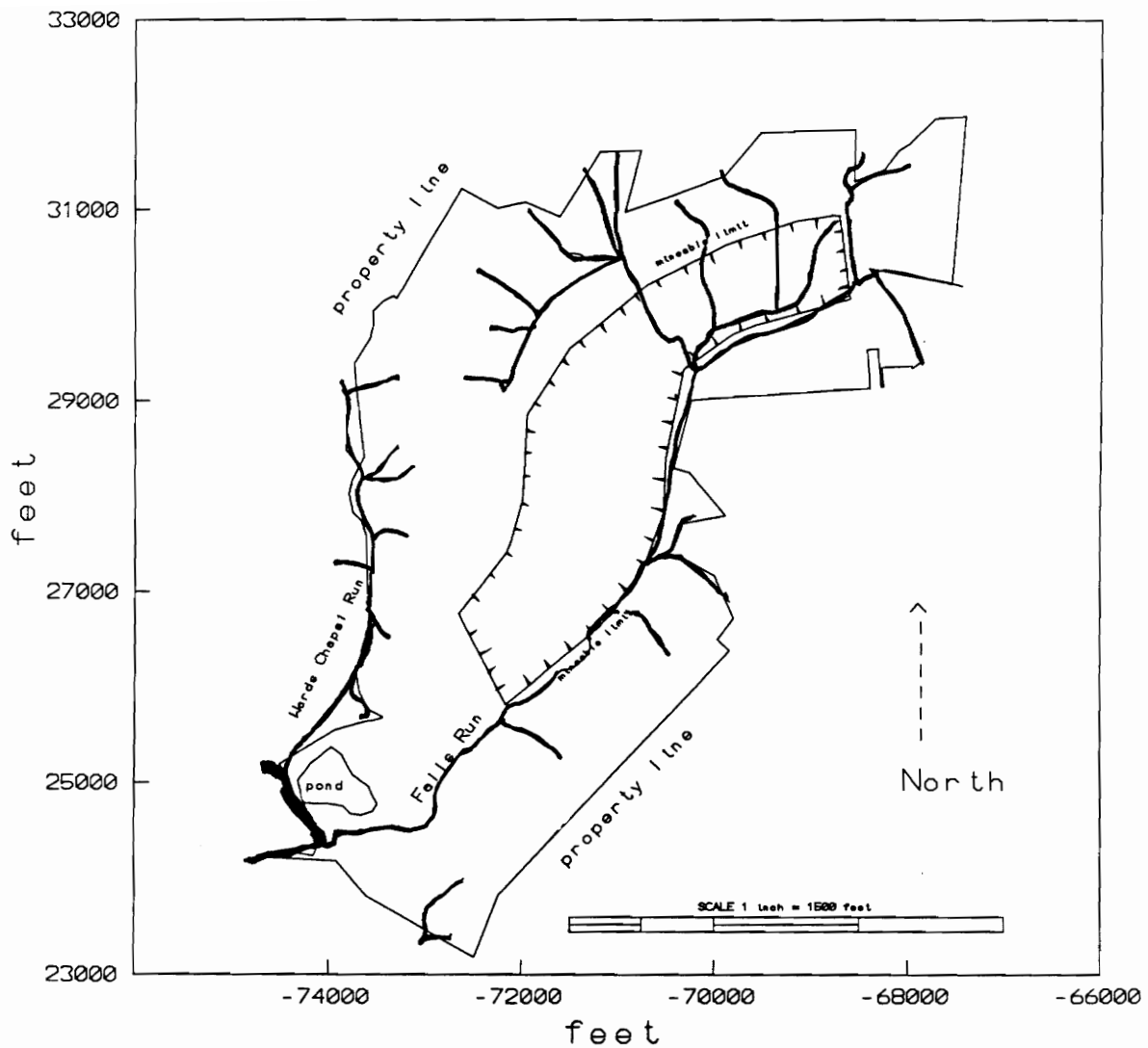

Figure 4.3 - Drainage in Area of Quarry

#### **4.7 Identification of Structural Regions**

Field mapping of discontinuities in the actively mined area suggests that, for the purposes of slope stability investigation, the quarry can be divided into two structural regions. This division was based on determinations made from nine sets of discontinuity observations (A through I) conducted within the active quarry (Figure 4.4). Comparison of discontinuity measurements on Wulff equal angle stereonet show that observation sets C, D, E, and G in the southern portion of the quarry and observation sets A, B, F, H, and I in the northern portion of the quarry compose unique structural regions. Table 4.1 and Figures 4.5 to 4.8 summarize the measurements.

Structural Region I lies in the southern portion of the quarry and consists of the bedding plane dipping 44 degrees in the direction 306 degrees and four joint planes . Structural Region II lies in the northern portion of the quarry and consists of the bedding plane dipping 43 degrees in the direction 297 degrees and six joint planes.

#### **4.8 Rock Mass Rating**

Slope stability analysis of pit walls at the quarry requires investigation of the mechanisms that can lead to raveling, rotational, toppling, plane, and wedge failures at the mine.

An RMR of 78 is estimated for the Cockeysville Marble at the quarry. This relatively high value suggests that a "good" to "very good" rock quality designation is appropriate for the quarry. Values assigned in determination of the RMR include a six for the strength of the rock, a 17 for drill core quality (RQD), a 25 for discontinuity spacing, a 20 for discontinuity characteristics , and a ten for groundwater conditions. These results are summarized in Table 4.2.

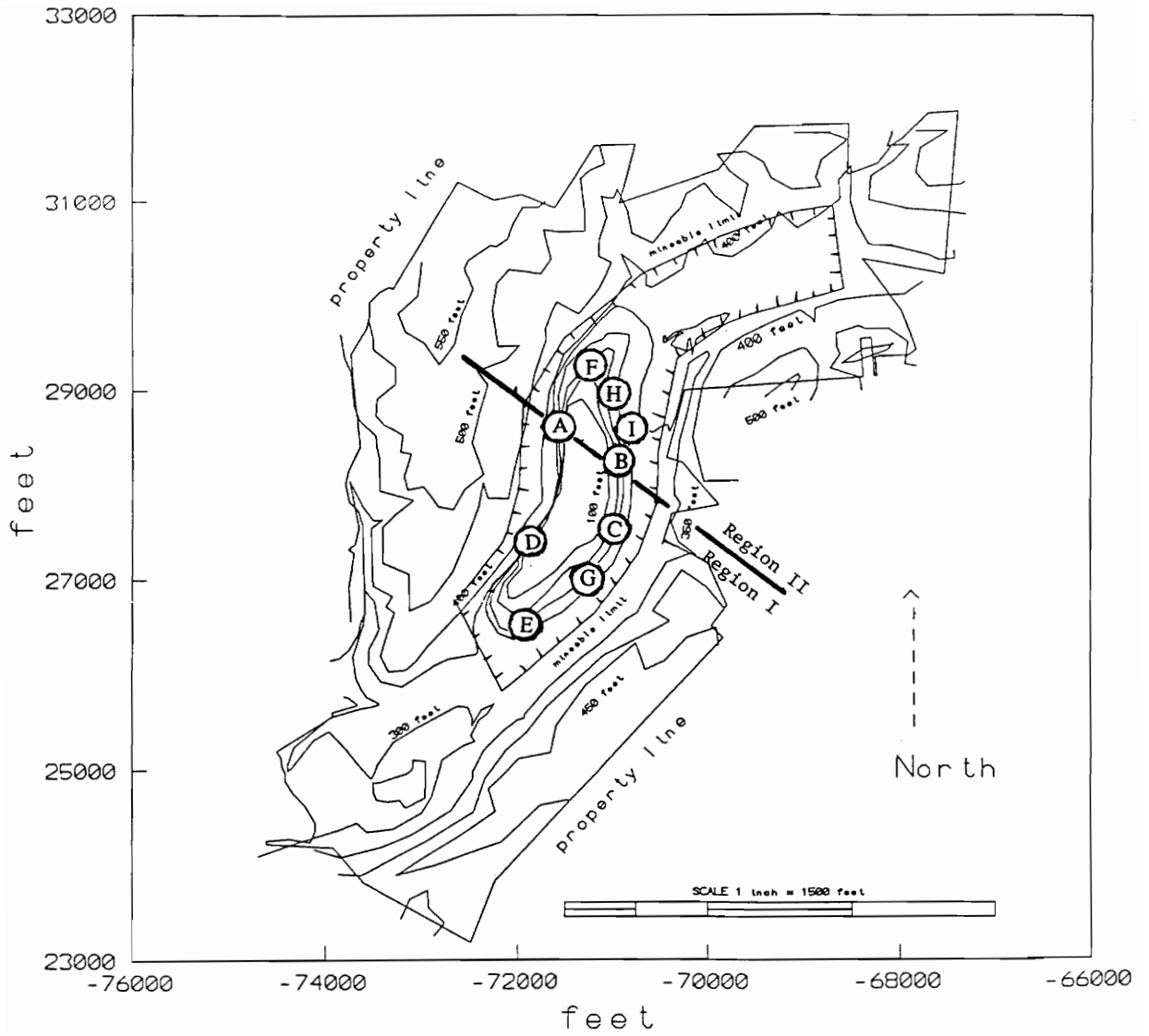

Figure 4.4 - Location of Discontinuity Measurements in Quarry

Table 4.1 -Summary of Discontinuity Measurements

Dip Direction		Dip Magnitude	
mean	standard deviation	mean	standard deviation
Structural Region I (degrees)			
306	15	44	14 *
165	12	78	6
110	14	72	11
67	7	67	14
266	2.7	82	2
Structural Region II (degrees)			
297	24	43	12 *
355	7	86	2
144	7	75	8
120	10	70	8
269	4	74	4
209	18	48	8
329	7	75	8
* bedding plane			

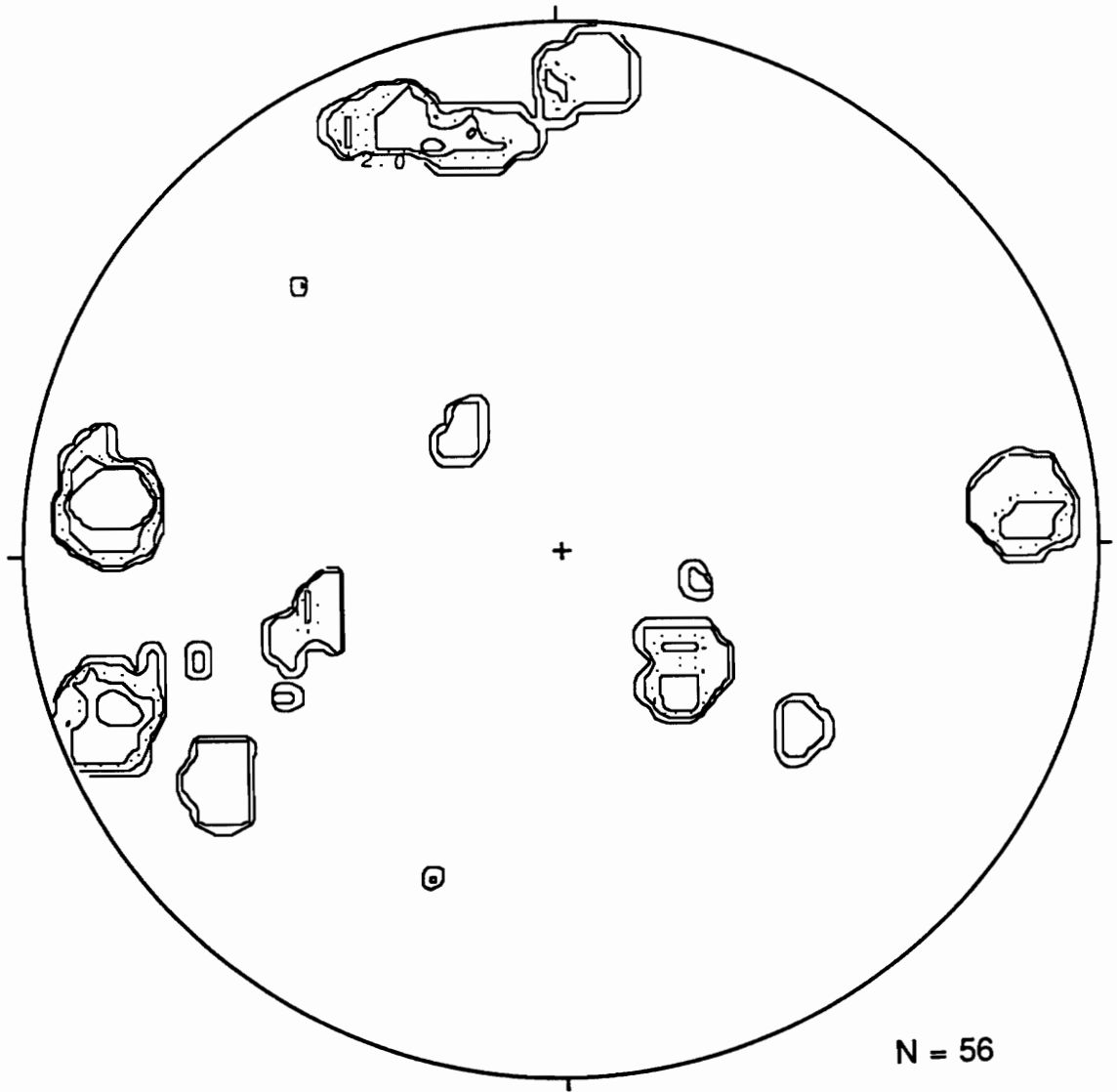

Figure 4.5 - Stereographic Contours of Discontinuity Poles, Structural Region I

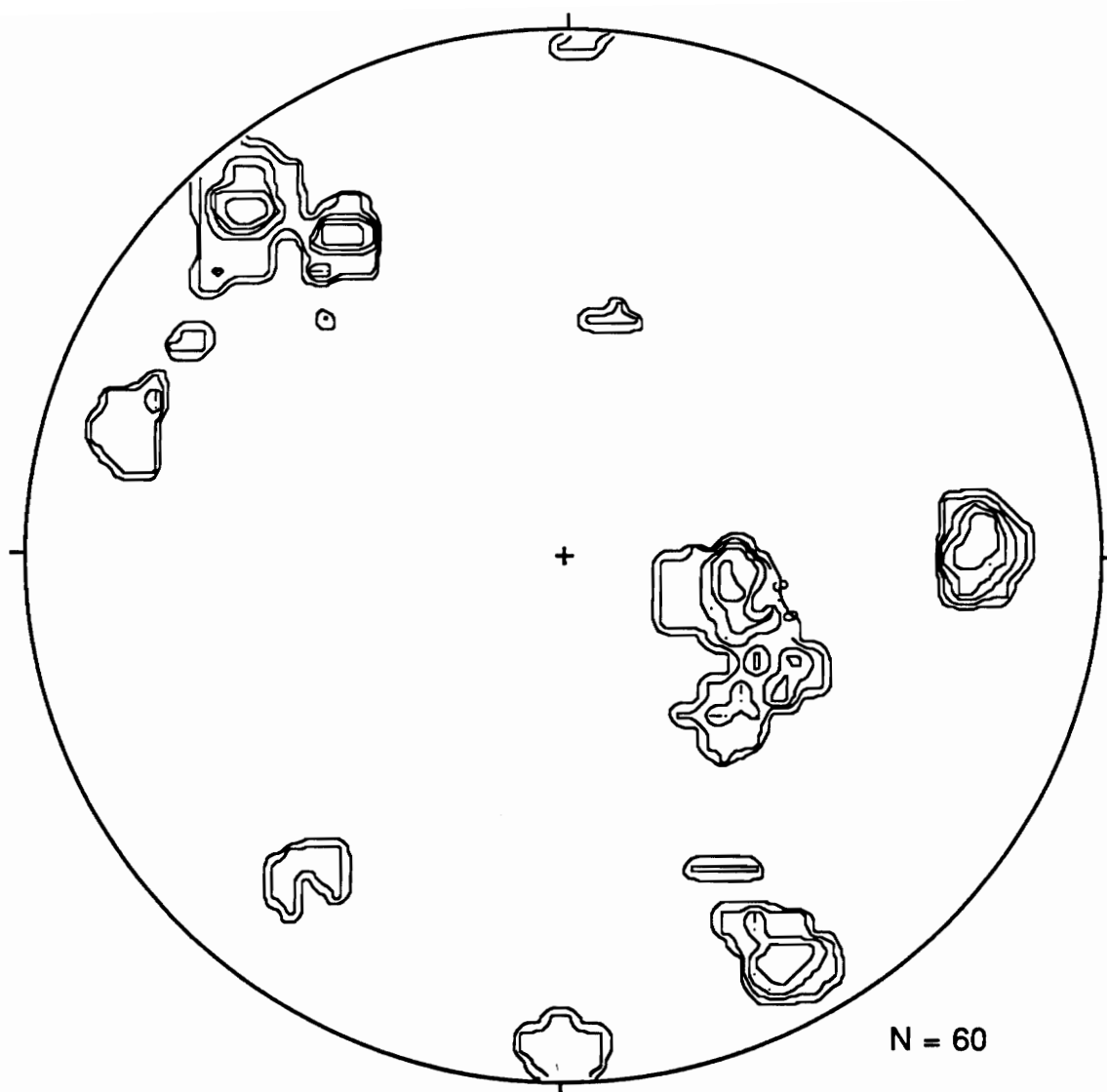

Figure 4.6 - Stereographic Contours of Discontinuity Poles, Structural Region II

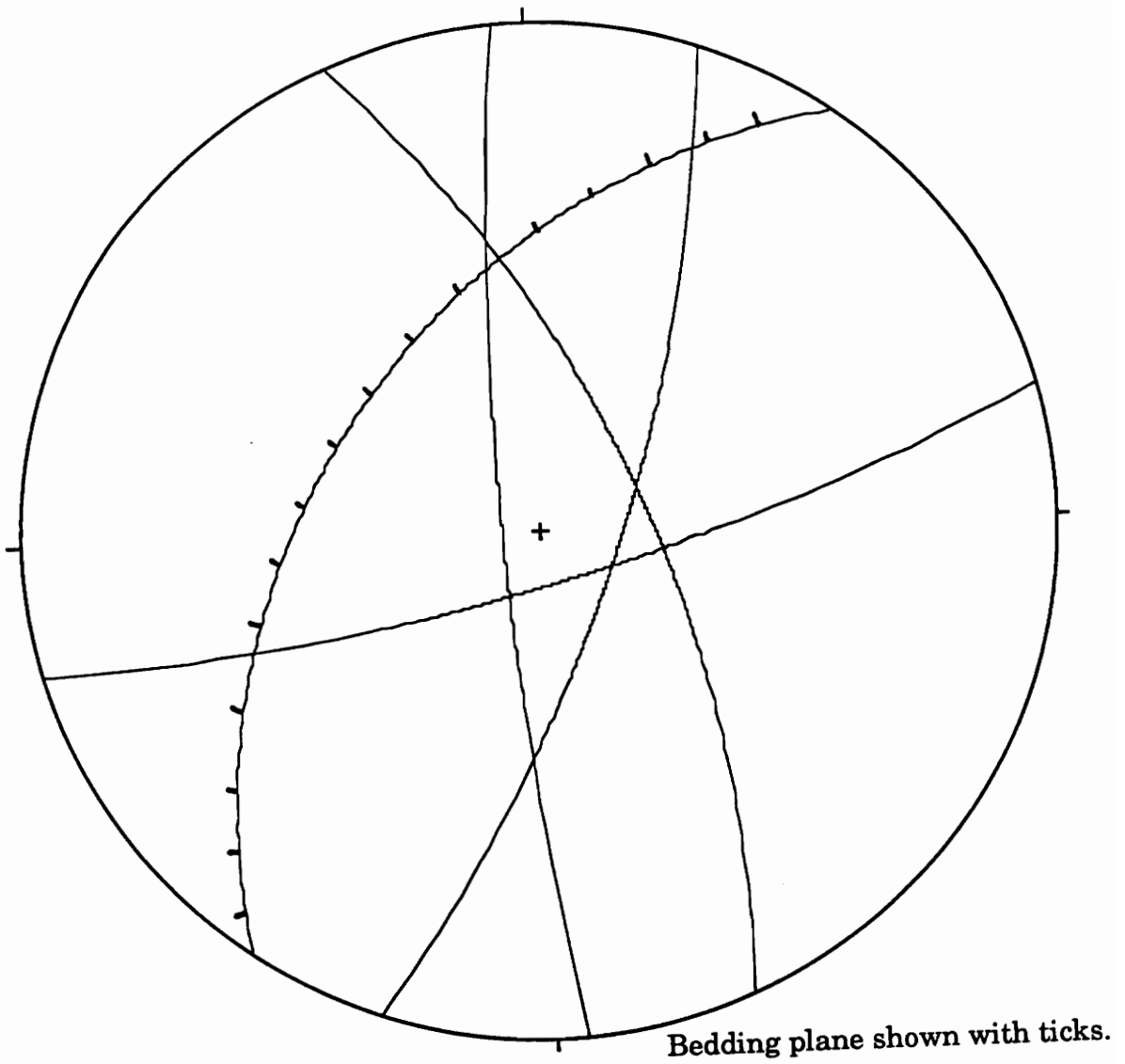

Figure 4.7 - Projections of Mean Discontinuity Planes, Structural Region I

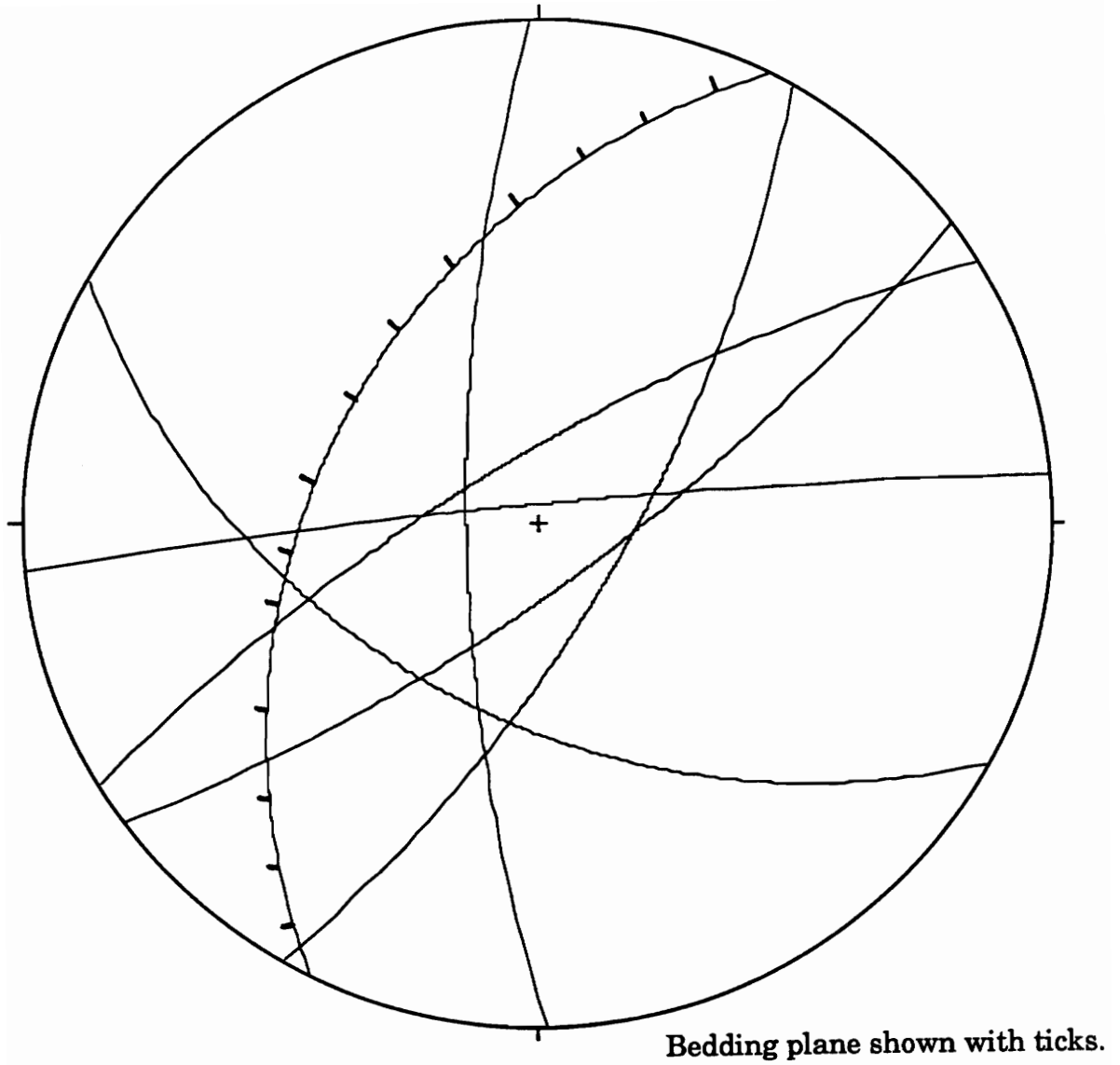

Figure 4.8 - Projections of Mean Discontinuity Planes, Structural Region II

**Table 4.2 - Rock Mass Rating (RMR) of Quarry**

<b>Parameter</b>	<b>Value</b>	<b>RMR Index</b>
<b>Compressive Strength</b>	<b>50 MPa</b>	<b>6</b>
<b>RQD</b>	<b>75-90</b>	<b>17</b>
<b>Discontinuity spacing</b>	<b>1-3 ft</b>	<b>25</b>
<b>Joint surface</b>	<b>rough</b>	<b>20</b>
<b>Groundwater</b>	<b>damp</b>	<b>10</b>
<b>RMR Rating</b>		<b>78</b>
<b>Description</b>	<b>Good to Very Good Rock</b>	

#### **4.9 Potential Failure Modes**

Potential slope failures can be generally described by the following failure mechanisms (Afrouz, 1992).

Slope disintegration by raveling is particularly noticeable at slope angles above the angle of repose, measured as 30 degrees at the quarry. In the most practical sense, small-scale raveling of the ultimate pit wall of the quarry is unavoidable. However, large-scale degradation of the pit wall by raveling is not a potential mechanism for major failure at the quarry.

The potential for rotational or rotational/plane failures exists even in very strong rocks if they are highly fragmented relative to the slope height. Estimates of rock mass integrity based on the Rock Mass Rating (RMR) system suggest that rotational and rotational/plane failures are not potential mechanisms for large-scale failure at the quarry.

Slope disintegration by toppling of columns or blocks of rock about some fixed base requires weak rock and vertical jointing sub-parallel to the slope face. Stereographic analysis of the measured discontinuities shows no vertical planes sub-parallel to any of the ultimate pit walls. Toppling is not a potential mechanism for large-scale failure at the quarry.

Discontinuity geometry within the rock mass of a highwall and the orientation of the face are factors that must also be considered in analysis of slope stability for plane and wedge failure. These orientations can determine whether the rock mass will remain in place or whether portions of it are free to slide. Failure may occur along a single plane or in a combination of planes as a wedge. Review of structural conditions at the quarry suggests that these are likely to be the predominant failure mechanisms and that they are worthy of detailed analysis.

#### **4.10 Analysis of Plane and Wedge Failures**

The reliability options of PSLOPE were used to evaluate the ultimate highwall at the quarry for wedge and plane failures. Eleven "design areas" were developed from the approximate strike directions of the projected mineable limit, as shown in Figure 4.9. Table 4.3 describes each "design area" with the azimuth of the highwall dip direction. The magnitude of dip in each "design area" is determined from the stability analysis. The quarry was subdivided into two "structural regions" based on field measurements of rock discontinuities. A "wedging factor" is included in the analysis.

#### **4.11 Reliability Evaluations**

Since mapping of structural data was only carried out on the existing quarry faces and extrapolation to the projected pit limits was necessary, a probability approach was utilized to evaluate stability (CANMET, 1976). This method of evaluation permitted the use of all available data. Reliability analyses were performed for each "design area" for a variety of geotechnical conditions. Each simulation yielded 10,000 combinations of data derived from the actual discontinuity measurements and laboratory tests.

Input values of the simulation include laboratory estimates of the internal friction angle. Tests of ten samples yielded a mean friction angle of 40 degrees with a standard deviation of two degrees. This value includes the effect of aspirates.

The simulation first selects a set of data from the overall data set. The simulation then checks for critical conditions (dip of discontinuity is between face angle and friction angle). A safety factor is then calculated for each data combination found to be critical. The number of safety factors greater than the benchmark safety factor of 1.5 is summed. Reliability in slope stability is the sum of the number of safety factors greater than 1.5

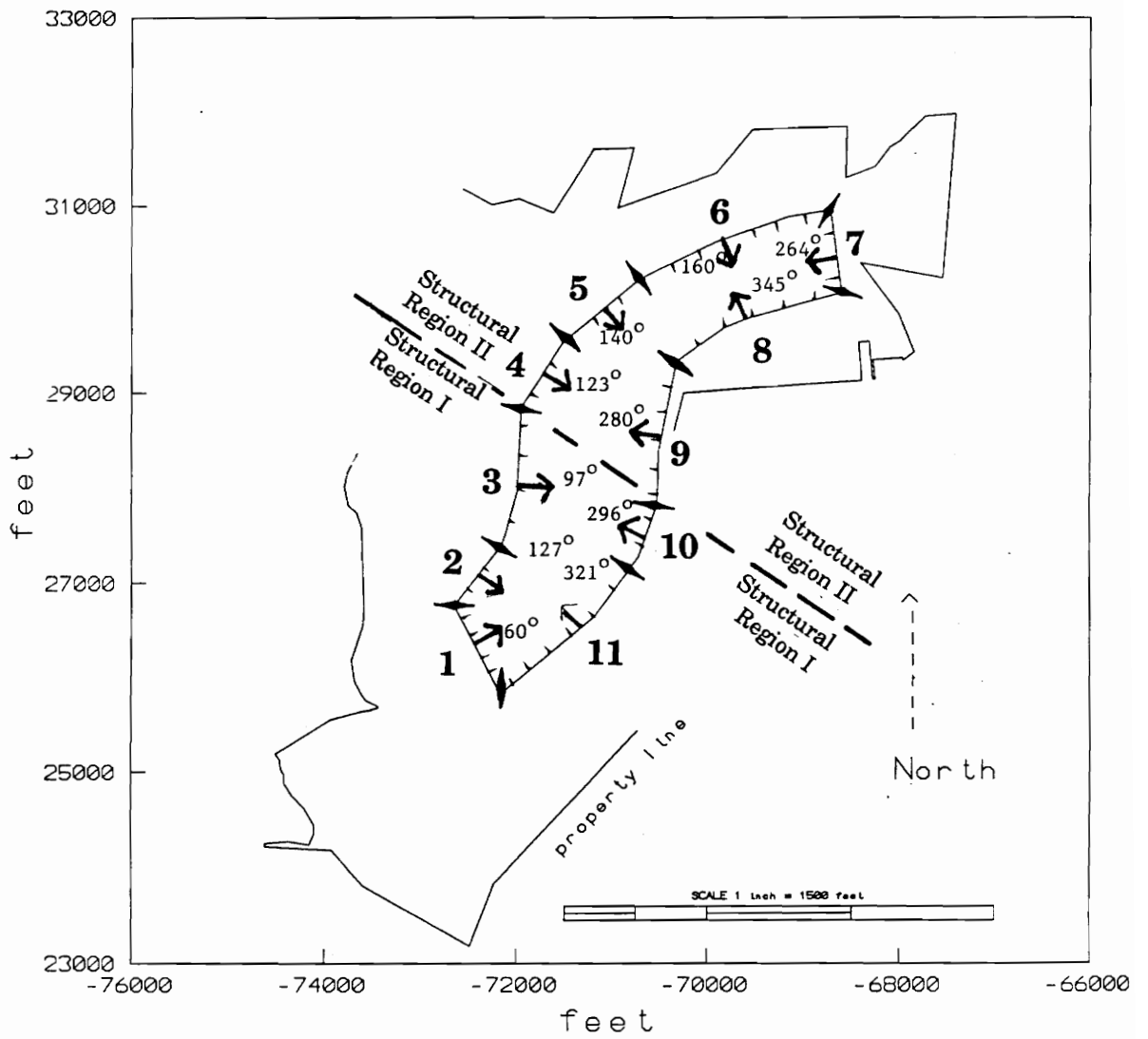

Figure 4.9 - Design Areas Projected from Mineable Limit

Table 4.3 - Design Area Dip Azimuths

Design Area	Dip Azimuth (degrees)	Structural Region
1	60	I
2	127	I
3	97	I
4	123	II
5	140	II
6	160	II
7	264	II
8	345	II
9	280	II
10	296	I
11	321	I

divided by the total number of safety factor calculations. Reliability varies as a function of face angle, cohesion, and hydrologic conditions. The results are reported in tables.

#### **4.12 Analytical Assumptions**

A number of assumptions were necessary to conduct the stability analysis. Assigning values for critical parameters that are highly conservative or liberal must be avoided for realistic solutions.

Highly jointed carbonates rarely show good continuity throughout an entire formation. However, for the purposes of the analysis, sufficient continuity is assumed to produce a slide of noticeable proportions. Such planes may include step failures in some areas.

For plane and wedge failure to form, release surfaces must exist that do not present significant resistance to failure. As a worst case, long-term condition, such surfaces are assumed to exist.

Water is the primary cause of most slope failures due to the resulting uplift pressures along the discontinuity interface. Such pressures reduce effective friction forces across a potential failure plane by decreasing the normal stress. Instantaneous filling of fractures and tension cracks during periods of high precipitation is the principal triggering mechanism of rock slope failure. In limestones, as in many rock masses, the distribution of water pressure is controlled by discontinuities and is difficult to define without extensive field measurements. Since these conditions are not particularly susceptible to theoretical analysis, major assumptions must be made for the purposes of calculation.

The accepted "worst case" condition is described by a saturated discontinuity that is intersected by a tension crack from the surface. A triangular distribution of water pressure is assumed for this situation.

#### **4.13 Flooded Pit Condition**

Current mine plans show that with the cessation of mining, the quarry pit will fill with water to an elevation of approximately 300 feet. The flooded pit will outflow into the eastern tributary at the southern limit of the quarry.

As the pit is allowed to flood, the water will generate lateral pressures that will effectively offset any pressures occurring along a tension crack and potential failure plane due to slope saturation. As shown in Figure 4.10, the force from the weight of the water will tend to balance the pressure developed from the saturated tension crack. The presence of water in the pit will significantly enhance stability. It is, therefore, reasonable to assume that "flooded pit conditions" are in effect similar to dry slope conditions, and as a result, "saturated slope conditions" can be considered as the worst case scenario.

The assumption that the flooded pit will support the slope also affects the normal force acting on the discontinuity plane. The portion of the slope below the water level is subject to a buoyancy effect that reduces the weight of the rock overlying the discontinuity plane. The net effect of this phenomenon yields a conservative stability estimate.

Flooded pit conditions affect the largest portion of the mine. However, a highwall ranging between 95 and 180 feet will remain above water level on the west side of the quarry. On the east side of the mine, the highwall remaining above water level will average approximately 35 feet.

Cohesion across critical discontinuities is a major factor in assessing slope stability. Since in-situ measurements were not available, back-analysis was carried out on existing stable slopes to determine a range of possible values. Three independent determinations of cohesion were made on the north, central, and south areas of the west wall of the quarry for dry, damp, and wet conditions. In these estimates, the factor of safety was

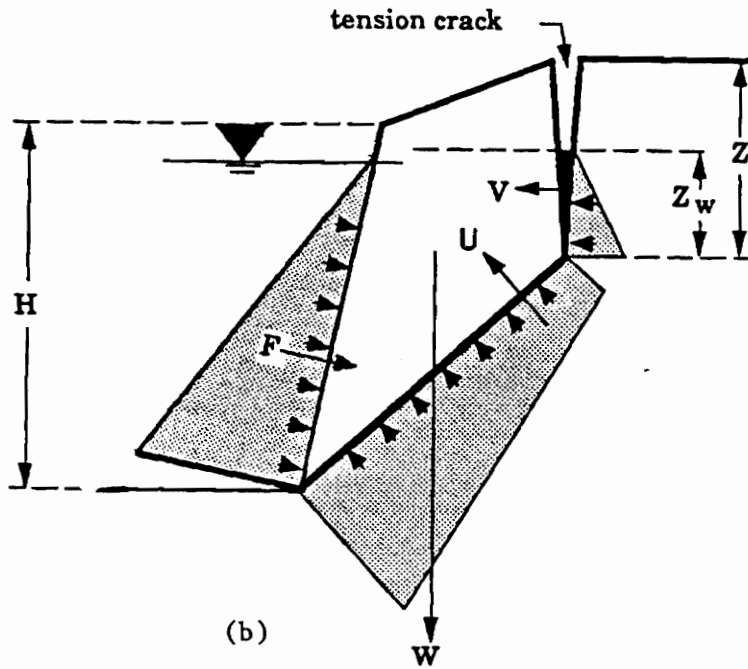

- (b)
- $H$  = height of slope
  - $Z$  = depth of tension crack
  - $Z_w$  = depth of water in tension crack
  - $W$  = weight of block
  - $F$  = water pressure acting on slope face
  - $U$  = uplift pressure on water under block
  - $V$  = water pressure acting behind block

Figure 4.10 - Distribution of Hydraulic Forces Under Flooded Pit Conditions

calculated for each hydrologic condition using the most unstable discontinuity combination, the observed inclination and azimuth of the active highwall, and zero cohesion. Cohesion was subsequently increased until the calculated safety factor exceeded 1.5. This method of cohesion assessment assumes that destabilization of the slope by water pressure is proportional to stabilization by cohesion and can be regarded as the additional strength required to maintain stability under increasingly detrimental hydrologic conditions. This method of cohesion assessment is limited by the factor of safety assumption. The back-analysis yielded cohesion values between 2,500 psf and 18,000 psf.

For simulation purposes, critical cohesion values of zero, 4,000 psf, and 9,000 psf (i.e. minimum and maximum of damp conditions) were selected.

The design standard for this stability evaluation is 1.5. Higher or lower reliability can be attained by repeating the simulation using a higher or lower benchmark safety factor.

#### **4.14 Results of Analysis**

Analytical evaluation of the Wulff equal angle stereonet for each of the eleven "design areas" revealed discontinuity combinations that are critical for each area. The stereographic plot of Design Area 1 is presented as an example in Figure 4.11. Table 4.4 summarizes critical discontinuity combinations for each design area. The results show that wedge failure may be considered the predominant mechanism in all design areas except 10 and 11, where plane failure is the dominating failure mode. The stereonet also show that bedding is the most influential discontinuity. Design Areas 10 and 11 are controlled by the bedding plane that dips parallel to these projected slope faces. Design Areas 7 and 9 are controlled by bedding plane wedges that plunge in a direction nearly parallel to the dip of these projected slope faces.

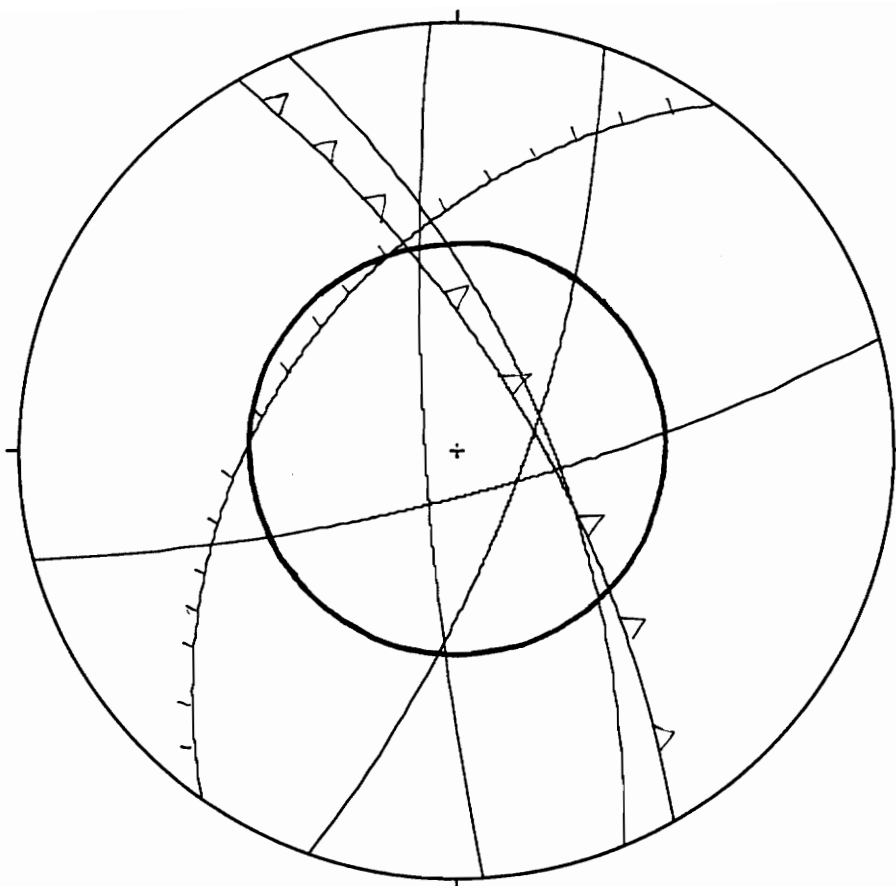

Data	Wulff Equal Angle Projection	Remarks
Design Area 1	<p style="text-align: center;">N = 6</p>	<p>Bedding plane shown with ticks. 70 degree slope face (barbs) and 40 degree friction circle shown for reference.</p> <p>Critical discontinuity combinations shown as solid circles.</p>

Figure 4.11 - Wulff Equal Angle Projections - Design Area 1

Table 4.4 - Critical Discontinuity Combinations for Design Areas

Design Area	combination	Critical Discontinuities				Intersection of Discontinuities	
		dip direction		dip magnitude		dip direction	dip magnitude
		mean	standard deviation	mean	standard deviation		
		(degrees)					
1	a	109	14	72	11		
		165	12	78	6	120	85
	b *	165	12	78	6		
		67	7	67	14	100	65
	c	109	14	72	11		
		67	7	67	14	68	69
2	a	109	14	72	11		
		165	12	78	6	120	85
	b *	165	12	78	6		
		67	7	67	14	100	65
	c	109	14	72	11		
		266	3	82	2	187	44
3	a	109	14	72	11		
		165	12	78	6	120	85
	b	109	14	72	11		
		67	7	67	14	68	69
	c *	165	12	78	6		
		67	7	67	14	100	65
4	a	120	10	70	8		
		355	7	86	2	76	66
	b	144	7	75	8		
		120	10	70	8	96	71
	c *	355	7	86	2		
		144	7	75	8	80	58
5	a	208	8	48	8		
		269	4	74	4	199	48
	b	120	10	70	8		
		269	4	74	4	194	40
	c *	208	8	48	8		
		120	10	70	8	189	46
6	a *	269	4	74	4		
		120	10	70	8	194	40
	b	120	10	70	8		
		209	18	48	8	189	46
	c	209	18	48	8		
		269	4	74	4	199	48
7	a	209	18	48	8		
		329	7	75	8	252	42
	b *	209	18	48	8		
		297	24	43	12	258	38
	c	329	7	75	8		
		297	24	43	12	248	34
	d	355	7	86	2		
		297	24	43	12	268	39
8		297	24	43	12		
		269	4	74	4	348	32
9	a	209	18	48	8		
		329	7	75	8	252	42
	b *	209	18	48	8		
		297	24	43	12	258	38
	c	329	7	75	8		
		297	24	43	12	248	34
	d	297	24	43	12		
		355	7	86	2	268	39
10		306	15	44	14	not applicable	
11		306	15	44	14	not applicable	

\* controlling discontinuity

The effects of slope angle on reliability for different levels of cohesion and for both saturated and flooded pit conditions are presented in Figures 4.12 to 4.17 for Design Area 1. The detailed results of these analyses for all design areas are tabulated in Table 4.5 and Table 4.6. The results show that, assuming a cohesion of 4,000 psf, the critical slope angle for 85% reliability ranges from 55 degrees to 90 degrees for flooded conditions and from 30 to 58 degrees for saturated conditions. The results also show that assuming a cohesion of 9,000 psf, the critical slope angle for 85% reliability ranges from 67 degrees to 90 degrees for flooded conditions and from 47 to 80 degrees for saturated conditions. In general, the lower limit critical slope angles occur on the east quarry wall and are controlled by the bedding plane or by a discontinuity in combination with the bedding plane that forms an unstable wedge. The tables also show the impact of decreasing levels of reliability on the slope angles. Finally, the effect of reducing the safety factor from 1.5 to 1.0 on slope angle reliability is demonstrated in Figure 4.18 for one discontinuity in Design Area 1.

#### **4.15 Interpretation of Analysis**

The study shows that for highwall design purposes, the final quarry may be subdivided into three combinations of conditions: the stable west wall above 300 ft of elevation, the stable west wall below 300 ft of elevation, and the unstable east wall.

The inherently stable west wall is controlled by the bedding plane that dips into the quarry wall and the water level to which the mine is expected to fill on abandonment. Bedding planes and bedding plane discontinuity combinations (wedges) dipping into the wall do not have the free surfaces required to initiate sliding. Of the discontinuity combinations dipping east and parallel to the slope of the proposed west wall, none plunged parallel or sub-parallel with the slope azimuth of the proposed wall. Therefore,

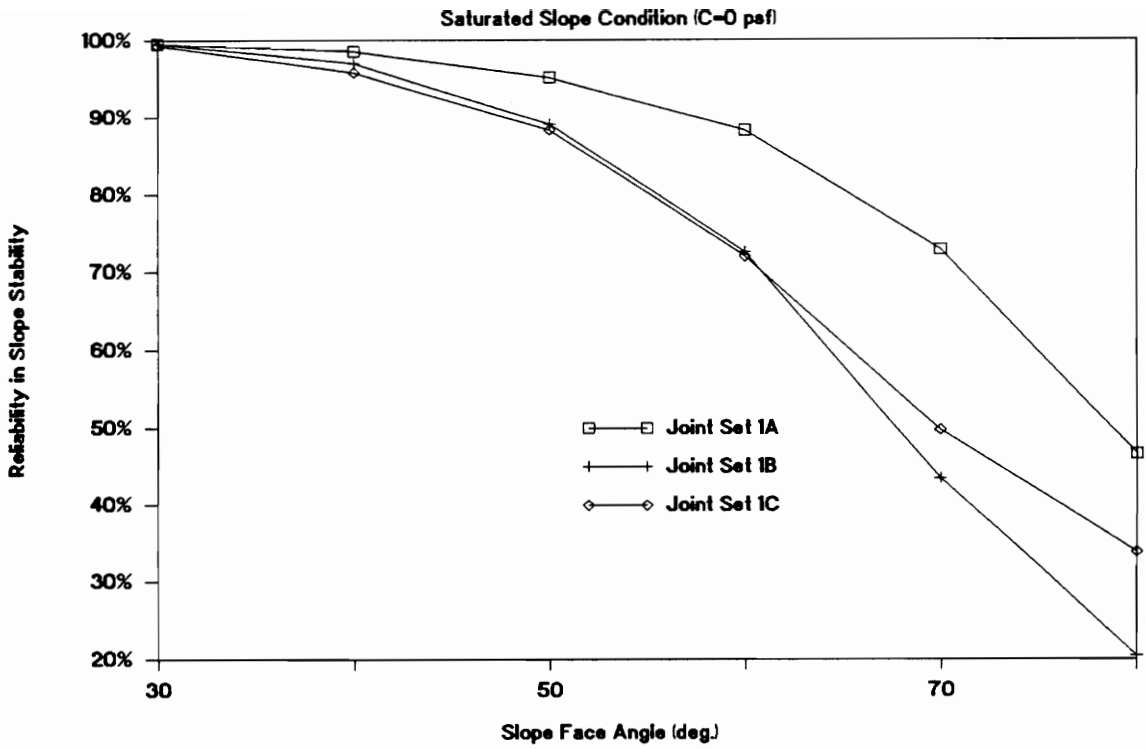

Figure 4.12 - Reliability Graph, Design Area 1, Saturated Conditions,  $c = 0$

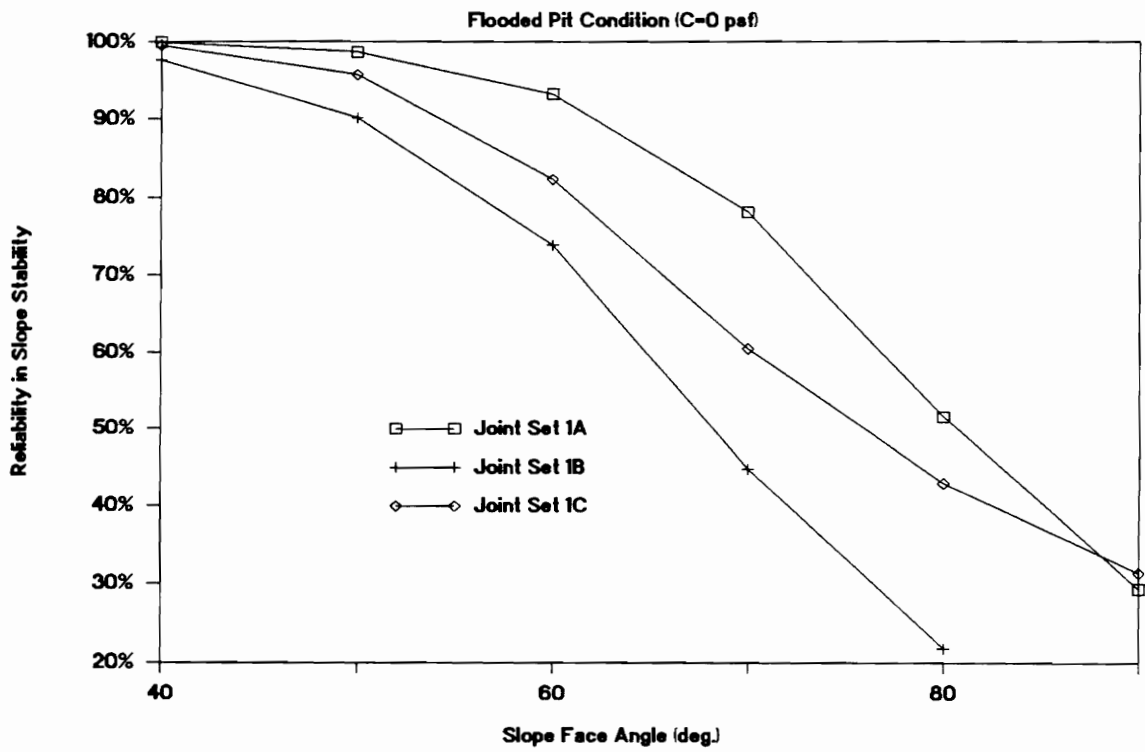

Figure 4.13 - Reliability Graph, Design Area 1, Flooded Pit Conditions,  $c = 0$

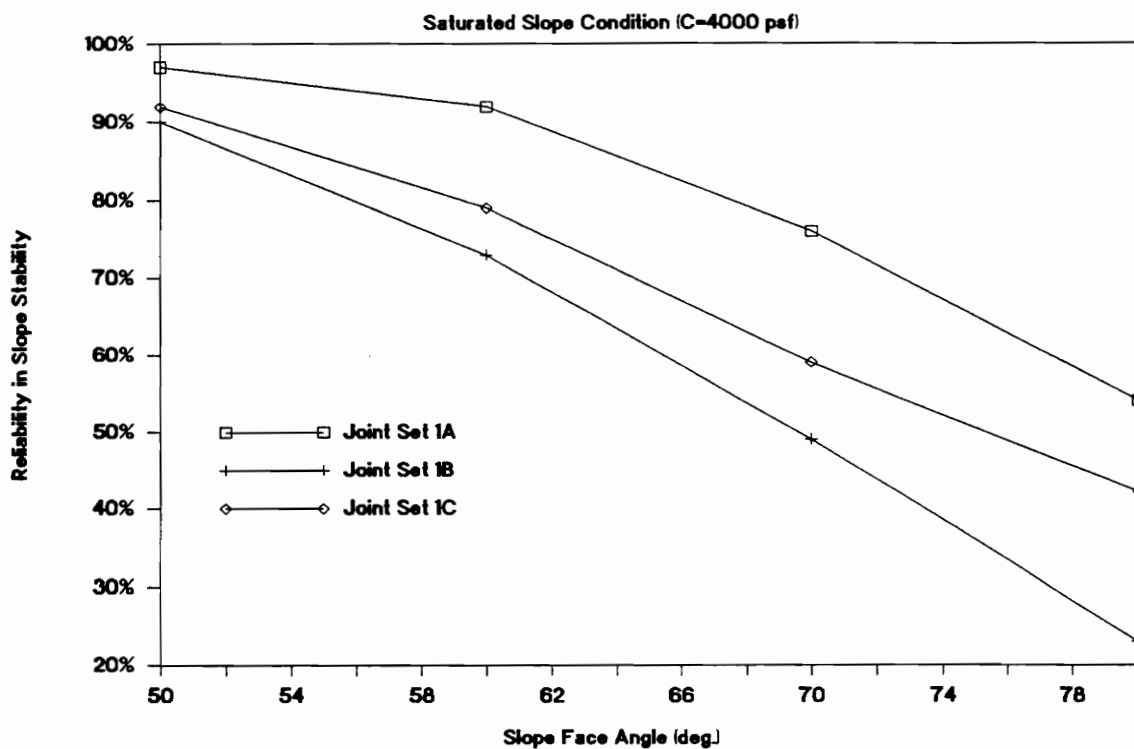

Figure 4.14 - Reliability Graph, Design Area 1, Saturated Conditions,  $c = 4000$  psf

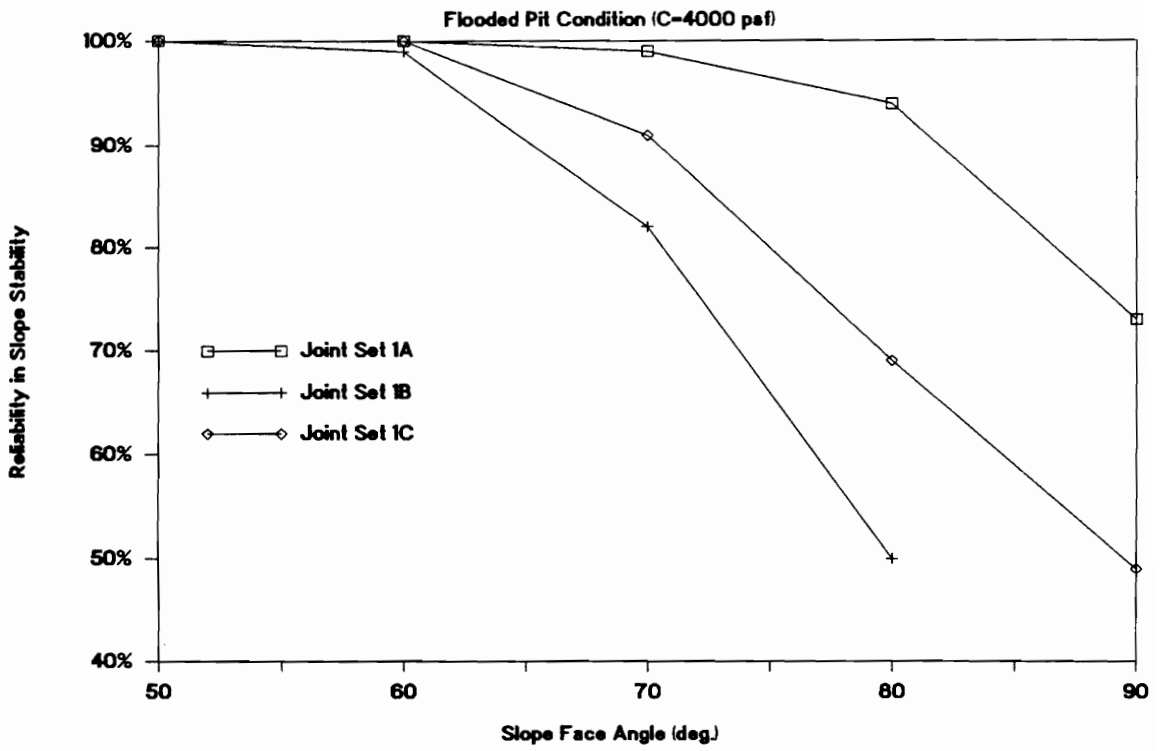

Figure 4.15 - Reliability Graph, Design Area 1, Flooded Pit Conditions, c = 4000 psf

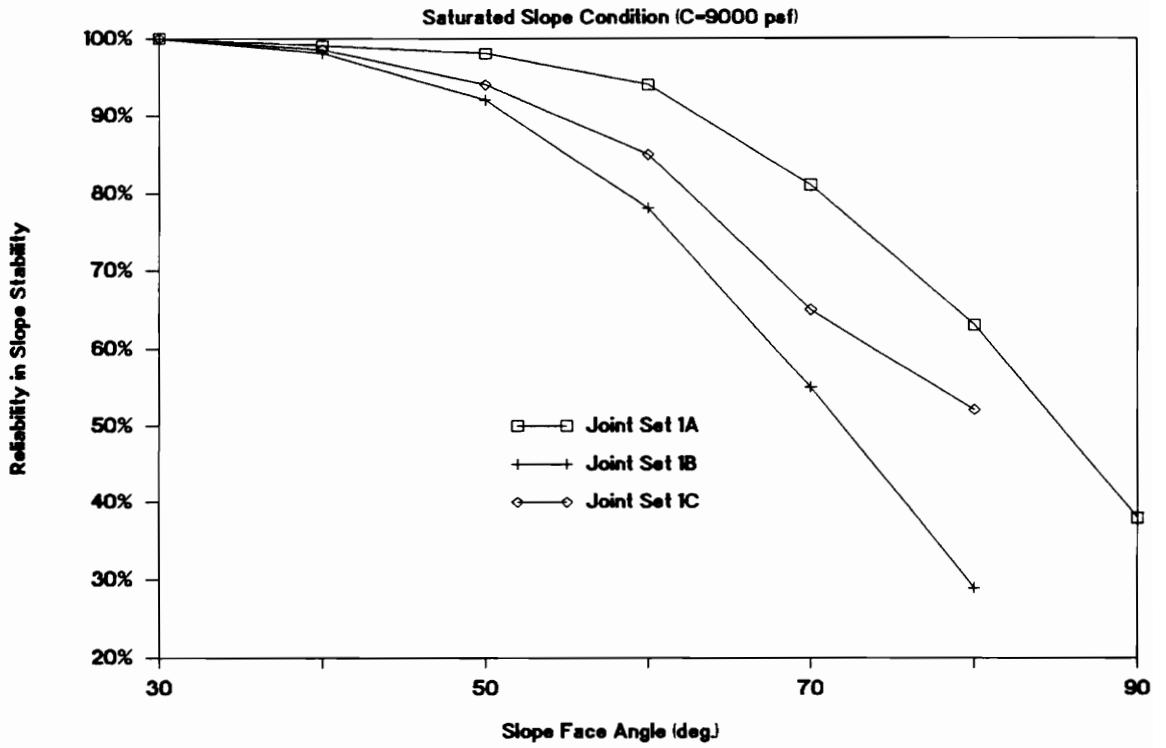

Figure 4.16 - Reliability Graph, Design Area 1, Saturated Conditions,  $c = 9000$  psf

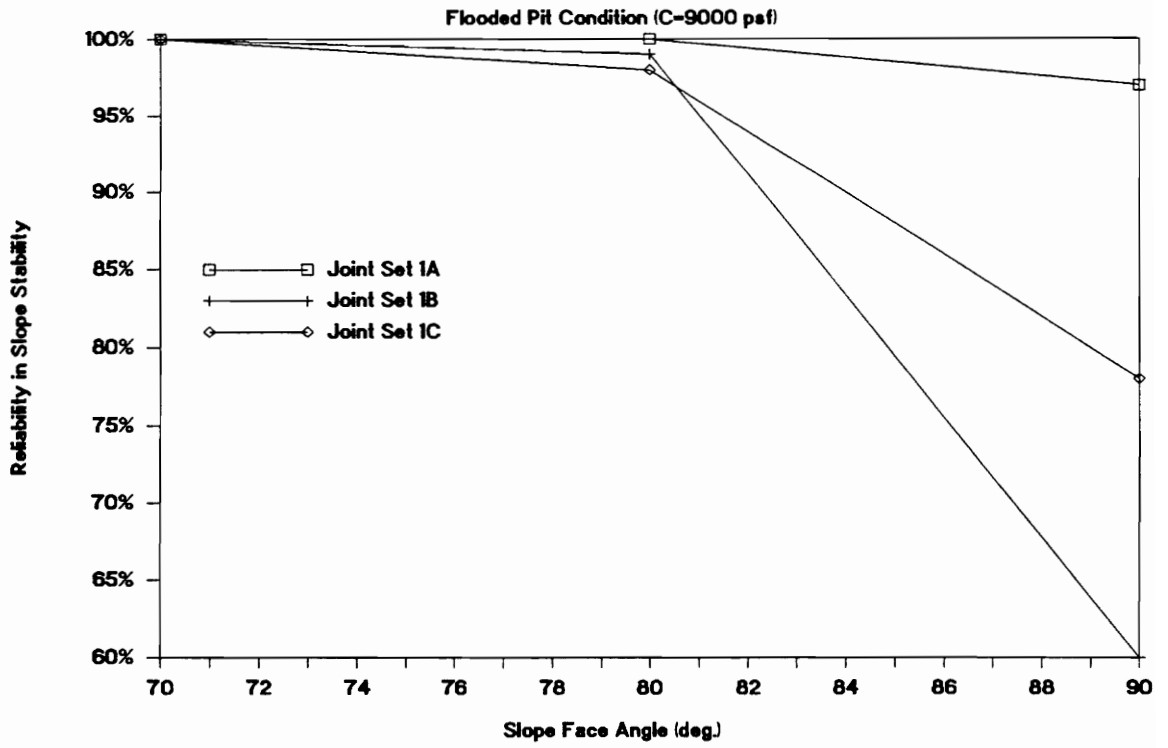

Figure 4.17 - Reliability Graph, Design Area 1, Flooded Pit Conditions, c = 9000 psf

Table 4.5 - Reliability Tables for c=4000 psf.

Reliability Slope condition	90 %		85 %		80 %		75%	
	flooded	saturated	flooded	saturated	flooded	saturated	flooded	saturated
(degrees)								
Design Area								
1	65	50	68	53	71	56	73	59
2	75	51	78	54	80	56	81	59
3	71	45	73	49	74	52	76	54
4	90	54	90	58	90	62	90	66
5	73	43	75	46	77	48	79	50
6	90	37	90	42	90	47	90	53
7	68	27	73	30	78	33	84	35
8	90	36	90	48	90	60	90	75
9	70	28	75	31	79	34	85	37
10 & 11	53	52	55	54	56	55	58	57

Table 4.6 - Reliability Tables for c=9000 psf.

Reliability Slope condition	90 %		85 %		80 %		75%	
	flooded	saturated	flooded	saturated	flooded	saturated	flooded	saturated
(degrees)								
Design Area								
1	82	51	84	55	85	59	86	61
2	90	51	90	55	90	59	90	61
3	90	48	90	51	90	54	90	57
4	90	67	90	72	90	77	90	84
5	90	44	90	47	90	50	90	52
6	90	70	90	80	90	90	90	90
7	90	27	90	49	90	70	90	80
8	90	70	90	80	90	90	90	90
9	90	30	90	52	90	73	90	82
10 & 11	64	62	67	64	69	65	71	66

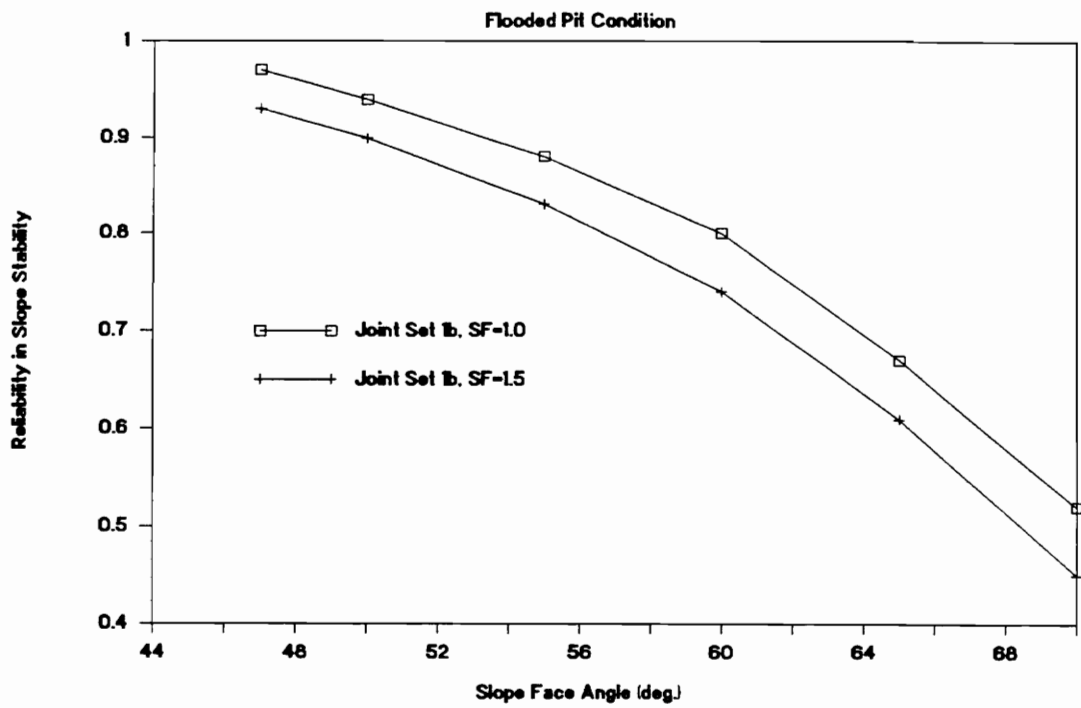

Figure 4.18 - Impact of Safety Factor on Reliability

stability was exhibited by either not forming critical wedges and/or yielding a high number of safety factors in the simulation. The highwall on the west side of the quarry above the 300 ft elevation averages approximately 130 ft.

The quarry is expected to fill with water to an elevation of approximately 300 ft above mean sea level at the south end of the quarry. Below the elevation of 300 ft, the submerged portion of the quarry will be supported by the weight of overlying water. On the west side of the quarry the water provides additional strength and increases stability.

The inherently unstable east wall is controlled by the bedding plane that dips into the quarry pit. Bedding planes and bedding plane discontinuity combinations (wedges) dipping into the pit from the east have the free surfaces required to initiate sliding and, consequently, exhibit lower stability. The east wall is destabilized to a lesser extent by the eastern run that contributes an uplifting force along critical discontinuities. However, this effect is generally canceled with filling of the pit to the 300 ft elevation. The highwall on the east side of the quarry above the 300 ft elevation averages approximately 30 ft.

The overall face angle design for long term stability may be accomplished with a variety of wall height and bench width combinations. In general, 85% reliability can be achieved for rock slopes in Design Areas 1 through 7 with a bench width to wall height ratio of one to one (50 ft horizontal benches and 50 ft vertical walls) for elevations above 300 ft. For elevations below 300 ft (flooded pit conditions), 85% reliability can be achieved with a bench width to wall height ratio of one to eight (25 ft horizontal benches and 200 ft vertical benches). Reliability of 85% can be achieved for rock slopes in Design Areas 8 through 11 with final walls that parallel the bedding plane. While the analysis shows that wall slope angles greater than the bedding plane are stable with good reliability, experience at the mine suggest paralleling the bedding "slick" gives the best measure of

stability. Mining experience with soil and weathered rock slopes suggest that stability can be achieved with a slope angle cut at two to one.

#### **4.16 Conclusions of Quarry Stability Evaluation**

From the results of this study, the following comments can be made regarding the ultimate highwall stability at the quarry :

i) Two structural regions and eleven discrete design areas were identified in the quarry, based on extensive structural field measurements.

ii) A range of cohesions between 2,500 and 18,000 psf were determined by back-analysis of stable slopes. Cohesions of zero, 4,000 psf, and 9,000 psf were used to determine reliability of the slope.

iii) Raveling, rotational, and toppling failures are not the mechanisms of major instability that can be expected at the quarry. Plane and wedge failures however, were determined to be the potential mechanisms of failure.

iv) Analytical evaluation of Wulff equal angle stereonet for each of the eleven design areas suggests that Design Areas 1 through 9 have potential for wedge failure. For Design Areas 10 and 11, potential for bedding plane failures appears to be more appropriate.

v) Numerical evaluation of all design areas, using the factor of safety concepts and Monte Carlo methods of the program PSLOPE, shows that, assuming a cohesion of 4,000 psf and a reliability of 85%, the critical slope angles range from 55 to 90 degrees for flooded conditions and from 30 to 58 degrees for saturated conditions.

vi) For design purposes, the final quarry may be subdivided into three combinations of conditions. The inherently stable west wall is controlled by the bedding plane that dips into the quarry wall and the 300 ft water level. The quarry is expected to

fill with water to an elevation of approximately 300 ft above mean sea level. Below the 300 ft elevation, the submerged portion of the quarry will be supported by the weight of overlying water. The inherently unstable east wall is controlled by the bedding plane that dips into the quarry pit. The east wall is destabilized to a lesser extent by water from the eastern tributary that contributes an uplifting force along critical discontinuities. However this effect is generally canceled with filling of the pit to the 300 ft elevation.

vii) The overall face angle design for long-term stability may be accomplished with a variety of wall height and bench width combinations as shown in Table 4.7. In general, 85% reliability can be achieved for rock slopes in Design Areas 1 through 7 with a bench width to wall height ratio of one to one (50 ft benches and 50 ft walls) for elevations above 300 ft and one to eight (25 ft benches and 200 ft benches) for elevations below 300 ft (flooded pit conditions). Reliability of 85% can be achieved for rock slopes in Design Areas 8 through 11 with final walls that parallel the bedding plane. Stability of soil and weathered rock slopes can be achieved with a slope angle cut at a run to rise ratio of two to one.

viii) Higher critical slope angles may be attained by assuming higher cohesion ( $c=9000$  psf) or lower reliability (90 or 80%). Reduction of the safety factor from 1.5 to 1.0 will also have an increasing impact on reliability.

ix) Qualification of the results from Design Areas 6, 7, 8, and 9 is necessary. These areas represent the undeveloped northeast portion of the mine where structural control is minimal. As these areas are developed, additional structural data will become accessible for more comprehensive evaluation. These areas may be re-evaluated when this information becomes available.

**Table 4.7 - Design Recommendations for Long-term  
Slope Stability at 85 % Reliability**

Design Area	Above Water Level Elevation 300 ft c = 4000 psf	Below Water Level Elevation 300 ft c = 9000 psf	Flooded
	Saturated  Highwall Dip angle (degrees)	Saturated  Highwall Dip angle (degrees)	Highwall Dip angle (degrees)
1	53	55	84
2	54	55	90
3	49	51	90
4	58	72	90
5	46	47	90
6	42	80	90
7	30 *	49	90
8	48 *	80	90
9	31 *	52	90
10	54 *	64	67
11	54 *	64	67

\* For design purposes, choose the smallest angle between the highwall dip angle or dip of bedding plane.

## **CHAPTER V. - CONCLUSIONS and RECOMMENDATIONS**

### **5.1 Conclusions**

Based on this research the following conclusions can be reached:

- i) Plane and wedge failures are the primary failure mechanisms in limestone and dolomite quarries. Rotational failure, raveling failure, and toppling failure are not mechanisms of large-scale failure in the carbonate quarries studied.
- ii) Slope stability problems are increasing in number and intensity for many rock quarries. Slope failures in excess of 600 feet are now a matter of record. As quarries penetrate deeper, the potential for slope failure increases.
- iii) Stable slope design should be incorporated into highwall design and development as mining progresses. Mine design is most successful when plans are developed at the mine by engineers and geologists most familiar with the changing geotechnical conditions of the slope.
- iv) PSLOPE provides a convenient, accurate and reproducible system for evaluating slope stability. The program permits both simple and complex analyses by deterministic and probabilistic techniques. Safety factors and "reliability in stability" are calculated with PSLOPE. A library of published geotechnical information assists the user in customizing the analysis. This information is accessed through help menus within the program.
- v) Due to the distributions of geotechnical values and the problems inherent in extrapolating data into the unmined area, the reliability approach has considerable merit over the use of a single safety factor. Reliability allows the use of all available data and minimizes geotechnical uncertainty.

vi) Back-analysis and sensitivity studies provide valuable insight into the effects of geotechnical variability on slope stability. Back-analysis of failed slopes permits detailed examination of any specific parameter. Sensitivity analysis reveals the effect of a range of values on slope stability.

## **5.2 Recommendations**

As quarries develop deeper in response to limited reserves and the difficulty of acquiring permits, mine personnel should closely monitor the stability of quarry highwalls. Evaluations of slope stability are most effective when performed by experienced personnel at the mine site.

To develop the skills necessary to assess highwall stability, mine personnel should use slope stability software such as PSLOPE to evaluate mine plans and highwall design. By measuring discontinuities, testing their strength, and comparing this information with observed conditions of the slope as mining progresses, a comprehensive understanding of slope stability may be obtained.

Additions and improvements to PSLOPE will increase its potential as an on-site evaluation tool. Improvements to PSLOPE may include information on the statistical distributions of the safety factors calculated under the reliability options. The graphing of safety factors, including a cumulative distribution curve, would be particularly useful. Additions to PSLOPE could include options for rotational and toppling failure. A sub-routine that addresses rock mass integrity would be a powerful complement to PSLOPE.

## REFERENCES

- Afrouz, A. A., 1992, *Practical Handbook of Rock Mass Classification Systems and Modes of Ground Failure*, CRC Press, Inc.
- Agterberg, F. P., 1961, "A Tectonics of the Crystalline Basement of the Dolomites in North Italy," Geologica Ultraject, No. 8, pp. 1-232.
- Barton, N. R., 1971, "A Model Study of the Behavior of Excavated Slopes," Ph.D. Thesis, University of London, Imperial College of Science and Technology.
- Barton, N. R., 1973, "Review of a New Strength Criterion for Rock Joints," Engineering Geology, Vol. 7, Elsevier, pp. 287-332.
- Barton, N. R., Lien, R., and Lunde, J., 1974, "Engineering Classification of Rock Masses for the Design of Tunnel Supports," Rock Mechanics, Vol. 6, pp. 189-236.
- Bedient, P. B., 1992, *Hydrology and Floodplain Analysis*, 2nd Edition, pp. 42-49.
- Bieniawski, Z.T., 1974, "Estimating the Strength of Rock Material," Journal of South African Institute Mining and Met., March, pp. 312-320.
- Brawner, C. O., 1968, "The Influence and Control of Groundwater in Open Pit Mining," Proceedings 5th Canadian Symposium on Rock Mechanics, Toronto.
- Call, R. D., 1972, "An Analysis of Geologic Structure for Open Pit Design," Ph.D Dissertation, Department of Mining and Geological Engineering, The University of Arizona, p. 42.
- Call, R. D., 1992, *SME Mining Engineering Handbook*, 2nd Edition, Vol. 1, Chapter 10, p. 881.
- CANMET, 1977, Pit Slope Manual, Supplement 5-1, Ottawa, Canada, Energy, Mines, and Resources, Canada, p. 41.
- Chowdhury, R. N., 1980, "Probabilistic Evaluation of Natural Slope Failures," Proceedings Int. Conf. on Protection from Natural Disasters, Asian Inst. Technology, Bangkok, pp. 605-615.

- Chowdhury, R. N., 1986, "Aspects of Geotechnical Reliability in Surface Mining," *Geotechnical Stability in Surface Mining, Proceedings*, International Symposium on Geotechnical Stability in Surface Mining, Calgary, p. 61.
- Chowdhury, R. N., 1987, "Risk of Slip Along Discontinuities in a Heterogeneous Medium," *Mining Science and Technology*, Vol. 4 pp. 241-255.
- Coates, D. F. and Grant, F., 1966, "Stress Measurements at Elliot Lake," *Canadian Institute Mining and Metallurgy Bull*, Vol. 59, pp. 603-613.
- Crowley, W. P., 1977, "Geologic Map of the Reisterstown Quadrangle, Maryland," USGS.
- Crowley, W. P. and Reinhardt, J., 1980, *Geologic Map of the Elliott City Quadrangle, Maryland*, USGS.
- Deere, D.V., 1967, "Design of Surface and Near Surface Construction in Rock and Breakage of Rock," *Proceedings*, 8th Symposium of Rock Mechanics., Fairhurst Canada, Ed., Am. Inst. Min. Eng., New York, pp. 237-302.
- Fairhurst, C., 1964, "On the Validity of the Brazilian Test for Brittle Materials," *International Journal Rock Mechanics and Mining Sciences*, Vol. 1, pp. 535-546.
- Fisher, R., 1953, "Dispersion on a Sphere," *Proceedings*. Royal Society, London, Ser. A, Vol. 217, pp. 295-305.
- Fraher, R. L., 1992, "Optimizing Roof Control Using Probabilistic Techniques in Roof Failure Prediction," Masters Thesis, Virginia Polytechnic Institute and State University.
- Franklin, J. A. and Dusseault, M.B., 1989, *Rock Engineering*, McGraw Hill Publishing Co., NY.
- Glass, C. E., 1982, "Influence of Earthquakes on Rock Slope Stability," *Proceedings*, 3rd International Conference on Stability in Surface Mining, SME-AIME, New York, pp. 89-112.
- Goodman, R. E., 1970, "The Deformability of Joints in Determination of the In-situ Modulus of Deformation of Rock," American Society for Testing Materials Special Technical Publication, Number 477, pp. 174-196.

- Greenland, B. J. and Knowles, J. D., 1970, "Environmental Considerations of Quarry Blasting," *The Quarry Manager's Journal: Institute of Quarrying Transactions*, Vol. 54, No. 10, pp. 371-381.
- Gumbel, E. J., 1958, *Statistics of Extremes*, Columbia University Press, New York.
- Hartman, H. L., 1987, *Introductory Mining Engineering*, New York: John Wiley.
- Haycocks, G., Zhou, Y., and Haycocks, C., 1992, "Long-Term Stability of Abandoned Quarry Highwalls," XIIth National Symposium on Mining, University of Kentucky, Lexington, September, pp. 43-48.
- Hoek, E. and Bray, J. W., 1991, *Rock Slope Engineering*, 3rd Edition. The Institute of Mining and Metallurgy, London, 358 pp.
- Hoek, E., Bray, J. W., Boyd, J. M., 1973, "The Stability of Rock Slope Containing a Wedge Resting on Two Intersecting Discontinuities," *Quarterly Journal of Geology*, Vol. 6, pp. 1-55.
- Horton R. E., 1933, "The Role of Infiltration in the Hydrologic Cycle," *Trans. Amer. Geophys. Union*, Vol. 14, pp. 446-460.
- Horton, R. E., 1940, "An Approach Towards a Physical Infiltration Capacity," *Proc. Soil Sci. Soc. Am.*, Vol. 5, pp. 399-417.
- Hubbert, M. K., and Rubey, W. W., 1959, "Role of Fluid Pressure in Mechanics of Overthrust Faulting," *Bull. Geol. Soc. Amer.*, Vol. 70, pp. 115-116.
- Huitt, J. L., 1956, "Fluid Flow in Simulated Fractures," *J.A.I. Ch. E.*, Vol. 2, pp. 259-264.
- John, K. W., 1962, "An Approach to Rock Mechanics," *Proceedings*, American Society of Civil Engineers, Vol. 88, No. SM4, Paper No. 5865, pp. 497-526.
- Kirsten, H. A. D., 1983, "Significance of the Probability of Failure in Slope Engineering," *The Civil Engineer in South Africa*, January.
- Landanyi, B. and Archambault, G., 1970, "Simulation of Shear Behavior in Jointed Rock Mass," *Proc. 11th Symposium on Rock Mechanics*, AIME, New York, pp. 105-125.
- Markland, J. T., 1972, "A Useful Technique for Estimating the Stability of Rock Slopes When the Rigid Wedge Sliding Type of Failure is Expected," *Imperial College Rock Mechanics Research Report No. 19*, pp. 10.

- McCracken, A. 1983, "Probabilistic Analysis of Slope Stability at a Large Quartzite Quarry," Steffen, Robertson and Kristen, Consulting Geotechnical Engineers, Johannesburg, South Africa.
- Merrill, R. H., 1973, "Stability of Slopes in Soil Rock," *SME Mining Engineering Handbook*, Vol. 1, p. 7-2.
- Morgenstern, N. R., 1971, "The Influence of Ground Water on Stability," Proc. 1st Symposium on Stability of Open Pit Mining, AIME, NY, pp. 68-70.
- Mueller, L. 1964, *Application of Rock Mechanics in the Design of Rock Slopes, in States of Stress in the Earth's Crust*, W. R. Judd, ed., American Elsevier Publishing Co., Inc., NY, pp. 595-596.
- Obert, L., 1973, *SME-Mining Engineering Handbook*, Vol. 1, Chapter 6, p.6-13.
- Patton, F. D., 1966, "Multiple Modes of Shear Failure in Rock," Proc. 1st International Congress of Rock Mechanics, Vol. 1, Lisbon, pp. 509-513.
- Piteau, D. R., and Jennings, J. E., 1970, "Slope Stability in Axial Symmetry," Proc. 5th Rock Mech. Symp., University of Minnesota, Pergamon Press, pp. 689-711.
- Roberts, D. and Hoek, E., 1971, "A Study of the Stability of a Disused Limestone Quarry Face in Mendip Hills, England," Proc. 2nd International Conference on Stability in Open Pit Mining, C. O. Brawner and V. Milligan (Ed.), pp. 239-256.
- Serafim, J. L. and Guerreiro, M., 1968, "Shear Strength of Rock Masses at the Three Spanish Dam Sites," Proc. Intl. Rock Mechanics Symposium, Madrid, pp.147-157.
- Stacey, T. R., 1968, "Stability of Rock Slopes in Open Pit Mines," Meg 737, Council for Scientific and Industrial Research, Pretoria, South Africa, p. 50.
- Steffen, O. K. H., 1982, "Monitoring of Rock Slopes," Proc. Conference of Southern African Surveyors, Johannesburg, South Africa.
- Tepordei, V. V., 1993, "Industrial Minerals 1992," Mining Engineering, June.
- Terzaghi, R. D., 1946, *Rock Defects and Loads on Tunnel Support and Rock Tunneling with Steel Supports*, The Commercial Shearing and Stamping Company, Youngstown, Ohio.

- Underwood, B. L., 1964, "Chalk Foundations at Four Major Dams in the Missouri River Basin," Trans. 8th International Congress on Large Dams, Vol. 1, Edinburgh, pp. 23-47.
- U.S. Department of the Army, 1977, "Recommended Guidelines for Safety Inspection of Dams," National Program Inspection of Nonfederal Dams, DAEN\_CWE Circular 1110-2-188, Office of the Chief of Engineers, Washington, D. C.
- Vanmarke, E., 1977, "Probabilistic Modeling in Soil Profiles," J. Geotech. Eng., ASCE, No. 103 (GT11), pp. 1247-1265.
- Vanmarke, E., 1977, "On the Reliability of Earth Slopes," J. Geotech. Eng., ASCE, No. 103 (GT11), pp. 1227-1246.
- Watson, G., 1966, "The Statistics of Orientation Data," Journal of Geology, Vol. 74, No. 5, Part 2, pp. 786-797.
- White, T., 1989, "Blasting to Specifications: Meeting the Requirements of the New Regulations," Quarry Management, December, pp. 27-34.
- Zienkiewicz, O. C., Mayer, P., and Cheung, Y. K., 1966, "Solution of Anisotropic Seepage by Finite Elements," Journal Eng. Mech. Div., ASCE, Vol. 92, EMI, pp. 111-120.

**APPENDIX A - Listing of PSLOPE Program Code**

## Global.bas

Global Const Pk = .017453293 'make adjustment for degrees from radians

=====

' Visual Basic global constant file. This file can be loaded into the  
' global module.

' Some constants are commented out because they have duplicates (for  
' example, NONE appears in several places).

=====

=====

' General '

=====

' Booleans

Global Const TRUE = -1

Global Const FALSE = 0

=====

' Event parameters '

=====

' Button and Shift (KeyDown, KeyUp, MouseDown, MouseMove, MouseUp)

Global Const SHIFT\_MASK = 1

Global Const CTRL\_MASK = 2

Global Const ALT\_MASK = 4

Global Const LEFT\_BUTTON = 1

Global Const RIGHT\_BUTTON = 2

Global Const MIDDLE\_BUTTON = 4

' ErrNum (LinkError)

Global Const WRONG\_FORMAT = 1

Global Const REQUEST\_WITHOUT\_INIT = 2  
 Global Const DDE\_WITHOUT\_INIT = 3  
 Global Const ADVISE\_WITHOUT\_INIT = 4  
 Global Const POKE\_WITHOUT\_INIT = 5  
 Global Const DDE\_SERVER\_CLOSED = 6  
 Global Const TOO\_MANY\_LINKS = 7  
 Global Const STRING\_TOO\_LONG = 8  
 Global Const INVALID\_CONTROL\_ARRAY\_REFERENCE = 9  
 Global Const UNEXPECTED\_DDE = 10  
 Global Const OUT\_OF\_MEMORY = 11  
 Global Const SERVER\_ATTEMPTED\_CLIENT\_OPERATION = 12

' KeyCode (KeyDown, KeyUp)

Global Const KEY\_LBUTTON = &H1  
 Global Const KEY\_RBUTTON = &H2  
 Global Const KEY\_CANCEL = &H3  
 Global Const KEY\_MBUTTON = &H4      ' NOT contiguous with L & RBUTTON  
 Global Const KEY\_BACK = &H8  
 Global Const KEY\_TAB = &H9  
 Global Const KEY\_CLEAR = &HC  
 Global Const KEY\_RETURN = &HD  
 Global Const KEY\_SHIFT = &H10  
 Global Const KEY\_CONTROL = &H11  
 Global Const KEY\_MENU = &H12  
 Global Const KEY\_PAUSE = &H13  
 Global Const KEY\_CAPITAL = &H14  
 Global Const KEY\_ESCAPE = &H1B  
 Global Const KEY\_SPACE = &H20  
 Global Const KEY\_PRIOR = &H21  
 Global Const KEY\_NEXT = &H22  
 Global Const KEY\_END = &H23  
 Global Const KEY\_HOME = &H24  
 Global Const KEY\_LEFT = &H25  
 Global Const KEY\_UP = &H26  
 Global Const KEY\_RIGHT = &H27  
 Global Const KEY\_DOWN = &H28  
 Global Const KEY\_SELECT = &H29  
 Global Const KEY\_PRINT = &H2A  
 Global Const KEY\_EXECUTE = &H2B  
 Global Const KEY\_SNAPSHOT = &H2C  
 Global Const KEY\_INSERT = &H2D  
 Global Const KEY\_DELETE = &H2E  
 Global Const KEY\_HELP = &H2F

' KEY\_A thru KEY\_Z are the same as their ASCII equivalents: 'A' thru 'Z'  
' KEY\_0 thru KEY\_9 are the same as their ASCII equivalents: '0' thru '9'

Global Const KEY\_NUMPAD0 = &H60  
Global Const KEY\_NUMPAD1 = &H61  
Global Const KEY\_NUMPAD2 = &H62  
Global Const KEY\_NUMPAD3 = &H63  
Global Const KEY\_NUMPAD4 = &H64  
Global Const KEY\_NUMPAD5 = &H65  
Global Const KEY\_NUMPAD6 = &H66  
Global Const KEY\_NUMPAD7 = &H67  
Global Const KEY\_NUMPAD8 = &H68  
Global Const KEY\_NUMPAD9 = &H69  
Global Const KEY\_MULTIPLY = &H6A  
Global Const KEY\_ADD = &H6B  
Global Const KEY\_SEPARATOR = &H6C  
Global Const KEY\_SUBTRACT = &H6D  
Global Const KEY\_DECIMAL = &H6E  
Global Const KEY\_DIVIDE = &H6F  
Global Const KEY\_F1 = &H70  
Global Const KEY\_F2 = &H71  
Global Const KEY\_F3 = &H72  
Global Const KEY\_F4 = &H73  
Global Const KEY\_F5 = &H74  
Global Const KEY\_F6 = &H75  
Global Const KEY\_F7 = &H76  
Global Const KEY\_F8 = &H77  
Global Const KEY\_F9 = &H78  
Global Const KEY\_F10 = &H79  
Global Const KEY\_F11 = &H7A  
Global Const KEY\_F12 = &H7B  
Global Const KEY\_F13 = &H7C  
Global Const KEY\_F14 = &H7D  
Global Const KEY\_F15 = &H7E  
Global Const KEY\_F16 = &H7F  
Global Const KEY\_NUMLOCK = &H90

' State (DragOver)

Global Const ENTER = 0  
Global Const LEAVE = 1  
Global Const OVER = 2

```
'====='  
,  
' Function parameters '  
,
```

' MsgBox parameters

```
Global Const MB_OK = 0          ' OK button only  
Global Const MB_OKCANCEL = 1    ' OK and Cancel buttons  
Global Const MB_ABORTRETRYIGNORE = 2 ' Abort, Retry, and Ignore buttons  
Global Const MB_YESNOCANCEL = 3  ' Yes, No, and Cancel buttons  
Global Const MB_YESNO = 4        ' Yes and No buttons  
Global Const MB_RETRYCANCEL = 5  ' Retry and Cancel buttons
```

```
Global Const MB_ICONSTOP = 16    ' Critical message  
Global Const MB_ICONQUESTION = 32 ' Warning query  
Global Const MB_ICONEXCLAMATION = 48 ' Warning message  
Global Const MB_ICONINFORMATION = 64 ' Information message
```

```
Global Const MB_DEFBUTTON1 = 0    ' First button is default  
Global Const MB_DEFBUTTON2 = 256  ' Second button is default  
Global Const MB_DEFBUTTON3 = 512  ' Third button is default
```

' MsgBox return values

```
Global Const IDOK = 1             ' OK button pressed  
Global Const IDCANCEL = 2         ' Cancel button pressed  
Global Const IDABORT = 3          ' Abort button pressed  
Global Const IDRETRY = 4          ' Retry button pressed  
Global Const IDIGNORE = 5         ' Ignore button pressed  
Global Const IDYES = 6            ' Yes button pressed  
Global Const IDNO = 7             ' No button pressed
```

```
'====='  
,  
' Method parameters '  
,
```

' Drag (controls)

```
Global Const CANCEL = 0  
Global Const BEGIN_DRAG = 1  
Global Const END_DRAG = 2
```

' GetData, GetFormat, SetData (Clipboard)

Global Const CF\_LINK = &HBF00

Global Const CF\_TEXT = 1

Global Const CF\_BITMAP = 2

Global Const CF\_METAFILE = 3

Global Const CF\_DIB = 8

' Show (form)

Global Const MODAL = 1

Global Const MODELESS = 0

=====

' Property values '

=====

' Alignment (label)

Global Const LEFT\_JUSTIFY = 0        ' 0 - Left Justify

Global Const RIGHT\_JUSTIFY = 1      ' 1 - Right Justify

Global Const CENTER = 2            ' 2 - Center

' BackColor, ForeColor, FillColor (standard RGB colors: form, controls)

Global Const BLACK = &H0&

Global Const RED = &HFF&

Global Const GREEN = &HFF00&

Global Const YELLOW = &HFFFF&

Global Const BLUE = &HFF0000

Global Const MAGENTA = &HFF00FF

Global Const CYAN = &HFFFF00

Global Const WHITE = &HFFFFFF

' BackColor, ForeColor, FillColor (system colors: form, controls)

Global Const SCROLL\_BARS = &H80000000        ' Scroll-bars gray area.

Global Const DESKTOP = &H80000001            ' Desktop.

Global Const ACTIVE\_TITLE\_BAR = &H80000002    ' Active window caption.

Global Const INACTIVE\_TITLE\_BAR = &H80000003   ' Inactive window caption.

Global Const MENU\_BAR = &H80000004          ' Menu background.

Global Const WINDOW\_BACKGROUND = &H80000005   ' Window background.

Global Const WINDOW\_FRAME = &H80000006       ' Window frame.

Global Const MENU\_TEXT = &H80000007        ' Text in menus.

Global Const WINDOW\_TEXT = &H80000008      ' Text in windows.

Global Const TITLE\_BAR\_TEXT = &H80000009 ' Text in caption, size box, scroll-  
bar arrow box..

Global Const ACTIVE\_BORDER = &H8000000A ' Active window border.

Global Const INACTIVE\_BORDER = &H8000000B ' Inactive window border.

Global Const APPLICATION\_WORKSPACE = &H8000000C ' Background color of  
multiple document interface (MDI) applications.

Global Const HIGHLIGHT = &H8000000D ' Items selected item in a control.

Global Const HIGHLIGHT\_TEXT = &H8000000E ' Text of item selected in a  
control.

Global Const BUTTON\_FACE = &H8000000F ' Face shading on command  
buttons.

Global Const BUTTON\_SHADOW = &H80000010 ' Edge shading on command  
buttons.

Global Const GRAY\_TEXT = &H80000011 ' Grayed (disabled) text. This color  
is set to 0 if the current display driver does not support a solid gray color.

Global Const BUTTON\_TEXT = &H80000012 ' Text on push buttons.

' BorderStyle (form, label, Picture box, text box)

Global Const NONE = 0 ' 0 - None

Global Const FIXED\_SINGLE = 1 ' 1 - Fixed Single

Global Const SIZABLE = 2 ' 2 - Sizable (Forms only)

Global Const FIXED\_DOUBLE = 3 ' 3 - Fixed Double (Forms only)

' DragMode (controls)

Global Const MANUAL = 0 ' 0 - Manual

Global Const AUTOMATIC = 1 ' 1 - Automatic

' DrawMode (form, Picture box, Printer)

Global Const BLACKNESS = 1 ' 1 - Blackness

Global Const NOT\_MERGE\_PEN = 2 ' 2 - Not Merge Pen

Global Const MASK\_NOT\_PEN = 3 ' 3 - Mask Not Pen

Global Const NOT\_COPY\_PEN = 4 ' 4 - Not Copy Pen

Global Const MASK\_PEN\_NOT = 5 ' 5 - Mask Pen Not

Global Const INVERT = 6 ' 6 - Invert

Global Const XOR\_PEN = 7 ' 7 - Xor Pen

Global Const NOT\_MASK\_PEN = 8 ' 8 - Not Mask Pen

Global Const MASK\_PEN = 9 ' 9 - Mask Pen

Global Const NOT\_XOR\_PEN = 10 ' 10 - Not Xor Pen

Global Const NOP = 11 ' 11 - Nop

Global Const MERGE\_NOT\_PEN = 12 ' 12 - Merge Not Pen

Global Const COPY\_PEN = 13 ' 13 - Copy Pen

Global Const MERGE\_PEN\_NOT = 14 ' 14 - Merge Pen Not

Global Const MERGE\_PEN = 15 ' 15 - Merge Pen

Global Const WHITENESS = 16        ' 16 - Whiteness

' DrawStyle (form, Picture box, Printer)

Global Const SOLID = 0            ' 0 - Solid

Global Const DASH = 1            ' 1 - Dash

Global Const DOT = 2            ' 2 - Dot

Global Const DASH\_DOT = 3        ' 3 - Dash-Dot

Global Const DASH\_DOT\_DOT = 4    ' 4 - Dash-Dot-Dot

Global Const INVISIBLE = 5       ' 5 - Invisible

Global Const INSIDE\_SOLID = 6    ' 6 - Inside Solid

' FillStyle (form, Picture box, Printer)

' Global Const SOLID = 0          ' 0 - Solid

Global Const TRANSPARENT = 1     ' 1 - Transparent

Global Const HORIZONTAL\_LINE = 2 ' 2 - Horizontal Line

Global Const VERTICAL\_LINE = 3   ' 3 - Vertical Line

Global Const UPWARD\_DIAGONAL = 4 ' 4 - Upward Diagonal

Global Const DOWNWARD\_DIAGONAL = 5 ' 5 - Downward Diagonal

Global Const CROSS = 6           ' 6 - Cross

Global Const DIAGONAL\_CROSS = 7 ' 7 - Diagonal Cross

' LinkMode (controls)

' Global Const NONE = 0           ' 0 - None

Global Const HOT = 1            ' 1 - Hot

Global Const COLD = 2           ' 2 - Cold

' LinkMode (form)

' Global Const NONE = 0           ' 0 - None

Global Const SERVER = 1        ' 1 - Server

' MousePointer (form, controls)

Global Const DEFAULT = 0        ' 0 - Default

Global Const ARROW = 1          ' 1 - Arrow

Global Const CROSSHAIR = 2      ' 2 - Cross

Global Const IBEAM = 3          ' 3 - I-Beam

Global Const ICON\_POINTER = 4    ' 4 - Icon

Global Const SIZE\_POINTER = 5    ' 5 - Size

Global Const SIZE\_NE\_SW = 6     ' 6 - Size NE SW

Global Const SIZE\_N\_S = 7       ' 7 - Size N S

Global Const SIZE\_NW\_SE = 8     ' 8 - Size NW SE

Global Const SIZE\_W\_E = 9       ' 9 - Size W E

Global Const UP\_ARROW = 10      ' 10 - Up Arrow

Global Const HOURGLASS = 11    ' 11 - Hourglass

```

Global Const NO_DROP = 12      ' 12 - No drop

' ScaleMode (form, Picture box, Printer)
Global Const USER = 0         ' 0 - User
Global Const TWIPS = 1        ' 1 - Twip
Global Const POINTS = 2       ' 2 - Point
Global Const PIXELS = 3       ' 3 - Pixel
Global Const CHARACTERS = 4    ' 4 - Character
Global Const INCHES = 5       ' 5 - Inch
Global Const MILLIMETERS = 6   ' 6 - Millimeter
Global Const CENTIMETERS = 7   ' 7 - Centimeter

' ScrollBar (text box)
' Global Const NONE = 0        ' 0 - None
Global Const HORIZONTAL = 1    ' 1 - Horizontal
Global Const VERTICAL = 2      ' 2 - Vertical
Global Const BOTH = 3         ' 3 - Both

' Value (check box)
Global Const UNCHECKED = 0     ' 0 - Unchecked
Global Const CHECKED = 1      ' 1 - Checked
Global Const GRAYED = 2       ' 2 - Grayed

' WindowState (form)
Global Const NORMAL = 0       ' 0 - Normal
Global Const MINIMIZED = 1    ' 1 - Minimized
Global Const MAXIMIZED = 2    ' 2 - Maximized

```

---

```

'from ; Microsoft Visual Basic Programmer's Guide page 323
'
'

```

```

'Constants to represent the file access modes.

```

```

Global Const SAVEFILE = 1, LOADFILE = 2
Global Const REPLACEFILE = 1, READFILE = 2, ADDTOFILE = 3
Global Const RANDOMFILE = 4, BINARYFILE = 5

```

```

'Constants to represent error conditions.

```

```

Global Const Err_DeviceUnavailble = 68
Global Const Err_DiskNotReady = 71, Err_FileAlreadyExist = 58
Global Const Err_TooManyFiles = 67, Err_RenameAcrossDisk = 74
Global Const Err_Path_FileAccessError = 75, Err_DeviceIO = 57

```

Global Const Err\_DiskFull = 61, Err\_BadFileName = 64  
 Global Const Err\_BadFileNameOrNumber = 52, Err\_FileNotFound = 53  
 Global Const Err\_PathDoesNotExist = 76, Err\_BadFileMode = 54  
 Global Const Err\_FileAlreadyOpen = 55, Err\_InputPastEndOfFile = 62

Global Const MB\_EXCLAIM = 48, MB\_STOP = 16  
 Global WorkingFileName As String 'Path and filename in form.

### Module1.bas

Function FileOpener (NameToUse\$, Mode%, RecordLen%) As Integer

'from ; Microsoft Visual Basic Programmer's Guide page 319

'Opens a file in specified access mode.

'Arguments: NameToUse\$ - String representing a valid OS filename.

' Mode% - Integer representing file-access mode.

' RecordLen% - Integer specifying length of one record

'Returns : Integer by which the file can be specified in the program;

' return is zero if Open fails.

Const REPLACEFILE = 1, READFILE = 2, ADDTOFILE = 3

Const RANDOMFILE = 4, BINARYFILE = 5

FileNum% = FreeFile 'Get the integer identifier from OS

On Error GoTo OpenerError 'Prepare for possible error.

Select Case Mode

Case REPLACEFILE 'Sequential output.

Open NameToUse For Output As FileNum%

Case READFILE 'Sequential input.

Open NameToUse For Input As FileNum%

Case ADDTOFILE 'Sequential append

Open NameToUse For Append As FileNum%

Case RANDOMFILE 'Random access.

Open NameToUse For Random As FileNum% Len = RecordLen%

Case BINARYFILE 'Binary access.

Open NameToUse For Binary As FileNum%

Case Else

Exit Function

End Select

FileOpener = FileNum% 'Return the file number.

Exit Function

OpenerError:

Action% = FileErrors(Err)

Select Case Action%

Case 0

```

    Resume
    'You needn't specify Case1 or Case 2 since Case Else uses same response.
Case Else
    FileOpener = 0    'Tell caller Open failed
    Exit Function
End Select
End Function

```

Function FileErrors (errVal As Integer) As Integer  
'from : Microsoft Visual Basic Programmers Guide page 289.

Return Value	Meaning	Return Value	Meaning
'0	Resume	2	Unrecoverable error
'1	Resume Next	3	Unrecognized error

msgType% = MB\_OK 'Defined in CONSTANT.TXT

```

Select Case errVal
    Case Err_DeviceUnavailble 'Error #68
        Msg$ = "That device appears unavailable."
        msgType% = MB_OK
    Case Err_DiskNotReady     'Error #71
        Msg$ = "Incert a disk in the drive and close the door."
    Case Err_DeviceIO        'Error #57
        Msg$ = "Internal disk error."
        msgType% = MB_OK
    Case Err_DiskFull        'Error #61
        Msg$ = "Disk is full. Continue?"
        msgType% = 35
    Case Err_BadFileName, Err_BadFileNameOrNumber 'Errors #64 & #52
        Msg$ = "That filename is illegal."
    Case Err_PathDoesNotExist          'Error #76
        Msg$ = "That path doesn't exist"
    Case Err_BadFileMode                'Error #54
        Msg$ = "Can't open your file for that type access."
    Case Err_FileAlreadyOpen           'Error #55
        Msg$ = "This file is already open."
    Case Err_InputPastEndOfFile        'Error #62
        Msg$ = "This file has a nonstandard end-of-file marker,"
        Msg$ = Msg$ + "or an attempt has been made to read beyond"
        Msg$ = Msg$ + "the end of the file."
    Case Else
        FileErrors = 3
        Exit Function
End Select
response% = MsgBox(Msg$, msgType%, "Disk Error")

```

```

Select Case response%
    Case 1, 4      'OK, Retry buttons.
        FileErrors = 2
    Case 5        'Ignore button
        FileErrors = 1
    Case 2, 3     'Cancel, ignore button
        FileErrors = 2
    Case Else
        FileErrors = 3
End Select
End Function

```

Function ConfirmFile (TheName As String, Operation As Integer) As Integer  
 'from : Microsoft Visual Basic Programmer's Guide page 290-291

'Parameters:

```

' TheName    Filespec to be checked for and confirmed.
' Operation   Code for sequential file access mode (Output, Input, etc.)
'             Note procedure works for binary and random because messages are
'             conditioned on Operation being <> to certain sequential modes.

```

'Returns:

```

'1           Confirms operation will not cause a problem
'0           Users decided not to go through with the operation.

```

NL\$ = Chr\$(13) + Chr\$(10) 'Carriage return-Linefeed combination.

On Error GoTo ConfirmFileError 'Turn on the error trap.

TheFile\$ = Dir\$(TheName) 'See if the file exist.

On Error GoTo 0 'Turn error trap off.

'If user is saving text file that already exist ....

If TheFile\$ <> "" And Operation = REPLACEFILE Then

```

    Msg$ = "The file " + TheName$ + " already exist on disk." + NL$
    Msg$ = Msg$ + "Saving the text box contents to that file will" + NL$
    Msg$ = Msg$ + "destroy the file's current contents, replacing" + NL$
    Msg$ = Msg$ + "them with the text from the text box." + NL$ + NL$
    Msg$ = Msg$ + "Choose OK to overwrite the file, Cancel to stop." + NL$
    Confirmation% = MsgBox(Msg$, 65, "File Message")

```

'If user wants to load text from nonexistant file...

ElseIf TheFile\$ = "" And Operation = READFILE Then

```

    Msg$ = "The file " + TheName + " doesn't exist." + NL$
    Msg$ = Msg$ + "Would you like to create and then edit it ?" + NL$ + NL$
    Msg$ = Msg$ + "Choose OK to create the file and Cancel to stop."
    Confirmation% = MsgBox(Msg$, 65, "File Message")
    'If TheFile$ doesn't exist, force procedure to return
    '0 by setting Confirmation% = 2

```

```

ElseIf TheFile$ = "" Then
    If Operation = RANDOMFILE Or Operation = BINARYFILE Then
        Confirmation% = 2
    End If
    'If the file exist & operation isn't successful,
    'Confirmation = 0 & procedure returns 1.
    End If
'If no box was displayed, Confirmation% = 0; if user chose OK
'in either case , Confirmation% = 1 and ConFirmFile should return 1,
'to confirm that the intended operation is OK. If Confirmation % > 1
'ConfirmFile should return 0, because user doesn't want to go through with the
operation...
If Confirmation% > 1 Then ConfirmFile = 0 Else ConfirmFile = 1
    If Confirmation% = 1 Then
        If Operation = LOADFILE Then 'User wants to create the file. So assign
            Operation = REPLACEFILE 'REPLACEFILE to Operation so caller will
        End If 'understand action to be taken. Return code
    End If 'confirming desire to either overwrite existing
        'file or create new file.

Exit Function
ConfirmFileError:
Action% = FileErrors(Err)
    Select Case Action%
        Case 0
            Resume
        Case 1
            Resume Next
        Case 2
            Exit Function
        Case Else
            Error Err
    End Select
End Function

Sub GetName (LoadOrSave As String)
    'Get the file name from the user.
    NameToUse$ = InputBox$(LoadOrSave, "File name", WorkingFileName)
    'Convert the name to upper case letters for consistent appearance.
    WorkingFileName = LTrim$(RTrim$(UCase$(NameToUse$)))
End Sub

Sub Overwrite (TheBox As Control)

```

```
If ConfirmFile((WorkingFileName), REPLACEFILE) Then
'If the file exists, call FileOpener to open it, then place the text
'as is in the file and close the file.
```

```
FileNum% = FileOpener((WorkingFileName), REPLACEFILE, 0)
If FileNum% = 0 Then Exit Sub
On Error GoTo WriteError
Print #FileNum%, TheBox.Text
Close FileNum%
End If
Exit Sub
```

```
WriteError:
```

```
Action% = FileErrors(Err) 'If there was an error accessing the file,
Select Case Action% 'find out what to do, then do it
Case 0
Resume 'Try the statement that failed again.
Case 1
Resume Next 'Forget the statement that failed; just
Case 2 'go ahead and do the rest of procedure.
Exit Sub 'Exit the sub procedure right away.
Case Else
Error Err 'If the error is completely unaanticipated.
End 'Display system error message, then quit.
End Select
End Sub
```

## Module2.bas

```
Sub CheckItOut (TheTextBox As Control)
```

```
'Microsoft Visual Basic Programmer's Guide page 324
If TheTextBox.Text <> "" Then 'If box contains text,
Msg$ = "Do you want to save this text ?" 'find out if it should
Answer% = MsgBox(Msg$, 52, "Hey!") 'be saved
If Answer% = 6 Then 'If user answers OK
GetName ("Save AS:") 'get a file name
Call Overwrite(TheTextBox) 'and overwrite the file.
ElseIf Answer% = 7 Then 'If not adjust caption...
Form25.SaveButton.Caption = "Save/New File"
Close '...then close all files
End If
TheTextBox.Text = "" 'empty the text box
Form25.Caption = "Text Editor" 'Reset the title bar
End If
```

End Sub

## **Front2.frm**

Sub Exitout\_Click ()

End

End Sub

Sub plane\_Click ()

Form2.Show

Form1.Hide

End Sub

Sub wedge\_Click ()

Form3.Show

Form1.Hide

End Sub

Sub planeprob\_Click ()

End Sub

Sub planprob\_Click ()

Form4.Show

End Sub

Sub reliaplane\_Click ()

Form4.Show

Form1.Hide

End Sub

Sub reliawedge\_Click ()

Form5.Show

Form1.Hide

End Sub

Sub Help\_Click ()

Form7.Show

Form1.Hide

End Sub

Sub Command1\_Click ()

```
Form1.Hide
form25.Show
End Sub
```

### **Editor.frm**

```
Sub ExitButton_Click ()
'Microsoft Visual Basic Programmer's Guide page 323.
'Call procedure to ensure text in the box won't be lost
CheckItOut FileTextBox
Form25.Hide
Form1.Show
End Sub
```

```
Sub Form_Load ()
CurrentX = 100: CurrentY = 100 'Position the form on desktop.
Form25.Caption = "Text Editor"
BoxCaption$ = "Using" + Form25.Caption
NL$ = Chr$(13) + Chr$(10) 'combination needed for line breaks
'Display a message telling the user how to start the editor.
Msg$ = "If you want to create a new text file,"
Msg$ = Msg$ + NL$ + "choose OK, type in your text, and then "
Msg$ = Msg$ + NL$ + "choose Save/New File."
Msg$ = Msg$ + NL$ + NL$ + "To open a file that already exist on disk, "
Msg$ = Msg$ + NL$ + "choose OK, choose the Open File button, "
Msg$ = Msg$ + " and type the name of the file you want to open."
MsgBox Msg$, 64, BoxCaption$
End Sub
```

```
Sub SaveButton_Click ()
'First check whether the button is currently being used for saving
'text, or for clearing it. If it's caption is "Save/New File", then
'save FileTextBox.Text. Otherwise ask if the text should be saved,
'do as instructed, then clear FileTextBox.text by assigning "".
If SaveButton.Caption = "Save/New File" Then
    GetName ("Save As:") 'Query the user for file name.
```

```
If WorkingFileName = "" Then
```

```
    Msg$ = "You didn't enter a file name" 'any filename at all.
    MsgBox Msg$
```

```
Exit Sub
End If          'then just stop trying.
```

```
Call Overwrite(FileTextBox)      'Overwrite the file name
SaveButton.Caption = "New/Save File" 'with new text
Else
    'If the button is being used to clear the text box for new
    'text, call CheckItOut to see if old text should be saved.
    CheckItOut FileTextBox
    SaveButton.Caption = "Save/New File" 'Reset button caption.
End If
End Sub
```

```
Sub OpenButton_Click ()
    CheckItOut FileTextBox      'See if there is text to be saved.
    GetName ("File To Open:")
    If WorkingFileName <> "" Then
        OpenMode% = LOADFILE
        If ConfirmFile(WorkingFileName, OpenMode%) = 1 Then 'If file exist,
            FileNum% = FileOpener(WorkingFileName, OpenMode%, 0) 'try to open.
            If FileNum% = 0 Then Exit Sub          'If open fails
            If OpenMode% = ReplaceFile Then      'just exit; if
                Close FileNum%                  'OpenMode was set
                Exit Sub                          'to replace file it is
            End If                                'empty, so you can
        Else                                     'close it and exit.
            Exit Sub                              'If the file still doesn't exist...
        End If
    Else                                         '...or if the user failed to enter
        Msg$ = "You didn't enter a file name" 'any filename at all.
        MsgBox Msg$
        Exit Sub
    End If          'then just stop trying.
```

'Several statements in this procedure use file numbers as arguments.  
'so turn on an error trap and leave it on for the remainder of procedure.  
On Error GoTo ReadError  
'If the files text won't fit comfortably into the text box, then exit.  
If LOF(FileNum%) > 60000 Then  
 Msg\$ = "Sorry your file is too large to edit."

```

    MsgBox Msg$, 16, "File Too Big"
    Exit Sub
End If
'Otherwise, read one line at a time into a variable.
Do Until EOF(FileNum%)
    Line Input #FileNum%, NextLine$
    'As each line is read, add it those preceding it, then
    'replace the terminator (Line Input # drops the line-break
    'characters so you have to add them back).
    LineFromFile$ = LineFromFile$ + NextLine$ + Chr$(13) + Chr$(10)
Loop

'Put the file contents into the text box.
FileTextBox.Text = LineFromFile$
'Change title bar to indicate file being edited.
Form25.Caption = "Text Editor Now Editing: " + WorkingFileName
'Change caption on Save/New File button so it can be used
'to clear current text from the text box.
SaveButton.Caption = "New/Save File"
'Once text is read in, close the file.
Close FileNum%
Exit Sub

ReadError:
Action% = FileErrors(Err)
Select Case Action%
    Case 0
        Resume
    Case 1
        Resume Next
    Case 2
        Exit Sub
End Select
End Sub

```

### **Planin2.frm**

```

Sub planecmd_Click ()
    'Input from Form2
    Face = Val(Faceangle.Text)
    C = Val(Cohesion.Text)
    H = Val(Vertical.Text)

```

```
Discon = Val(Discontinuity.Text)
Phi = Val(friction.Text)
gamma = Val(Density.Text)
Waterfilled = Val(Waterpercent.Text) / 100
Crackdistance = Val(Distance.Text)
densitywater = Val(Weightwater.Text)
```

```
'trap cohesion errors
```

```
Msg$ = "Check the cohesion input."
```

```
  If C < 0 Then
```

```
    MsgBox Msg$
```

```
    SafetyFactor.Text = Format$(SF, " ")
```

```
    Exit Sub
```

```
  End If
```

```
'trap face angle errors
```

```
Msg$ = "Check the face angle input. "
```

```
  If Face > 90 Or Face <= 0 Then
```

```
    MsgBox Msg$
```

```
    SafetyFactor.Text = Format$(SF, " ")
```

```
    Exit Sub
```

```
  End If
```

```
'trap friction angle input errors
```

```
Msg$ = "Check the friction angle input."
```

```
  If Phi > 70 Or Phi < 0 Then
```

```
    MsgBox Msg$
```

```
    SafetyFactor.Text = Format$(SF, " ")
```

```
    Exit Sub
```

```
  End If
```

```
'trap discontinuity dip input errors
```

```
Msg$ = "Check the discontinuity dip input. "
```

```
  If Discon > 89.999 Or Discon <= 0 Then
```

```
    MsgBox Msg$
```

```
    SafetyFactor.Text = Format$(SF, " ")
```

```
    Exit Sub
```

```
  End If
```

```
  Msg$ = " The dip of the face angle must be greater than the dip of the  
discontinuity."
```

```

If Discon >= Face Then
  MsgBox Msg$
  SafetyFactor.Text = Format$(SF, " ")
  Exit Sub
End If

```

Msg\$ = "Check 'portion of tension crack filled with water' input. Be sure to enter a value in percent."

```

If Waterfilled > 100 Or Waterfilled < 0 Then
  MsgBox Msg$
  SafetyFactor.Text = Format$(SF, " ")
  Exit Sub
End If

```

```

'trap height errors
Msg$ = "Check the height input."
If H < 0 Then
  MsgBox Msg$
  SafetyFactor.Text = Format$(SF, " ")
  Exit Sub
End If

```

```

'trap rock density errors
Msg$ = "Check the rock density input."
If gamma < 0 Then
  MsgBox Msg$
  SafetyFactor.Text = Format$(SF, " ")
  Exit Sub
End If

```

```

'trap water density errors
Msg$ = "Check the water density input."
If densitywater < 0 Then
  MsgBox Msg$
  SafetyFactor.Text = Format$(SF, " ")
  Exit Sub
End If

```

$$LLP = H / \sin(\text{Discon} * \text{Pk})$$

```

LLF = H / Sin(Face * Pk)
Theda = Face - Discon
DDA = Sqr(LLP ^ 2 + LLF ^ 2 - (2 * LLP * LLF * Cos(Theda * Pk)))

```

```

If Crackdistance > DDA Or Crackdistance <= 0 Then
    Msg$ = "Check the distance to tension crack input."
    MsgBox Msg$
    SafetyFactor.Text = Format$(SF, " ")
    Exit Sub
End If

```

```

DDZ = DDA - Crackdistance
Z = DDZ * Tan(Discon * Pk)
Zw = Waterfilled * Z

```

```

W = .5 * gamma * H ^ 2 * (((1 - (Z / H) ^ 2) / Tan(Discon * Pk)) - 1 / Tan(Face *
Pk))
A = (H - Z) / Sin(Discon * Pk)
U = (.5 * (densitywater) * Zw * (H - Z)) * (1 / Sin(Discon * Pk))'Hydrologic uplift
V = .5 * (densitywater) * Zw ^ 2 'Hydrologic push-out
ResistingF = (C * A) + (W * Cos(Discon * Pk) - U - V * Sin(Discon * Pk)) *
Tan(Phi * Pk)
SlidingF = W * Sin(Discon * Pk) + V * Cos(Discon * Pk)
SF = ResistingF / SlidingF
SafetyFactor.Text = Format$(SF, "##0.00")

```

```
End Sub
```

```

Sub planexit_Click ()
    Form2.Hide
    Form1.Show
End Sub

```

```

Sub planeprint_Click ()
    PrintForm
End Sub

```

```

Sub Command1_Click ()
    Form8.Show
    Form2.Hide
End Sub

```

## Wedgein.frm

```
Sub planexit_Click ()  
Form2.Hide  
Form1.Show  
End Sub
```

```
Sub wedgcmd_Click ()
```

```
    H = Val(Vertical.Text)  
    gamma = Val(Density.Text)  
    N = Val(Overhang.Text)
```

```
    Alpha1 = Val(Direction1.Text)  
    Si1 = Val(Magnitude1.Text)  
    Phi1 = Val(Friction1.Text)  
    C1 = Val(Cohesion1.Text)  
    U1 = Val(Water1.Text)
```

```
    Alpha2 = Val(Direction2.Text)  
    Si2 = Val(Magnitude2.Text)  
    Phi2 = Val(Friction2.Text)  
    C2 = Val(Cohesion2.Text)  
    U2 = Val(Water2.Text)
```

```
    Alpha3 = Val(Direction3.Text)  
    Si3 = Val(Magnitude3.Text)
```

```
    Alpha4 = Val(Direction4.Text)  
    Si4 = Val(Magnitude4.Text)
```

```
'trap cohesion errors
```

```
Msg$ = "Check the cohesion input."
```

```
    If C1 < 0 Then
```

```
        MsgBox Msg$
```

```
        SafetyFactor.Text = Format$(SF, " ")
```

```
        Exit Sub
```

```
    End If
```

```
    If C2 < 0 Then
```

```
        MsgBox Msg$
```

```
        SafetyFactor.Text = Format$(SF, " ")
```

```
Exit Sub
End If
```

```
'trap face angle errors
Msg$ = "Check the face angle input. "
If Si3 > 90 Or Si3 <= 0 Then
    MsgBox Msg$
    SafetyFactor.Text = Format$(SF, " ")
    Exit Sub
End If
If Si4 > 90 Or Si4 <= 0 Then
    MsgBox Msg$
    SafetyFactor.Text = Format$(SF, " ")
    Exit Sub
End If
```

```
'trap friction angle input errors
Msg$ = "Check the friction angle input."
If Phi1 > 70 Or Phi1 < 0 Then
    MsgBox Msg$
    SafetyFactor.Text = Format$(SF, " ")
    Exit Sub
End If
If Phi2 > 70 Or Phi2 < 0 Then
    MsgBox Msg$
    SafetyFactor.Text = Format$(SF, " ")
    Exit Sub
End If
```

```
'trap discontinuity dip input errors
Msg$ = "Check the discontinuity dip direction input. "
If Alpha1 > 360# Or Alpha1 <= 0 Then
    MsgBox Msg$
    SafetyFactor.Text = Format$(SF, " ")
    Exit Sub
End If
If Alpha2 > 360# Or Alpha2 <= 0 Then
    MsgBox Msg$
    SafetyFactor.Text = Format$(SF, " ")
    Exit Sub
```

End If

Msg\$ = "Check the discontinuity dip magnitude input. "

If Si1 > 89.999 Or Si1 <= 0 Then

MsgBox Msg\$

SafetyFactor.Text = Format\$(SF, " ")

Exit Sub

End If

If Si2 > 89.999 Or Si2 <= 0 Then

MsgBox Msg\$

SafetyFactor.Text = Format\$(SF, " ")

Exit Sub

End If

'trap water pressure errors

Msg\$ = "Check the water pressure input."

If U1 < 0 Then

MsgBox Msg\$

SafetyFactor.Text = Format\$(SF, " ")

Exit Sub

End If

If U2 < 0 Then

MsgBox Msg\$

SafetyFactor.Text = Format\$(SF, " ")

Exit Sub

End If

'trap height errors

Msg\$ = "Check the height input."

If H < 0 Then

MsgBox Msg\$

SafetyFactor.Text = Format\$(SF, " ")

Exit Sub

End If

'trap rock density errors

Msg\$ = "Check the rock density input."

If gamma < 0 Then

```

    MsgBox Msg$
    SafetyFactor.Text = Format$(SF, " ")
    Exit Sub
End If

' Rem #1
    AX = Sin(Si1 * Pk) * Sin((Alpha1 - Alpha2) * Pk)
    AY = Sin(Si1 * Pk) * Cos((Alpha1 - Alpha2) * Pk)
    AZ = Cos(Si1 * Pk)
' Rem #2
    FX = Sin(Si4 * Pk) * Sin((Alpha4 - Alpha2) * Pk)
    FY = Sin(Si4 * Pk) * Cos((Alpha4 - Alpha2) * Pk)
    FZ = Cos(Si4 * Pk)
' Rem #3
    BY = Sin(Si2 * Pk)
' Rem #4
    BZ = Cos(Si2 * Pk)
' Rem #5
    I = AX * BY
' Rem #6
    GZ = FX * AY - FY * AX
' Rem #7
    Q = BY * (FZ * AX - FX * AZ) + BZ * GZ
' Rem #8
    If (N * Q / I) > 0 Or N * (FZ - Q / I) * Tan(Si3 * Pk) - Sqr(1 - FZ ^ 2) > 0 Then
        SafetyFactor.Text = Format$(SF, " ")
        Msg$ = "No wedge is formed. The analysis is complete"
        MsgBox Msg$
        Exit Sub
    Else
' Rem #9
        R = AY * BY + AZ * BZ
' Rem #10
        K = 1 - R ^ 2
' Rem #11
        L = (gamma * H * Q) / (3 * GZ)
' Rem #12
        P = -BY * FX / GZ
' Rem #13
        N1 = ((L / K) * (AZ - R * BZ) - P * U1) * P / Abs(P)
' Rem #14

```

```

    N2 = ((L / K) * (BZ - R * AZ) - U2)
' Rem #15
    M1 = (L * AZ - R * U2 - P * U1) * P / Abs(P)
' Rem #16
    M2 = (L * BZ - R * P * U1 - U2)

' Rem #17
    If N1 > 0 And N2 > 0 Then
        F = (N1 * Tan(Phi1 * Pk) + N2 * Tan(Phi2 * Pk) + Abs(P) * C1 + C2) * Sqr(K) /
Abs(L * I)
        ElseIf N2 < 0 And M1 > 0 Then
            F = (M1 * Tan(Phi1 * Pk) + Abs(P) * C1) / Sqr((L ^ 2 * (1 - AZ ^ 2) + K * U2 ^
2 + 2 * (R * AZ - BZ) * L * U2))
        ElseIf N1 < 0 And M2 > 0 Then
            F = (M2 * Tan(Phi2 * Pk) + C2) / (Sqr(L ^ 2 * BY ^ 2 + K * P ^ 2 * U1 ^ 2 + 2 *
(R * BZ - AZ) * P * L * U1))
        ElseIf M1 < 0 And M2 < 0 Then
            F = 0
        End If
    End If
    SafetyFactor.Text = Format$(F, "##0.00")
End Sub

```

```

Sub wedgeprint_Click ()
PrintForm
End Sub

```

```

Sub wedgexit_Click ()
    Form3.Hide
    Form1.Show
End Sub

```

```

Sub Command1_Click ()
    Form12.Show
    Form3.Hide
End Sub

```

### **Planreli2.frm**

```

Sub planecmd_Click ()

```

ReDim ArrayCohesion(1000), ArrayDiscon(1000), ArrayPhi(1000)

```
'Input from Form2
Face = Val(Faceangle.Text)
H = Val(Vertical.Text)
Crackdistance = Val(Distance.Text)
Gamma = Val(Density.Text)
Waterfilled = Val(Waterpercent.Text) / 100
SafetyFactorofInterest = Val(SFinterest.Text)
model = Val(Simsize.Text)
Densitywater = Val(Weightwater.Text)
```

```
simulation = 0
total = 0
SFCount = 0
```

```
PhiFile$ = Dir$(FrictionFile.Text)
Open PhiFile$ For Input As #1
  J = 0
  Do While Not EOF(1)
    Input #1, ArrayPhi(J)
    J = J + 1
  Loop
Close
```

```
GlueFile$ = Dir$(CohesionFile.Text)
Open GlueFile$ For Input As #1
  K = 0
  Do While Not EOF(1)
    Input #1, ArrayCohesion(K)
    K = K + 1
  Loop
Close
```

```
PlanFile$ = Dir$(DiscontinuityFile.Text)
Open PlanFile$ For Input As #1
  L = 0
  Do While Not EOF(1)
    Input #1, ArrayDiscon(L)
    L = L + 1
  Loop
Close
```

Results.Text = Space\$(3)'Clear the results box.

Do Until (simulation >= model)

PhiRandomValue = Int(Rnd \* J)

Phi = ArrayPhi(PhiRandomValue)

CohesionRandomValue = Int(Rnd \* K)

C = ArrayCohesion(CohesionRandomValue)

DisconRandomValue = Int(Rnd \* L)

Discon = ArrayDiscon(DisconRandomValue)

If Discon < Face Then

LLP = H / Sin(Discon \* Pk)

LLF = H / Sin(Face \* Pk)

THEDA = Face - Discon

DDA = Sqr(LLP ^ 2 + LLF ^ 2 - 2 \* LLP \* LLF \* Cos(THEDA \* Pk))

If Crackdistance > DDA Then Crackdistance = .9 \* DDA

DDZ = DDA - Crackdistance

Z = DDZ \* Tan(Discon \* Pk)

Zw = Waterfilled \* Z

W = .5 \* Gamma \* H ^ 2 \* (((1 - (Z / H) ^ 2) / Tan(Discon \* Pk)) - 1 / Tan(Face \* Pk))

a = (H - Z) / Sin(Discon \* Pk)

U = (.5 \* (Densitywater) \* Zw \* (H - Z)) \* (1 / Sin(Discon \* Pk))'Hydrologic uplift

V = .5 \* (Densitywater) \* Zw ^ 2 'Hydrologic push-out

ResistingF = (C \* a) + (W \* Cos(Discon \* Pk) - U - V \* Sin(Discon \* Pk)) \*

Tan(Phi \* Pk)

SlidingF = W \* Sin(Discon \* Pk) + V \* Cos(Discon \* Pk)

SF = ResistingF / SlidingF

total = total + 1

If SF > SafetyFactorofInterest Then SFCCount = SFCCount + 1

simulation = simulation + 1

Else sitnotformed = sitnotformed + 1

If (10 \* sitnotformed) = model Then

Msg\$ = "The simulation has produced a very large number of planes that do not daylight. Reliability has been calculated without attaining the simulation size requested. "

MsgBox Msg\$

Exit Do

End If

End If

```
Loop
If total > 0 Then
    Reliability = (SFCount / total) * 100
    Results.Text = Format$(Reliability, "##0.00")
Else
    Msg$ = "No valid data combinations were found"
    MsgBox Msg$
End If
End Sub
```

```
Sub planexit_Click ()
    Form4.Hide
    Form1.Show
End Sub
```

```
Sub planeprint_Click ()
    PrintForm
End Sub
```

```
Sub Command1_Click ()
    Form4.Hide
    Form20.Show
End Sub
```

### **Genhelp.frm**

```
Sub Command1_Click ()
    Form7.Hide
    Form1.Show
End Sub
```

### **Chelp22.frm**

```
Sub Command1_Click ()
    Form7.Hide
    Form1.Show
End Sub
```

### **Chelp24.frm**

```
Sub Command1_Click ()  
Form7.Hide  
Form1.Show  
End Sub
```

### **Cohehelp.frm**

```
Sub Command1_Click ()  
Form7.Hide  
Form1.Show  
End Sub
```

### **Cohehlp2.frm**

```
Sub Command1_Click ()  
Form7.Hide  
Form1.Show  
End Sub
```

### **Coplanhp.frm**

```
Sub Command1_Click ()  
    Form26.Show  
    Form27.Hide  
End Sub
```

```
Sub Command2_Click ()  
    Form31.Show  
    Form27.Hide  
End Sub
```

### **Cplanhlp.frm**

```
Sub Command1_Click ()  
    Form26.Show  
    Form27.Hide  
End Sub
```

```
Sub Command2_Click ()
```

```
Form31.Show  
Form27.Hide  
End Sub
```

### **Fahplan.frm**

```
Sub Command1_Click ()  
Form26.Show  
Form27.Hide  
End Sub
```

```
Sub Command2_Click ()  
Form31.Show  
Form27.Hide  
End Sub
```

### **Faplanhp.frm**

```
Sub Command1_Click ()  
Form26.Show  
Form27.Hide  
End Sub
```

```
Sub Command2_Click ()  
Form31.Show  
Form27.Hide  
End Sub
```

### **Fawedghp.frm**

```
Sub Command1_Click ()  
Form26.Show  
Form27.Hide  
End Sub
```

```
Sub Command2_Click ()  
Form31.Show  
Form27.Hide  
End Sub
```

### **Friwedhp.frm**

```
Sub Command1_Click ()  
    Form23.Show  
    Form32.Hide  
End Sub
```

### **Helpcoh.frm**

```
Sub Command1_Click ()  
    Form27.Show  
    Form31.Hide  
End Sub
```

### **Helpf.frm**

```
Sub Command1_Click ()  
    Form29.Show  
    Form30.Hide  
End Sub
```

### **Helpfang.frm**

```
Sub Command1_Click ()  
    Form16.Hide  
    Form11.Show  
End Sub
```

```
Sub Command2_Click ()  
Form28.Show  
Form16.Hide  
End Sub
```

### **Hlpfang2.frm**

```
Sub Command1_Click ()  
  
    Form18.Show
```

```
Form19.Hide
```

```
End Sub
```

```
Sub Command2_Click ()
```

```
Form6.Show  
Form19.Hide
```

```
End Sub
```

### **Morefa1.frm**

```
Sub Command1_Click ()
```

```
Form19.Show  
Form6.Hide
```

```
End Sub
```

```
Sub Command2_Click ()
```

```
Form23.Show  
Form6.Hide
```

```
End Sub
```

### **Planassu.frm**

```
Sub Command1_Click ()
```

```
Form8.Show  
Form10.Hide
```

```
End Sub
```

### **Plancond.frm**

```
Sub Command1_Click ()
```

```
Form9.Hide  
Form8.Show
```

```
End Sub
```

### **Planhelp.frm**

```
Sub Command1_Click ()  
Form9.Show  
Form8.Hide  
End Sub
```

```
Sub Command2_Click ()  
Form10.Show  
Form8.Hide  
End Sub
```

```
Sub Command3_Click ()  
Form2.Show  
Form8.Hide  
End Sub
```

```
Sub Command4_Click ()  
Form11.Show  
Form8.Hide  
End Sub
```

### **Planrkprp.frm**

```
Sub Command1_Click ()  
Form8.Show  
Form11.Hide  
End Sub
```

```
Sub Command2_Click ()  
Form15.Show  
Form11.Hide  
End Sub
```

```
Sub Command3_Click ()  
Form16.Show  
Form11.Hide  
End Sub
```

### **Rockpro2.frm**

```
Sub Command1_Click ()  
    Form12.Show  
    Form18.Hide  
End Sub
```

```
Sub Command2_Click ()  
    Form17.Show  
    Form11.Hide  
End Sub
```

```
Sub Command3_Click ()  
    Form19.Show  
    Form18.Hide  
End Sub
```

### **Rplanhlp.frm**

```
Sub Command1_Click ()  
    Form20.Hide  
    Form4.Show  
End Sub
```

### **Rweghlp.frm**

```
Sub Command1_Click ()  
    Form21.Hide  
    Form5.Show  
End Sub
```

### **Wedgech.frm**

```
Sub Command1_Click ()  
    Form24.Show  
    Form33.Hide  
End Sub
```

### **Wedgehlp.frm**

```
Sub Command1_Click ()
    Form13.Show
    Form12.Hide
End Sub
```

```
Sub Command2_Click ()
    Form14.Show
    Form12.Hide
End Sub
```

```
Sub Command3_Click ()
    Form12.Hide
    Form3.Show
End Sub
```

```
Sub Command4_Click ()
    Form18.Show
    Form12.Hide
End Sub
```

### **Wedhelp2.frm**

```
Sub Command1_Click ()
    Form13.Hide
    Form12.Show
End Sub
```

### **Wedhelp3.frm**

```
Sub Command1_Click ()
    Form14.Hide
    Form12.Show
End Sub
```

## VITA

John C. Bullock was born April 21, 1954 in Wilmington, North Carolina. He graduated with a Bachelor's Degree in Geology from North Carolina State University in 1976 and began his professional career in mining as a helper on a drill rig near Welch, West Virginia the following year. He subsequently worked twelve years as a geologist for Westmoreland Coal Company, resigning in 1990 to pursue a Mining Engineering Degree at Virginia Polytechnic Institute and State University.

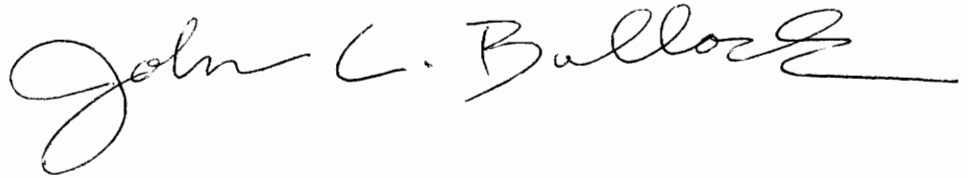
A handwritten signature in black ink that reads "John C. Bullock". The signature is written in a cursive style with a large, looping initial "J" and a long horizontal stroke at the end.