

THE DESIGN AND CONSTRUCTION OF A
SUNLIGHT INTEGRATOR OF WIDE INTENSITY RANGE

by

Edgar Wilson Glossbrenner

Thesis submitted to the Graduate Faculty of the
Virginia Polytechnic Institute
in candidacy for the degree of
MASTER OF SCIENCE
in
Physics

APPROVED:

Director of Graduate Studies

Dean of Academic Science and
Business Administration

APPROVED:

Head of Department

Supervisor or Major Professor

May, 1957

Blacksburg, Virginia

TABLE OF CONTENTS

	<u>Page</u>
LIST OF TABLES	3
LIST OF FIGURES	4
INTRODUCTION	5
REVIEW OF LITERATURE	7
DESIGN AND CONSTRUCTION OF THE INTEGRATOR	9
System Design	9
The Light Path	11
Filter Assembly	12
Detecting Device	15
Automatic Filter Selection	17
The Commutator	17
Measurement and Control	23
FUNCTIONING OF THE INTEGRATOR	25
Starting	25
Measuring Circuit	25
Filter Control Circuit	32
CALIBRATION AND TESTING OF THE INSTRUMENT	43
Reliability Tests	43
Filter Density Relations	49
SUMMARY	56
ACKNOWLEDGEMENTS	58
BIBLIOGRAPHY	59
VITA	61

LIST OF TABLES

<u>Tables</u>	<u>Page</u>
1. Effect of Exposure Conditions of Film on Light Transmission	13
2. Variation of Counting Period with Angle of Incidence	44
3. Variation of Counting Period with Line Voltage	47
4. Relative Filter Transmission	50
5. Calibration of Filters	54

LIST OF FIGURES

<u>Figures</u>	<u>Page</u>
1. Complete Assembly	6
2. Integrator System	10
3. Film Exposure Transmission Curves	14
4. Filter, Commutator, Motor Assembly	16
5. Commutator Design	18
6. Commutator	19
7. Brush Assembly	20
8. Filter-Commutator Segment Relations	22
9. Starting Circuit Connections	26
10. Operating Circuit Connections	27
11. Sensing Circuit	29
12. Counting Circuit	30
13. Grid Voltage Control Circuit	33
14. Plate Relay Circuit	34
15. Motor Control Circuit	36
16. Integrator Circuit	39
17. Integrator Wiring	41
18. Counting Rate vs. Angle of Incidence	45
19. Counting Period vs. Source Distance Squared	48
20. Effect of Filter Change on Counting Period vs. Source Distance Squared	51

INTRODUCTION

It has long been known that light is necessary for the proper development of living things. In recent years increasing attention has been directed toward the determination of the exact relationship of the phenomenon of growth to the quantity and quality of light radiation received by the various forms of plant and animal life.

In order to provide quantitative measurements of light energy, several integrating solar radiation recorders have been built. Nearly all of these have at least one of several limitations which has restricted its general acceptance. Some of these function with extreme simplicity but are not sensitive to the low light levels of early morning and late evening because the light intensity has been so greatly reduced to prevent overloading the sensitive surface. The pyrhellimeter which has the range and stability is prohibitively expensive for general use.

One design of integrator¹³ was constructed and tested and found to be insensitive to low light levels and completely inoperative at line voltages below 115 volts.

For these reasons the design of this integrator was undertaken to provide an instrument of moderate cost which would give reliable measurement of sunlight energy over a wide intensity range.

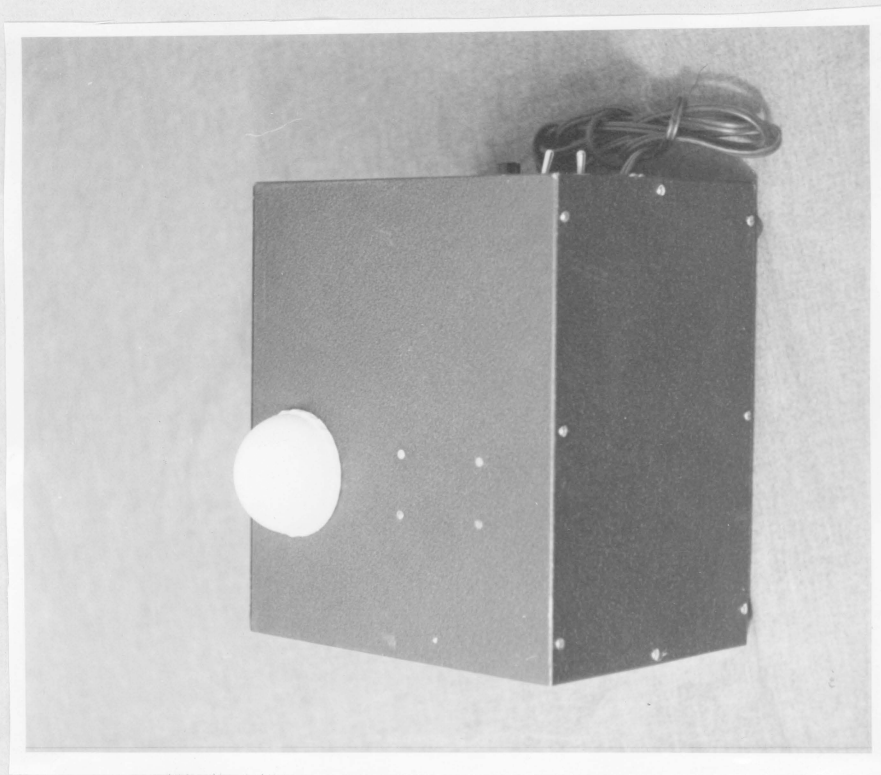

Fig. 1 Complete Assembly

REVIEW OF LITERATURE

Light intensity measurements have long been of interest to man. Although for many years photometry was dependent upon visual comparisons, developments of the last fifty years have produced much more reliable measurements. Only recently has attention been turned on the measurement of quantity of light or exposure.

Among the earliest methods of measurement of light exposure was that of Rentschler¹⁴ who in 1930 reported the use of photoelectric current to charge a condenser. The voltage developed across this condenser was used as the starter voltage of a gas trigger triode tube. This circuit was used to supply a counter upon which the total number of charging cycles for the condenser was recorded. This development has been used as the basic concept of many types of light integrating devices for many purposes.

Wallace¹⁸ has shown that the use of an opal glass spherical dome over the photosensitive surface improves the directional characteristics, providing more uniform sensitivity regardless of the position of the source. From this Giovanelli⁶ has developed a photometer using plastic domes to advantage.

Several simple phototube type integrators have been built by Sprague and Williams^{16,17} utilizing this information. Further refinement of this type of instrument

has been done by Somers and Hamner¹⁵ who have constructed a phototube circuit which utilizes a motor driven rotary switch to choose a separate counter for each day's record of light exposure.

Babcock² has used a photomultiplier tube as the sensing element to supply a circuit of the Rentschler type. Hariharan and Bhalla⁷ have controlled the supply voltage of the photomultiplier tube to provide constant current regardless of light intensity. The variations in the supply voltage provide the motivation for the recording circuit.

DESIGN AND CONSTRUCTION OF THE INTEGRATOR

System Design

The block diagram of the system is shown in Fig. 2. Sunlight falling on the instrument from any direction is diffused by a white translucent dome before passing through a shutter into a light-tight inner compartment. This diffused light is then allowed to pass through one of a series of filters. This filter reduces the intensity of the light to the proper level for application to the sensing element.

The detector for the integrator is a photomultiplier tube which supplies current to the measuring circuit in proportion to the intensity of the sunlight. The current is divided into discreet pulses which when amplified will be recorded on one of a series of counters selected by a motor driven commutator. The measuring circuit also supplies the signal to the vacuum tube control circuit for the motor operation. The motor not only drives the commutator but also simultaneously positions the proper reducing filter in the light path.

For convenience the entire integrator is designed to operate from standard ac supply circuits. The supply for the photomultiplier tube is regulated to insure reliable operation under normal variations of line voltage. A simple method⁹ of stabilizing this ac voltage has been

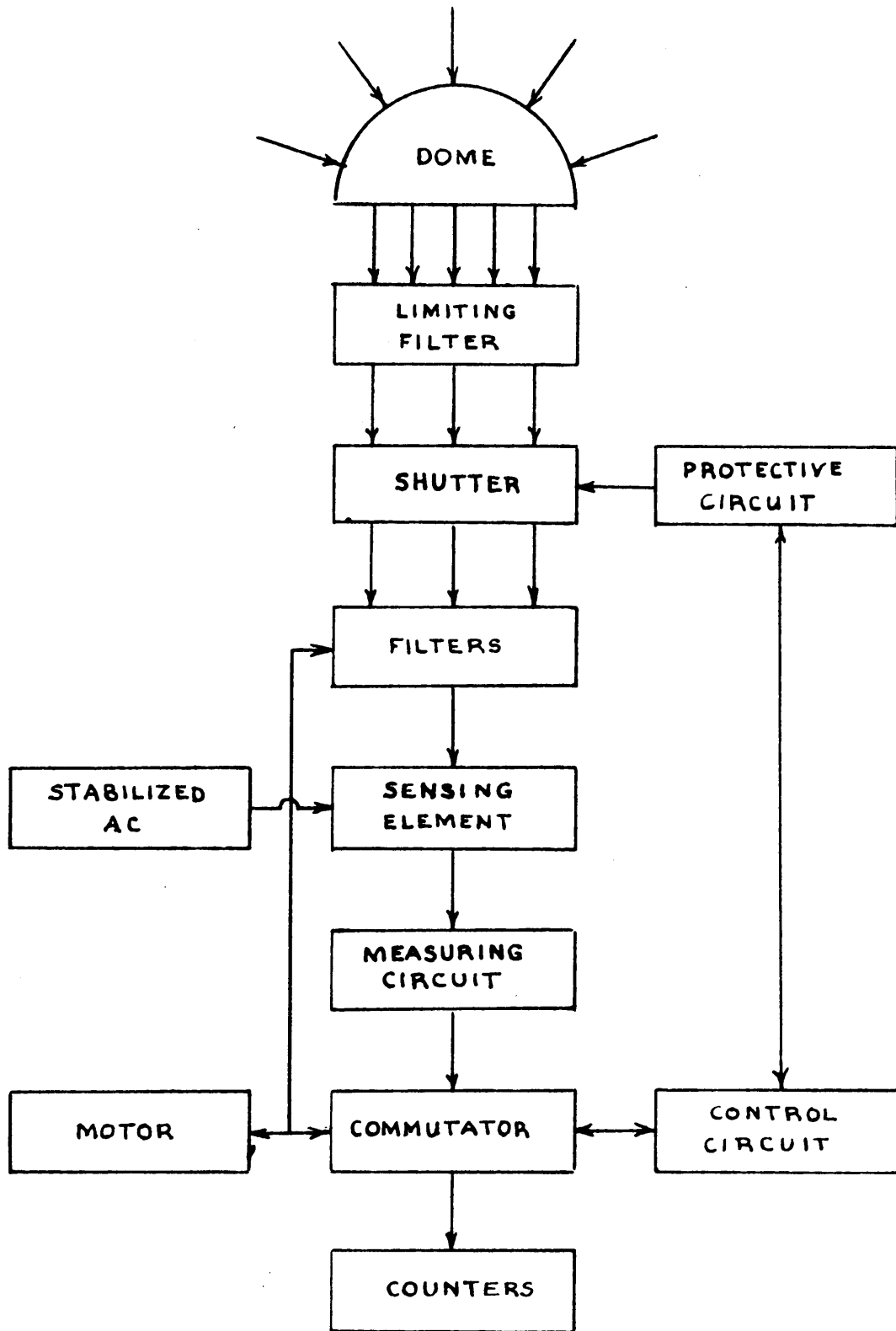

FIG. 2 INTEGRATOR SYSTEM

supplied as has a circuit to close the shutter and protect the instrument in the event of overload or power failure.

The Light Path

Sunlight enters the instrument through a translucent white plastic dome. This dome is hemispherical in shape to collect light from all directions. The plastic dome possesses excellent diffusing properties and some light absorption. For a field unit, it has the added advantage of ruggedness. The hemispherical shape was selected because of its availability and the practical independence of light transmission and angle of incidence. The light transmitted by the dome is again diffused by a ground glass disc and passed through an intensity limiting filter to reduce the incident light to the maximum measurable by the instrument.

Next, the light enters a light-tight inner chamber by passing through an aperture protected by a sliding shutter. The shutter is provided to close the light path at all times when the instrument is inoperative. This prevents the intense noon sunlight from accidentally striking the unprotected cathode surface of the photomultiplier tube. The shutter is held open by a solenoid while the instrument is functioning, allowing light to enter the inner light-tight compartment. If the power is cut off, the spring

loaded shutter immediately closes the aperture.

Filter Assembly

In order to provide an ample intensity range, the light is further passed through one of a series of six filters. The filters are photographic films which have been exposed to a uniform light intensity. Films were chosen for use as filters because they are inexpensive, easily reproducible, and have generally uniform spectral transmission in the visible and near ultraviolet regions of the spectrum.

The films were prepared by removing the lens of a camera having a focal plane shutter. The one used was a Contax D type. The camera was placed on the table of a photographic enlarger which has an indirect fluorescent light source such as the Kodak Hobbyist. This provided a uniform light intensity over the entire frame. The exposure was controlled by the iris diaphragm (f-number) on the enlarger, the time of exposure, and the lamp-to-film distance. The films were developed with fresh chemicals according to the techniques recommended by the film manufacturer. In this way the density of the developed film and therefore the percent transmission may be selected. Table 1 and Fig. 3 show the relationship between f-number, time, and the percent transmission of the resultant films. The lamp-to-film distance was arbitrarily held constant.

Table 1
 Effect of Exposure Conditions of Film
 on Light Transmission

<u>F-number</u>	<u>Film</u>	<u>Time (Sec.)</u>	<u>Trans. (%)</u>	
6.3	22	1	.5	.6
	23	1/2	.7	.7
	24	1/5	.8	.8
	25	1/10	1.0	1.0
	26	1/20	1.9	2.0
8	27	1	.65	.7
	28	1/2	.8	.9
	29	1/5	.9	1.4
	30	1/10	1.1	1.7
	31	1/20	2.2	2.8
11	32	1	.9	.9
	33	1/2	1.2	1.3
	34	1/5	2.1	2.0
	35	1/10	2.3	2.8
	36	1/20	4.3	4.6
16	37	1	1.3	1.3
	38	1/2	1.8	1.9
	39	1/5	3.1	3.1
	40	1/10	4.6	4.6
	41	1/20	7.8	7.8
22	42	1	1.9	2.0
	43	1/2	2.8	-
	44	1/5	5.1	5.1
	45	1/10	7.6	7.7
	46	1/20	13.0	-

FIG. 3 FILM EXPOSURE TRANSMISSION CURVES

GAS FILLED TUNGSTEN SOURCE

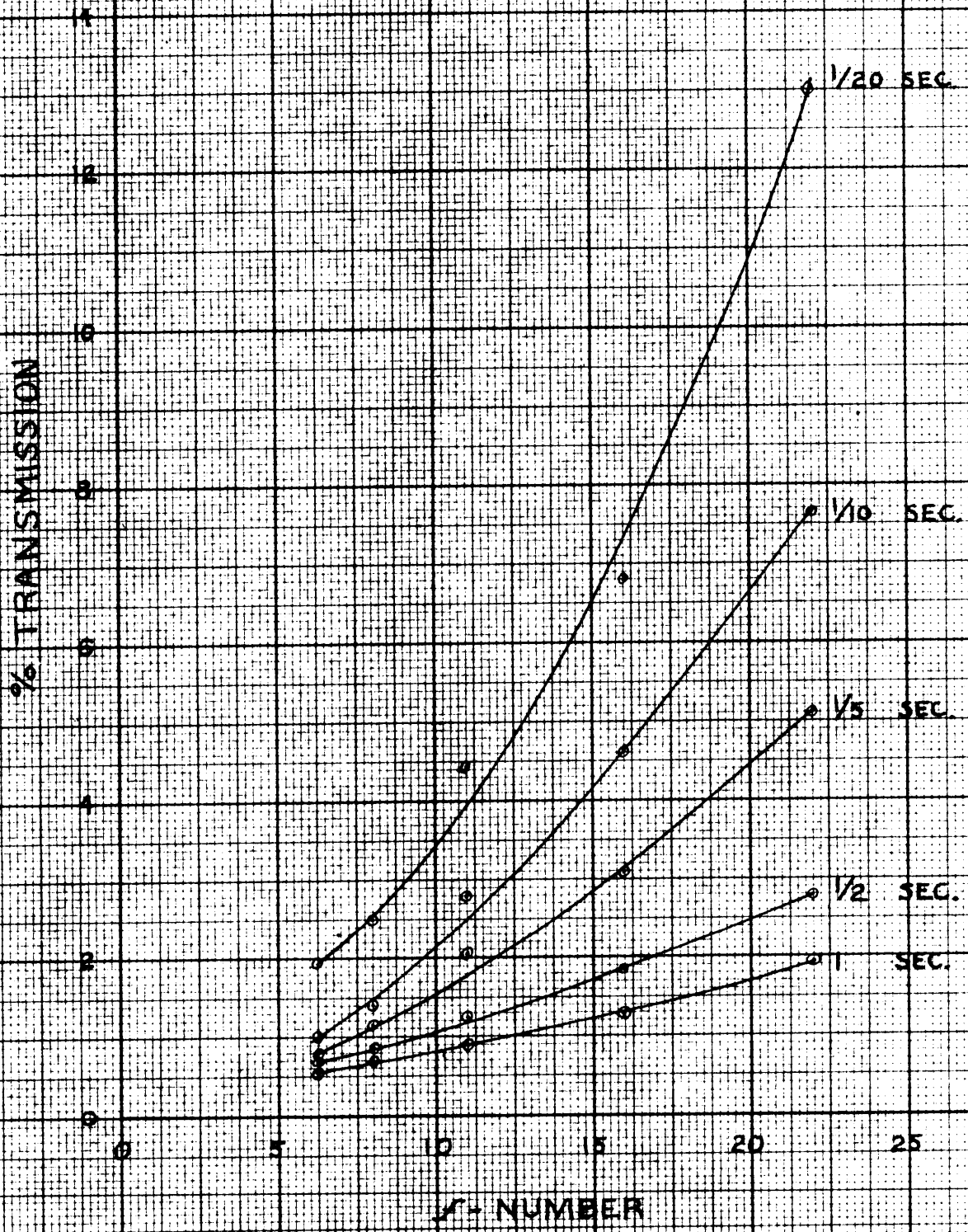

EUGENE DIETZGEN CO.
MADE IN U. S. A.

NO. 340 .20 DIETZGEN GRAPH PAPER
20 X 20 PER INCH

The percent transmission was measured with a Bausch and Lomb visual photometer using white gas filled tungsten light. The films were combined into six filters, each filter having a measured transmission of about 5% of the preceding one. The actual transmission of the filters is about 12% as measured by the integrator. This gives an over-all intensity reduction factor for the filters alone of about $\frac{1}{2} \times 10^{-5}$.

The filters are mounted end to end in order of increasing density around a transparent plastic cylinder formed by heating a lucite sheet over a low flame and bending it around a wooden dowel approximately $2\frac{1}{2}$ inches in diameter. In this manner each filter covers one-sixth of the total circumference of the cylinder.

This filter system is rigidly attached to the shaft of a motor and commutator assembly so that the cylinder may be rotated by the motor into any filter position selected by the commutator. The filter cylinder is fitted into a stationary metal sleeve to prevent stray light from striking the sensing element located inside the rotating filter cylinder. This is shown in Fig. 4.

Detecting Device

The sensing element or detecting device is a type 931-A photomultiplier tube. The sensitivity of this tube is so great that it is necessary to wrap the tube with

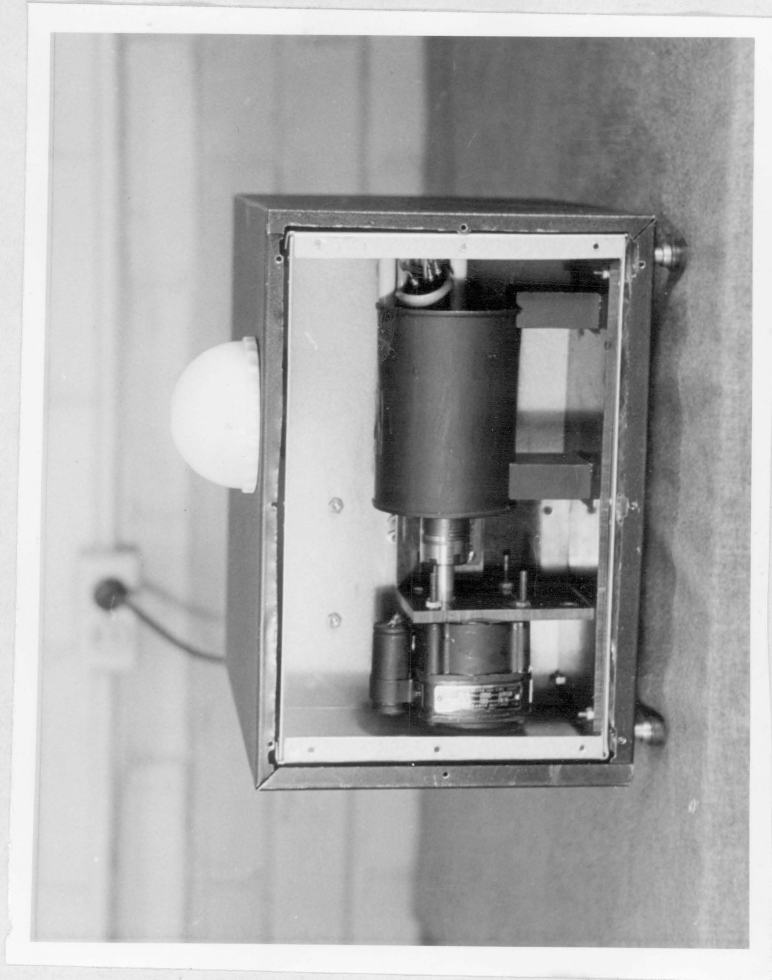

Fig. 4 Filter, Commutator, Motor Assembly

tape except in the cathode area to prevent stray light from reducing the accuracy of the readings.

Automatic Filter Selection

The filters are rotated about the detector tube by a switching motor geared to drive the filters at about one revolution per minute until positioned in the light path. This positioning must be accurate to permit the light to impinge on only one filter at a time. The stopping of the filter in the proper location is controlled by a special commutator and brush assembly designed and constructed by the writer.

The Commutator

The commutator consists of ten sections of interconnected platinum-silver segments shown in Fig. 5. Contact to each section is made by a group of three palladium-gold brushes. See Fig. 7. These materials, kindly furnished by the Poly-Scientific Corporation, were selected for long life and to minimize tarnish under ordinary service conditions.

Section H consists of a continuous ring and provides continuous electrical contact to all segments of the commutator. Six of these sections, A through F, have one conductive segment per section. Each of these segments is fifty degrees in arc length and is positioned so that the center of the segment is sixty degrees clockwise from the

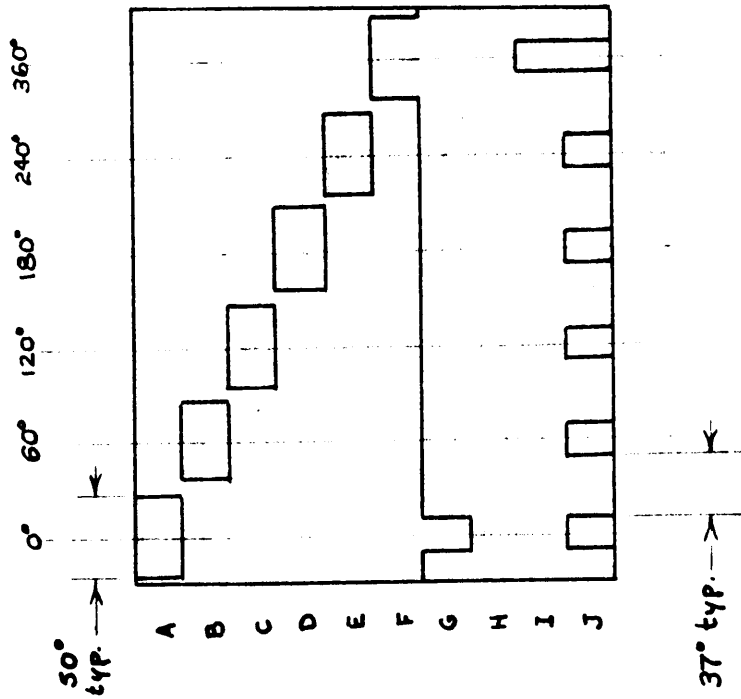
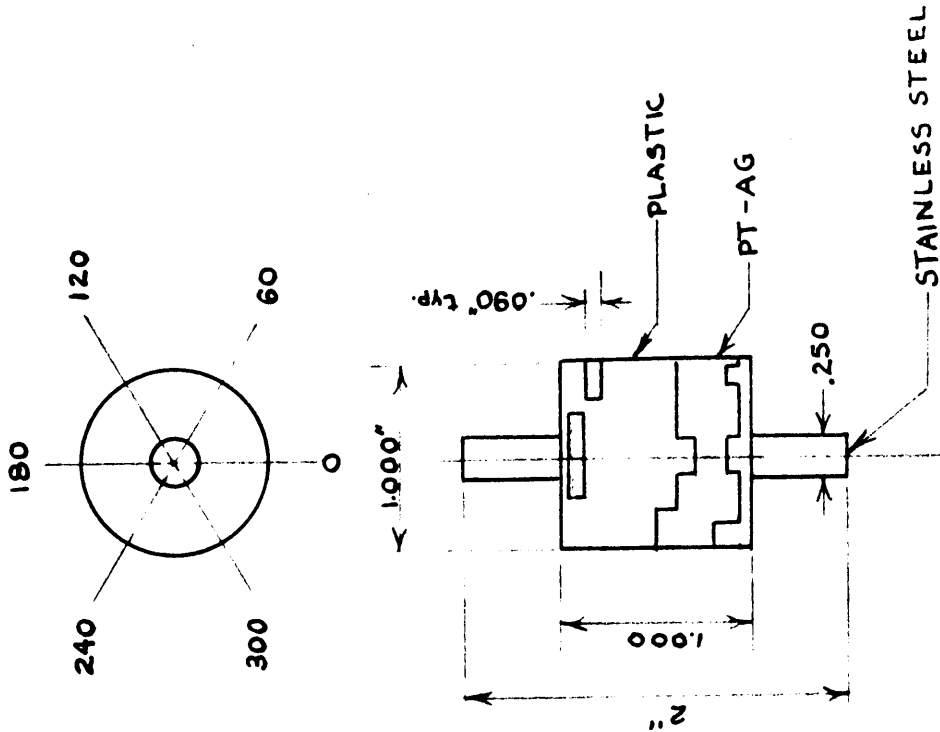

DEVELOPED PLAN
OF SEGMENTS
(NO SCALE)

(SCALE 1:1)

FIG. 5 COMMUTATOR DESIGN



Fig. 6 Commutator

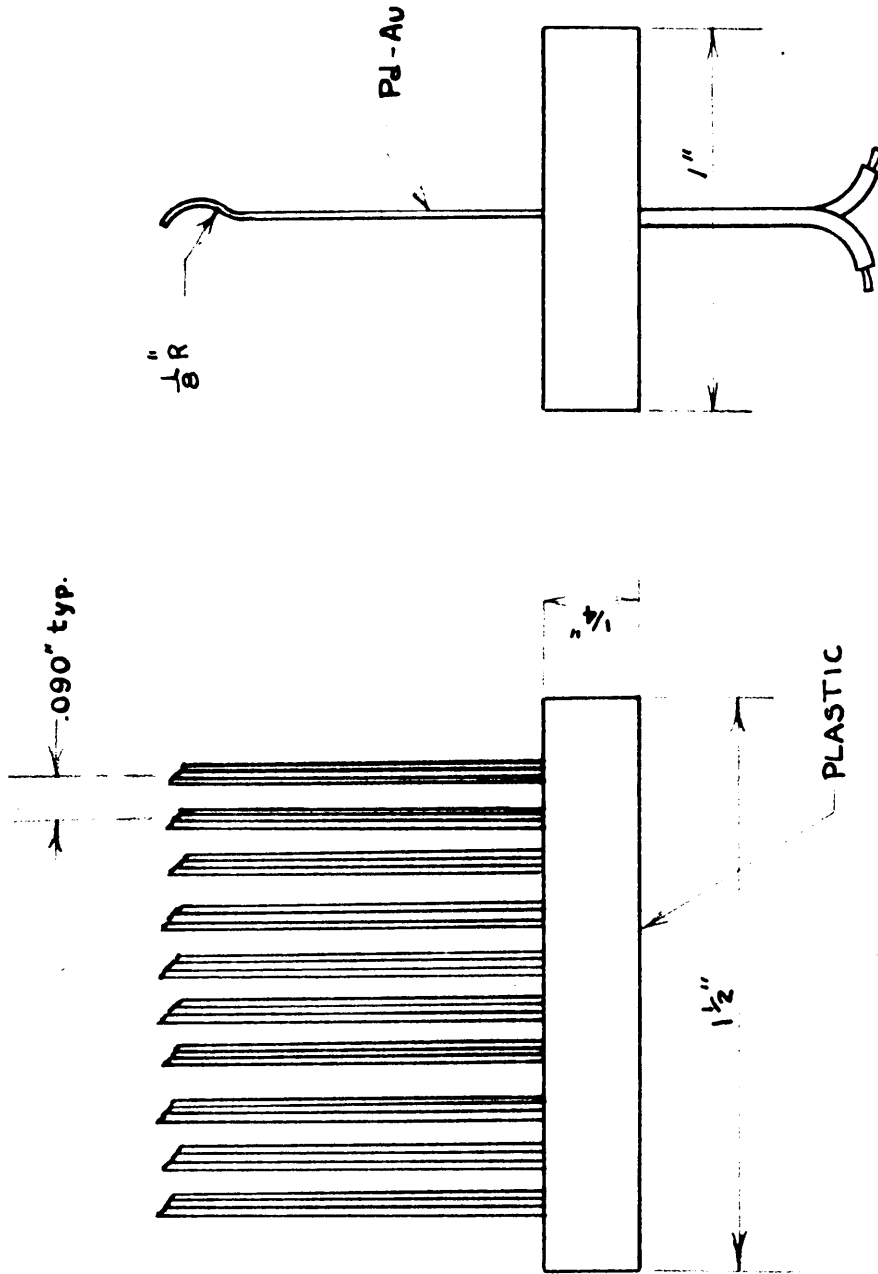

FIG 7 BRUSH ASSEMBLY

preceding one. Each segment is also oriented with a filter, 1 through 6, and when that filter is in use, contact is made to the segment by a brush connected to the proper pulse counter. It is in this way that each filter has a specific counter which records pulses developed by light passing through that filter. These six sections provide a switching means for the six counters. The complete plan of the commutator segments and their relationship to the filters is shown in Fig. 8.

Three additional sections control the operation of the switching motor. Two of these have 347 degrees of conductive segment. Segment I is located so that the center of the non-conductive area is alligned with the center of the segment in section F. This section prevents the commutator from overshooting the most dense filter and exposing the sensitive surface to an intense light. Segment G is similarly positioned with respect to segment A to prevent the motor from continuously rotating at extremely low light levels. Section J has six 37 degree conducting segments located at 60 degree intervals in such a manner that the center of the non-conducting interval corresponds to the center of each counter segment, A through F, and hence to the center of each filter. This section in conjunction with the control circuit stops the motor so that each filter is exactly centered in the light path.

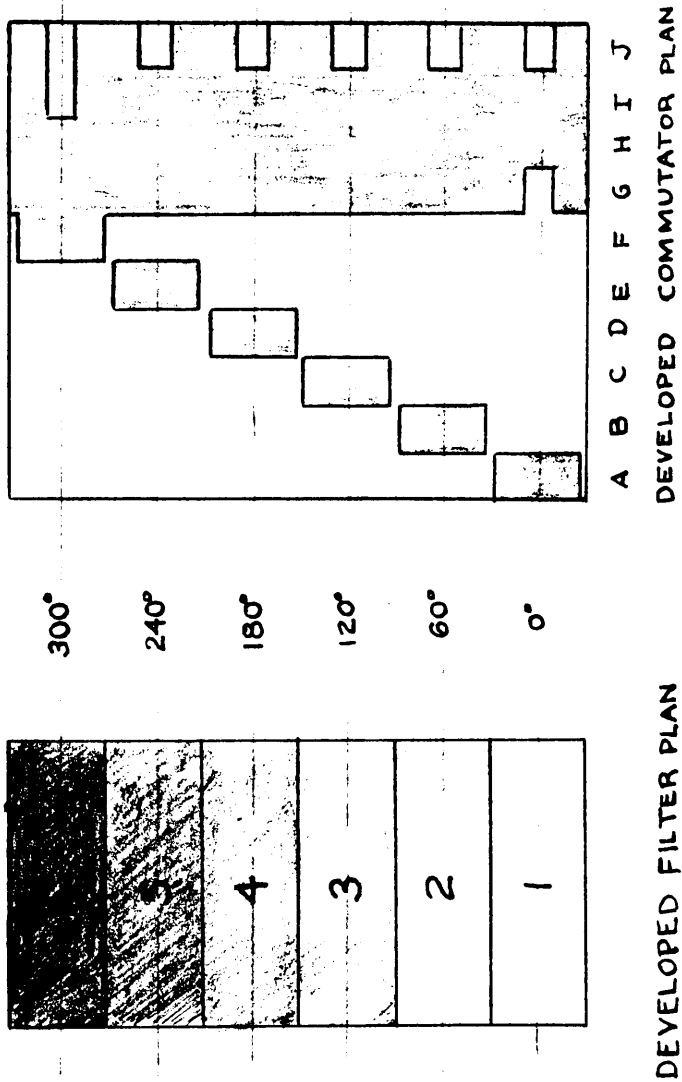

FIG. 8
FILTER COMMUTATOR SEGMENT RELATIONS

Measurement and Control

All photomultiplier tubes may be operated on ac voltage, but they are extremely voltage sensitive, a voltage variation of ten percent causing nearly one hundred percent change of output current. Variations of line voltage are minimized by use of two voltage reference tubes in the ac supply to the multiplier phototube. The output current is a measure of the sunlight intensity striking the photomultiplier tube.

The output of the tube is divided into pulses, each pulse representing a specific amount of solar energy. These pulses are then recorded on counters after the method of Rentschler¹⁴. The appropriate counter is determined by the control circuit and selected by the commutator in conjunction with the filter in the light path.

The control circuit operation is dependent upon the counting rate developed by the sensing element. If the counting rate becomes too high, the control circuit automatically places a more dense filter in the light path and switches to the corresponding counter. Similarly this circuit will position a less dense filter in the light path if the counting rate becomes too low. Each time a filter change occurs, a simultaneous counter change also occurs so that light passing through any specific filter is always recorded on the same counter. This allows the

integrator to function unattended other than to be read
at convenient intervals.

FUNCTIONING OF THE INTEGRATOR

Starting

To operate the integrator, switches 1 and 2 are thrown to the "start" position. This energizes the filament of the 25L6-GT tube. At the same time contact is made through segment I to the clockwise terminal of the motor causing it to rotate the most dense filter into the light path. Rotation continues until brush I contacts the dead segment of Section I. This circuit is shown in Fig. 9.

When the motor ceases to run, switch 1 is placed in the "power" position. This applies current to the entire instrument except the protective circuit which is activated as switch 2 is moved into the "operate" position as shown in Fig. 10. This last action also allows the control circuit to select the proper filter for the incident light intensity at that time. The simultaneous activation of the protective circuit opens the shutter allowing the instrument to function and energizes the contacts of the overload relay, Rel 5, for protection of the multiplier tube should the photocurrent become excessive.

Measuring Circuit

The unregulated ac voltage from the supply is applied through R_{16} to two OC3 tubes in parallel back to back to limit the peak voltage applied to the transformer thus

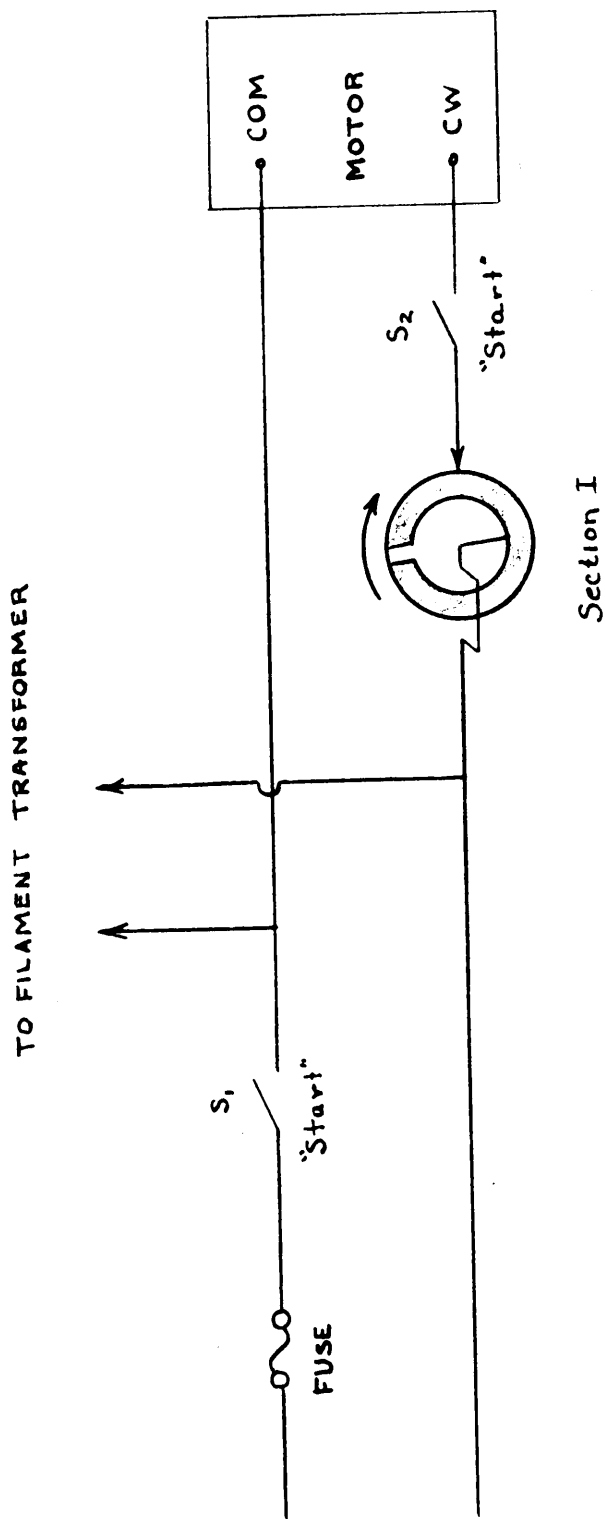

FIG. 9
STARTING CIRCUIT CONNECTIONS

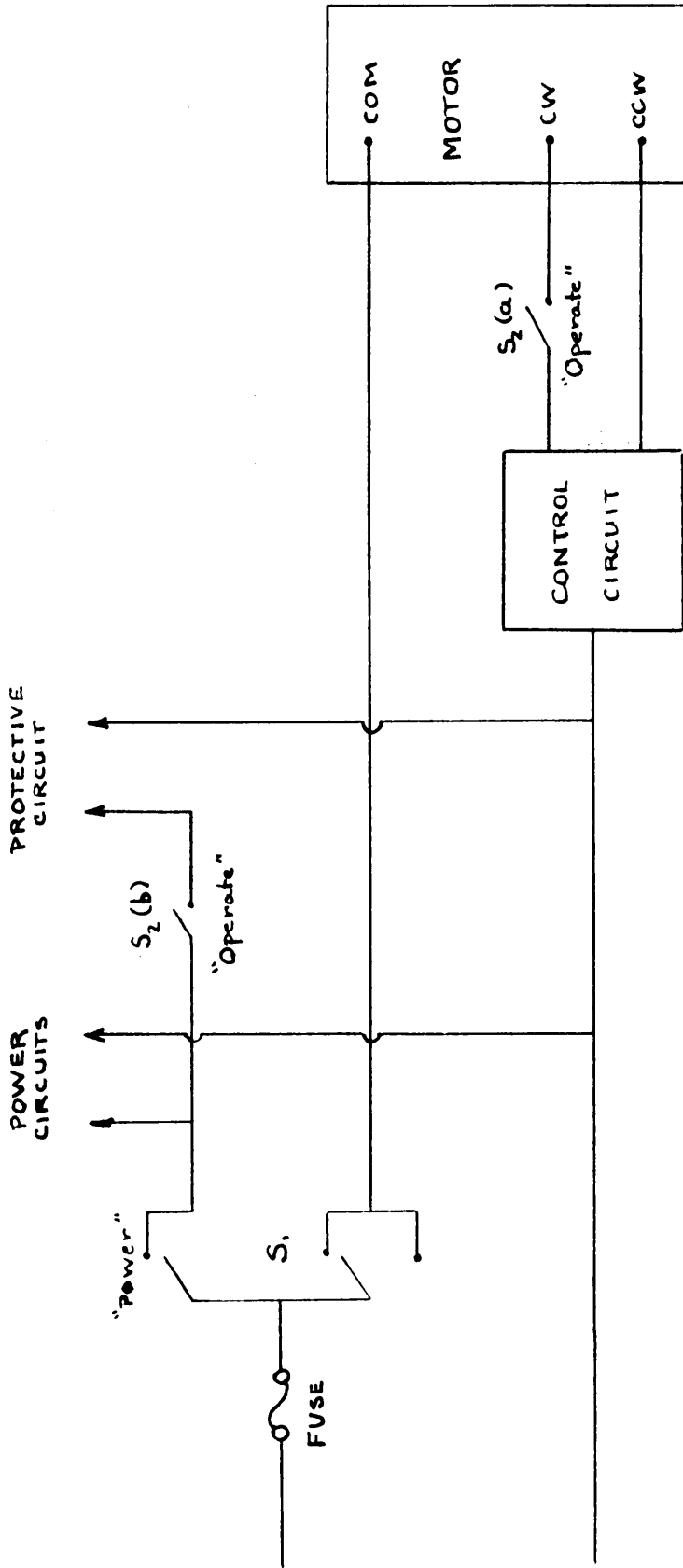

FIG. 10
OPERATING CIRCUIT CONNECTIONS

giving an essentially uniform ac supply to the multiplier phototube voltage divider, R_1 through R_{10} . See Fig. 11. This supplies an ac voltage to each dynode of the tube which is self-rectifying and permits a pulsating photocurrent to be multiplied in the tube. Although the current is half wave, the average is still proportional to the light striking the photo-cathode, and therefore the anode current per cycle represents the average light intensity over that cycle.

This anode current is applied to condenser C_1 , shown in Fig. 12, charging it toward the peak instantaneous potential across the last stage of the divider circuit, R_{10} . At the same time a small ac voltage is developed across C_1 by ac leakage through condenser C_2 and its limiting resistor, R_{11} , superimposing on the dc voltage. When the sum of the dc potential and the instantaneous ac reaches the starting potential of the OA4-G tube, breakdown occurs between the starter anode and the cathode. Since the small ac voltage is in phase with the anode voltage of the OA4-G tube, the peak voltage across C_1 occurs on the positive half cycle of anode supply voltage. This acts as a synchronizing voltage to insure that the discharge will always transfer to the anode-cathode path in the tube. Without this synchronizing, ionization could occur between starter anode and cathode without trans-

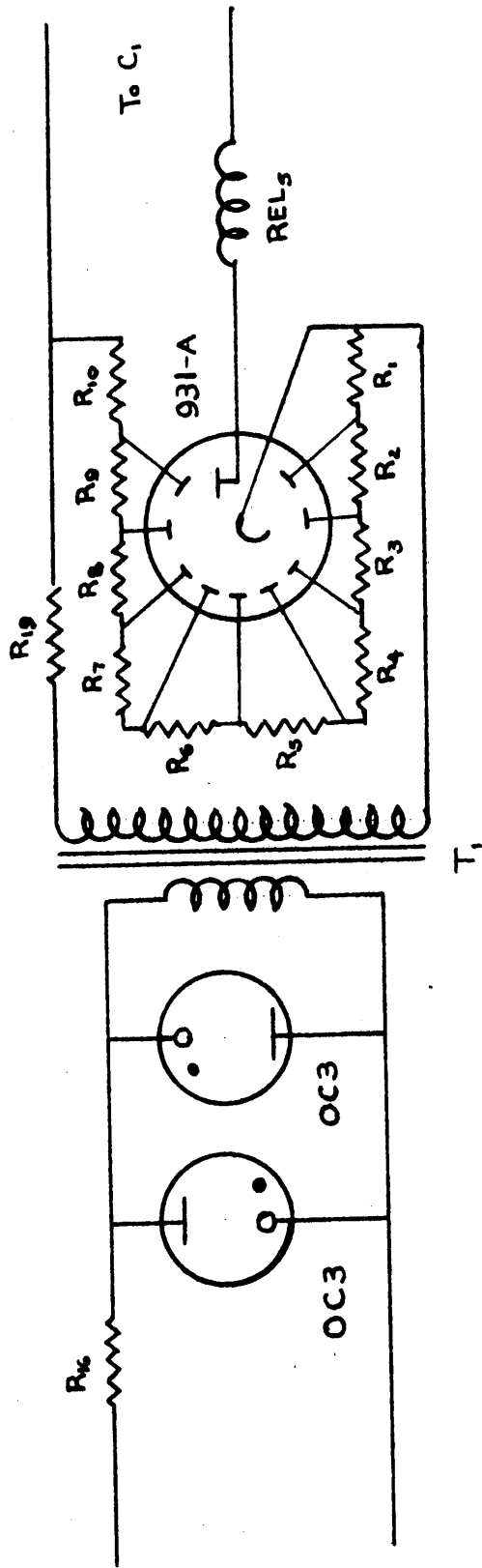

FIG 11
SENSING CIRCUIT

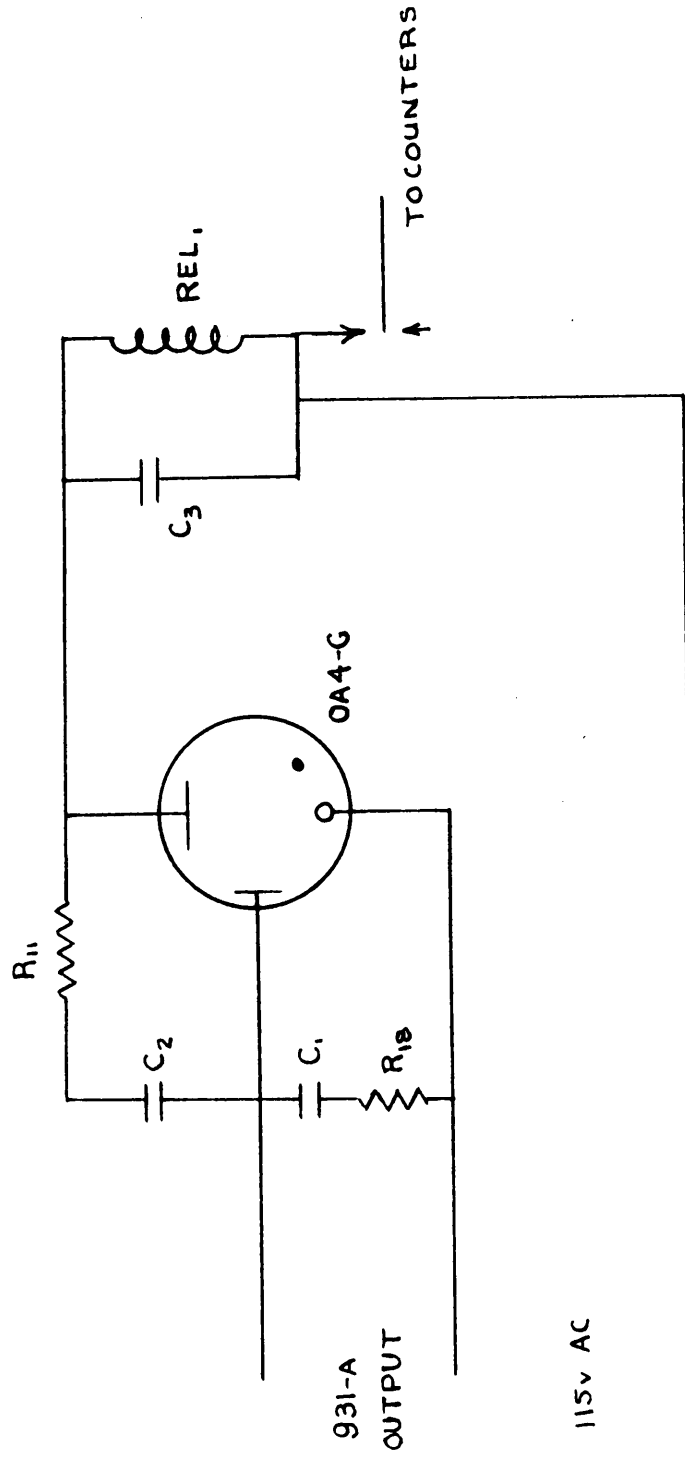

FIG. 12 COUNTING CIRCUIT

ferring to the anode-cathode path. The pulse of current would not be counted and errors of measurement would result.

When the starter anode causes breakdown in the OA4-G relay tube, the condenser C_1 is discharged to a voltage equal to the tube drop of the gas filled OA4-G tube. Condenser C_1 is now free to begin recharging. Since the breakdown voltage of the tube is constant for a given anode voltage and the tube drop is constant for the tube, the quantity of charge involved in each cycle of condenser buildup is therefore a constant. This charge represents a definite quantity of light energy.

When the discharge occurs from the starter anode to the cathode, a pulse of current is permitted through the anode circuit of the ionized tube momentarily actuating relay 1. The condenser C_3 across the coil simply insures a sufficient period of pulse width to allow complete closing of the relay. One set of contacts of relay 1 supplies a pulse to operate the pre-selected counter thus recording the unit of light energy.

The total of these units is the time integral of light intensity recorded by the instrument and therefore represents light energy. The exact value of the units is determined by calibration.

Filter Control Circuit

The counting rate of the instrument is used as reference for selection of the proper filter. A second set of contacts on relay 1 momentarily closes an 18 volt dc circuit charging capacitor C_4 . See Fig. 13. This condenser has a capacity of 4000 microfarads shunted by a 3000 ohm resistor, R_{12} . For this reason the charge is constantly draining from the condenser. The average voltage across the capacitor, C_4 , is determined by the counting rate of relay 1.

This average voltage is applied to the control grid of the 25L6-GT vacuum tube through resistor, R_{13} . Since this is a negative grid voltage, the greater the counting rate the less current permitted through the vacuum tube.

The plate circuit of the 25L6-GT tube contains two relays in parallel arrangement, one of which has a series resistor, R_{15} , making it less sensitive to the total plate current output of the tube. See Fig. 14. The contacts of these relays are so connected that relay 2 contacts close when the relay is de-energized, that is, at extremely low plate current. Relay 3 contacts close when it is energized at very high plate current. The contacts of these plate circuit relays are used to initiate the motor action for changing filters in the light path.

If the filter in the path transmits too much light,

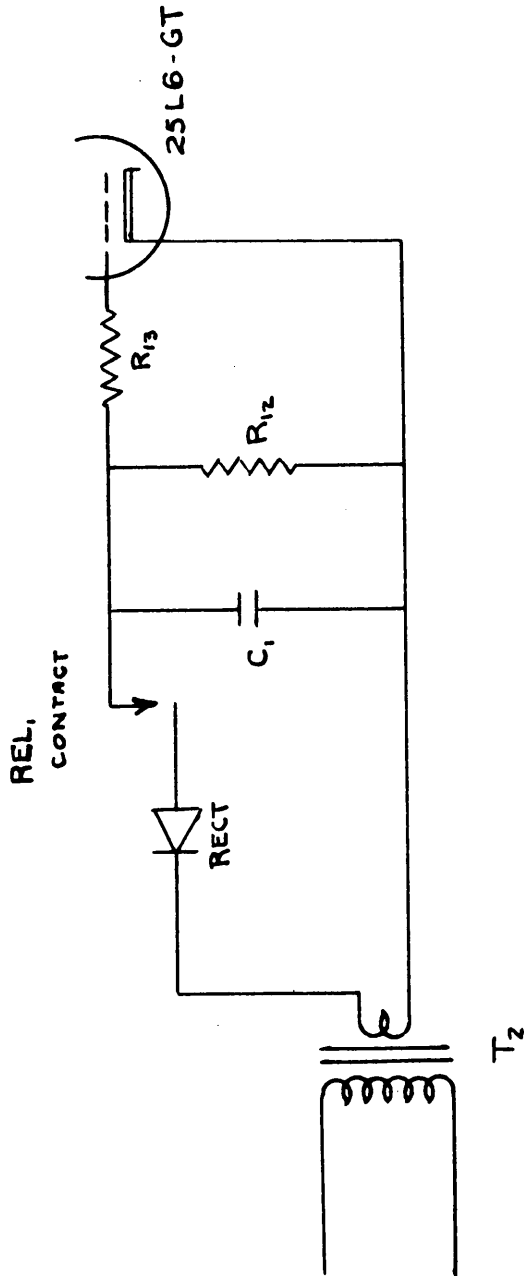

FIG. 13

GRID VOLTAGE CONTROL CIRCUIT

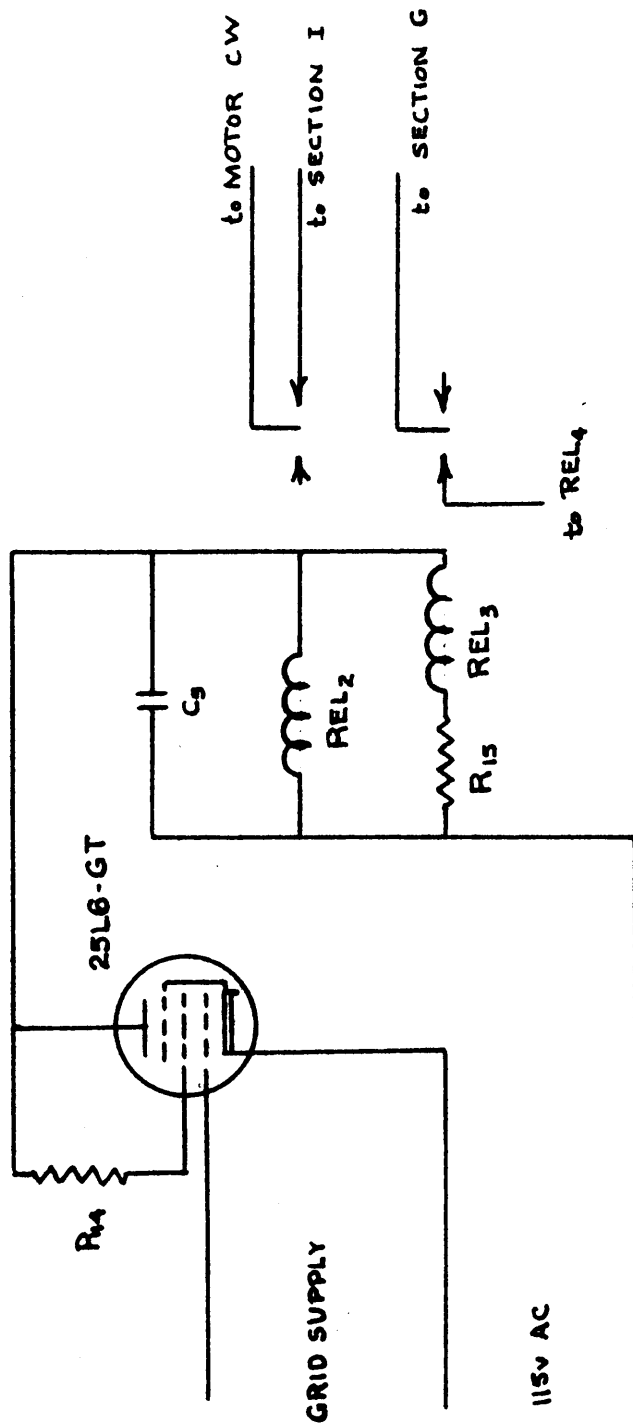

FIG 14
 PLATE RELAY CIRCUIT

the counting rate rises causing control tube grid voltage to become more negative reducing the plate current through the relays. When this current becomes too small to maintain relay 2 in the energized position, the relay contacts close and the motor begins to rotate a more dense filter into the light path. As this more dense filter enters the light path, the counting rate decreases and relay 2 is again energized. Simultaneously with the change of filters, a change of counter segments occurs and hence a change of counters. By this time one segment of section J on the commutator has made contact with its brush. Even though relay 2 contacts have opened, the rotation of the filter-commutator assembly is sustained by segment J until the brush breaks contact with the segment. The rotation then stops and the filter is positioned properly in the light path. This portion of the circuit is shown in Fig. 15.

If the light intensity should increase again, the process will again be repeated until the most dense filter covers the photomultiplier tube. When the maximum filter is in the light path, brush I is located on a dead segment and the motor cannot run even though the contacts of relay 2 may be closed. The maximum filter has been found to have ample density for noontime sunlight in the Blacksburg, Virginia, area.

As the light intensity declines, the counting rate

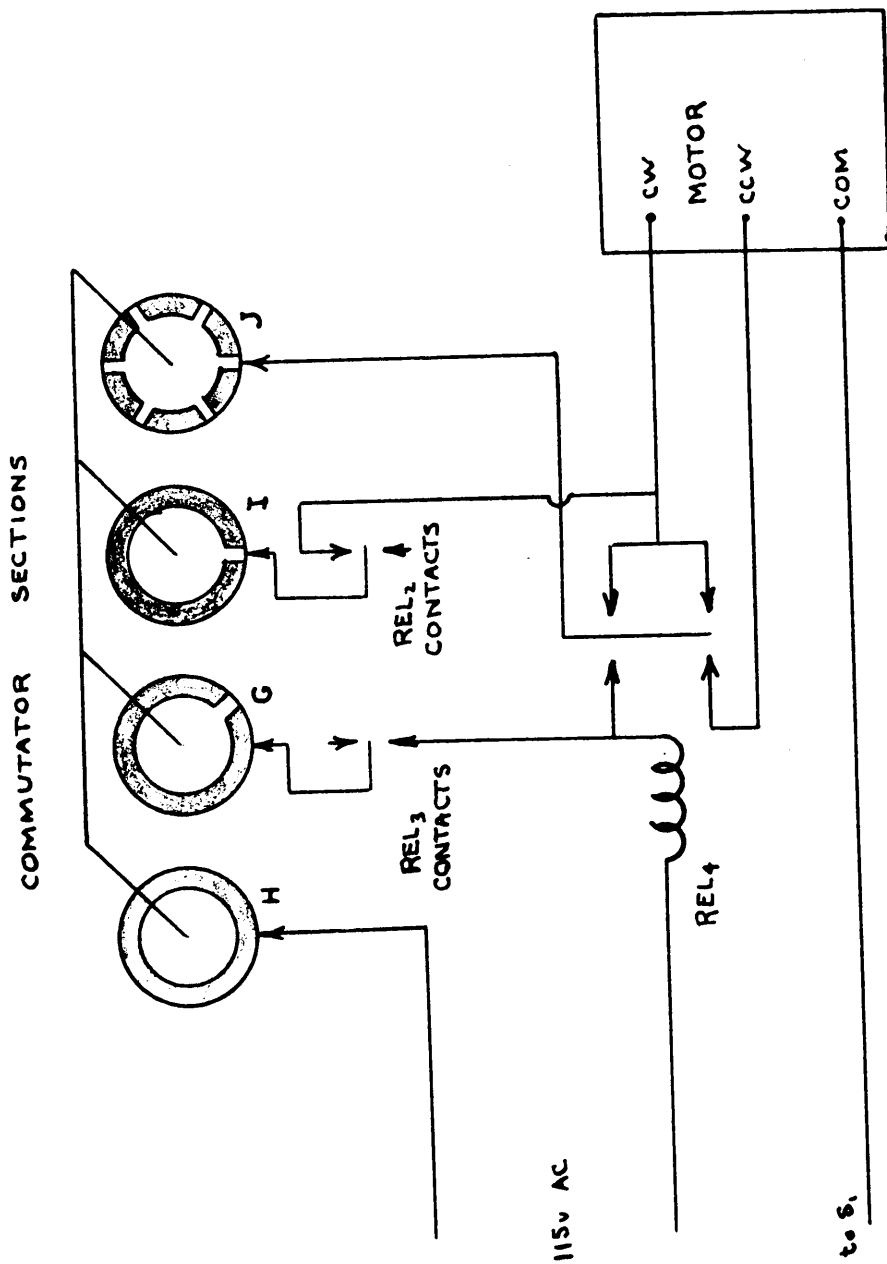

FIG. 15

MOTOR CONTROL CIRCUIT

decreases and the control grid voltage becomes more positive allowing more current to flow through the plate circuit. When the current becomes sufficient, relay 3 will energize. The closing of the contacts of relay 3 energizes relay 4. This is a double pole double throw relay. One set of contacts opens the circuit from segment J to the clockwise terminal of the motor and closes the circuit from segment J to the counter-clockwise terminal. At the same time contact is made through the contacts of relay 3 to initiate the counter-clockwise rotation of the motor. When the rotation has progressed through about fifteen degrees, segment J contacts its brush and relay 4 is held energized. The motor moves the less dense filter into the field reducing the plate current and de-energizing relay 3. Simultaneously it switches in the appropriate counter. The rotation stops in the correct position when the brush disengages segment J. Relay 4 de-energizes and the process is complete.

This action is repeated as the light intensity decreases until the least dense filter is in the light path. Further rotation in the counter-clockwise direction is prevented by the dead segment of section G which maintains an open circuit to relay 3.

In this manner the instrument selects the proper filter for use in measuring the light intensity in which it

is operating. The complete circuit diagram is shown in Fig. 16 and pictured in Fig. 17.

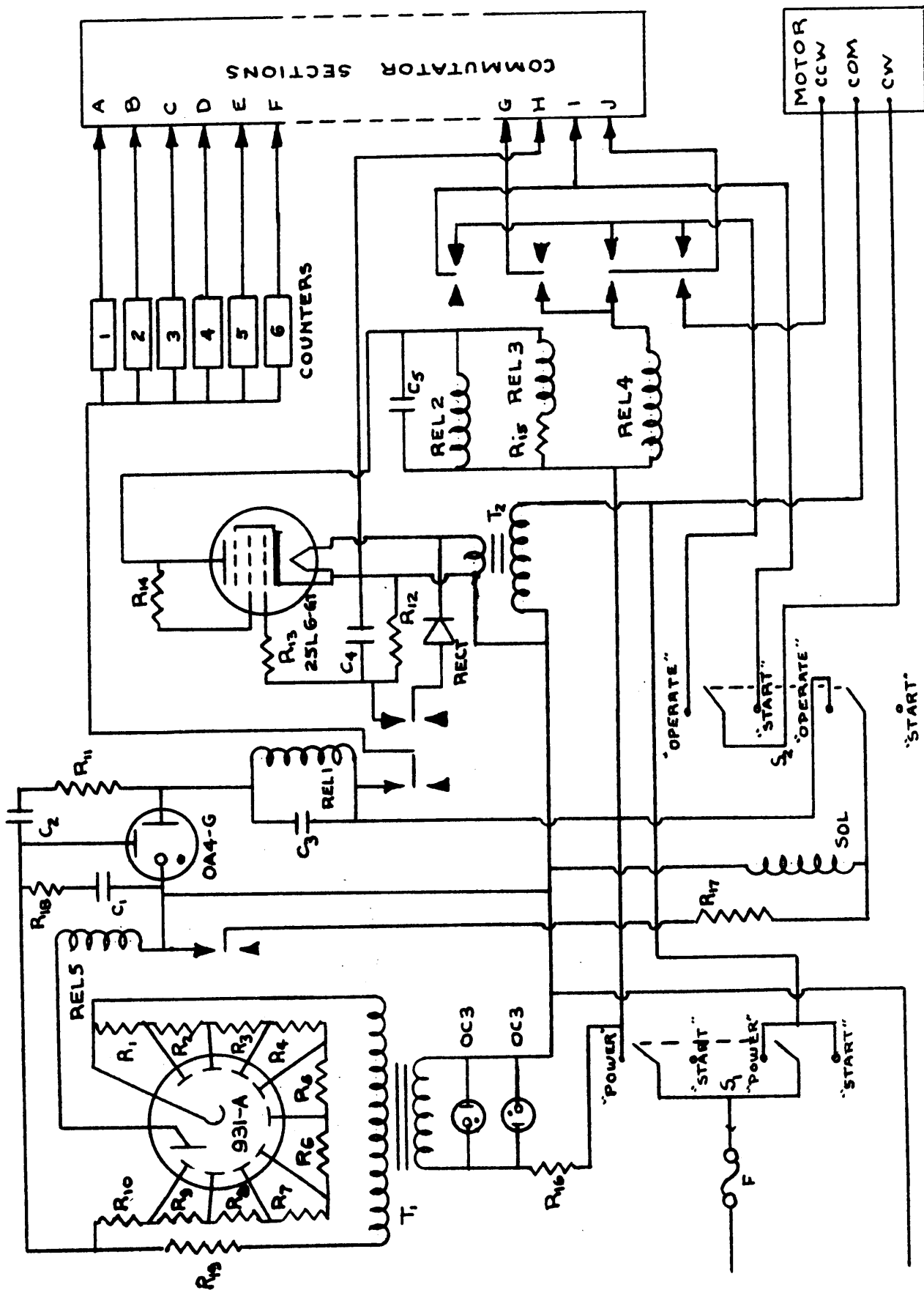

FIG. 16 INTEGRATOR CIRCUIT

COMPONENTS

- C₁ - Capacitor, Mica, 600v, 84000 $\mu\mu$ f
- C₂ - Capacitor, Mica, 600v, 1000 $\mu\mu$ f
- C₃ - Capacitor, Paper, 600v, 2 μ f
- C₄ - Capacitor, Electrolytic, 25v, 4000 μ f
- C₅ - Capacitor, Electrolytic, 450v, 16 μ f
- F - Fuse, .75 amp
- R₁-R₉ - Resistors, Carbon, .1 meg, $\frac{1}{2}$ watt
- R₁₀ - Resistor, Carbon, .15 meg, $\frac{1}{2}$ watt
- R₁₁ - Resistor, Carbon, .1 meg, $\frac{1}{2}$ watt
- R₁₂ - Resistor, Carbon, 1000 ohms, $\frac{1}{2}$ watt
- R₁₃ - Resistor, Carbon, 15000 ohms, $\frac{1}{2}$ watt
- R₁₄ - Resistor, Carbon, 1000 ohms, $\frac{1}{2}$ watt
- R₁₅ - Resistor, Carbon, 6600 ohms, 1 watt
- R₁₆ - Resistor, Ceramic, 100 ohms, 10 watts
- R₁₇ - Resistor, Ceramic, 150 ohms, 10 watts
- R₁₈ - Resistor, Carbon, .1 meg, $\frac{1}{2}$ watt
- R₁₉ - Resistor, Carbon, 50000 ohms, $\frac{1}{2}$ watt
- Rel 1 - Relay, Double Pole Double Throw, 5000 ohms
- Rel 2 - Relay, Single Pole Double Throw, 2500 ohms
- Rel 3 - Relay, Single Pole Double Throw, 2500 ohms
- Rel 4 - Relay, Double Pole Double Throw, 115v AC
- Rel 5 - Relay, Single Pole Double Throw, .00075 amps
- Rect. - Rectifier, Selenium, 100v

Components (cont'd)

- S₁ - Switch, Double Pole Double Throw, Center off,
115v, 2 amps
- S₂ - Switch, Double Pole Double Throw, 115v, 2 amps
- T₁ - Transformer, 115v pri., 1100v sec.
- T₂ - Transformer, 115v pri., 25v sec.
- 25L6-GT - Power pentode
- 0A4-G - Gas triode
- 931-A - Photomultiplier tube
- 0C3 - Voltage reference tube, 105v
- Sol - Solenoid, 115v AC, 1 inch stroke
- Counters - 115v AC
- Motor - 110v AC, 1 rpm
- A-J - Commutator sections

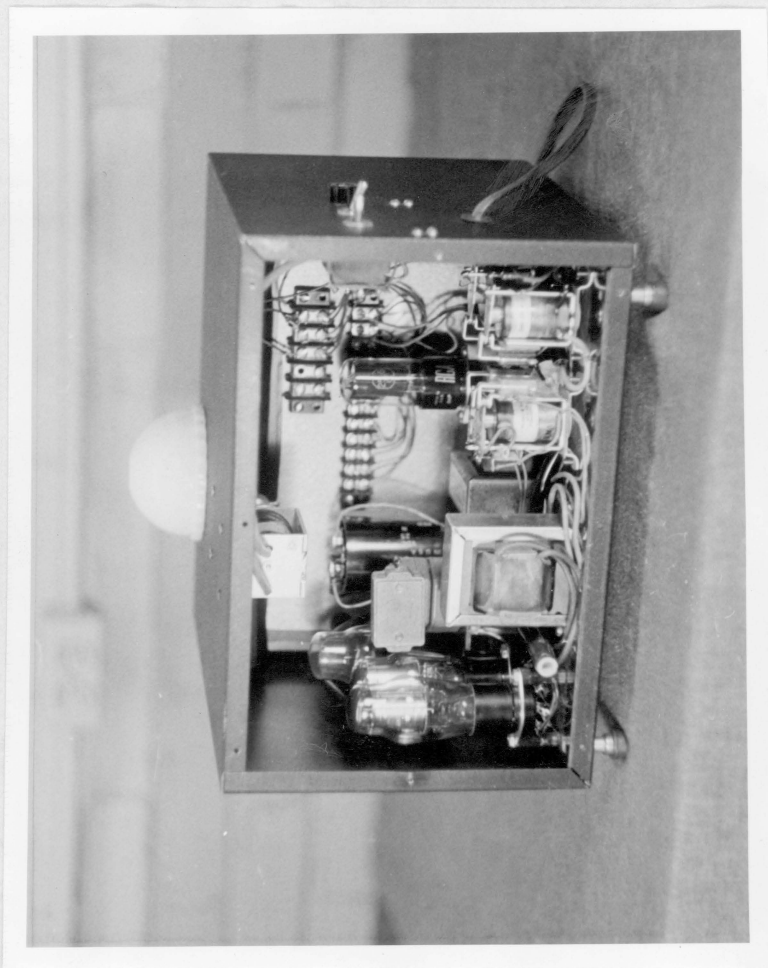

FIG. 17 Integrator Wiring

CALIBRATION AND TESTING OF THE INSTRUMENT

It is necessary to determine the exact value of each pulse registered on the six counters. The units chosen are watt-seconds, or joules, per square centimeter per count and lumen-seconds per square centimeter per count, the first unit being of primary interest to the physicist and the second of greater interest to the plant physiologist. It is also important to include in the calibration procedure determinations of the reliability of the instrument under varying conditions.

Reliability Tests

The first variable to be determined was the effect of the angle of incidence of the light source on the counting period of the integrator. The light source was maintained at a constant intensity by control of the current. The source was positioned at various angles θ from the normal to the top surface of the integrator and the counting period measured at each position. All counting periods were determined with a stopwatch accurate to 1/10 second and were the average of 10 counts.

The resulting data is shown in Table 2 and plotted in Fig. 18. This curve is approximately of the form:

$$R = a + b \cos \theta$$

Table 2
Variation of Counting Period with Angle of Incidence

<u>Angle θ</u>	<u>Period (Sec.)</u>	<u>Relative Rate</u>
0	2.00	100
13	2.08	96.1
31	2.31	86.7
43	2.52	79.4
54	3.04	65.8
61	3.56	56.2
74	4.34	46.1
81.2	5.31	37.6
82.6	5.49	36.4
86.3	5.99	33.4
87.1	6.34	31.5
87.8	6.42	31.1
90	6.81	29.4
94.4	7.66	26.1
98.8	23.8	8.4

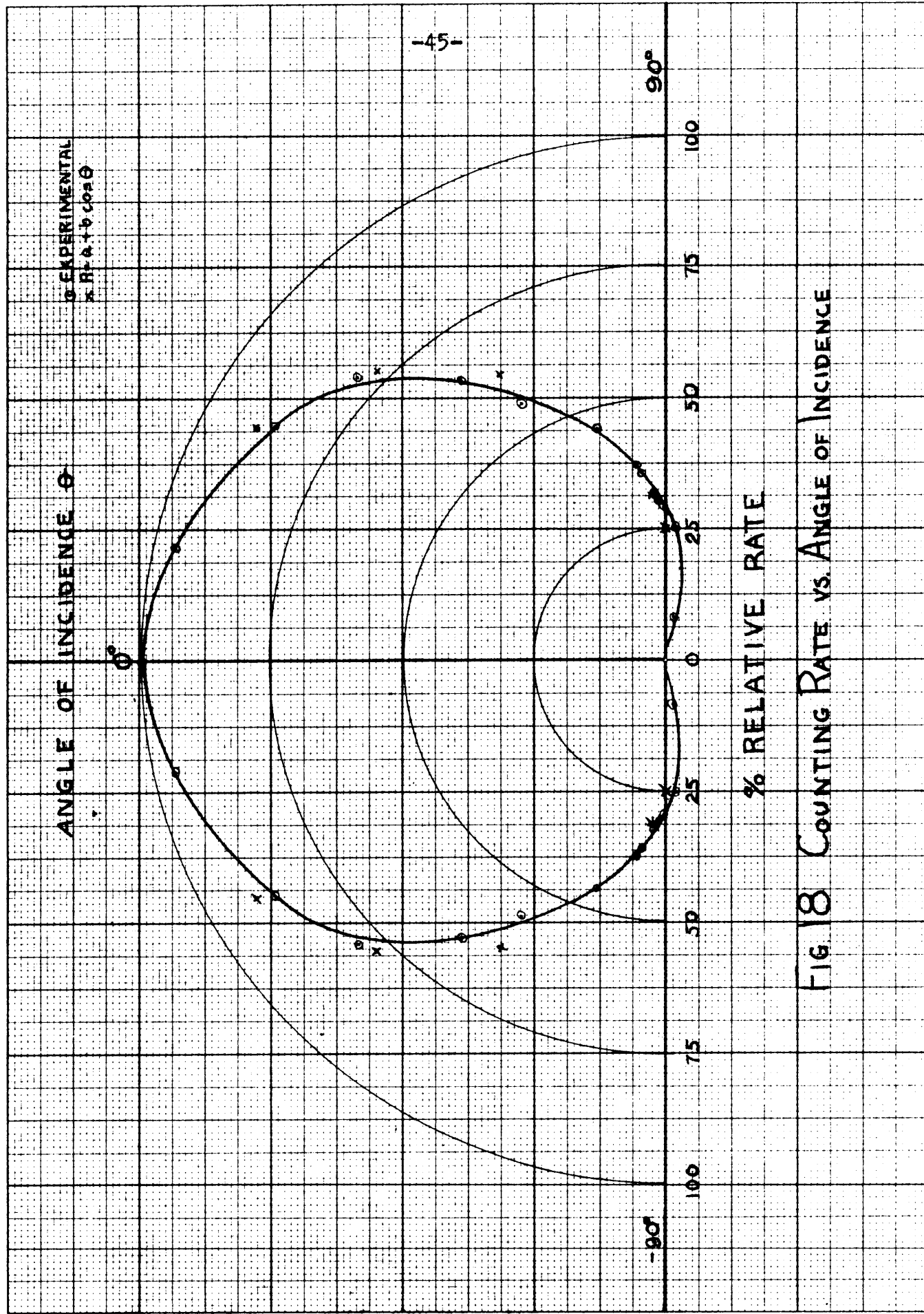

FIG 18 Counting Rate vs. Angle of Incidence

This also is plotted for the arbitrary constants $a = 25$ and $b = 75$. This indicates that for any angle of incidence within 40 degrees of the normal the integrator will register 80% or better of the true light intensity. The hemispherical dome is not as effective at light collection as a spherical receiving surface but is appreciably more receptive than a diffusing flat surface for which Lambert's cosine law holds good and should be adequate for the purpose of this instrument.

To test the variation of counting rate with intensity, the instrument was mounted at one end of an optical bench. The light source, a 300 watt frosted incandescent lamp, was mounted on the optical bench, but covered with a light shield which prevented the light source from illuminating anything but the dome of the integrator. This light source could then be considered as a point source, and the intensity of the light striking the integrator would be inversely proportional to the square of the distance from the source to the integrator. By varying this distance the intensity of the light can be controlled very accurately.

The current of the light source was fixed so that at the 40 centimeter distance the light intensity was about maximum for the filter being tested. As the light source was moved away the intensity declined to a point far below that measured by this filter. The counting rate at each

distance was determined and the data shown in Fig. 19. The counting period was plotted against the square of the distance. The points lie in a straight line and therefore the counting rate is linear with the intensity of the incident light.

The stability of the counting period under variations of line voltage was determined. The light intensity was held constant and the variation of counting period with line voltage measured. The results of this test are shown in Table 3.

Table 3
Variation of Counting Period with Line Voltage

<u>AC Line Voltage</u>	<u>Counting Period (Sec.)</u>
105	8.48
107	7.94
110	7.57
112.5	7.40
115	7.13
117.5	6.89
120	6.58

Below 111 volts the control circuit was unable to switch in less dense filters. The instrument is sensitive to voltage variations, a four percent voltage change varying the period by about six percent, but this is not

FIG. 19 COUNTING PERIOD
VS.
SOURCE DISTANCE SQUARED

COUNTING PERIOD (SEC)

SOURCE DISTANCE SQUARED (CM)²

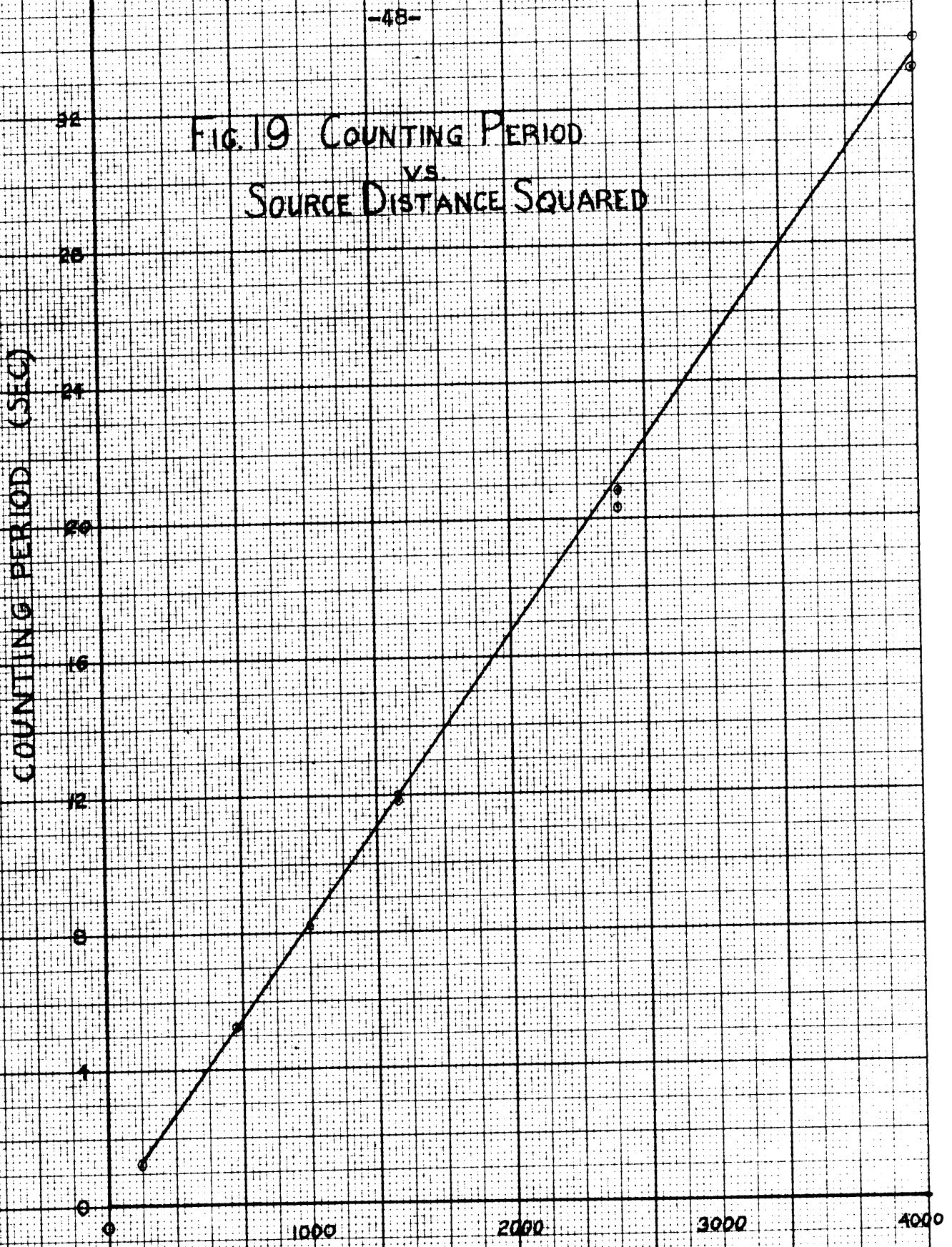

NO. 340 - 20 DIETZGEN GRAPH PAPER.
20 X 20 PER INCH
EUGENE DIETZGEN CO.
MADE IN U. S. A.

considered to be too detrimental since the voltage in any location will average out to a constant over the period of a day.

Filter Density Relations

In order to obtain a calibration of each filter, it was decided first to determine the ratios of the filter densities as measured by the photomultiplier tube. This would give a relative value for each filter. One filter could then be calibrated in absolute measurement and all others calculated to absolute values.

The relative counting rates for the filters were determined by measuring the counting rate at a fixed light intensity on one filter. The intensity was held constant while the next filter was manually switched into position. The rate for the new filter was then determined. Since the intensity was constant and only the filter changed, the ratio of the counting rates is proportional to the transmission of the filter as measured by the photosensitive surface. The resulting data are tabulated in Table 4.

This relative value was checked by plotting the period against the square of the distance for a given source current. The intensity range was such that two filters were used in the same series of measurements. See Fig. 20.

The determination of the energy units was made from a National Bureau of Standards radiation standard which

Table 4

Relative Filter Transmission

Source: 300w Frosted Bulb 24.8cm from Dome

<u>Source</u> <u>(Amps)</u>	<u>Filter</u>	<u>Period</u> <u>(Sec.)</u>	<u>Filter</u>	<u>Period</u> <u>(Sec.)</u>	<u>Trans.</u> <u>(%)</u>	<u>Avg. Trans.</u> <u>(%)</u>
--------------------------------	---------------	--------------------------------	---------------	--------------------------------	-----------------------------	----------------------------------

With limiting filter:

1.16	1	1.38	2	12.57	11.0	
1.20	1	.89	2	8.06	11.0	10.9
1.24	1	.63	2	5.96	10.6	
1.44	2	1.13	3	10.33	10.9	
1.48	2	.89	3	7.81	11.4	11.2
1.52	2	.71	3	6.29	11.3	
1.80	3	1.32	4	10.85	12.2	
1.86	3	.98	4	7.89	12.4	12.3
1.90	3	.83	4	6.76	12.3	
2.40	4	1.15	5	9.41	12.2	
2.48	4	.91	5	7.55	12.1	12.2
2.54	4	.81	5	6.55	12.4	

Without limiting filter:

2.36	5	1.21	6	7.89	15.3	
2.42	5	.99	6	6.22	15.9	15.5
2.54	5	.71	6	4.60	15.4	

FIG. 20 EFFECT OF FILTER CHANGE
ON
COUNTING PERIOD
VS.

SOURCE DISTANCE SQUARED

○ FILTER NO. 2

x FILTER NO. 3 (CALCULATED)

COUNTING PERIOD (SEC)

SOURCE DISTANCE SQUARED (CM)²

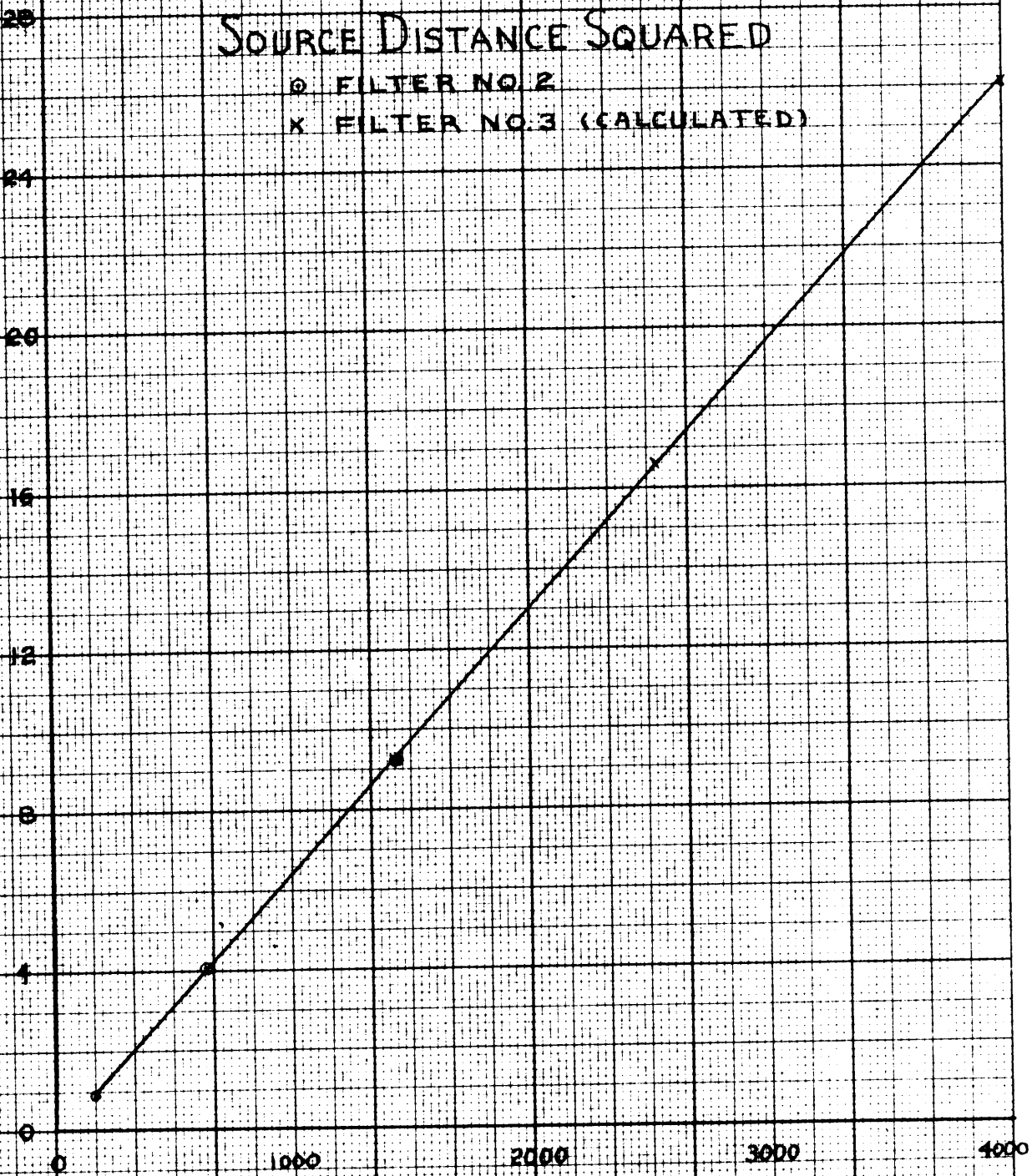

delivers 77×10^{-6} watt per square centimeter at a 200cm distance when operated at 350 milliamperes and 107.91 volts. This lamp was operated under the specified conditions under the shield to eliminate room light. The light intensity of the radiation standard was so low that it was necessary to remove the limiting filter in order to use filter No. 1. The average of five counting period determinations was 4.98 seconds per count. The incident energy per count, J_0 , without the limiting filter is:

$$J_0 = 77 \times 10^{-6} \times 4.98$$
$$J_0 = 38.4 \times 10^{-6} \text{ joules per cm}^2 \text{ per count}$$

The ratio of counting period with the limiting filter to the period without the limiting filter was found to be 6.48/.748. The energy value of the counting unit, J_1 , on the first filter is:

$$J_1 = 38.4 \times 10^{-6} \times \frac{6.48}{.748}$$
$$J_1 = 333 \times 10^{-6} \text{ joules per cm}^2 \text{ per count}$$

The energy value for filter No. 2 is:

$$J_2 = \frac{J_1}{T_{12}}$$

where T_{12} is the transmission of filter No. 2 with respect to filter No. 1.

$$J_2 = \frac{333 \times 10^{-6}}{.109}$$

$$J_2 = 305 \times 10^{-5} \text{ joules per cm}^2 \text{ per count}$$

Calibration of other filters may be computed in the same manner. The results are summarized in Table 5.

To calibrate the instrument in terms of lumen seconds per count, a National Bureau of Standards certified lamp was used under its standard conditions, 1.624 amperes at 115 volts using filter No. 1 with the limiting filter. The luminous flux of the lamp is 3150 lumens at these conditions.

At 200cm the luminous flux on a 3 inch diameter dome is:

$$3150 \times \left(\frac{1}{2} \times 3 \times 2.54\right)^2 \pi / 4\pi(200)^2 = .287 \text{ lumen}$$

The average counting period is 1.36 seconds at this illumination and the calibration of filter No. 1 for units of intensity, I_1 , is:

$$I_1 = \frac{.287 \times 1.36}{45.5}$$

$$I_1 = .00858 \text{ lumen-sec per cm}^2 \text{ per count}$$

The calibration of the other filters for units of intensity may be calculated in the above manner. These are also listed in Table 5.

Since one foot-candle is equal to one lumen per square

Table 5
Calibration of Filters

$$J_0 = 38.4 \times 10^{-6} \text{ joules per cm}^2 \text{ per count}$$

$$J_1 = 333 \times 10^{-6} \text{ joules per cm}^2 \text{ per count}$$

$$I_1 = 8.58 \times 10^{-3} \text{ lumen-sec per cm}^2 \text{ per count}$$

<u>Filter</u>	<u>Trans. (%)</u>	<u>J_n</u>	<u>I_n</u>
1	100	.000333	.00858
2	10.9	.00305	.0787
3	11.2	.0273	.703
4	12.3	.222	5.71
5	12.2	1.82	46.9
6	15.5	11.7	302

foot, the units may be expressed in terms of foot-candles
by the equation:

$$.00858 \times 930 = 7.98 \text{ foot-candle-sec per count}$$

SUMMARY

It was stated in the introduction that the purpose of this project was to design and construct a sunlight integrator which would have wide intensity range, reliability under normal operating conditions, and moderate cost.

If the minimum sensitivity for the first filter is arbitrarily chosen as one-tenth the dark counting period, which is in excess of three hundred seconds, the minimum detectable light intensity would be:

$$.00858/30 = .000286 \text{ lumen per cm}^2$$

This is equivalent to an intensity of .256 foot-candle for a 30 second counting period.

The light intensity equivalent to a maximum rate of one count per second on the No. 6 filter may be calculated from the value of this filter to be 302 lumen per square centimeter. The intensity range of the instrument is approximately:

$$302/.000286 = 1.05 \times 10^6$$

This is a very wide intensity range and should be quite adequate for sunlight measurements. The instrument of Sprague and Williams¹⁶ has an estimated range of about 10^3 and that of Somers and Hamner¹⁵ is limited to a 100 foot-candle minimum intensity.

The sunlight integrator has been given continuous operational trials exposed to the sunlight through the laboratory window and found to function satisfactorily over the period of a month. The black housing was observed to heat while exposed to direct sunlight. It is therefore planned to paint the housing a light color and provide air vents for cooling before placing the instrument on field trial in the greenhouse.

The instrument has demonstrated a reasonable degree of reliability, ample for field measurements though not sufficient for a critical research instrument. The major sensitivity of the instrument is toward the ultraviolet end of the spectrum, but the substitution of a red sensitive photomultiplier tube and insertion of the proper filter would enable the instrument to detect and integrate any desired wavelength band of light.

The integrator was planned to be of moderate cost and the economy has been maintained. It may be estimated that the component parts for the instrument could be purchased for less than \$200.00 and construction costs should not be excessive.

ACKNOWLEDGEMENTS

The author would like to express his sincere appreciation to all those who have helped make this work a success. He is especially indebted to Dr. H. Y. Loh, not only for his suggestion of the project, but also for his continuing help and assistance in the design and procurement of components for the instrument. He would like to thank Dr. J. H. Tinga of the Horticulture Department for his interest in the project and for supplying some of the parts for the integrator. To Dr. F. L. Robeson he is greatly indebted for his many helpful suggestions in the editing of the manuscript. He wishes also to thank Mr. L. Barnett for making many small parts for the apparatus.

He would like to express his gratitude to the personnel of the Poly-Scientific Corporation for their donation of the commutator and brush assembly and for their helpful suggestions for its design.

To his wife he is deeply grateful for her understanding and encouragement throughout the project. Finally to Mrs. M. C. Hoover and Mrs. R. M. Georgallis he would like to express his sincere thanks for their care and thoughtfulness in the typing of this thesis.

BIBLIOGRAPHY

1. Allen, A. H., and K. J. McCree, "Integrating Meters for Comparing Light Intensities in Plant Growth Studies", Journal of Scientific Instruments, 32, 422-424 (1955).
2. Babcock, H. W., "Integrating Photometer for Low Light Levels", Journal of the Optical Society of America, 40, 409-411 (1950).
3. Bahls, W. E., and C. H. Thomas, "A new Gas-filled Triode", Electronics, 11, 14 (1938).
4. Ditchman, J. P., "Light and Agriculture", Illumination Engineering, 46, 276-282 (1951).
5. Douglas, C. A., "Visibility Measurements by Transmissometer", Electronics, 20, 106-109 (1947).
6. Giovanelli, R. G., "An Omnidirectional Photometer of Small Dimension", Journal of Scientific Instruments, 30, 326-328 (1953).
7. Hariharan, P., and M. S. Bhalla, "A Wide Range Recording Logarithmic Photometer Circuit", Journal of Scientific Instruments, 33, 69-71 (1956).
8. Kuper, J. B. Horner, F. S. Brackett, and Maynard Eichler, "Integrating Photoelectric Meter", Review of Scientific Instruments, 12, 87-90 (1941).
9. Lampkin, G. F., "A Simple AC Voltage Regulator", Electronics, 10, 30 (1937).
10. Launer, H. F., "Exposure Meter for Precision Light Dosage", Review of Scientific Instruments, 20, 103-109 (1949).
11. Miller, O. E., "Integrating Light Meter for Fading Tests", Journal of the Optical Society of America, 42, 661-662 (1952).
12. Mitchell, K. J., "Lighting in Relation to Plant Growth", Light and Lighting, 43, 345-353 (1950).
13. Petersen, H., Private Communication

Bibliography (cont'd)

14. Rentschler, H. C., "An Ultraviolet Light Meter", Transactions of the American Institute of Electrical Engineers, 49, 576-578 (1930).
15. Somers, G. F., and K. C. Hamner, "Phototube-type Integrating Light Recorder", Plant Physiology, 26, 318-330 (1951).
16. Sprague, V. G., and E. M. Williams, "An Inexpensive Light Recorder", Plant Physiology, 16, 629-635 (1941).
17. Sprague, V. G., and E. M. Williams, "A Simplified Integrating Light Recorder for Field Use", Plant Physiology, 18, 131-133 (1943).
18. Wallace, R. H., "Methods of Sampling Visible Radiation", Plant Physiology, 12, 647-666 (1937).

**The vita has been removed from
the scanned document**