



M A S T E R P L A N

1983

1993

VIRGINIA POLYTECHNIC INSTITUTE AND STATE UNIVERSITY

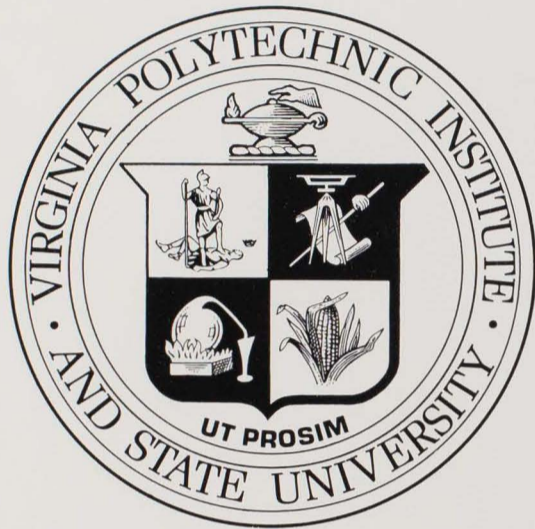

1983-1993 Master Plan
Concepts, Data, and Strategies for Implementation

Office of the University Architect
Virginia Polytechnic Institute & State University
Blacksburg, Virginia

LD
5655
A4
1984b
c.7
Folio

Table of Contents

Acknowledgments	iv
Foreword	v
Introduction	vi
Illustrative Master Plan	vii
VPI&SU 1983	1
Location of Facilities	2
Campus Plan 1983	4
Campus Development	6
Building Use	8
Concept	13
Issues	14
Incremental Infill Construction	16
Increment Capacity	18
Perceptual Analysis	20
Open Space Analysis	24
Planning Concepts	26
Energy Concepts	30
Communication Concepts	34
Master Plan	37
Circulation	39
Pedestrian	40
Handicapped	46
Bicycle	48
Bus	52
Vehicular	54
Parking	58
Safety	61
Health and Safety	62
Emergency Response	66
Lighting	70
Landscape	73
Site Data	74
Site Analysis	75
Climate	76
Open Space Use	78
Trees	82
Landscape Development Plan	84
Infrastructure	87
Infrastructure System	88
Steam Tunnel / Chilled Water	90
Storm Drainage	92
Sanitary Sewer	94
Water	96
Electricity	98
Telephone	100
Computer	102
Implementation	105
Implementation Process	106
Project Alternatives	108
Examples of Application	110
Appendices	113
Building Reference	114
Master Plant List	115

Acknowledgments

I am particularly grateful to Dr. Alfred Krebs, who was Vice President for Administration and Operations at the initiation of this project, for accepting the recommendation of Dean Julio San Jose, then Dean of the College of Architecture, that I be involved in the development and implementation of this Master Plan. Dr. Krebs' enthusiastic and unqualified support as well as the commitment of Dr. William Lavery, President, and the University Administration made possible the evolution of the plan and the publication of this document. I would also like to acknowledge the invaluable contribution of Dean Charles Burchard, FAIA, and the College of Architecture for the initial development and introduction of the "infill concept" portion of this Master Plan. It was this work that stimulated the interest and support of the University Administration and resulted in funding for the plan's development by the General Assembly of the Commonwealth.

In the fall of 1981, Dr. Krebs retired, and Dr. William Van Dresser succeeded him as Vice President for Administration and Operations. I wish to thank Dr. Van Dresser for his confirmation of the Administration's support of the Master Plan as well as his commitment to the qualitative as well as the quantitative issues involved in its implementation.

Special recognition also belongs to my good friend, Bill Sterrett, retired Director of Physical Plant, whose initial skepticism about the

plan in general and architects in particular provided the impetus for trying a little harder.

I also wish to acknowledge the professional contributions of Ben Johnson and Diana Tracey, as well as Ken Baker, J.B. Sutphin, and Noni Parsons, all colleagues in the University Planning Office. Given the demands on space, time, and resources involved in doing this project in-house, I thank the total planning staff for their patience and understanding. I am especially grateful to Diana Tracey, AIA, without whose professional dedication, commitment, hard work, and perseverance this project might "never" have been completed.

Finally, I must acknowledge the sacrifice of my children Maria, Lisa, and Elizabeth for all the weekends and evenings lost, and my wife Anne Cheney, who as a writer, is all too familiar with such things.

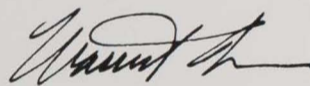

Warren R. Kark, AIA
University Architect

Foreword

The objective of this plan is to define a matrix of concerns and criteria to guide the incremental response over time to the changing needs of Virginia Polytechnic Institute and State University. The plan is not a statement of a preconceived, idealized future. Rather, it reflects a methodology for working the whole canvas, building to reinforce and complement what is.

This document articulates the University's concerns and criteria in terms of generic planning issues, the purpose of which is to provide a basis for evaluating the many alternatives which will surface throughout implementation. Preventing construction of ill-conceived buildings, justified on the basis of expedient solutions to immediate problems, is clearly more critical to the quality of the University environment and its future than is the alternative.

This plan charts a future course which is sympathetic to the past and present. Recognizing the evolution of the University campus, and understanding the relationship between its current mission and the function and dysfunction of the present physical plant, represent the starting point for this undertaking.

Key to this process are four primary issues: PRESERVATION, INTEGRATION, REGENERATION, and ADAPTATION. In order to understand the importance and relevance of the Virginia Tech campus, studies were conducted of the physical, programmatic and philosophical evolution from its founding in 1872 as a small land grant school to its status today as a comprehensive state university. The resultant understanding of the "historical context" led to an identification of relevant places and spaces of the campus — the elements which make Virginia Tech unique.

PRESERVATION of the quad concept, the Drill Field and the unique architectural and spatial qualities of the campus is imperative, if meaningful continuity is to be ensured. In the 1960s, Tech suffered a compromise of these values. Now the task is to re-establish them within the parameters of a contemporary, energy-efficient construction technology which responds to the needs of evolving and

sophisticated programmatic constraints.

Functional and aesthetic INTEGRATION of new construction into the existing campus fabric presents perhaps the greatest challenge of this plan — a plan based on the concept of incremental infill construction which expands the criteria for project development beyond questions of simple programmatic need. Now design criteria must encompass broader qualitative and quantitative planning issues.

REGENERATION reflects a commitment to the vitality of the existing campus. Too frequently new campus structures are planned at the expense of existing space. But this plan obliges the development and placement of increments of construction which recognize and address existing building deficiencies. It is a strategy which differentiates space according to generic use, technological demands, and programmatic exceptions. These factors in turn allow the discreet placement of increments to achieve the greatest functional impact of both new and existing space.

Finally, new construction must be ADAPT-ABLE. For all the variable factors in campus planning, there is one absolute: Needs will change. New facilities must accommodate programmatic expansion and contraction, technological innovation, and constantly evolving teaching and research methods.

Commitment and perseverance in these areas will ensure a future campus which appropriately embodies its past, present, and future.

Introduction



Virginia Polytechnic Institute and State University (popularly known as Virginia Tech) opened its doors as Virginia Agricultural and Mechanical College, a state land-grant college, on October 1, 1872. In less than 70 years, it had become the largest university in the state. Today Virginia Tech's enrollment exceeds 21,000 students in eight colleges: Arts and Sciences, Agriculture, Architecture, Business, Engineering, Education, Human Resources, and Veterinary Medicine.

The University today fulfills in many ways its three-part mission of education, research and extension. These activities include nationally recognized graduate and undergraduate programs in business, engineering, architecture, and international agriculture. Private industry and government contribute millions of dollars for research. And, in keeping with its mandate of service to the Commonwealth, Virginia Tech operates an Extension Division which reaches virtually every community.

Virginia Tech also makes its collective faculty expertise available to the state and nation by participating in economic and industrial planning. From the main campus in Blacksburg, the University's wealth of educational and research resources continually add to the diverse and competitive world of high-technology development.

The most important product of Virginia Tech's activities is the education of young people. While 80 percent are Virginians, representing every town and county in the Commonwealth, the University enrollment includes students from most states and many foreign countries. This diversity in Blacksburg contributes to Virginia Tech's standing as a comprehensive university.

Illustrative Master Plan

existing building 
infill increment 



VPI & SU 1983

An understanding of the past and present is essential to the articulation of a strategy for achieving a meaningful future.

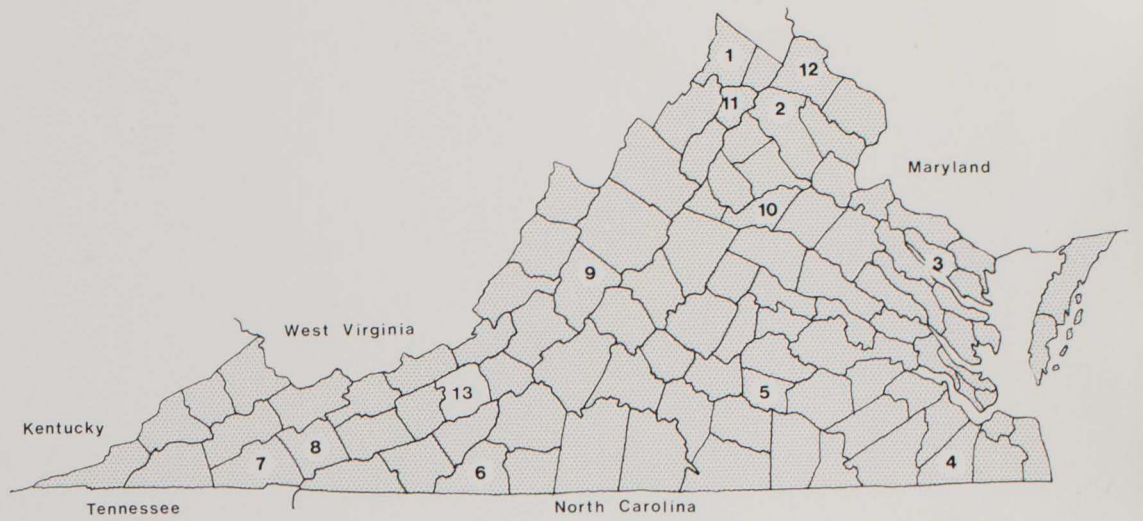

Location of Facilities

Virginia Polytechnic Institute and State University is the largest university in Virginia, a state of 5.5 million people who live in a range of settings from small farming communities to dense urban regions. Virginia's boundaries encompass three distinct physiographic regions and additional sub-areas distinguished by diverse soil and climatic conditions under which the state's agricultural producers operate.

To fulfill its mission of teaching, research, and extension, Virginia Tech maintains land holdings throughout the state. The University's first land acquisition occurred in 1872, when the former Preston and Olin Institute bestowed a lone building and five acres to the newly-chartered Virginia Agricultural and Mechanical College. Since then, the University has obtained various parcels of land contiguous to the initial plot and throughout the Commonwealth. By 1940, the University owned approximately 1,000 acres. That amount increased to some 2,500 acres by 1950 and more than doubled again by 1960. The University's 1982 land inventory indicates some 5,800 acres in ownership, with additional parcels leased to supplement various research and extension programs.

Land holdings throughout Virginia (1) include:

1. Winchester Research Laboratory (Frederick County), 130 acres.
2. Virginia Forage Research (Fauquier and Loudoun Counties), 419 acres.
3. Eastern Virginia Research Station (Richmond County), 54 acres.
4. Tidewater Research Station and Continuing Education Center (Nansemond County), 89 acres.
5. Southern Piedmont Research Station and Continuing Education Center (Nottoway County), 1,100 leased acres.
6. Reynolds Homestead Research and Continuing Education Center (Patrick County), 710 leased acres.
7. Southwest Virginia Research Station (Washington County), 208 acres.
8. Geology Field Station (Smyth County), 64 acres.
9. Shenandoah Valley Research Station (Rockbridge and Augusta Counties), 627 acres.

1. Virginia

10. Piedmont Research Station (Orange County), 43 acres.
11. Northern Virginia 4-H Center (Warren County), 229 acres.
12. Marion duPont Scott Equine Medical Center (Loudoun County), 208 acres.
13. Virginia Tech main campus (Montgomery County), 2,188 acres.

Montgomery County (2), located in mountainous Southwest Virginia, surrounds the main campus and town of Blacksburg. Large portions of the Jefferson National Forest occupy the county's northern section and form one border of the town. The remaining edges of town are characterized by rolling

farmland and pastures, with the Blue Ridge and Allegheny Mountains dominating the distant horizons (5).

Valuable research sites in Montgomery - County are within easy driving distance of Virginia Tech and, to further meet its research and instructional needs, the University operates facilities at:

14. Price's Fork Research Station, 118 acres.
15. Turkey Research Station, 80 acres.
16. Horticulture Farm, 216 acres.
17. Fishburn Property, 1,132 acres.
18. Moore Farm, 246 acres.

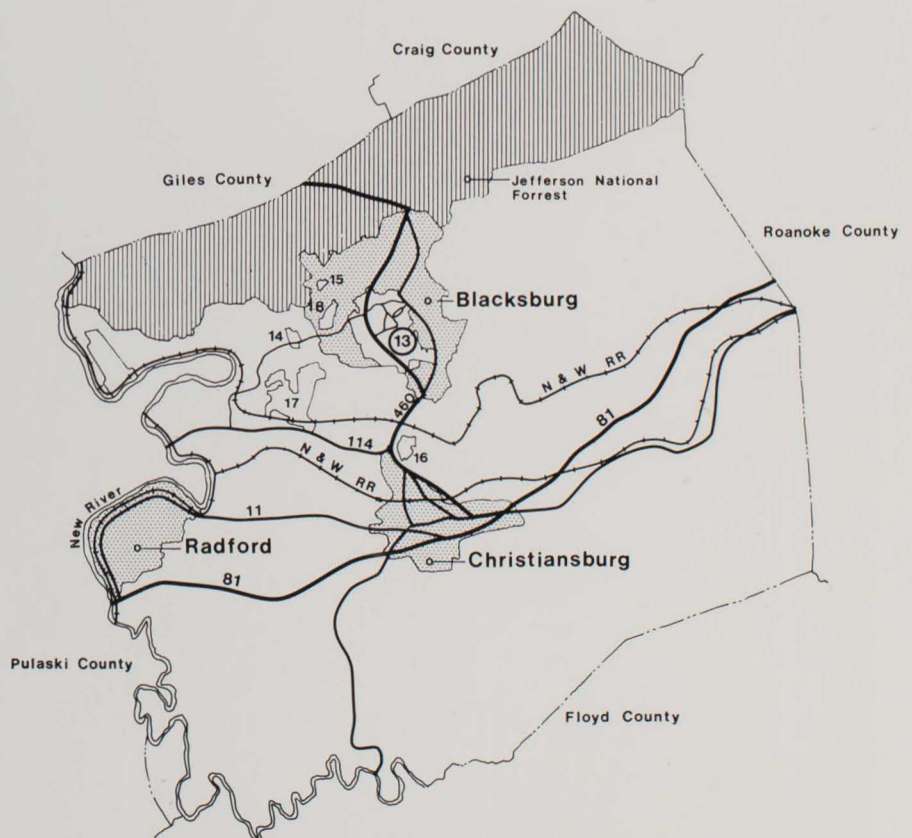

2. Montgomery County



3. Town edge



4. Rural edge

The lodestar of the University's efforts is Blacksburg, home to the main campus of Virginia Tech. The town (6) began in 1748 as Draper's Meadow, a tiny hamlet of farmers who braved the frontier and suffered the consequences, only one survivor living to tell of the Shawnee Indian raid that ravaged the town. But the pioneers persisted, and in 1798 landholder William Black petitioned the state General Assembly for a town charter. Blacksburg was born.

Vital to the town's subsequent growth was the founding in 1851 of a small Methodist "seminary of learning" for young men. In 1872 the school, Preston and Olin Institute, received two-thirds of Virginia's land-grant fund and became a state college. Virginia Agricultural and Mechanical College was born.

Since that time, the town and gown in Blacksburg have had great impact upon each other. During the 1870s, town residents found much to criticize about the college and the loose rein kept on its students. Fortunately, relations have warmed. Now the University and town cooperate on a wide range of issues affecting and benefiting both.

After several shifts in educational direction, prodigious growth in enrollment, and three name changes reflecting its true mission, Virginia Polytechnic Institute and State University has developed academic programs and research facilities regarded among the nation's best. The sprawling educational center occupies 2,188 acres, of which approximately 780 define the main campus (5). Another 1,150 acres serve the College of Agriculture in its teaching, research, and extension programs.

The symbolic boundary between Virginia Tech and the town of Blacksburg remains the Main Street/College Avenue area where the original Preston and Olin Institute stood (3). The rows of two-story shops along these two streets constitute a definable edge between the commercial sector of town and the park-like environment of the University campus. From there, the campus spreads over rolling landscape and blends with the farmland to the west (4). The Master Plan preserves this physical relationship to the town while fostering sensitivity to the rural character of the campus proper.



5.



6. Blacksburg

existing building 



- | | |
|-----------------------------------|--------------------------|
| 1. Mall Entry | 13. Ambler Johnston Quad |
| 2. War Memorial | 14. Campbell Quad |
| 3. Drill Field | 15. Eggleston Quad |
| 4. Greenhouse Road Entry | 16. Newman Quad |
| 5. Golf Course | 17. Pritchard Prairie |
| 6. Southgate Road Entry | 18. Intramural Fields |
| 7. College of Veterinary Medicine | 19. Tennis Courts |
| 8. Duck Pond | 20. Cowgill Plaza |
| 9. Upper Quad | 21. Library Plaza |
| 10. Patton Quad | 22. Dietrick Plaza |
| 11. Williams Quad | 23. College Avenue |
| 12. Agricultural Quad | |



7. Mall entry



8. War Memorial



9. Newman Quadrangle

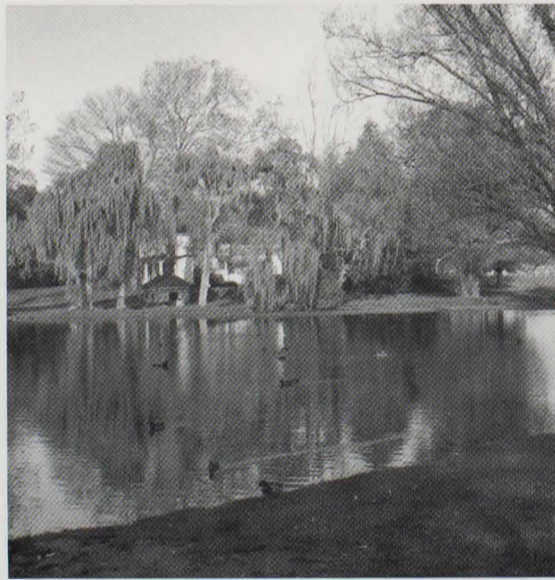

10. Duck Pond



11. Drill Field

Campus Plan Orientation

Visitors to Virginia Tech are struck immediately by its rural character, with lush vegetation and campus buildings spread over gently rolling terrain.

Most people use one of three main entries to arrive on campus. The Mall (1), an entrance from the town's Main Street, lies on a direct axis to the War Memorial (2) and Drill Field (3). The Greenhouse Road entry (4), leads past the golf course (5) and provides an elevated perspective of campus. The Southgate Road entry (6), a direct link to U.S. 460 Bypass, reinforces the rural perception of campus as it passes the Dairy Barns, College of Veterinary Medicine (7), and Duck Pond (8).

Most delightful of the campus spaces are quadrangles, which include Upper Quad (9), Patton Quad (10), Williams Quad (11), Ag Quad (12), Ambler-Johnston Quad (13), Campbell Quad (14), Eggleston Quad (15), and Newman Quad (16). Residential or academic buildings form the surround of these quads, which are used regularly for outdoor classes, informal gatherings, study, play, and sunbathing.

The informal recreation areas are the Drill Field (3), Pritchard Prairie (17), Duck Pond (8), intramural fields (18), and tennis courts (19). Their uses include intramural sports, band practice, and other outdoor events. The Duck Pond provides a park setting for picnicking, jogging, fishing, and ice-skating.

The more structured exterior spaces at Cowgill Plaza (20), Library Plaza (21), and Dietrick Plaza (22) are gathering places related to major circulation ways. They feature planters, benches, steps, walls, amphitheaters, and fountains.

As mentioned, College Avenue (23) is the common boundary with Blacksburg's commercial district, composed mostly of two-story storefronts.

Campus Development



12. General view of the campus, about 1891

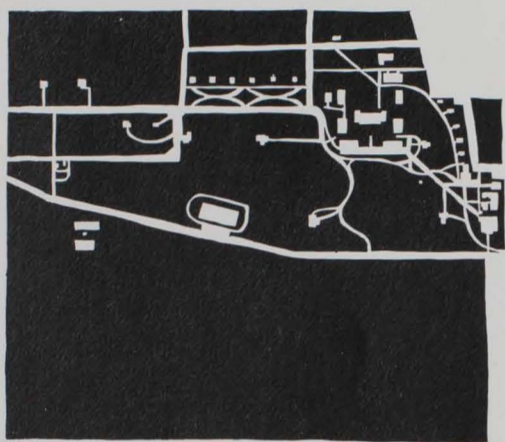

1908

The Morrill Land Grant Act of 1862 provided 30,000 acres of land to each state for every member of Congress representing that state. According to the act, the land was to be sold and the proceeds invested in bonds considered safe, but yielding no less than five percent interest. The interest income was to be used for the "endowment, support and maintenance of at least one college where the leading object shall be, without excluding other scientific and classical studies and including military tactics, to teach such branches of learning as are related to agriculture and mechanical arts ... in order to promote the liberal and practical education of the industrial class in the several pursuits and professions of life."

A Unionist state legislature laid claim to Virginia's land grant in 1864, but it wasn't until 1866 that an elected General Assembly arranged for sale of the 300,000-acre endowment, which a Cleveland investor bought for \$285,000. Long and embittered debate ensued over disposition of the fund. Twenty-four existing institutions in Virginia argued they were best suited to offer the curriculum provided for in the Morrill Act and the issue nagged the legislature for years. A compromise in 1872 finally split the earnings from the fund, with two-thirds earmarked to establish the Virginia Agricultural and Mechanical College.

The new school opened in October 1872 with

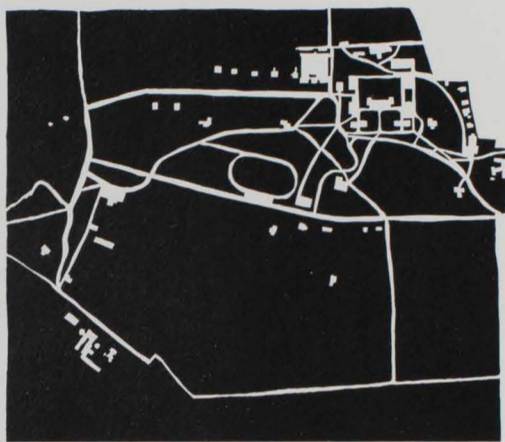

1921

one brick building, which stood near the present intersection of Main Street and College Avenue. Within two years, the college's governing board approved two new-academic buildings, two faculty houses, and a house for the president (now Henderson Hall). These brick academic buildings were the first structures in the current Upper Quad. The campus expanded greatly from 1891-1907 under the leadership of President John M. McBryde. An administration building, chapel, mess hall, YMCA building, and Agricultural Hall (now known as Price Hall) drew the campus westward and, in the YMCA and Agricultural Hall, introduced the use of native stone in campus buildings.

To reflect the college's work in scientific technology, the General Assembly in 1896 changed the name to Virginia Agricultural and Mechanical College and Polytechnic Institute. The college soon became popularly known as Virginia Polytechnic Institute, VPI, or Virginia Tech. It was formally renamed Virginia Polytechnic Institute with a legislative act in 1944.

Campus expansion was piecemeal from the end of McBryde's administration until after World War I, when an influx of veterans enrolled in classes and Julian A. Burruss began a 26-year period as president. Under Burruss, the Drill Field was given its oval definition and the now-dominant Collegiate Gothic stone architecture appeared around the Drill

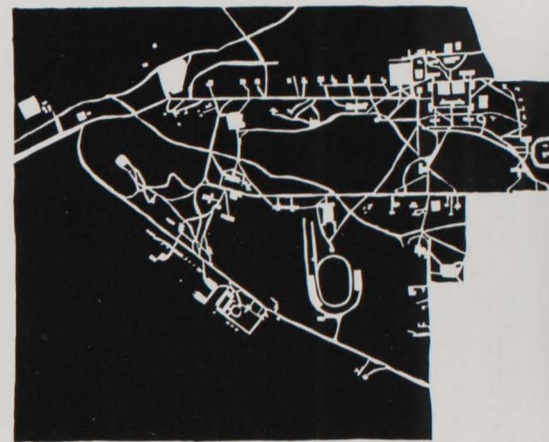

1931

Field's edge.

Another wave of applications arrived at the University following World War II, so many applications that an office of admissions was established to handle the deluge. VPI was caught unprepared for the large number of students, but a 15-year building program costing more than \$20 million sought to meet the demand. Additional dormitories in Upper Quad and Lower Quad doubled the University's housing capacity to nearly 4,000. Gaps in the academic quadrangles surrounding the Drill Field were filled and the trend towards outward expansion began in earnest with Randolph Hall, the Biochemistry and Nutrition Building, Vawter and Barringer dorms, Shultz Dining Hall, and Cassell Coliseum. The eastern edge of campus was radically changed during this period when, late in 1951, construction of the formal Mall entrance was begun. This linear approach to the new War Memorial Chapel was built at the expense of a large grove of trees and amid much controversy.

High-rise development was introduced in 1965 with the groundbreaking of Pritchard, Lee, and O'Shaughnessy dormitories on the campus perimeter. Accompanying the growth that occurred under President T. Marshall Hahn was a change in the institution's name in 1970 to Virginia Polytechnic Institute and State University. Construction from 1968-71 of Cowgill, Derring, Wallace, and Cheatham



13. Alumni Gateway, about 1908

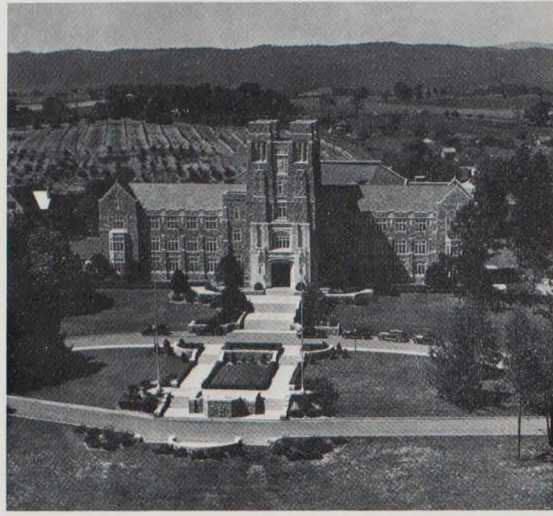

14. Burruss Hall, 1937

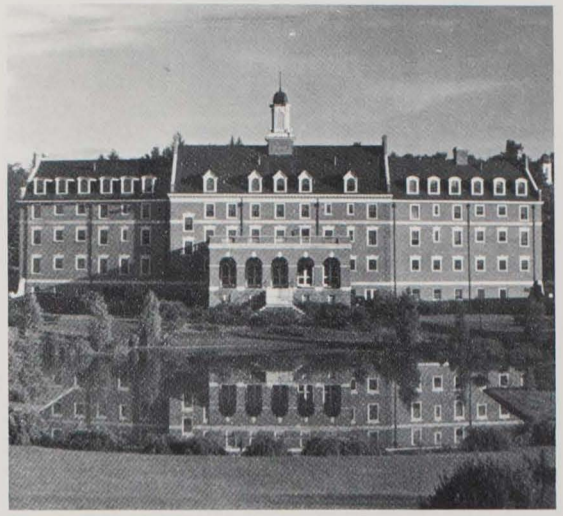

15. Continuing Education Center, 1942

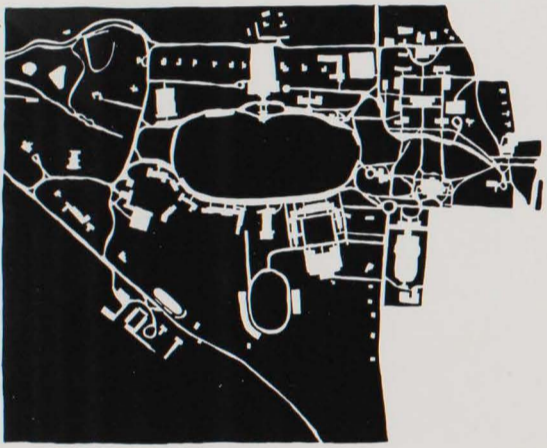

1945

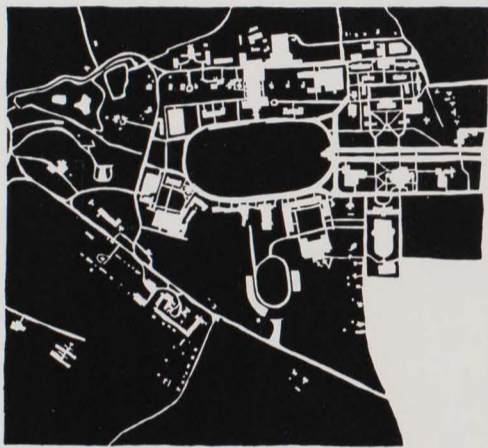

1954



1962

Halls and Ambler-Johnston dormitory contributed to the pattern of outward expansion that continued until adoption of this Master Plan a decade later. Beginning in 1983, the philosophy of campus development shifted toward preservation of existing facilities and major open spaces and exploration of more cost-efficient alternatives to new construction through building increments, which are connected to existing structures and take full advantage of infrastructure systems.



1972

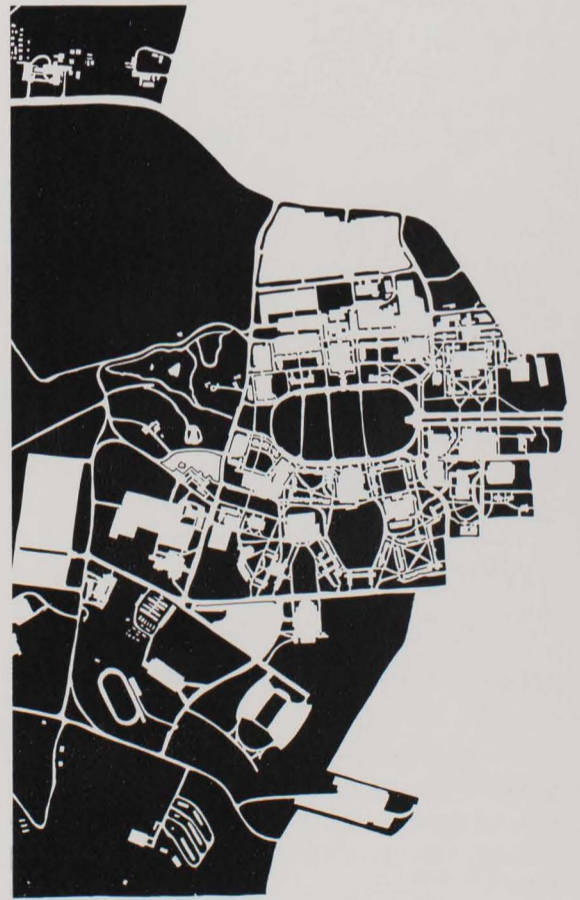

1983





17. Academic



18. Residential



19. Service



20. Athletic

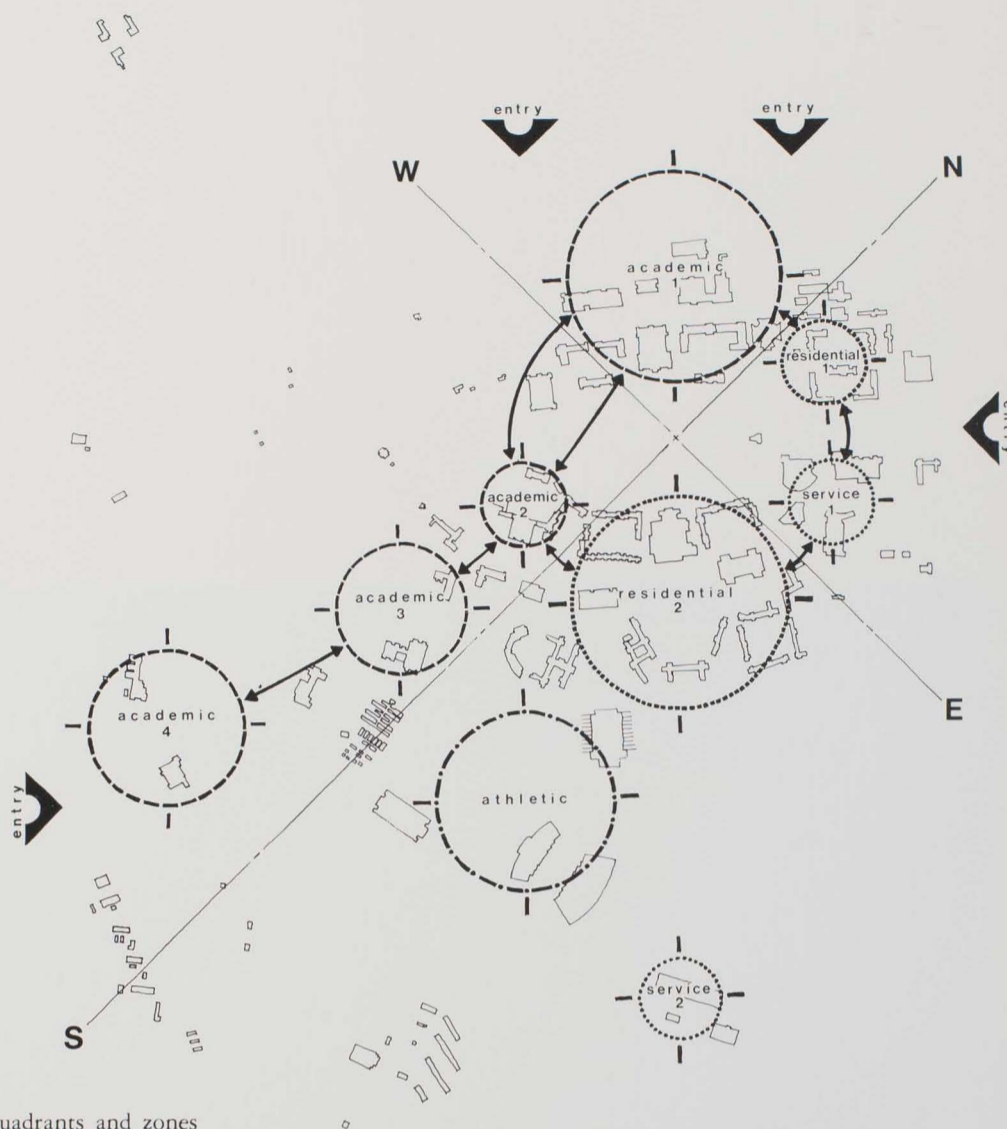

21. Campus quadrants and zones

The Virginia Tech campus divides functionally along the North/South axis, with the academic structures to the west and the residential, service, and athletic structures to the east. For planning and reference purposes, the campus is further divided into four quadrants organized around the central Drill Field and nine zones which, while not functionally exclusive, are spatially and functionally distinct.

The **Northwest Quadrant** contains a majority of the campus academic space. **Academic zone 1**, located in this quadrant, includes the Colleges of Arts and Sciences, Architecture, Business, and Engineering. Small components of Agriculture and Veterinary Medicine are located northwest of Prices Fork Road beyond the campus core.

The **Northeast Quadrant** is home to **Residential zone 1** (Upper Quad) and **Service zone 1**, which includes the University Bookstore, Continuing Education Center, Newman Library, Squires Student Center, and Henderson Hall (Student Health Services).

The **Southeast Quadrant** includes the majority of campus dormitory space in **Residential zone 2**. A portion of the College of Education also is located in this zone. The **Athletic zone** includes Cassell Coliseum, Rector Fieldhouse, Lane Stadium, and the tennis pavilion. **Service zone 2**, which includes Central Stores, Maintenance, and the Tech Police, also is located in this quadrant.

The **Southwest Quadrant** includes three academic zones. The Colleges of Agriculture, Human Resources, and Veterinary Medicine are found in **Academic zone 1**, **Academic zone 2**, and **Academic zone 3**, respectively.

Building use categories, as identified on the campus plan, are based on the **primary functional occupancy** of each structure and do not reflect differences between auxiliary, general academic or other building classifications. As a result of Virginia Tech's space deficit, many campus structures include users from more than one of these functional categories. Examples include administrative functions located in converted dormitories and athletic buildings, and academic functions located in dormitories and administration buildings.

Academic. This building category (17) includes teaching, research, and extension functions.

Residential. This building category includes dormitories (18) and special purpose housing which accommodate approximately 110 graduate student residents and 8,400 undergraduate residents.

Service. This building category (19) includes Squires Student Center, University Bookstore, Newman Library, maintenance, administration, dining halls, and the power plant.

Athletic. This building category (20) includes Cassell Coliseum, Rector Field House, Lane Stadium, and the tennis pavilion.

"Civilizations decline, Toynbee said, not so much because of invasions or other external forces but because of an internal hardening of ideas. The 'elite creative minority' that once gave life to the civilization has been gradually replaced by another minority — still dominant, but no longer creative.

Creativity requires constant transformation, experimentation, flexibility. Cynicism, a chronic state of distrust, is antithetical to the openness necessary for a creative society. To the cynic, experiments are futile ... all conclusions are foregone. Cynics know the answers without having penetrated deeply enough to know the questions. Just as we must let go of dead philosophies, illusions and old science to confront the reality, so a country must keep challenging its traditions if it wants to be transformed ... if it wants renewal."

Marilyn Ferguson
Aquarian Conspiracy



Concept

The intent of the Master Plan is not to articulate each opportunity and document each possible solution to a problem, but to raise the awareness of those who design the future campus, to articulate concerns, and to instill an understanding of, and a sympathy for, the critical issues involved.

Issues

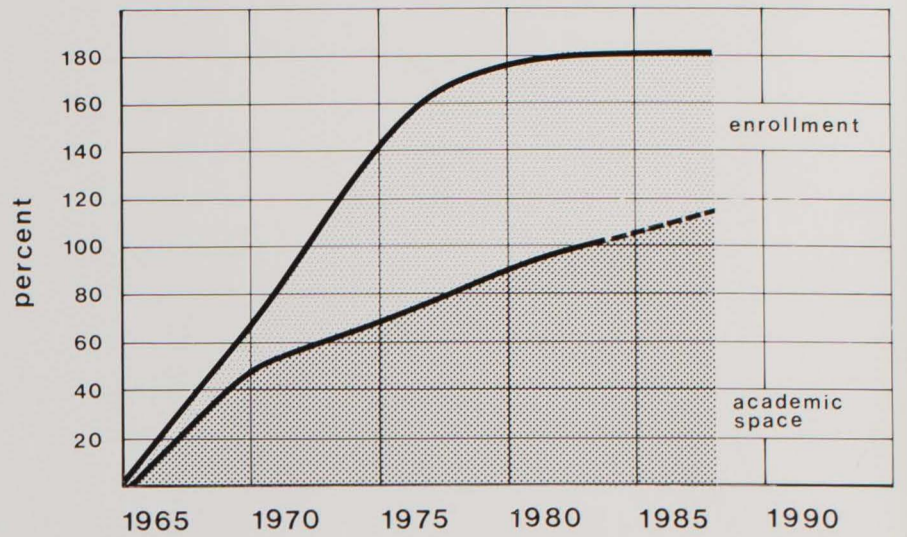

23. Growth in enrollment and academic space

Beginning in 1965, Virginia Tech experienced unprecedented growth in both enrollment and the quality and scope of its educational programs. Sustaining this quality and building upon it, however, require a commitment to provide adequate facilities supporting the University's broad range of learning, research, and service opportunities.

A few germane facts: Enrollment during Virginia Tech's expansion increased some 178 percent — from about 7,500 in the mid-1960s to more than 20,000 in 1980. But growth in academic space (23) was by no means proportional, increasing only 95 percent in the same period (from 576,000 to approximately 1.1 million assignable square feet). By applying guidelines established by the State Council of Higher Education in Virginia, Virginia Tech was calculated to have an academic space deficit (26) of approximately 400,000 assignable square feet in 1982 — a figure representing only the shortage of classroom, laboratory and office space. This 36 percent deficit was based on existing, not projected, enrollment.

But the true implications of a deficit of this magnitude are not statistical. They become clearer when measured in terms of gross spatial dysfunction. Some glaring examples: Overcrowded classrooms (24), inadequate office space (25), corridors used as storage space (27), inappropriately-housed research labs (28), and a complete absence of student and faculty lounge and study space (29).

All these conditions have a negative impact on the basic mission of Virginia Tech. They lower morale and hinder the University's ability to attract and retain students and faculty of the highest caliber. The space deficit also severely limits flexibility to embrace the most current teaching and research methodologies and restricts the University's ability to adjust space allocations and assignments according to its changing needs and priorities.

This Master Plan addresses the space deficit problem with an incremental solution that is comprehensive in scope.

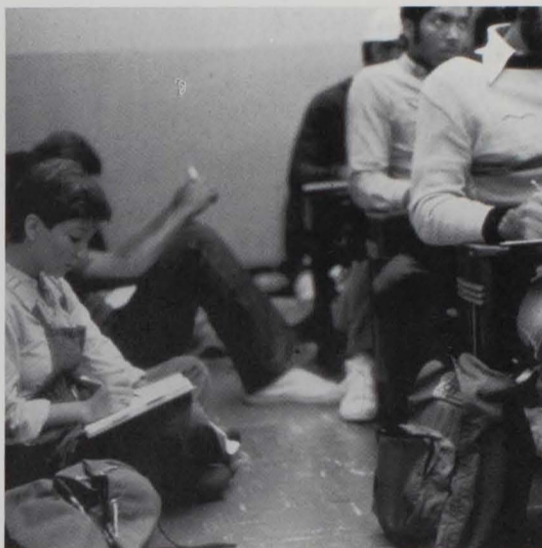

24. Classroom

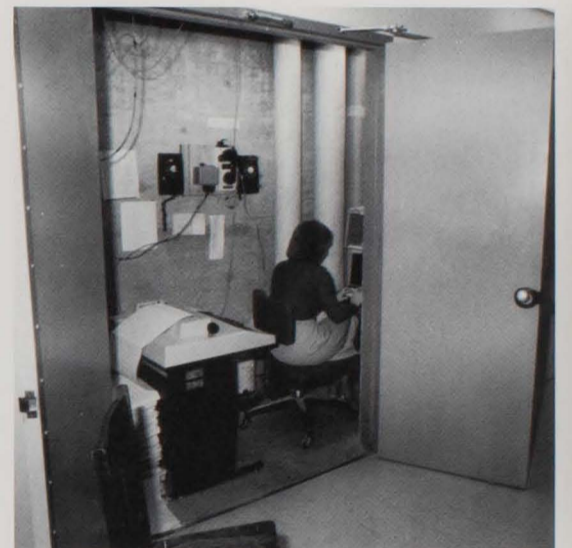

25. Office

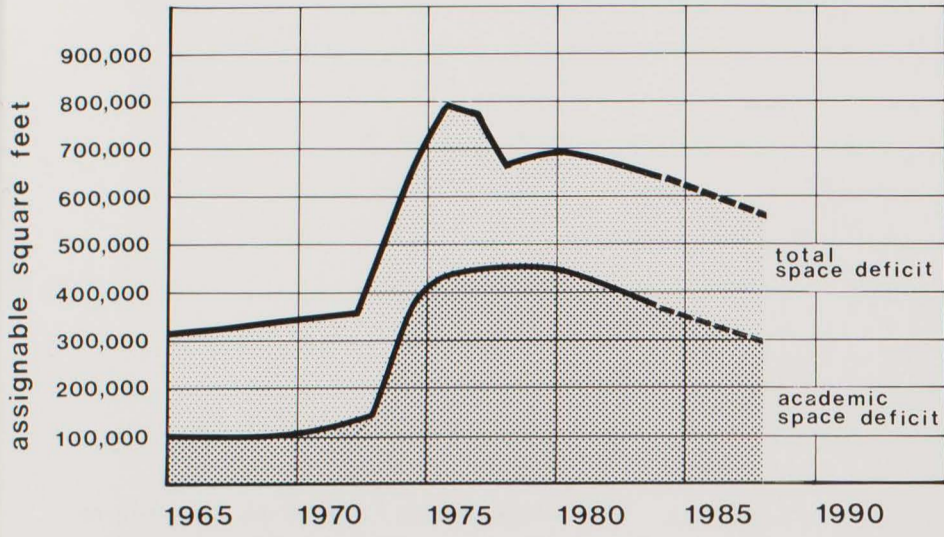

26. Academic and general space deficit



27. Corridor

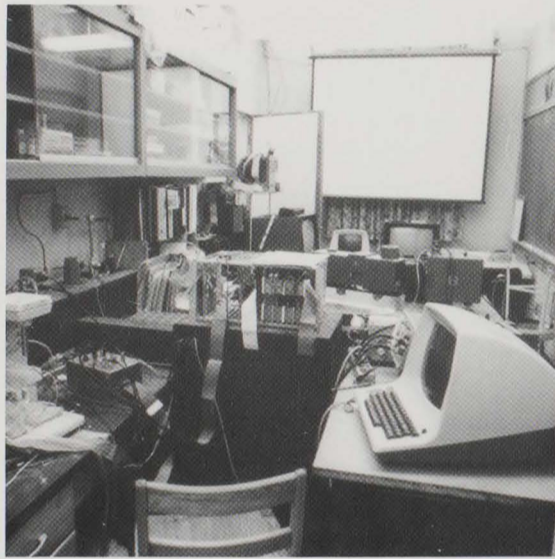

28. Laboratory

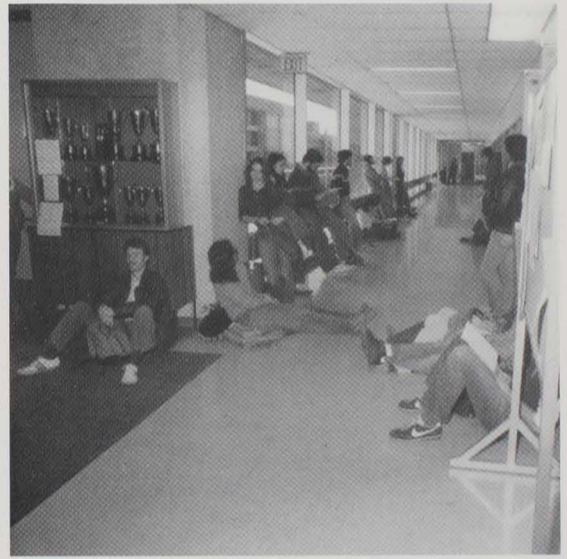

29. Lounge



30. Dysfunction as a result of Virginia Tech's space deficit



31.

Incremental Infill Construction

The concept of incremental infill construction was developed to deal effectively with qualitative and quantitative issues related to the following campus planning objectives:

- To preserve and reinforce the positive aesthetic, historical, and functional characteristics of the campus.
- To alleviate or eliminate safety concerns.
- To eliminate space deficits through regeneration, renovation, and construction.
- To optimize the functional performance of the physical plant.
- To optimize the energy performance of the physical plant.
- To aggregate and capitalize on construction and operational cost-saving opportunities.
- To maximize the impact of limited construction dollars.

The conventional "state of the art" for campus development involves large-scale, occasional construction on an expanding cam-

pus periphery, usually accompanied by a progressive, functional, and physical obsolescence of existing buildings in the campus core (32). But the disadvantages do not stop there.

This approach is inherently land-consumptive. It requires major infrastructure expenditures for roads, walkways, utilities, and landscaping. It increases pedestrian inconvenience. And large, costly building projects become the rule in order to maintain appropriate scale relationships to the existing campus and to justify considerable infrastructure costs, which are relatively independent of building size. This traditional approach also encourages and reinforces separation of functions, which contradicts the trend toward integrating instructional and problem-solving methodologies and promoting an interdisciplinary academic experience.

The infill planning approach, as developed by Virginia Tech, on the other hand recognizes the dynamic program needs of the eight colleges, multiple disciplines, and support functions which its physical plant (32) must accommodate. This approach acknowledges the desirability of an environment that encourages and supports interdisciplinary

involvement. To this end, the University evolved a concept of "university space" (197) which will adapt to the constant modulation of program needs — a concept which opposes past notions of colleges as isolated, self-contained entities within the University.

The primary strategies of incremental infill construction are:

- The **construction** of relatively small building increments strategically located adjacent to present core buildings and connected to them where possible by solar atria to provide contiguous, programmatically-integrated expansion of existing space (33). These new increments will accommodate activities which are inadequately or inappropriately housed in existing buildings. They also provide the sophisticated environments required by advanced teaching methods, instructional research activities, and specialized uses for which existing space is inadequate.
- The **regeneration** of existing core buildings to permit the functions best suited to their internal configurations and sub-

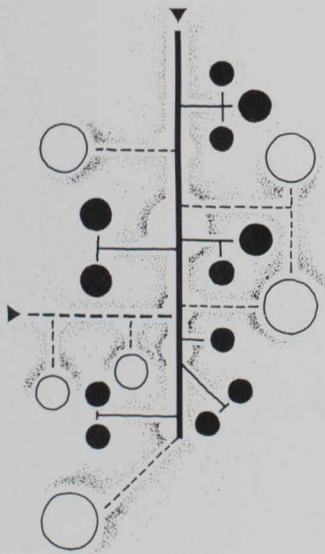

conventional model

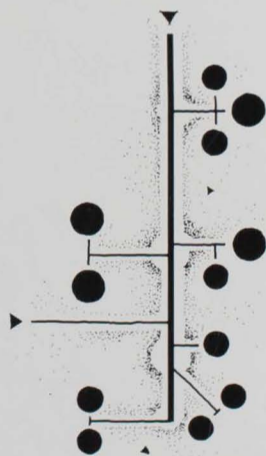

existing organization

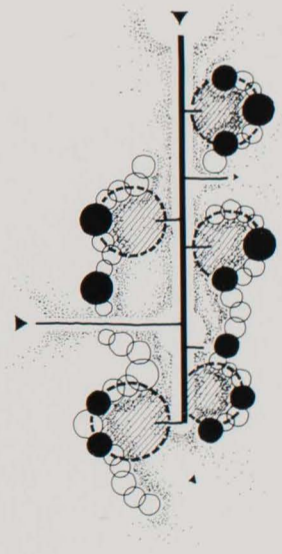

infill model

Consumes land	Conserves land
Requires large building increments	Accommodates small building increments
Limits funding alternatives	Maximizes funding alternatives
Inconveniences pedestrian circulation	Enhances pedestrian circulation
Requires expensive infrastructure expansion	Utilizes existing infrastructure
Independent of existing campus condition	Serves as catalyst for campus regeneration
Encourages additive programming and planning	Requires integrative programming and planning
Limits flexibility by separating space	Provides flexible contiguous space
Isolates functions and activities	Integrates functions and activities
Ignores contextual value of space	Recognizes contextual value of space

32. Planning models

systems. This represents a commitment to correct inadequate and marginally habitable space which resulted from inappropriate conversion, retrofitting, and re-assignment. The Infill Master Plan calls for returning these spaces to their original, environmentally compatible uses (or assigning appropriate new uses) and constructing appropriately-scaled and -serviced space in adjacent increments.

Analysis of this approach shows it to be functionally advantageous, environmentally beneficial, and fiscally responsible. Specifically, incremental infill construction related to existing core buildings results in contiguous space which:

- Greatly increases flexibility in making space assignments.
- Increases ability to accommodate expansion and contraction in programs and activities.
- Provides an improved environment for interaction between disciplines.
- Provides a potential "bonus" solar atrium space (34) that links core buildings with incremental new construction. This solar atrium will, in turn:
 - Expand interior circulation space, which encourages informal faculty-student interaction, provides study spaces, and allows for a variety of unprogrammed activities.
 - Create first-cost savings in the enclosure and mechanical systems of the new construction.
 - Generate annual cost savings for both the new increments and impacted existing buildings by using passive and energy conservation concepts.

While this strategy offers a dynamic and exciting alternative for campus expansion and regeneration, it is not without risk. Its implementation requires particularly close attention to the visual and physical impact of construction within the campus core, in order to ensure its spatial and aesthetic integrity.

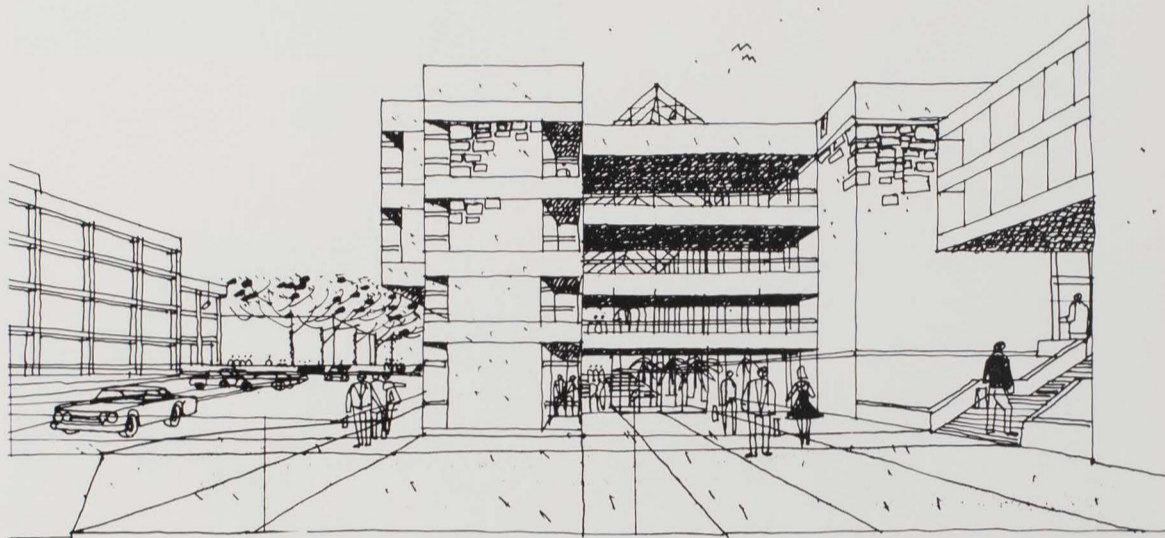

33. Atrium link

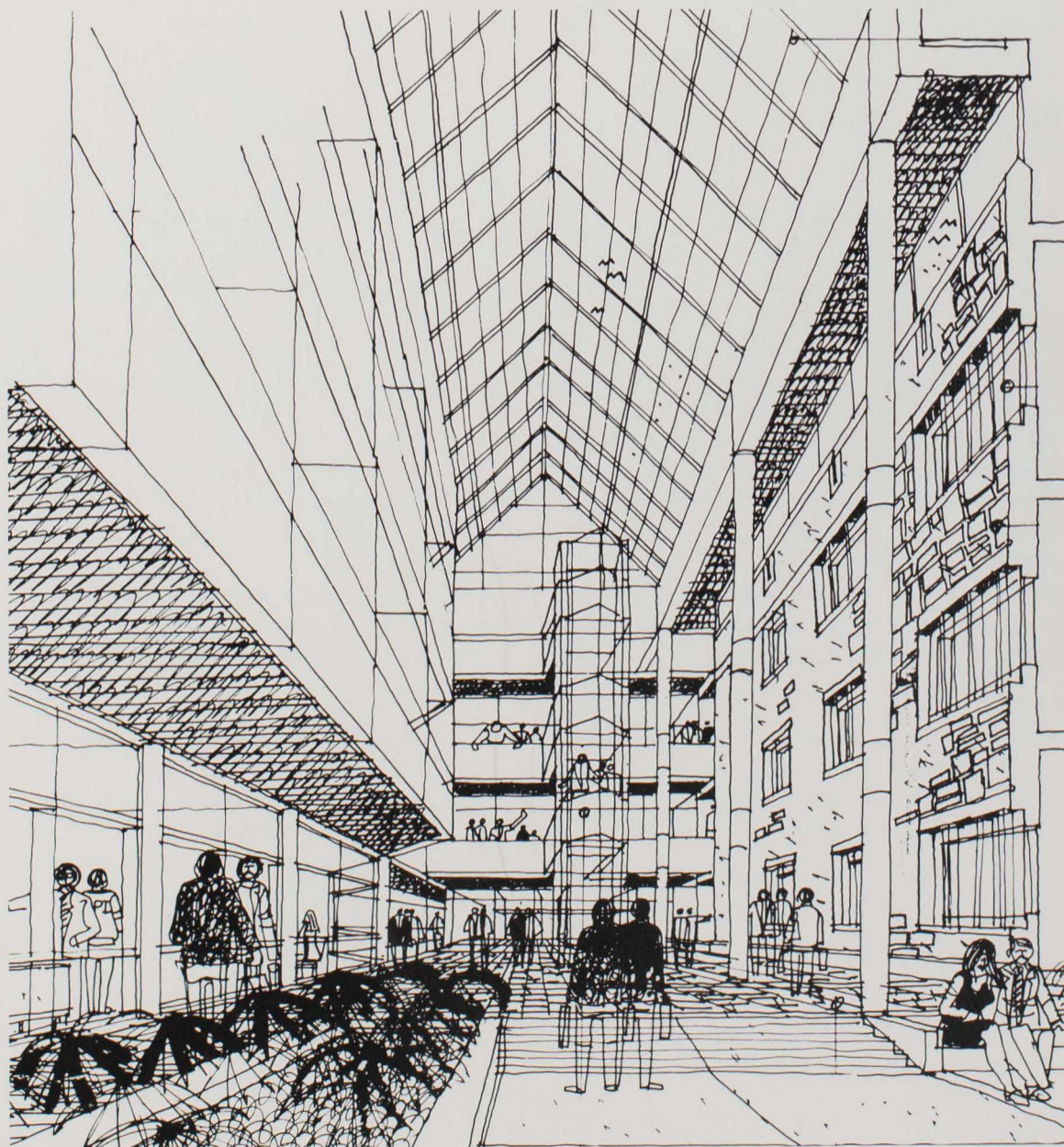

34. Atrium

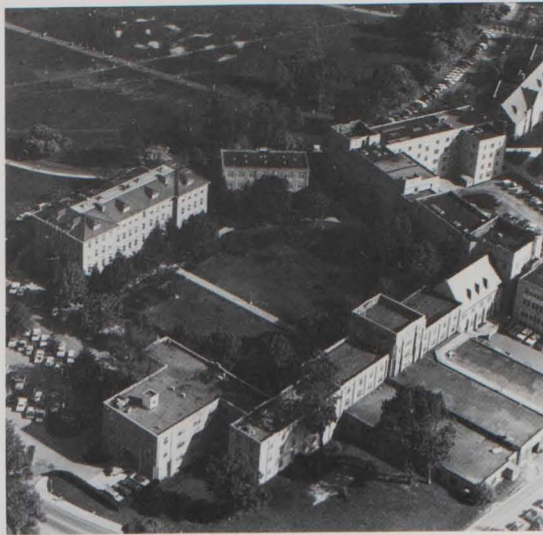

35. Agricultural quadrangle



36. Conceptual development

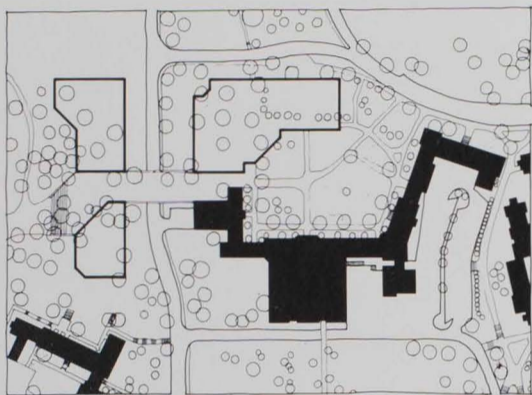

37. 1972 Master Plan proposal

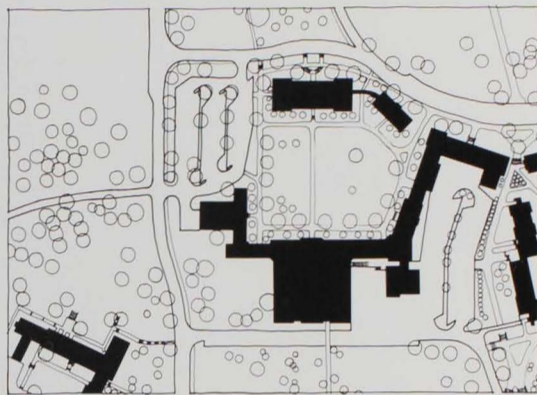

38. Existing agricultural quadrangle



39. 1983 Master Plan proposal

Incremental Infill Construction Prototype

The Agriculture Quad is one of the most clearly defined, richly landscaped, and delightfully scaled academic quadrangles on campus (35 and 38). There are, however, several functional constraints associated with the quad buildings, which were not designed to accommodate the environmentally demanding research and teaching activities they presently house. Added accessibility and safety problems occur because of the age of these structures. The 1972 Master Plan called for demolition of two Ag Quad buildings facing the Drill Field and the construction of three large-scale structures linked by a pedestrian bridge across Greenhouse Road (37).

This Master Plan calls instead for the construction of eight smaller-scaled infill increments linked to the existing quad buildings, none of which will be demolished (36 and 39). Some advantages of this approach are to:

- Integrate new, environmentally-demanding research and teaching spaces with existing functions.
- Facilitate the regeneration of all existing space.
- Provide handicapped access and improved vertical circulation to existing structures through linkages with new increments.
- Improve the energy performance of existing structures.

- Reduce the need for expensive infrastructure extensions.
- Generate functionally advantageous contiguous space.
- Provide funding and construction options to respond to program priorities and resource availability.
- Provide several atria spaces, which include inherent amenities.
- Preserve the Drill Field aesthetic.
- Reinforce the quadrangle definition and integrity.
- Maintain and enhance the existing buildings' scale and aesthetic.
- Preserve the heavily-wooded area to the west of Greenhouse Road.

The size and disposition of increments of construction in the Master Plan represent a response to both the generic planning goals articulated in this document and the total campus space deficit. While they are site-specific, the plan footprint and mass are not program-specific. This Master Plan anticipates changes as specific needs are identified and increments are realized.

Increment Capacity (gross square feet)

1.	27,000	34.	18,000
2.	8,000	35.	65,000
3.	14,000	36.	5,000
4.	7,000	37.	10,000
5.	8,000	38.	67,000
6.	39,000	39.	46,000
7.	15,000	40.	20,000
8.	16,000	41.	25,000
9.	94,000	42.	18,000
10.	17,000	43.	9,000
11.	15,000	44.	8,000
12.	15,000	45.	20,000
13.	18,000	46.	8,000
14.	18,000	47.	12,000
15.	19,000	48.	29,000
16.	37,000	49.	64,000
17.	14,000	50.	23,000
18.	8,000	51.	30,000
19.	28,000	52.	72,000
20.	27,000	53.	19,000
21.	161,000	54.	19,000
22.	20,000	55.	15,000
23.	24,000	56.	16,000
24.	25,000	57.	39,000
25.	21,000	58.	4,000
26.	21,000	59.	10,000
27.	48,000	60.	11,000
28.	20,000	61.	14,000
29.	36,000	62.	9,000
30.	10,000	63.	20,000
31.	41,000	64.	21,000
32.	9,000	65.	15,000
33.	46,000		
			1,687,000





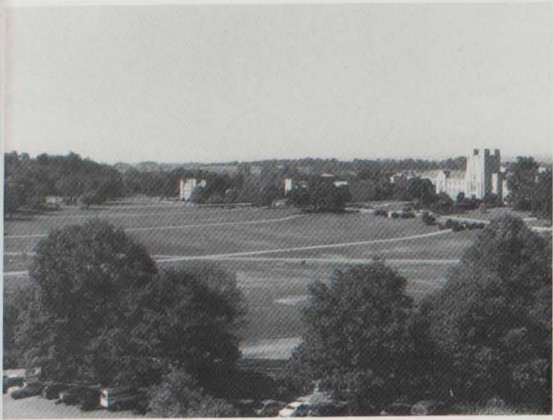

40. Drill Field



41. View to Drill Field

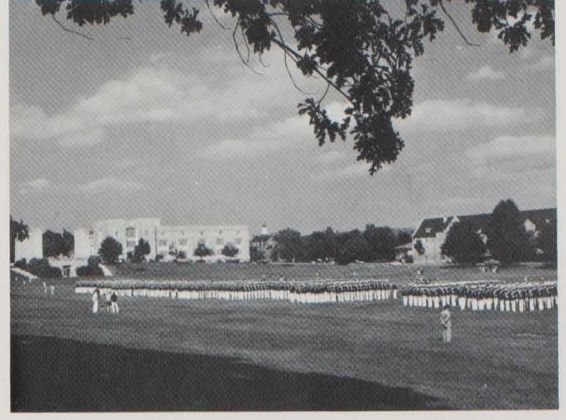

42. Drill Field

Perceptual Analysis

A perceptual analysis was one of the first studies undertaken to ensure that Virginia Tech's campus not be compromised by construction of more than a million square feet of space within its core. The objective of this study was to identify and evaluate those special organizational, spatial, and environmental characteristics critical to the identity of the University.

Next to the rural character of the campus environment, its most significant physical quality is an impressive aesthetic and spatial

cohesiveness (43). This strong and easily perceived campus organization is a result of the visual interconnection of discrete, well-defined spaces. The bowl-shaped topography, the lowest point of which is the center of campus, reinforces this organization.

Especially critical to the unique character of Virginia Tech's campus are three clearly defined, interfunctional spaces. Most important of them is the Drill Field (40), which anchors the campus core and affords views to most of the University grounds. Key to this experience is the juxtaposition of surrounding buildings, which frame the views of quads and buildings beyond them (56). For people

in these peripheral spaces, glimpses of the Drill Field provide a reference to the heart of campus (41).

In addition to the spatial importance of the Drill Field, its functional contribution is essential. Though it only occasionally serves as parade ground (42), a use which diminished with Virginia Tech's evolution from military school to comprehensive university, the Drill Field maintains a central role in University life. Spontaneous recreational activities, intramural sports, and heavy pedestrian use lend a vitality to this space. It also provides a transition between the academic and residential zones of campus.



43.

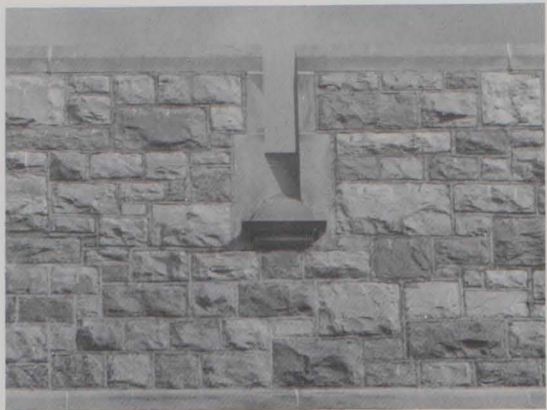

44.

Second of the primary open spaces is the Duck Pond area, which contributes strongly to the visual experience of approaching campus along Southgate Drive. Rich in natural amenities, the Duck Pond environment differs significantly from the Drill Field, though it is only a few yards away. It offers a calm and pastoral setting, a break from the activity and dynamism of the nearby campus core.

Frame structures near the Duck Pond enhance its residential scale (52). Gravel paths meander through dense plantings beside the two ponds, where ducks and Canadian geese live year-round. Picnickers, bicyclists, and



45.

strollers frequent the area of specimen trees and shrubs, while others fish or ice-skate on the ponds.

The third major open space is Pritchard Prairie (53), so named because of its proximity to Pritchard Hall. The area is treeless and somewhat uninviting in its current state, but its clearly defined edges and sense of place have potential to contribute to the rich experiential qualities of campus.

Virginia Tech's academic and residential quadrangles (54) are next in consideration. The quads, which are clearly defined by their surrounding structures, contribute significant-



46.

ly to the campus fabric. Too large to be called intimate, they nonetheless provide a delightful contrast to the three primary spaces and serve as transitions from the larger university context to individual classroom buildings and dormitories.

These structures boast a variety of architectural styles: Neo-Georgian, Collegiate Gothic, and Contemporary, with a materials palette of native stone, brick, limestone, concrete, and glass. Collegiate Gothic (57) is the dominant form, particularly in the core campus buildings circling the Drill Field and the dormitories to the south (55). A contemporary architectural edge formed to the northwest as program expansion required new academic structures (48).

The quadrangle as an integral component of the campus was severely compromised — in fact, abandoned — in campus construction projects from 1965 to 1980. This lapse in commitment to the relationships between people and the historical context and spatial qualities of their environment — and the corresponding introduction of an institutional scale of building and space (47) — fortunately has been reversed with the implementation of this plan.



47. Cowgill and Derring Halls



48. Contemporary architectural edge

Derring

Cowgill

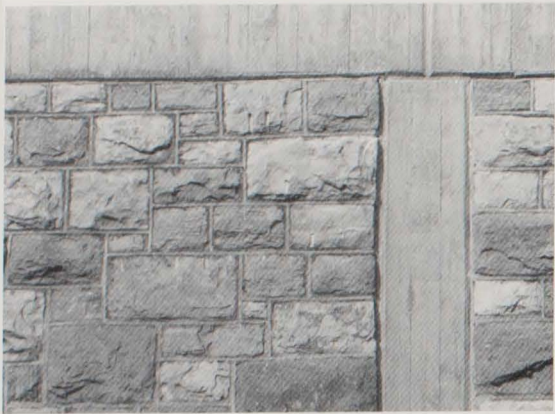

49. Frame and stone

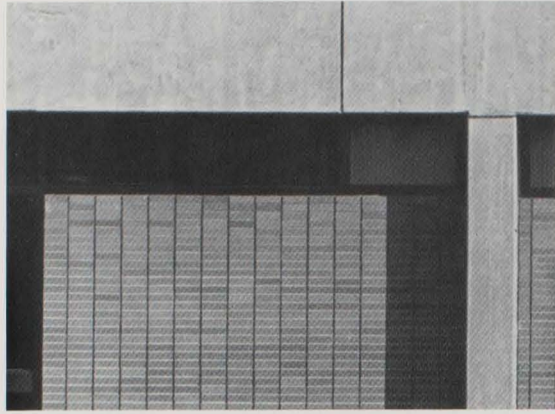

50. Frame and brick

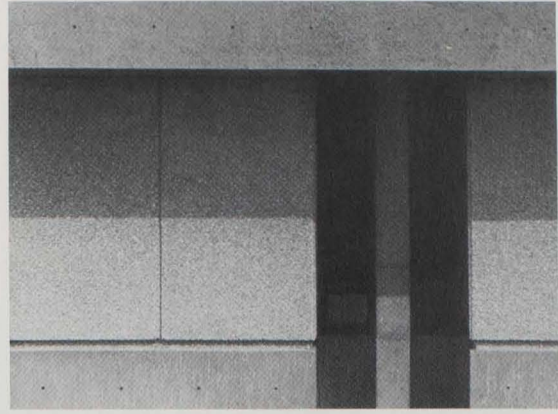

51. Frame and precast



52. Solitude, Duck Pond area

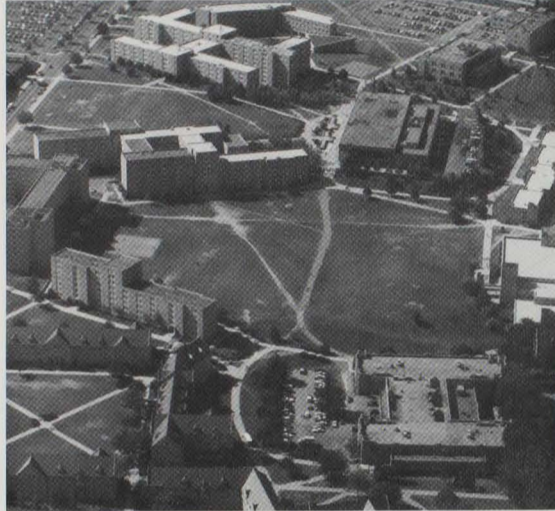

53. Pritchard Prairie

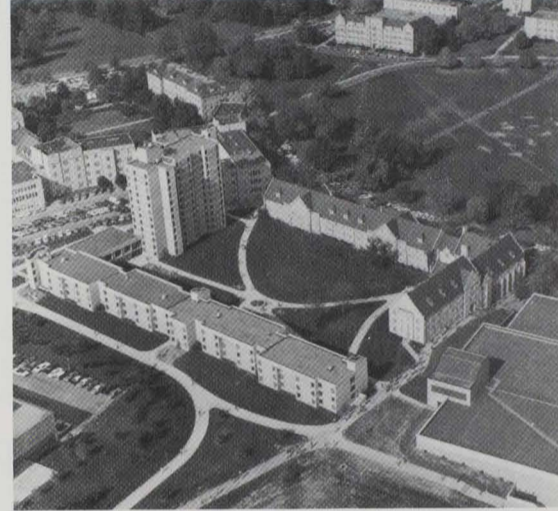

54. Campbell Quadrangle



55. Campbell Dormitory

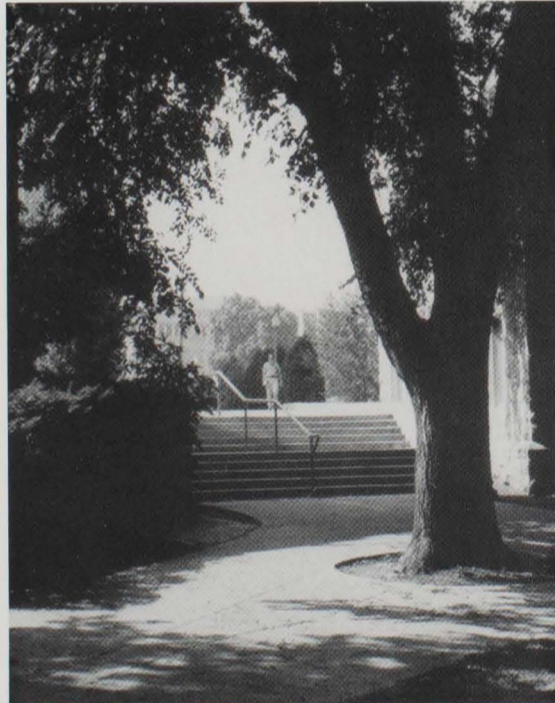

56. View to quadrangle beyond

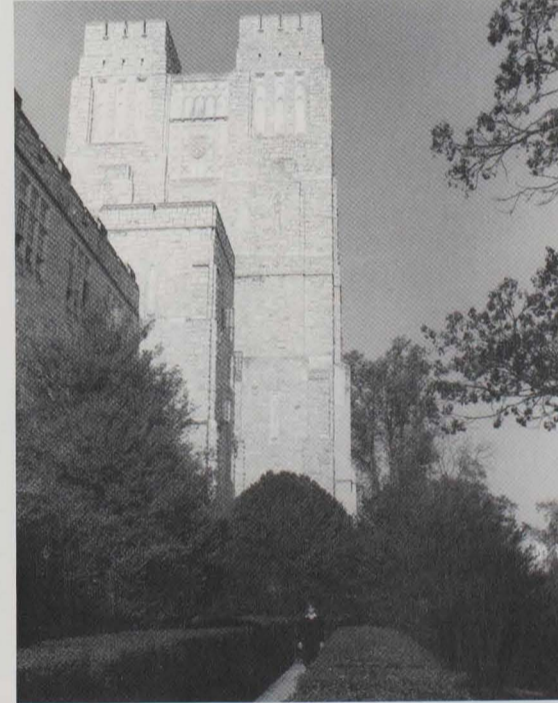

57. Burruss Hall

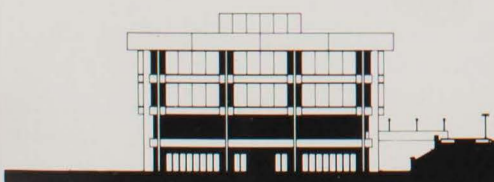

Cowgill



Burruss



Open Space Analysis

The goal of the Master Plan is to realize a future campus where all parts reinforce its environmental quality. To this end, campus open space was evaluated according to its positive, negative, or neutral contribution to the aesthetic and functional integrity of campus.

This classification of open space was based on the quality and appropriateness of plant materials, topographic features, scale, use, visual clarity, and general condition relative to need and expectation.

The implementation of the Master Plan assumes the preservation of positive space and upgrading of negative space. Where possible, within the context of the multiple criteria involved, increments of construction are sited in negative areas and serve as the catalyst for their upgrading.

A graduate dormitory initiated prior to the new Master Plan was redesigned and resited to be consistent with this new philosophy. Objectives for the graduate housing project were:

- Preserving the heavily-wooded original site.
- Providing the catalyst for upgrading the area southwest of Hillcrest Hall.
- Creating a graduate quadrangle.
- Functionally integrating with Hillcrest Hall, also a graduate dorm.
- Enhancing the views of campus as one enters from U.S. 460 By-pass along Southgate Drive.
- Creating dramatic views into the wooded area from the new dorm.
- Eliminating, through road and access modifications, serious pedestrian vehicular conflicts between Wallace and Hillcrest Halls (69).
- Taking advantage of passive solar opportunities.

Future projects will be developed to meet similar goals, treating campus-wide design issues with the same attention and sensitivity used in designing individual building increments.



58. Original proposed site



59. Wooded area at Hillcrest Hall

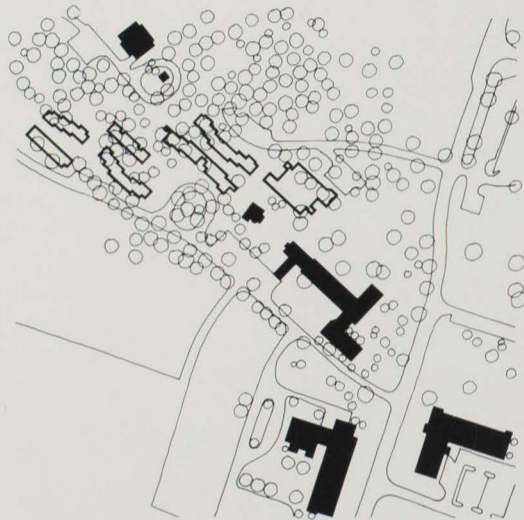

60. Graduate Dormitory, original plan

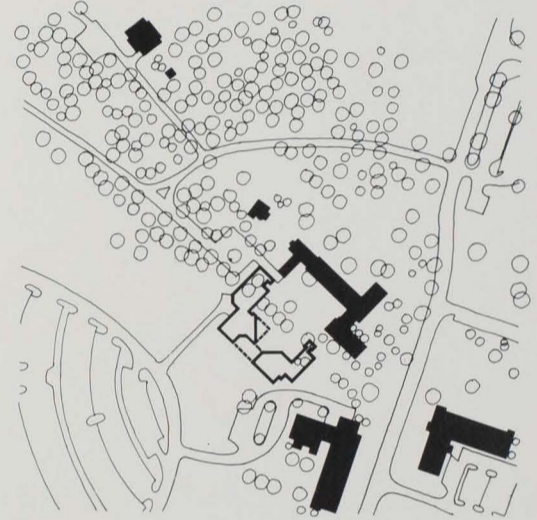

61. Graduate Dormitory, revised plan



62. Negative area south of Hillcrest Hall



63. Upgraded area south of Hillcrest Hall

Planning Concepts

The goal of this Master Plan is to provide a campus environment of perceptual and architectural integrity; a campus rich in visual experiences supportive of its history and future; a campus reflective of, and compatible with, its macro-environment; and a campus which reinforces, in terms of space, mass and function, the basic mission of the University ... to educate.

To provide a perceptual framework that will facilitate the realization of this goal, as well as the range of generic planning goals articulated throughout this document, three key strategies have been advanced:

- To create specific conditions of arrival and entry to campus that conform to issues of what is seen, and when and how it is seen.
- To provide a condition of campus edge that ensures the visual integrity of the University and its relationship with the surrounding community.
- To develop the many components of the campus as an **integrated, experiential whole** consisting of open space, physical elements and functional systems.

Entry: While there are several major and minor vehicular entryways to Virginia Tech, four are distinct and of particular importance to how one experiences arrival to campus. The first of these is the western entry from the U.S. 460 By-pass, an entry offering a transition from the rural surround to the more structured environment of the core campus (64). This route follows Southgate Drive past the College of Veterinary Medicine, then turns north and parallels the Duck Pond, ending at Greenhouse Road. This route has been developed as a **symbolic** entry to campus which introduces the user to a sequence of University experiences — its function, spatial character, and architecture. Reinforcement of this experience was a criterion used in siting and designing the College of Veterinary Medicine, Graduate Dormitory, and other campus structures. Trees and shrubs are used to enrich the visual dynamic by framing vistas and developing a progression of openness, enclosure, and canopy (65).

Second of these, the Mall (66), is a **formal** entry, a broad boulevard connecting downtown Blacksburg to the Drill Field. While the

physical roadway is unchanged in the Master Plan, extensive landscape modifications will reinforce the historical significance of this area and soften the negative views seen when approaching Main Street and its commercial structures from the Drill Field. Arranging new trees informally at the Main Street end will create a park-like border with the town, reminiscent of the arboretum which existed before the Mall's construction (67).

The third and fourth distinct entries are along Price's Fork Road at Greenhouse and Tom's Creek Roads (68). Because of topography, these **functional** entries provide a

dramatic overview of the campus, with the academic zone in the foreground and the residential zone and athletic buildings behind. These entries accommodate the largest volume of vehicular traffic. Because of its proximity to nearby hotels and commercial facilities, the area adjacent to the Price's Fork/Greenhouse Road entry is proposed as the site for a new Continuing Education Center. This center, which is the meeting place for the University community and its extended constituency, would function as a particularly appropriate front door to campus while significantly reducing the negative impact of being greeted by a 2,200-car parking lot.



64. U.S. 460 By-Pass/Southgate entry

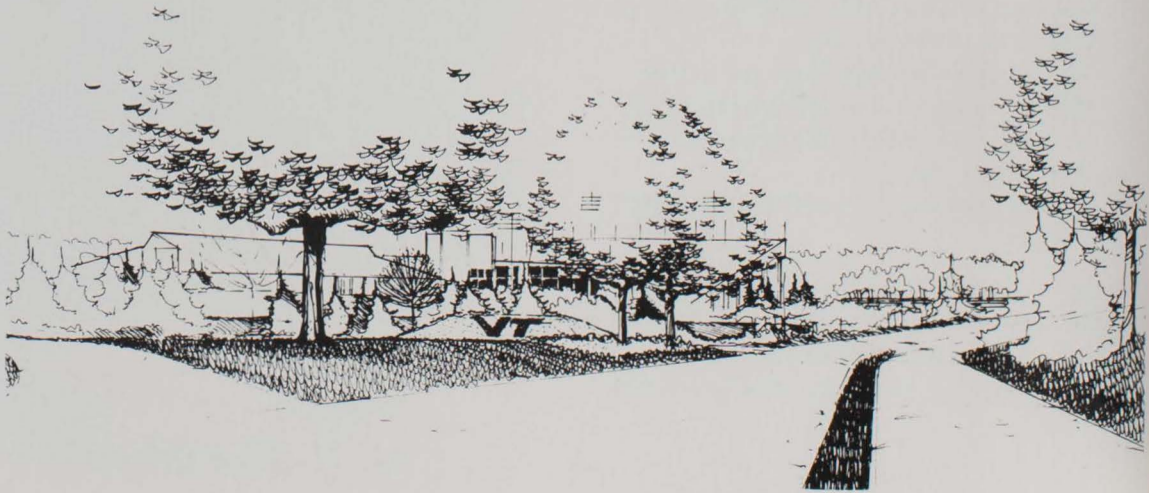

65. Development of Southgate as symbolic entry



66. Mall entry - formal

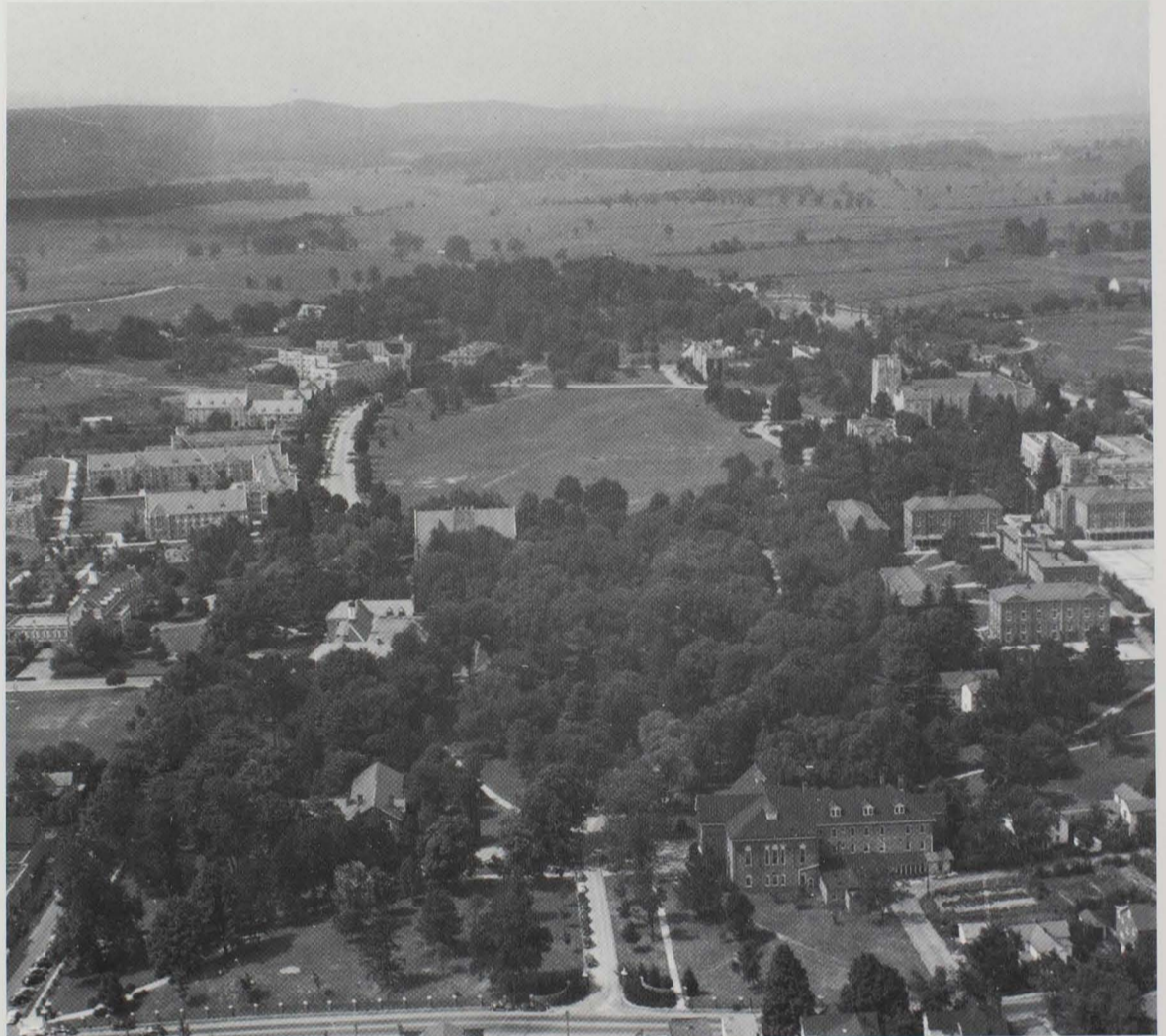

67. Original Mall site



68. Tom's Creek Road and Greenhouse Road entries - functional

Edge: The Master Plan denotes three conditions of the campus edge requiring distinctly different levels of planning response.

- **Modification.** On the northern perimeter, plant material is used extensively along Price's Fork Road to provide a transition from the surrounding community to the campus. Dense planting of shrubbery related to an accentuated topographical buffer softens the negative visual impact of large parking lots on the residential area bordering them.
- **Refinement.** The existing seam between the eastern edge of campus and the community evolved over many years, and the scale and functional relationships there are appropriate. Only detail changes are proposed here, with the intent of clarification, enhancement, and reinforcement. These changes relate primarily to circulation links between the student services quadrant of campus and Blacksburg's downtown commercial center.
- **Preservation.** In both function and scale, the interface of campus with the adjacent rural environment to the west and south is excellent. It needs only to be protected.

Integrated components: Key to this strategy is the discreet placement of new increments of construction within the core campus, resulting in the creation of **architectural edge** and **massing composition** (70) the purpose of which is the clarification and enhancement of major open space, the definition of primary functional zones, and the preservation, reinforcement, and replication of interior quadrangles. The designation of structures as low-, mid-, and high-rise is based on similar concerns developed through a study of the campus in section. This designation is intended to create a sculptural, three-dimensional composition (69) which reinforces the functional and site-specific criteria associated with increments. Walkways, plazas, landmarks, and landscape elements, while influenced by functional requirements, also combine to form an environmental tapestry of rich perceptual experiences.



69. Proposed graduate dormitory

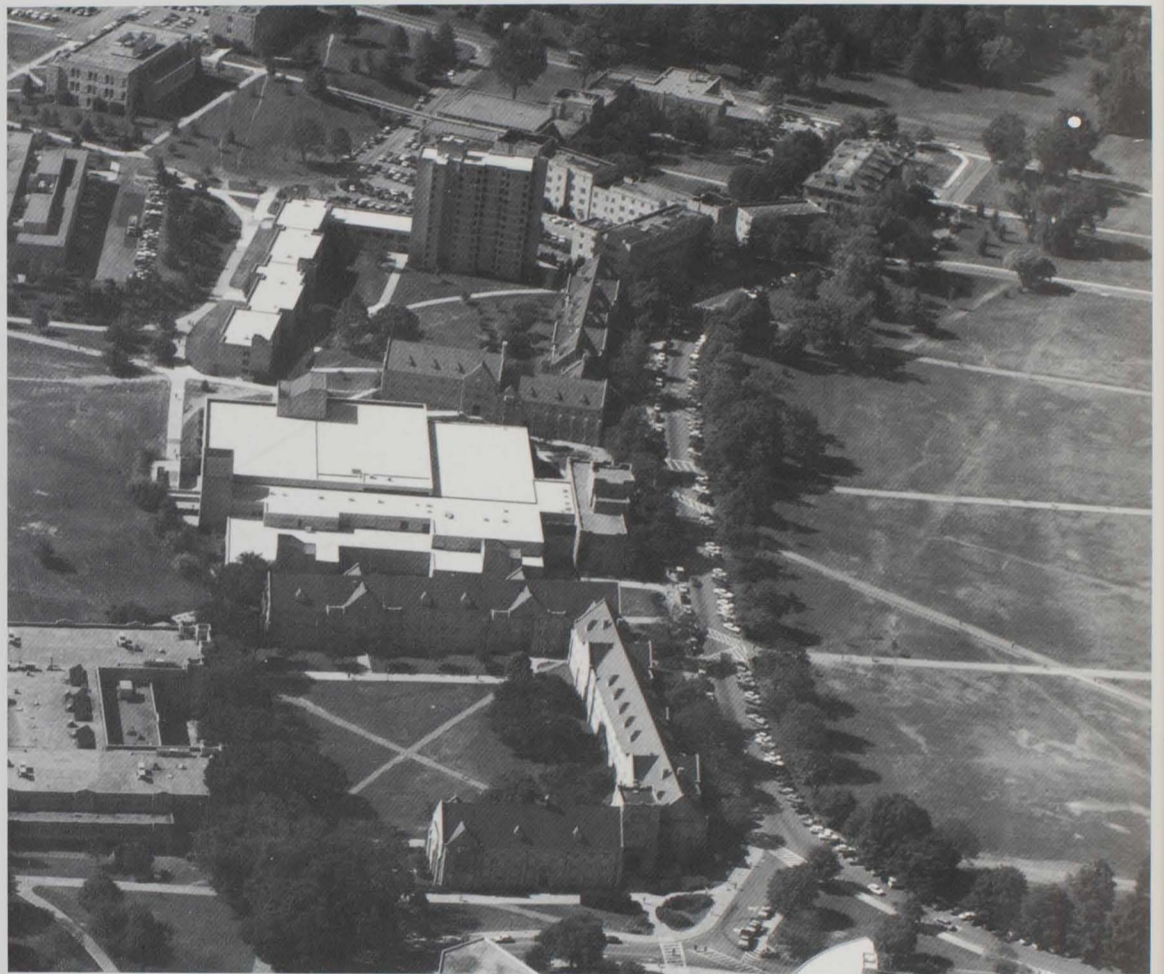

70. Mass and architectural edge to clarify and define



71. Edge penetration



○ dup
▲ landmark
┌───┐ architectural edge

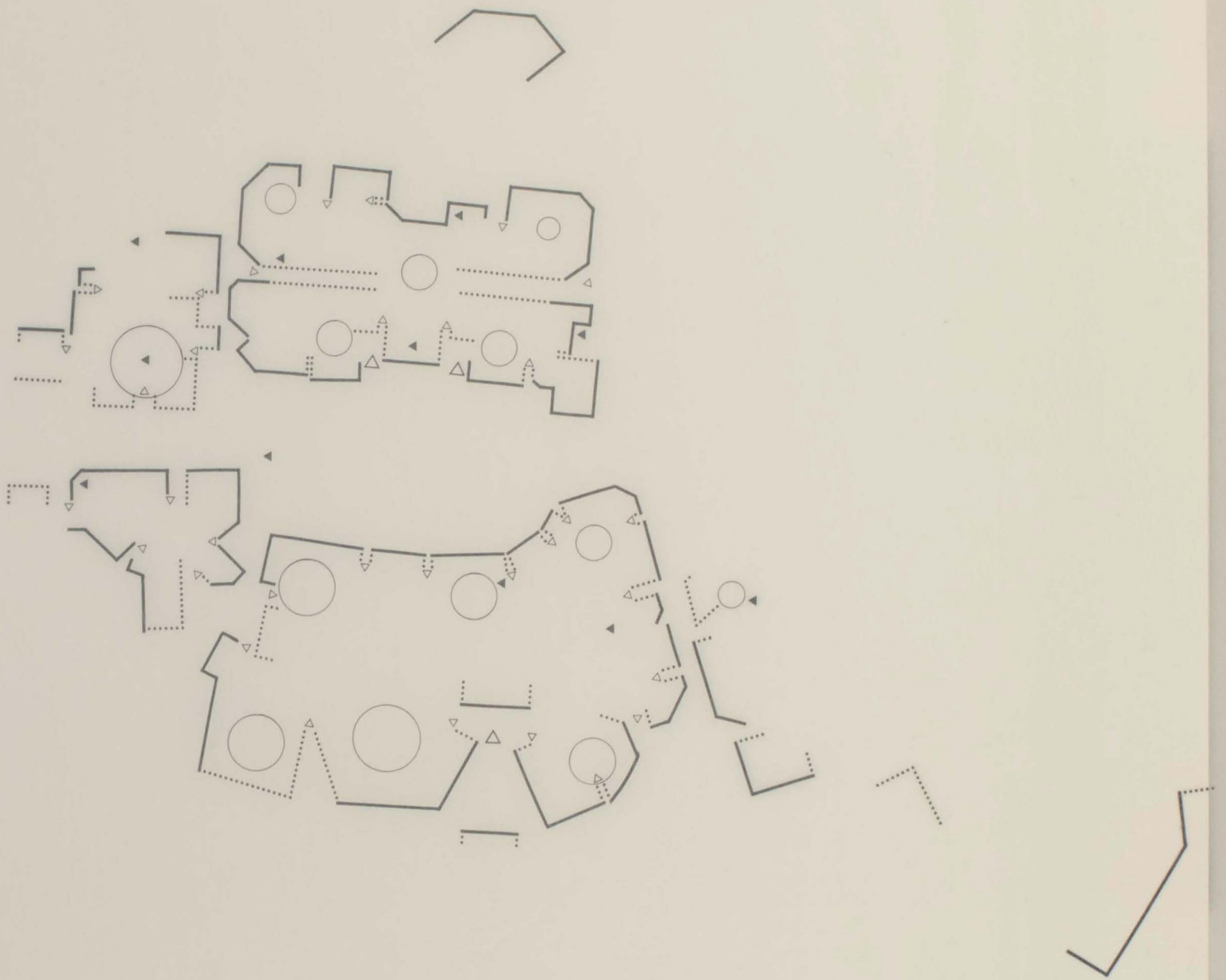

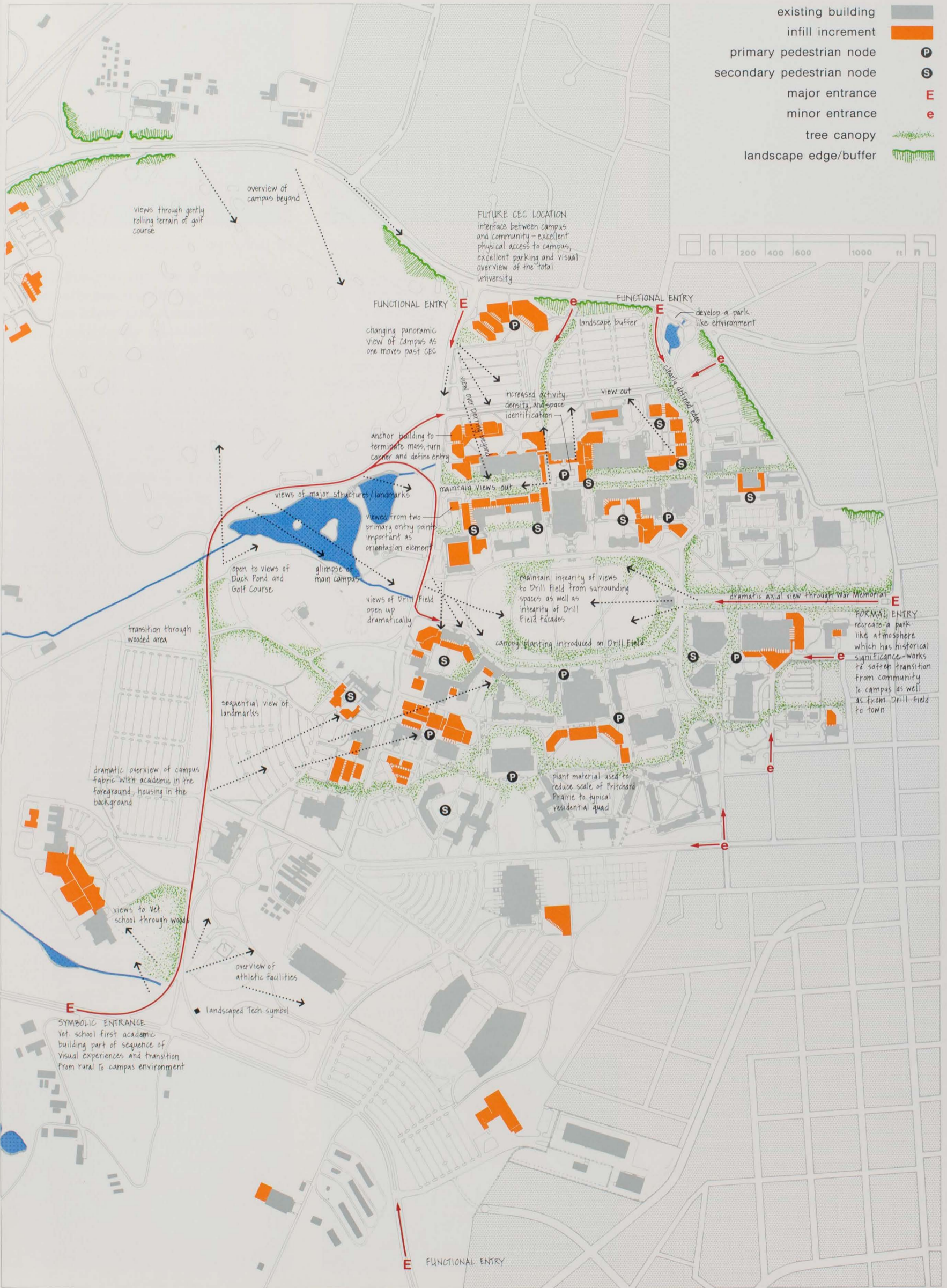

- existing building
- infill increment
- primary pedestrian node P
- secondary pedestrian node S
- major entrance E
- minor entrance e
- tree canopy
- landscape edge/buffer

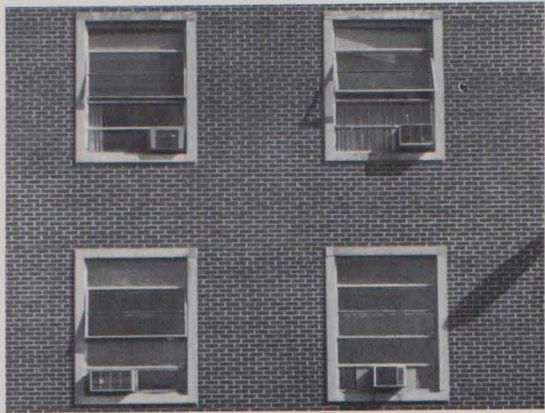

72. Dysfunction - inefficient systems



73. Dysfunction - inadequate sun control

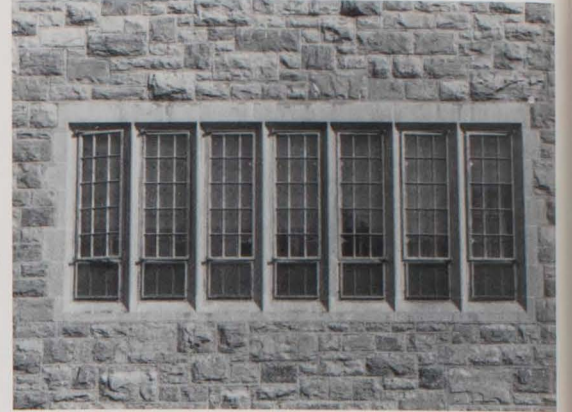

74. Dysfunction - excessive infiltration

Energy Concepts

The goal of this Master Plan is to ensure an energy-efficient campus environment. Realization of this goal is based upon the application of principles of energy-conscious design. It also requires a comprehensive exploration, identification, and implementation of the full range of energy opportunities which exist with each new increment of construction, as well as with each renovation and regeneration project.

Two implementation strategies are involved. First is to evaluate the existing campus for dysfunction and inefficiency (72, 73 and 74) and identify prioritized plans for their elimination, based on cost benefits and resource availability. This approach requires an aggressive program of energy auditing, monitoring, and management.

The second strategy is to ensure that each new increment of construction not only takes advantage of the full spectrum of energy-conscious design principles, but is developed to maximize the positive impact on the existing physical plant's energy system and performance. This, of course, must be accomplished in a cost-effective way which is integral to, and supportive of, the many other functional and planning objectives of the Master Plan.

This Master Plan recognizes that the basic design objectives that follow must be realized in the context of an integrative process which includes consideration of functional requirements, site constraints, infrastructure opportunities, resource availability, massing concerns, and aesthetic criteria. Also reflected in Virginia Tech's energy strategy is the obvious, but often overlooked, fact that the most effective strategy for lowering energy demand and consumption is the elimination or reduction of the need itself. Within that context, the following energy-conscious design objectives are presented in order of their cost-effectiveness.

Objective One: Minimize net square footage. This objective is achieved by accurately "fitting" space needs to program requirements. Realizing a reduction in the net square footage required to accommodate a given activity requires two primary actions

by the designer or planner. First, and most frequently overlooked or avoided, is to question the processes and procedures associated with the activity itself. Modifying the "business as usual" attitudes of the activity participants can substantially reduce the amount of space that needs to be constructed (82).

Second, it is important to differentiate between perceived and true need. Frequently, users articulate needs in terms of their experience with existing space. For example, dysfunctional space, inefficient space, poor circulation patterns, inadequate windows, insufficient ventilation, and substandard lighting all tend to be translated into a need for more, not better, space.

Objective Two: Minimize gross square footage. Improving building efficiency, which reduces the amount of area and volume requiring energy input, is one of the most effective actions that can be taken. Take, for example, a programmatic need for 15,000 square feet. At 50 percent building efficiency,

a 30,000 square foot structure would be required. At 75 percent building efficiency, the same structure could be reduced to 20,000 square feet (75).

Objective Three: Minimize exterior surface area. Integral to the reduction in total floor area is a reduction of exterior surface area required to enclose it. For example, the 20,000-gross-square-foot structure in the previous example would require 26,000 square feet of exterior surface area, if it were accommodated in a 10-foot high, one-story enclosure with four equal sides. But a 20-foot high, two-story enclosure with four equal sides demands only 18,000 square feet of exterior surface. In addition to the number of floors, the complexity and proportions of the plan footprint (perimeter footage) can significantly affect the surface area. Surface efficiency, the ratio of the exterior surface area to the gross floor area, measures the success of this objective (76 and 77). In the examples above, the one-story structure has a surface efficiency of 76 percent and the two-story structure has 110 percent efficiency.

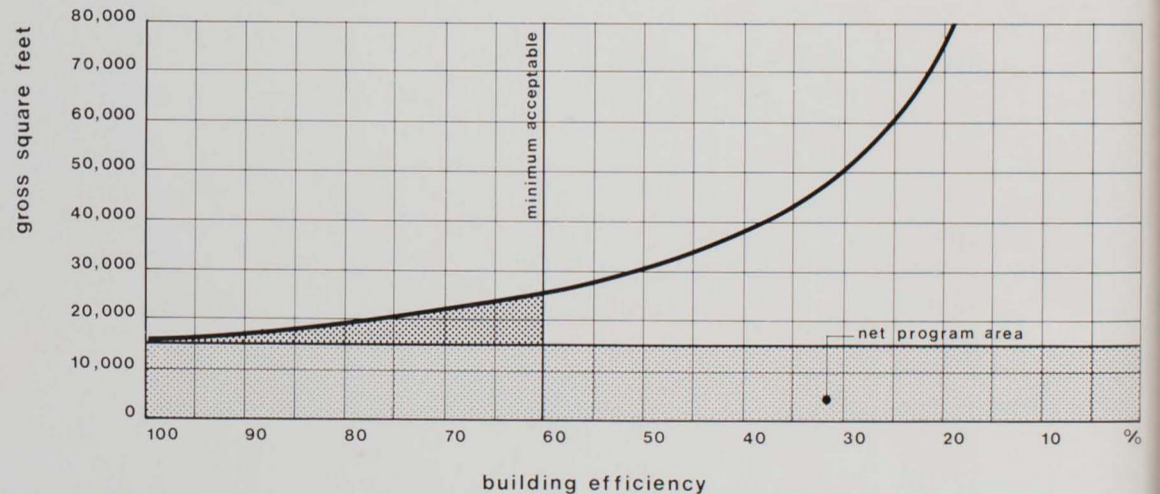

75. Area required to support 15,000 nsf



76. Davidson Hall - 99.8 percent surface efficiency



77. McBryde Hall - 143 percent surface efficiency



78. Solar responsive enclosure

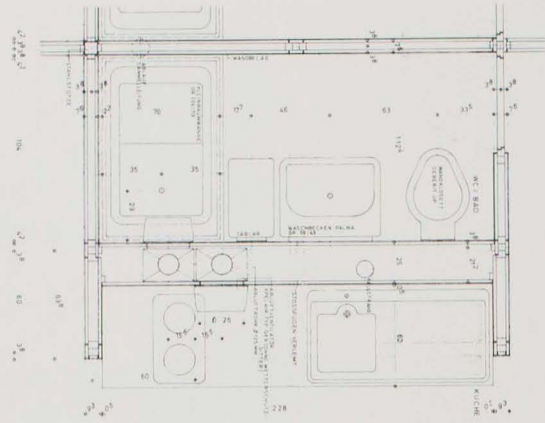

79. Sub-system integration

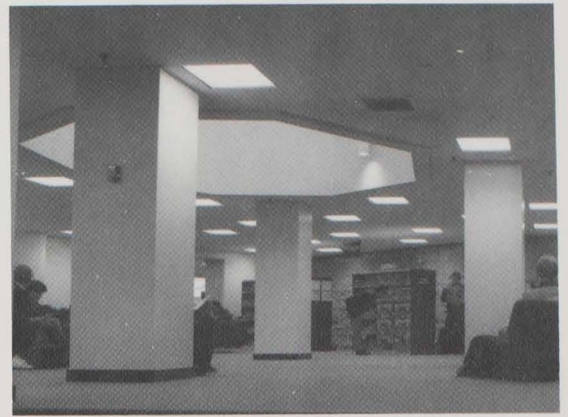

80. Interior daylighting

Objective Four: Optimize the relationship to the environment. Reducing the exposure to northwesterly winter winds and western sun while maximizing exposure to advantageous summer breezes and controlled southern and eastern sun can effect significant energy savings. This is achieved, first, by locating the structure to take advantage of existing land forms, plant materials and existing buildings (81). Second, it is achieved by orienting and shaping the building to maximize southern and southeastern exposure and minimize northern and northwestern exposure (82 and 83). And, third, it is achieved by providing a conceptually compatible enclosure system which accepts the greatest energy benefactors and denies the energy detractors (78). It is important to consider the roof system as part of the enclosure system, particularly in terms of the opportunity to reduce energy costs for lighting by using skylights (80). To meet this objective, maximize summer breezes and winter sun; minimize winter breezes and summer sun.

Objective Five: Optimize the performance of buildings' composite sub-systems. The key aspects of optimizing energy use in sub-systems are compatibility and integration (79). This Master Plan promotes the concept of measuring composite energy performance of a total building according to its owning and operating costs. This concept accepts that optimization of individual systems, in terms of U-values, foot-candles, air changes, infiltration, conduction, horsepower, wattage, cfms, Btus, and so forth is of secondary importance. More critical is the selection and integration of these systems in terms of an energy profile for the total building, a profile which conceptually resolves the constraints and opportunities of both the exterior and interior environment. In addition to reducing energy consumption and increasing performance, realization of these objectives will almost always result in substantial construction cost savings.

As in other areas of the Master Plan, an attempt has been made to convert liabilities to assets. One example is the lack of insulation in Tech's buildings built prior to 1980, combined with a dominant exterior wall assembly of eight to 12 inches of native stone with masonry block backup. When these wall assemblies are seen as potential heat sinks and, in effect, very large radiators, they

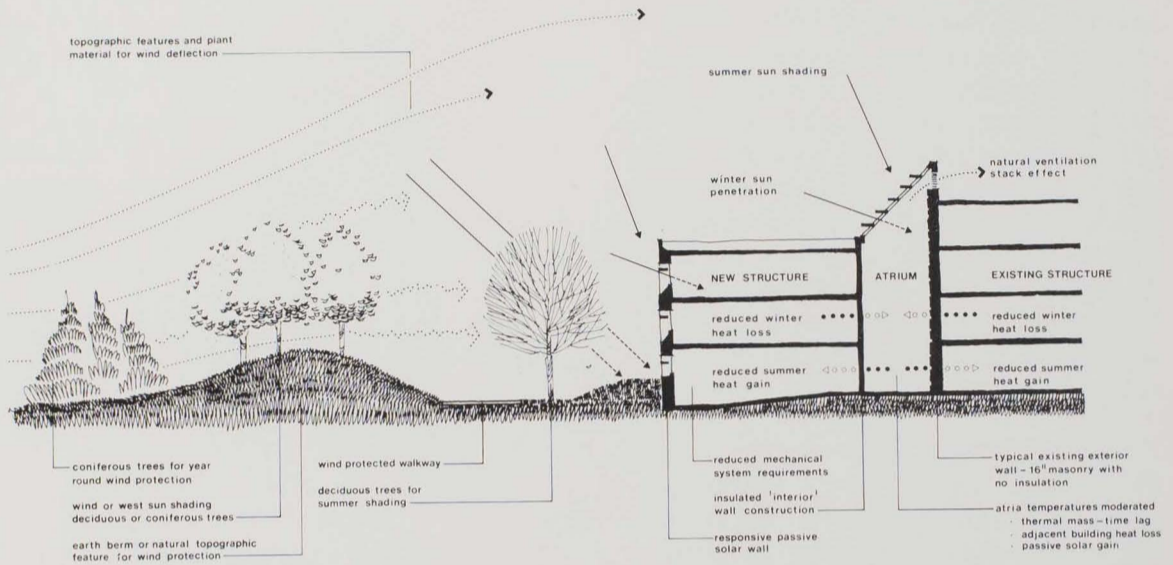

81. Energy implications of landscape, topography and atria

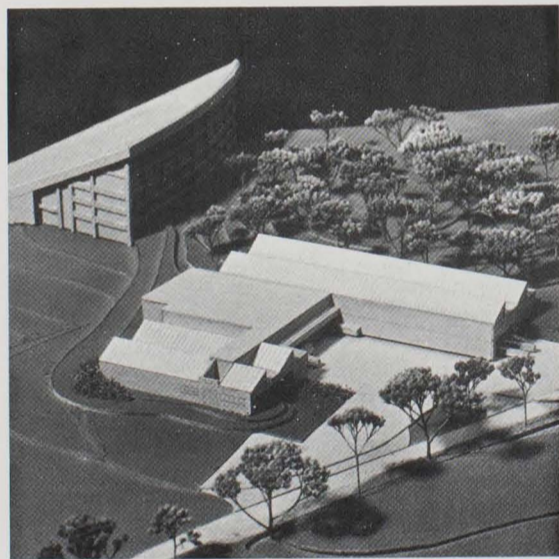

82. Food processing and storage facility

Food Processing and Storage Facility — Energy concepts

- North daylight
- Building zones based on access frequency and occupancy patterns as well as functional energy demands
- Earth-sheltering along north facade
- Air lock delivery doors
- Integrated heat recovery systems
- Ice storage system
- Sawtooth roof provides partial high-ceiling area for north light, natural ventilation requirements, horizontal vent discharge, and reduced total building volume

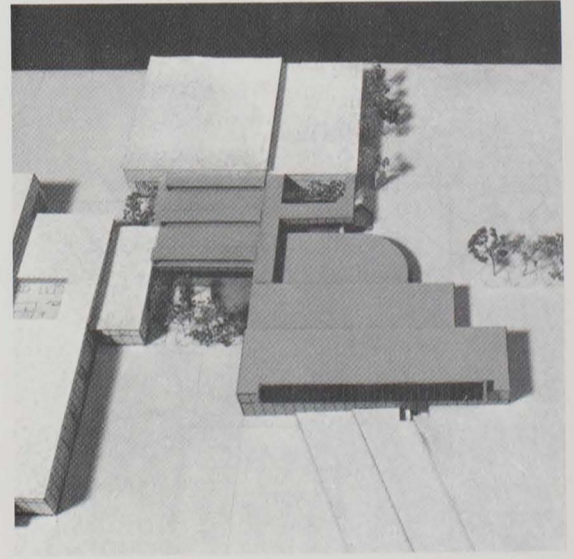

83. Forest products center

Forest Products Laboratory — Energy concepts

- Passive solar light monitors for lighting requirement reduction and heating of return air
- Direct gain south glass with summer sun overhang
- Reduced heat gain and loss through shared walls with existing facilities
- Plan zoning based on energy profile
- Existing structures provide protection from northwest winter winds

become a key factor in the infill concept. By selectively placing new increments of construction adjacent and parallel to the stone walls of existing buildings and enclosing the spaces between them with atria (84), significant benefits are achieved. Both the heat loss and heat gain in the existing buildings are greatly reduced. At the same time, the atrium spaces benefit from the existing buildings' heat loss and, where the orientation is appropriate, the native stone walls function as passive solar heat sinks.

The new structures also realize advantages from this interface, because a substantial area of what would, under normal circumstances, be exterior wall becomes interior atrium wall. The result is a reduction in the construction cost of the wall assembly and the supporting mechanical systems. Benefits to the University are lower operating costs and, more importantly, a bonus atrium space which serves as an enhanced circulation way, as well as an informal assembly, lounge, and study space (34).

Opportunities also exist to site new increments of construction in locations which provide shade and wind protection for existing structures. At least one major building on campus was designed with west glazing that renders it only marginally habitable. This condition persists, in spite of several attempts at remedies, short of prohibitive exterior redesign and retrofit.

Examination of new increments of construction and their locations in the Master Plan reveals many opportunities to take advantage of a full spectrum of energy-conscious design concepts. Included are opportunities to provide atrium connections to existing buildings, to take advantage of topographical features for earth-sheltered buildings, to use existing plant material and land forms for the shading and wind protection of new construction increments, to capitalize on site orientations which are suited to passive solar design, and to use new construction increments to provide shade and wind protection for existing courtyards and buildings. One current application of the infill concept is the Williams Quadrangle (87), which includes increments for the College of Business (85) and the Department of Chemistry (86).



84. Atrium

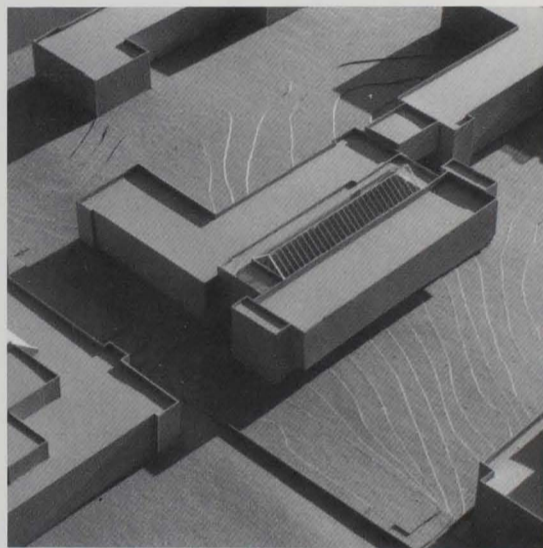

85. Business increment

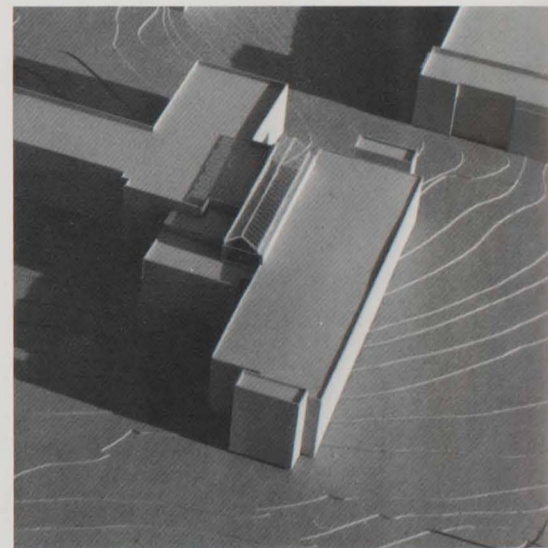

86. Chemistry increment

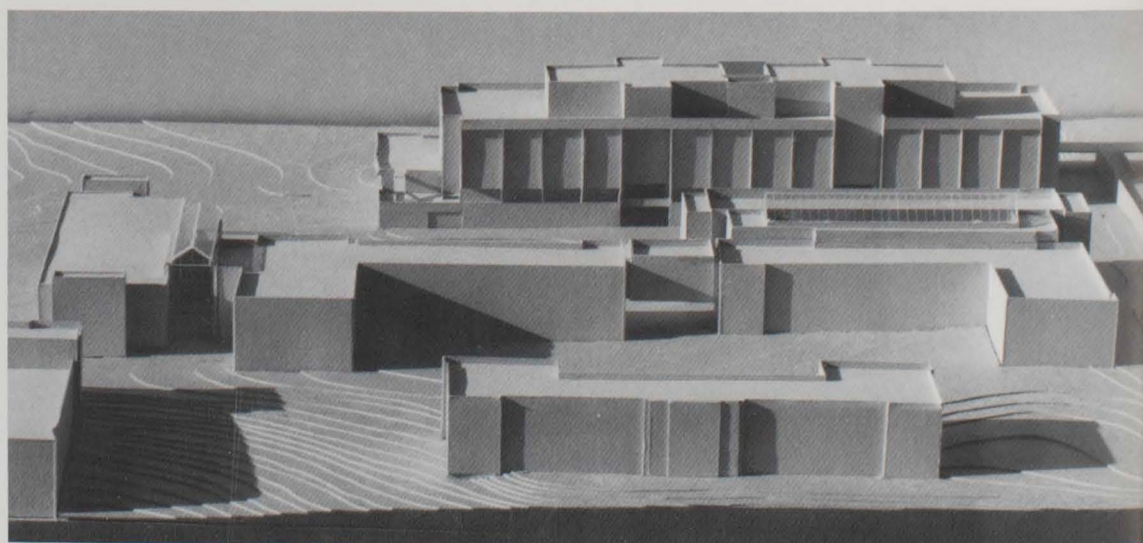

87. Williams Quadrangle





88.



89.

Communication Concepts

A goal of the Master Plan is to provide a comprehensive campus information system which ensures safety, provides clarity and understanding, and enriches the experience of the campus community and its guests. At present, the campus has no standardized signage system, a situation which has resulted in visual chaos and inadequate communication (90).

A primary concern is that users of campus can move about freely in a secure environment and, if that security is threatened, summon help swiftly. According to the Master Plan, security information and emergency telephones will be provided at key pedestrian circulation and gathering points and several remote areas of campus.

Virginia Tech's main campus covers 780 acres with more than five million square feet of buildings, and it is critical that visitors to

this large area receive clear directions to their desired destinations. Large, permanent campus maps exist at two of the major campus entries (94), with a third planned for the Price's Fork Road/Greenhouse Road entry. Telephones located at the three map sites and connected to an information center will enable visitors to locate specific individuals and offices.

The cultural, athletic, and extracurricular activities available at the University are important additions to a student's experience at Virginia Tech. To promote student participation and raise awareness, notices of campus events and University information will be provided by a network of information elements ranging in scale from building identification signs (91) to two-dimensional elements (92) to three-dimensional kiosks (93) which may include electronic media. Kiosks will be located at primary and secondary pedestrian nodes. Another Master Plan objective is to develop standardized graphics and signage for both interior and exterior applications.

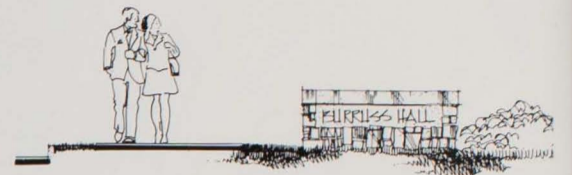

91. Building identification

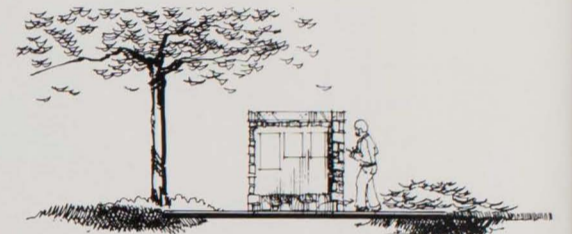

92. Information element

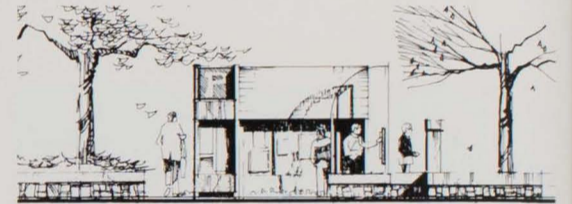

93. Kiosk

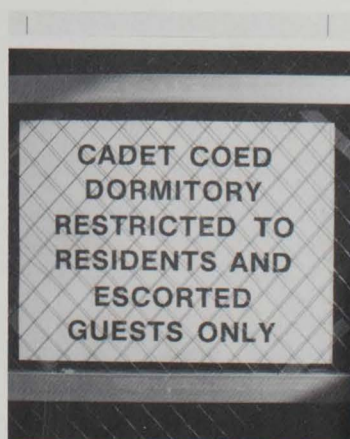

90. Campus signage

94. Campus directory





95.

"What is achieved is a place for human experience; a rich variety of forms and spaces in which to live; a structural framework that permits the expression of the individual and the participation of all the community."

Myron Goldfinger
Villages in the Sun

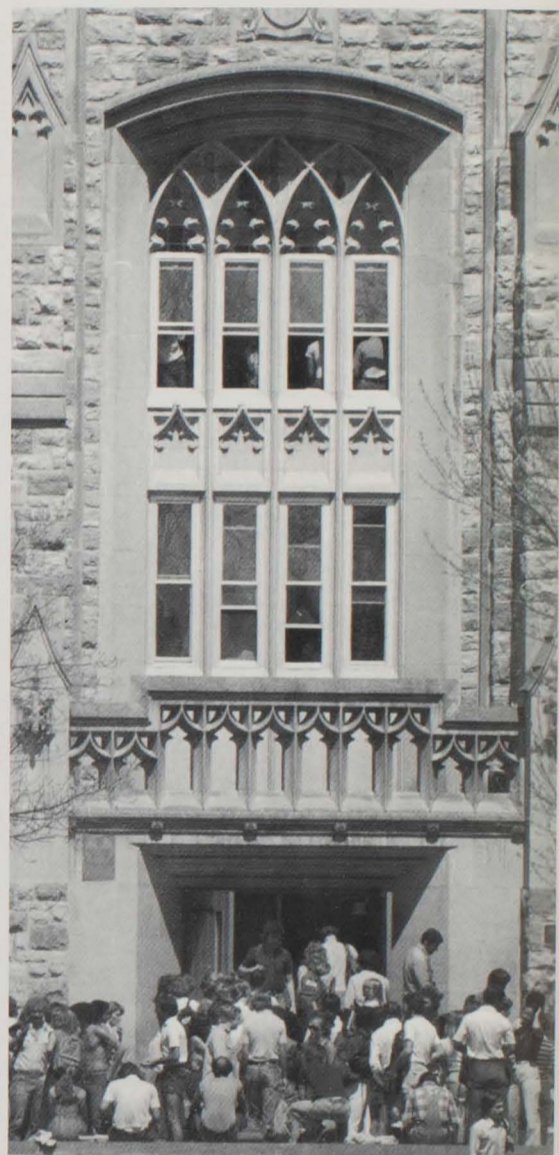

97.

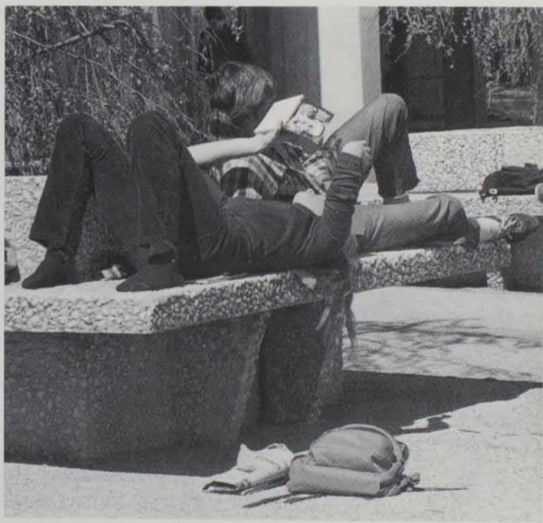

96.



98.







99.



100.

Master Plan

- existing building 
- infill increment 
- earth-sheltered increment 
- plaza 
- tree 

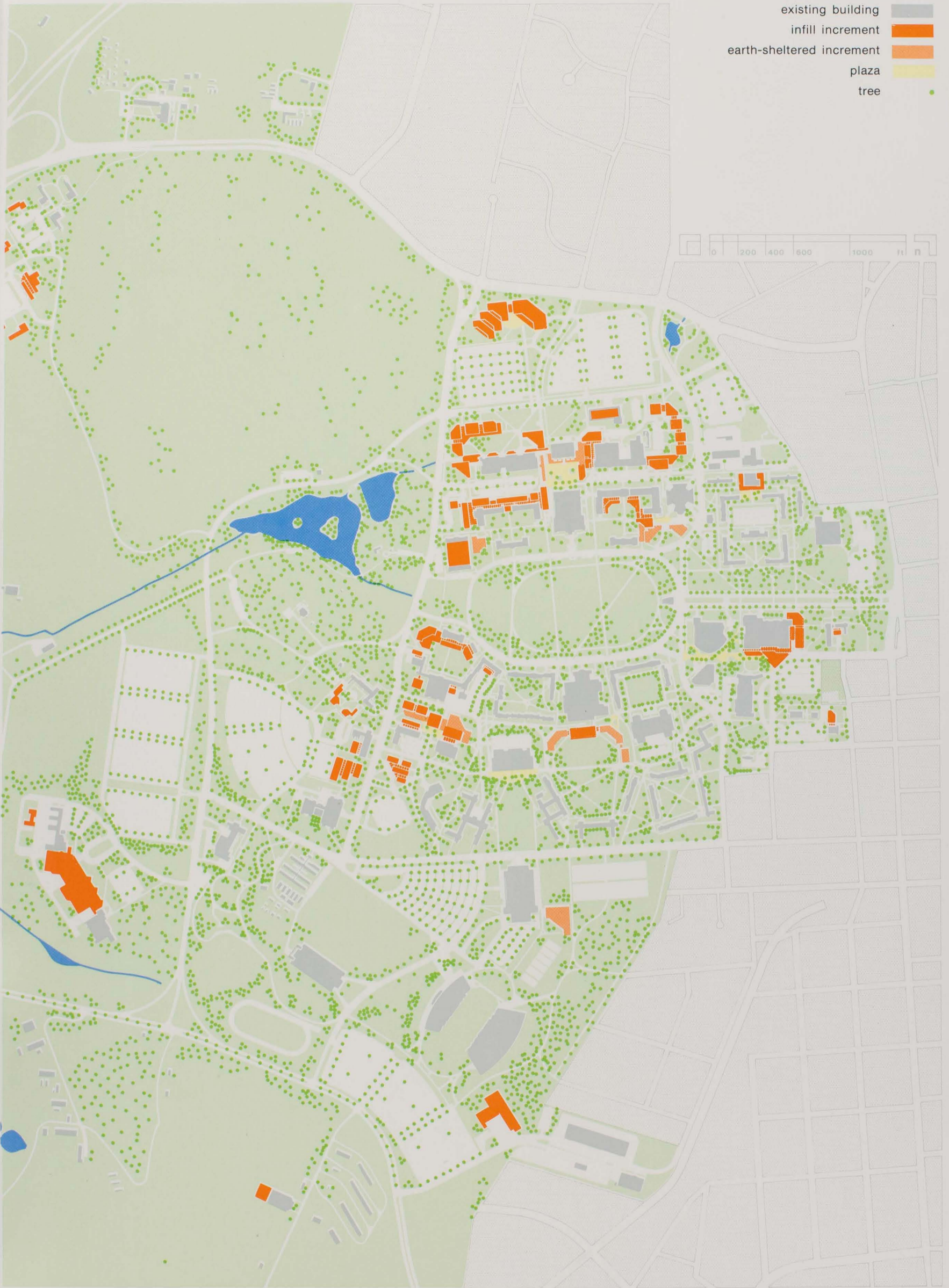

Circulation

The intent of this Master Plan is to provide a safe, efficient, and convenient circulation network which, by virtue of its design and integration with the total campus fabric, complements and enhances the visual and perceptual experiences of its users. Every attempt has been made to optimize each circulation system, within the context of an existing campus and scarce resources. The integration of these systems, as well as the resolution of conflicts between them, recognizes safety as a primary and uncompromised objective. Where issues of convenience are concerned, the solution to system conflicts favors, in order, pedestrians, bicyclists, bus passengers, and automobile users.







101. Separation

Pedestrian Circulation

The Master Plan goal for pedestrian circulation, as in all campus circulation systems, is to foster safety and convenience. Integral to this two-part goal is the provision of barrier-free circulation ways (as shown on page 46) to allow disabled persons at Virginia Tech access to all programs and services on campus, whether they are dormitories, academic buildings, or student services buildings. Perhaps more than in other campus circulation systems, pedestrian circulation is envisioned in a way that enhances the experiential qualities of the University and fosters numerous opportunities for informal education beyond the structured classroom environment.

In the past, both changes in building use and the location of new construction were predicated on the assumption that pedestrians would continue to use existing circulation patterns. The fallacy of this assumption has been proven repeatedly. Drastic changes in pedestrian patterns across the Drill Field, for example (105), occurred simultaneously with changes in academic building use. The integral objectives of this Master Plan require both an assessment of the impact of this type of change on the total campus circulation network and development of appropriate responses (106).

For many years, Virginia Tech, like most other universities, did not include considerations for handicapped circulation in either its new buildings or sidewalk system (107). Responsiveness to the needs of the wheelchair-bound increased greatly during the 1970s, though, and the University committed itself fully to a barrier-free environment (110) (see map, page 47). Consistent with its position that the application of minimum standards does not necessarily provide adequate safety and convenience for campus users (108), Virginia Tech constructed its own handicapped access guidelines by combining the most stringent state and federal standards. Ease of movement for the disabled was subsequently improved (109). But efforts to integrate handicapped facilities into the campus fabric and satisfy architectural concerns continue to be challenged by the campus' natural topography and its older buildings, which were designed with little concern for the disabled.

Efforts to achieve the primary Master Plan goal of pedestrian safety are predicated on the strategies of prioritization, separation, and integration. The first strategy, **prioritization**, establishes pedestrian circulation ways and handicapped routes as the primary circulation paths on campus (102). Implementation of the Master Plan will reinforce this hierarchy of circulation systems, paying particular attention to the safety issues present where pedestrian walks intersect vehicle roadways (shown as "vehicular conflict" on maps, preceding page).

The second strategy involves **separation** of pedestrian circulation ways from all other circulation ways to minimize the incidence of conflicts mentioned above (101). Most important is the removal of bicycles from pedestrian walks and reassignment of bicycle traffic to more appropriate routes. The Master Plan also assigns land use in a way that distances potentially hazardous recreational activities from major pedestrian paths.

The third strategy of **integration** is a response to the necessity of interactions between vehicular and pedestrian circulation (103). The objective in this plan is to bring pedestrian crossings more clearly to motorists' attention through a series of initiatives, including curb extensions, improved cross-

walks, discreet landscaping, improved sight lines, signage, and lighting. Clear, direct circulation routes will maximize safety for all pedestrians, but the Master Plan further requires that handicapped pedestrian safety be a principal concern when designing pedestrian road crossings, and that such crossings be developed on level ground and well-lighted.

The secondary goal of convenience in pedestrian circulation will be pursued through the strategies of concentration, comfort, and accommodation. Previous directional plans for Virginia Tech would have lessened pedestrian convenience, at least in terms of walking time and distance. But the **concentration** of facilities prescribed by the concept of incremental infill construction will, with few exceptions, allow pedestrians to move between extremes of the core campus in 10 minutes or less. The second strategy to enhance pedestrian convenience is **comfort**. Where appropriate, the Master Plan calls for sheltered walkways (111 and 116), building overhangs, or tunnel-type structures (112) to protect pedestrians from inclement weather. The atrium spaces (114) created as a function of incremental infill construction will be a key source of alternative inclement-weather routes. (The designation of sheltered routes on the accompanying handicapped



102. Prioritization

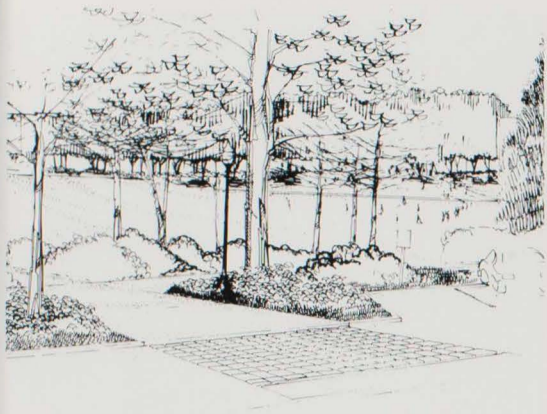

103. Integration

circulation maps excludes internal corridors which are handicapped-accessible.) In addition to sheltered routes, the plan provides for seat walls and benches throughout the system.

The third convenience strategy involves accommodation. The provision of primary and secondary pedestrian nodes (113), which serve as gathering and activity spaces, are located to serve the major campus zones and are related to specific destinations and paths. They are designed to include information kiosks, seating, landscape materials, trash receptacles, specialty lighting, and other amenities on the basis of their location and the constituency they serve.

To clarify standards further for pedestrian ways, the plan designates on the accompanying maps four types of pedestrian circulation paths, listed in order of importance:

- Major paved paths (106). These are the main connections between the primary nodes and/or destinations of campus and, as such, accommodate large volumes of users. The Master Plan calls for these paths to be sheltered, where possible. Major handicapped routes closely follow these paths and only divert where severe changes in grade occur.



104. Minor unpaved path



105. Major unpaved path

- Major unpaved paths (105). These unplanned but heavily-used routes evolved as a result of major changes in the use of existing structures, the construction of new buildings and the creation and programming of major outdoor areas. Where these routes are deemed permanent, the Master Plan calls for enhancement of them with plants and pavement. But the plan eliminates the need for several such paths through the deliberate placement of increments of construction and design features such as landscape elements, seat walls, and other barrier elements.



106. Major paved path

- Minor paved paths. These paths usually are within enclosed areas of campus, such as quads, and often connect major paths. While accommodating fewer users, they are critical to the function of the University and, therefore, subject to the same standards and safety and enhancement objectives as major paths.

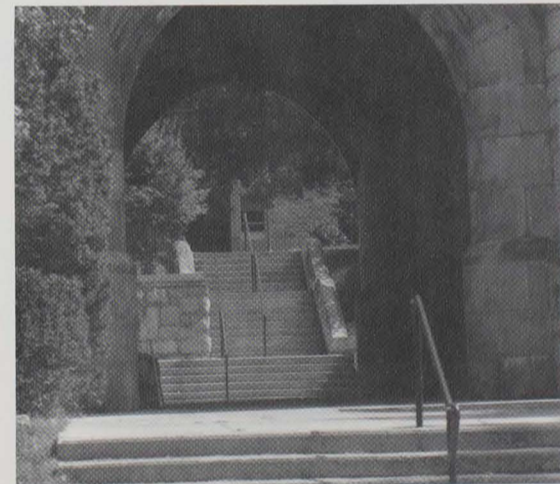

107. Topographical barrier

- Minor unpaved paths. These are spontaneous paths, caused by secondary shifts in activity. The Master Plan prescribes the paving and enhancement of these paths, where justified. Several small-scale paths are left unpaved in recreational areas (104)



108. Minimum handicapped standard



109. Curb cut

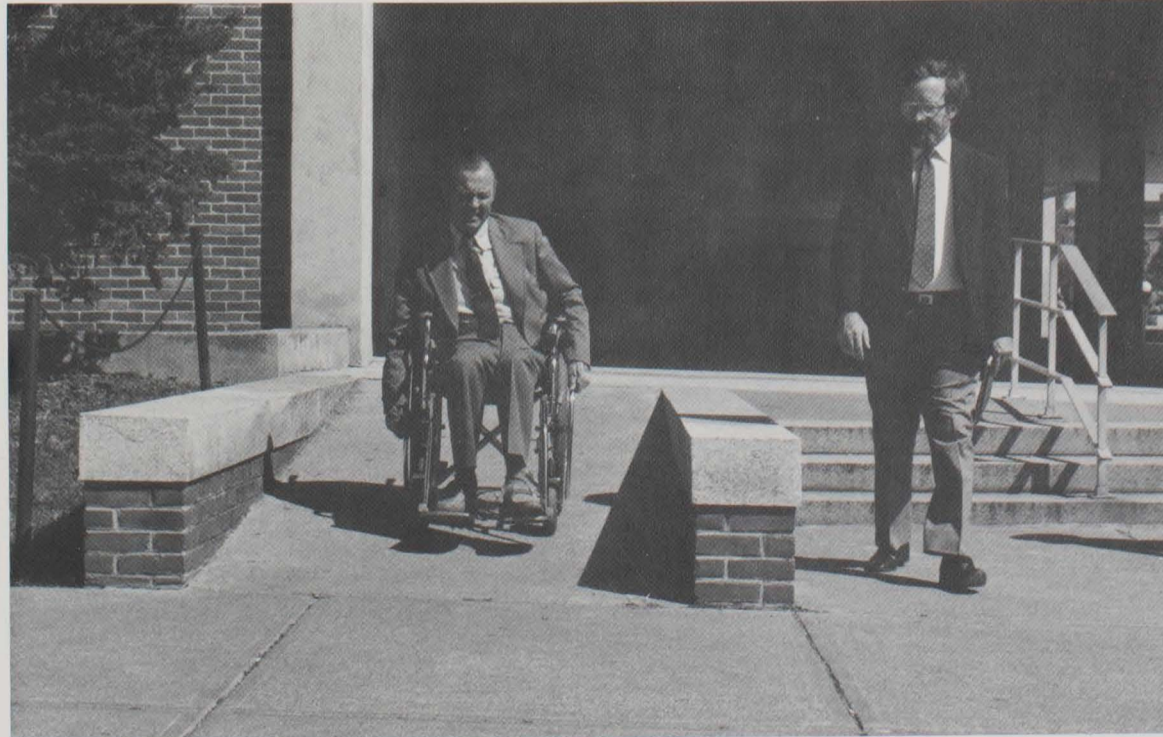

110. Handicapped ramp



111. Sheltered walkway



112. Pedestrian tunnel



113. Pedestrian node



114. Atrium

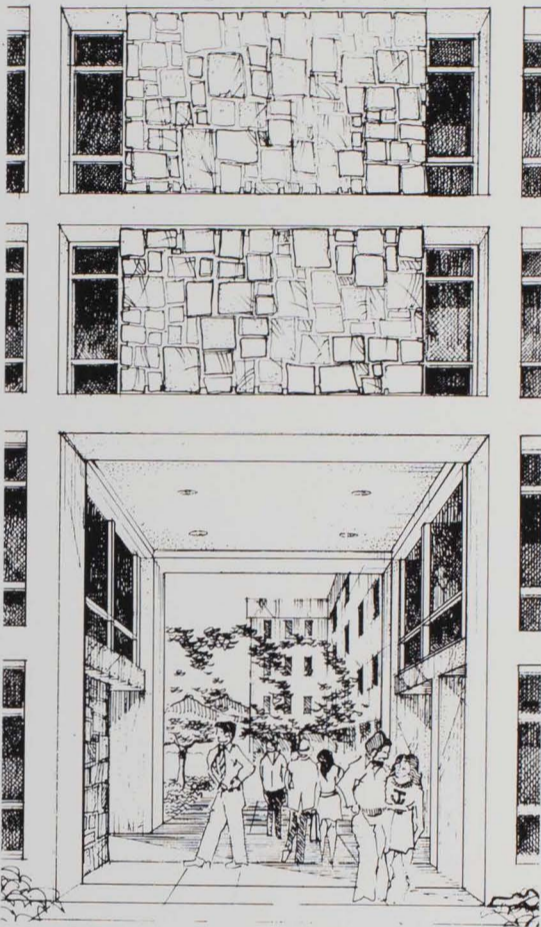

115. Portal

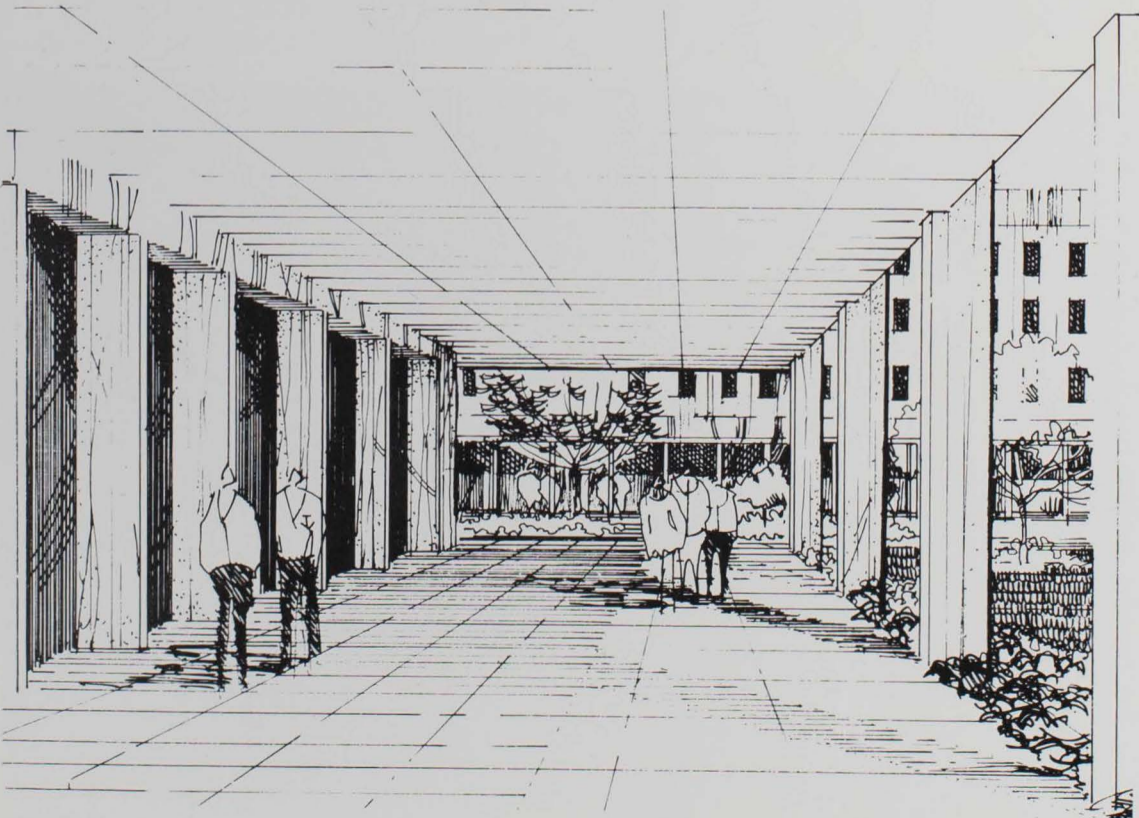

116. Sheltered walkway

This Master Plan has been developed with an underlying concern with the experiential qualities of the campus environment. As a result, the concept of incremental infill construction has as an integral part the creation of gathering and walking spaces that foster opportunities for cross-disciplinary academic interaction, the objective of which is to reinforce a "university concept," rather than a notion of unrelated colleges and one-dimensional academic experiences. Seen in this manner, circulation ways in new building increments acquire a new life; they become spaces from which the history student, for example, can view a chemistry lab or architecture studio and learn something of the campus activities in which he is not directly involved. This initiative is the first formal step toward developing the "academic street" (121), a series of multifunctional pedestrian ways which perform a passive educational role and provide an arena for students and faculty to meet spontaneously.

The Master Plan envisions that, through infill construction, several types of interior and sheltered spaces will become common elements of the campus fabric and pedestrian circulation network and will support the University's educational mission. Included among these types are:

Atria. These vital, inviting and multi-purpose spaces (114), which function as a seam between existing buildings and new increments, are intended to accommodate circulation and provide lounge and other support facilities.

Portals. These penetrations have been used often in the older, core campus buildings as routes to the quads (117). The provision of portals in new increments of construction (115) allows the development of a responsive circulation system where structures are compatible with, and not barriers to, convenient circulation.

Building links. These overhead walks or bridges form a distinct connection between structures and provide sheltered circulation at ground level. The first such connection to be realized under the infill plan is the second- and third-floor link between Pamplin and Robeson Halls (120), which will not only improve

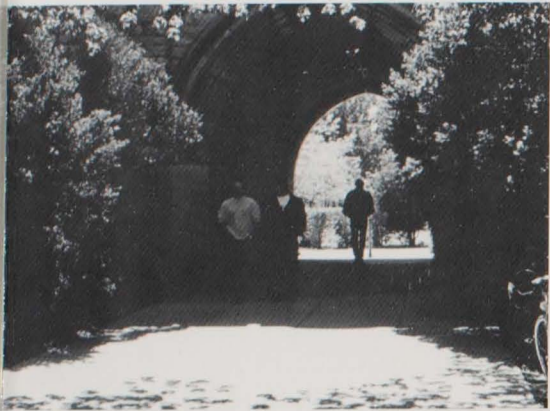

117. Portal

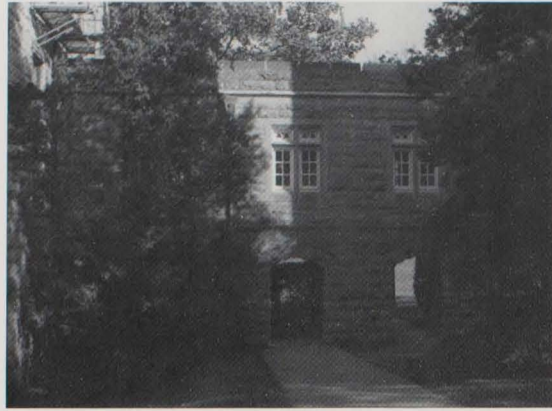

118. Building link

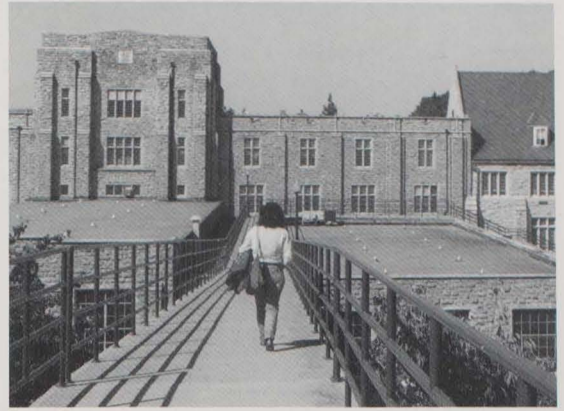

119. Pedestrian bridge

the circulation convenience of the users, but increase the functional value of both structures. This linking element, like most other proposed links, differs from the few existing examples (118) in that it includes programmed space and is not solely a pedestrian bridge.

Certain aspects of handicapped circulation, as illustrated in maps on the following page, are addressed in addition to the general issues raised previously. First, difficulties caused by variations in topography must be resolved by eliminating steps, providing alternative routes (119), and creating vertical access within structures. Infill planning includes the placement of increments of construction adjacent and connected to buildings with vertical circulation barriers, a practice which provides the disabled full access.

Second, accommodation of the visually impaired is an equal concern. For them, the Master Plan provides unobstructed pedestrian routes and access to buildings, with consistent reference points to aid orientation and movement. Braille lettering is provided at elevators and selected vending areas and restrooms. The Master Plan's intent is to significantly expand this effort.

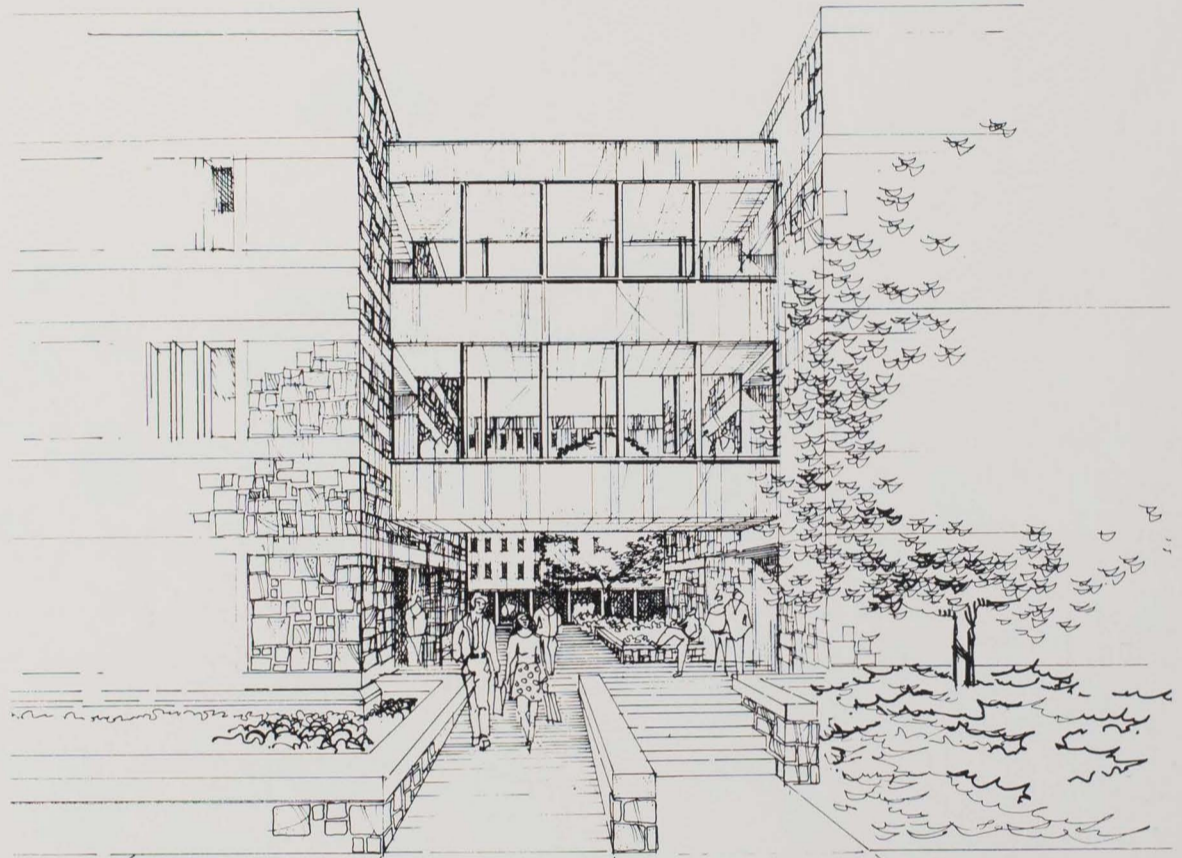

120. Building link

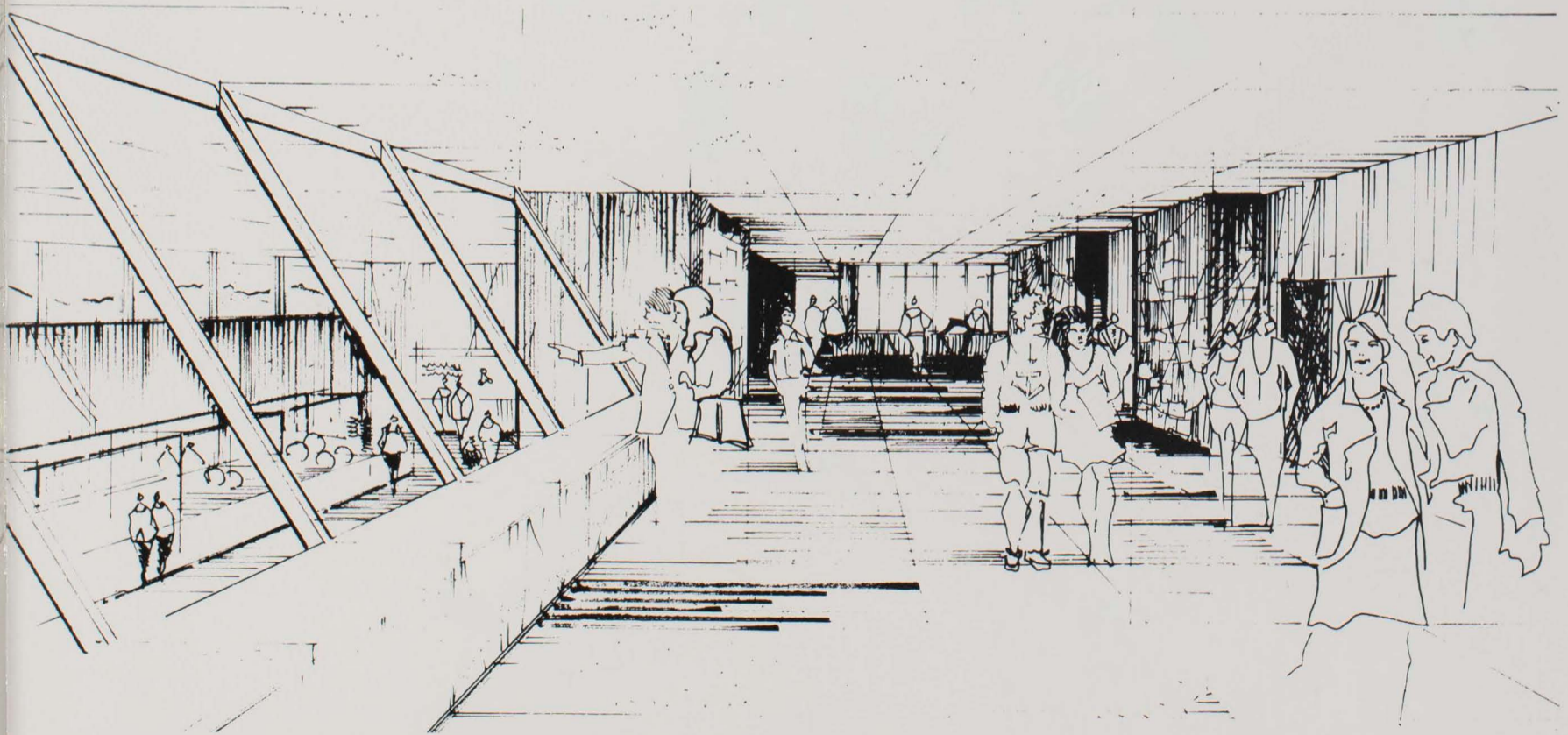

121. Academic street





Bicycle Circulation

Bicycles have boomed in popularity on campus, with some 7,500 bicycles in use at Virginia Tech in 1983. The goal of the Master Plan is to provide safe and convenient bicycle routes and permanent storage areas (as shown on page 51) which do not conflict with pedestrian and vehicular circulation. In addition to safety and convenience to cyclists, this plan addresses a third goal of security for stored bicycles.

Bicycle routes were a topic of discussion in 1974, when the town of Blacksburg first proposed routes connecting the campus and segments of the community. The University subsequently committed itself to establishing bicycle lanes in conjunction with road improvements and created two bike lanes on Stanger Street that predated the town's. By the end of 1978, Blacksburg's bike routes were taking shape and a bike trail from campus to a major housing complex west of campus was built with private funds.

To ensure the primary goal of safe travel for cyclists and reduce their need to ride on public roads alongside motor vehicles and on sidewalks where they conflict with pedestrians, the Master Plan provides for a network of bicycle circulation (shown in maps on following page) based on three types of campus bikeways, in order of their safety value:



122. Bike trail

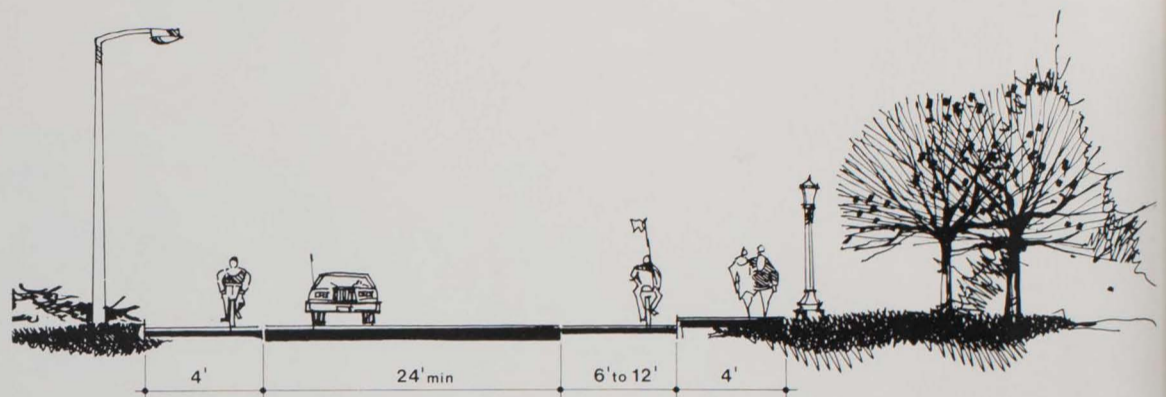

123. Bike lane

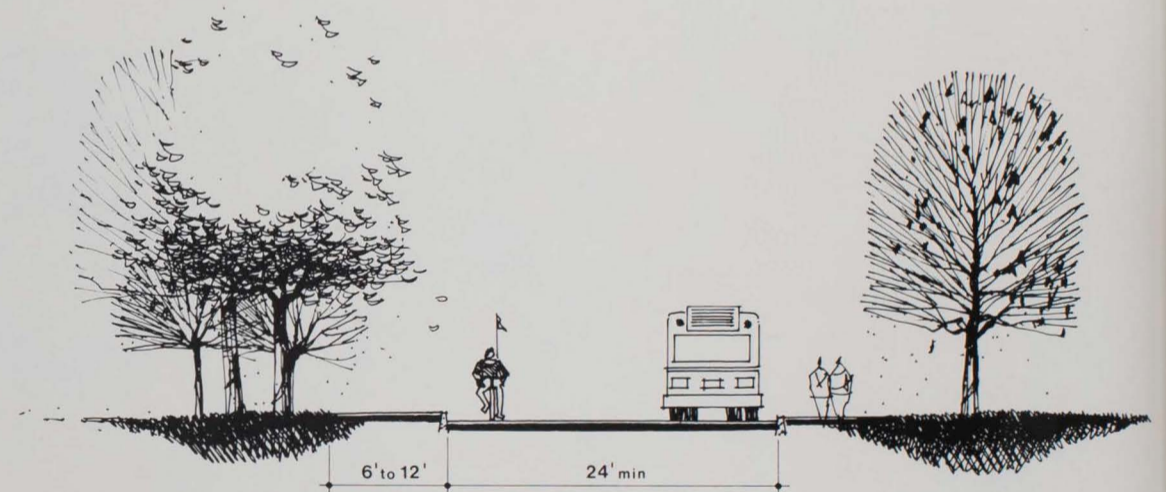

124. Shared roadway

- **Bike trails.** These are separate roadways intended for exclusive use of bicycles (122), though because of their smooth surfaces and gradual slopes, they are used frequently by joggers and pedestrians.
- **Bike lanes.** These bikeways are separate lanes painted adjacent to vehicle lanes on public roads (123). The area where Stanger Street enters the campus is an example where curb lanes are reserved for bicycles. While there remains a danger of motorists straying into these bike lanes, adequate signage and public enlightenment reduce this risk to cyclists.
- **Shared roadways.** These routes, while specifically signed, are shared with other vehicle types (124). Because cyclists are bound by traffic regulations, they are compelled to move with the flow of traffic. As the least safe of the designated bicycle routes, shared roadways will be discouraged by provision of alternative bike trails and lanes, where feasible.



125. Conflict



126. Convenience



127. Permanent storage



128. Sheltered storage

In addition to safety of the cyclist, the plan concerns itself with safety from the cyclist (125). It provides for signage prohibiting cycling on pedestrian ways in support of the University's policy to that effect.

The secondary goal of **convenience** is achieved by ensuring that this circulation system provides access to the major campus zones and reduces the distance bikes must be walked through pedestrian zones to reach storage areas (126). The Master Plan also calls for bicycle racks to be grouped according to need in permanent, hard-surfaced locations adjacent to major destination points (127).

The third goal of bicycle circulation on campus is **security of property**. Current facilities for bicycle storage offer poor protection from the elements, vandalism, and theft. This plan provides for bicycle storage under building overhangs and canopies wherever possible. Good examples are Squires Student Center and Newman Library (128). Provision of bike storage is one of many criteria used in developing increments of infill construction, and it is envisioned that bike storage will be included in the planned atria. The Master Plan also provides bicycle storage locations that are visible and well-lighted (129) — steps intended to reduce vandalism and theft.



129. Sheltered storage







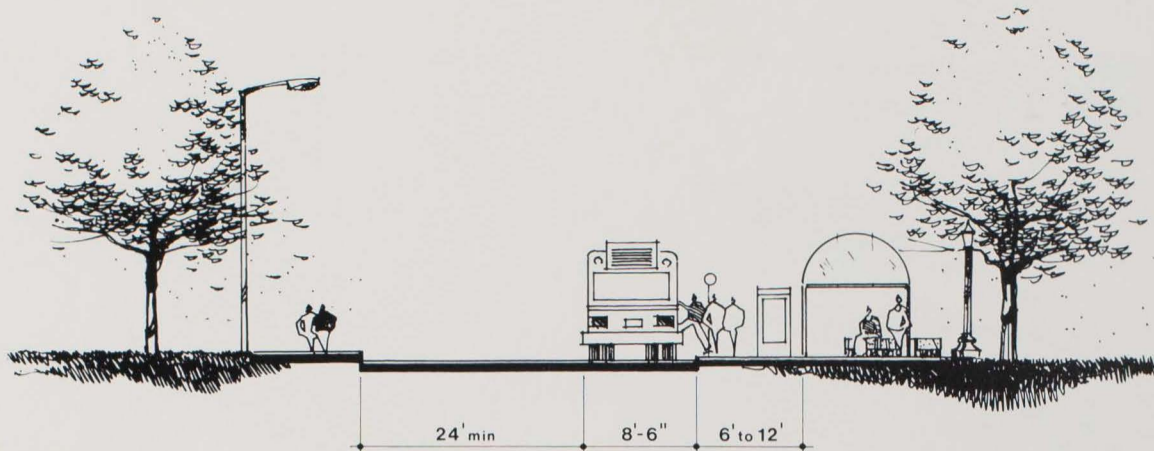

130. Proposed bus shelter

Bus Transportation

Blacksburg Transit has become a primary means of transportation for students, providing convenient campus access to a bus ridership that is projected to peak at 1.3 million rides annually. The goal of the Master Plan is to maximize the safety and convenience of those rides and the activity associated with them.

Blacksburg Transit began in 1983 with eight buses and three routes serving the primary campus zones and main destination points in town. But use of the buses far exceeded expectations of 800,000 riders yearly, and the transit fleet soon proved inadequate.

Its eight-bus complement was increased to 14 to accommodate demand from the University community. During its first year alone, the system had 1.2 million riders and produced an unexpected windfall: Parking demand dropped 36 percent in commuter lots and traffic congestion on campus was noticeably reduced.

Students comprise approximately 95 percent of the ridership and, because the system is underwritten by University fees, they need only show a valid ID card to ride. The system affords convenient travel around town and campus, operates long hours, and offers campus drop-off times calculated to coincide with class schedules.

Safety was a major concern from the inception of the bus system. The University and town worked closely together in locating routes and stops and selecting buses

which campus roads could accommodate. Bus stops were located according to criteria which centered on the volume and complexity of pedestrian circulation near proposed locations and considerations of vehicular traffic near such stops. Where possible, bus stops were located away from heavy or complex traffic patterns to minimize danger to bus riders embarking or debarking.

The physical capacity of roads was also of concern, considering that many campus roads originated decades ago and were intended to carry only automobile traffic. Another important consideration in selecting routes was the ability to maintain schedules along heavily traveled roads (131).

As the system operates now, minor shifts in routes and stops occur during the evenings, primarily to give students safe and immediate access to dorms and to serve resident student parking lots.

Issues of convenience played a significant role in planning decisions regarding Blacksburg Transit. Stops were located in the academic, service, and residential zones and near major destination points on campus to ensure riders a short walk to their desired destinations. Some changes in these locations have taken place to minimize vehicular congestion and noise from buses near classroom buildings. Implementation of the Master Plan will stabilize existing bus stops and provide benches, information elements, paved surfaces, and trash receptacles at them (130).

A convenience objective of the plan is that bus stops be well-protected from inclement weather. Because of their locations adjacent to bus routes, five building lobbies offering excellent weather protection are designated in the Master Plan as bus lobbies. These bus lobbies are in Squires Student Center, Animal Sciences, Cassell Coliseum and, in the evening, include War Memorial Gymnasium and the Guard Pavilion at the I Parking Lot. As new building increments are added to the core campus, it is envisioned that opportunities to expand this level of convenience will arise by providing direct access from bus stops into the new interior academic street. The Master Plan calls for bus shelters at major stops where existing shelter is unavailable.

Blacksburg Transit continues to operate three bus routes linking town and campus: the Hethwood-Windsor Hills route connects two major housing complexes on the east and west ends of town; Tom's Creek Loop route brings riders to campus from complexes on the north side of town; and the North/South Main Street route serves the remaining areas of town. These routes converge at a common transfer point in the pedestrian zone by Squires Student Center and Library Plaza.

The Master Plan removes parallel parking on the Drill Field's south side to ease the congestion caused by buses circling the Drill Field. Revision of bus routes and stops is anticipated with yearly assessments of the system.



131.



132.



133.





Vehicular Circulation

Thousands of automobiles enter the campus proper each day and bring with them the potential for serious traffic problems. The intent of the Master Plan is to ensure congestion-free traffic flow on direct, properly-scaled routes as a means toward the goals of safe and convenient vehicular circulation. This means eliminating existing circulation problems and, as incremental infill construction proceeds, avoiding those that can be anticipated.

In exercises leading to the Master Plan, roadways on campus were classified in four ways — very heavy, heavy, moderate, or light — according to their normal volume of traffic. This analysis helped identify areas of dysfunction and congestion in the Campus Plan, while being useful in the Master Plan to show a relative scale of movement and aid in design decisions concerning placement of drop-off points, intersections, service zones, pedestrian crossings, and parking. Maps on the preceding two pages illustrate these concerns.

In order to realize the Master Plan goal of vehicular safety, the strategies of prioritization, separation, and integration have been employed. **Prioritization**, as indicated earlier, establishes vehicular circulation as the lowest priority in campus circulation systems. The intent of this plan is to ensure that, at points of potential conflict, private vehicles defer to pedestrians, bicycles, and buses.

This leads to the second strategy, **separation**, which calls for separating pedestrian, bicycle, and vehicular circulation ways wherever possible. One example is eliminating the use of pedestrian ways as building service routes (135) (shown on accompanying maps as non-roadway service). Other actions separating vehicular and pedestrian traffic include the realignment of Southgate Drive north of the Duck Pond and elimination of through traffic between Wallace and Hillcrest Halls and on streets in the power plant area.

Finally this plan recognizes that components of a viable campus circulation system must border and intersect in a safe, efficient manner. To this end, the strategy of

integration has been articulated and employed to ensure a vehicular circulation system which provides for safe access to major destination points, passenger drop zones, parking areas, and key pedestrian circulation ways. This plan recognizes critical intersections of pedestrian and vehicular circulation and, in an effort to ensure pedestrian safety in these zones, it incorporates changes in roadway materials, provision of adequate sight lines, and use of appropriate signage (103) (see pedestrian circulation).

Achieving the goal of vehicular convenience is dependent on a system of clear, direct, uncongested routes to key campus destinations. Past traffic congestion around the Drill Field prompted the University to develop an inner thoroughfare (134) comprised of Stanger Street, Kent Street, Washington Street, Greenhouse Road, and Perry Street.



135. Pedestrian/service conflict

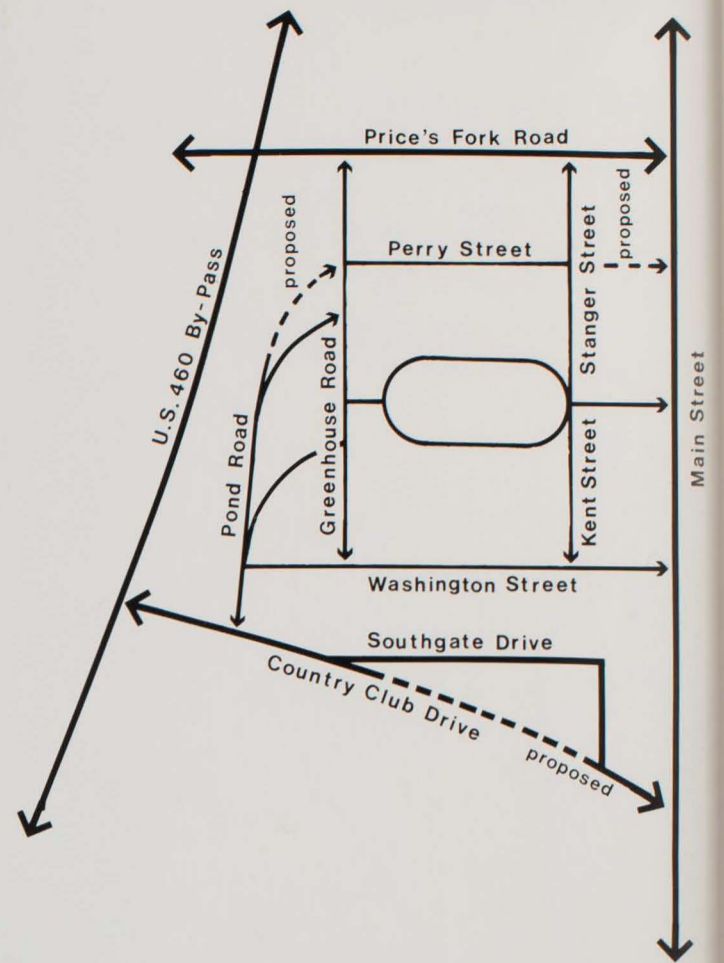

134. Primary road network

This arterial route relieved peak hour back-ups and improved the distribution of vehicles to key campus destinations. The combined effect of recent improvements to Price's Fork Road and planned improvements to Southgate and Country Club Drives will complete an outer thoroughfare (134) to provide alternative routes for traffic not destined for the core campus. This perimeter route — comprised of Main Street, Southgate and Country Club Drives, U.S. 460 By-pass, and Price's Fork Road — greatly reduces cross-campus circulation while providing major entry points to campus.

Traffic flow is limited to 25 mph on most campus roads and 15 mph around the Drill Field, where pedestrian traffic and congestion are greatest. Since all campus roads are part of the Virginia State Highway system, they, with few exceptions, meet accepted highway standards for road widths, turning radii, sight lines, and signage.



136. Permanent "improved" parking

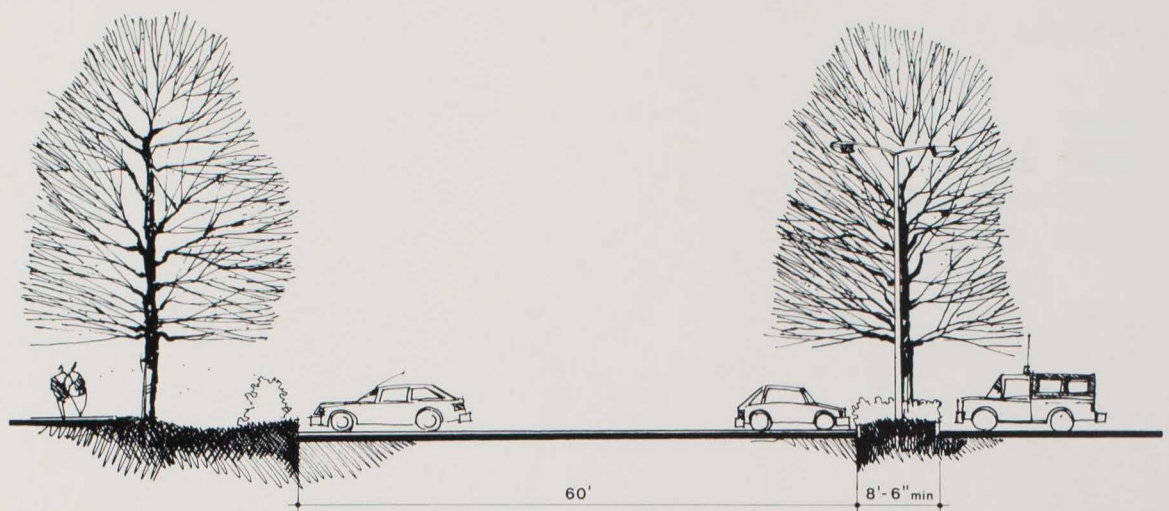

137. Perpendicular bay standard (stall width 8'6")

Parking

The goal of the Master Plan is to ensure adequate, appropriately located, and effectively designed parking in lots which are safe and convenient. These lots will be permanently developed to contribute to the overall visual and functional quality of the campus which, with some 11,400 parking spaces, has a qualitative rather than a quantitative parking problem (as shown on page 58). Virginia Tech's commitment to the pedestrian and the quality of his walking environment prohibits parking associated with each building and, with a few exceptions, results in a plan which emphasizes perimeter parking supported by strong pedestrian access.

This plan prescribes strategies for achieving a desirable level of safety, convenience, and enhanced visual impact. To support the goal of safety, parking lots will be lighted and safety call boxes installed in remote lots which are frequently used in the evenings. This plan, shown on page 59, also proposes the removal of parallel parking on the south side of the Drill Field, because the roadway is too narrow to accommodate comfortably the heavy concentration of bicycle, automobile, bus, and pedestrian circulation. Other safety measures of this plan include ensuring adequate sight lines and turning radii, clear circulation patterns, and appropriately scaled and located entries.

With regard to parking convenience for campus users and relative ease of access to their campus destinations, the Master Plan denotes five parking categories: Resident student, commuter student, faculty/staff, metered, and special use. Location is the key criterion in making these lots convenient.

- **Resident student.** There are three permanent locations for this category, as shown on the Master Plan map. Bus service is located or proposed to serve these locations in the evening hours for convenience and safety. Because these are primarily storage lots, their locations are least convenient to the core campus.
- **Commuter student.** The three commuter student lots are easily accessed and more convenient to the campus core than are the resident student locations.

- **Faculty/Staff.** This parking is assigned to a number of small lots on campus and to most street parking spaces located near academic buildings. These locations which provide convenient access are restricted from 6:30 a.m. to 5:30 p.m.. After 5:30 p.m., Faculty/Staff and Commuter Student parking areas are available for general use.
- **Metered.** A small portion of the parking inventory is metered to ensure access and frequent turnover. These metered spaces are designated for visitors only, faculty/staff only, or general use, based on the specific destination they serve.
- **Special use.** This parking category is based on special or site-specific needs. Handicapped parking, which is the highest priority type under this designation, is located adjacent to all major facilities and handicapped circulation routes. The balance is simply designated by destination or use. Examples include: Recreational vehicle parking associated with athletic events; service parking; short-term visitor parking; short-term faculty/staff parking; general visitor parking; golf course parking; and overnight parking for Continuing Education Center guests. Visitors to campus can obtain passes which permit parking in any legal parking space. Overflow parking for varsity sporting events is accommodated in multipurpose fields near the athletic area. The Master Plan also provides specifically-designated spaces for vehicles servicing campus buildings.

The only critical campus parking problem exists in the student services zone, which encompasses Newman Library, the University Bookstore, Squires Student Center, the Continuing Education Center, and Henderson Hall. The disparity between supply and

demand in this zone, which serves large numbers of campus users, is a problem exacerbated by its proximity to downtown Blacksburg, where parking space is inadequate. Virginia Tech has worked with town officials in identifying solutions to interrelated parking problems; one result has been a 100-space expansion of the lot east of Shultz Hall, which will relieve parking pressure. In addition, the proposed relocation of the Continuing Education Center to the Price's Fork/Greenhouse Road site will significantly reduce parking demand in the student services zone.

The third goal of **visual and functional enhancement** reflects this plan's commitment to ensure that all elements of the campus contribute to its aesthetic and functional quality. Critical to this commitment is eliminating the negative visual impact of large gravel lots which greet campus users upon their arrival. In the past, the desire to locate parking as close to destinations as possible, combined with a development plan that expanded to the campus periphery, resulted in the designation of temporary parking lots that, because of their "temporary" label, received few of the amenities necessary to a quality environment. Under this plan, parking lots are designed to reflect topography, perimeter conditions and pedestrian circulation requirements and will include curbs, paved surfaces, lighting, landscape material, and signage (136).

In addition, the campus parking capacity has been increased through improved layout and introduction of more efficient space standards. The implementation of perpendicular parking with stall widths of 8'6" and curb-to-curb dimensions of 60 feet reduces the space required per car by 20 percent over previous 10-by-64-foot standards (137 and 138).

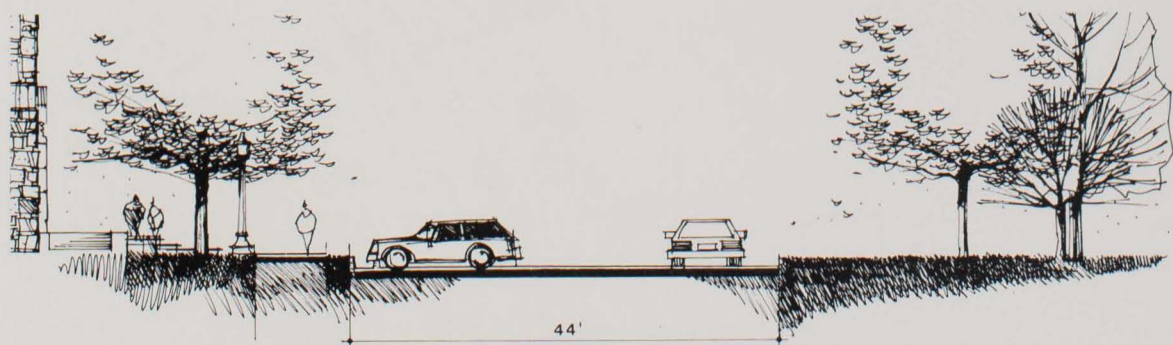

138. Perpendicular bay/roadway standard (stall width 8'6")



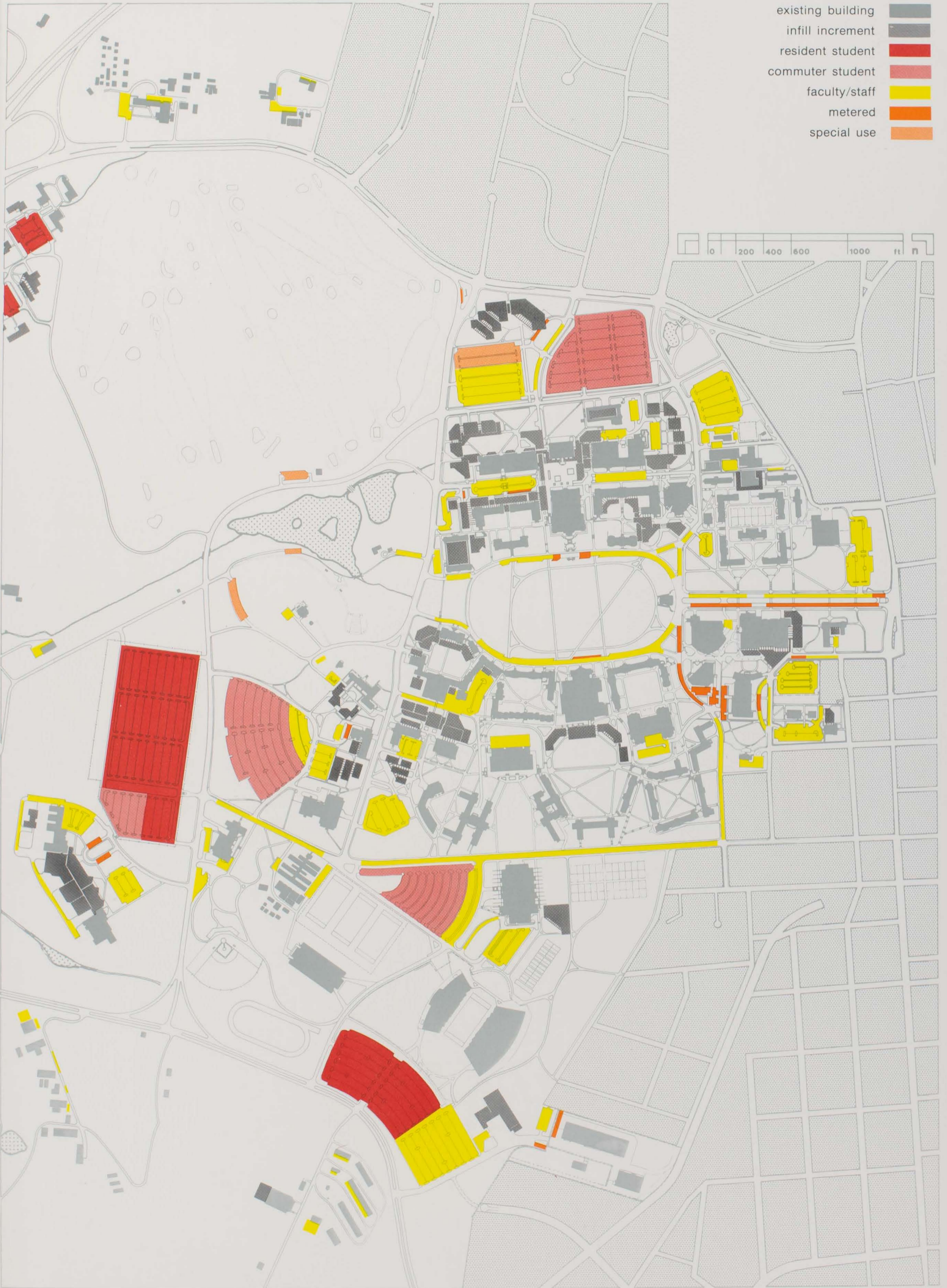

Safety

The most effective safety strategy is prevention. But, while Virginia Tech's commitment to this strategy is unequivocal, emergencies will occur. Within this context, the Master Plan establishes the safety of people as the first priority and the protection of property as secondary.





Health and Safety

The goal of this Master Plan is to ensure a campus environment as free as possible from recognized physical problems and one which accommodates, in the safest manner possible, the acquisition, transport, storage, use, and disposal of hazardous substances essential to the teaching and research mission of the University.

The evolution of Virginia Tech into a comprehensive research and teaching institution has resulted in the emergence of many safety concerns related to existing campus buildings, their physical condition, and the functions they house. Increases in campus population, when measured against a disproportionately small increase in physical space, have led to building occupancies which strain the capacities of their safety features (140). This condition is exacerbated by the demands placed upon the physical plant by changing functional need (139). Classroom conversions to office space (141), while programmatically justified, result in extended and frequently complex internal corridor systems which, in turn, decrease inherent safety. Of even greater concern, conversion of classroom and office space into research laboratories (142) invokes much more demanding safety and health requirements.

Accommodation of these environmentally demanding research activities includes, by necessity, the supply, storage and removal of hazardous substances. Some of these

substances and the hazards associated with them were not even known at the time many of our older buildings were constructed (144).

All too frequently, conversion of conventional classroom space to this type of environmentally demanding and sophisticated use has been undertaken on an ad hoc, site-specific basis, with limited analysis and evaluation of the overall implications for building safety. There also are campus buildings which were built under much less stringent codes than today's, codes which reflected the safety needs of simpler buildings housing simpler activities (145).

In 1974, Virginia Tech established the department of Safety and Health Programs, which was charged with the responsibility for identifying and resolving safety problems related to the acquisition, handling, and disposal of hazardous materials, the use of those materials, and the appropriateness of the systems, equipment, and environments associated with them (147). This department also evaluates existing structures for fire safety, ensures code compliance of new structures, provides personnel safety programs and, in general, oversees the University's fire safety program.

Careful attention was paid to locating the central processing facility for surplus and hazardous materials and planning the vehicle routes followed in transporting such materials from buildings where chemicals and other raw materials are used. Safety department workers follow an approved campus route to collect the

material — consisting mostly of surplus chemicals from laboratory, agricultural and maintenance activities — and transfer it to the central handling facility, where it is evaluated and held temporarily for pickup or other disposition. Radioactive material is collected in a like manner. Commercial vendors under contract for material disposal also follow a prescribed route to and from the collection facility, avoiding busy roads.

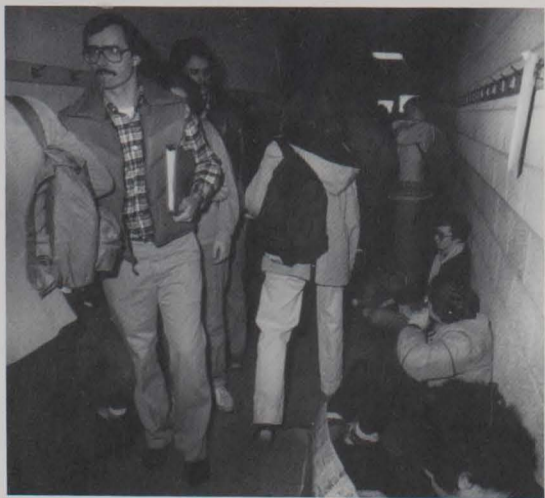

140. Occupancy overload



141. Classroom-to-office conversion



142. Classroom-to-laboratory conversion



139. Changed functional need



143.



144. Davidson Hall, constructed 1938



145. Lane Hall, constructed 1888



146. Hazardous material storage

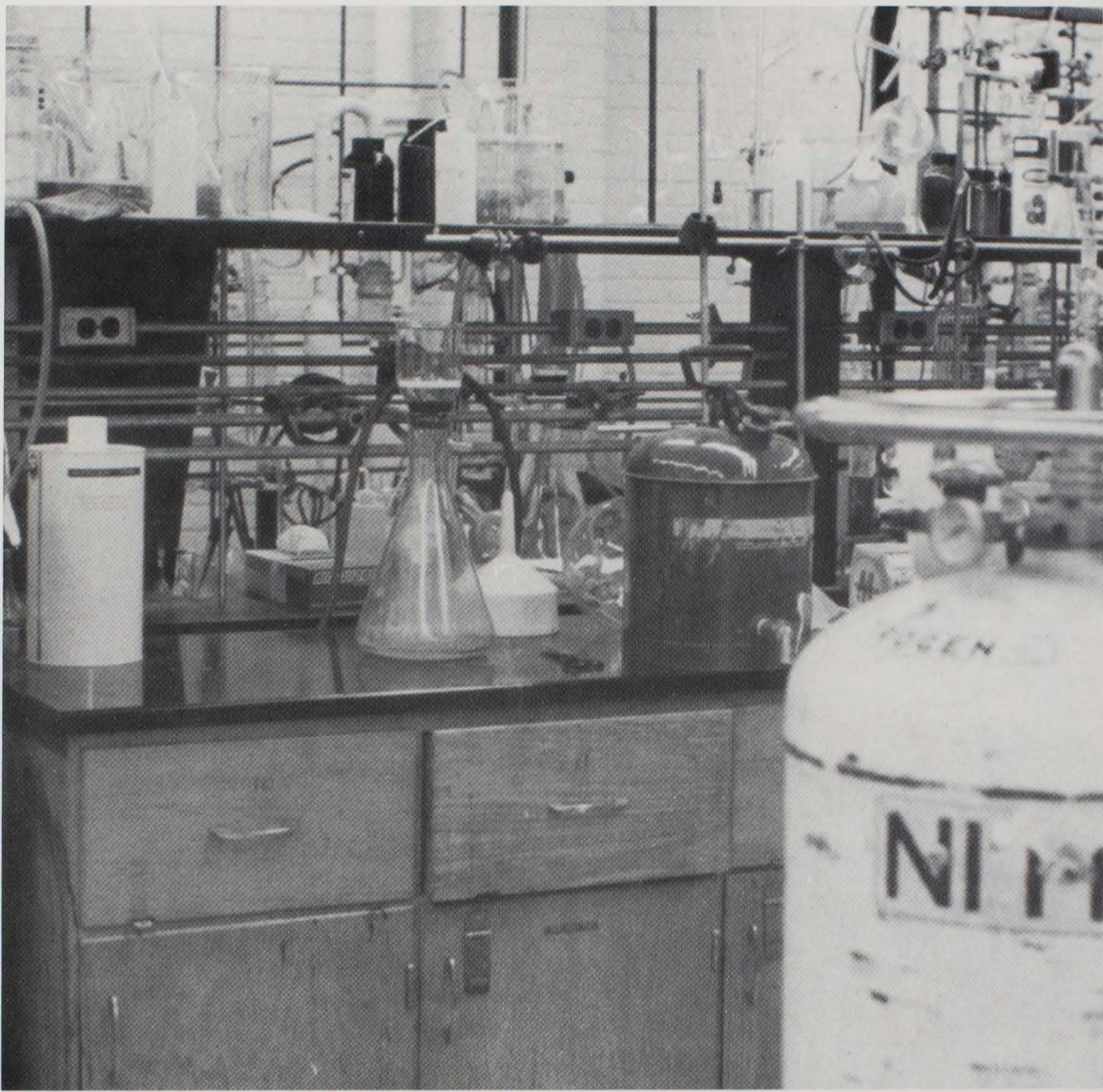

147. Environmentally demanding laboratory space

In concert with Safety and Health Programs, major campus buildings were analyzed to identify opportunities to maximize user safety. To improve conditions in buildings with safety concerns, several approaches were developed. The first is **monitoring and controlling** the use and storage of radioactive, chemical, and flammable materials (146). The second deals with **eliminating** building dysfunctions, such as inadequate ventilation, inadequate space, and incompatibility of building uses and sub-systems. Third is **reducing** potential fire hazards related to excessive occupancy, existence of combustible construction materials, inadequate exitways and fire stairs, excessively complex circulation routes, and ineffective alarm systems.

This Master Plan and the strategies for its implementation provide a vehicle for aggressively resolving safety problems in several ways.

- The first strategy is to educate users to modify their activities and procedures to achieve environmental compatibility and improved safety.
- A second strategy integral to this plan and requiring no new construction is to **re-allocate** space based on functional compatibility versus expediency and territoriality.

- The third strategy is to **alleviate** safety concerns by retrofitting functionally compatible space with appropriate equipment and support systems, which are integrated with and supportive of the overall building sub-system and safety profile.
- The fourth strategy is to **regenerate** existing space according to its original intent or another use which is less environmentally demanding. Regeneration is predicated on downgrading the systems requirements of the space and usually involves removal of ad hoc, inefficient, and non-integrated sub-system components.
- The fifth and generally expensive alternative is to **renovate** existing space. Because of the cost of this method, it is imperative that the space to be renovated for a given function be selected according to its physical constraints. In order to ensure cost-effectiveness, renovations frequently will be associated with reallocations of space.
- The sixth strategy is to **create** new space by discreetly placing increments of construction adjacent and connected to existing structures which exhibit health and safety concerns. This new construction can upgrade evacuation routes and systems, provide environmentally appropriate functional space, and relieve overcrowding and dysfunction.





Emergency Response

The goal of the Master Plan is to ensure the safety of people and property, in that order, through the application of design criteria based on timely notification and response. In the event of a medical or police emergency, this plan provides a network of exterior emergency telephones as well as clear and unobstructed vehicular routes to all buildings. Where possible, alternative routes have been identified. The convenient location on campus of the Virginia Tech Rescue Squad and University Police facilitates a maximum response time of less than five minutes. This plan's response to fire emergencies is predicated on the strategies of prevention, containment, evacuation, reporting, and suppression, as follows:

The first strategy of **prevention** is the reduction or elimination of hazardous conditions and activities, as articulated in the Health and Safety section of this document.

The second strategy, **containment**, is based on early detection and extinction to prevent fire growth and spread. Sprinklers, as the most effective suppression system, are recommended in virtually all new campus structures. They also will be included throughout major building renovations and, where that is not economically or physically feasible, in hazardous areas of buildings. Where it is not practical to provide sprinklers, adequate, appropriately-maintained extinguishers are provided, with complementing education programs to ensure that key per-

sonnel are knowledgeable in their use. The next level of containment occurs through separation, which limits both the area of fire involvement and amount of available fuel. Although building codes address these issues, the University maintains that true safety frequently requires steps exceeding code compliance.

A third and particularly critical strategy in this Master Plan is **evacuation**. The first step in an evacuation plan is to alert building occupants through an alarm system. This is achieved on campus with a combination of smoke detectors, manual alarms, and personnel programs. Ensuring safe, direct means of exit in a fire emergency requires the design and maintenance of clear, unobstructed horizontal and vertical routes, properly sized to accommodate the building occupancy (148). Achieving this throughout campus requires not only strict code compliance as a minimum in all new increments of construction, but careful evaluation of the implications of use and occupancy in existing structures. Safe means of exit extends beyond structural interiors and this plan acknowledges that, prohibiting planting along building foundations and outside entries (149) to protect their safety value. This plan also recognizes that handicapped access means handicapped egress. In the case of structures where handicapped circulation is predicated on elevator service, it is essential to provide areas of refuge in the event of fire. Provisions for handicapped exit must not complicate non-handicapped routes.

The fourth strategy is **reporting**. This plan includes a commitment to the development

of fire alarm systems interconnected with the campus police and Blacksburg Fire Department to supplement normal telephone notification. Addition of the exterior emergency phone system also addresses this need.

Suppression by firefighters is the final strategy employed in the event a fire emergency is not eliminated by sprinklers, manual fire extinguishers, or other means. Critical to this effort is the provision of adequately-sized, unobstructed, and direct vehicle access routes to all campus structures — an objective realized in this plan in spite of difficulties posed by significant topographical characteristics (150) and configurations of building quadrangles. Encompassed in this objective are adequate, appropriately-located hydrants and standpipes. Supporting this strategy is the close cooperation between Virginia Tech and the Blacksburg Volunteer Fire Department in emergency planning and hazard assessment.



148. Corridor dysfunction



149. Plant material hazard

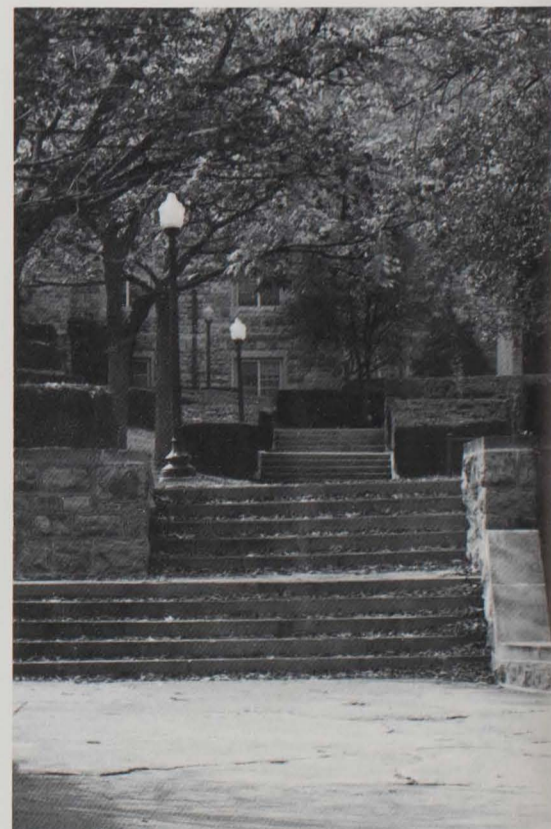

150. Obstructed vehicular access

LIGHTING

The development of the Master Exterior Lighting Plan (see plan, page 71) is based on the following goals:

- To provide adequate lighting along major vehicular and pedestrian circulation routes and to highlight critical intersections at levels commensurate with safety and convenience requirements.
- To provide adequate lighting outside of building exitways.
- To provide adequate, site-specific lighting for outdoor functions.
- To optimize the cost-effectiveness of the exterior lighting system.
- To use lighting to enhance the perceptual qualities and image of the campus.
- To use lighting to celebrate special features and structures.

The first two of these goals do not represent a significant departure from the existing campus lighting approach, except in the degree of realization and standardization of the light source. But the qualitative objective

of the second two goals — the use of lighting to create effect, provide information, and enhance visual qualities of campus — does represent a departure from previous quantitative approaches.

To achieve greater energy- and cost-efficiency, the predominant mercury vapor light sources are being converted to high-pressure sodium lights, which require less maintenance and produce substantially more light at lower cost. Conversion to sodium light sources will result in substantial annual energy cost savings, as well as owning and operating cost savings. Because of their distinctly different colors (mercury light is white and sodium is yellow) and the relatively high initial cost of converting to sodium, a phasing plan has been adopted. This plan calls for conversion by zones, starting at the campus periphery and moving inward until the Drill Field lights are changed.

In addition to bringing uniformity to light sources, the lighting standards used on campus are as follows:

- For general lighting within the core campus, the eight- and ten-foot cast iron standards (151) which have been used by the University since the 1920s. As a cost-saving measure, matching fiberglass standards were introduced recently for use in selected locations.
- For perimeter street and selected parking lot use, 30-foot aluminum standards with cobra head fixtures (152).
- Exceptions are the tennis court, stadium, special effects, special events, landscape, and flood lighting.



151.



152.

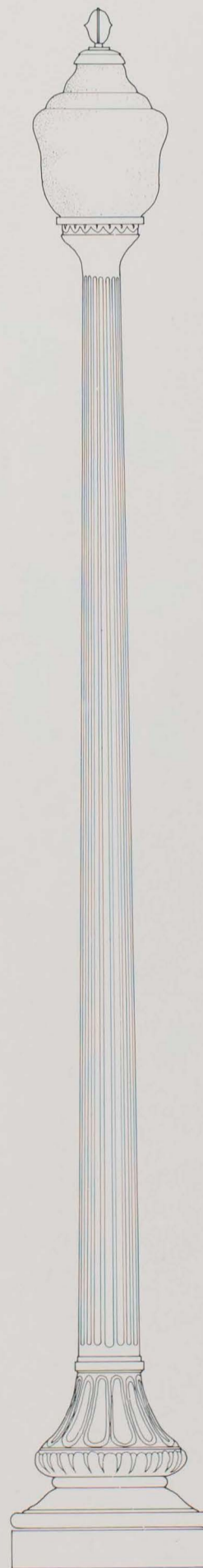

153. Virginia Tech light standard





Landscape

To create and maintain the quality of our outdoor environment, the Master Plan advocates its preservation as a reflection of the past, its enhancement in supporting the activity of the present, and a careful regard for its use in the future. This plan treats land as a valuable and irreplaceable resource.





month	temperature (°F)													precipitation totals (inches)													month			
	means			extremes						mean degree days base 65°	mean number of days				greatest monthly	greatest daily	greatest year	greatest day	snow, sleet					mean number of days						
	daily maximum	daily minimum	monthly	record highest	year	day **	record lowest	year	day **		max.	32° and below	32° and below	0° and below					mean	maximum monthly	year	greatest daily	year	day **	01 or more	10 or more		50 or more	1.00 or more	
	Jan	Feb	Mar	Apr	May	June	July	Aug	Sept	Oct	Nov	Dec	year	Jan	Feb	Mar	Apr	May	June	July	Aug	Sept	Oct	Nov	Dec	year				
43.2	23.0	33.1	75	52	1	-12	70	10	981	0	6	26	1	2.83	6.06	47	1.57	47	15	5.6	38.5	66	12.0	66	30	10	7	1.8	0.5	Jan
45.0	23.8	34.5	72	51	26	-12	70	4	856	0	4	23	1	2.90	6.48	44	1.59	45	17	4.9	18.0	64	9.0	58	16	9	7	1.8	0.4	Feb
53.4	30.1	41.8	84	45	19	2*	69	11	711	0	1	19	0	3.60	8.08	56	1.38	58	31	4.3	33.8	60	14.0	60	3	12	8	2.8	0.5	Mar
65.1	39.9	52.5	95*	57	29	17	69	1	376	0	0	7	0	3.06	5.72	49	2.12	57	5	0.0	0.5	56	0.5	56	8	10	7	2.2	0.5	Apr
73.8	48.6	61.2	93	41	22	24	68	7	150	0	0	1	0	3.46	7.25	50	2.26	44	29	0.0					11	8	2.6	0.4	May	
80.1	56.2	68.2	96	52	27	34	66	2	36	2	0	0	0	3.75	7.86	48	2.35	48	22	0.0					11	8	2.6	0.8	June	
83.1	59.9	71.6	100	52	28	41	61	10	5	3	0	0	0	4.00	7.25	70	3.00	66	30	0.0					13	8	2.6	0.9	July	
82.0	58.8	70.4	96*	59	27	37	68	29	14	2	0	0	0	3.51	7.90	52	2.88	64	31	0.0					11	7	2.4	0.8	Aug	
76.3	51.9	64.1	96	53	2	27	42	28	100	1	0	0	0	3.16	10.29	57	3.42	59	30	0.0					8	6	2.2	1.0	Sept	
66.9	41.2	54.1	91*	41	8	13	62	27	341	0	0	6	0	2.49	5.10	47	2.94	66	19	0.1	1.5	62	1.5	62	26	7	4	1.7	0.6	Oct
54.6	31.5	43.1	81	50	1	0	70	25	654	0	1	17	0	2.47	5.01	48	2.15	62	10	1.2	15.0	68	10.0	68	12	9	6	1.6	0.4	Nov
44.0	24.2	34.1	70*	56	8	-7	60	22	950	0	5	25	0	2.94	5.88	48	3.18	58	29	3.6	14.8	62	14.0	69	26	10	6	2.0	0.4	Dec
year	64.0	40.8	52.4	100	52	28	70	4	5174	8	17	124	2	38.17	10.29	57	3.42	59	30	19.7	38.5	66	14.0	69	26	121	82	26.0	7.0	year

* also on earlier dates, months, or years

** day observation was made

NOAA / Agronomy Department VPI & SU

154. Means and extremes

Climate

latitude: 37° 11' N
 longitude: 80° 25' W
 elev. (ground): 2,000 Ft.
 station: Blacksburg

Blacksburg is situated on a plateau in the Great Valley of Virginia. Elevations above sea level average about 2,000 feet in the town, with variations from 1,300 to 3,700 feet in outlying areas. The New River, draining western Montgomery County, flows northward and the Roanoke River, draining the eastern country, flows eastward.

Blacksburg has a humid continental climate modified by elevation. Winters are moderately cold and summers are relatively cool. Nearby mountains produce various steering, blocking, and modifying effects on storms and air masses, protecting the county from the extremes of winter and summer.

The mean annual temperature is 52 degrees. May and September are relatively warm, even though temperatures below freezing have been recorded during both months. The number of days annually with a temperature

of 90 degrees or higher ranged from none, during several years, to 26 days in 1953. The maximum temperature drops below freezing an average of 17 days a year. Temperatures dip below freezing about 25 days each winter month and reach zero two times yearly.

Precipitation is well-distributed throughout the year, peaking in July and hitting a low point in November. Summer rainfall consists mostly of brief showers and thunderstorms, which occur some 40 days a year. Annual snowfall averages 20 inches a year, but has varied from two inches in many seasons to a 52-inch record in 1965-66.

Prevailing winds are westerly in general, with a more northerly component in winter and southerly component in summer. The topography also affects wind, which tends to flow parallel to the northeast-to-southwest-oriented mountain ridges. Relative humidity relates inversely to temperature, being high in the morning and low in the afternoon. Average summer values drop from 80 to 50 percentile from morning to afternoon. Cloudiness is least in the Fall (averaging five-tenths coverage). Close to 40 percent of summer days have partly cloudy skies.



155. Summer



156. Fall



157. Winter



158. Spring

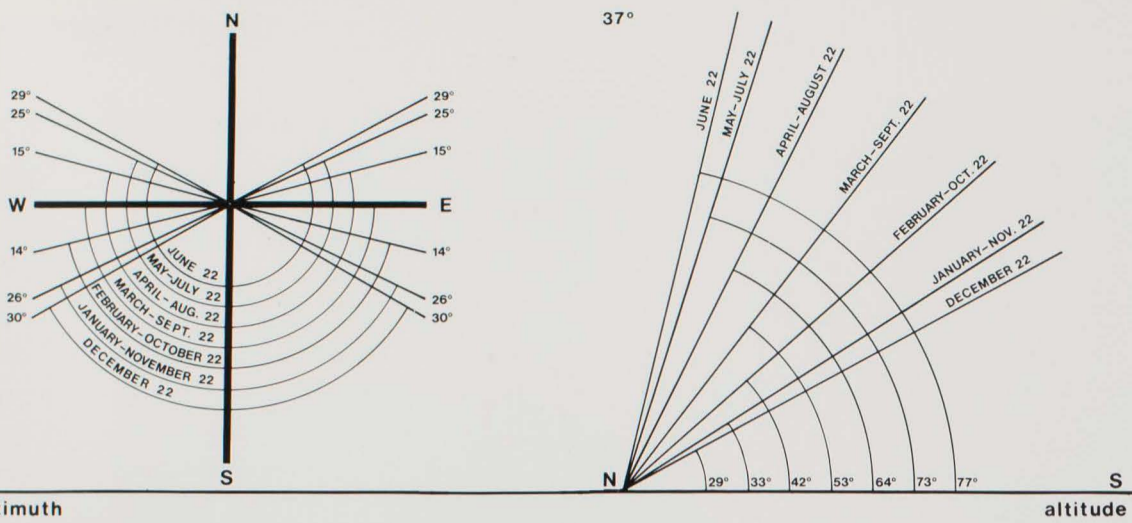

159. Blacksburg - solar angle



160. Eggleston Quadrangle, 1943



161. Eggleston Quadrangle, 1943



162. Proposed storm water detention area



163. Erosion



164. Erosion control strategies

Hurricanes and other tropical disturbances occasionally move as far inland as Blacksburg. Usually such storms only drift close enough to dump heavy rains in the area. Tornadoes are quite rare in Montgomery County. Thunderstorms — accompanied by severe lightning, high wind, and hail — are much more frequent and produce the most severe storm damage.

The Campus Plan map shows the flood plains for Stroubles Creek and its east branch, which converge at the Duck Pond (a siltation and storm water detention pond) and flow eventually to the New River. The upper reaches of the creek's east branch lie in a 500-year flood plain, meaning there is a likelihood of one shallow flood in that area every 500 years. Flooding becomes more likely in areas surrounding the present Continuing Education Center, Eggleston Quadrangle (160 and 161), and downstream from there, increasing to one probable flood in 100 years. This creek currently flows from the eastern edge of campus through an underground conduit which, according to the Master Plan, will be enlarged to eliminate probable flooding.

The 100-year flood plain designation on the main branch of Stroubles Creek also will be eliminated by creating a storm water detention pond (165) at Engineering Park (162) and enlarging the conduit to accommodate flood waters. Increasing the conduit size in both cases will reduce the likelihood of flooding in significant areas of campus and permit building construction in those areas.

Existing campus erosion problems, which are a bi-product of steep campus topography combined with unplanned, heavily-used, pedestrian circulation routes (163), are resolved through a combination of paving, planting, and circulation control strategies (164).



Master Plan

Open Space Use



Open Space Use

Virginia Tech recognizes open space as a valuable resource, and the goal of the Master Plan is to maximize its aesthetic, academic, and functional contribution to the University.

To facilitate planning and design objectives, the Master Plan classifies all exterior space as non-programmed, multipurpose, or varsity athletics space. **Non-programmed** space, which comprises approximately 65 percent of the campus area, is generally considered leftover space in traditional plans. But, in development of Virginia Tech's Master Plan, it is valued as a critical element of the total campus fabric, providing the visual context for campus structures, activities, and circulation (165). A large proportion of this non-programmed space is composed of relatively small increments (166) which, though seemingly insignificant when looked at individually, combine to create the sense of continuity essential to realizing the goal of a visually cohesive campus. The design and siting of elements of construction, circulation, and landscape material reflect an intent to reinforce the integrity of this spatial fabric.

The second largest portion of campus open space is classified as **multipurpose**, and supports informal, unscheduled activities — as well as formal, scheduled activities in dedicated areas. The Drill Field and Pritchard Prairie (167) are examples of large, undedicated, multipurpose areas which support intramural sports and informal recreation and assembly. The primary dedicated open spaces are the golf course (168), south intramural fields, and agricultural land to the south and west.

Nearly 80 percent of the student body participates actively in intramural sports, and the Master Plan provides adequate space for this activity. Because of its position at the center of University activity, the Drill Field is the most visible intramural site. The Duck Pond area is similarly categorized as informal multipurpose recreation space and includes an amphitheater, picnic area, and restrooms. Finally, the academic and residential quadrangles are designated as informal multipurpose recreation areas. Examination of the Master Plan reveals the objective of preserving and enhancing the integrity of these spaces, in spite of the addition of



165. Engineering Park

more than a million square feet of new structures. In particular, the quadrangles (171), as the primary arenas for infill construction, have not only been preserved, but enhanced in their scale and use. In several instances, they are replicated.

The third major open space classification is **varsity athletics**. This area, which includes varsity athletic fields and facilities — Lane Stadium, Cassell Coliseum, and Rector Fieldhouse — is a dedicated zone on the south side of the campus. Development of this zone will add a swimming pavilion, varsity tennis courts, and relocated baseball field and track.

The plan also designates outdoor academic space (171), which identifies specific areas dedicated in support of academic activities, such as horticultural gardening and seismographic studies. Under the Master Plan, the total campus is being promoted as an educational resource. The Duck Pond, for example, offers opportunities for investigation of waterfowl and fresh water ecosystems, as well as surveying, forest species studies, landscape studies, painting, and other activities.

The final open space use designations are primary and secondary nodes, which identify outdoor assembly areas that serve as focal points in the pedestrian circulation system. Cowgill Plaza, Library Plaza (170), and Dietrick Dining Hall Plaza are existing primary nodes that anchor the academic, service, and residential zones of campus, respectively, and support larger, programmed

outdoor activities. Students gather at these plazas, which accommodate large volumes of pedestrian traffic and act as settings for concerts, exhibits, and other activities. The Master Plan calls for the development of five new plazas — four at heavily traveled pedestrian intersections in the campus core and one at a proposed new Continuing Education Center.

Smaller in scale, ten secondary nodes (172) are closely associated with less traveled intersections of major pedestrian walks. Eight of them are located adjacent to primary building entries that abut busy circulation ways. The Master Plan adds eleven more secondary nodes, which include both significant building entries and atria.

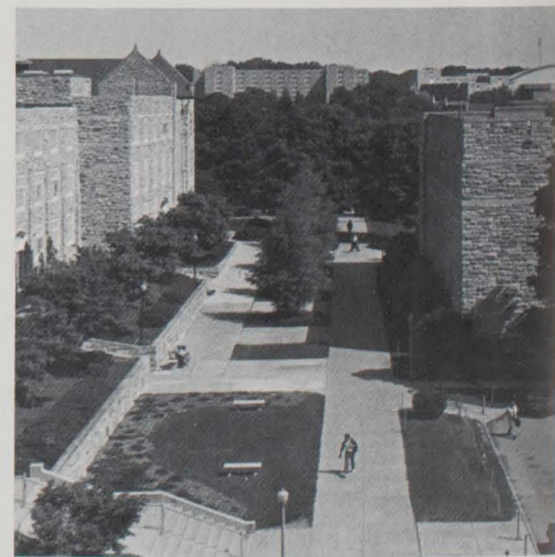

166. Burruss/Pamplin walk

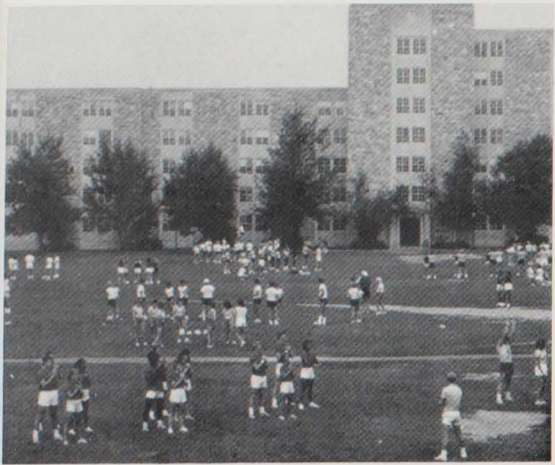

167. Pritchard Prairie



168. Golf course



169. Duck Pond

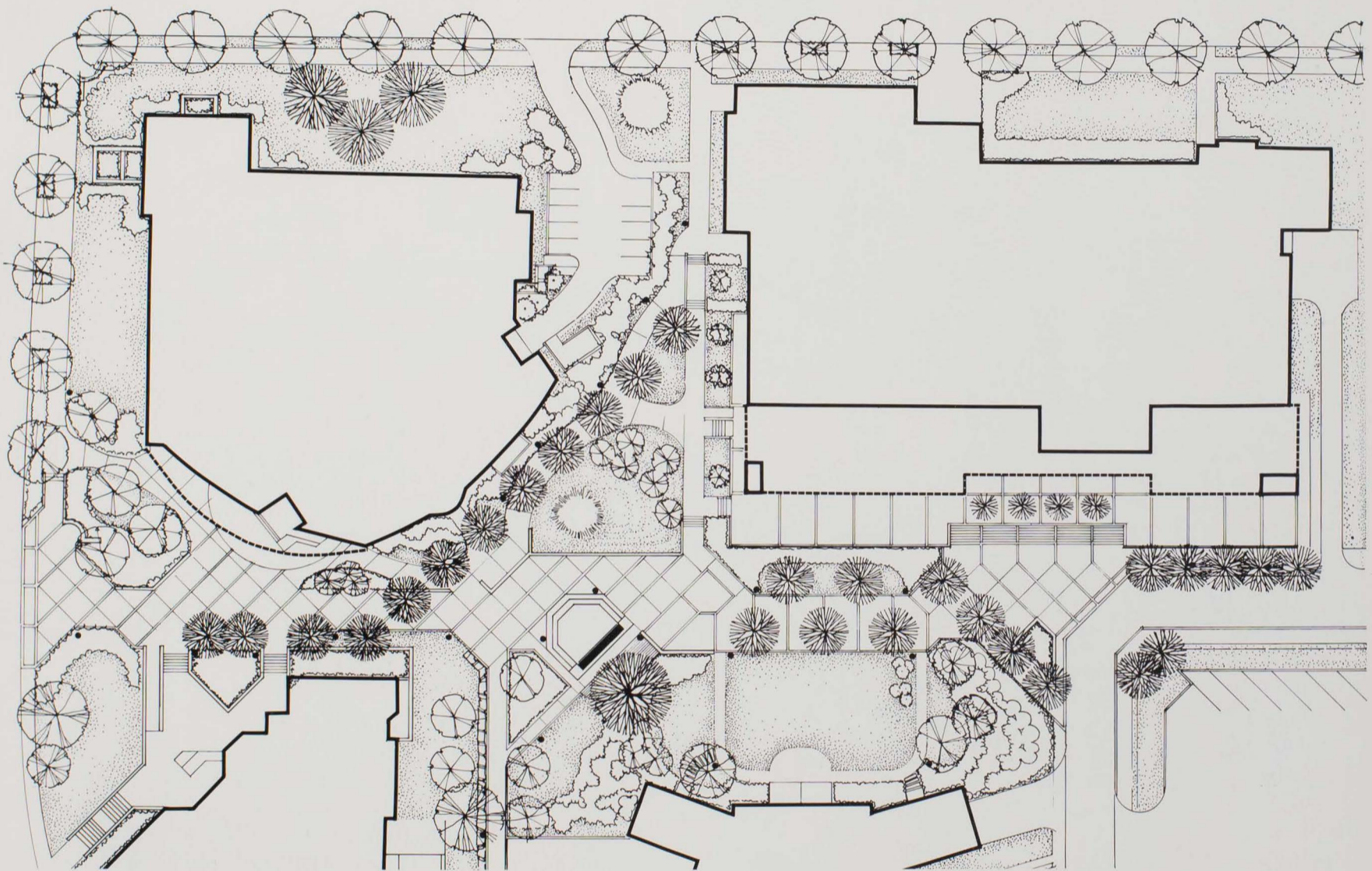

170. Library Plaza



171. Williams Quadrangle

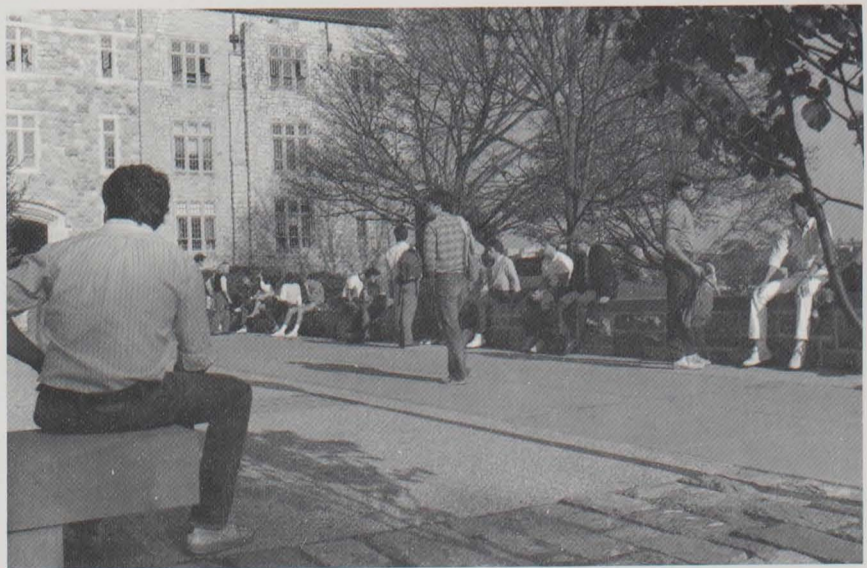

172. Pamplin Plaza





Landscape Development Plan

Large old trees and open lawns contribute to the rural character, historical quality, and natural beauty of the Virginia Tech campus and need to be preserved. But the Master Plan recognizes plant material as having more than an aesthetic value; plants are viewed as integral structural elements of the campus and valuable resources that, through their discreet placement, improve the energy efficiency of buildings, provide visual definition to space, reinforce and clarify circulation patterns, provide shade and windbreak for pedestrians, and control erosion and runoff. Based on these notions, the Master Plan's goal for campus landscape is twofold: To preserve, where appropriate, existing material (181) and to provide new plants supported by management and planting strategies which optimize its impact.

One of the initial tasks in developing this Master Plan was to differentiate between trees to be preserved (180) (chosen because of their size, location and good health) and trees which need to be removed (because of disease or safety problems), small trees which can be easily transplanted, and trees which, due to a variety of environmental incompatibilities, are expendable if in conflict with other campus planning objectives.

Virginia Tech's landscape development plan is based on three areas of concern. First of these is **aesthetics and image**. The use of plant material to reinforce and enhance the University's image is a primary objective of this plan. Mature trees reflect the qualities of permanence and stability appropriate to the University, as well as providing a visual and historical framework. One significant aspect of this framework is informality. While disease has claimed many mature trees, others are declining because of environmental incompatibility. The impact of this loss is most critical where formal planting patterns were adopted (66). Rather than filling these voids with young trees and creating an uneven and visually disconcerting height pattern, the University will plant new trees in a more random manner consistent with early campus tradition (67). By creating an informal campus treescape, the visual and aesthetic impact of the inevitable loss of trees to age or disease will be significantly reduced.



173. Agricultural edge

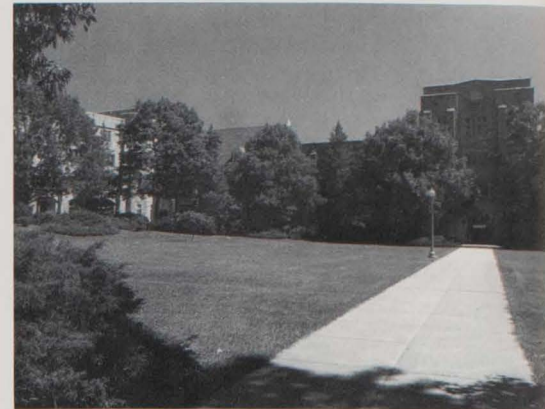

174. Spatial coherence

Another objective of this plan is to develop, as a transition between town and campus, a park-like environment of canopy trees and open lawn, highlighting areas with discreetly-placed shrubbery and flowering trees. This approach also is being employed on the Drill Field perimeter, taking care not to conflict with the intramural and informal activities it supports (175). The plan also acknowledges the importance of the seam between outlying agricultural areas and the main campus (173), treating this area as a transition space. Plant material also functions as a visual buffer between incompatible functions, particularly to screen aesthetically unacceptable elements.

Finally, the use of plants is an important strategy to achieve the Master Plan goal of reinforcing the visual continuity and spatial coherence of the total campus (174). To this end, site-specific schemes, while responding to detailed requirements, must be perceived and developed in terms of the contextual whole.

Function and efficiency is the second area of concern in campus landscape development. This plan mandates the use of plant material

to enhance the energy performance of existing buildings and requires that the design of new increments of construction reflect this objective (81). The opportunities to use trees and shrubs to reduce summer cooling loads and winter heating loads, while well documented, are frequently lost. The incremental infill plan mandates inclusion of these landscape concepts. In addition, given the campus topography, plant material is used to prevent and control erosion and runoff, which in turn preserves aesthetics and reduces maintenance.

Plant materials are also used to enhance the visual clarity of campus circulation routes, as well as provide shade and wind protection for pedestrian ways (179) and outdoor plazas (177) and courts. Foundation planting (178), which has been used at Virginia Tech and is a common practice elsewhere, is rejected in this plan because of fire safety issues. This type of planting provides fuel adjacent to windows and impedes fire equipment access and suppression efforts in emergency situations (149).

The third landscape issue is **plant management and maintenance**. A primary objective

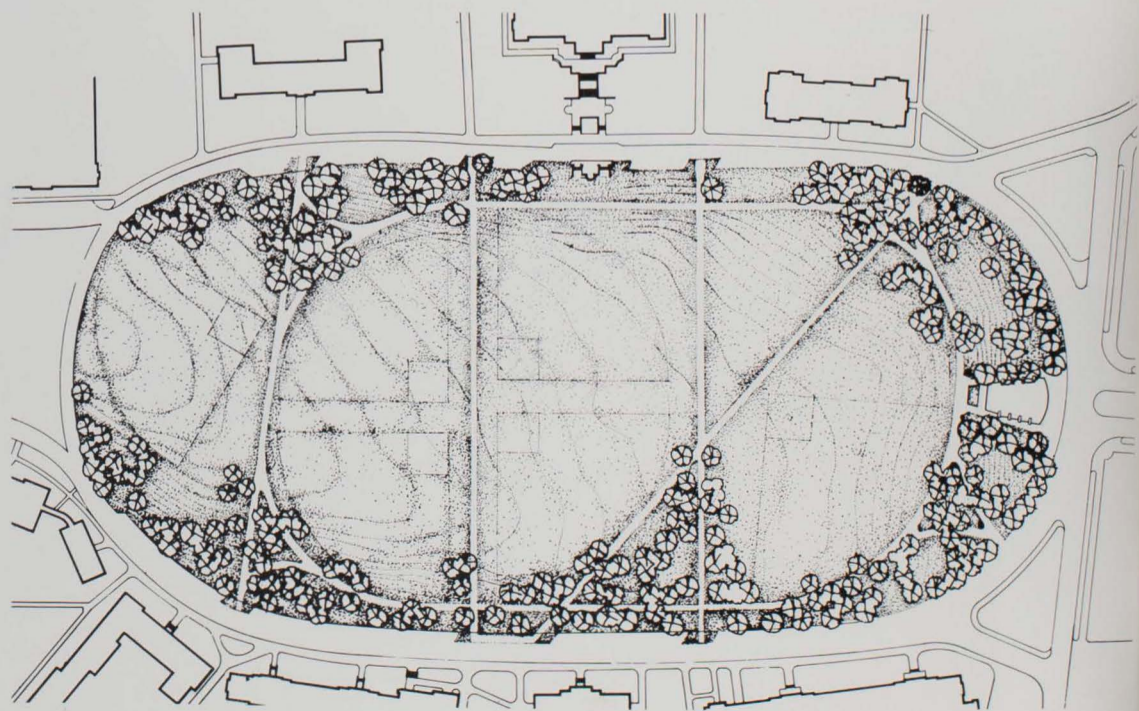

175. Drill Field planting plan

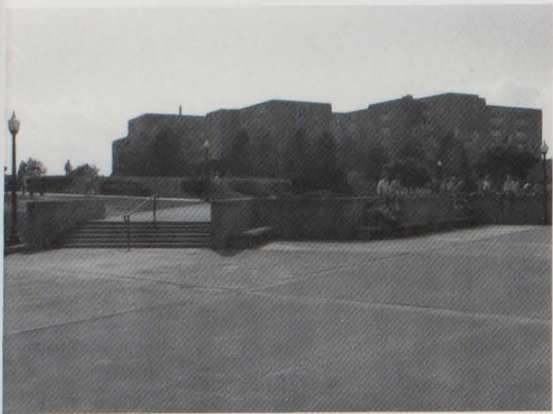

176. Dietrick Plaza

of this Master Plan is to ensure the selection of plant material which is compatible with both the natural environment of Southwest Virginia and the complexities and demands of an institutional landscape. To this end, an approved plant material list — comprised primarily of hearty, low-maintenance, native species — is provided in an appendix to this document.

Exotic or specimen trees are localized into collections where they can receive adequate attention. Given the large campus size, this approach not only reduces maintenance costs, but increases the impact of this material. The placement of trees and shrubs reflects an attempt to accommodate large riding mowers, thus reducing the need for costly hand labor. The one high-maintenance exception to the overall strategy is inclusion of annual flower beds located at the campus entries, along the Mall and in the Library Plaza, which is a major outdoor activity area. In addition, this plan establishes a small holding nursery to ease new plants' transition to Blacksburg and store material transplanted from campus, including plants displaced by new construction.



180.

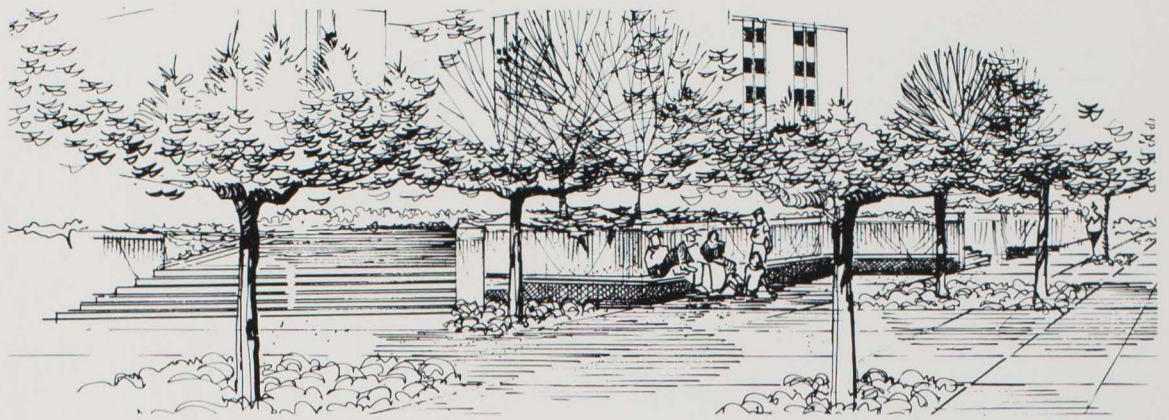

177. Proposed Dietrick Plaza planting



178. Typical foundation planting

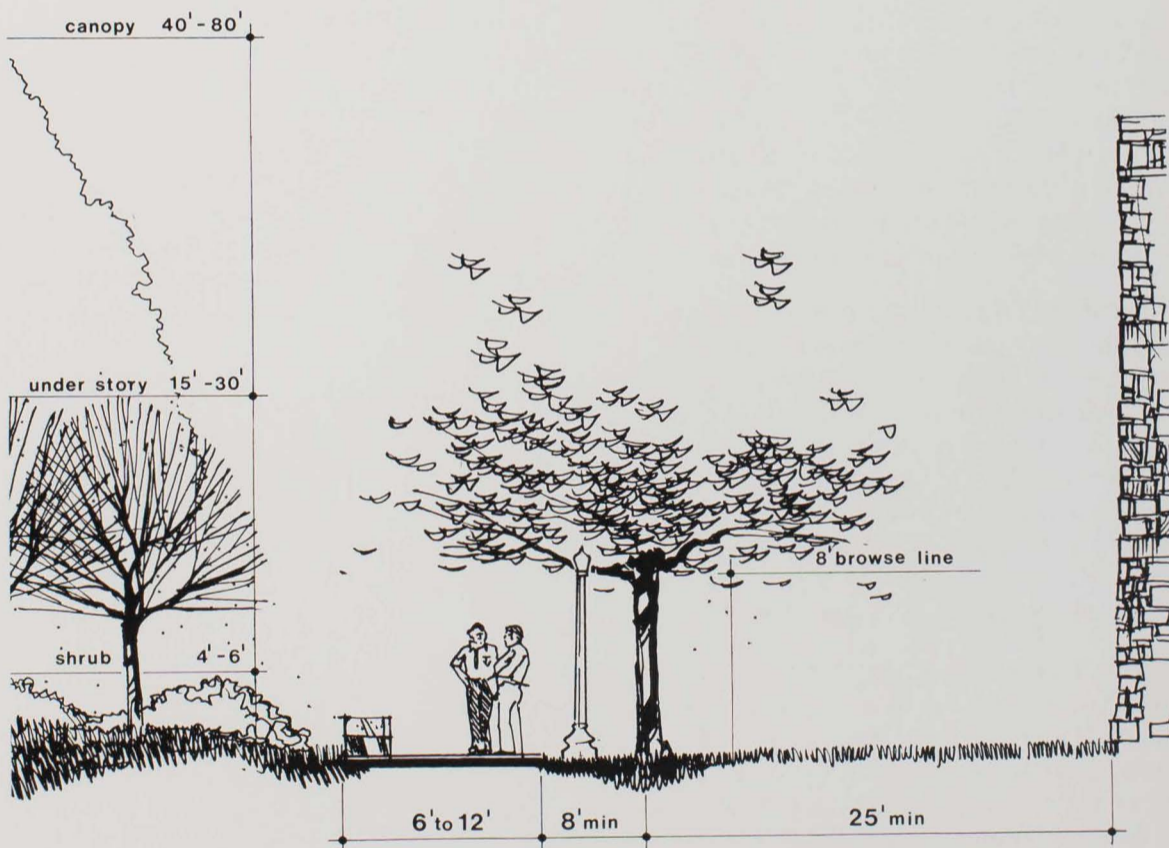

179. User-related planting



181.

Infrastructure

The intent of this Master Plan is to ensure a safe, dependable, efficient, and cost-effective network of services which are sized and located to accommodate the present and future needs of the campus.

Infrastructure System

The University has developed, through a sizable investment of financial and management resources, a complement of utilities to economically and effectively meet campus building needs. Parts of the physical network have been developed cooperatively with other public institutions and private utility companies to each participant's benefit. Implementation of this Master Plan will increase the benefits to the University and offer comfort and convenience to campus users without the large investments formerly required to extend utilities to new construction sites at the campus periphery. By tapping into the central network and eliminating the need for long extensions of utility systems, incremental infill construction will reduce infrastructure costs associated with new construction and the upgrading of existing campus buildings.

Sanitary waste disposal for the town and University is provided by the Blacksburg/VPI Sanitation Authority. Water for the county, town, and University is provided by the Blacksburg-Christiansburg and VPI Water Authority. The University operates an electric service for a portion of the town and all of the campus power needs which taps the

- Steam Systems**
 - Low Pressure
 - High Pressure
 - Condensate
- Hot Water Systems**
 - Supply
 - Return
- Communication Systems**
 - Telephone
 - Computer
 - Television
- Compressed Air System**

185. Typical steam tunnel section

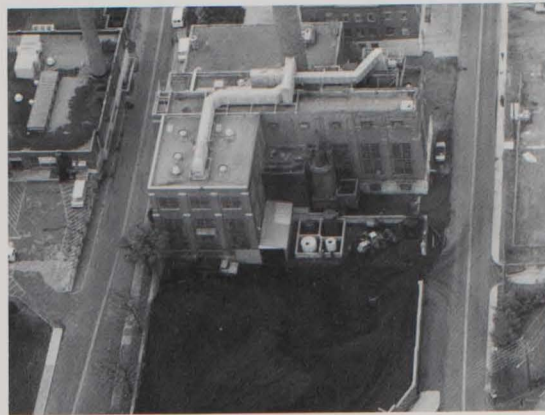

182. Power plant

Appalachian Power Company network and the University's generating capabilities. Natural gas is supplied by Tennessee-Virginia Energy Corporation.

These electric, water, and gas networks support the economic production of additional resources for campus buildings. Steam, hot water, chilled water, and compressed air are produced at the University-operated central plant on Barger Street and delivered to campus buildings through an integrated network of tunnels and buried lines. This complement of utilities has supported the University's functional needs for many years, expanding when economical and effective. It is the University's intent to continue this practice.

A major premise of the infill concept is the realization of a solar contribution to new building increments which will reduce the demand on centrally supplied utilities. Key to this concept is the construction of solar atria between existing and new buildings. Atrium spaces will function as solar collectors, producing heat for functional use and conserving energy by receiving the heat loss from existing buildings. The University also is committed to using other renewable energy sources when their application is economical, effective, and reliable.

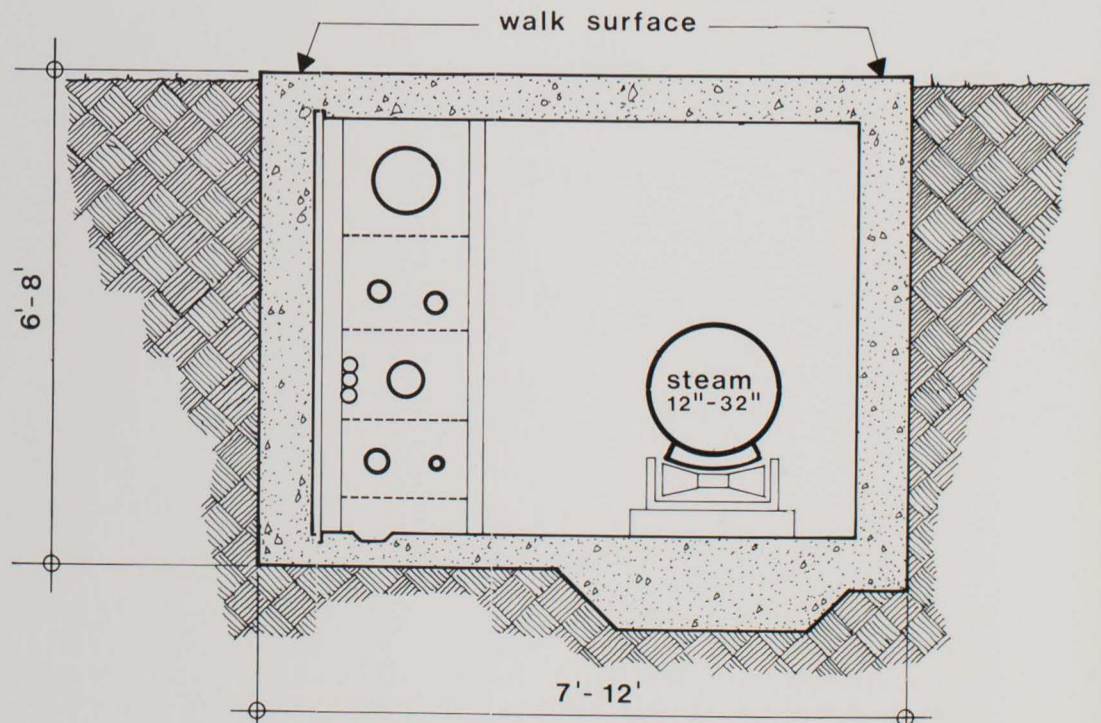

183. Coal storage

Integral to the application of alternative energy sources is accurate control and assessment of energy consumption in buildings. The University utilizes the MCC-Powers Systems 600 central computerized system to monitor and control the operation of individual building mechanical systems and central plant equipment performance. Fire and security management are not included in this system.

(Note: The following discussion of individual infrastructure systems is keyed to a series of detailed maps published in respective



184. Tunnel walkway



186.

order immediately following this section of text.)

Steam. The University central power plant produces steam for heating and process purposes. This requires initial treatment of incoming water from the local water authority. Coal-, gas-, and oil-fired boilers produce steam, which is delivered at 15 psi at 230 degrees F. for heating use and 90 psi at 330 degrees F. for process purposes. Condensate from steam distribution and use is returned to the plant for re-use. Steam is distributed to the core campus via a walk-in steam tunnel system and to outlying areas by lines directly buried or in smaller tunnels.

Chilled water. Chilled water produced at the central refrigeration plant is delivered to the campus at 42 degrees F. with expectation of a three-degree change in temperature. The plant has a 1,200-ton capacity and delivers chilled water only during the cooling season, which lasts from April to September. A planned expansion of the system will increase its efficiency and provide some cooling during the off-season. The Master Plan strategy is to integrate existing chillers in excess of 100 tons into the central distribution system and satellite chillers included in new increments of construction to supplement the total system capacity. These steps will achieve greater operating efficiency, reduce distribution line loss, and expand the central plant, as needed.

Storm drainage. Development in the town of Blacksburg directly affects storm drainage through the Virginia Tech campus via Stroubles Creek, and this growth is taken into account as the University assesses its drainage system capacity. Existing storm drainage on campus is adequate to accommodate normal runoff, but the Master Plan adds an additional detention/retention pond and underground conduit to supplement the existing system and reduce the potential for damage due to insufficient storm water management. In addition, infill construction may require some supplementing of lateral lines feeding into storm water mains.

Sanitary sewer. Sanitary sewer mains running through campus are owned and maintained by the Blacksburg-VPI Sanitation Authority; lateral lines belong to Virginia Tech. Major recommendations resulting from a detailed inflow/infiltration study have



187.

been implemented and secondary actions are performed as individual circumstances permit. Incremental infill construction also may require additional lateral lines in the sanitary sewer system.

Domestic hot water. Domestic hot water, produced at the central power plant, is heated by low-pressure steam to 130 degrees and delivered to campus facilities at 75-80 psi. The distribution system is organized into two separate loops, each equipped with recirculating pumps. A 15-degree to 25-degree F. temperature drop is expected at the extremities of the distribution system. The domestic hot water system has adequate capacity to serve the existing load, which includes washrooms, custodial facilities, and dining operations throughout campus. The distribution system uses the existing tunnel network, when practicable.

A number of buildings on the campus perimeter have their own domestic hot water production facilities. This approach began because of the poor economics of centrally producing and distributing hot water. These satellite production facilities use 15 psi steam exchange units. Since low pressure steam is not produced in the summer, these units are equipped with pressure reducing valve assemblies to accept 90 psi steam during the summer months. Exemplary installations of local domestic hot water production plants are located in the Veterinary Medicine School and the Animal Sciences Building.

Electrical. The VPI Electric Service supplies power to the campus and part of Blacksburg. Approximately 75% of the electricity is purchased through a wholesale agreement with Appalachian Power Company; the remainder is produced by a steam turbine generator at the University's central power plant and is available only during the cold months, when steam is being produced to heat campus buildings.

Electric power enters the University network at the central power plant. The APCO substation at VPI was designed to minimize interruption of service, with two separate transmission lines feeding the University substation. Loss of either the transmission line or the power transformer at the VPI substation will not interrupt service.

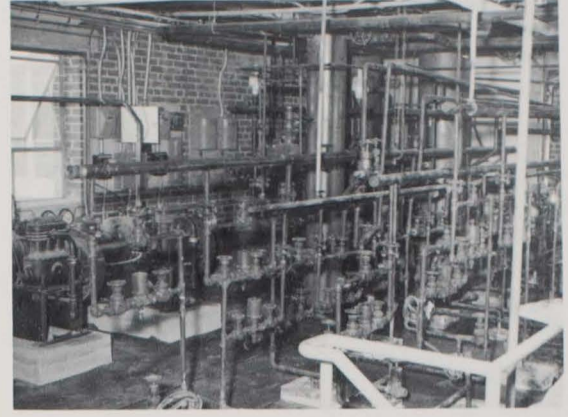

188.

Telephone and Computer Cable Networks. To provide efficient, reliable, and economical support to data, voice, and some video information systems on campus, Virginia Tech has placed these separate communications technologies under the supervision of a single office, Communications Network Services. This office conducts the planning, engineering, administration, maintenance, and software development for these existing systems and plans a complete integration of them into one network. Cables in existing buildings are being upgraded during renovations, whenever feasible, to accommodate increasing and changing demands. Virginia Tech is evaluating the feasibility of developing a telephone system, as well as providing sophisticated data and video connections to within a few feet of all work stations, including dorm rooms.













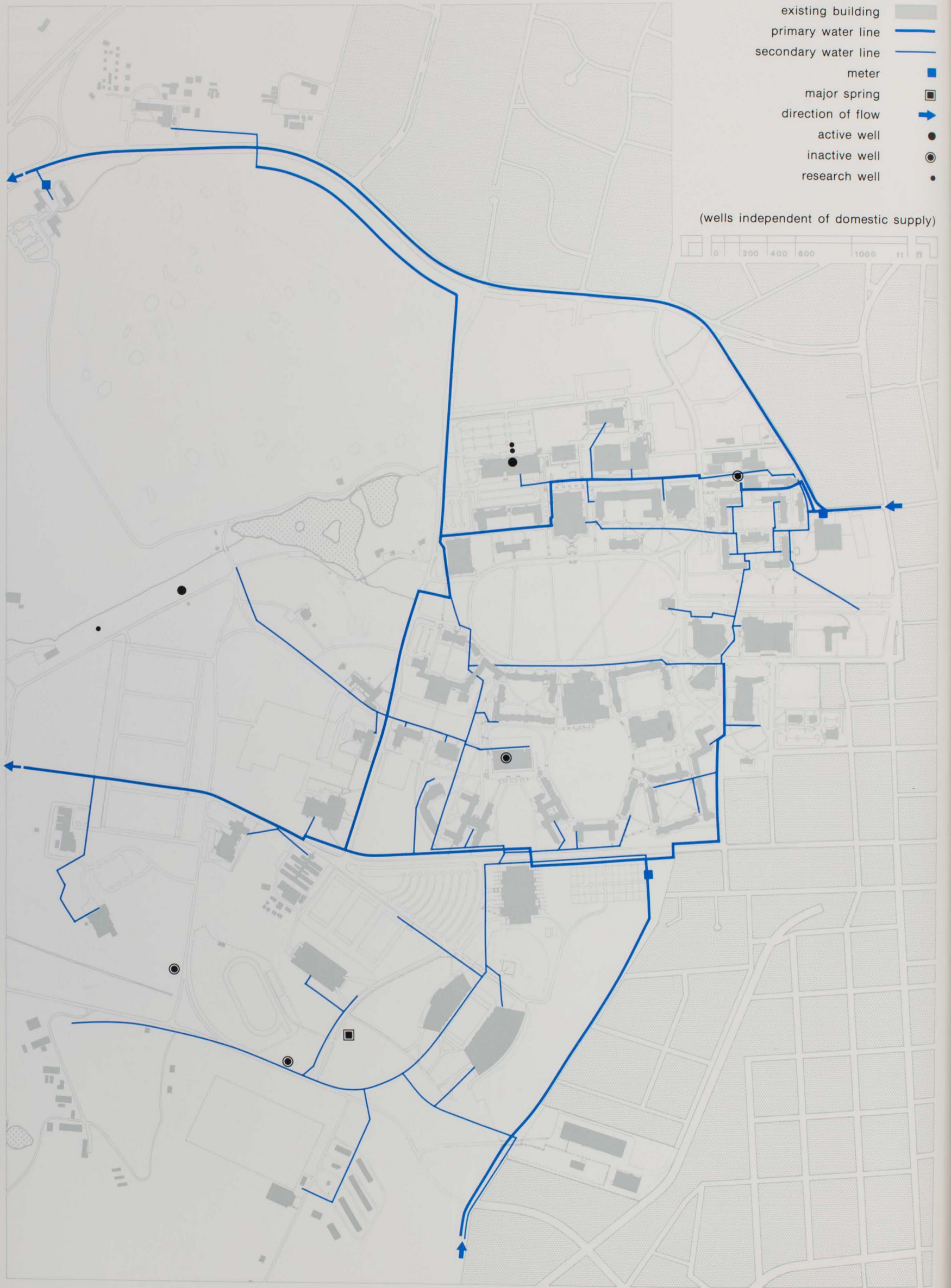















Implementation

Realizing that a campus responds to constantly changing needs, planning for the campus future with a complex matrix of goals demands a new and distinctive process of implementation.

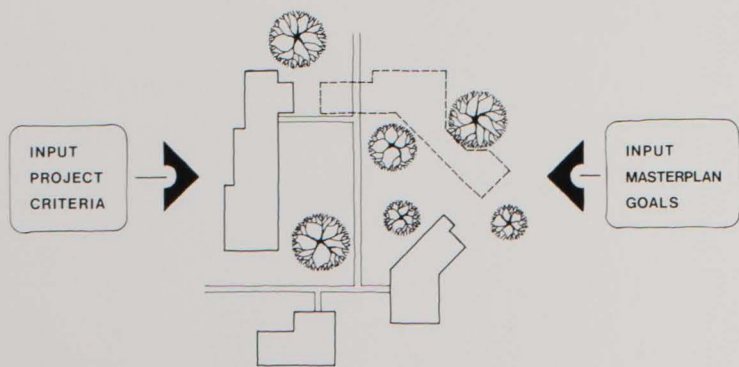

189. Responsive planning

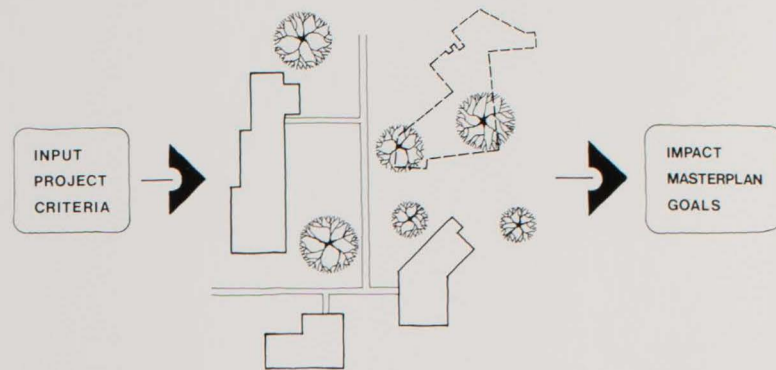

190. Reactive planning

Implementation Process

The intent of this Master Plan is not to provide a catalog of solutions, but rather to present a matrix of generic goals and objectives to ensure a campus future reflective of its historic past and present. Key to this future are the previously articulated concepts of preservation, integration, regeneration, and adaptation. In addition to being performance-oriented, rather than solution-oriented, this plan requires an implementation process that is integrative (191) rather than additive (192). This process mandates the definition, development, and evaluation of each addition or change to the campus in terms of an integrated, interrelated whole. With this philosophy, the traditional synthesis of solution, in response to a set of site- and function-specific needs and criteria, is considered at best a starting point. Ad hoc solutions are its antithesis.

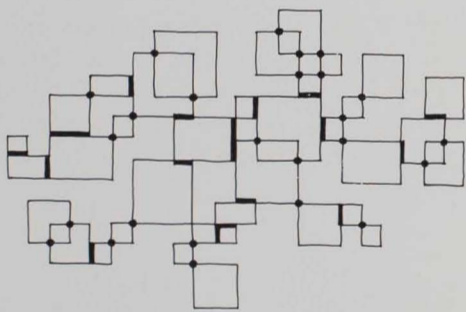

191. Integrative process

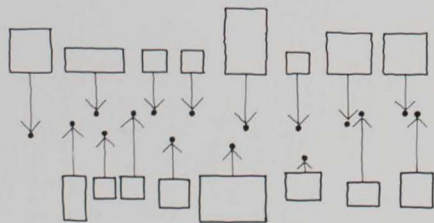

192. Additive process

Two general implementation strategies evolved concurrent with development of the Master Plan and this **integrative process**. The first is to view every change to the campus environment as an opportunity to enhance its functional, aesthetic, and experiential qualities. This simple, yet effective, strategy requires that the solution to each individual need — whether it is adding an increment of construction, renovating an interior space, planting landscape material, or modifying a campus walkway — reflects a

response not only to specific criteria but to the more comprehensive Master Plan goals (189). Key to following this strategy is asking, "HOW can this action be manipulated to impact on A, B, C and D?" rather than the conventional question (190), "On WHAT will this action impact?"

The second strategy is to redefine constraints as opportunities. To a large extent, the concept of incremental infill construction stemmed from this process. Funding constraints which prohibited construction of large, functionally self-supporting, independent buildings in conformity with the previous Master Plan, together with severe space deficits, resulted in an untenable situation. The proposed response, a traditional one in such situations, was construction of inexpensive "temporary" structures. But the present determination is to avoid "quick fix" solutions, because of the history of longevity that "temporary" structures enjoy, as well as the deleterious impact on the University environment that can be predicted. The concept of incremental infill construction evolved as an alternative that is responsive both in terms of immediate constraints and long-term goals.

One significant example of constraint treated as opportunity is the cost and availability of energy resources. Response to this constraint is resulting not only in more energy-efficient buildings, but in new and exciting space which contributes greatly to the overall quality of Virginia Tech's environment. As well, the environmental and maintenance constraints related to scattered use of exotic and specimen plants on campus resulted in consolidation of them in areas that enhance their visibility and contribution to the campus aesthetic.

Similarly, constraints on the availability of space have resulted in significant changes to

the "business as usual" approach to the assignment, maintenance, and management of space, resulting in significantly improved utilization.

Included among these changes are development of multi-use and shared use of space; scheduling adjustments; modification of teaching and research methods; consolidation of activities; elimination of marginal functions and programs; introduction of office landscape concepts and high-tech information systems; enhancement of building efficiency through regeneration and renovation; reassignment to improve space-function compatibility; and provision of incentives and/or disincentives to holders of marginally used space. Use of many of these alternatives has netted the University more than 40,000 net square feet of new academic space in the past two years.

Many of these alternatives emerged from a "space opportunities workshop" sponsored as part of the Master Plan development. At the two-day workshop, 60 members of the University community (including students, staff, administrators, and faculty) gathered off campus and focused their attention on methods for generating new space (193, 194, and 195). Except for a prohibition on discussions of space "problems," their brainstorming was unrestricted.

A critical element of this integrative planning process deals with the specific issue of establishing new construction priorities which reflect the true space needs of the University, and not a preconceived notion of them. To this end, this process incorporates six distinct steps: **Qualify, modify, identify, evaluate, prioritize, and initiate** (196).

The first, **qualification**, requires that the specific space needs of each major University component be assessed by four different



193.



194.

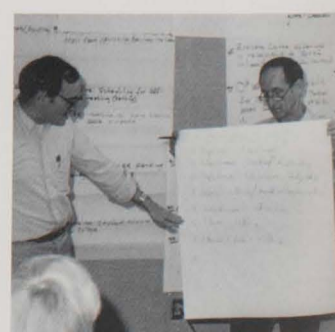

195.

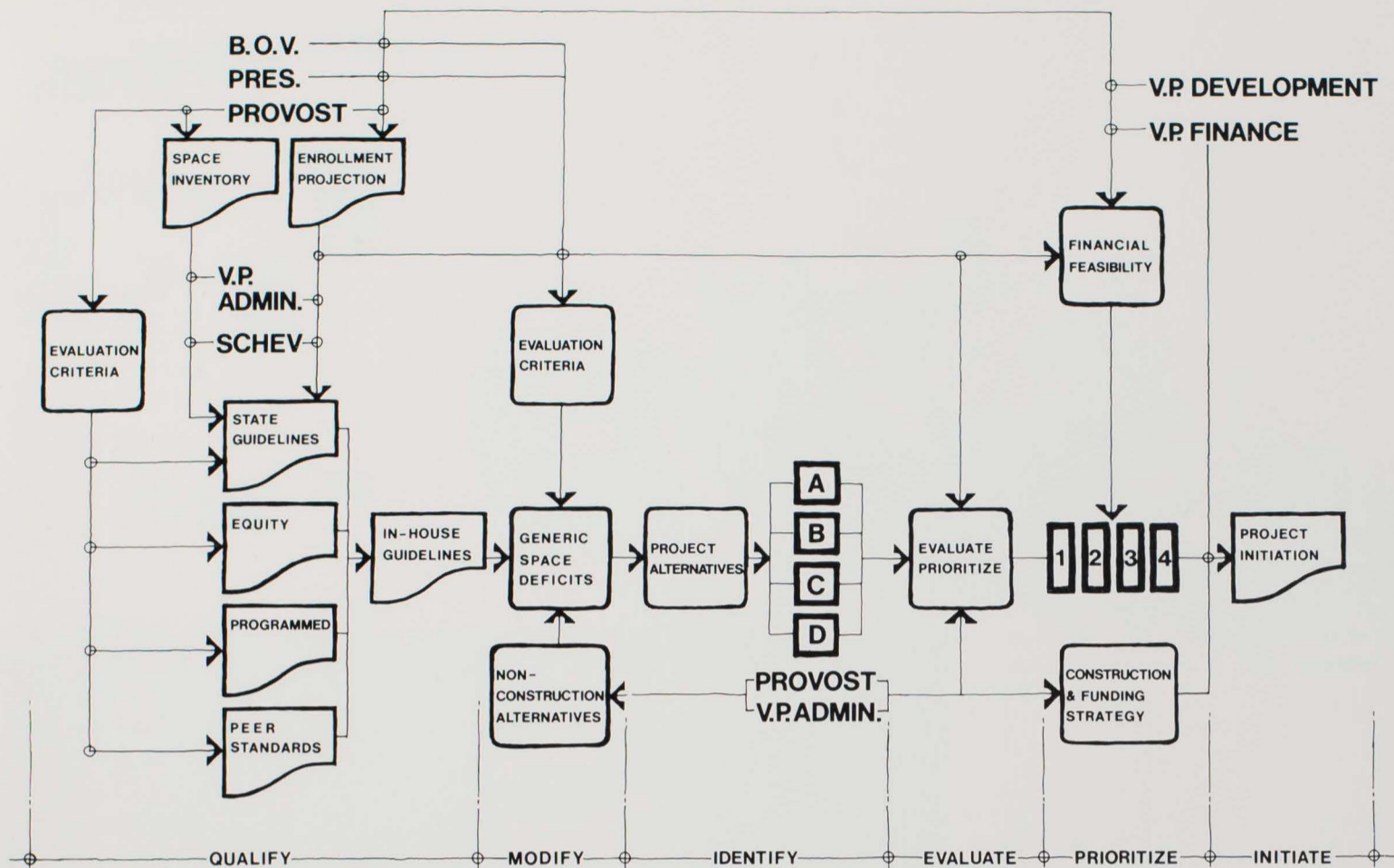

196. Capital Outlay planning process

methods. The first, by **state guideline**, is a calculation based on standards established by the State Council of Higher Education in Virginia (SCHEV). The second method, **equity**, is based on a calculation of the amount of space assigned as a percentage of the total space available. For example, if all existing space was reassigned through an equitable formula, would a given college or department receive more or less space than it presently occupies? The third is by conventional **programming** — that is, calculating the space required to accommodate each specific function. The last method is to determine need in terms of accreditation and/or **peer group standards**. The objective of this strategy is to evolve an in-house space guideline which reflects relative space needs.

The second step, **modification**, includes introducing the concepts of generic and university space. Defining and evaluating space deficits in terms of the University's total inventory of generic space, prioritized and recorded by college or department, results in expanded opportunities to optimize its use (197). Historically, the needs of a given college are articulated exclusively in terms of the adequacy of the space assigned to it. This approach necessarily results in the construction of new facilities including space that, in the University context, frequently represents a low priority. As seen in the "space and project priorities" diagram, this generic process proposes aggregation of high priority needs into capital projects, thus ensuring a greater impact from each construction dollar. Integral to the employment of this generic classification and prioritization of space is the reduction of space needs through non-construction alternatives including, among

others, scheduling consolidation, interior planning, re-assignment, and use modification.

Step three is to develop incremental construction alternatives and **identify** the increments which respond most effectively to the highest priority space needs yet to be fulfilled.

Step four is to **evaluate** each of these increments in terms of specific functional requirements, operational implications, location criteria, financial feasibility, and potential for implementing the University's larger

planning goals.

Step five is to **prioritize** them according to their relative impact on the overall mission of the University in terms of program implications, funding opportunities, and the time frame for their implementation.

Step six is **initiation** of the Capital Outlay projects review and approval process. While this diagram and its narrative description imply a lineal process, in reality it is cyclical, requiring many iterations which reflect the integral nature of facility, program, and fiscal planning.

		COLLEGE PROGRAM NEED							
		I	II	III	IV	V	VI	VII	VIII
GENERIC SPACE	Classrooms	2	2	1		3	3	4	1
			4	3			1		4
		2	4	3	3	3	3	1	3
	Teaching Labs	4	1	2	1		1	3	1
			2	1	1	1	3	4	2
	Research Labs	1		2	3	4	3		1
			1	1	2	4	1	4	
	Offices	2	2	3	1	4	2		1
		1	4	3	4		2	2	
		1	1	3	3		3	2	4
	Other	4		4	4		3		
			4	1	1	3	4		
3		2	4	1	1	2	1	4	
3		4	4	4	1	2		4	
	3	4		3	4	4			

		CONVENTIONAL (College Space)			
		1	1	1	1
		2	2		
		3	3	3	3
		4	4		

		INFILL (University Space)			
		1	1	1	
		1	2	1	
		2	1		
	Increment A	1	1	2	
		1	1	1	
		1			
	Increment B	1	1	1	
		1	1	1	
		2	2		
	Increment C	1	1	1	
		1	2	2	
		2	1		
	Increment D	1	1	1	

197. Space and project prioritization

Development of Project Alternatives

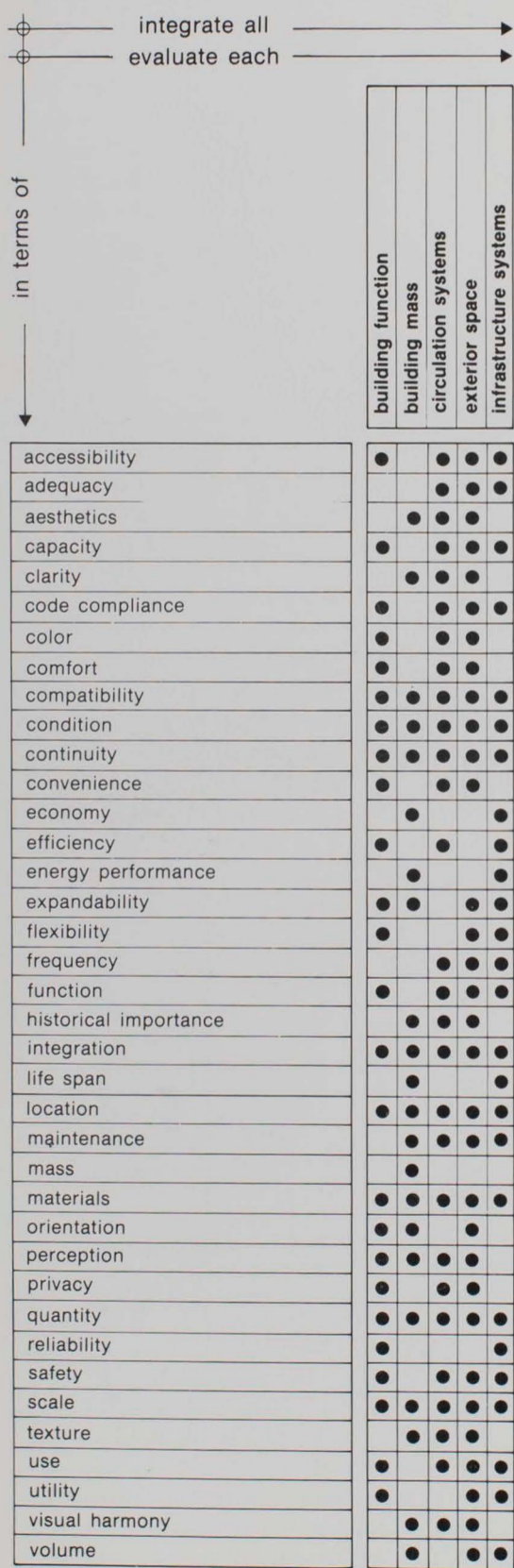

199. Evaluation matrix

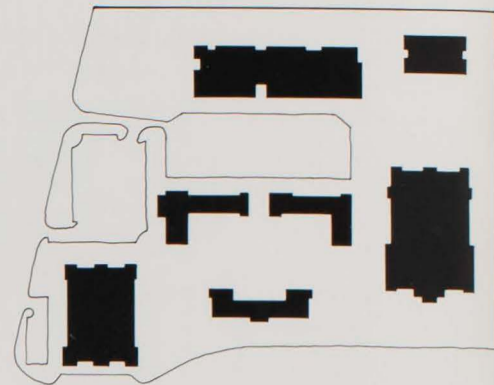

198. Existing Business/Chemistry site:

- A- Auditorium component
- B- Business components
- C- Chemistry components

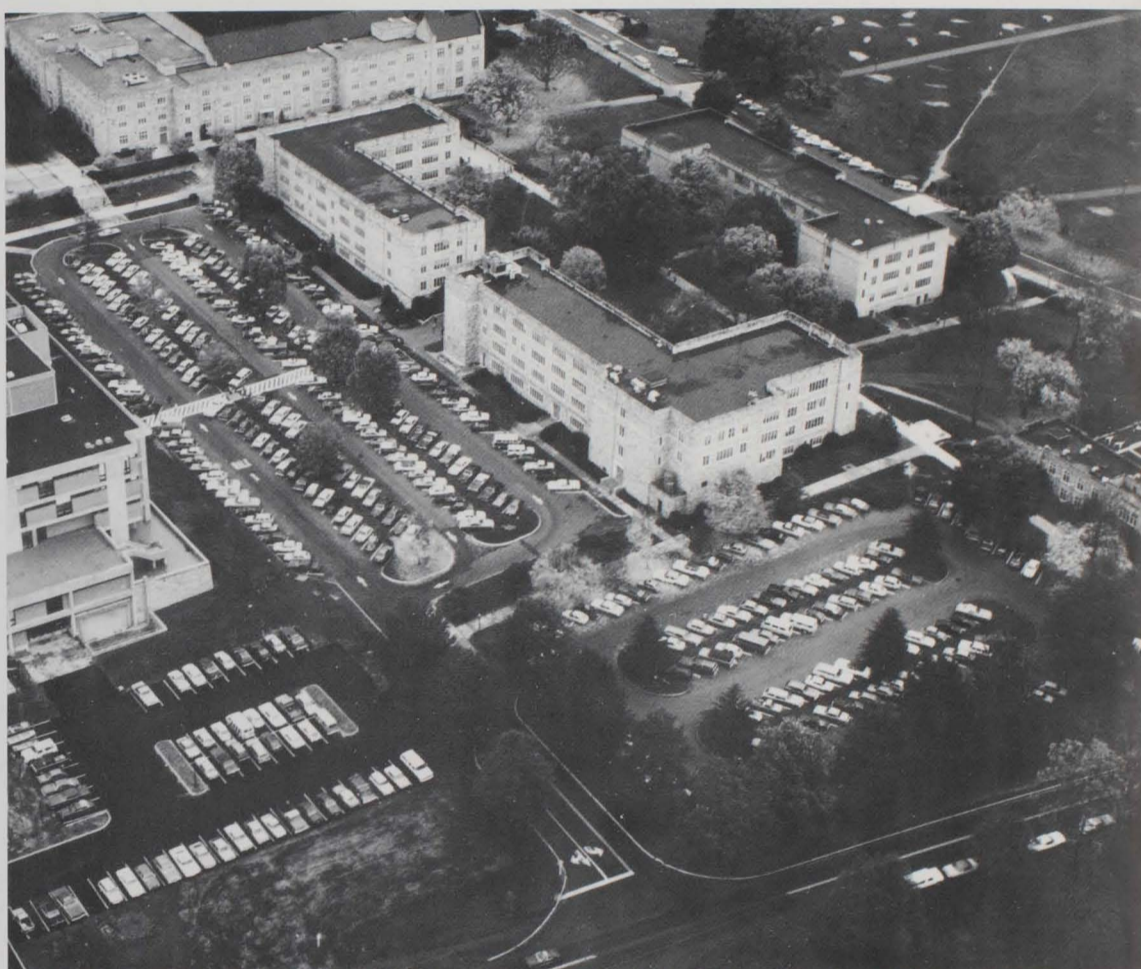

200. Business/Chemistry site

In developing increments of construction, each quadrant or discrete zone on campus was studied to determine its capacity to accommodate additional structures in a way which would preserve, enhance, and/or complement the existing building mass, building function, exterior space, and circulation and infrastructure systems. Concurrent with this integrative analysis was an attempt to develop design alternatives based on the optimization of separate-but-equal, discrete planning objectives. Examined, for example, were optimal solutions in terms of energy, preservation of open space, provision of atrium space, etc. Each of these component plans was then measured against a comprehensive, but not exclusive, evaluation matrix (199). This strategy of single-objective optimization led to the development of, in one case, a design which resulted in the most

flexible, convenient, and safe circulation systems. Another resulted in the optimization of the building mass in terms of scale, compatibility, expandability, energy implications, and so on. The objective of this strategy was to explore the broadest range of opportunities and integrate them into a responsive and responsible whole.

As additional site- and program-specific criteria were identified, a number of viable design alternatives evolved. In the case of the Business/Chemistry infill project, located adjacent to the Williams Quadrangle (200), five schemes compatible with the program needs and general Master Plan goals emerged. These schemes were evaluated relative to each other, and scheme four (204) was selected. This scheme became a starting point for the architectural consultants selected to design the increments (87).

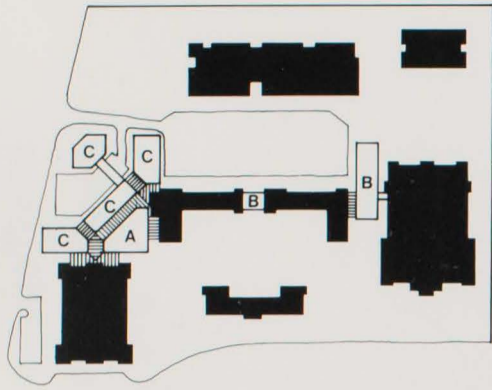

201. Scheme 1

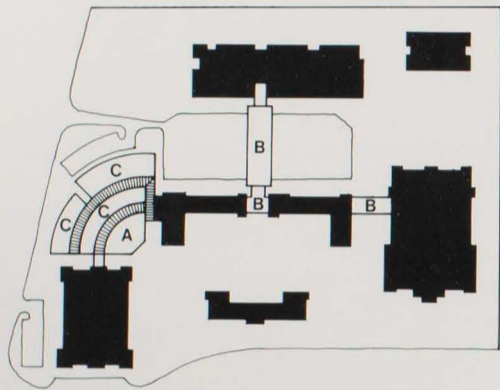

202. Scheme 2

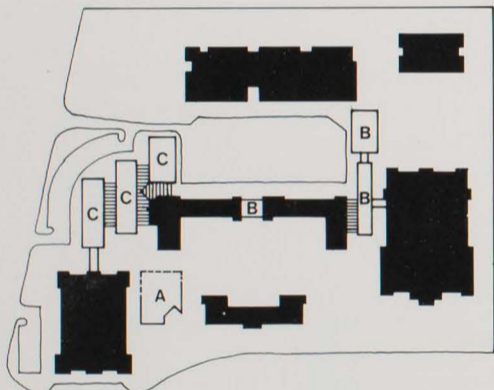

203. Scheme 3

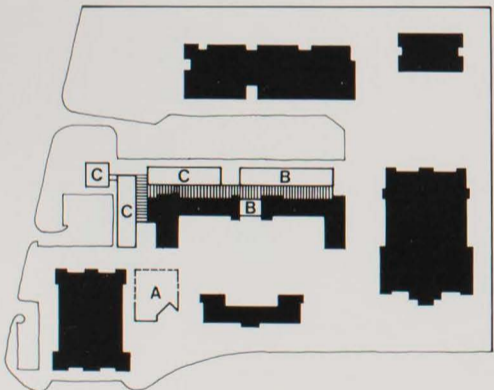

204. Scheme 4

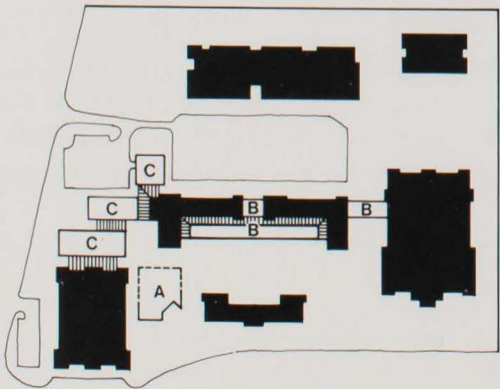

205. Scheme 5

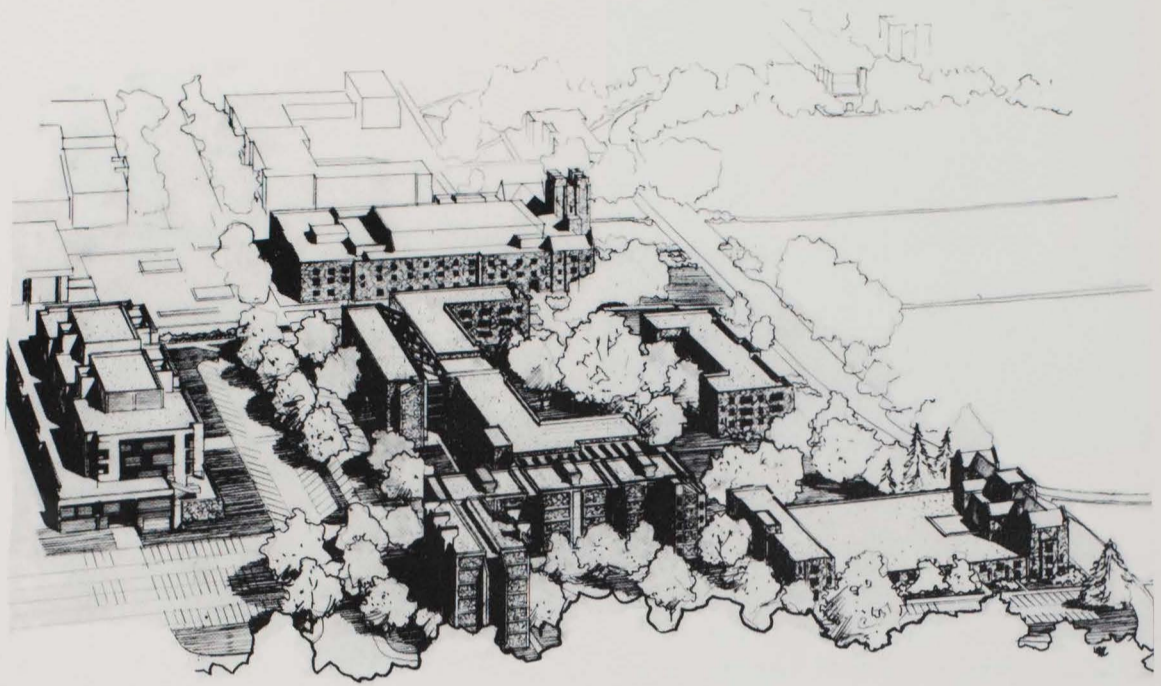

206. Phase one development

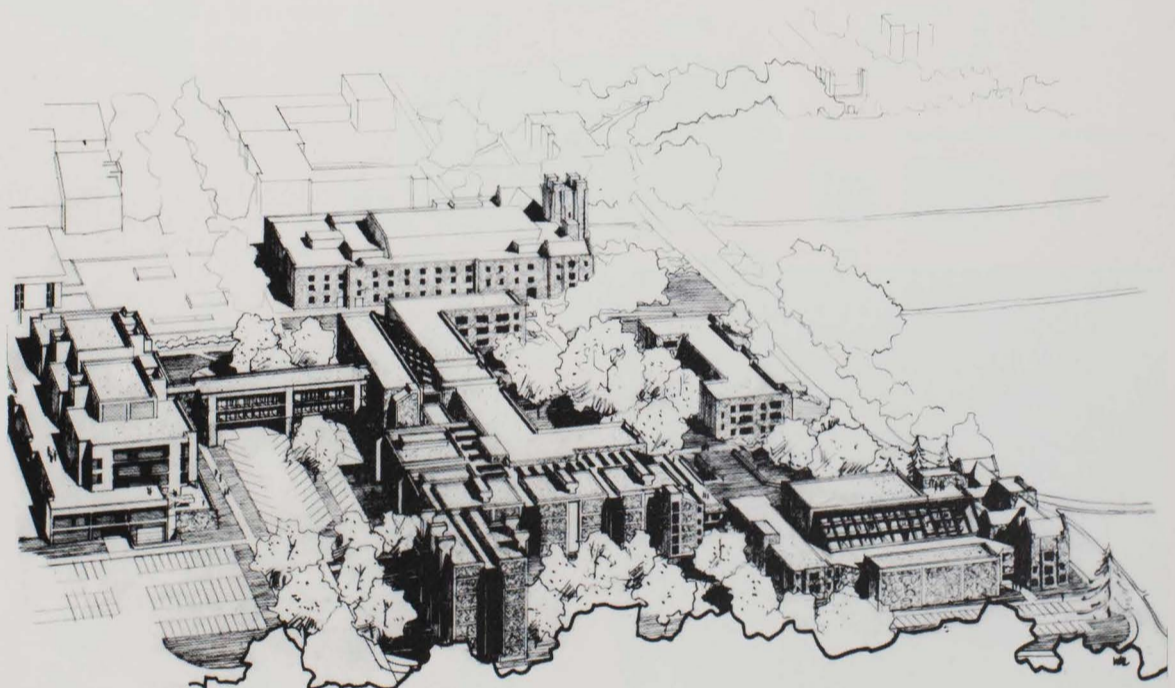

207. Long-range development plan

Each scheme was evaluated in terms of:

- response to programmatic requirements.
- functional integration with existing buildings.
- provision of atria spaces as an energy, circulation, and functional enhancement.
- compatibility with existing infrastructure.
- flexibility to respond to alternatives in construction staging.
- impact on existing functions during construction.
- accessibility to emergency vehicles.
- response to service requirements.
- impact on existing parking.
- enhancement and reinforcement of through circulation ways.
- potential for incorporating passive energy concepts.
- impact on the energy performance of the existing buildings.
- mass relationship to other quad buildings.
- impact on views to and from the Drill Field.
- impact on the spatial and aesthetic integrity of the quadrangle.
- effectiveness in providing an architectural transition between Pamplin and Robeson Halls to the south and Derring Hall to the north.
- enhancement of the overall visual integrity of the campus, particularly as one enters from the northwest.
- impact on existing trees.

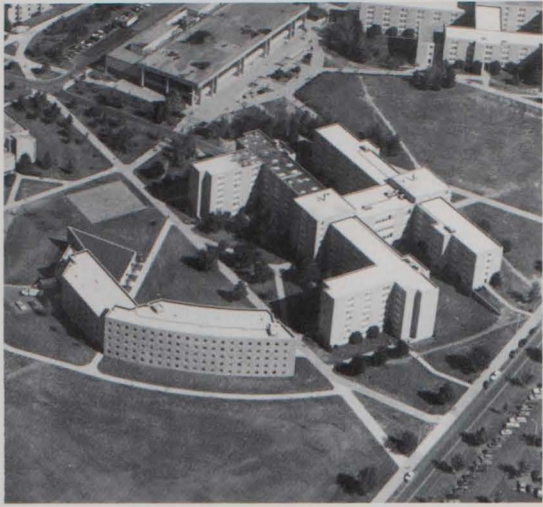

208.

Examples of two recent projects which, while initiated prior to the development of the Master Plan, were modified and completed to reflect the goals of the plan are an undergraduate dormitory and the College of Veterinary Medicine.

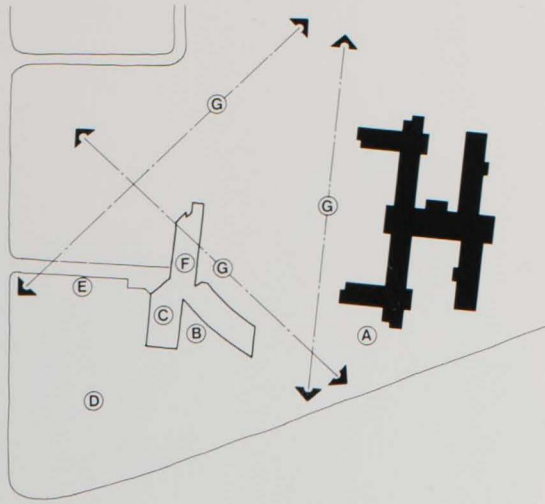

209.

Undergraduate Dormitory
Original Site and Design

(characteristics)

- A - unrelated to existing dormitory complex
- B - locates programmed outdoor area adjacent to road traffic and public circulation
- C - dining hall view is to road
- D - divides site in two
- E - adds new service road and curb cut
- F - designed as all-white limestone unrelated to existing campus aesthetic
- G - unrelated to existing pedestrian circulation

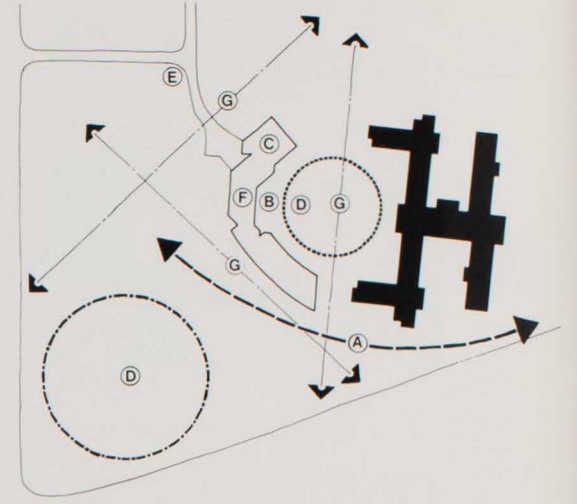

210.

Resited and Designed to Respond to Master Plan Goals

(characteristics)

- A - provides continuation of architectural edge and visually terminates dormitory complex
- B - locates programmed outdoor area in quad
- C - dining hall view is to quad
- D - creates new residential quad
- E - preserves corner lot for informal recreation
- F - utilizes existing service road
- G - exterior stone to match existing residential structures
- H - reinforces and enhances existing pedestrian circulation



211.

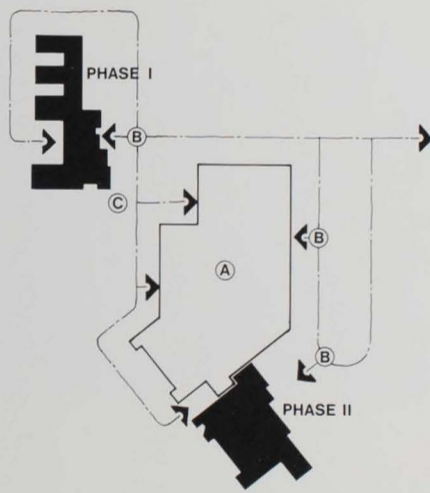

212.

College of Veterinary Medicine
Original Master Plan

(characteristics)

- A - Phase III designed for construction as a single element
- B - complex includes multiple entries complicating control
- C - functions separated by both vehicular circulation and construction activities

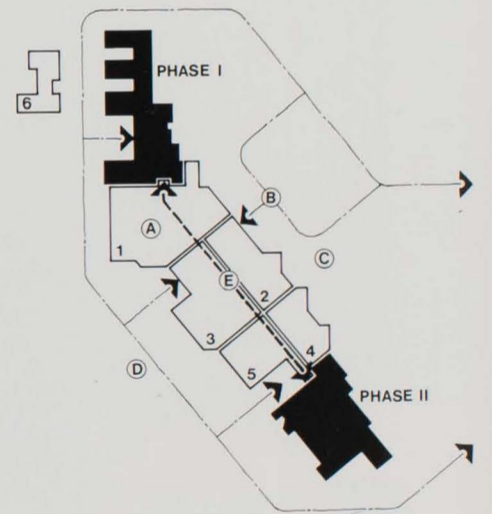

213.

Plan Revised to Respond to Master Plan Goals

(characteristics)

- A - Phase III development based on six functional clusters, prioritized in terms of functional impact, accreditation requirements, construction costs and funding opportunities
- B - provides primary central entrance to complex
- C - client and student circulation located in zone at front of structure
- D - service circulation and animal activities in zone at rear of building
- E - service and circulation spline

"...correspondence of the whole, with respect to the several parts, of the parts with respect to each other, and of these again to the whole."

Andrea Palladio



Appendices

Building Reference

No. Building Name	GSF	Year Bldg Comp			
1 Lane Hall	26520	1888	182 War Memorial Gym	200961	1975
4 Rasche Hall	62491	1957	183 Indoor Tennis Courts	21550	1975
5 Brodie Hall	65037	1957	185 Lane Stadium	N/A	1965
6 Shanks Hall	55413	1957	186 Rector Field House	71189	1971
7 Major Williams Hall	64673	1957	187 Coliseum	226617	1963
8 Monteith Hall	35960	1949	188 Schultz Hall	55390	1962
12 Thomas Hall	37775	1949	189 Dietrick Hall	92907	1970
13 Femoyer Hall	35538	1949	195 Owens Hall	97668	1939
22 Eggleston Hall	108513	1937	196 Printing Plant	22532	1931
24 Newman Hall	55017	1964	201 Security Building	9316	1890
25 Vawter Hall	58852	1962	202 Power House	28171	1960
26 Barringer Hall	42879	1962	203 Laundry	36333	1936
27 Miles Hall	41450	1964	204 Central Refrigeration Plant	3745	1971
28 Johnson Hall	35960	1965	226 Incinerator	2349	1950
29 O'Shaughnessy Hall	69211	1966	240 Motor Pool	4998	1970
30 Lee Hall	159278	1966	241 Central Stores	20240	1963
31 Pritchard Hall	211481	1966	242 Maintenance Building	56117	1958
32 Ambler-Johnston Hall	272019	1969	251 Donaldson Brown Center	106424	1967
35 Slusher Hall	125868	1972	252 University Club	8763	1930
36 Campbell Hall	66503	1939	274 Center for Public Choice	10931	1902
38 Undergraduate Dorm	81114	1983	275 Solitude	5133	1859
54 Hillcrest Hall	47768	1940	276 Wright House	3231	1923
61 Special Purpose A	8560	1983	290 Equatic Ecology Lab	4000	1979
62 Special Purpose B	8437	1983	295 Golf Course Club House	3274	1910
63 Special Purpose C	8547	1983	301 Wallace Annex	5539	1914
101 Sandy Hall	12343	1924	317 Residence	1138	1955
102 Price Hall	55955	1907	318 Residence	1138	1955
103 Hutcheson Hall	50637	1940	368 Architecture Annex	15808	1920
105 Smyth Hall	54073	1950	369 TV / Film Building	5076	1920
106 Saunders Hall	31043	1931	370 Media Services Building	12618	1936
108 Seitz Hall	51000	1937	432 Horticulture Garage	1536	1954
109 Agnew Hall	12245	1939	433 Plant Pathology Greenhouse	7769	1960
110 Bio-Chemistry Lab	45737	1961	434 Storage Building	705	1954
112 Cheatham Hall	56010	1971	435 Plant Pathology Lab	7689	1967
115 Wallace Hall	49256	1967	437 Greenhouse	837	1953
118 Animal Sciences	146267	1981	438 Poultry Isolation	1158	1955
123 Food Science & Technology Lab	45678	1968	441 Vet Med Research Center	11280	1953
124 Greenhouse	29769	1967	443 Poultry Virus Holding	925	1957
127 Patton Hall	52750	1929	444 Poultry Virus Holding	925	1957
130 Holden Hall	42130	1940	445 Interim Vet Clinic	2236	1956
132 Norris Hall	72375	1962	446 Vet Med Multi-Lab	1818	1956
133 Randolph Hall	165918	1959	447 Virus Isolation Bldg 2	2236	1954
134 Whittemore Hall	72381	1971	448 Virus Isolation Bldg 3	2236	1956
135 Satellite Tracking Station	800	1974	449 Virus Isolation Bldg 4	2236	1956
140 Veterinary Medicine Phase 1	27500	1981	450 Swine Disease Research	896	1967
150 Veterinary Medicine Phase 2a	64580	1983	453 Mating House	6234	1952
151 McBryde Hall	132090	1971	454 Laying House	8529	1952
152 Williams Hall	46848	1952	455 Teaching Lab	3912	1957
153 Pamplin Hall	49060	1957	456 Laying House 1	12255	1957
154 Robeson Hall	66138	1960	457 Brooder House	11852	1957
155 Derring Hall	207848	1969	459 Poultry Research Lab	7658	1970
156 Davidson Hall	79965	1938	460 Battery House	6256	1970
172 Cowgill Hall	68417	1968	475 Judging Pavilion	7709	1962
175 Performing Arts Building	15900	1899	476 Dairy Barn & Milk House	13320	1950
176 Burruss Hall	158221	1936	479 Milk Barn	1134	1952
177 Newman Library	226630	1955	481 Loafing Barn	4961	1962
178 University Bookstore	40054	1975	483 Calf Barn	6601	1962
179 Henderson Hall	37403	1929	484 Bull Barn	2019	1962
180 Squires Student Center	162848	1969	485 Equipment Shed	4565	1962
181 War Memorial Chapel	6324	1960			

Master Plant List

The Master Plant List is comprised of landscape materials that, historically, have grown well on campus, provide a diverse palette of colors, textures, and densities to serve a variety of design intentions, are commercially available, require low maintenance, and are tolerant of the constant physical changes and vagaries characteristic of a campus environment.

TREES

American Beech
Fagus grandifolia
American Holly
Ilex opaca - Tree Form
American Linden
Tilia americana
American Sweet Gum
Liquidambar styraciflua
Austrian Pine
Pinus nigra
Baldcypress
Taxodium distichum
Blue Atlas Cedar
Cedrus atlantica "Glaucous"
Bradford Callery Pear
Pyrus calleryana "Bradford"
Canadian Hemlock
Tsuga canadensis
Clump River Birch
Betula nigra clumps
Eastern White Pine
Pinus strobus
European White Birch
Betula pendula alba
Golden Rain Tree
Koelreuteria paniculata
Green Ash
Fraxinus pennsylvanica lanceolata
Hopa Crab Apple
Malus hopa
Japanese Dogwood
Cornus kousa
Japanese Flowering Crabapple
Malus floribunda
Japanese Pagoda
Sophora japonica
Japanese Zelkova
Zelkova serrata
Leyland Cypress
Cupressocyparis leylandii
Little Leaf Linden
Tilia cordata
London Plane
Platanus acerifolia
Northern Red Oak
Quercus borealis
Norway Spruce
Picea abies excelsa

Pin Oak
Quercus palustris
Pink Saucer Magnolia
Magnolia soulangiana
Purple Leaf Flowering Plum
Prunus cerasifera "Thundercloud"
Red Bud Crabapple
Malus zumi calocarpa
Red Saucer Magnolia
Magnolia soulangiana "Rustica Rubra"
River Birch
Betula nigra
Royal Red Dogwood
Cornus florida rubra "Royal Red"
Sargent Crab Apple
Malus sargentii
Serbian Spruce
Picea omorika
Shademaster Locust
Gleditsia triacanthos inermis "Shademaster"
Skyline Locust
Gleditsia triacanthos inermis "Skyline"
Star Magnolia
Magnolia stalata
Tulip Tree
Liriodendron tulipifera
Washington Hawthorn
Crataegus phaenopyrum (cordata)
White Dogwood
Cornus florida
Whitehouse Callery Pear
Pyrus calleryana "Whitehouse"
Yoshino Cherry
Prunus yedoensis

SHRUBS

Angelica Yew
Taxus media "Angelica"
Bar Harbor Juniper
Juniperus horizontalis "Bar Harbor"
Billard Spirea
Spiraea billardii
Bloodtwig Dogwood
Cornus sanguinea
Compact Andorra Juniper
Juniperus horizontalis "Depressa"
Compact Andorra Juniper
Juniperus horizontalis "Plumosa Compacta"
Compact Japanese Yew
Taxus cuspidata "F & F Compacta"
Compact Pfitzer Juniper
Juniperus chinensis "Pfitzeriana Compacta"
Compact Winged Euonymus
Euonymus alatus "Compacta"
Convexleaf Japanese Holly
Ilex crenata "Convexa"
Cranberry Cotoneaster
Cotoneaster apiculata
Densiformis Yew
Taxus media "Densiformis"
Double File Viburnum
Viburnum plicatum "Tomentosum"

Flowering Quince
Chaenomeles lagenaria
Glossy Abelia
Abelia grandiflora
Greenwave Yew
Taxus cuspidata "Greenwave"
Helleri Holly
Ilex crenata "Helleri"
Hetz Blue Juniper
Juniperus chinensis "Glaucous Hetzi"
Hetz Japanese Holly
Ilex crenata "Hetzi"
Hetzi Juniper
Juniperus chinensis "Hetzi Glaucous"
Japanese Redleaf Barberry
Berberis thunbergii "atropurpurea"
Leatherleaf Viburnum
Viburnum rhytidophyllum
Lily Turf
Liriope muscari
Little Gem Cotoneaster
Cotoneaster adpressa prostrate "Little Gem"
Native Rhododendron
Rhododendron catawbiense
Persian Lilac
Syringa persica (Rothomagensis)
Pfitzer Juniper
Juniperus chinensis "Pfitzeriana"
Pink Star Magnolia
Magnolia stellata "Rosea"
Rock Spray Cotoneaster
Cotoneaster horizontalis
Rosy Glow Barberry
Berberis thunbergii "Rosy Glow"
Sargent Juniper
Juniperus chinensis "Sargentii"
Thumberg Spirea
Spiraea thunbergii
Wentworth American Cranberry Bush
Viburnum trilobum "Wentworth"

Credits

Project Director:

Warren R. Kark, AIA, University Architect
Director of University Planning

Project Manager:

Diana G. Tracey, AIA

Text:

Warren Kark with contributions by Ben Johnson, ASLA; Orrin Arvold, AIA; Vernon Mays, Diana Tracey

Photography:

Diana Tracey, Steven W. Gift, AIA; Keith Hughes (College of Architecture and Urban Studies), Vernon Mays, Tetsuo Makino, Paul Rohsner, Special Collections, Newman Library, Virginia Tech; Bob Veltri for (22) and Educational Communications (Publications Department, Virginia Tech)

Illustrations:

Ben Johnson (63, 65, 69, 91, 92, 93, 101, 103, 114, 115, 116, 120, 121, 122, 123, 124, 130, 137, 138, 165, 170, 175, 177, 178, 179)

Warren Kark (36, 84, 206, 207)

Michael Gebhart, AIA (TAC, Cambridge, Massachusetts) for (33, 34)

Graphics:

Diana Tracey, Steven Gift, Jane Greenwood

Publication Design:

Diana Tracey

Graphic Coordination and Layout:

Diana Tracey, Jane Greenwood

Editing:

Vernon Mays
Beverly Brinlee (Publications Department)

Publication Consultant:

Jeffrey Clare
Clare Advertising

Current Capital Projects- Professional Consultants:

(82) Food Processing and Storage Facility
Marcellus, Wright, Cox & Smith
Richmond, Virginia

(83) Forest Products
Architectural Design Group
Roanoke, Virginia

(85) Business Infill Increment
Smithey & Boynton
Roanoke, Virginia

The Architect's Collaborative
Design Consultant
Cambridge, Massachusetts

(86) Chemistry Infill Increment
Perry, Dean, Rogers and Partners
Boston, Massachusetts

Graphic Preparation:

American Lithoplate, Inc.
Roanoke, Virginia

Learning Resources Center
Virginia Tech

Malcolm Blue Print & Supply Corp.
Roanoke, Virginia

Roanoke Engraving Company
Roanoke, Virginia

Mechanical Production (maps):

Sheri Daniel, Jane Greenwood, William Tate,
Noni Parsons, Diana Tracey

Typesetting:

Virginia Tech Printing Plant
Jane McWilliams (Water Resource Research
Center)

Printing:

Virginia Tech Printing Plant
Harry Damant, Director

Recognition must be given for the efforts of: Donald Bergeson, Architect (School of Architecture, University of Illinois); Benjamin Johnson, ASLA; Tetsuo Makino, Architect; Donald Sunshine, AIA (College of Architecture and Urban Studies, Virginia Tech); and Diana Tracey, AIA - who participated in and contributed significantly to the development of this plan during the summer of 1981 in a special studio session.

Those credited above are past, and/or present staff in the Office of the University Architect, Virginia Tech, unless otherwise noted.