

AN EXPLORATION OF A HYPERBOLIC PARABOLOID AS AN OFFICE BUILDING

by Valerie Cohen

Thesis submitted to the faculty of Virginia Polytechnic
Institute and State University in partial fulfillment
of the requirements for the degree of:

MASTER OF ARCHITECTURE

November 1993

Dr. Milka Bliznakov

chairperson

Wolfgang Schueller

Robert Schubert



Dedicated in memory of my
grandparents:

and
and

I wish to express my gratitude to my thesis committee: Professor Milka Bliznakov, Professor Wolfgang Schueller, and Professor Robert Schubert for their faith, patience and guiding hands.

A special thanks to my parents; and , and to my brother for their strength and optimism.... and financial support.

I am deeply grateful to Professor Michael O'Brien for his help and encouragement.

I am thankful for all my wonderful friends, most especially , and for pushing me along the way.

And thanks to for making my thesis year so special.

An Exploration of a Hyperbolic Paraboloid as an Office Building

by Valerie Cohen

The purpose of this thesis was to create a structure that is a result of a hyperbolic paraboloid shell (hypar). As a result of this, a certain order evolved which dictated the form, the structure, and the environmental aspects of the two buildings designed. Through the design of the hypar walls, came the opportunity and/or need for daylighting. This is the conscious design of a building form to use direct sunlight for illumination and thermal benefit. Buildings so designed respond both to direct sunlight and to sunlight modified through diffusion or reflection by the sky vault, clouds, natural or man-made elements of the landscape, and the buildings themselves. The workers occupying these buildings spend a major portion of their day in a place that could have psychological and physiological affects. Sunlight gives reassuring orientation to time, place, and weather, as well as producing interior environments that are comfortable, delightful, and productive.

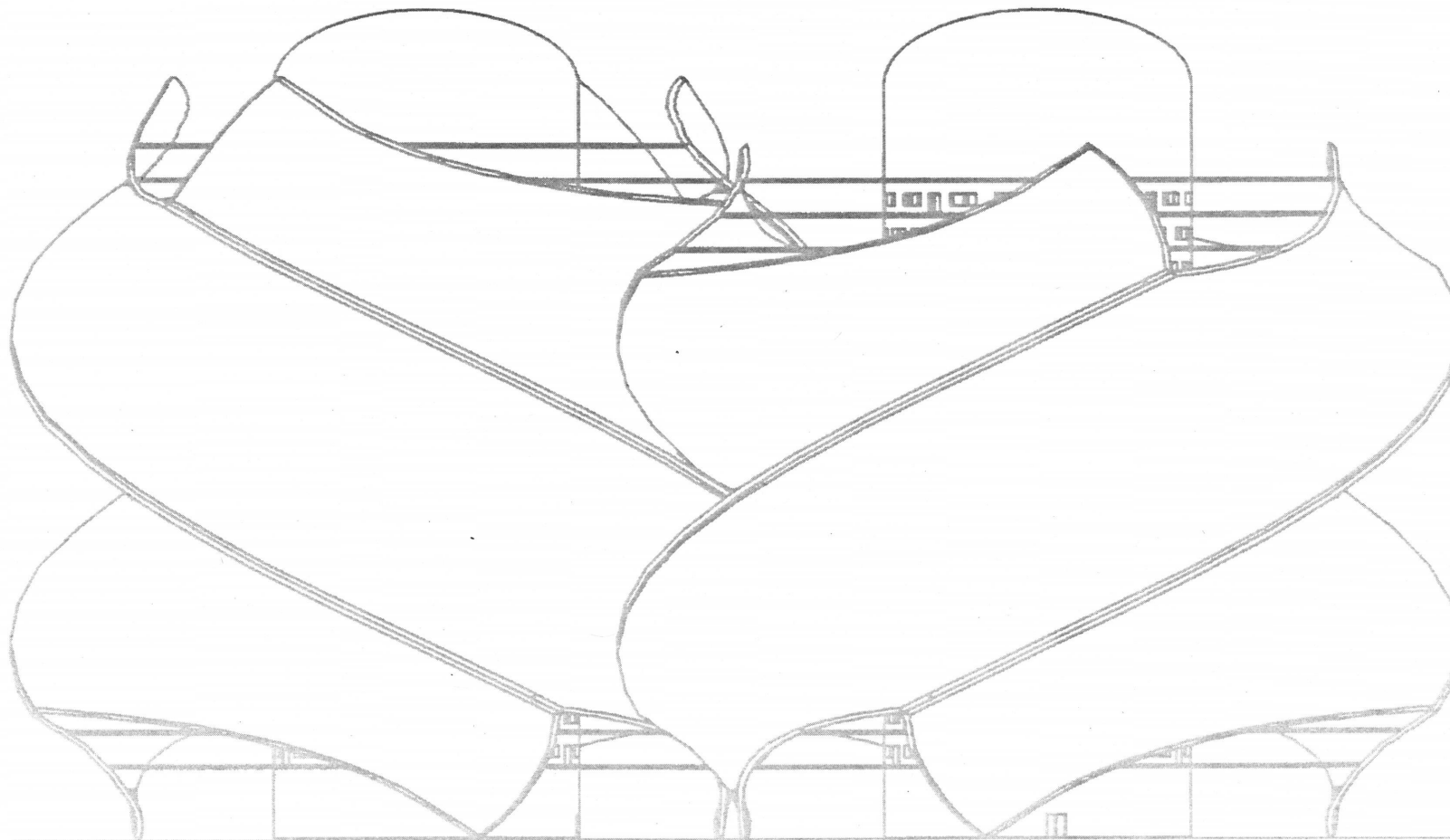

Title	i
Acknowledgements	ii
Abstract	iii
Contents	iv
Technology and glass box	1
Site	6
Hyperbolic Paraboloid	7
Concrete	8
Structure	9
Project	11
Conclusion	23
Bibliography	24
Vita	25

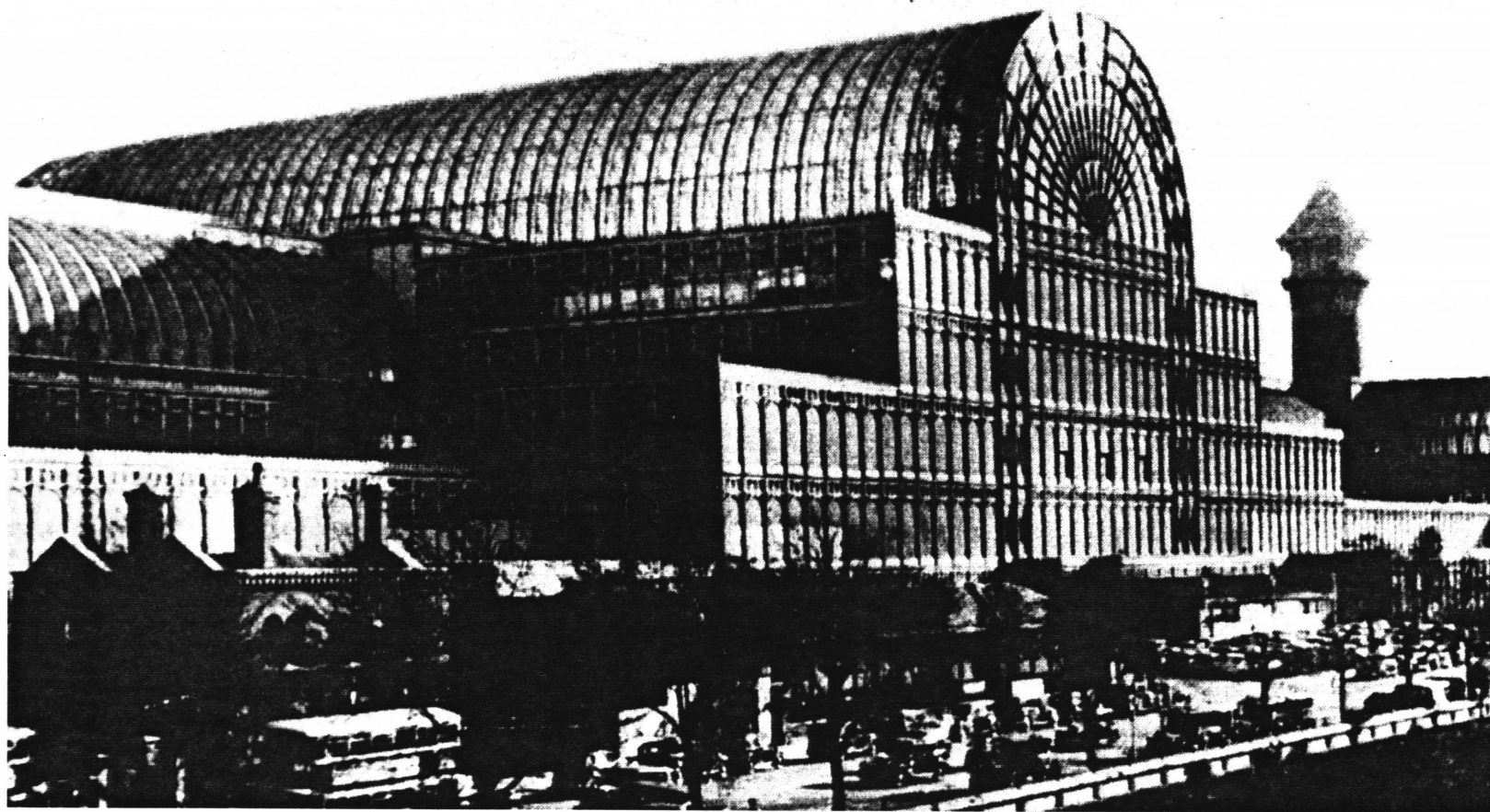

The Crystal Palace, London (1850).

Light has been a determinant of form in architecture since ancient times. In the early days of Greece, scarcity of heating wood, caused by the destruction of forests, created a need for solar aligned streets. Roman builders facing a similar predicament began using transparent mica as glazing on the south sides of homes. In the U.S., the Pueblos of the southwest developed advanced urban strategies based on an understanding and reverence of the sun. It was the medieval builder, one might say, who began using light in the modern sense. In medieval churches light was used to negate the anthropomorphic classical orders. "Dematerialization," writes Schultz, "was understood as a function of light, as divine manifestation.... Medieval man 'built' light, the most intangible of natural phenomena." Of course he was still limited by the technology of trabeated systems. The story of the glass box begins with buildings like the Crystal Palace. Although glass was mass produced in 17th-century Europe, it was Paxton that combined the new technology of iron, with glass, to create the prototype for the 'living machine.' The Crystal Palace was a model for the transparency buildings might achieve with iron, (and later steel), frames. It had social implications as well.

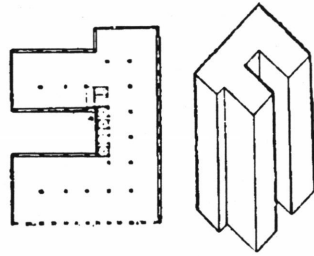

Guaranty Building,
Buffalo (1895)

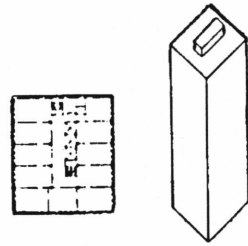

Alexander Building,
San Francisco (1925)

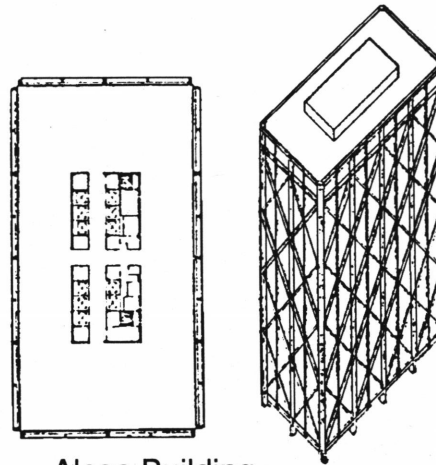

Alcoa Building,
San Francisco (1968)

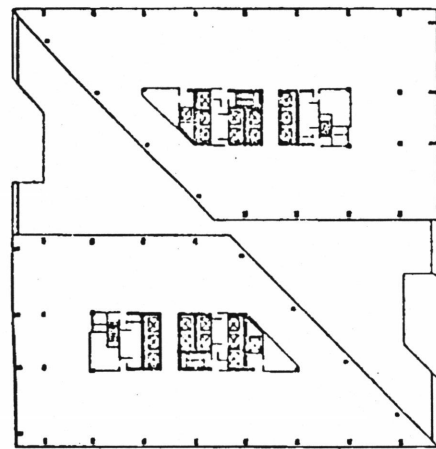

Penzoil Place,
Houston (1976)

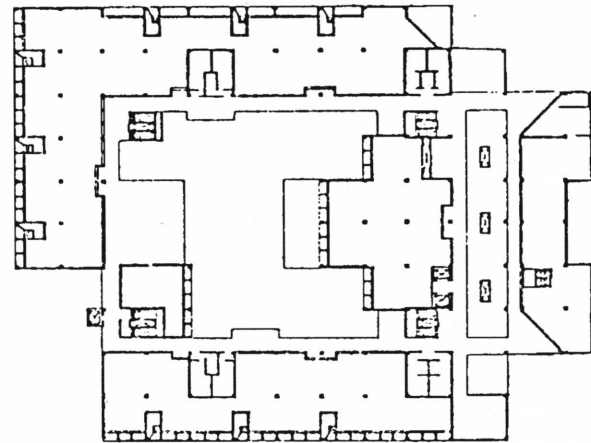
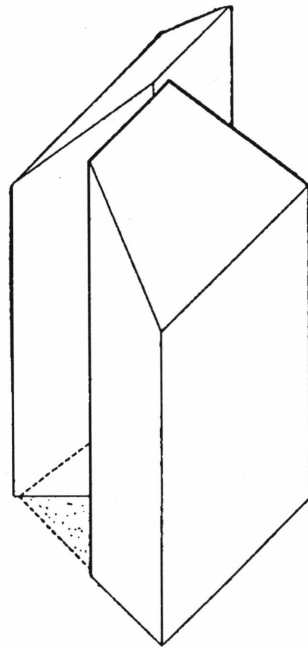

Proposed Sacramento
Office Building (1979)

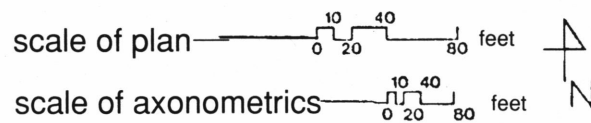

**Development of the Office
Building in the U.S.**

Tracing the development of the office buildings in the 20th century, we can see how some of the lessons of the Crystal Palace were lost, as the glass box grew to the monstrous dimensions of Penzoil Place. The variable to note in this development is the depth of the building envelope. Once maximum glazing and floor-floor height have been fixed, the depth of the room which can be effectively daylighted is limited. As depth increases, so does the ratio of light to dark, (glare). Proportion is ultimately more important than any single dimension.

Based on floor-floor heights for typical glass curtain-walled office buildings, the effective daylighting depth is 15-20 feet.

In the Houston office building, reflective glass used to cut down on glare and heat gain, reduces the quality and effective depth of daylighting. The Sacramento office building, on the other hand, utilized restrained glazing and adjustable shades and reflectors, to temper and redistribute sunlight. The height and width of the building are still based on the Sun's ability to penetrate the envelope, but it employs more efficient means, requiring less sunlight to reach a certain level of daylighting.

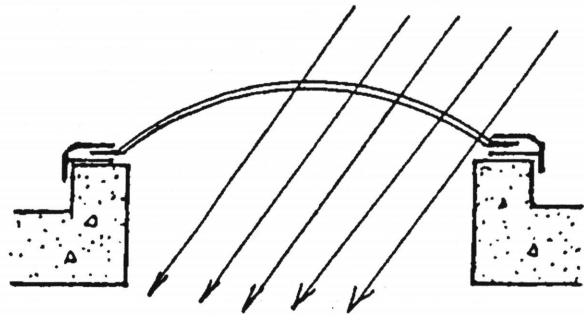

acrylic 'bubble-type' skylights are low-cost solutions, but may cause the same type of glare problems as small wall apertures.

directional skylights are much more selective in the type of sunlight they admit - less unwanted heat gain.

Fixed and directional skylight

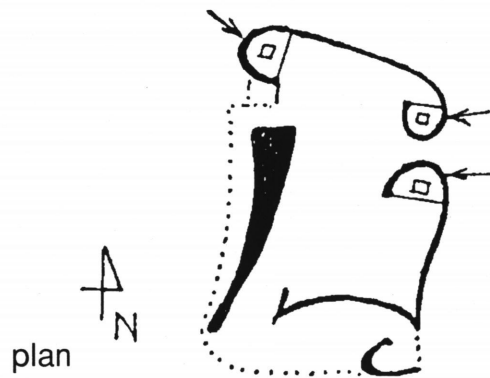

Cathedral of Notre Dame du Haut, Ronchamp

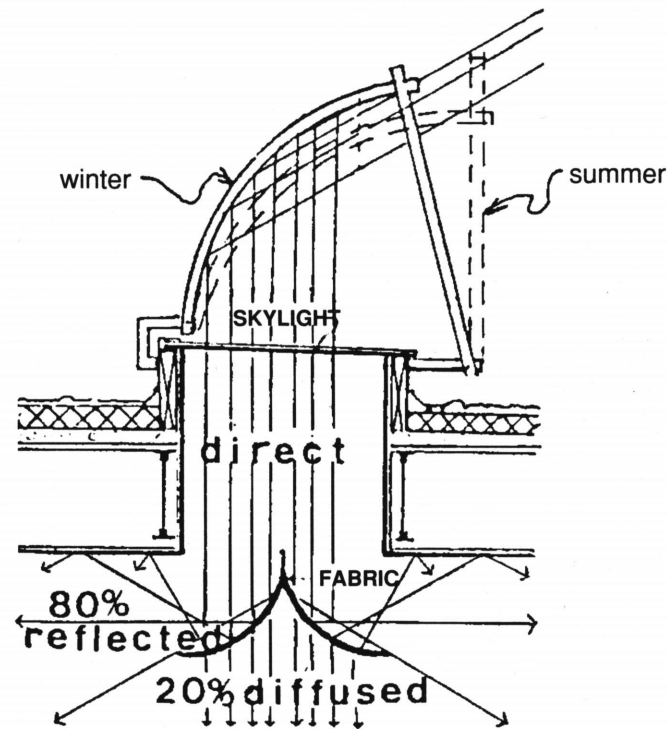

Window Rock Elementary School in Arizona. Fabric reflector/diffuser design.

Bouncing daylight, in effect increases the luminous surface area when ceilings or walls act as diffusers. The same amount of sunlight that causes glare problems in a small aperture can be spread more evenly to all parts of the room. Since reflected light does not contain as much heat energy as direct sunlight, there is savings in energy costs, for both artificial lighting and air conditioning. The following examples show some of the techniques for bringing daylight deeper into the building.

Skylight/Roof Monitors

The sphere of the sun, in addition to the point-source of the Sun, emits substantial amounts of daylight. The light from a uniformly overcast sky, for instance, is two to three times greater overhead, as near the horizon. A clear sky is normally brighter near the horizon, except in the immediate vicinity of the Sun.

Roof monitors have been used for centuries in the Mediterranean countries to funnel wind and/or sunlight into homes, while allowing for the release of stratified heat. At the Cathedral of Notre Dame at Ronchamp, Le Corbusier placed a hooded monitor above each of the chapels. As the Sun moves around the building, light enters different towers, shifting the stage of focus within the building.

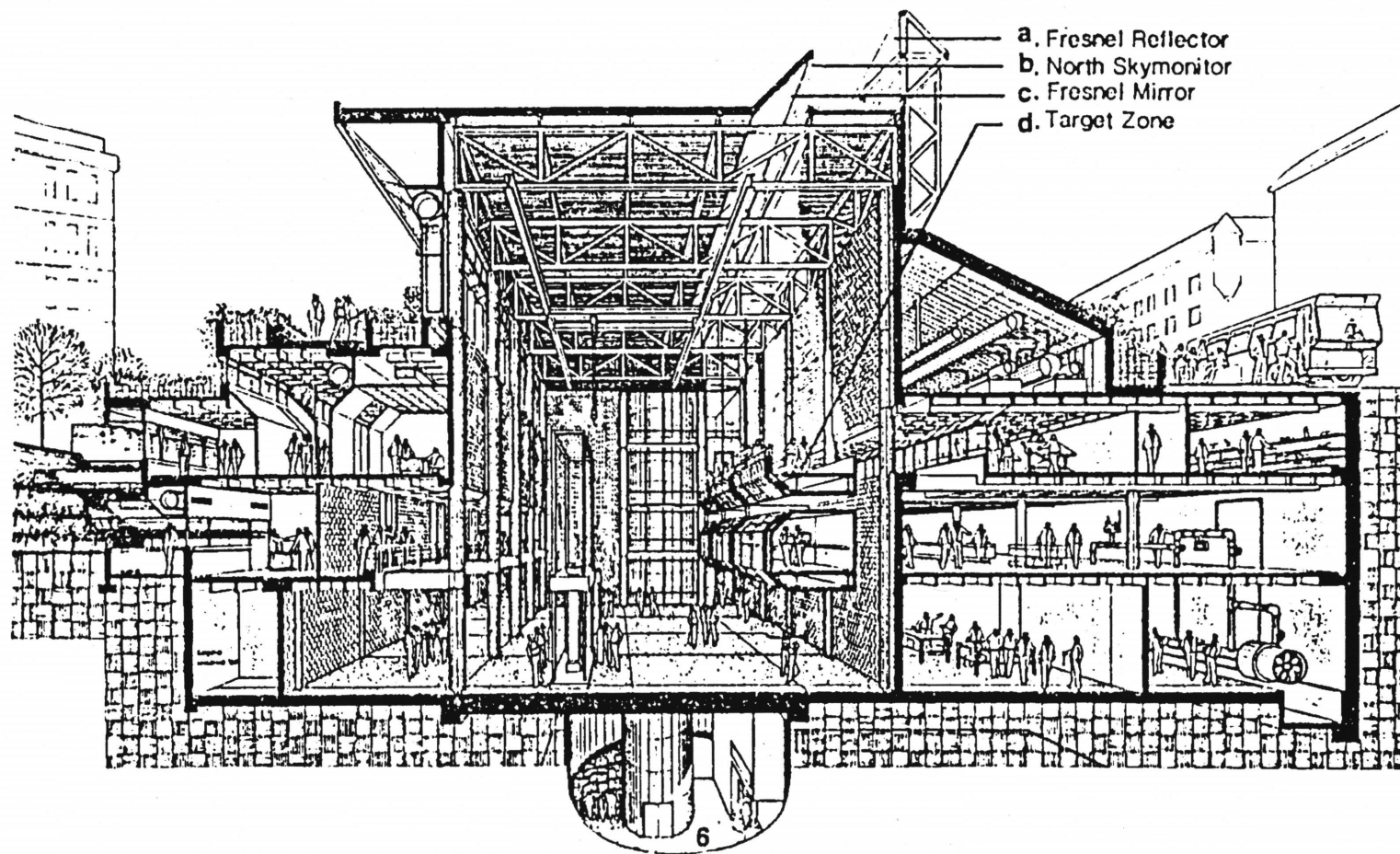

Beam Daylighting

BRW Architects adopted the strategy of beam daylighting in roof monitors, at the Civil Engineering Building of the University of Minnesota. Each heliostat, mounted in a rooftop penthouse, collects approximately 165,000 lumens of sunlight on 16.5 s.f. of mirrored, elliptical surface, (clear day). With 75% transmission efficiency, 412 s.f. of area deep within the building is illuminated (100 footcandles). The ratio is 25 s.f. of lighted space for each s.f. of heliostat reflector. While this level of technology may be appropriate, given the severity of Minnesota's winters, it is disproportionately costly in more temperate climates; where more traditional uses of daylight may suffice.

Passive Solar Optic System at Civil Engineering Building,
University of Minnesota.

Window Shelves/Wall Sections

Light Shelves can be incorporated into the design of wall sections to bounce daylight into a building. They reflect direct sunlight, sky radiation, and ground reflections into building envelope, while providing shading and glare control. Anyone who has walked across a field of snow on a bright winter's day has seen the principle of a luminous body at work. With light shelves, the ceiling of the room acts in the same way. In lower stories of buildings, light covered pavement and vegetation can contribute to daylighting, by acting as light shelves of sorts. The glazing in the top part of a light shelf system is usually clear, to allow for maximum light transmission. The viewing pane in the lower section is often tinted, and/or equipped with moveable shading devices. The added cost of light shelves is difficult to justify solely in terms of electric light and air conditioning savings. They are much more cost effective when integrated with the HVAC, acoustical, or electrical components of the building; as shafts for ducts, plumbing, etc. They should be designed high enough in the window wall as to prevent their use as storage space or planter shelves, since this reduces their effectiveness.

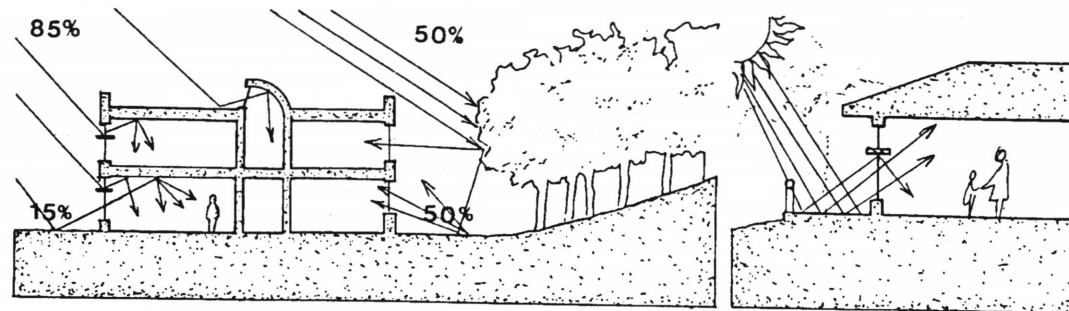

on sunny exposures, light reflected from the ground typically represents 10-15% of the light reaching window area - for unisolated exposures, ground reflections can be as much as 50% of total.

a terrace can act as a light shelf.

Effect of ground reflectance

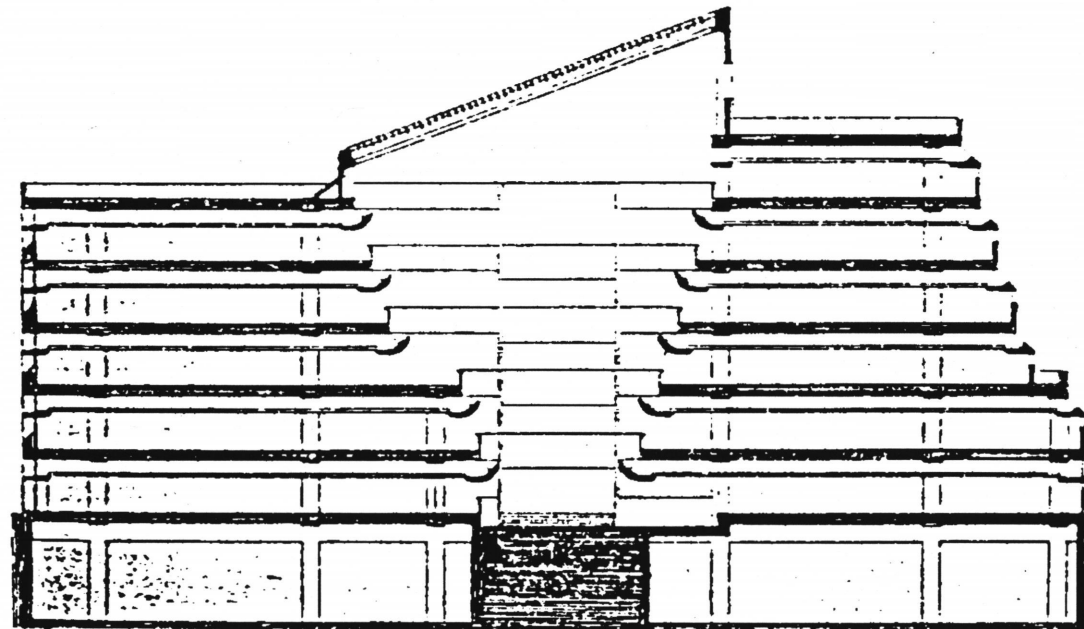

Tennessee Valley Authority Headquarters

Atriums/Internal Massing

The design for the TVA Headquarters, by CRS, TAC, Van de Ryn, Calthorpe and William Lam, uses all of the strategies mentioned so far. The skylit atrium collects light for distribution to six floors of offices. Adjustable mirrored louvers above the skylight focus light during different times of year, to control glare and heat gain. The interior light shelves also contain mirrors which redirect light from above into office cavities.

This concept of internal massing can be used in lobbies, corridors, dining halls, etc. Major spaces or rooms which have less stringent qualitative requirements for light, can be used to serve other parts of the building. The view aspects of these internal windows should not be forgotten; the solar collection space can be a visual amenity as well.

Site model

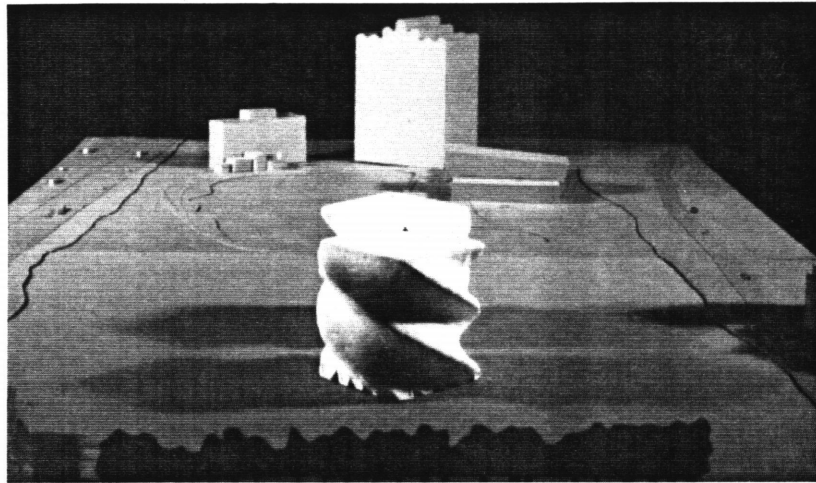

View of site facing the highway



Site model

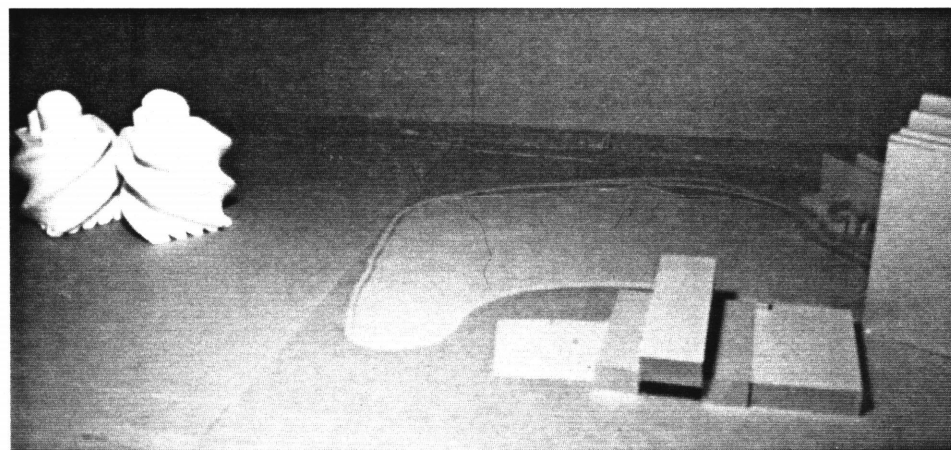

The site is located in Gaithersburg, Maryland. To the north of the site is a major highway, to the south, the access to the site, and to the east is a small lake. On this site were placed two office buildings facing each other at a distance of ten feet, along a diagonal axis.

Le Corbusier's Philips Pavilion

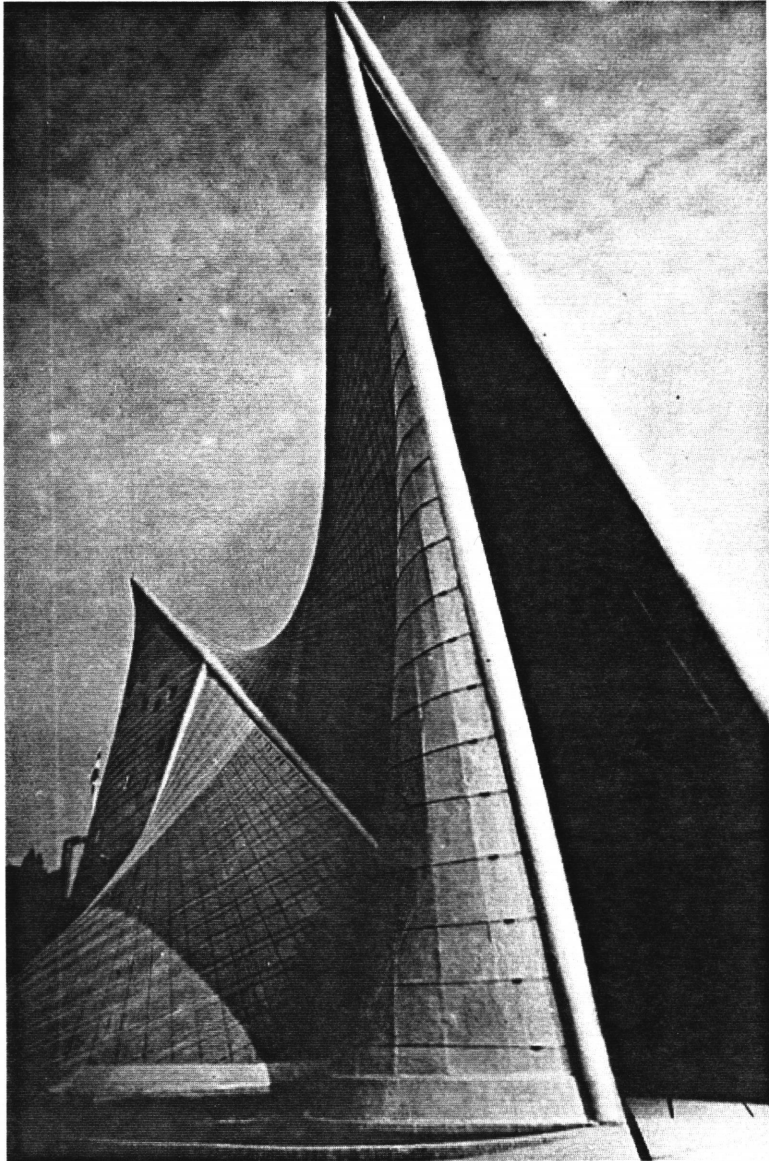

Nervi's Cathedral of San Francisco

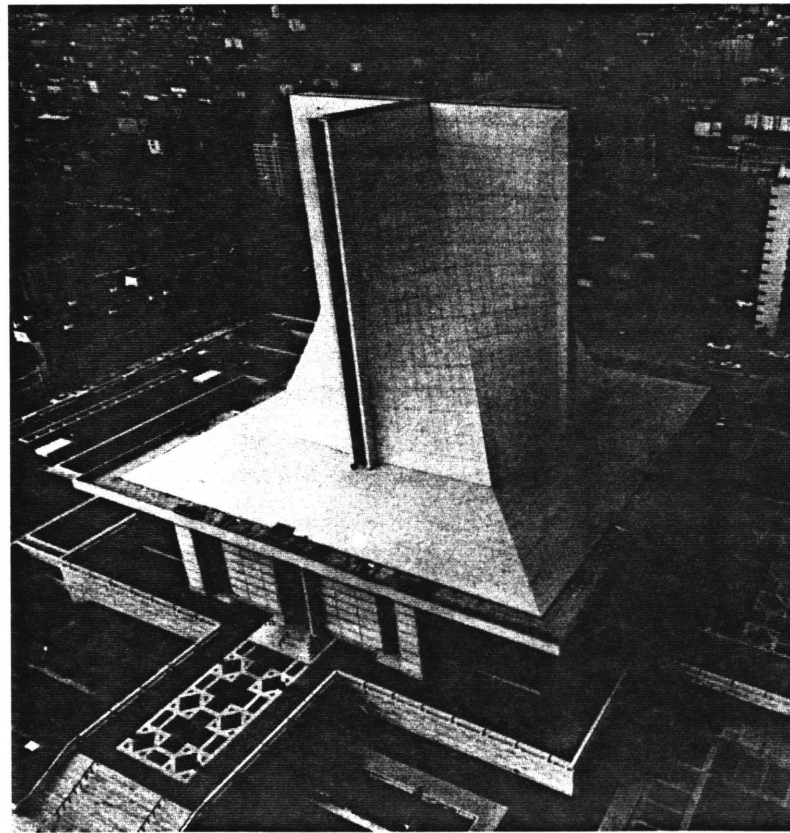

The hyperbolic paraboloid has wonderful properties. One would fear that it could easily buckle if it were not for the cable action.

The Spanish Architect, Felix Candela has become famous all over the world by designing and building, mostly in Mexico roofs that use only this surface as basic element. Even though the hypar has particularly efficient structural properties when used as a roof, Candela has shown how exciting it's form can be when used vertically as in the Iglesia de Virgen Melagrosa, Mexico City. Nervi has also used vertical hypars as walls and roof in the monumental Cathedral of San Francisco. Le Corbusier uses vertical hypars in the Philips Pavilion in the Brussels World Fair of 1958.

Figure 1 shows the composition of ordinary concrete. The binder consists of the water and cement, whose chemical reaction results in the hardening of the mass. The binder is mixed with some aggregate so that the binder coats the surfaces and fills the voids between the particles of the aggregate. For concrete the grain size is extended into the category of gravel, with the maximum particle size limited only by the size of the structure. The end product - the hardened concrete - is highly variable due to choices for the individual basic ingredients, modifications in the mixing, handling, and curing processes, and possible addition of special ingredients.

The primary strength of concrete is the specified compressive strength. Hardness of concrete refers essentially to its surface density.

Location of bars

When concrete is poured into forms and cured into hardened state, the concrete near the bottom of the member tends to develop slightly higher quality than that near the top. The weight of the concrete mass above produces a denser material in the lower concrete, and the exposed top surface tends to dry more rapidly, resulting in less well cured concrete near the top. This difference in quality affects the potential for bond resistance, so some adjustment is made for bars

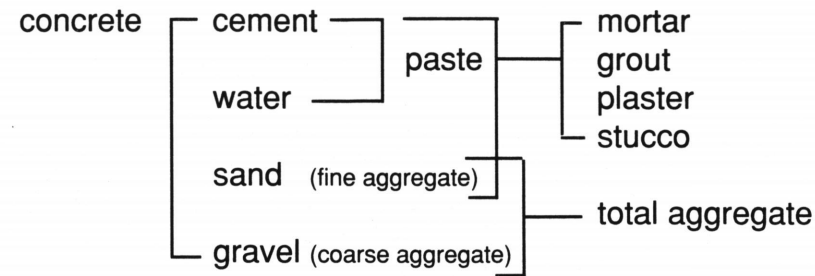

Fig. 1 Composition of ordinary concrete.

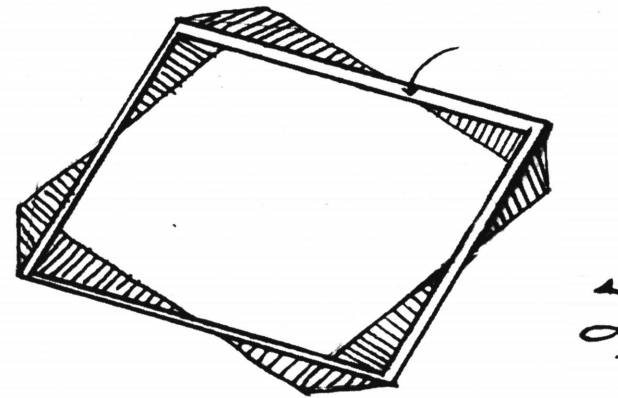

Fig. 2 Formwork sketch

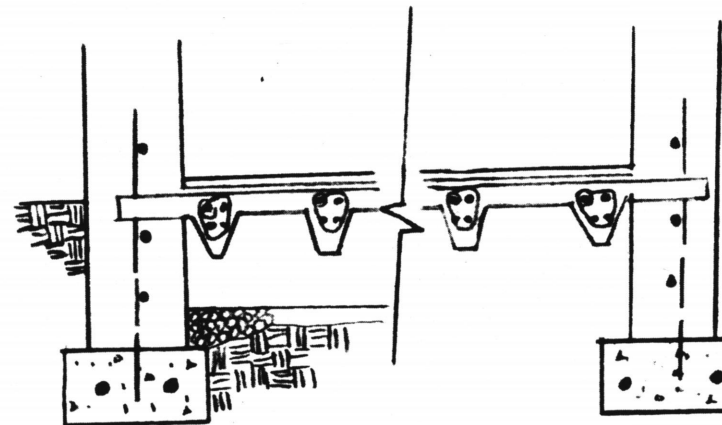

Fig. 3 Section detail

placed near the top (such as reinforcement for negative moment in beams).

For these buildings, the concrete is poured on the site with slip cast formwork that is rotated and raised as each floor is poured, as seen in Figure 2.

The presence of the very stiff concrete walls of the hyperbolic paraboloid shell and of the atrium make them attract loading because their relatively high resistance to deformation. Therefore, the reinforced concrete beams that support the concrete floor slabs are placed in the walls as each floor is poured (see Figure 3).

The floors are supported by a system of beams. The beams are made of reinforced concrete and are supported at one end by the core wall and at the other end by the hyperboloid of one sheet (hypar). The beam layout resembles that of a spider web, radiating out from a central core.

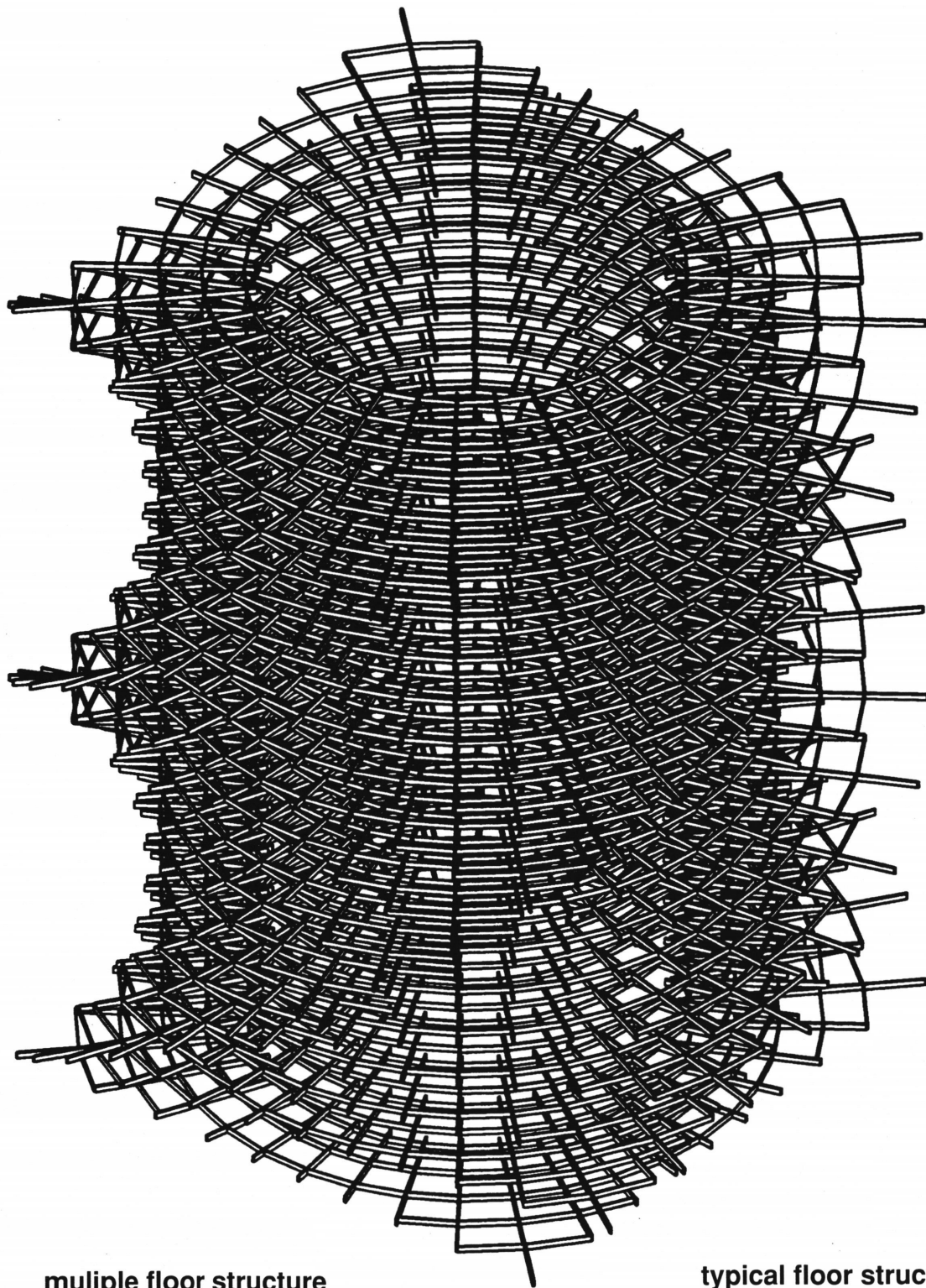

multiple floor structure

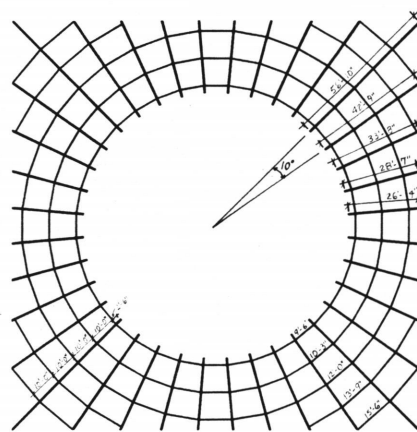

typical floor structure

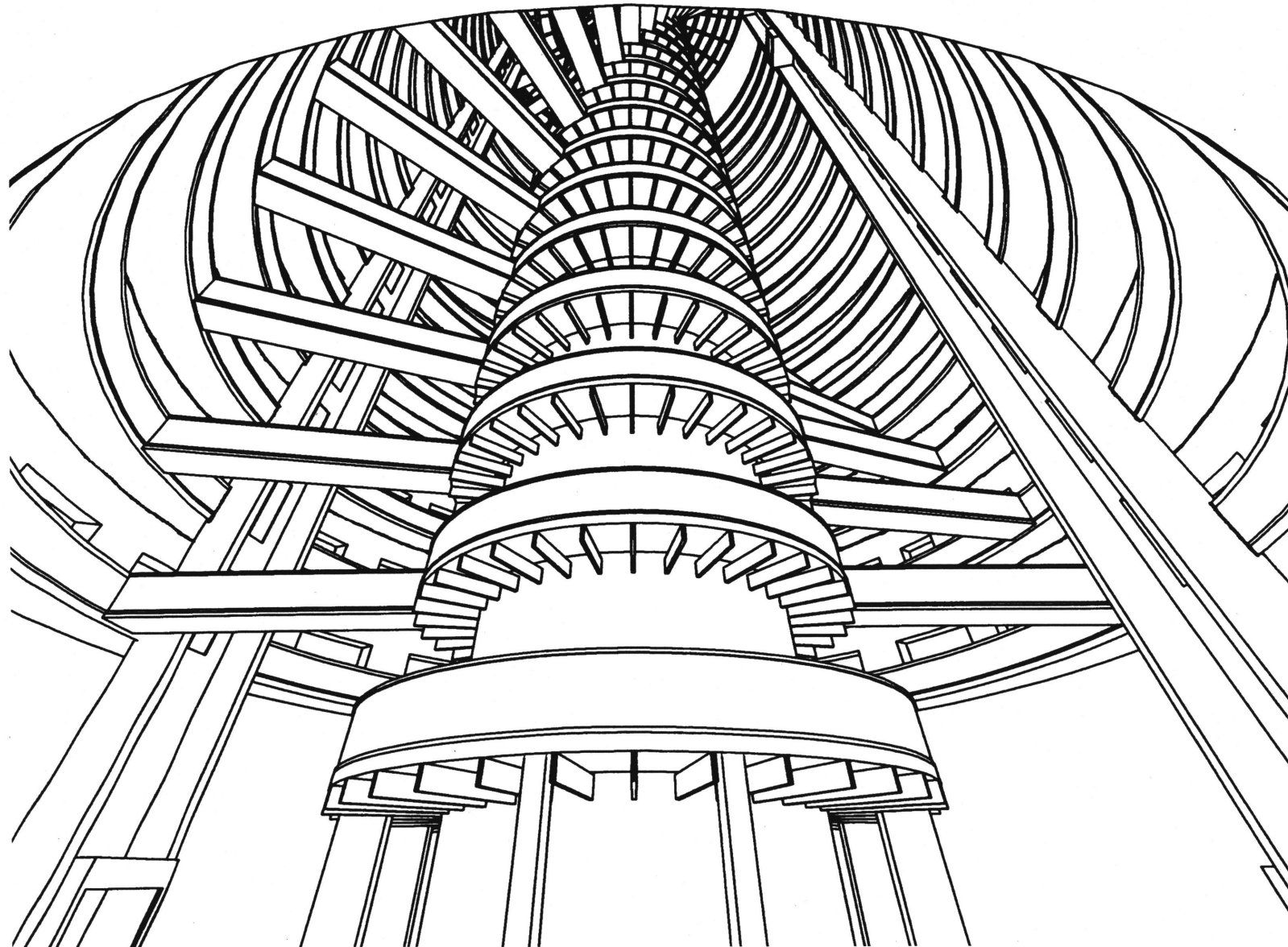

The atrium serves as a place for arrival and circulation, brings light and order and accommodates the core. In The New Atrium, Michael Bednar establishes a definition of the "new" contemporary atrium which attempts to relate different types of spaces through their shared characteristics.

ATRIUM: A CENTROIDAL, INTERIOR DAYLIT SPACE WHICH ORGANIZES A BUILDING.

This definition establishes three distinguishing characteristics of an atrium space:

-centroidal, which refers to the central, spatial organizing function of the atrium. Its position need not be limited to the geometric center of a building as long as the majority of spaces relates to it;

-interior, which refers to the enclosure (on all sides as well as overhead) of the atrium within the building;

-daylit, which refers to the provision of natural light within the space either through clerestories, skylights, or window walls.

The images seen here show the dynamic relationship between the two buildings.

On the following pages of the project one can see how the design of the windows and the spacing of the windows was generated by the curvature of the hyperboloid. The windows are spaced further apart following the curve and its exposure to light. Conversely, the windows enhance the dynamism and upward movement of the structure due to their spacing. The counter rotations of the buildings aids in the visual balance for them.

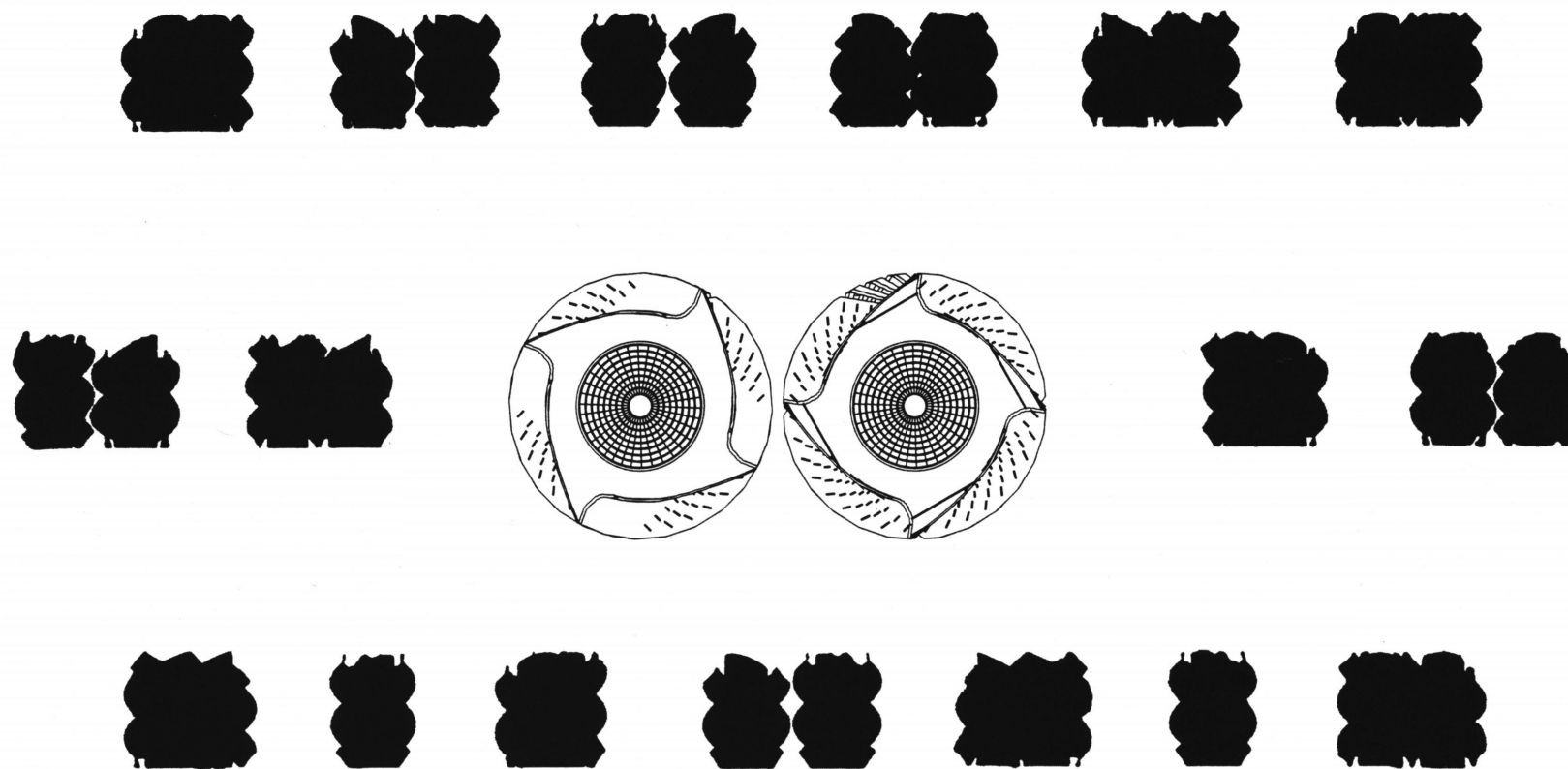

This axonometric view is taken from the south-east at a 45° angle from the ground.

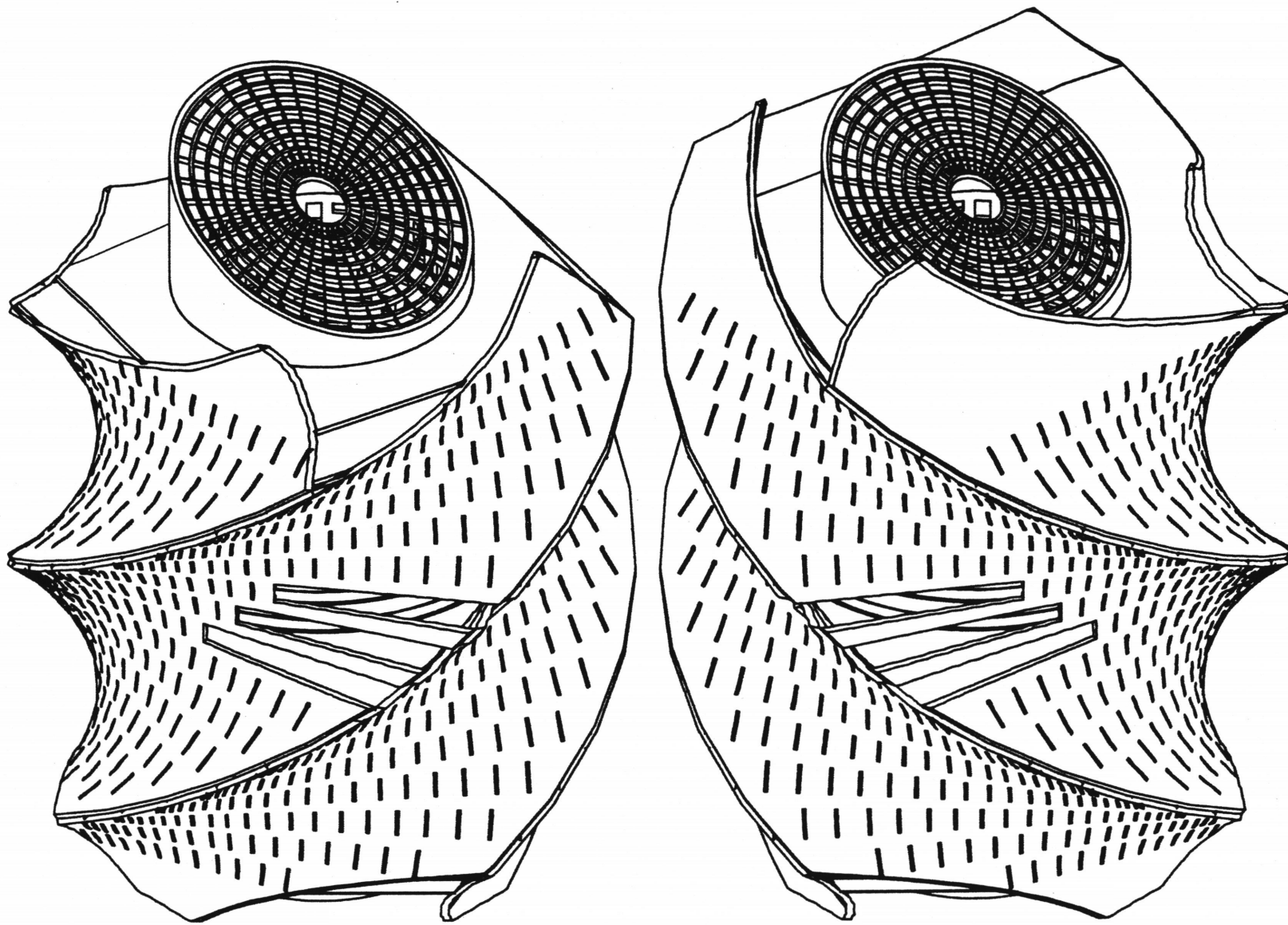

Axonometric View

This North-west to South-East section was taken directly through the center of the buildings.

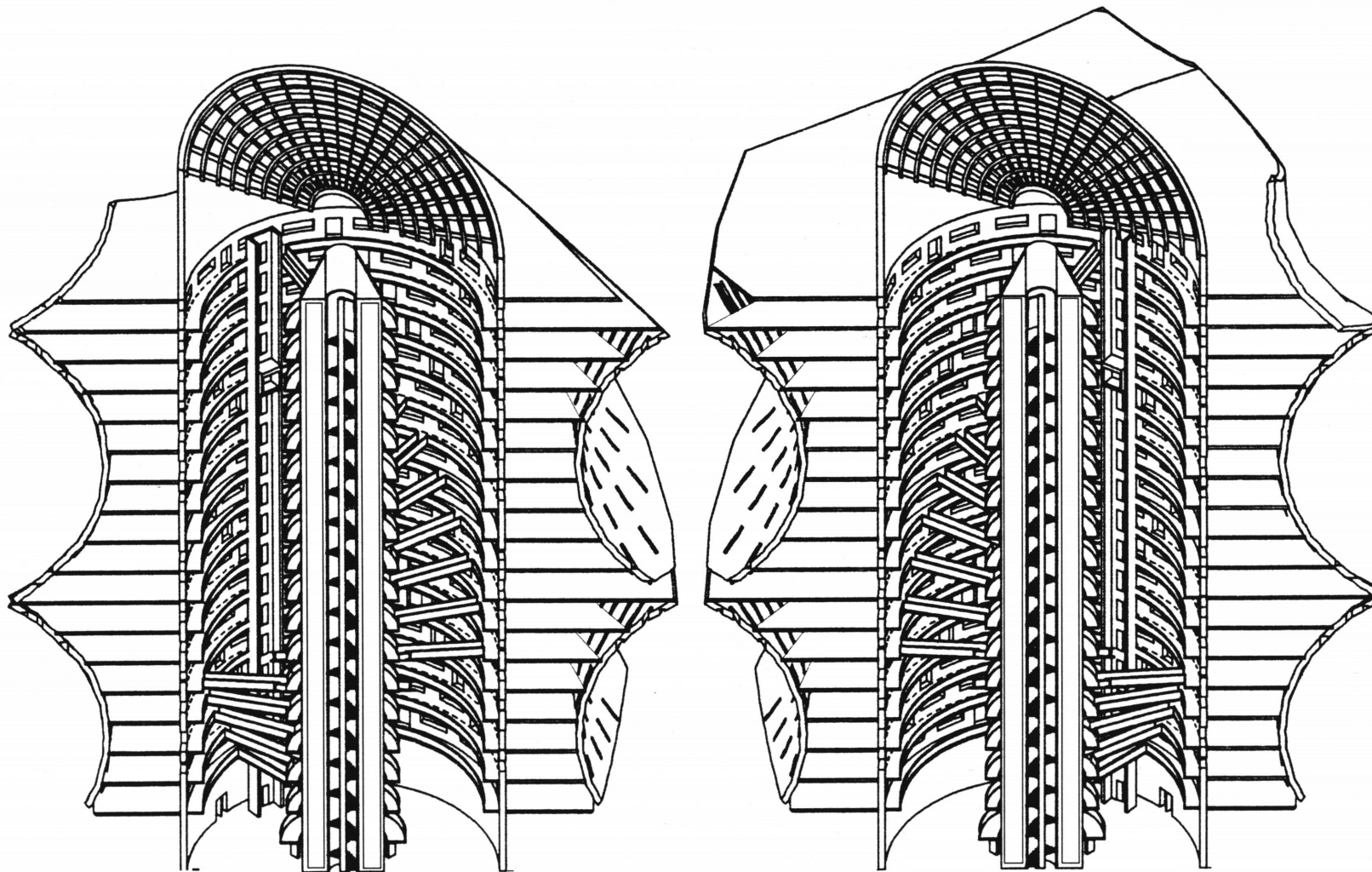

Axonometric Section

The east elevation is best seen while driving north-west along the highway.

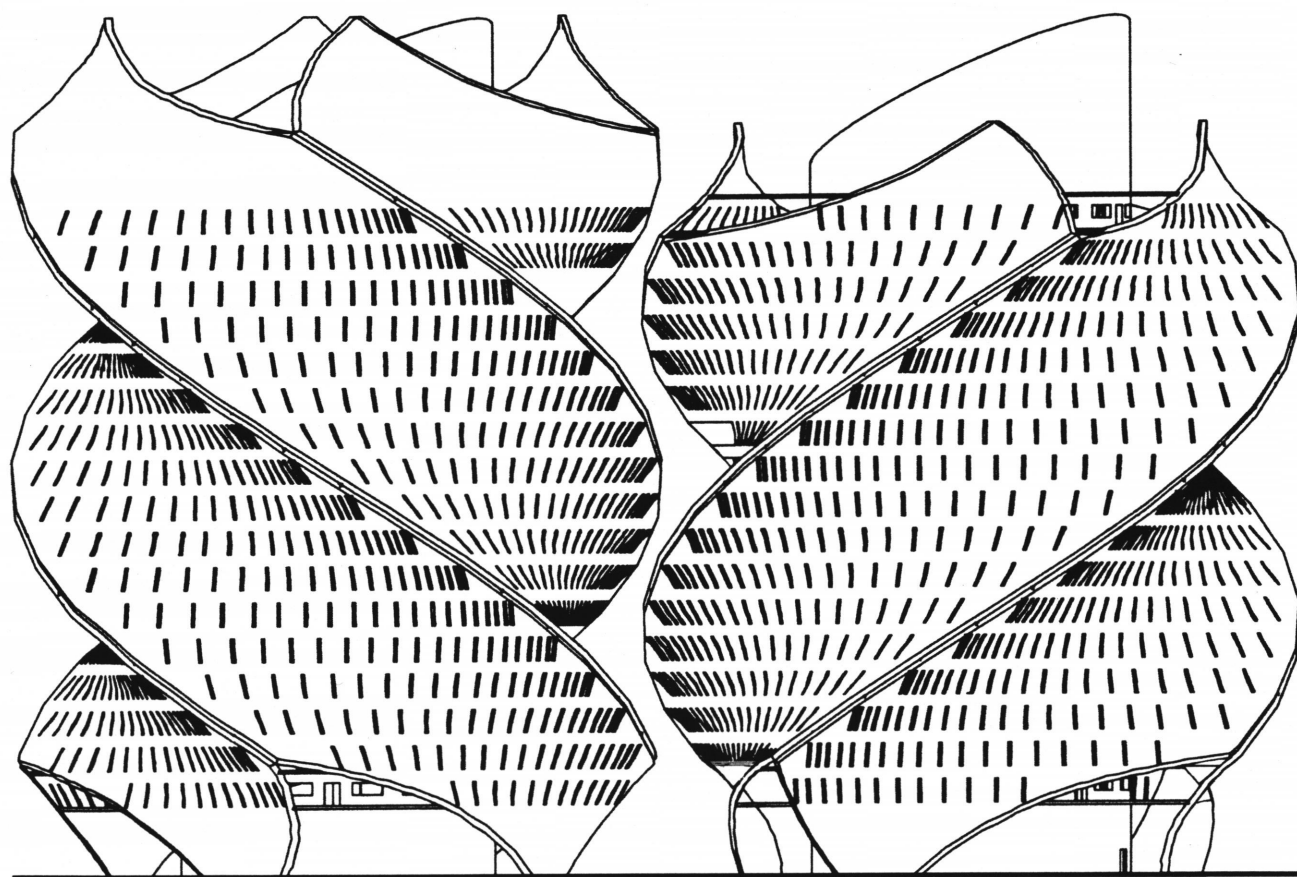

East Elevation

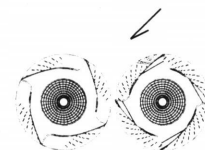

The North-West Elevation is visible when approaching the buildings from the parking lot or when walking around the buildings.

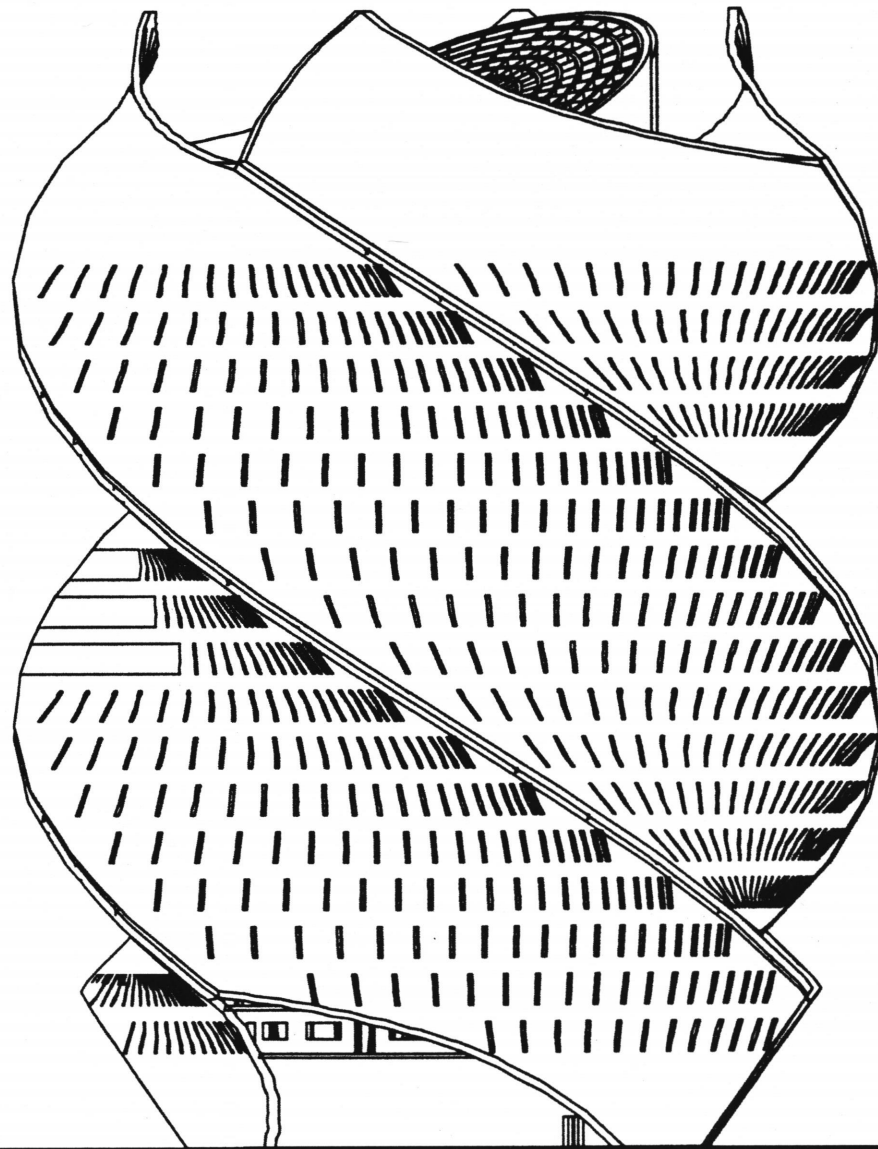

North-West Elevation

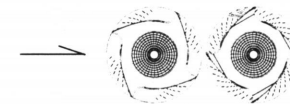

This elevation faces due south. The atrium skylights also face this direction in order to allow the most daylight into the atrium space.

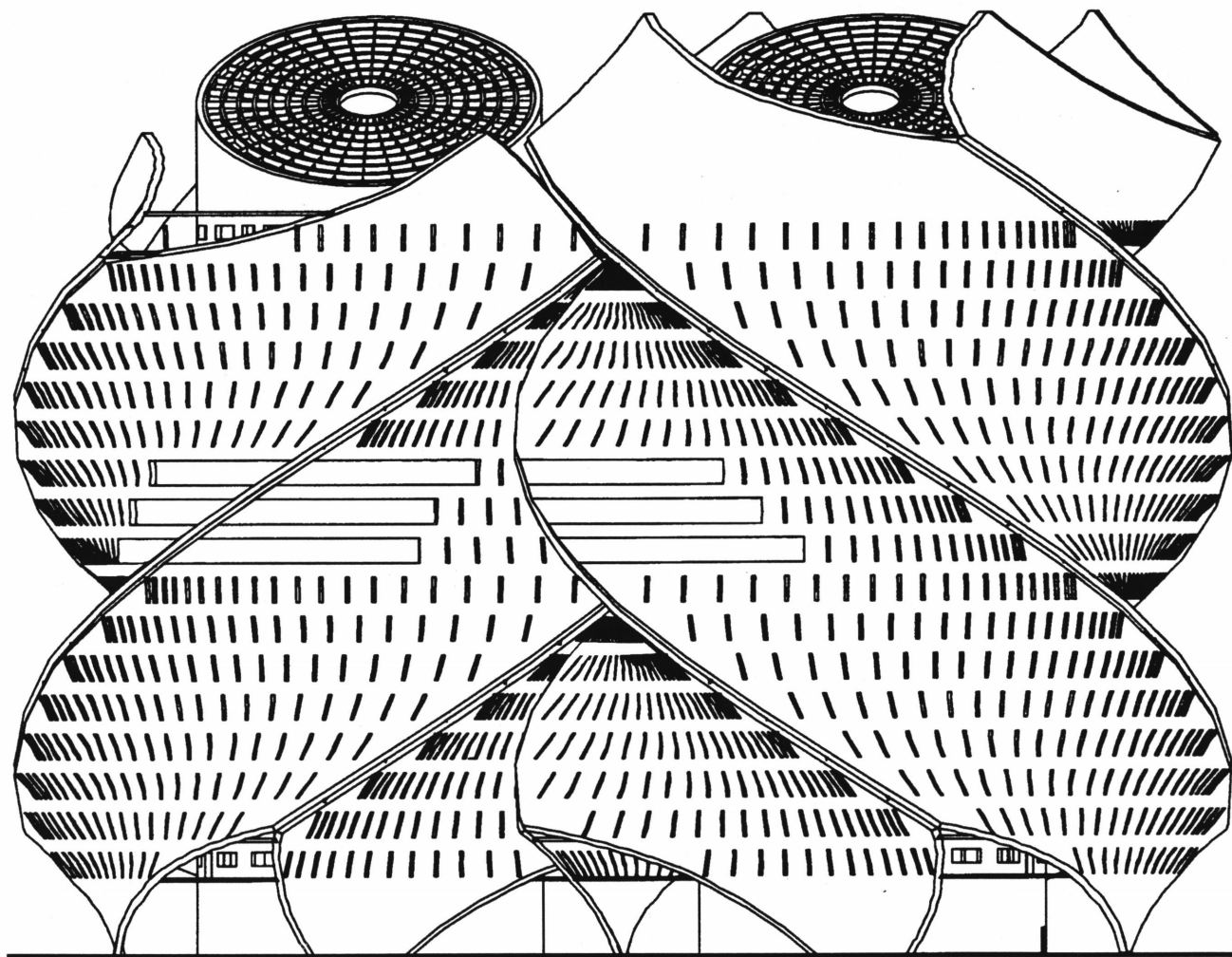

South Elevation

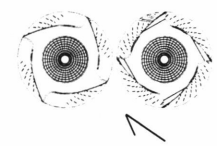

This elevation is what one would see if they approached the buildings from the access road.

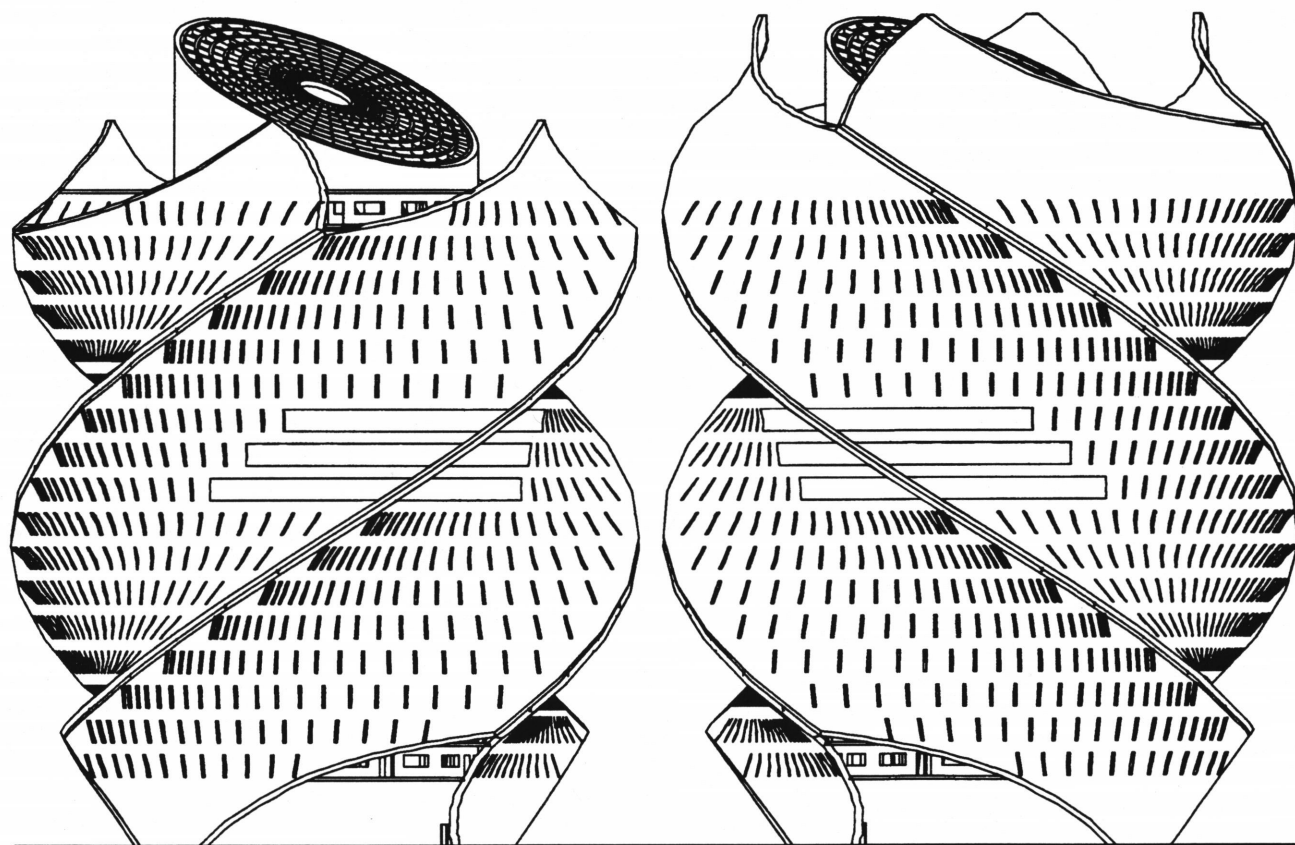

North-East Elevation

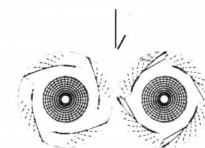

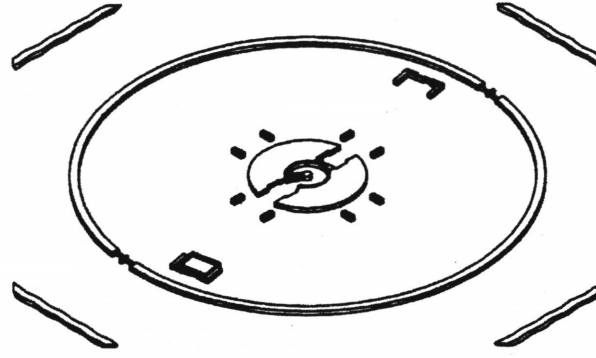
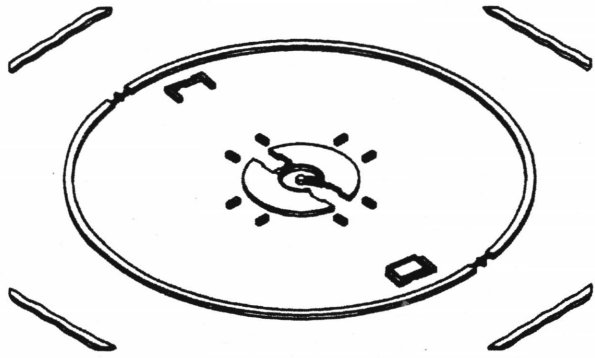

One enters these buildings on the first floor, directly into the lobby of the atrium. From this level, one can reach the offices by either taking the spiral staircase in the very center of the building or by the elevators located near the entrances to the building.

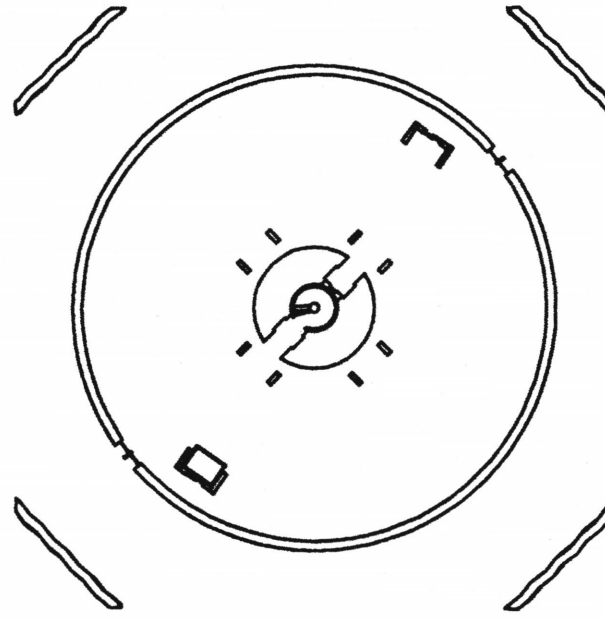
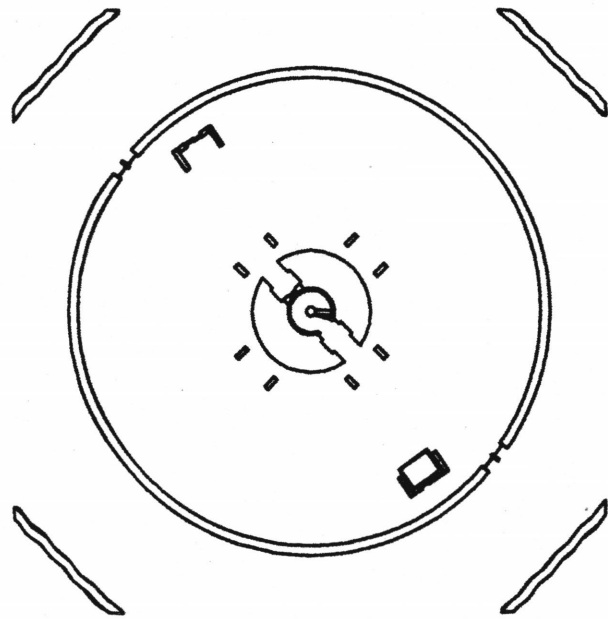

First Floor Axonometric Section and Plan

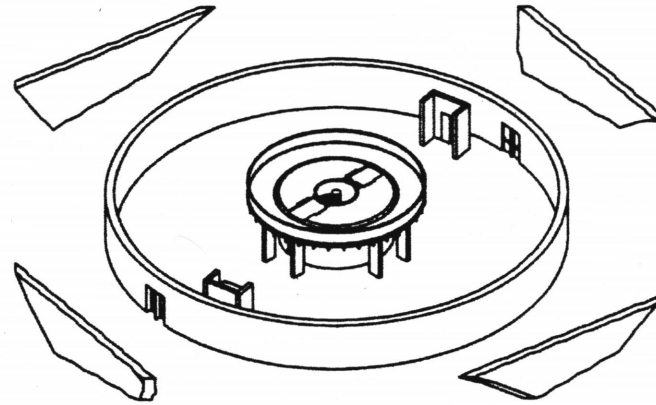
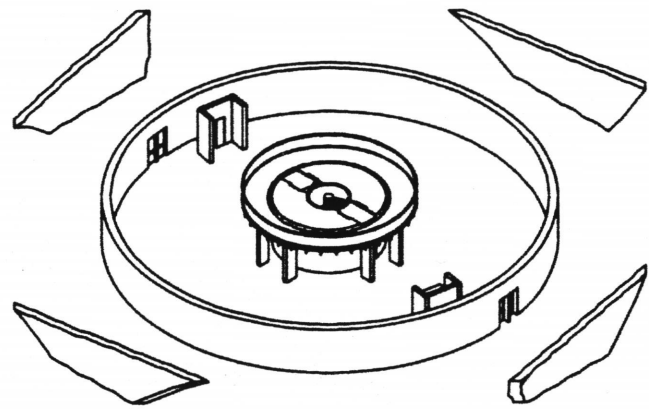

The second floor of the buildings do not provide office space but do provide a large balcony around the core of the atrium where a person can sit on a bench provided there and eat their lunch, talk with friends, or relax while observing the people below.

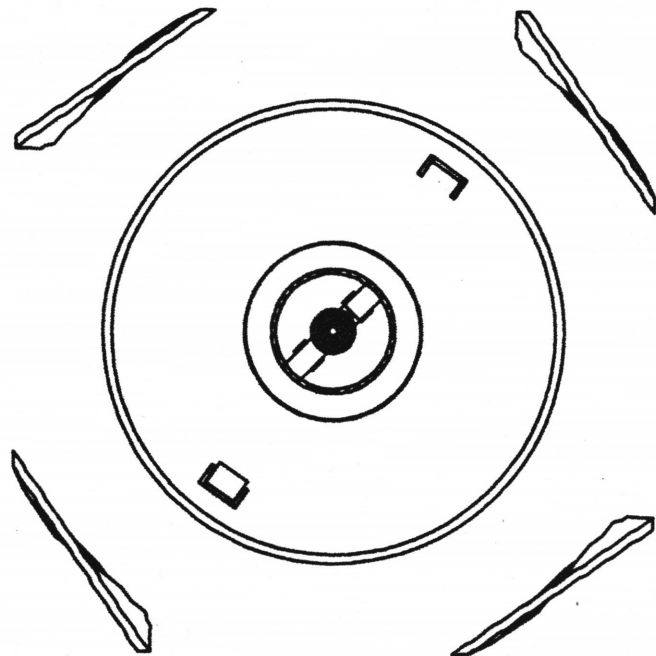
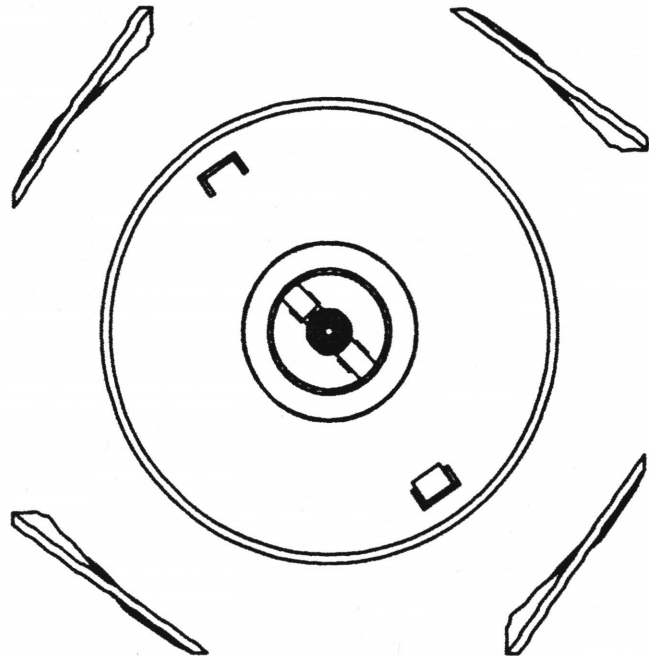

Second Floor Axonometric Section and Plan

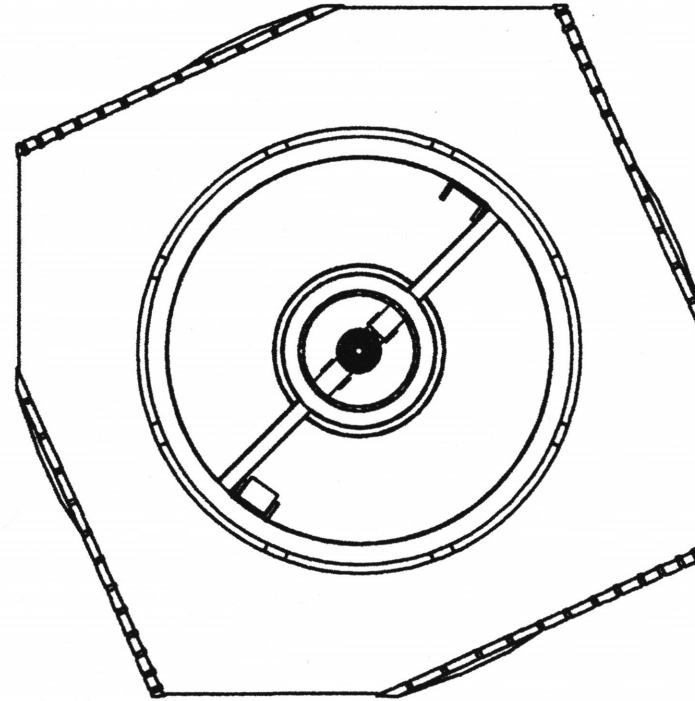
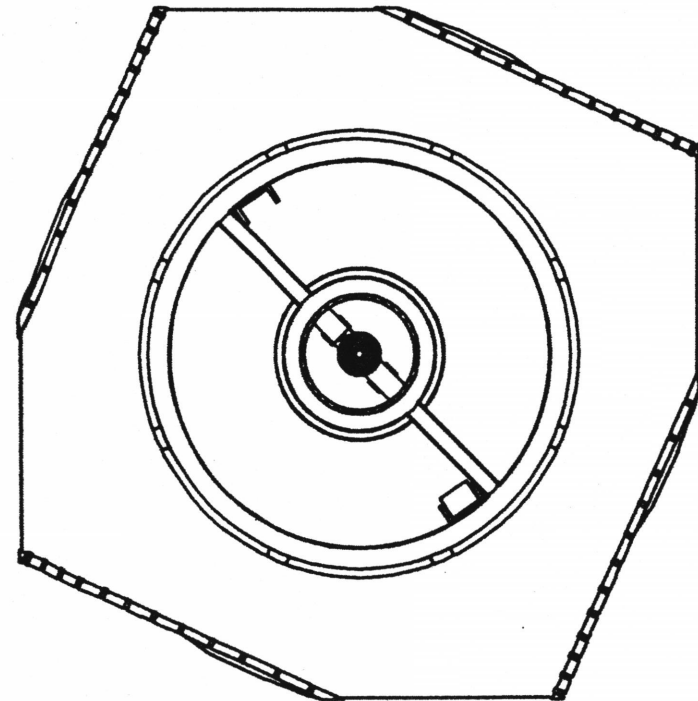
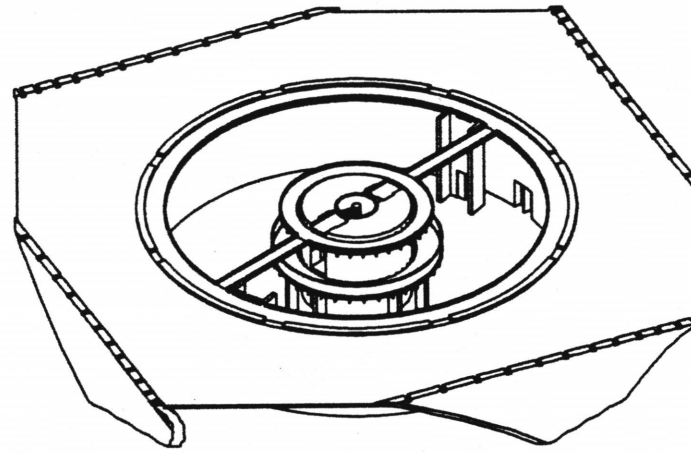
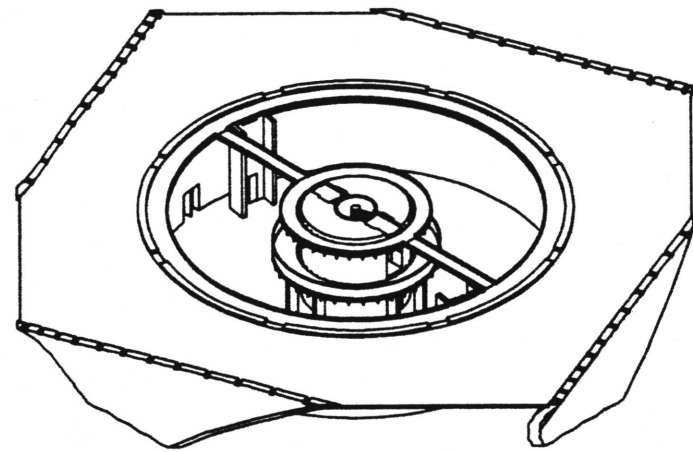

The third floor is the first floor that provides office space. As seen in the plan, this floor varies from the typical floor plan in the corners of the exterior wall where the building appears to have been cut at a 45° angle from the ground. This floor also allows some windows to follow the 45° cut. These windows do not get direct sunlight but they do receive reflective light from the ground and also from an overcast sky, which is prevalent for this site three-fourths of the year.

Third Floor Axonometric Section and Plan

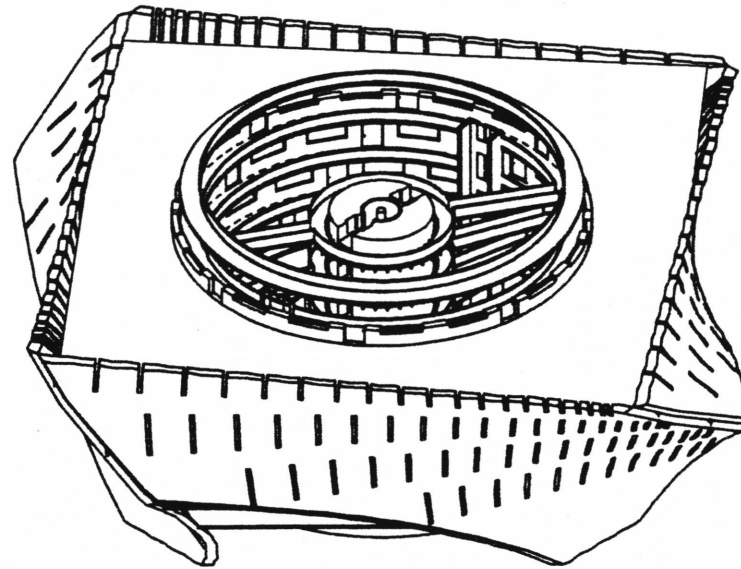
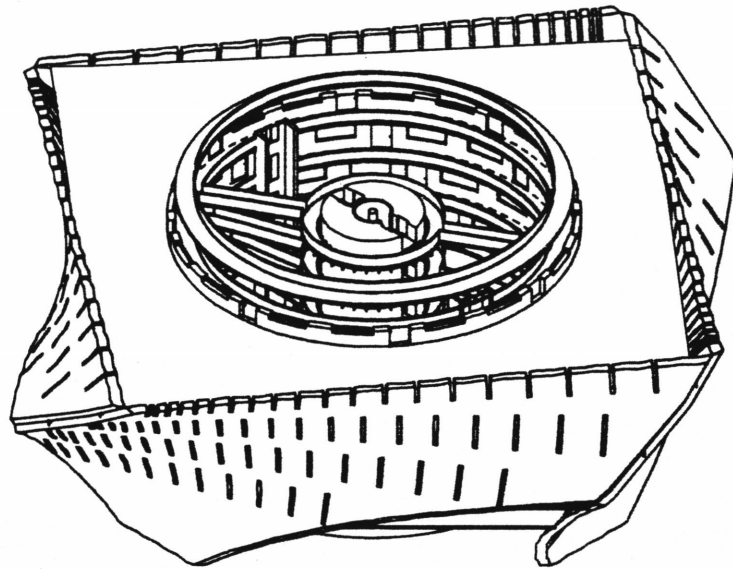

This section of the building shows how most of the floors appear. The typical floor plan also shows possible divisions for the offices. The office spaces can be rented in divisions of 1/8 of a floor up to a full floor, or multiple floors. Also shown on this floor plan are the bathrooms, which are provided on every level of the building. They are located in the center of the building, around the stairwell, and are accessible from the skywalks.

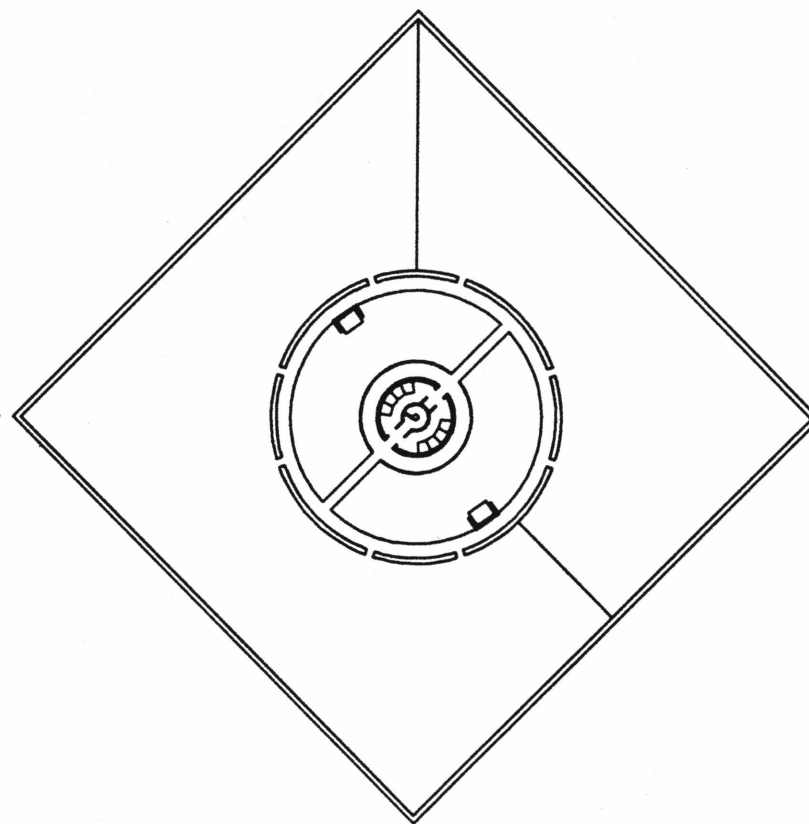
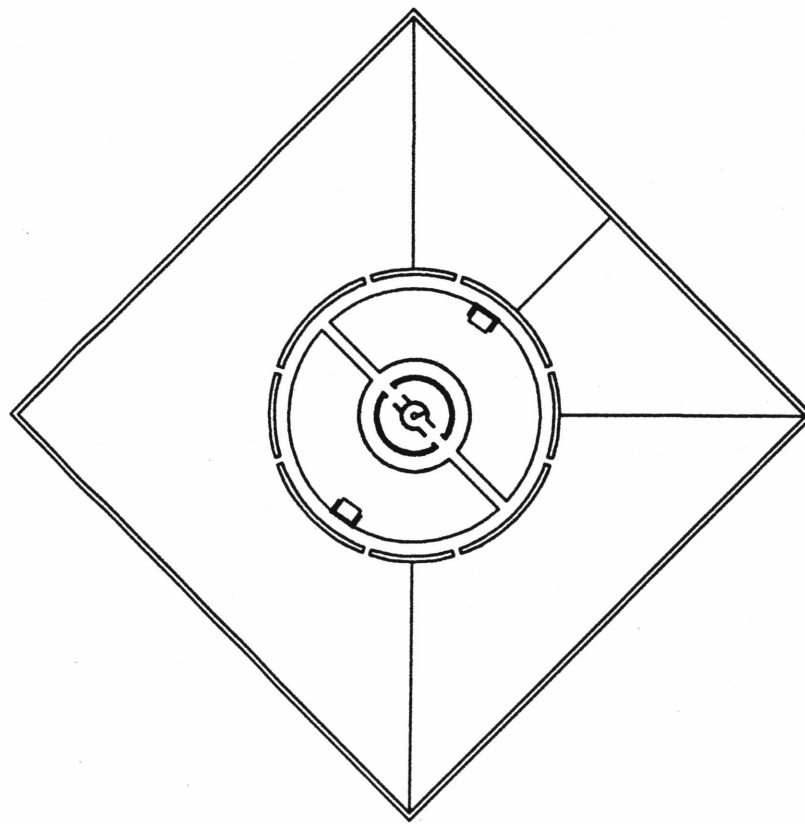

Sixth Floor Axonometric Section and Typical Floor Plan

The twelfth and thirteenth floors differ slightly from the other floors due to the subtraction of floor on the southern facades. This subtraction not only allows a grander interior experience of the curvature of the building but also allows a variation in the windows, thus allowing more light into a secondary atrial space from the thirteenth floor down to the eleventh floor.

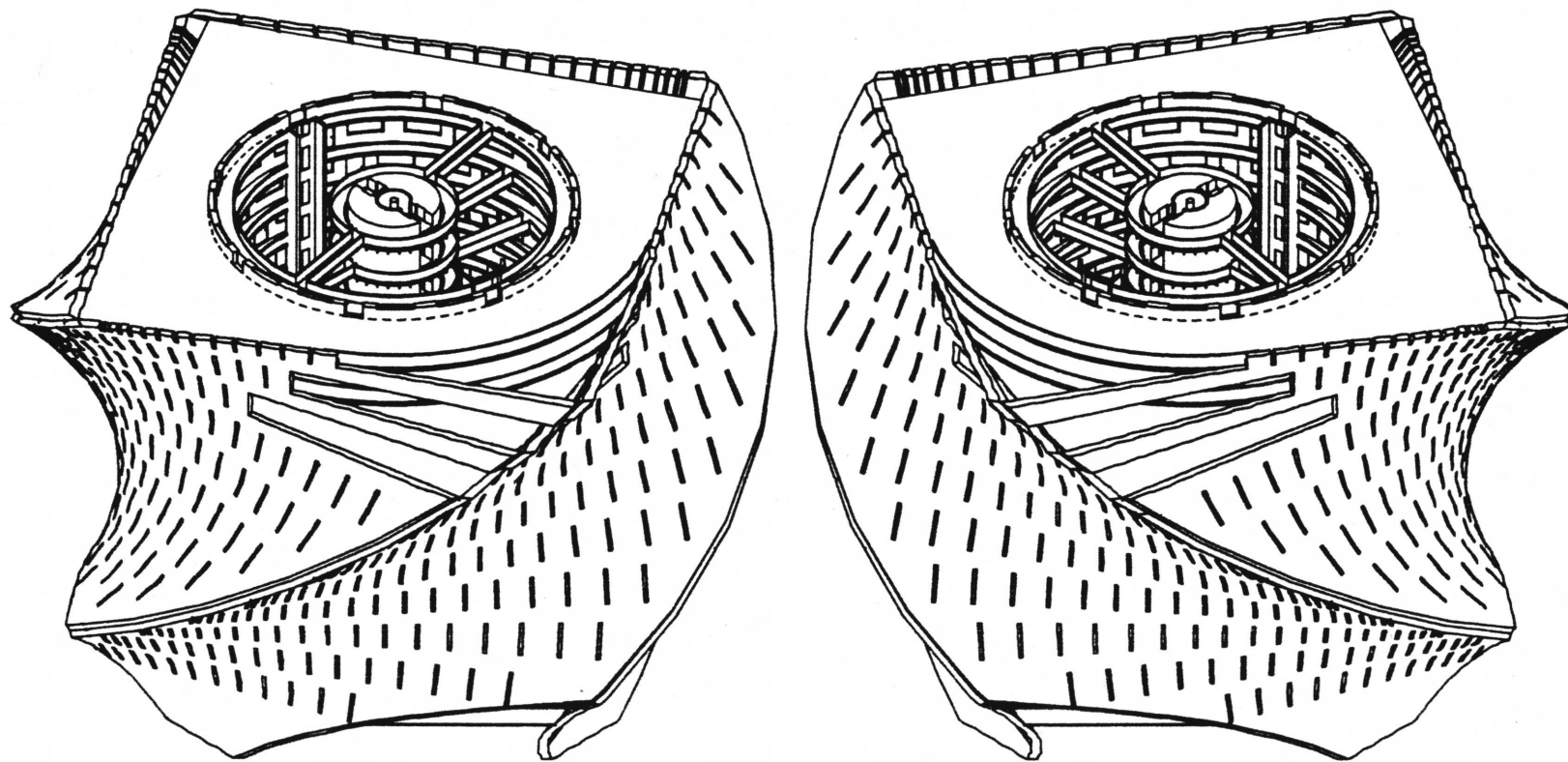

Thirteenth Floor Axonometric Section

So much of what we do as architects is guided by personal intuition. At the onset of this thesis, I set out to research the issue of a hyperbolic paraboloid shell and its dictation of the form, the structure and the environmental aspects of an office building, such as daylighting in architecture. The office, as a building type has been an effective vehicle with which to illustrate and test these ideas.

All buildings are defensive to some degree, be it against light, climate noise, vandalism, or for the privacy of the occupants. The architecture we have is traditionally associated with a strong defensive towards sunlight, because it has maintained a high ratio of solid-void in the exterior skin. In modern architecture, this is no longer the case.

Le Corbusier was among the first to employ the 'brise soleil' as a tempering skin for major areas of a transparent façade. The brise soleil used by Jose Luis Sert, in married student housing at Harvard, achieved an even more ephemeral quality. In both cases, however, there is an inherent dichotomy between the crystalline purity of the glass box and the defensive attitude towards the sunlight.

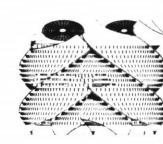
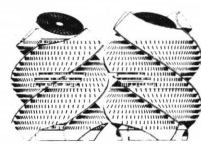
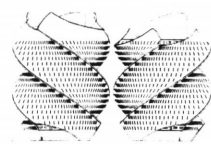
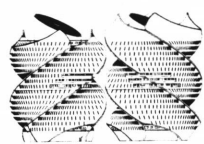
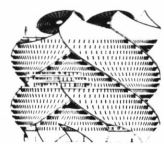

This is not to say that either of these architects built glass boxes, in the sense of Penzoil Place. Rather, it is the spirit of the Bauhaus' glass box that inhabits the buildings of both these men; a technical humanism. Sert and Le Corbusier employed glass for its transparent qualities, in contrast to the heaviness of the concrete skin used on the rest of the building. Both understood the human need for sunlight and view and used the latest technology to create modern 'machines for living.'

Herein lies the essential difference between the prismatic and glass office towers of the sixties and seventies, and the true glass box. As the Crystal Palace was a model for the quantity of sunlight that could finally be admitted into buildings, Le Corbusier and Sert showed that sunlight could be effectively controlled without losing the transparency. While some designers may choose to exploit the dichotomy, Man's fascination with dematerializing architecture continues. Glass towers that will inevitably be built in the next few years will have a wealth of technologies and lighting strategies available to them. The difference between glass sculpture and a sculptural architectural work, will depend on how well designers exploit these new strategies in the crystal palaces of the future. Only then can a true synthesis of light and form occur.

ARTICLES

- 1 Baron, Dr. Robert A. "Lighting as a Source of Positive Affect." Progressive Architecture, 71:123-125, November, 1990.
- 2 Benton, Charles C; Fountain, Marc. "Successfully Daylighting a Large Commercial Building: A Case Study of Lockheed Building 157," Progressive Architecture, 71:119-121, November, 1990.
- 3 Campbell, Robert. "Daylighting: Research and Design," AIA Journal, 72:54-57, June, 1983.
- 4 Davey, Peter. "Good Offices," The Architectural Review, 181:32-85, May, 1987.
- 5 DeNervi, Don. "Masters of Light: Frank Lloyd Wright," AIA Journal, 68:63-65, September, 1979.
- 6 Hertzberger, Herman. "Building Order," VIA, 7:38-45, 1984.
- 7 Hill; Burt; Kosar; Rittelman. "Step by Step Guide to Daylighting Design," Architectural Technology, 36-51, Fall, 1983.
- 8 Meyers, Marshall, AIA. "Masters of Light: Louis Kahn," AIA Journal, 68:60-62, September, 1979.
- 9 Peters, Richard C., AIA. "Masters of Light: Alvar Aalto," AIA Journal, 68:53-55, September, 1979.
- 10 Smith, Herbert L. "Building Types Study 634: Low-and mid-rise office buildings," Architectural Record, 174:85-103, November, 1986.
- 11 Sobin, Harris. "Masters of Light: Le Corbusier," AIA Journal, 68:56-59, September, 1979.

BOOKS

- 1 Bednar, Michael J. The New Atrium. New York: McGraw Hill Book Company, 1986.
- 2 Billington, David P. Robert Maillart and the Art of Reinforced Concrete. Massachusetts: The MIT Press, 1990.
- 3 Calatrava, Santiago. Santiago Calatrava: Engineering Architecture. Birkhauser Verlag Basel, 1990.
- 4 Evans, Benjamin. Daylight in Architecture. New York: McGraw Hill, 1981.
- 5 Huxtable, Ada Louise. Pier Luigi Nervi. New York: George Braziller, Inc., 1960.
- 6 Imbes, Giuseppe; Morandi, Maurizio; Moschini, Francisco. Riccardo Morandi: Innovazione Tecnologia Progetto. Rome: Gangemi Editore, 1991.
- 7 Konz, Stephen. Work Design. Columbus: Grid Inc., 1979.
- 8 Lam, William M.C. Sunlighting as Formgiver for Architecture. New York: Van Nostrand Reinhold Company, 1986.
- 9 Martienssen, Heather. The Shapes of Structure. London: Oxford University Press, 1976.
- 10 Morandi, Ricardo. The Concrete Architecture of Ricardo Morandi. New York: Praeger Press, 1965.
- 11 Parker, Harry; Ambrose, James. Simplified Design of Concrete Structures. New York: John Wiley and Sons, Inc., 1991.
- 12 Prak, Luning. The Language of Architecture. Netherlands: Mouton & Co., 1968.
- 13 Scruton, Roger. The Aesthetics of Architecture. London: Meuthuen & Co., Ltd., 1979.

**The vita has been removed from
the scanned document**