

EVOLUTION OF A SITE

By

Louis Conway, Jr.

Thesis submitted to the Graduate Faculty of the  
Virginia Polytechnic Institute and State University  
in partial fulfillment of the requirements for the degree of

MASTER OF ARCHITECTURE

In

Architecture

APPROVED:

\_\_\_\_\_  
Brown, Chairman

\_\_\_\_\_  
W. Butkr

\_\_\_\_\_  
J. Greenwood

\_\_\_\_\_  
B. Evans

June, 1985

Blacksburg, Virginia

460 7-16-86

ABSTRACT

A highly visible site now separates the two distinct parts of the Radford University campus. Up until twenty years ago the site was an active portion of a Norfolk & Western Railroad switching and storage yard. It presently sits overgrown and obsolete.

Part I of this thesis examines the site, its relationships to the campus it separates, the community, and its own industrial history and nature. A schematic design solution will be proposed. Its goal will be to once again make the campus whole and to acknowledge and strengthen these relationships.

Part II will examine in detail one element of the design solution, an element which will not only be part of a university campus, but part of a journey, part of a destination, and a response to the theme of this thesis - the new and emerging life blood of a community develops among the ruins of the old.

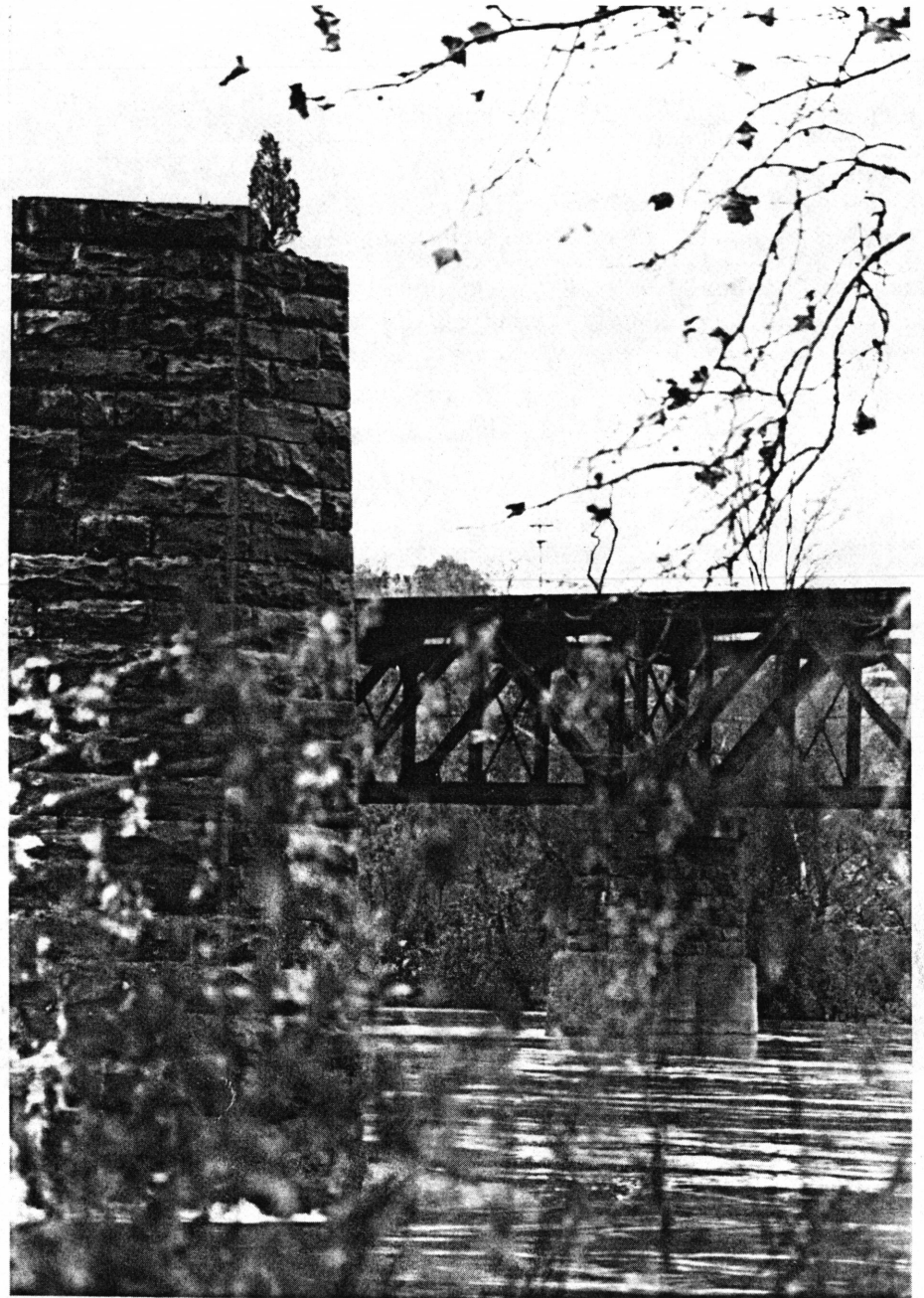

EVOLUTION OF A SITE

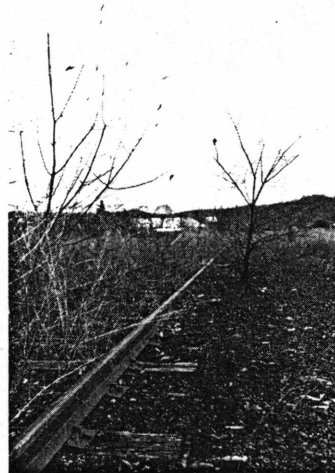

PART I

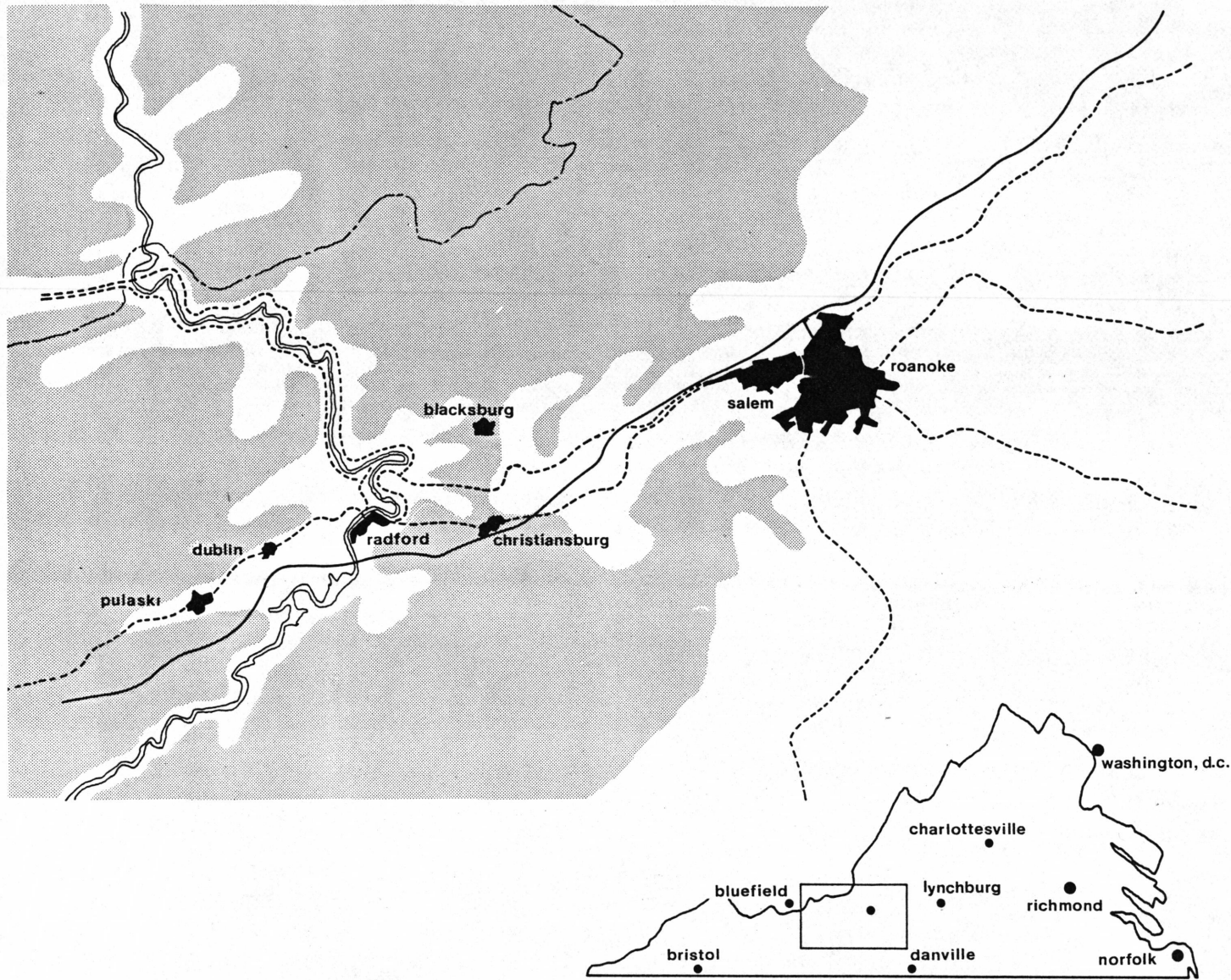

The small settlements of western Virginia in the early 1800's were established as easterners looked for richer and more abundant land to homestead. The New River Valley became important to travelers heading further west as a convenient place to cross the Appalachian Mountains and the New River. Later in the century the railroads came to the valley for their crossings to access developing coal fields in Virginia and West Virginia as well as to continue serving westward expansion.

The place chosen by the railroad as their final regrouping point before the difficult mountain crossings was Radford. The southern banks of the New River in this area provided a substantial amount of flat, developable land above the flood plain and several manageable places where the railroad could cross the river.

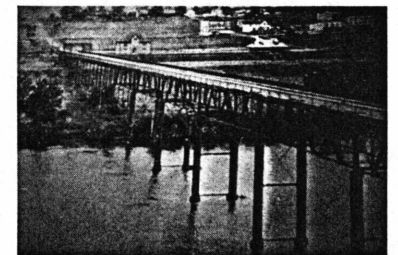
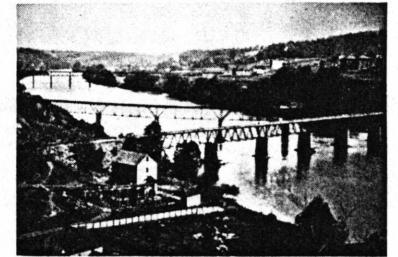

As the 20th Century saw the shift in emphasis from railroads to highways the valleys of the New River remained the channels through which these new arteries carried the economic blood of the nation.

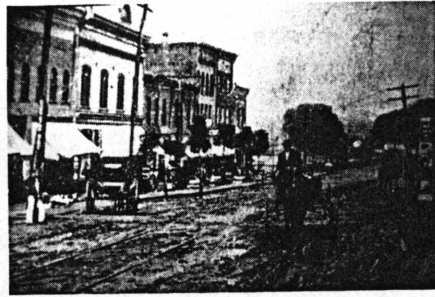

As railroads and highways stretched through the Valley they brought with them industry and services, an added economic base which later would prove invaluable as the railroads declined in importance after WWII. One of the services which established itself in Radford around the turn of the century was a small women's teaching college. A local family donated land adjacent to downtown and the N&W yards to be developed as the new school.

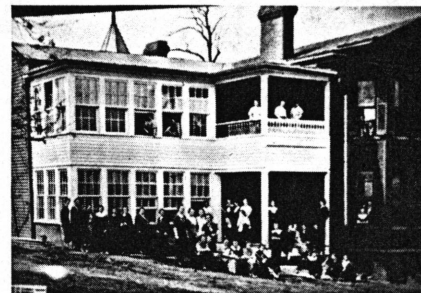



During the 40's the railroad carried as many as 10 trainloads of passengers through the Radford train station each day. Passenger service to Radford ended in 1972, while the small women's teaching college was beginning major steps towards becoming a co-educational liberal arts university.

In the following years Radford University continued to grow while across the street, the railroad died.

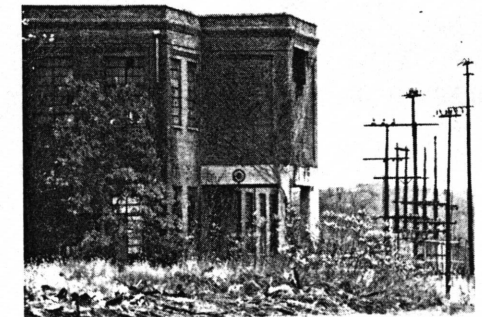
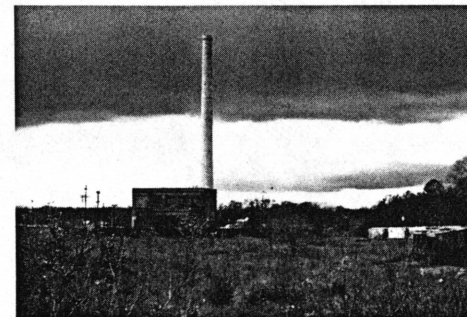
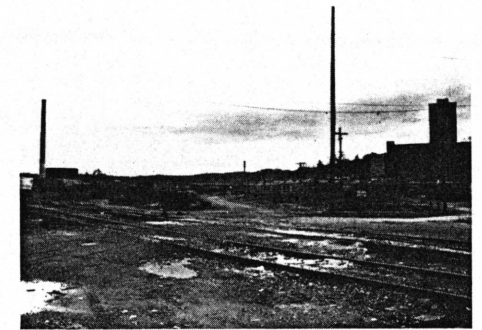
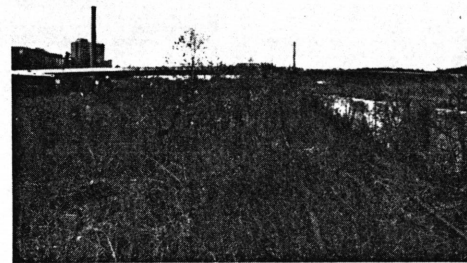
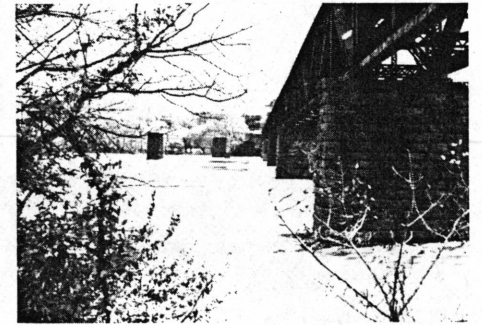
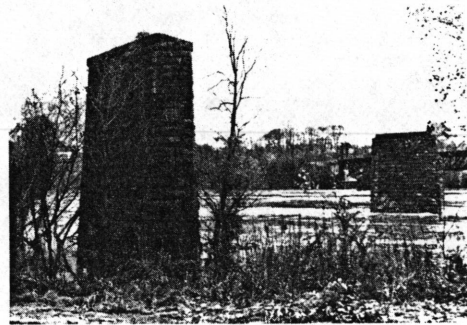
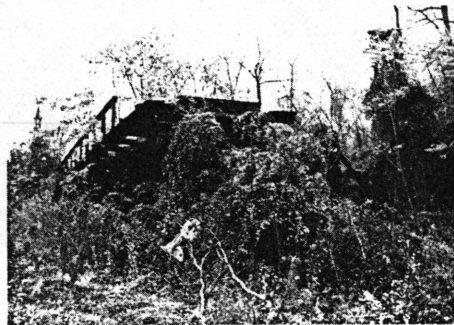

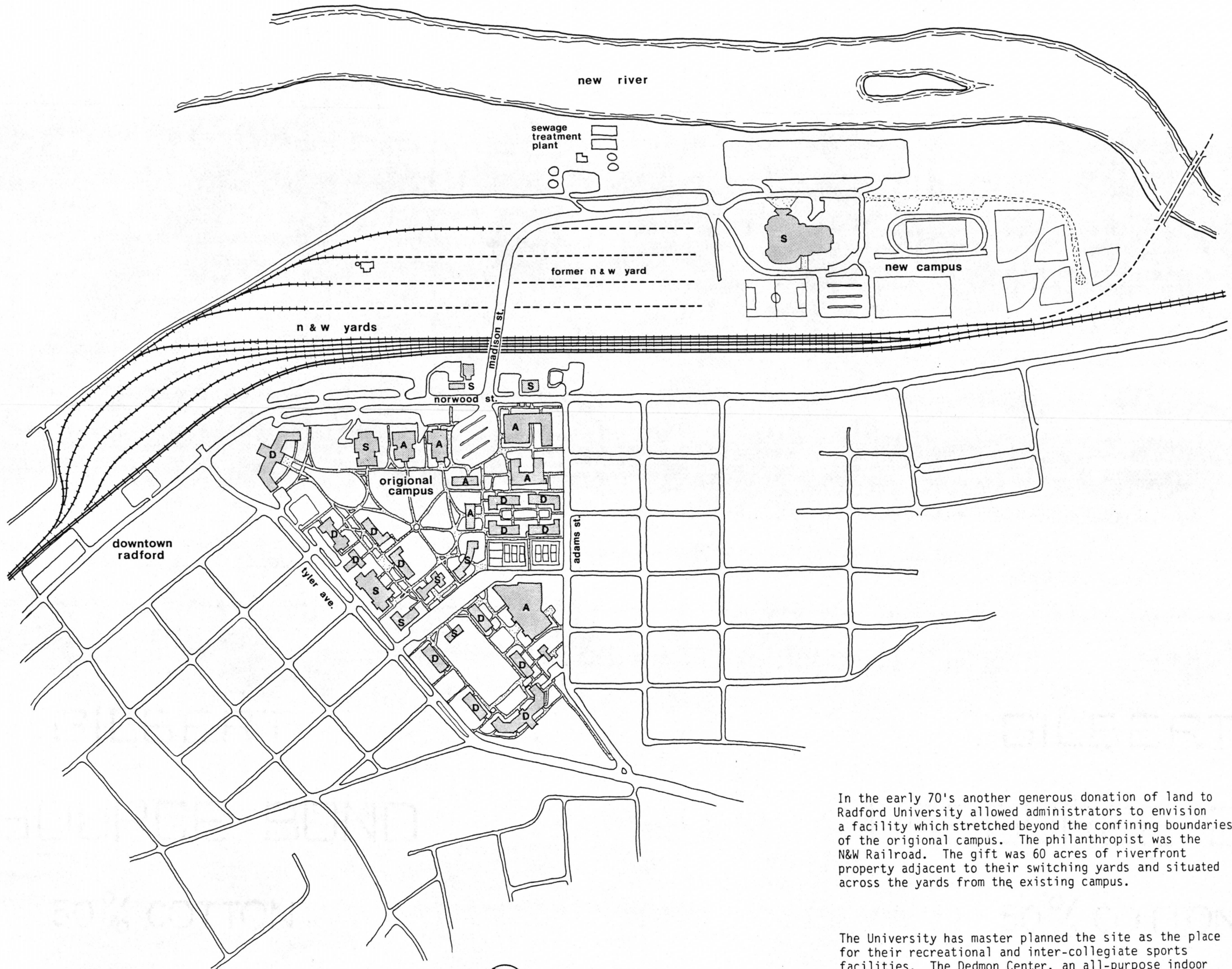

RECENT





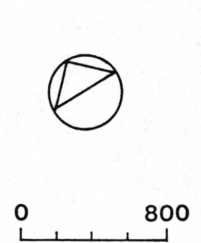
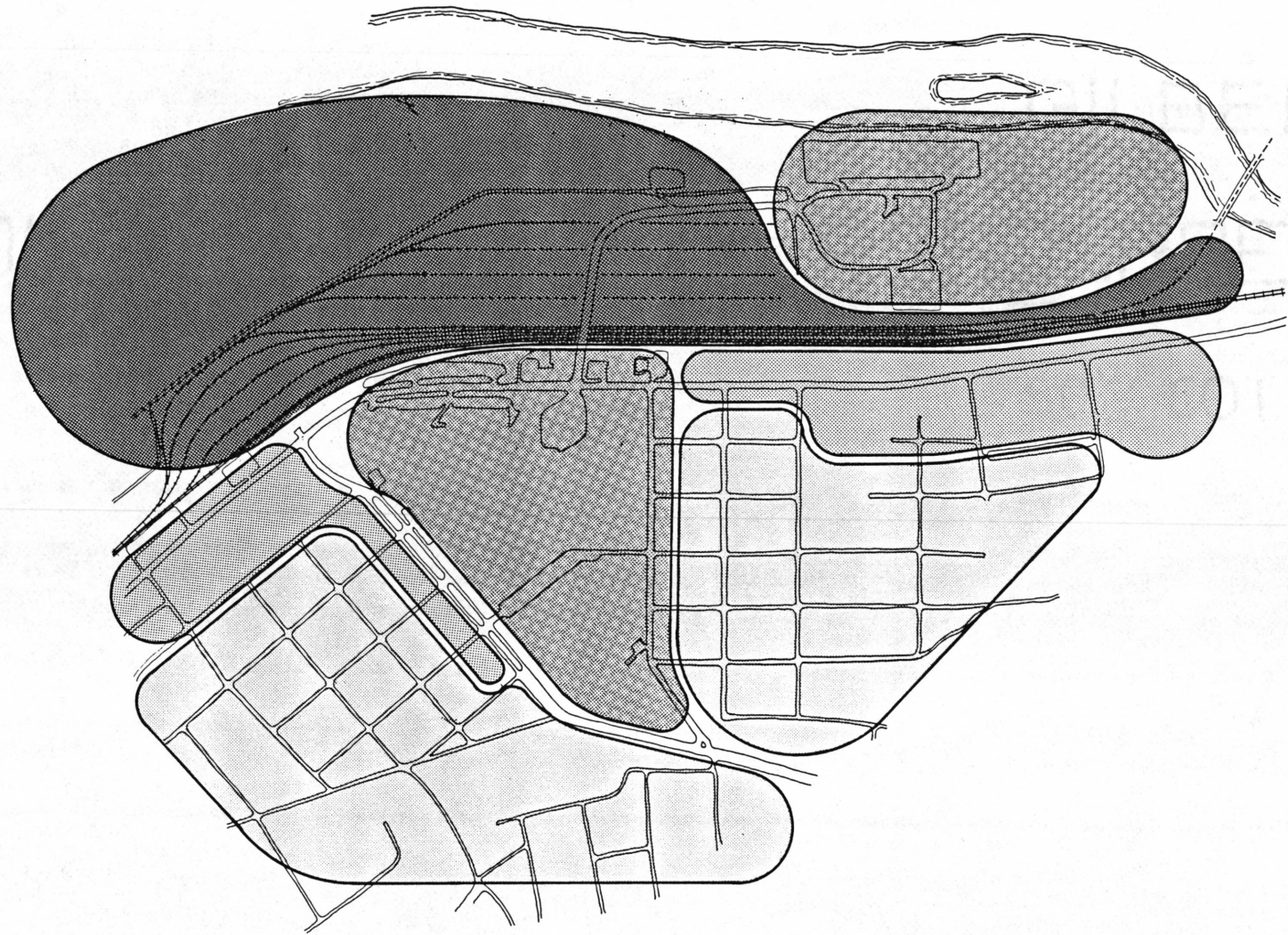
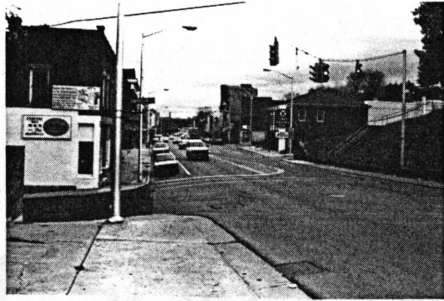

In the early 70's another generous donation of land to Radford University allowed administrators to envision a facility which stretched beyond the confining boundaries of the original campus. The philanthropist was the N&W Railroad. The gift was 60 acres of riverfront property adjacent to their switching yards and situated across the yards from the existing campus.

The University has master planned the site as the place for their recreational and inter-collegiate sports facilities. The Dedmon Center, an all-purpose indoor sports facility is complete with the natatorium and several outdoor sports and recreation facilities under construction. These will be used heavily by students, faculty, and other university personnel as well as the New River Valley community. A large, four laned viadict has been built across the still active railroad tracks in order to access the site.

-  Walks
-  Campus buildings
- A Academic
- S Support
- D Dormitory



-  Campus - original
-  Campus - new
-  Industrial - railroad yards
-  Commercial
-  Residential

The 6500 students of Radford University share the central business district and residential neighborhoods with the town of Radford. While the students have become an integral part of downtown economic vitality the community also relies heavily on its services. Although some longtime residents remain in the surrounding neighborhoods, the overall character of these residential areas has been heavily influenced by an increasing off campus student population. Downtown and the University alike are bordered on the north by the heavy industrial band that is the railroad yards, separating these areas from the riverfront.

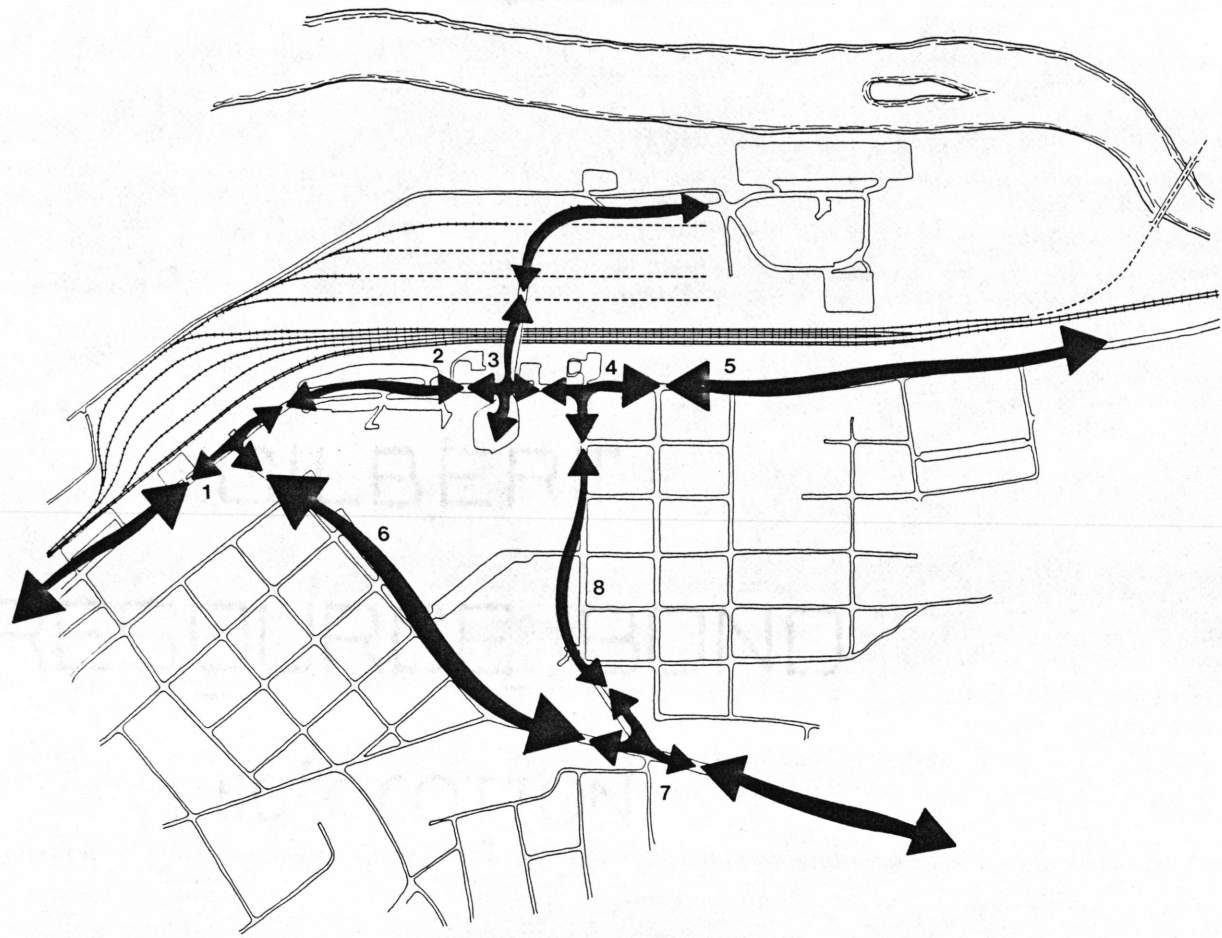

0 800

PRIMARY VEHICULAR TRAFFIC

1.



2.



3.



4.

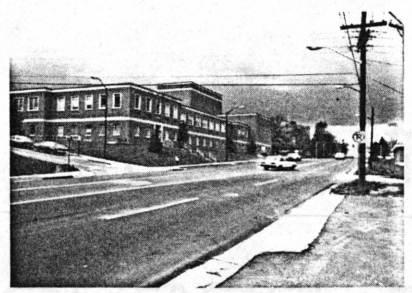

5.

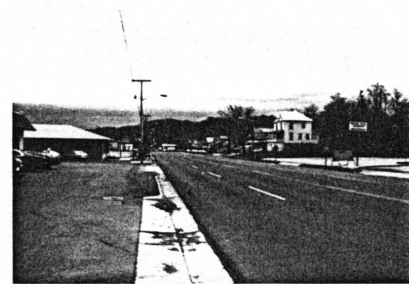

6.



7.



8.

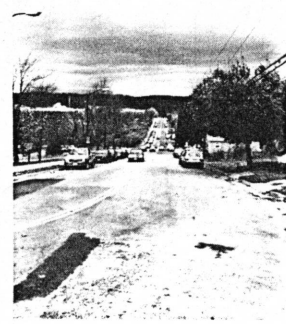

Radford University's original campus is extremely convenient to concentrations of housing and downtown businesses, making it largely a pedestrian and bicycle environment.

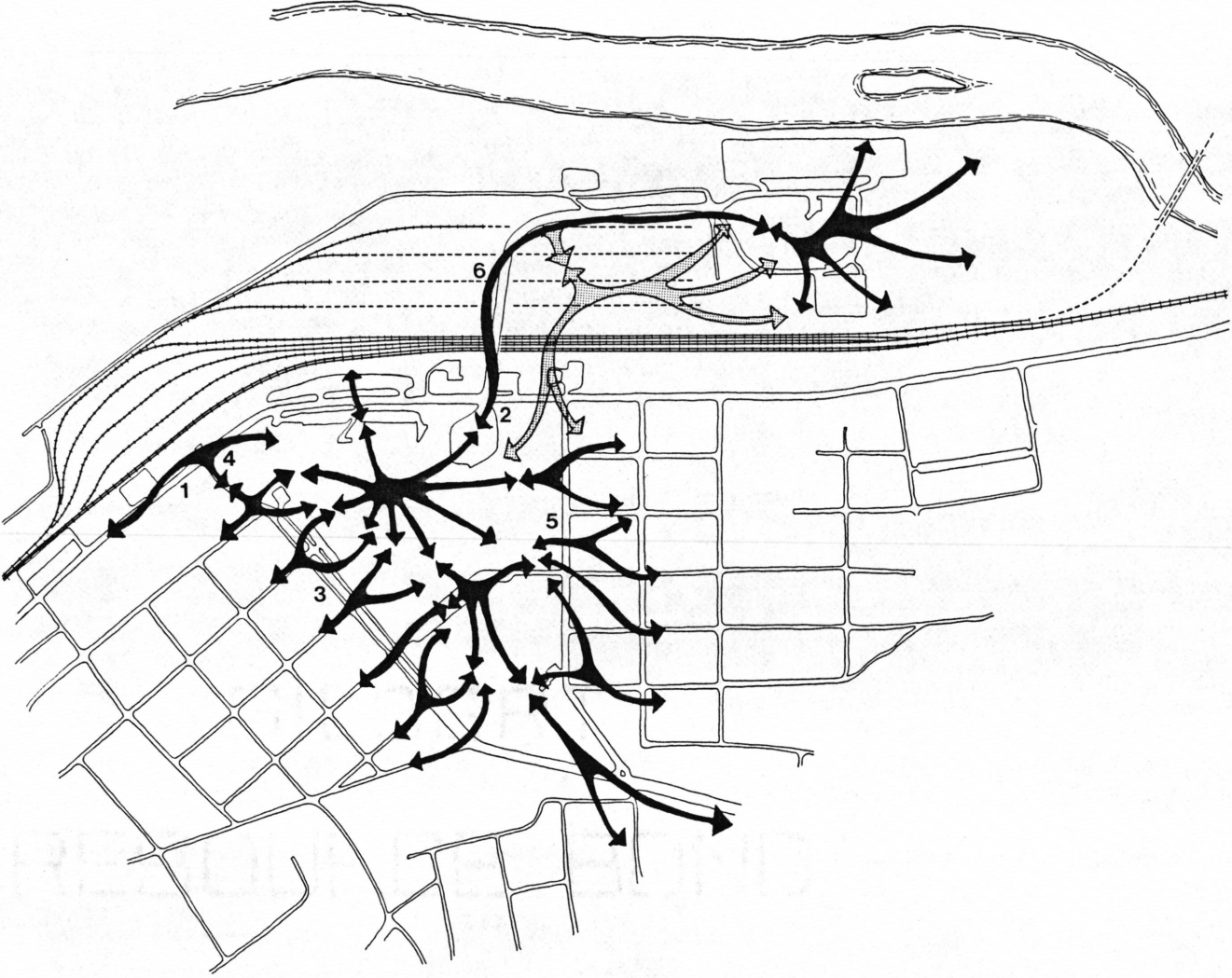

1. Norwood Street is the vehicular and pedestrian core around which the central business district of Radford is organized and made accessible. Downtown stops at the Tyler Avenue intersection and that portion of Norwood Street forming the base, or northern edge of the triangular shaped campus is largely devoid of any pedestrian traffic.
2. The tree-covered parking lot at the intersection of Norwood Street and the Madison Avenue viaduct serves weakly as the University's front door. It is the only established point of orientation for visitors, newcomers and the community in general.
3. Tyler Avenue extends south from Norwood Street and is the western edge of campus. It serves well as a buffer, a secondary business district, a neighborhood feeder street and as the primary route to and from Interstate 81.
4. The intersection of Tyler Avenue and Norwood Street is the most visible and active point of campus for both cars and pedestrians.
5. Adams Street is the third side of the triangle and serves principally as a neighborhood feeder street.
6. Pedestrian access to the Dedmon Center site is the sidewalk of the Madison Street Viaduct.

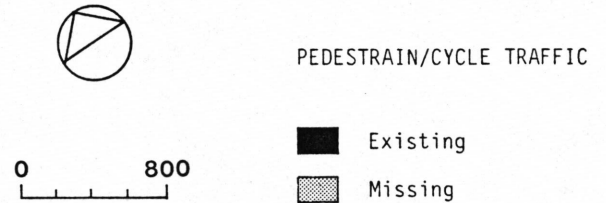

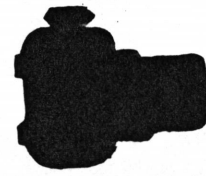

The site separates the old and the new, leaving a pedestrian void in a pedestrian environment. The obsolete railroad yard physically and perceptually detaches university and community alike from a most valuable asset. A narrow sidewalk surrounded by chain link and pavement, continually disappearing from view, serves only to discourage.

But the university and the community owe their existence to the yards, the crossings, and the nature of the site. Design goals will not be to overwhelm and bury, but rather to acknowledge.

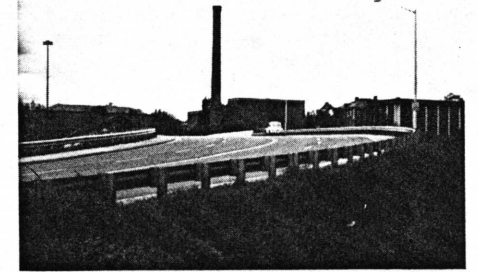
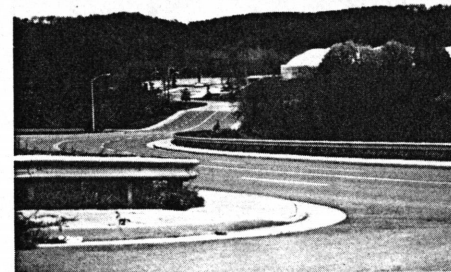
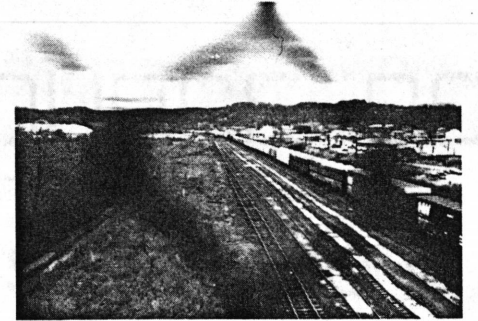

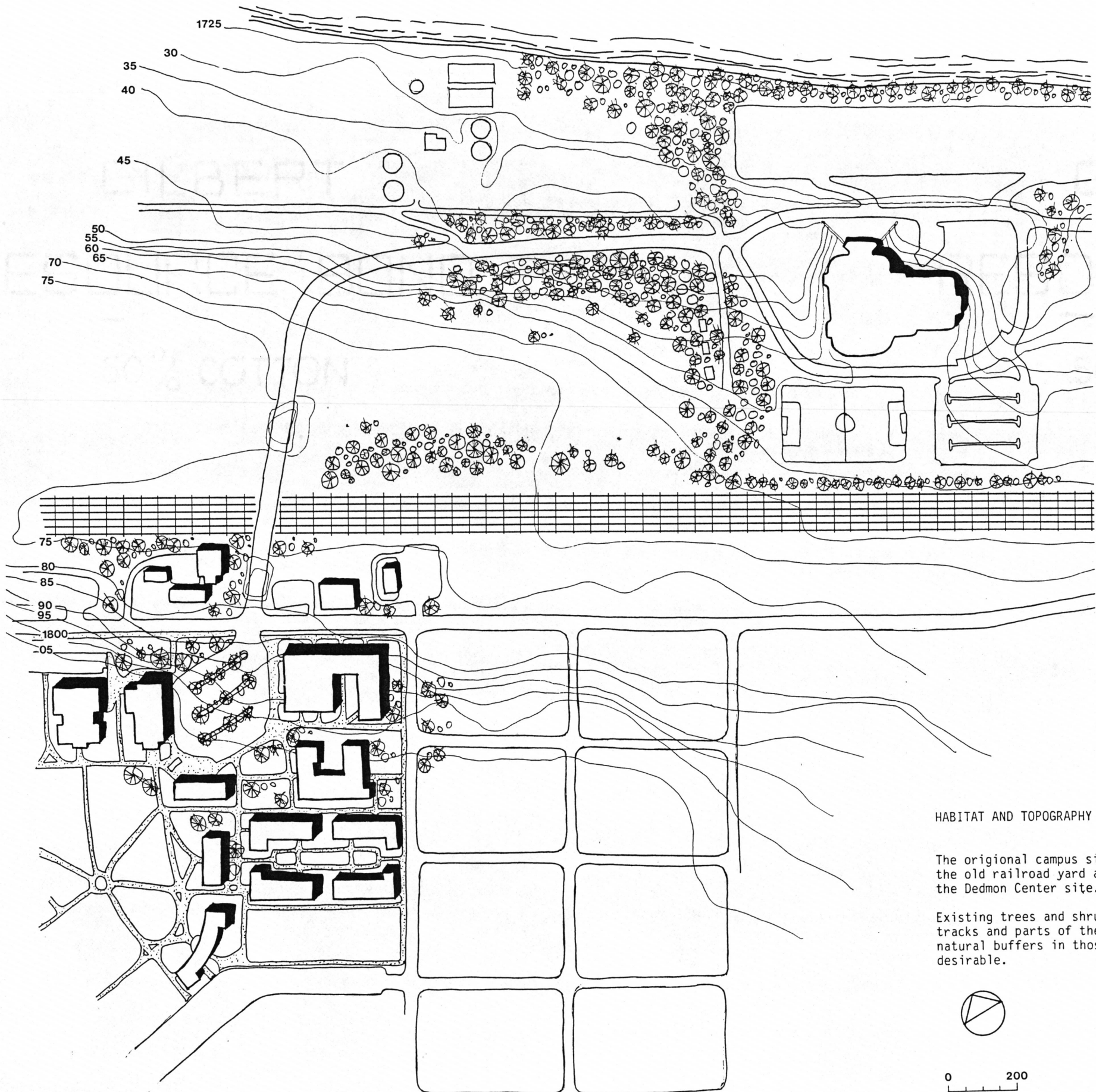

HABITAT AND TOPOGRAPHY

The original campus sits 35 - 40 feet above the old railroad yard and 60 - 70 feet above the Dedmon Center site.

Existing trees and shrubs line the active railroad tracks and parts of the Madison Street viaduct creating natural buffers in those places where they would be desirable.



0 200

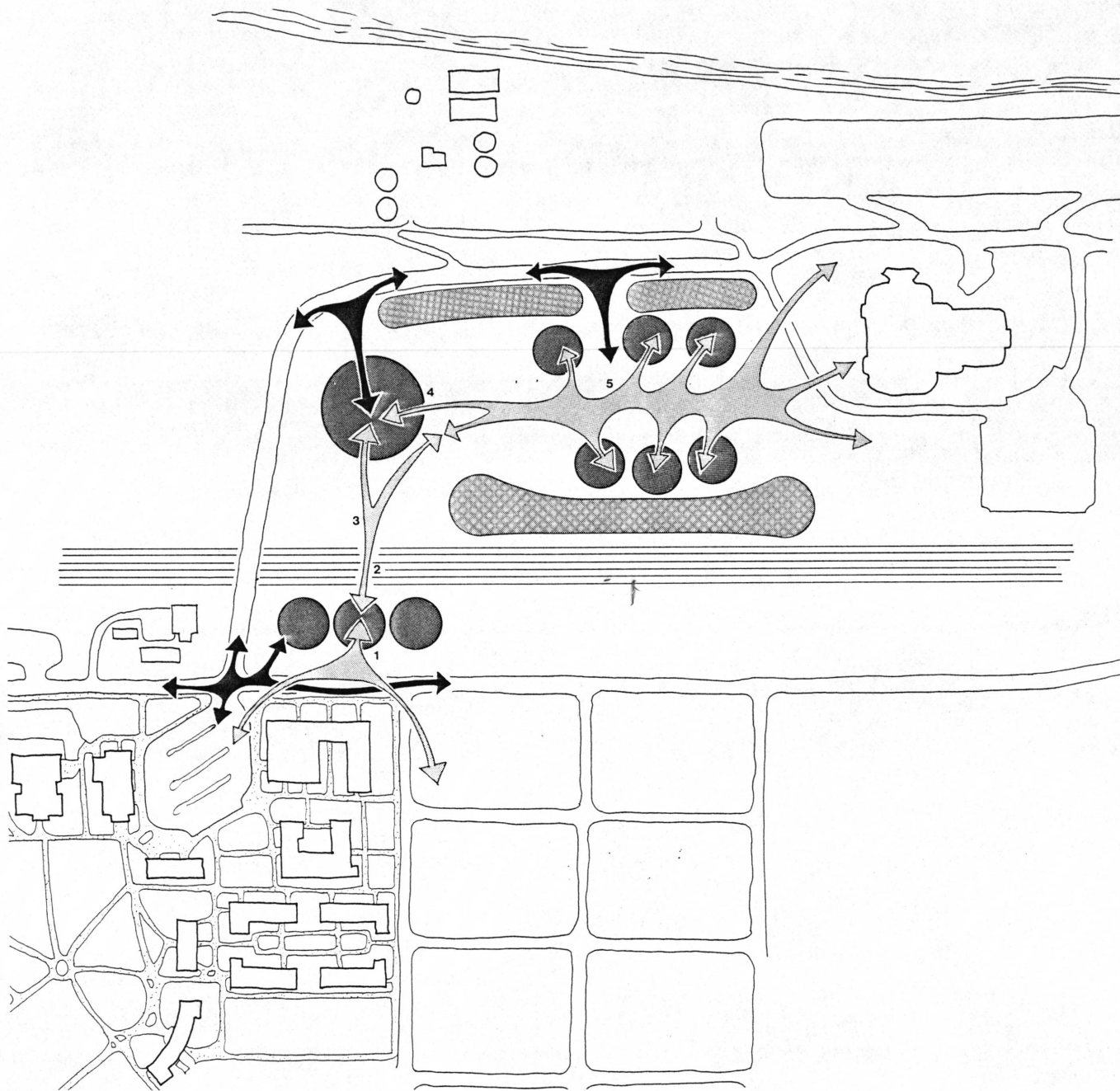

**FUNCTIONAL ANALYSIS**

As well as being a series of places and events, the site should inspire movement and perception; each segment is its own, yet an understood part of a whole. The site should be layered and somewhat transparent to enhance this understanding of the whole through visual reassurances.

1. That portion of the site bordering Norwood Street should serve to strengthen the already established Front Door as a point of orientation. It should function as dignitary while also allowing direct pedestrian penetration, adjacent vehicular movement and access, and as a springboard for crossing the railroad tracks. These same aspects should receive consideration as a two way relationship; the connection from the site to the existing campus across Norwood Street may be the most critical.
2. Crossing the active railroad tracks should remain true to form. Part of a building will become a bridge. The linear nature of the building as a bridge establishes the forms which will connect opposite sides of the tracks.
3. The bridge does not end abruptly. After crossing it is allowed to become something more than a bridge. It once again reaches for the ground in search of a destination and direction. Relationships through physical connection, communication and shared activity are reinforced here.
4. The turn towards the riverfront becomes more an intersection. It is where the bridge meets the old tracks of the railroad yard. If one were to approach this point from the riverfront the eye would be drawn down the overgrown tracks, past the viaduct and finally to the huge smokestack of the yard's obsolete power plant. This intersection should be functionally and perceptually strengthened through spiritual involvement; an urban place which is both structured and informal. Yet as hard and defined as this place is, people should weave through it, around it, to and from it in many inspiring layers.
5. The approach to the riverfront site should serve as a deceleration zone, a transition from student to individual, a dispersal from urban to suburban. At this point one parallels the old rails. They can follow a main line to an anticipated destination or branch off to stop and spend some time, either alone or as part of a small community.
6. Distance, open spaces, landscaping and topography serve to buffer the site from surrounding industrial and vehicular activities.

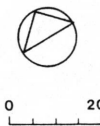

- Vehicular
- Pedestrian/cycle
- Structure
- Buffer

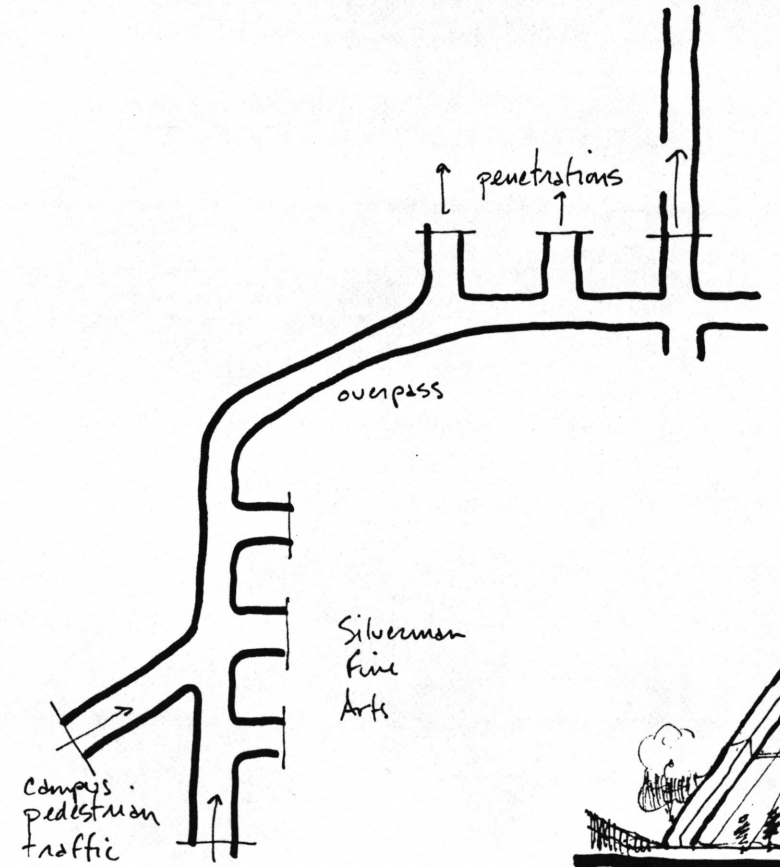
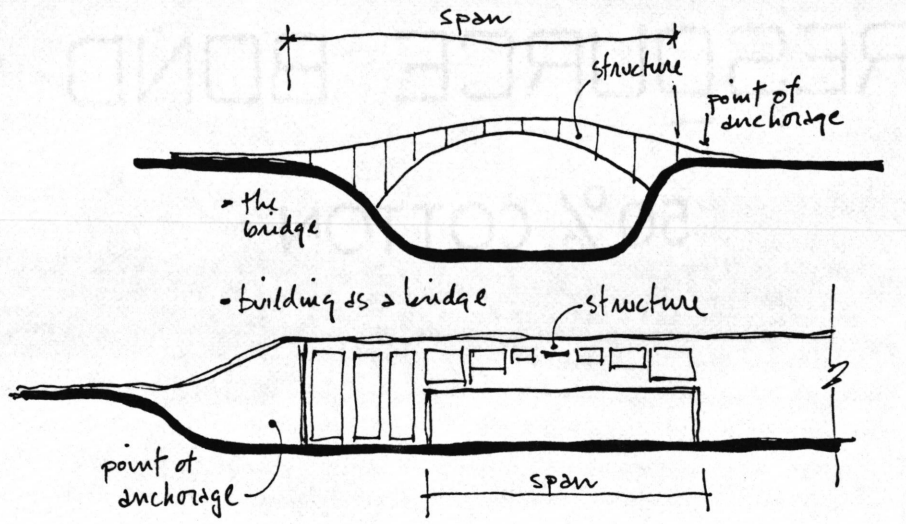
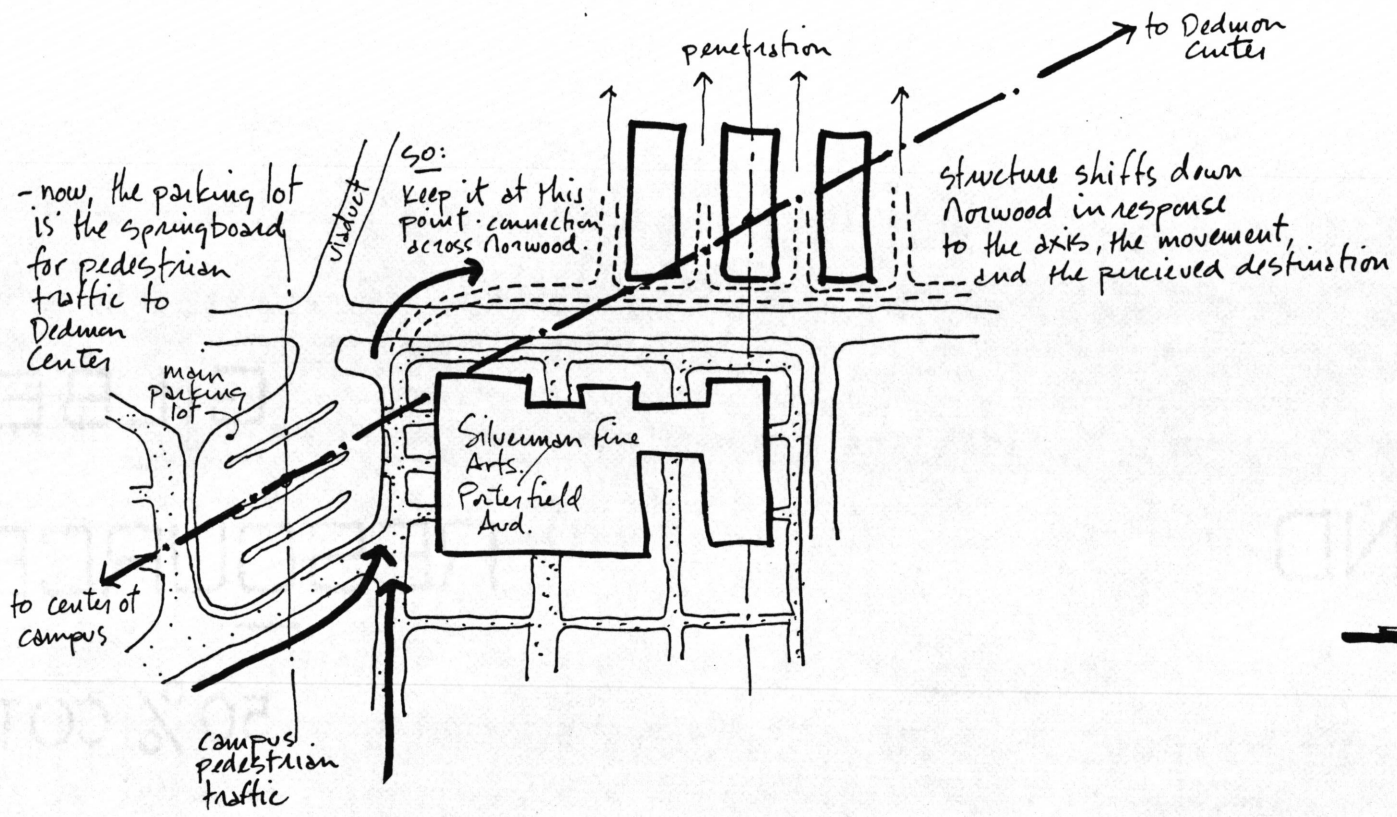

- the dignity? R.U.'s public face
- functionally relates to Silverman Fine Arts on South Side of Norwood St.

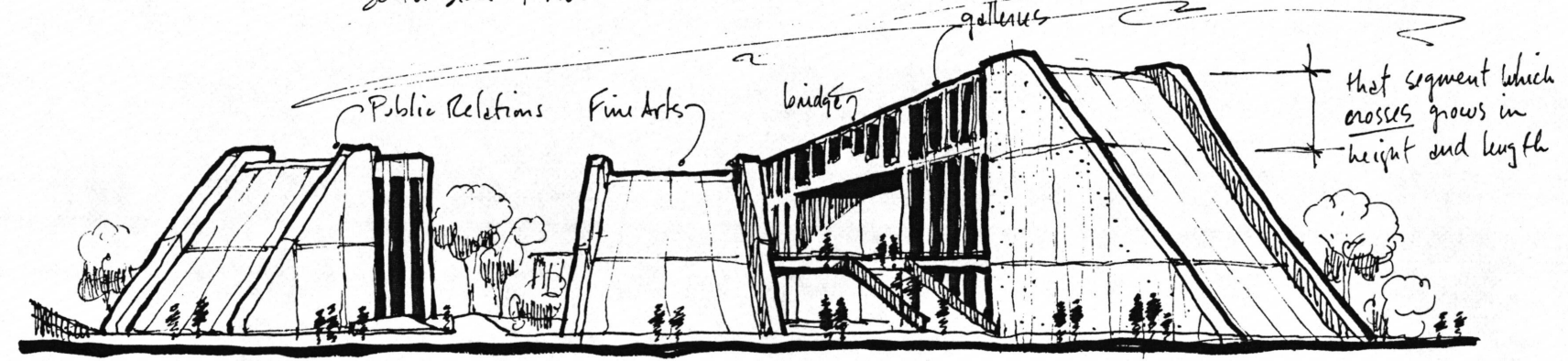

- penetration
  - point of attachment
  - structure
- viewed from Norwood St.

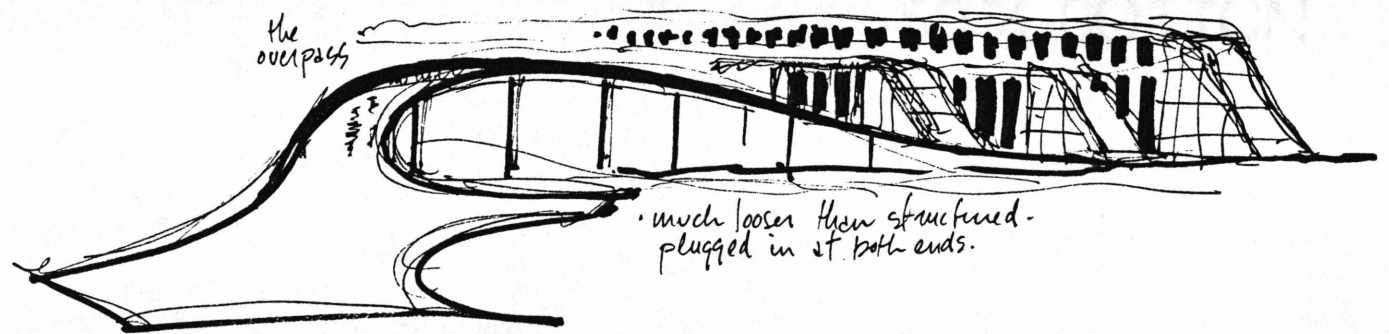
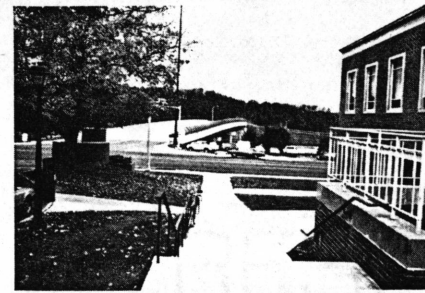
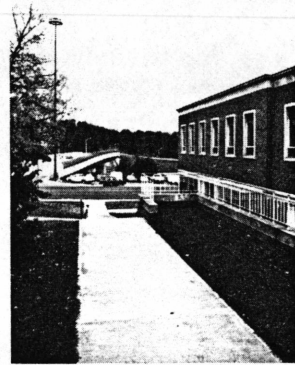
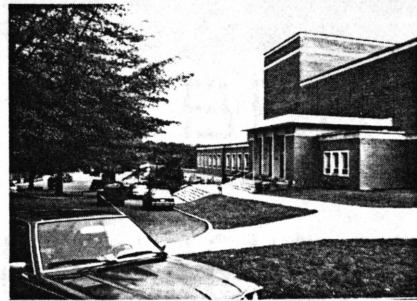

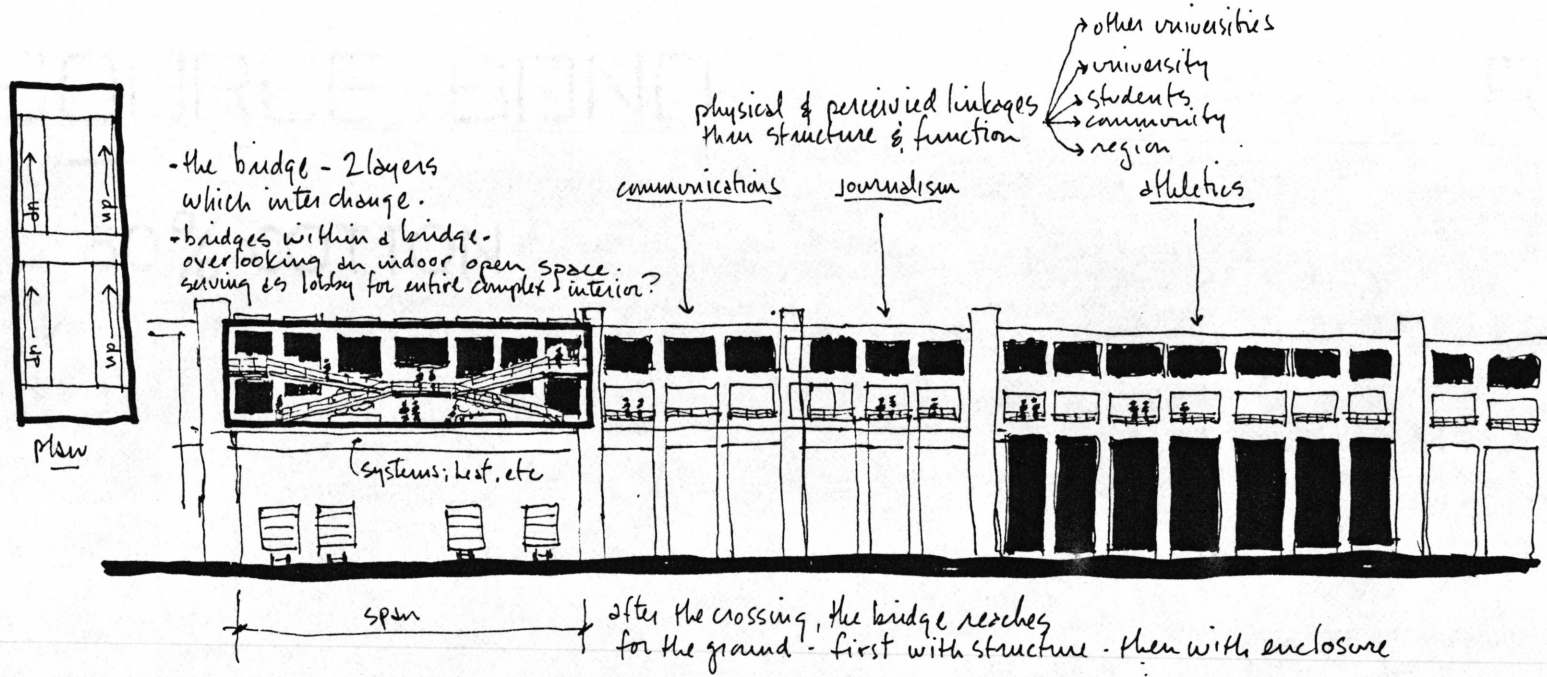

50% COTTON

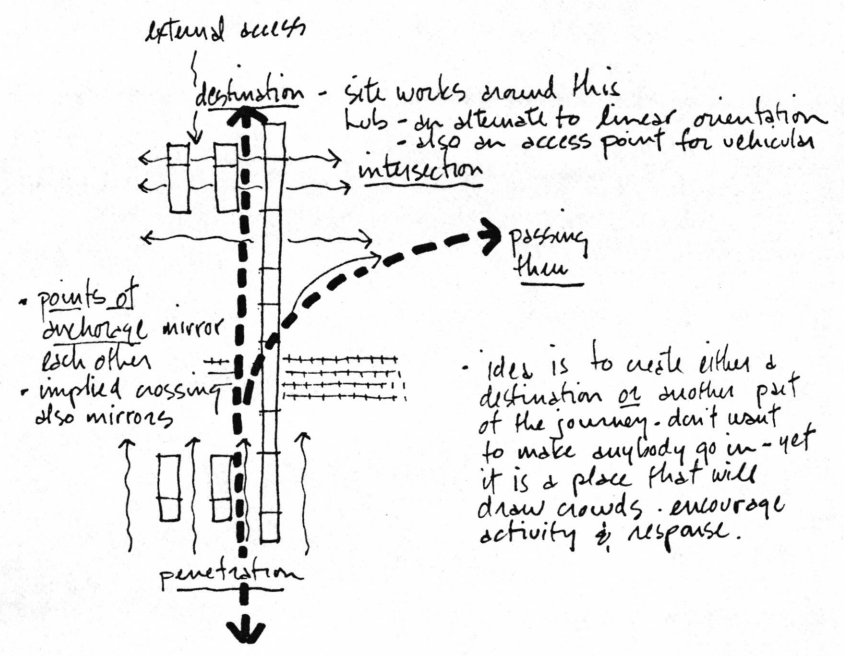
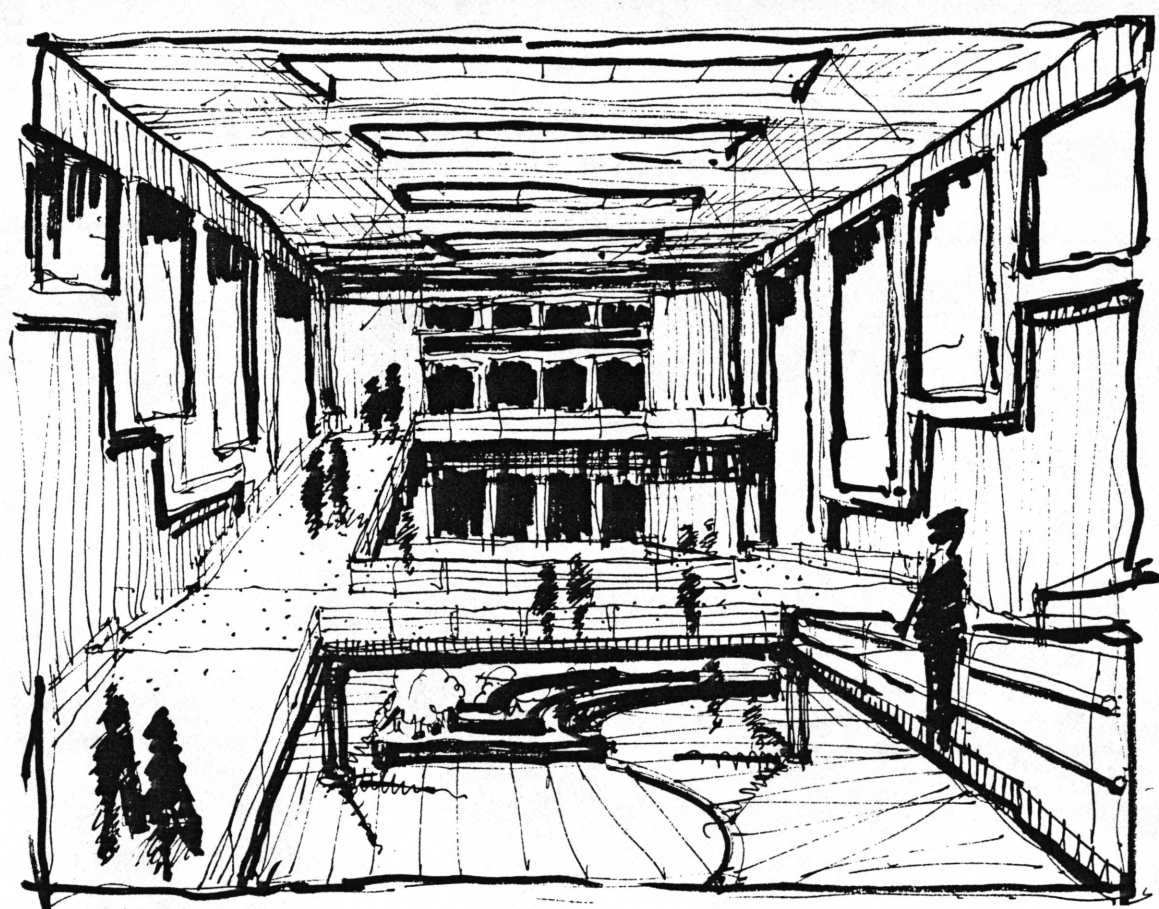

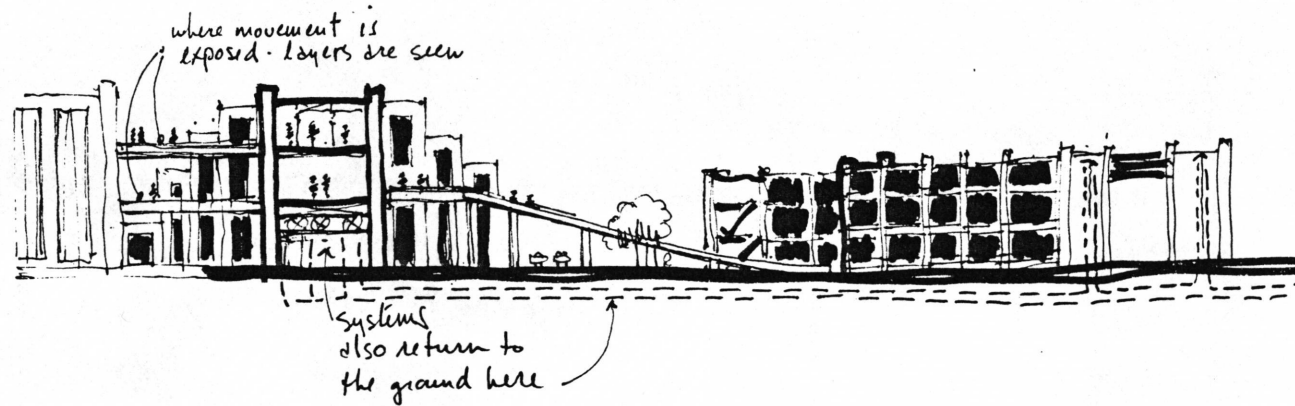
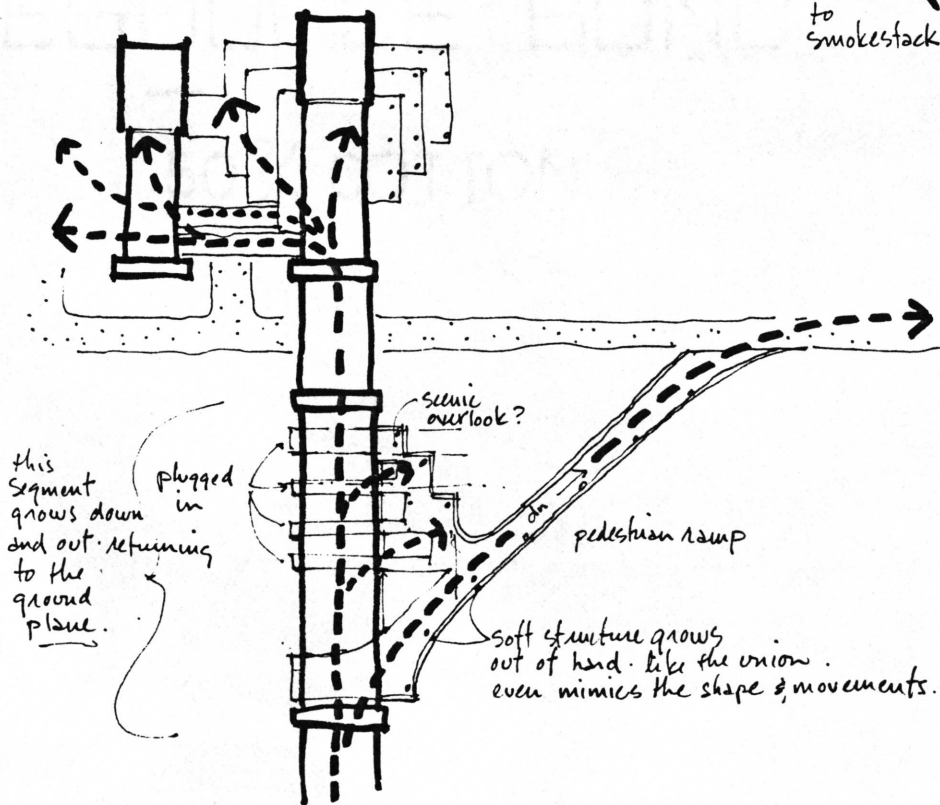
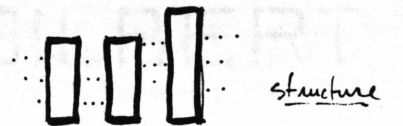
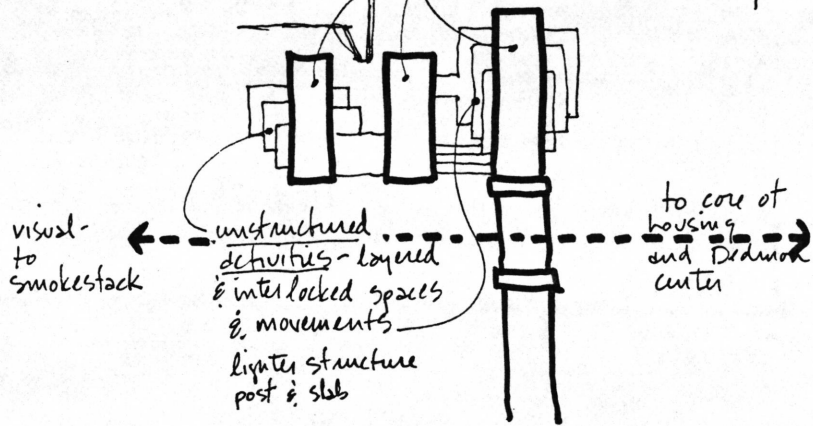
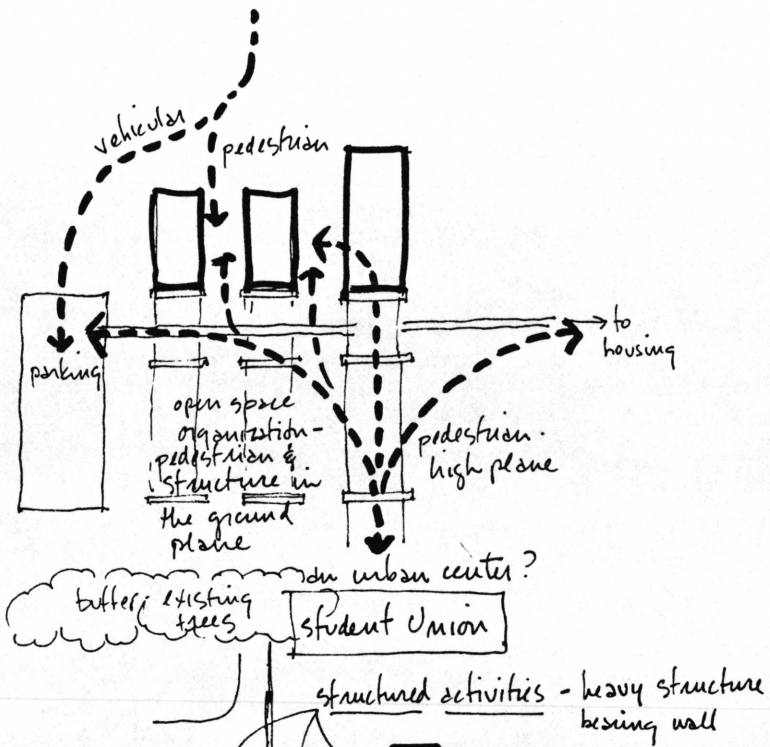
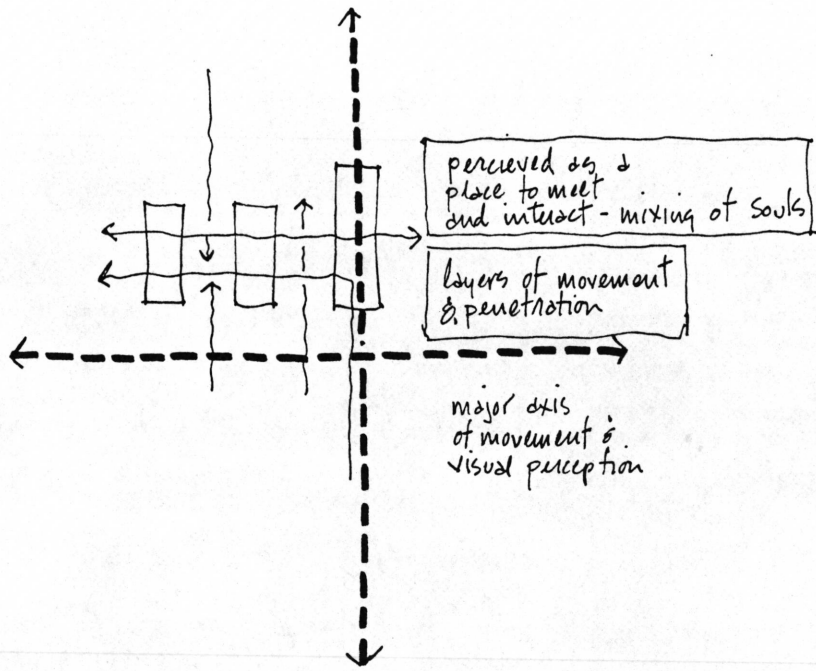

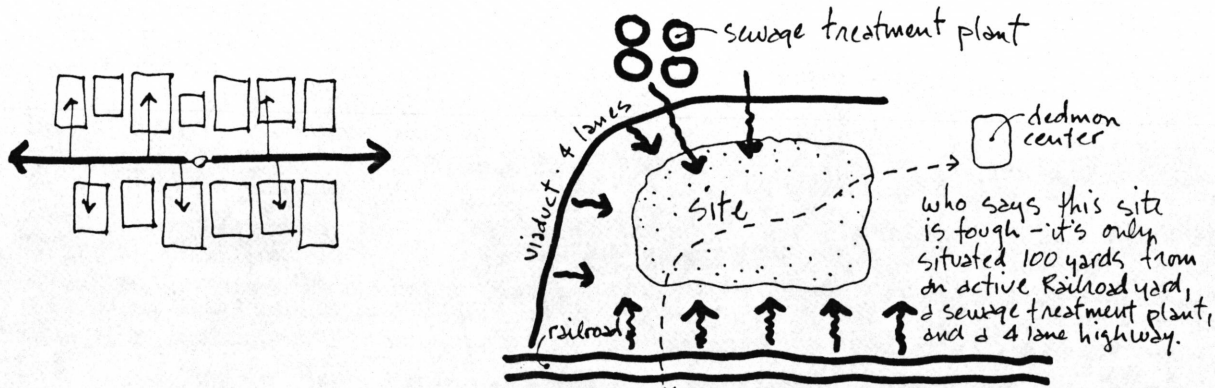

response: housing has an inward orientation. turning its back on those images & activities serving to disturb... while serving to strengthen its community and its core - the open space which serves part time as a pedestrian corridor.

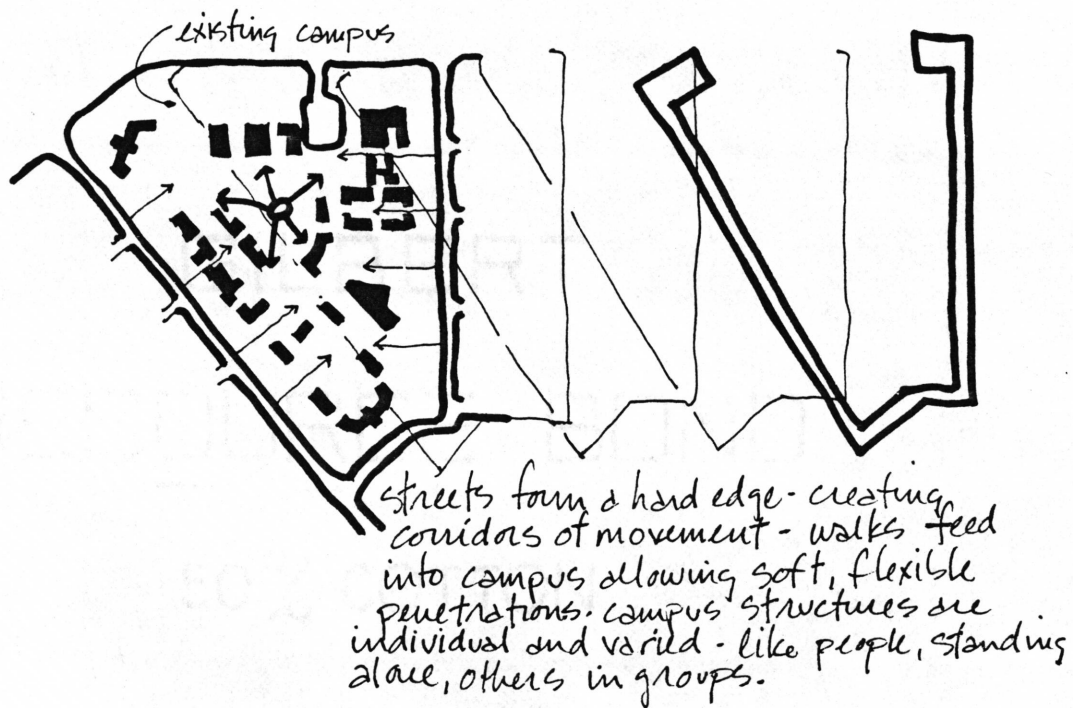
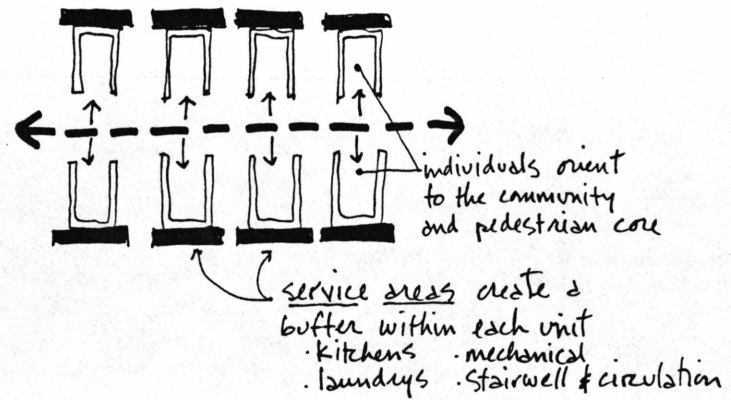

the overall composition has soft and hard parts.  
 to structured ← → to unstructured  
 openings into the site characterize where your going and where you've been.

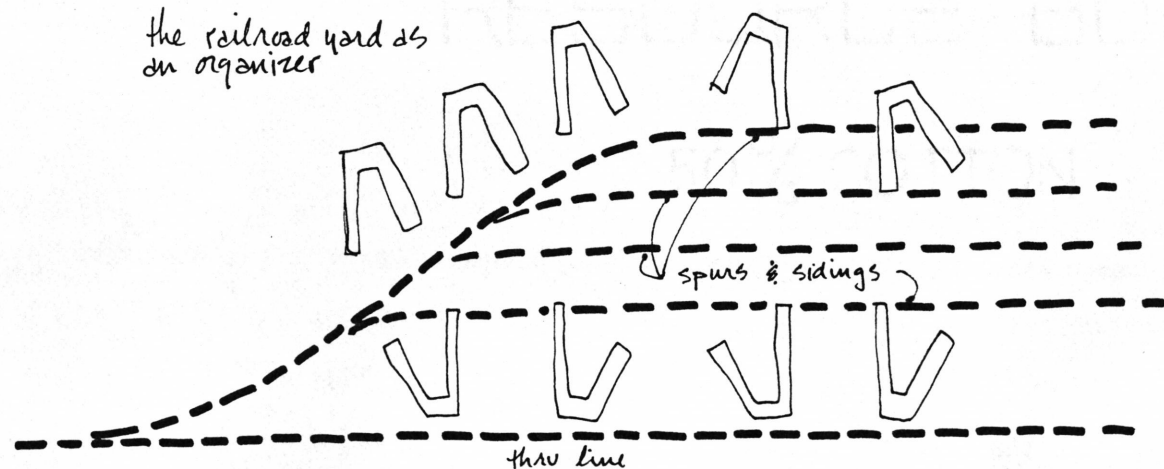

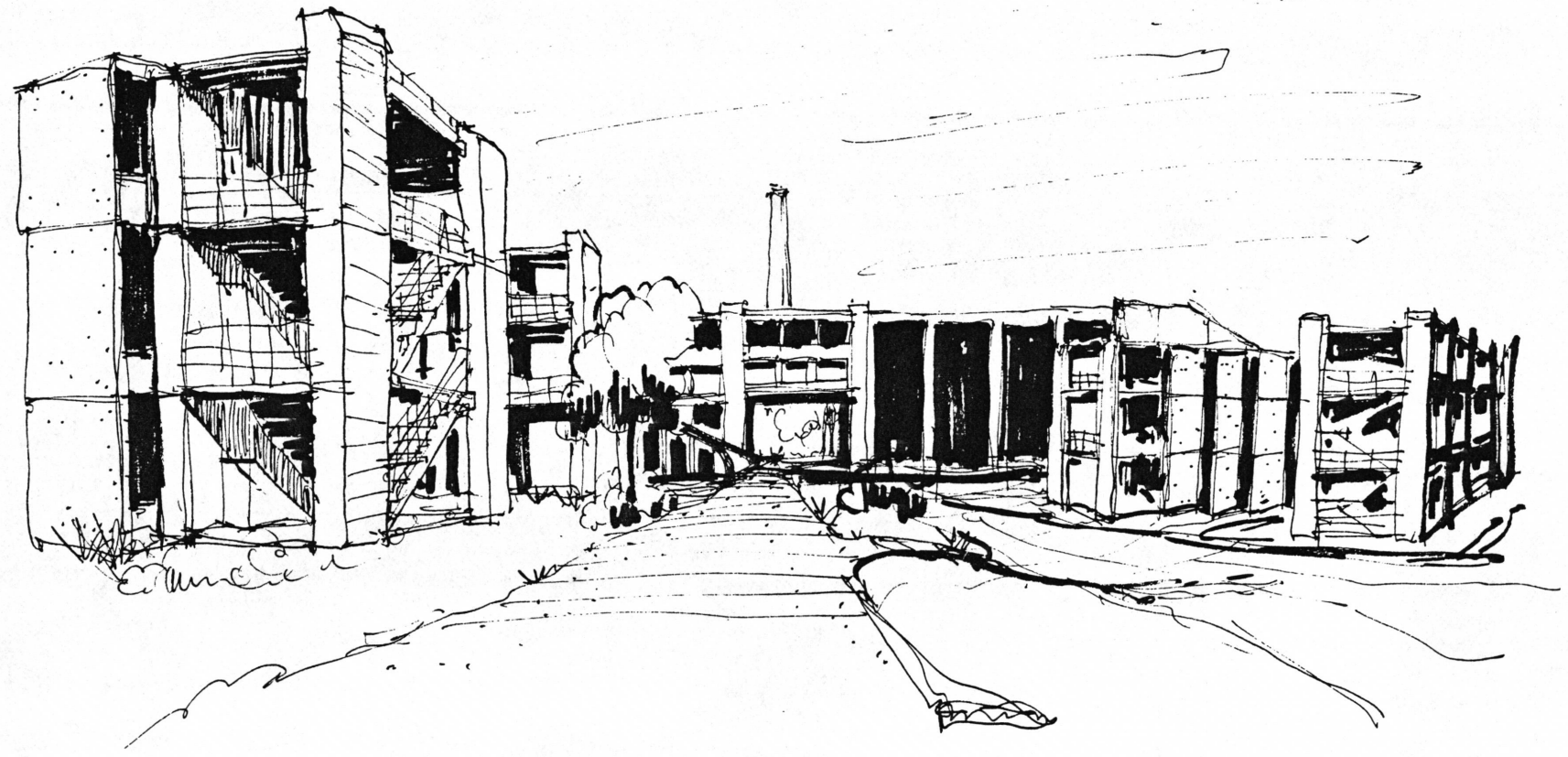
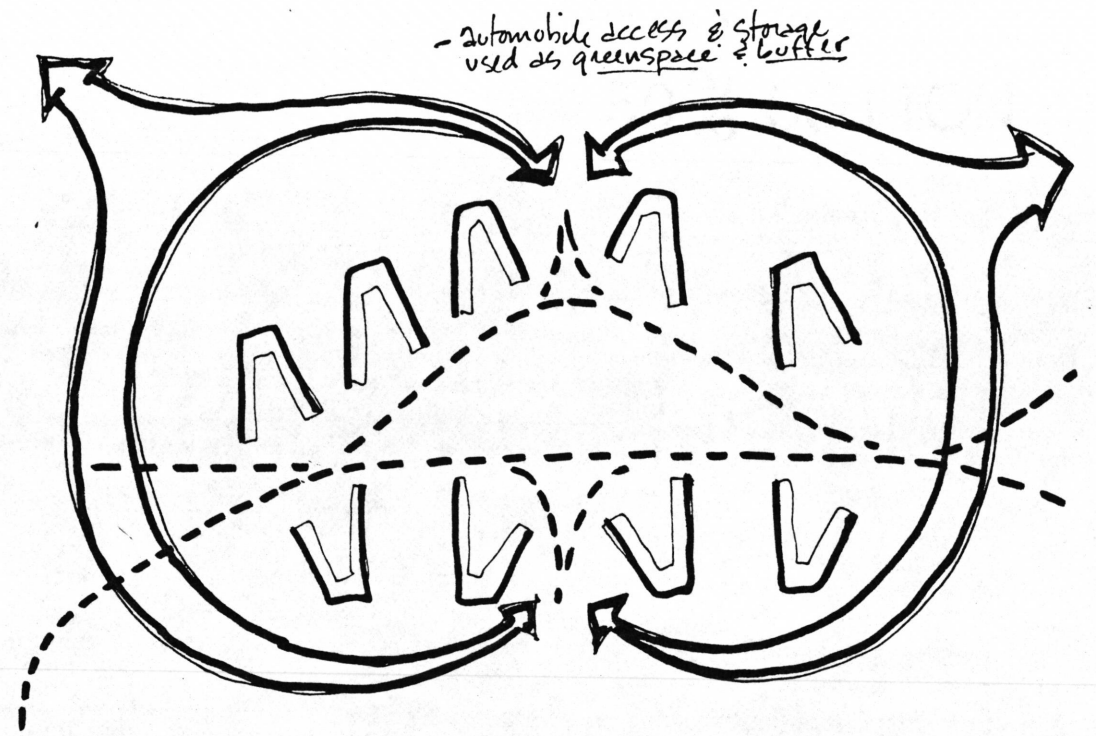
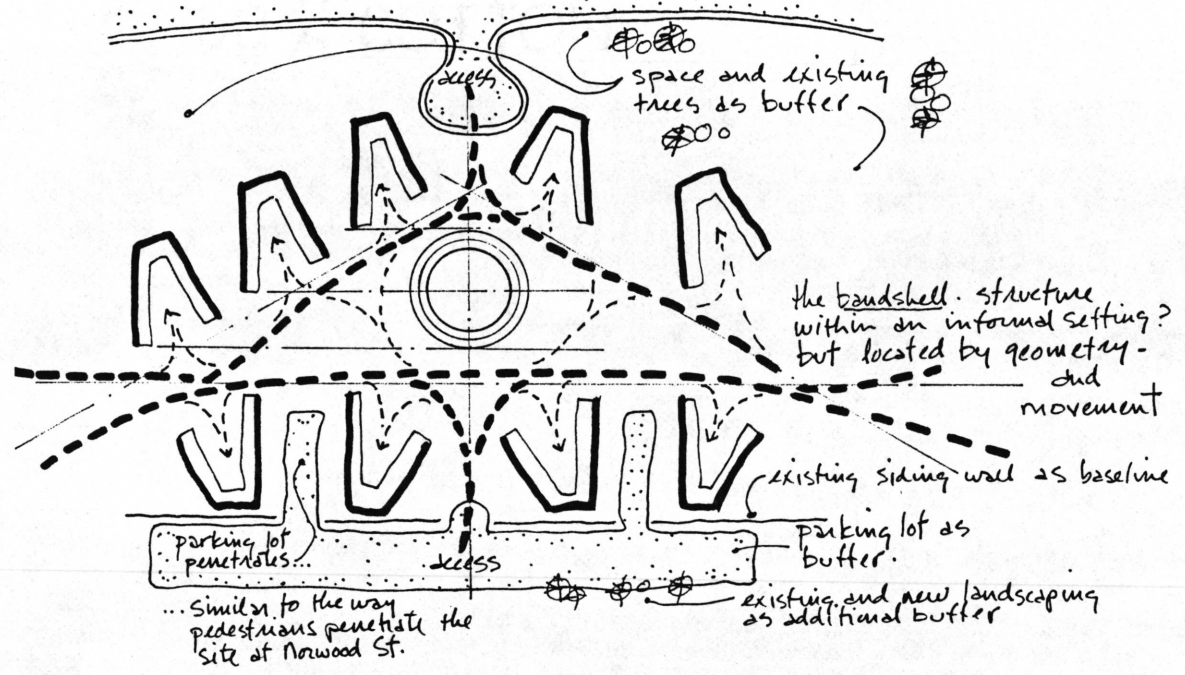

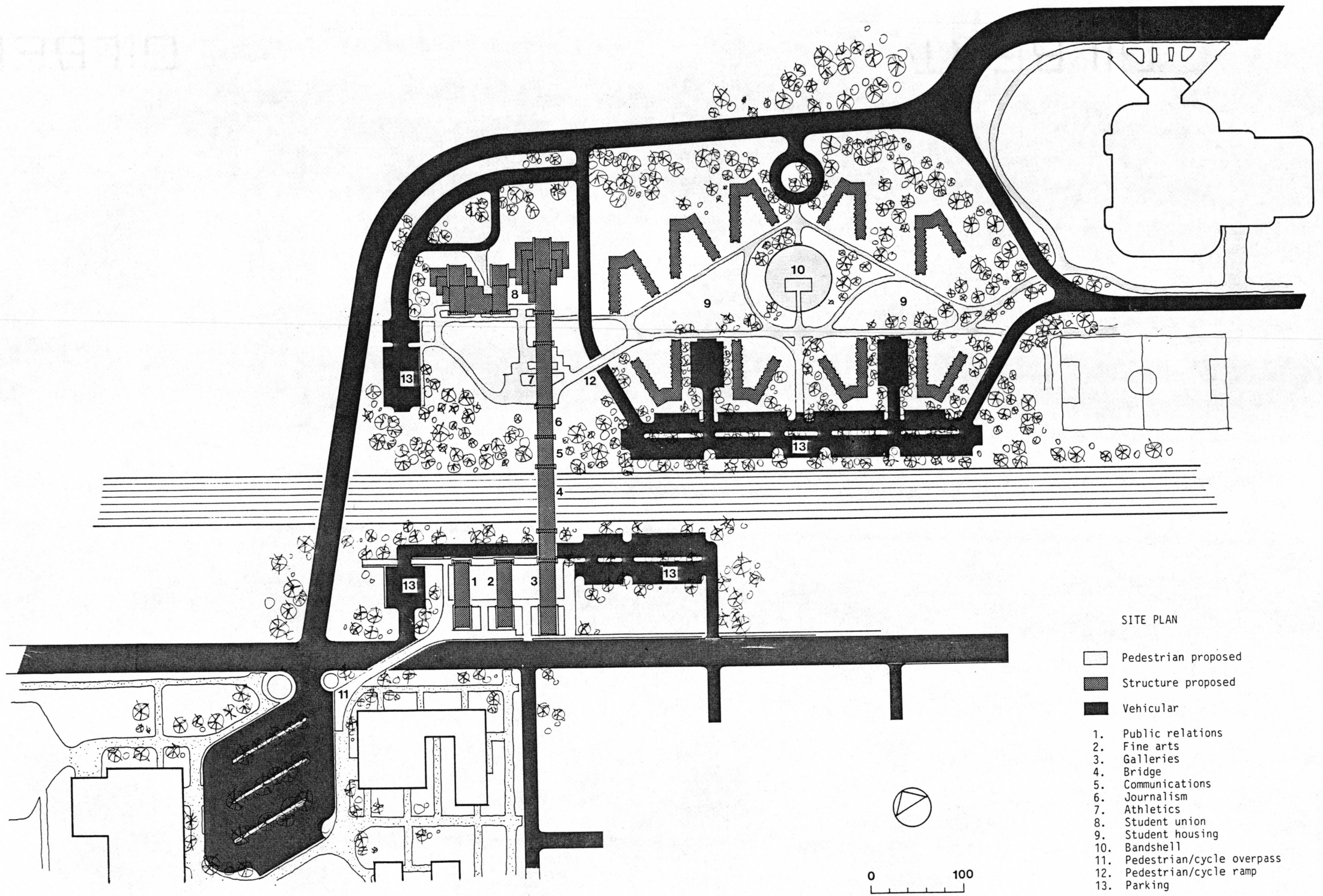

SITE PLAN

- Pedestrian proposed
- Structure proposed
- Vehicular

1. Public relations
2. Fine arts
3. Galleries
4. Bridge
5. Communications
6. Journalism
7. Athletics
8. Student union
9. Student housing
10. Bandshell
11. Pedestrian/cycle overpass
12. Pedestrian/cycle ramp
13. Parking

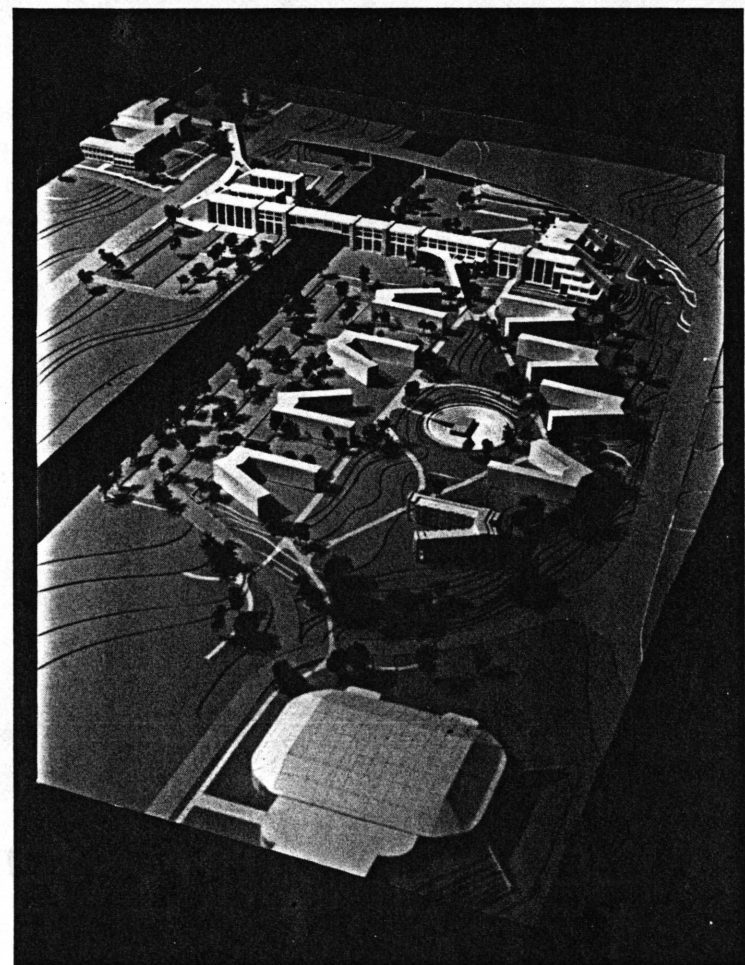
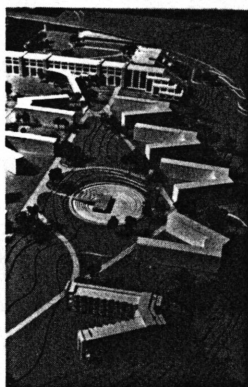
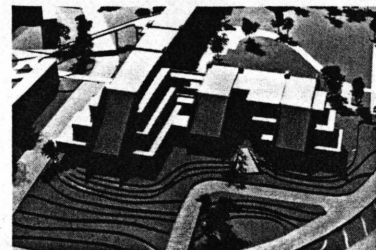
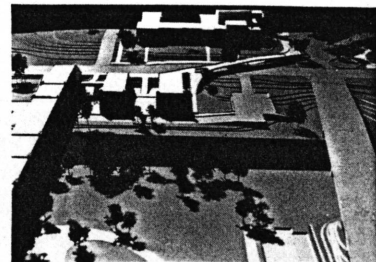
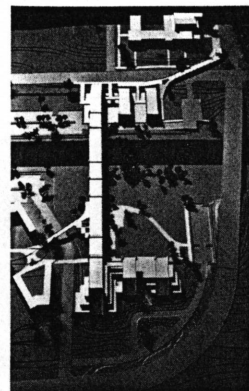
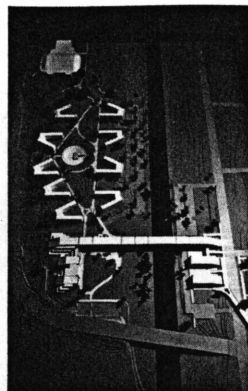
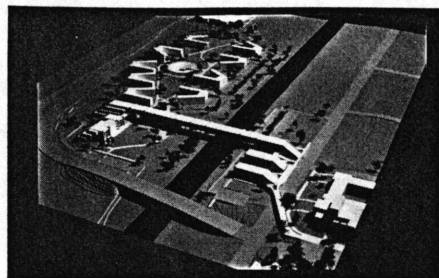

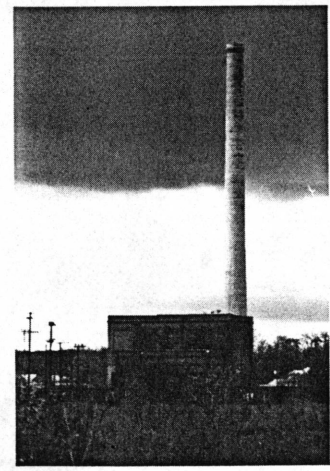
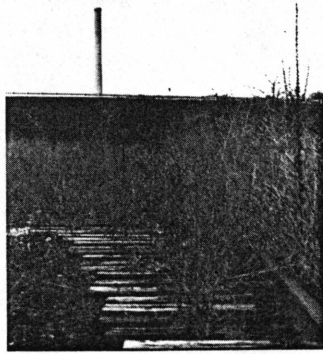
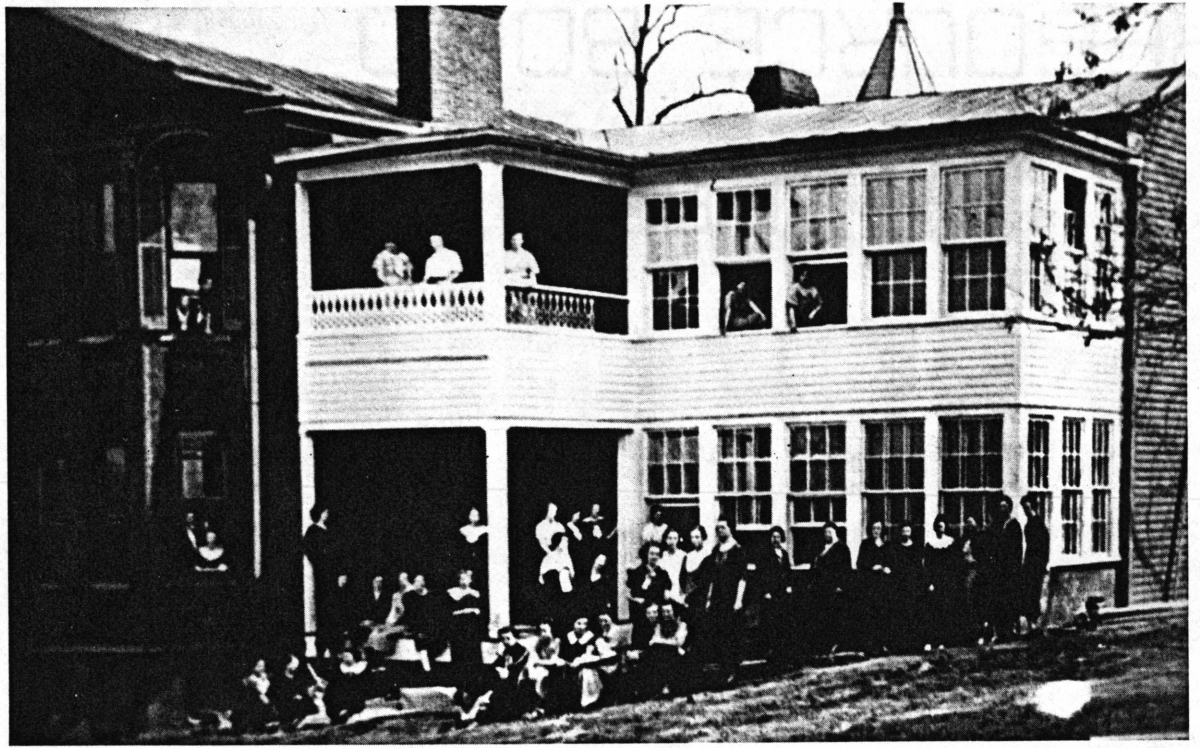

PART II

the industrial nature...  
 systems as another  
 organizer - like a chimney  
 or smokestack - enclosed  
 by structure.

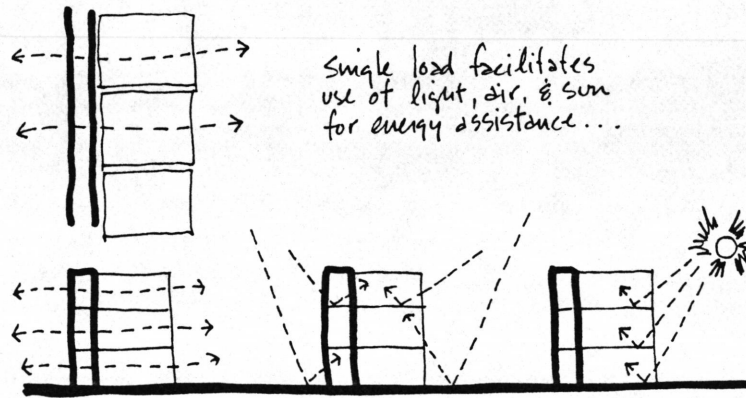
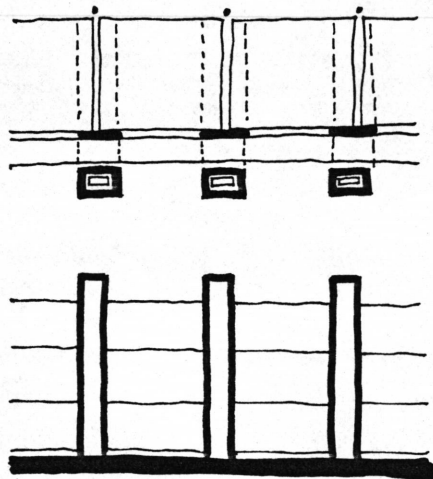
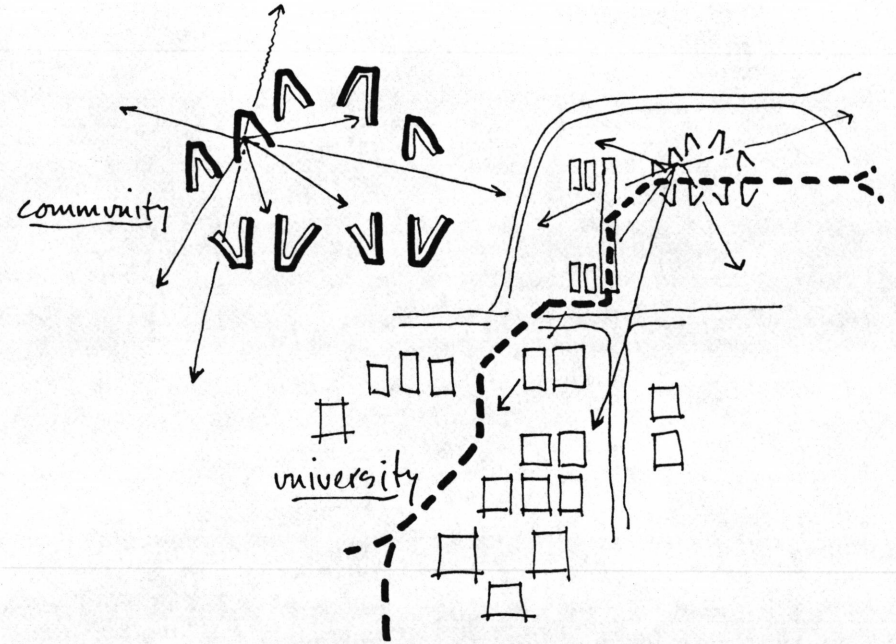
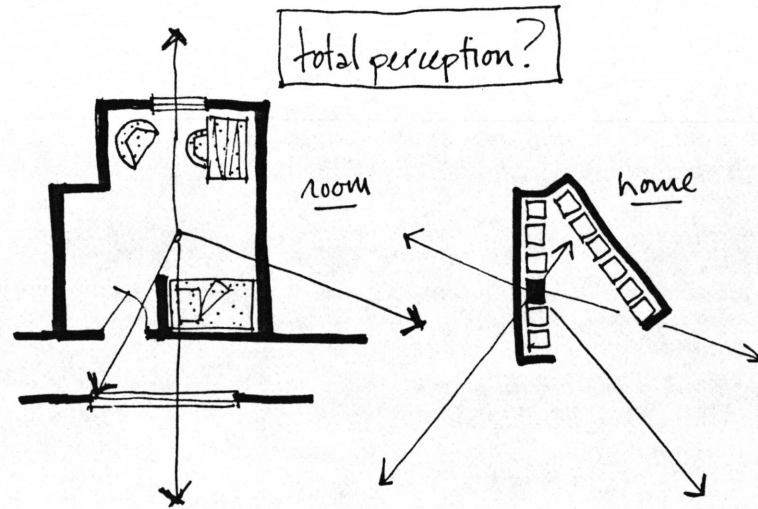

pairs of steel structures form the rails which create movement and connection

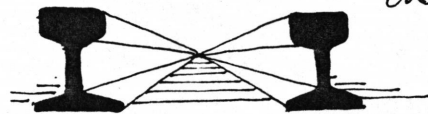

- 4 distinct functions form the building...
1. circulation (hard edge)
  2. place (soft parts)
  3. systems
  4. structure

hard edges → the system  
 soft parts → the individual

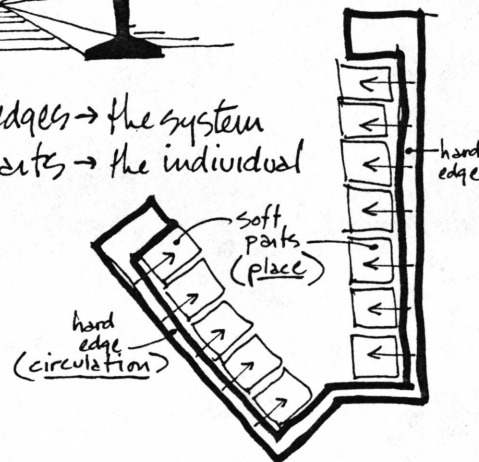

#### HOUSING DESIGN GOALS

#### STUDENTS

-allow individuality of residents to be an achievable and encouraged goal, while also responding to their needs to be part of a community.

-provide access to and perception of all layers of the university community; room, floor, wing, building, groups of buildings, pedestrian corridors, entire university and community.

-create places and environments which accommodate the transitions from student to community to individual.

#### UNIVERSITY

- economics of the housing development
  - initial cost
  - operational costs
  - flexibility in development (build in phases as units are needed)
- durability, flexibility over time.
- housing and community as a marketing tool.

#### ARCHITECTURAL

- responses to students, university, community (function, scale).
- response to site, (habitat, topo, nature and history).
- relationship to university structure and flow.
- relationship to unrelated surroundings; active railroad, viaduct, Norwood Street, sewage treatment facility, New River.
- attention to orientation; point of departure, destination or simply passing thru.

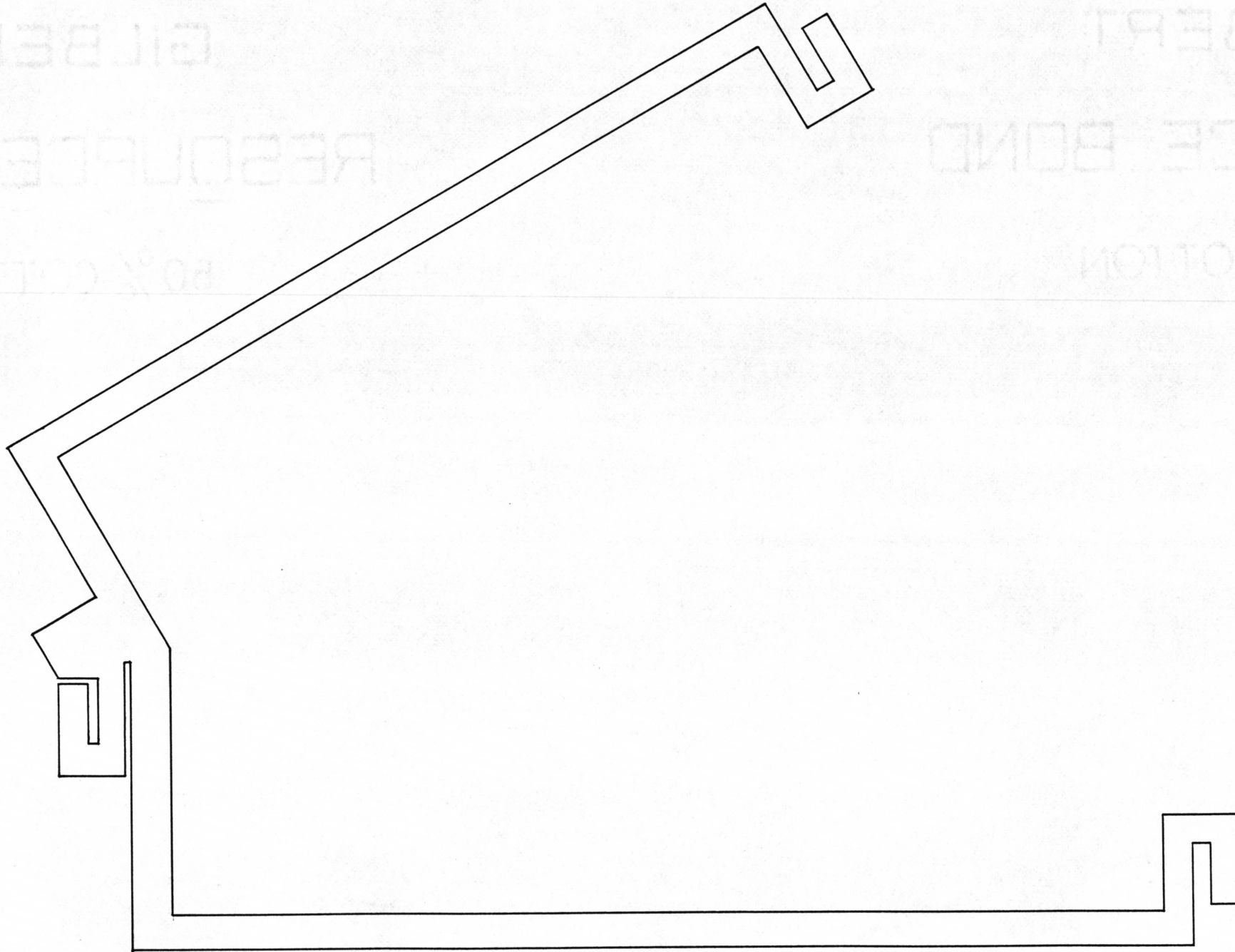

0 10

CIRCULATION

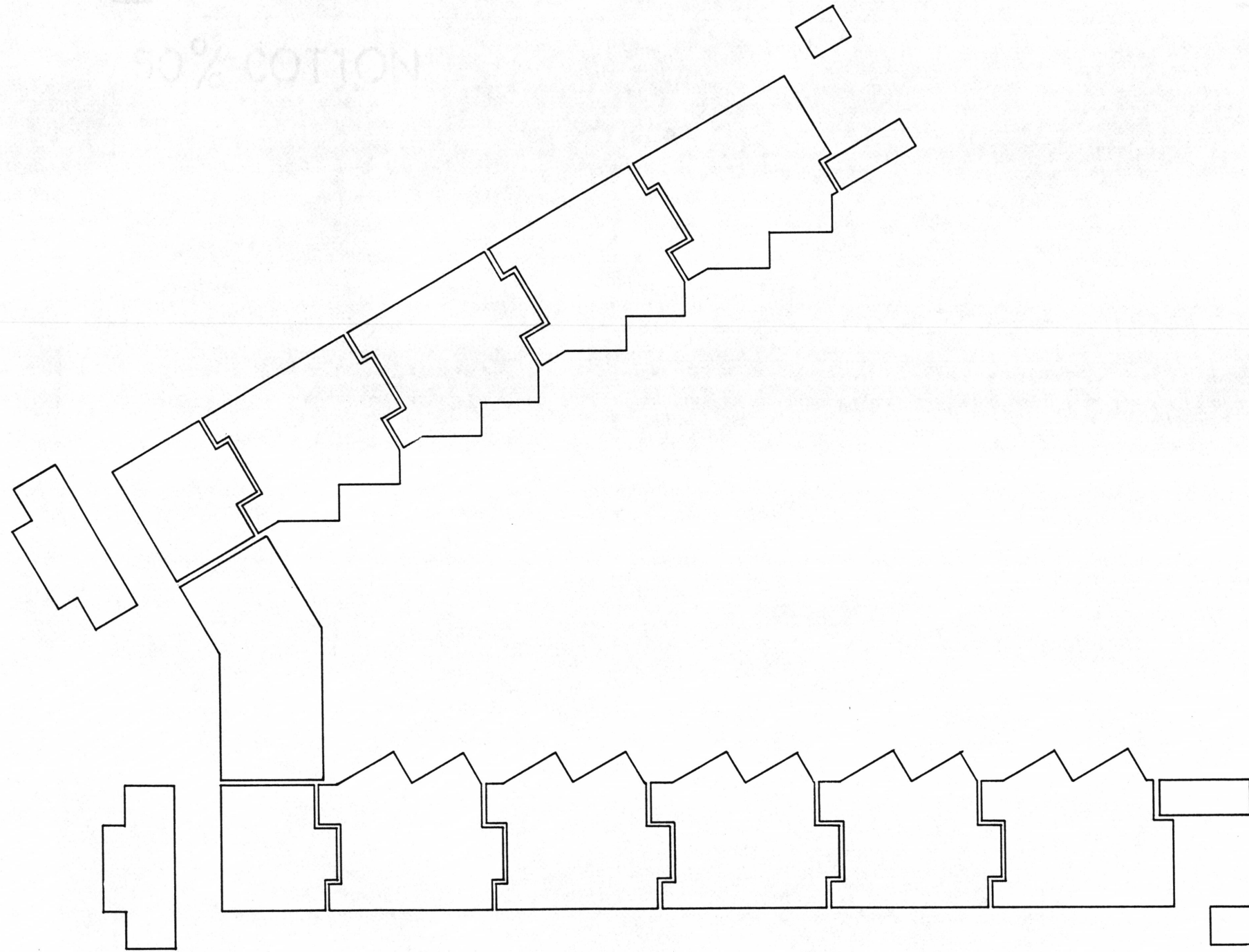

0 10

PLACE

GILBERT

GILBERT

RESOURCE BOND

RESOURCE BOND

50% COTTON

50% COTTON

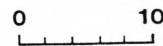
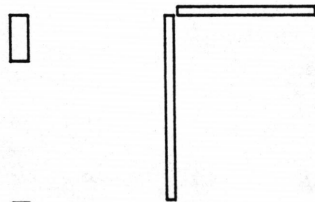
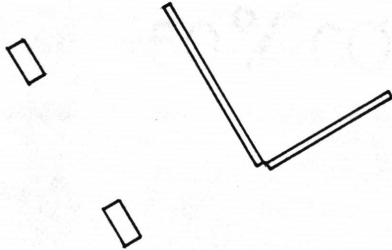

SYSTEMS



0 10

STRUCTURE

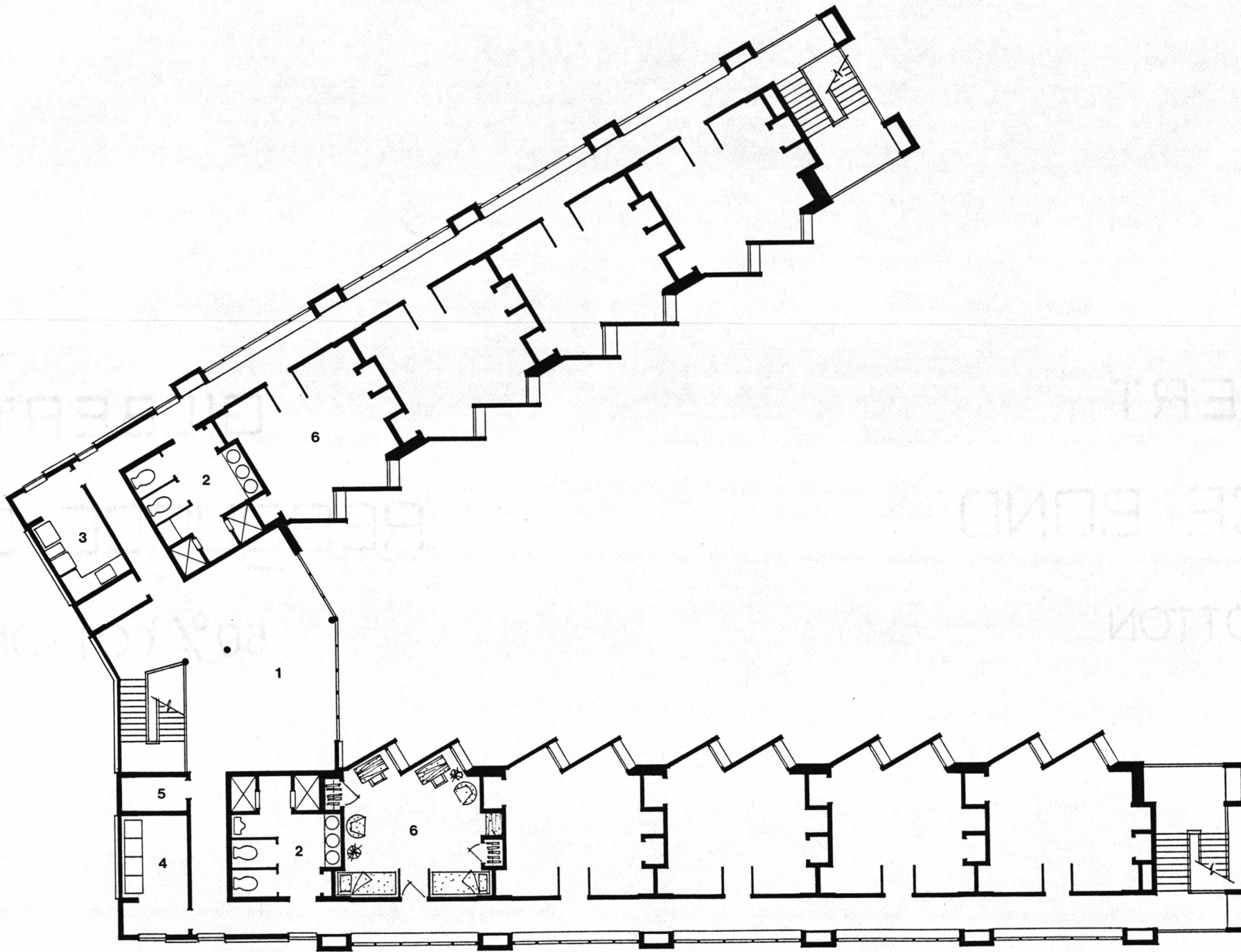

FLOOR PLAN

- 1. Commons
- 2. Toilets & Showers
- 3. Kitchen
- 4. Laundry
- 5. Storage
- 6. Typical Room - 2 Persons

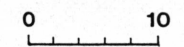

FLOOR PLAN - Typical of three floors  
in each building

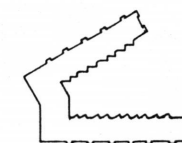
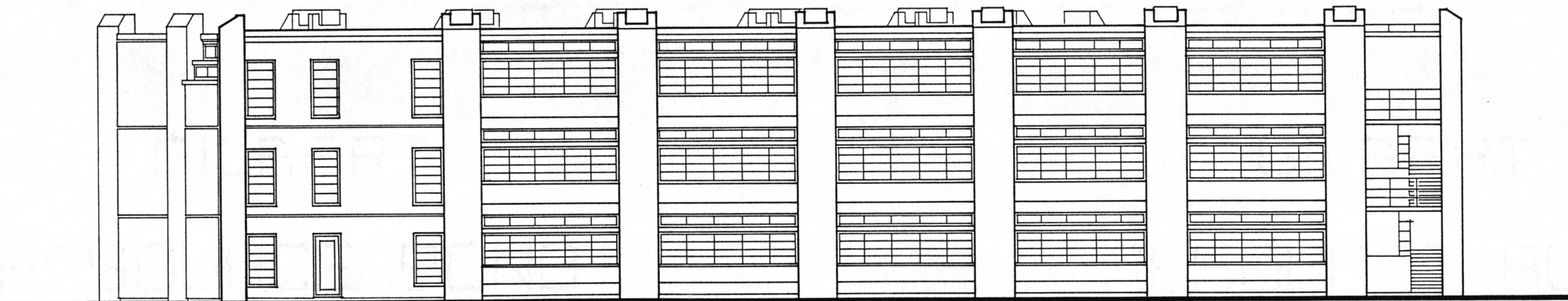
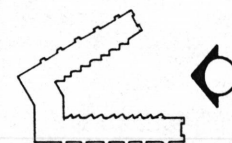
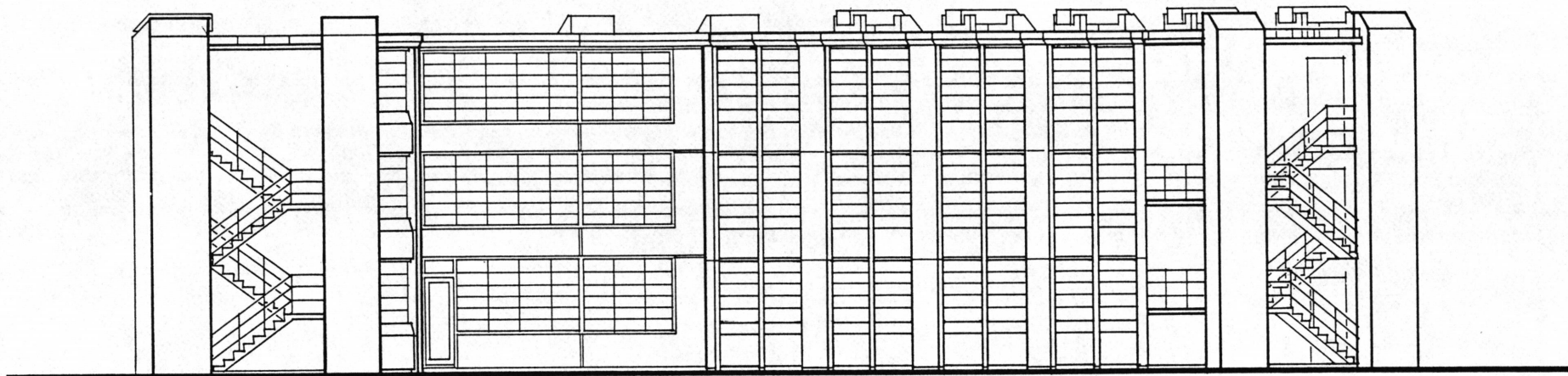

0 8



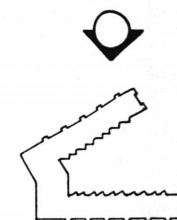
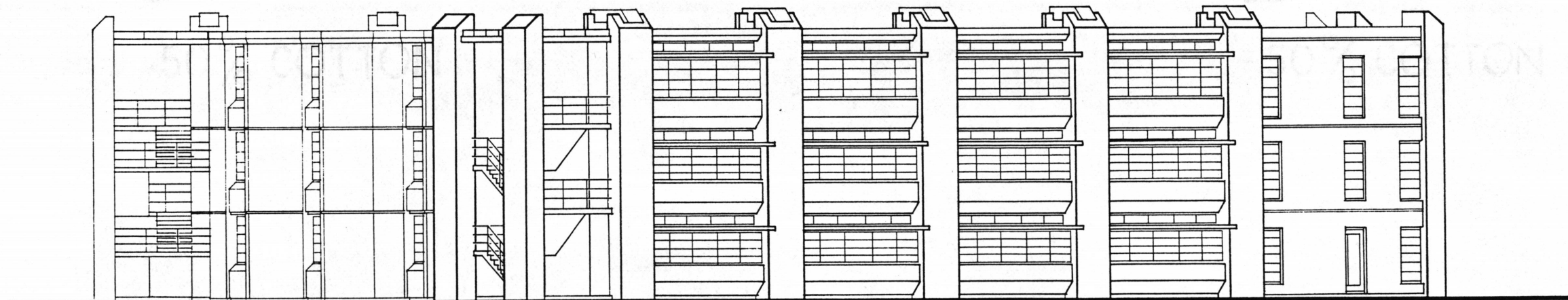
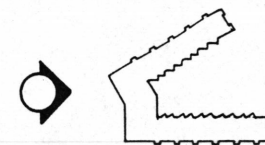
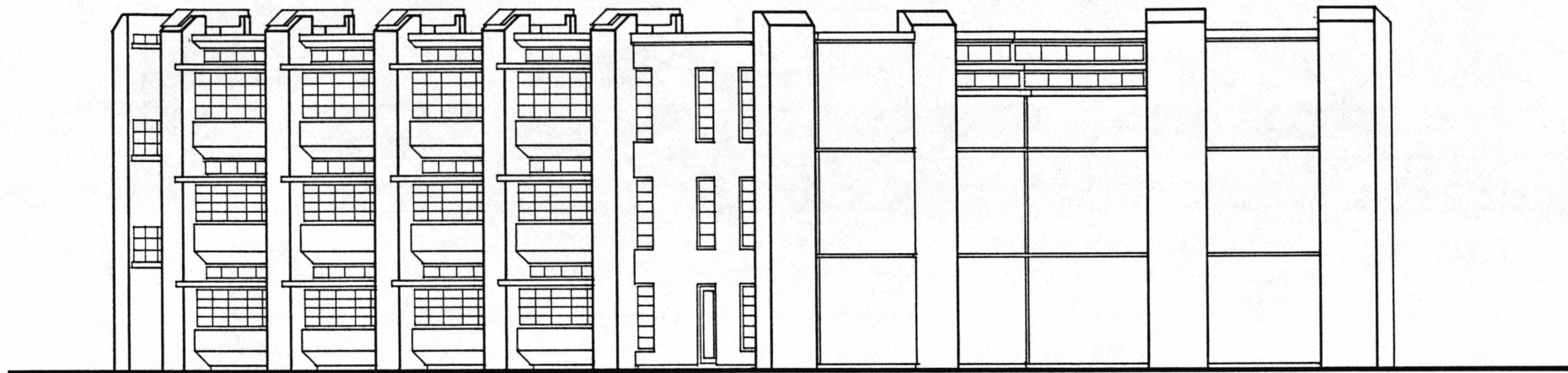

0 8

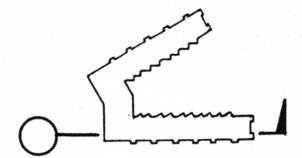
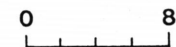
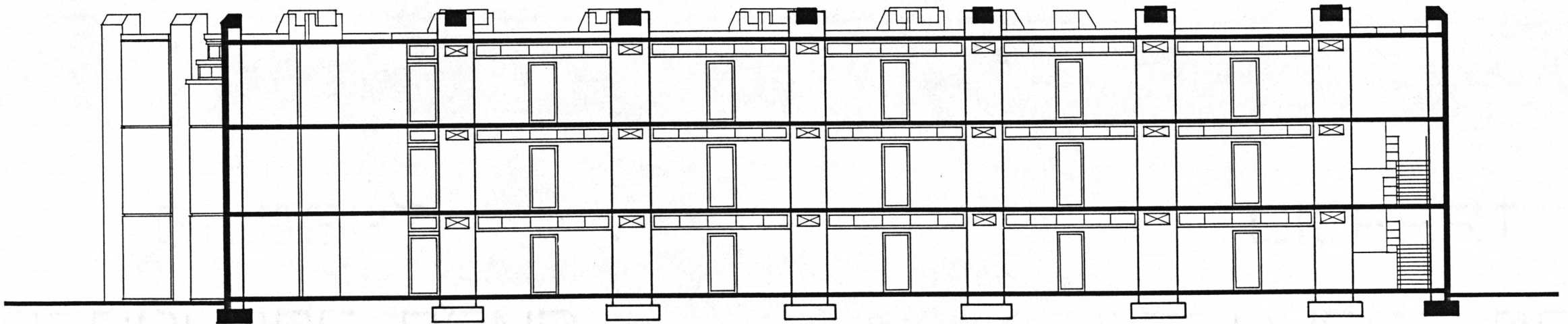
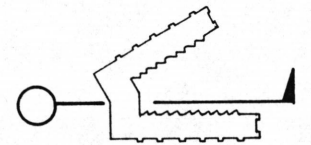
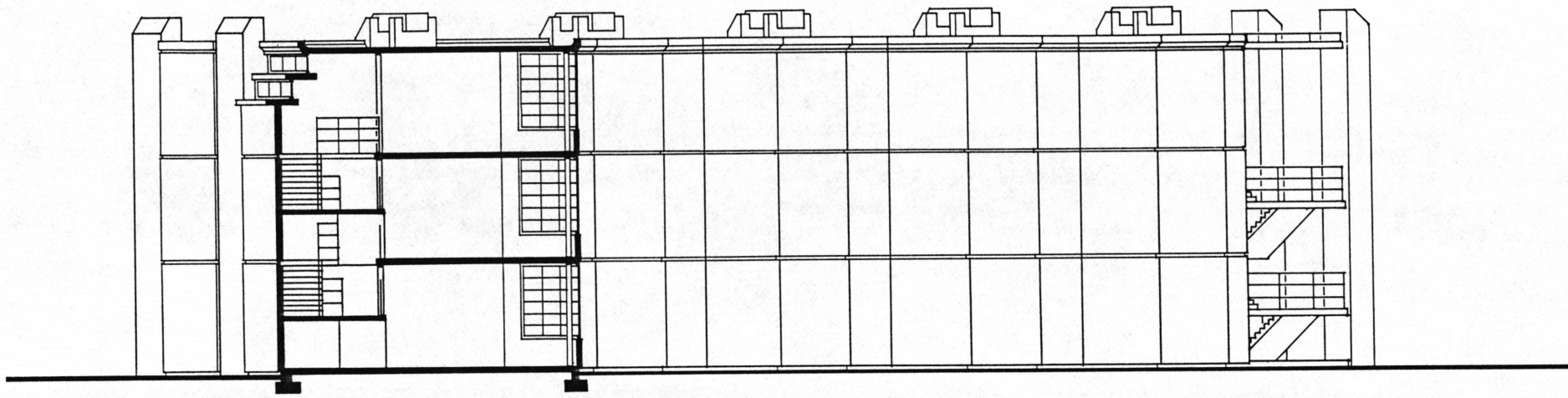

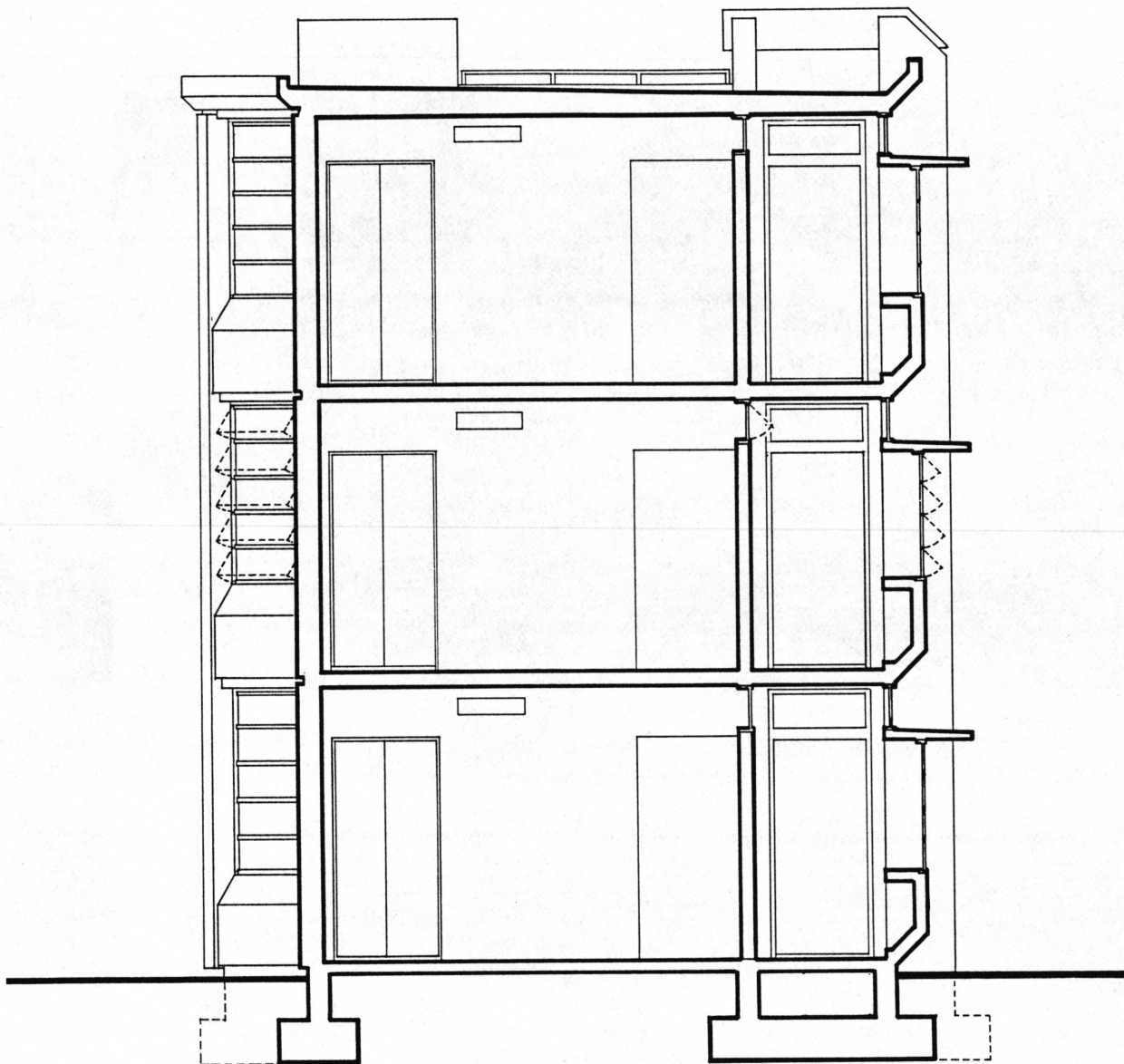

#### ENERGY CONSERVATION

The reason for incorporating passive, energy efficient design into buildings is to save on operational costs which might otherwise be incurred in order to heat, cool and ventilate. Several key determinations were made to establish architectural energy goals:

- An efficiently shaded and ventilated building located in the Virginia highlands will require no additional cooling.
- University housing requirements during summer sessions are greatly reduced, further diminishing the importance of cooling in most campus dormitories.
- University heat is cheap heat. A large central plant utilizes coal to create steam and hot water which is then piped underground and used to heat all university buildings.

Climate, building use and present university energy systems make it impractical to consider elaborate architectural energy controls a cost efficient initial expenditure. Energy design goals will instead emphasize quality co-existence of the building, the environment and the occupants through subtle manipulations of other primary design commitments.

Daylighting, natural ventilation and solar exposure considerations are made with these commitments in mind.

0 4

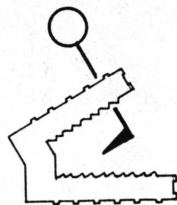

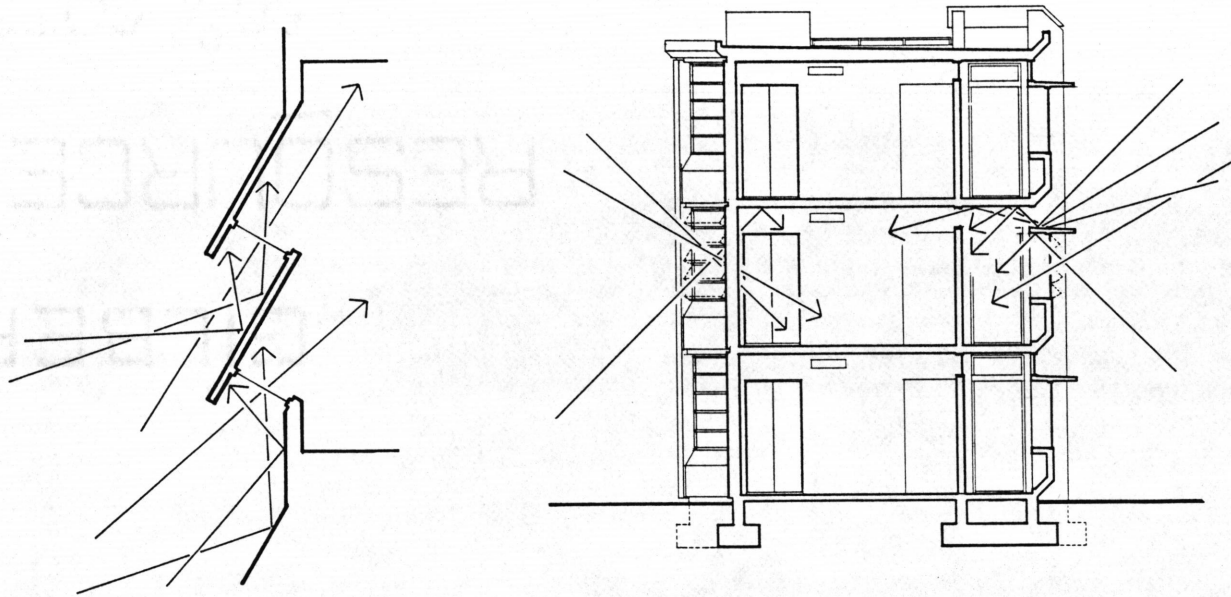

#### DAYLIGHTING

The strategy is to supply evenly distributed daylight to all portions of the hall and rooms without sharp, distracting contrast. A light shelf is utilized on the hallway side to limit the amount of direct light coming in through the large windows. Skylite is reflected off the top of the shelf and spread across the hall ceiling. High windows which reach to the ceiling in the wall separating the rooms from the hallway will allow a limited amount of this reflected light to enter that part of the room. Ground reflected light is also dispersed off the bottom of the light shelf into the hallway. Sharp contrasts from shade to light should be minimal. The amount and quality of light entering the rooms is controlled by the configuration of the precast panels into which the windows set and by hand operated blinds.

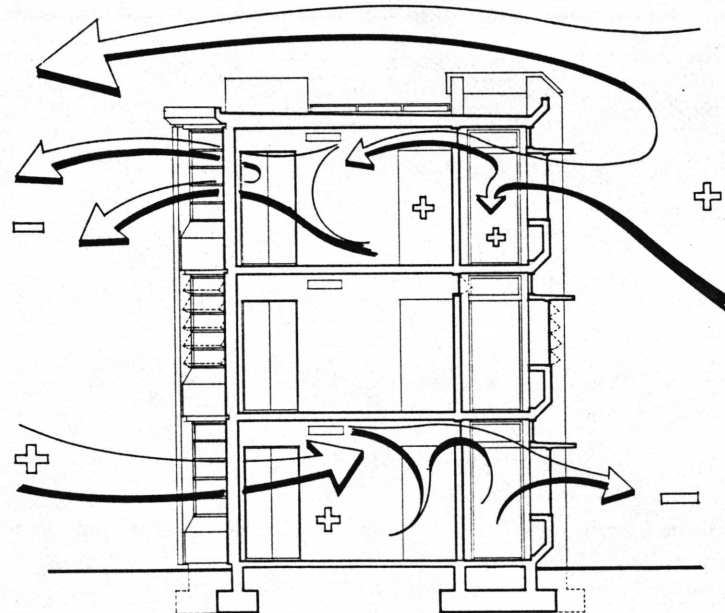

#### NATURAL VENTILATION

The single load, winged configuration of the buildings with large, operable windows will allow air to flow through the wings. The number of adjustments the airflow has to make is minimized as it moves from the high pressure created on the windward side to the low pressure on the leeward side. The awning type windows are hand controlled and those located in the hall will be the responsibility of the individuals occupying the room at that segment of the wing. Awning windows will allow 100% ventilation area while providing some protection against rain in the event they are left open.

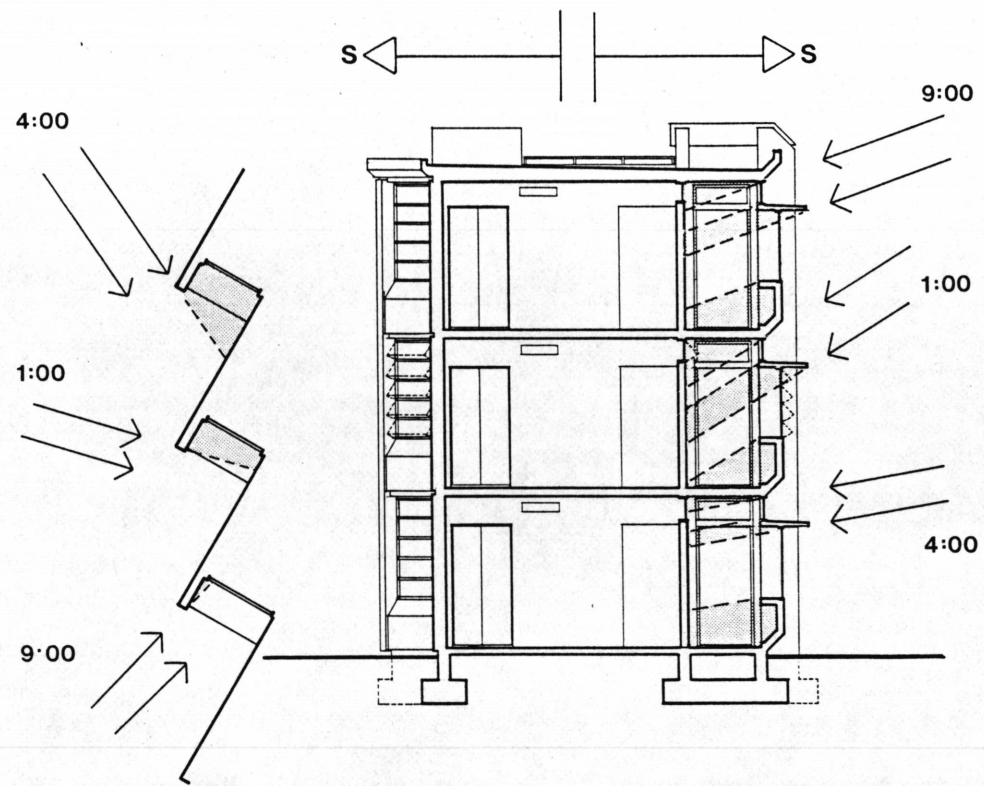

JAN 21

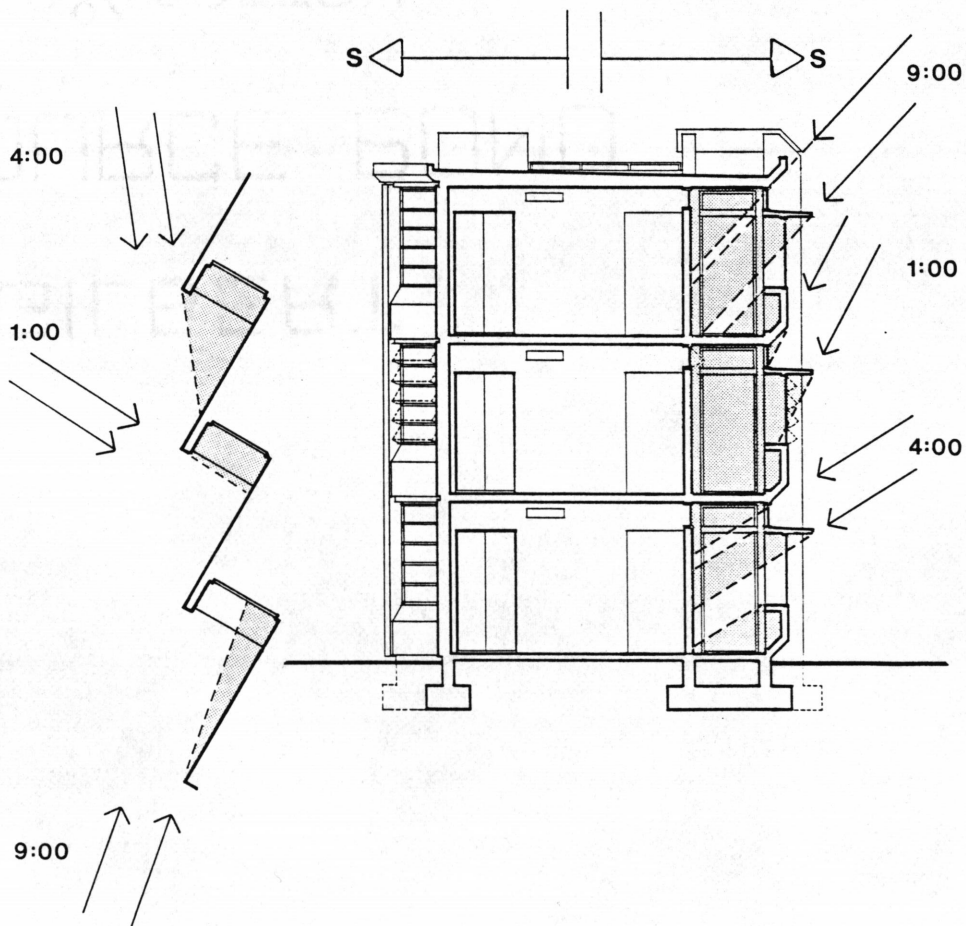

AUG 21

SOLAR EXPOSURE

Solar considerations involve the use and manipulation of the precast panels which make up the skin of the building. In orientations where solar exposure can be controlled the hallway light shelf will be sized to allow winter time sun to warm the hall while providing a shading device against the sun at warmer times of the year. The room windows can vary somewhat in the depth they are recessed to either allow or prohibit solar exposure but primary solar control will be through hand operated windows and blinds.

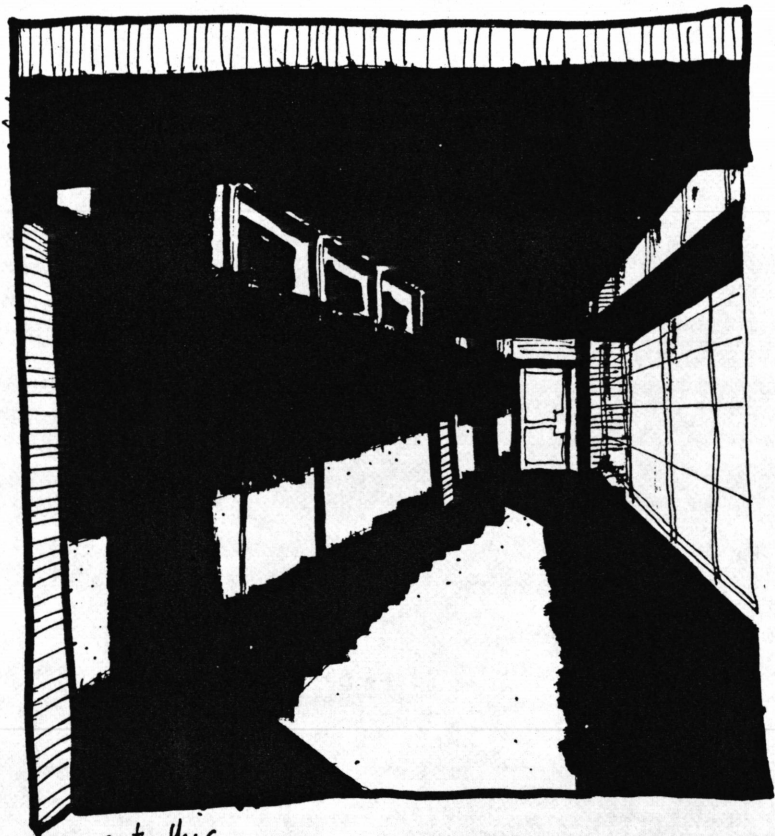

not this...



light from the corridor into the rooms, heat from chimneys to rooms thru drops in hall and over bed

the walls supply softer light than the windows - easier transition visually from dark to light.

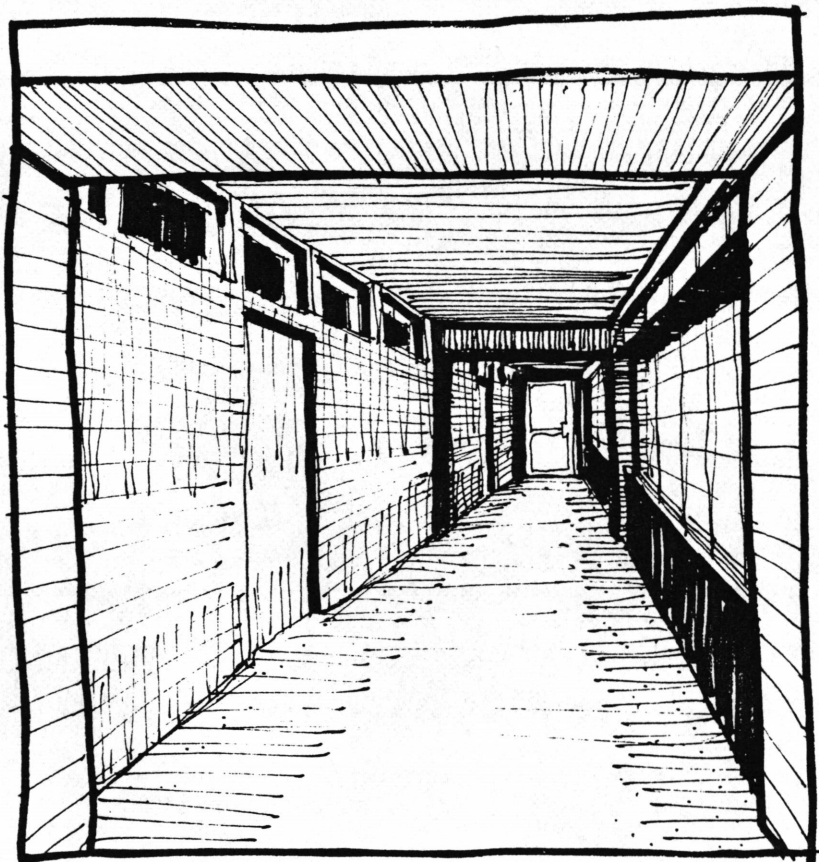

this.

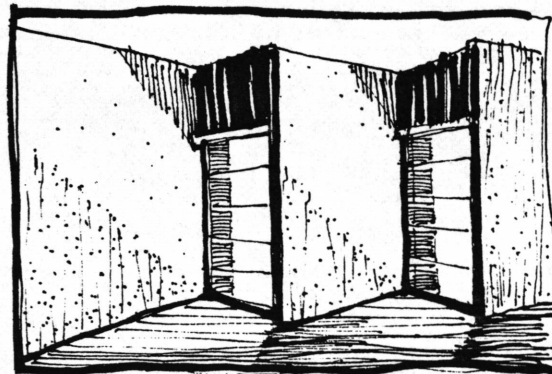

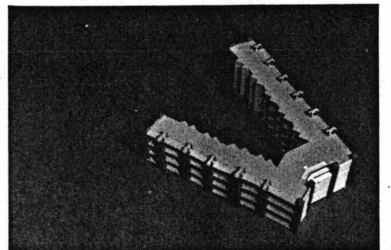
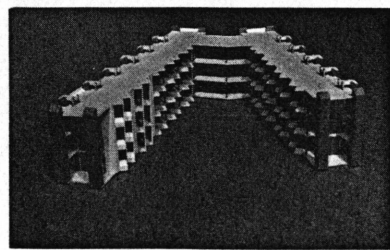
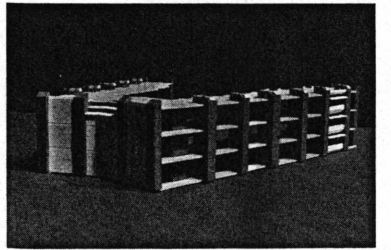
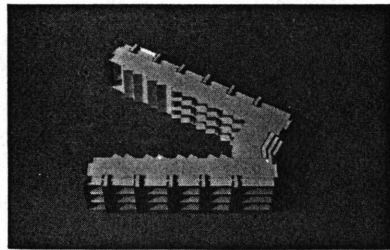
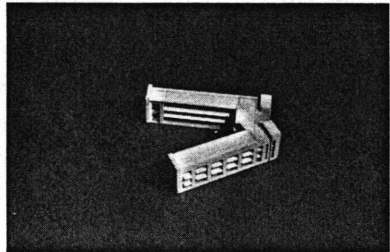
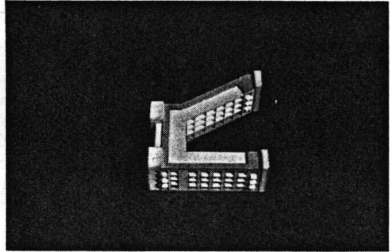
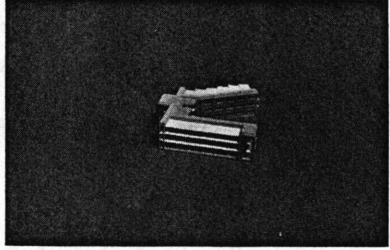
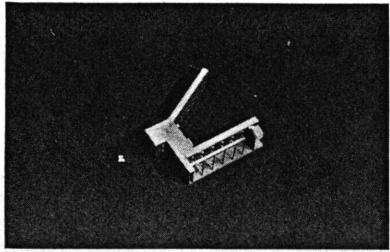
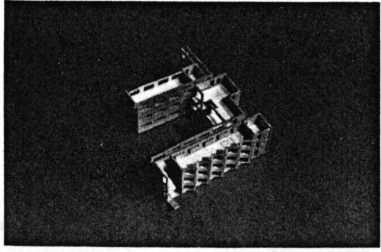

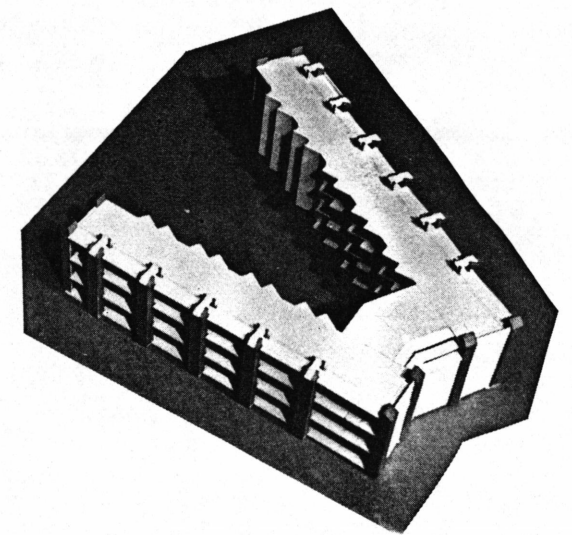
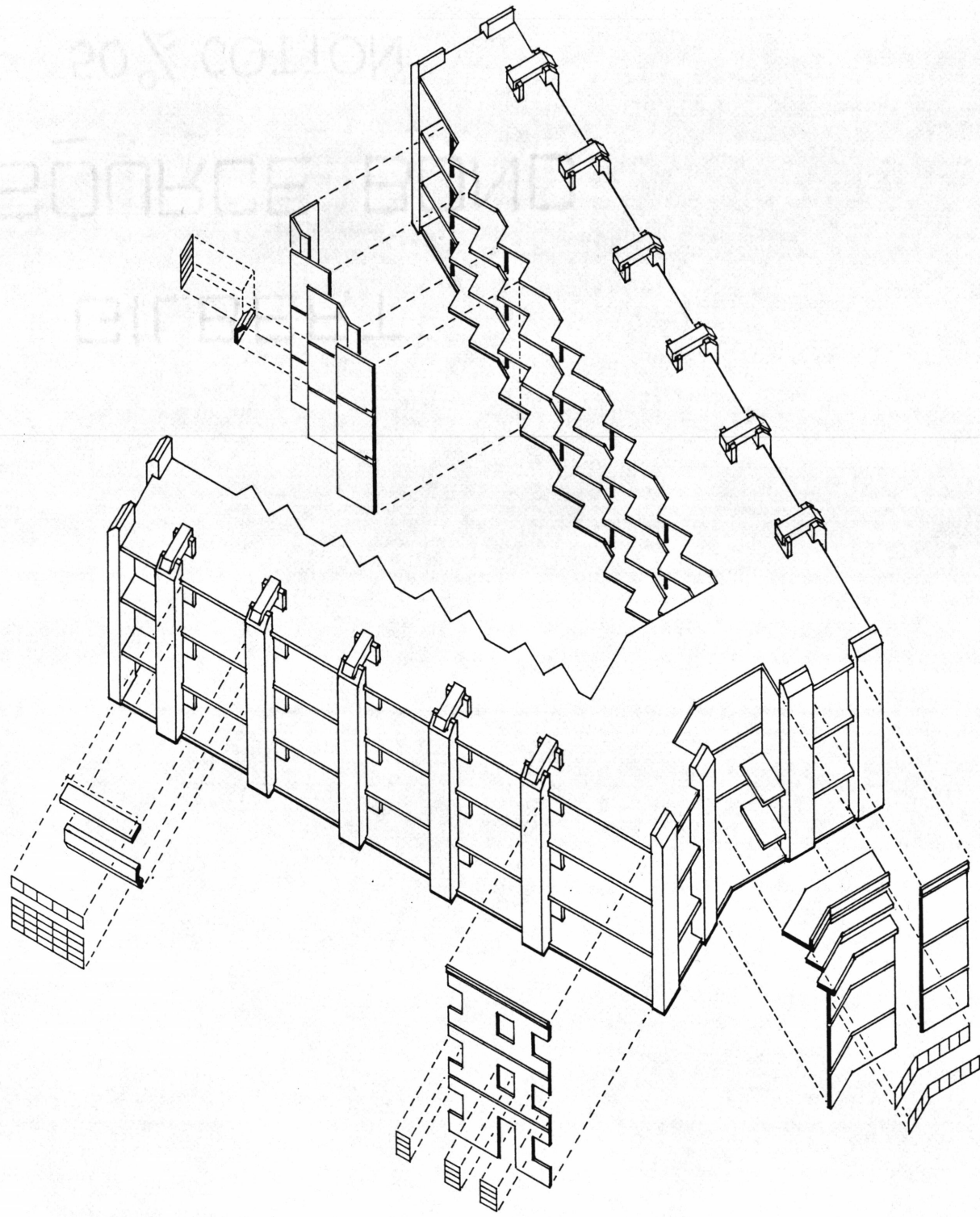



#### BIBLIOGRAPHY

Mullins, William, and Allen, Phyllis, STUDENT HOUSING - ARCHITECTURAL AND SOCIAL ASPECTS, 1971.

STUDENT HOUSING, a report from the Educational Services Laboratory, 1972.

Fengler, Max, STUDENT DORMS AND HOMES FOR THE AGED, 1964.

Sternberg, Eugene and Barbara, COMMUNITY CENTERS AND STUDENT UNIONS, 1971.

Mikillides, Byron, ARCHITECTURE FOR PEOPLE, 1980.

Brambilla, Robert, and Longo, Gianni, FOR PEDESTRIANS ONLY, 1977.

Evans, Benjamin, DAYLIGHT IN ARCHITECTURE, 1981.

DESIGN AND ENERGY, a competition sponsored by the United States Department of Energy, AIA, Royal Architectural Institute of Canada, and the Canadian Department of Energy, Mines, and Resources, Ellen Palmer, Ed. 1981.