



Large Round Bale Safety

*Authored by Robert “Bobby” Grisso, Extension Engineer, Biological Systems Engineering, Virginia Tech
John Fike, Forage Specialist, School of Plant and Environmental Sciences, Virginia Tech*

This Extension publication covers the safety aspects of equipment used in large round bale packages such as: balers, front-end loaders, bale handling and transport devices. The key to safe and efficient systems for handling large round bales is an operator who knows the hazards involved and who follows safety practices that can prevent accidents. Operators must be constantly alert for situations that may cause injuries to themselves or others. Besides pain and suffering, accidents contribute to higher costs in terms of unnecessary downtime or costly machine repairs. Alertness and safety consciousness can result in more efficient and profitable baling and handling.

Baler Machinery Safety

Developing safety awareness begins with the operator’s manual. Take time to read the manual and become reacquainted with the machine at the beginning of each season. Insist that all operators be trained and knowledgeable of all the safety precautions in the manual. Safety training and instruction are particularly important for youth and should be reinforced periodically.

Making and handling large round bales creates unique safety issues for farmers and ranchers. Large round balers have many moving parts that can cause injury or death if a person becomes entangled. Never leave the tractor seat until the PTO (power take-off) has been disengaged and all moving parts have stopped. Balers and bale handling equipment should carry warning signs or labels (Figure 1). Read and heed all safety warnings (see Table 1 for additional safety tips).

When handling large round bales, assure that the size of the tractor and has been matched to the size of the baler. Loaded balers can push undersized tractors down a hill. With insufficient traction on grassy slopes, the tractor’s



Figure 1. Typical safety sign for front-end loaders.

brakes may lock, causing the wheels to slide and the operator to lose control.

Many fatal accidents have occurred when a by-stander has become entangled in a baler during its operation. For your protection and the protection of others, keep the original shields in place on all power shafts and other moving parts such as chains, sprockets, etc.

The following mechanisms require special attention: 1) Gathering tines and bale chamber belts - they cannot be shielded and must be avoided while the unit is in operation. 2) Baler gate - it can close on a bystander (Figure 2). As an operator, make sure that everyone a safe distance away before engaging the equipment.

Heat can build up due to friction created by worn or faulty bearings and baler belts. Farmers report that this friction and overheating has caused bales to ignite when these parts come in contact with forage material - especially dry hay. People have been burned trying to deal with a baler fire. Always carry a 10 pound (ABC) dry chemical fire extinguisher on the tractor. Many balers also come with attached water fire extinguishers.

Table 1. Round Baler Safety Tips.

- A round baler is bulky and reduces operator vision to the rear. Be watchful when backing the baler.
- Assure no one is near the rear gate when it is being raised and lowered.
- Keep everyone clear of the rear of the baler during unloading.
- Large round bales can roll after discharge when on hilly terrain.
- Before servicing, cleaning, or adjusting a round baler, disengage the tractor PTO and shut off the engine. Never attempt to pull hay or twine from an operating baler.
- Block the gate before working under it. Use the safety lock system for the baler gate or the safety stops for the gate lift cylinders.
- Keep the PTO properly shielded.
- Before working on or under the baler, shift the tractor transmission into park and lock the brakes, or block the baler wheels if the baler is not hitched to a tractor.
- During operation, remain seated on the tractor seat to reduce the chance of falling into the path of the baler.
- Never allow passengers to ride on the baler during operation or transport.
- Be extremely cautious when operating a baler on uneven or hilly terrain. Round balers are top heavy (high center of gravity) and could tip sideways if one wheel drops in a hole, ditch or other irregularity, especially if carrying a near-completed bale.
- Raise the pickup to clear humps and obstacles when passing over uneven terrain.
- Avoid sharp turns; with the tractor wheels set wide to straddle windrows, rear tires could strike the baler tongue on sharp turns.
- Never be in a hurry about anything connected with the baling operation.
- Keep safety signs clean, readable and free from obstructing material. Replace damaged or missing safety emblems with new ones. Instruct all operators on the meaning of the hazard signs.

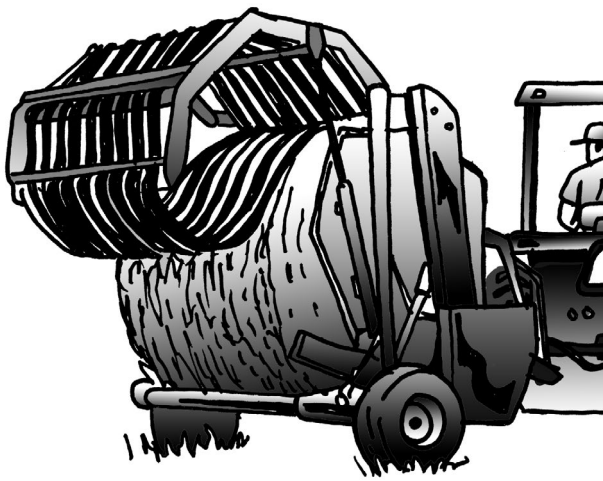

Figure 2. Be sure no one is near the rear gate when it is being raised or lowered.

Bale Handling on Hillsides

Operating large round balers on a slope is a greater concern than almost any other machinery operation. Bales on a slope have the potential to roll down the hill, break through fences and cross highways, leading to bodily harm and potential property damage. Always orient the bale correctly before ejecting the bale from the bale chamber. Sometimes this just means backing the baler at the correct angle to eject the bale perpendicular to the slope. The objective is to make certain that the bale will come to rest securely on the hillside.

This also will reduce risk and facilitate bale handling (described below). Steep slopes may require that the bale be hauled to a flat location before ejection.

Handling Large Round Bales

Whereas small square bales, weighing 35 to 85 pounds, are traditionally handled and stacked manually or with a bale loader, large round bales usually weigh between 500 and 2,500 pounds and must be handled mechanically. Because of their weight, these bales can cause significant injury if they roll into or fall on an individual.

Front-End Loaders

Many people use front-end loaders to move and stack large round bales. Use caution when hauling large round bales or any heavy load on a front-end loader. Improper handling can cause side overturns or lead to a bale rolling down upon the tractor, crushing the operator. It is extremely important that the size of the tractor and loader are matched properly to the size and weight of the bales being handled.

Side overturns result from the change in the tractor's center of gravity due to the additional weight of the bale. Figure 3 shows what happens to the center of gravity.

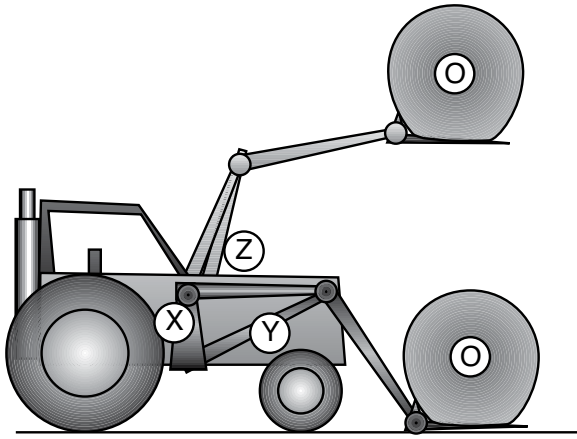

Figure 3. The point marked “X” is the normal center of gravity with a front-end loader. As a large bale is added, the center of gravity moves to a point marked “Y”. When the load is raised, the shift in center of gravity increases the chance of overturning. The point marked “O” is the center (to point “Z”) of gravity for the round bale.

The normal center of gravity with a front-end loader is at the point marked “X.” When a large round bale is carried on the front-end loader close to the ground, the center of gravity moves forward, represented by point “Y.” The point marked “O,” or half the diameter or length of the bale, is the bale’s center of gravity.

Table 2. Front-End Loader Safety Tips.

- Never walk or work under a raised loader.
- Raise and lower loader arms slowly and steadily.
- Allow for the extra length of the loader when making turns.
- Be careful when handling loose or shiftable loads.
- Never move or swing a load as long as people are in the work area.
- Stay away from the outer edge when working along high banks and slopes.
- Watch for overhead wires and obstacles when you raise the loader.
- Carry the load low to the ground and watch for obstructions on the ground.
- Always use the recommended amount of counterweight to ensure good stability. Add recommended wheel ballast or rear weight.
- Operate the loader from the operator’s seat only.
- Move the wheels to the widest recommended settings to increase stability.
- Do not lift or carry anyone on the loader, bucket or attachments.
- Lower the loader when parking or servicing.
- Assure all parked loaders are on a firm, level surface and all safety devices are engaged.
- Visually check for hydraulic leaks and broken, missing or malfunctioning parts, then make necessary repairs. Wear personal protective equipment (PPE).
- Under pressure, escaping hydraulic oil can have sufficient force to penetrate the skin, causing serious personal injury. Injuries resulting from oil penetrating the skin are very difficult to treat. Use a piece of cardboard or paper to check for pinhole leaks.
- Before disconnecting hydraulic lines, relieve all hydraulic pressure.
- Be certain anyone operating the loader is aware of safe operating practices (hand signals) and potential hazards.
- Extending the tines (forks) of a loader may look like a good way to solve the loading problem, but when this is done the tractor’s center of gravity is moved forward. Extra stress is placed on the loader, the hydraulic system and tractor front end.
- All tractors used to move bales should have roll-over protective structures (ROPS). ROPS can either be a protective enclosed cab or a roll bar with a canopy.
- Tractor operators should utilize the tractor seat belt at all times when operating the tractor, regardless of the

Some operators will carry the load high for improved visibility while driving. However, when the loader is raised as shown, the tractor’s center of gravity moves to the point marked “Z,” which is both forward and higher than the original center of gravity, “X.” In the raised position, the tractor is less stable and the potential for side overturn increases.

Now visualize this tractor on a slope transversing with the contour with two wheels on the downhill side and two wheels on uphill side. As the bale is lifted, the center of gravity gets higher and the potential for the tractor to overturn and roll down the hill increases.

The chance of side overturns increases when carrying a load on the front-end loader, especially on slightly uneven ground. Moving the center of gravity forward causes a transfer of weight from the rear wheels to the front, making it much easier to bounce a rear tire off the ground when passing over bumps or holes. Plus, the additional weight on the front tires may exceed the axle and tire load-carrying capacity.

Loss of traction also occurs when the center of gravity is moved forward. Weight is transferred forward from the rear tires during bale handling, and the loss of traction can be a problem when moving bales up a slope or on wet soil. Loss of traction can result in a braking loss on all surfaces. Mounted front-end loaders (see Table 2 for additional safety tips) should be used when the load is properly counter-balanced by adding weight to the rear of the tractor. This additional weight will bring the center of gravity back to the original center.

Another dangerous situation occurs when the loader is raised too high. The bale can roll down the loader arms onto the operator. If you handle a bale with the front-end loader, use proper bale handling devices to keep the bales on the loader, keep the load as low as possible and move slowly. Loader attachments such as spears and grapple-forks minimize the risk of the bales rolling down the loader lift-arms.

Bale Handling Devices

A number of large bale handling devices are on the market. Three-point hitch spears that are pushed through the bale and arms that grasp the bales are available. It is better to handle bales with rear attachments than with the front-end loader. Rear tires are better suited to carry the extra weight, and there is less chance of side overturns because the bale is not lifted as high. Know where the center of gravity is when using this handling equipment, especially if the load extends far to the rear of the tractor. This can overload the tractor hydraulic system.

Rear bale spears are not without risks. Avoid lifting bales with a 3-point lift on the rear to a height where the front tractor wheels are barely in contact with the ground. This causes steering and stability problems. At least 30 percent of the front weight of the tractor should remain on the front wheels.

Adding weight to the rear of the tractor increases the possibility of the front of the tractor flipping up and over the back wheel (a rear overturn). However, the bale and carrying attachment may prevent this occurring. Some operators use both a rear-mounted handler and front-end loaders (Figure 4). This will reduce the stability problems, but the bale loads must not exceed the tire-carrying capacity of either the front or rear tires.

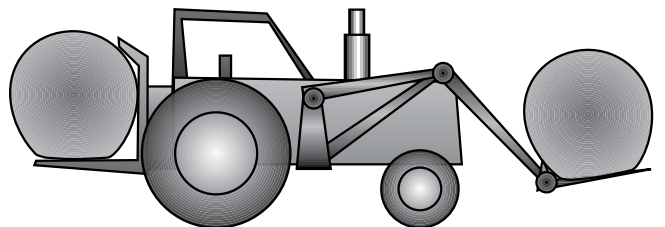

Figure 4. Rear and front-end bale-handling devices.

As much as possible, operate bale handling devices on level ground. When picking up a bale with a front-end loader, drive up the slope in order to spear the bale. Ejecting the bale with the face oriented up and down hill will facilitate this approach. Care must be exercised when driving across the slope to pick up a bale.

When using a front-end loader to load round bales on a trailer, drive the trailer across the slope and load from the uphill or downhill side. Never try to place a second-layer of bales on a trailer up or down the slope. To accomplish this, the tractor must travel across the slope, increasing the potential for overturn.

Transport

Special low clearance trailers that carry 4 to 10 bales which can be loaded directly from the ground and are preferred for moving bales. They reduce or eliminate problems of overloading the hydraulic system and reduce potential overturn. They also handle more than one or two bales at a time.

During transport, excessive weight on the trailer can make stopping difficult. At 1,500 pounds per bale, a 4- to 10-bale loads weigh between 3 to 7 tons. Add the weight of the bale trailer to this and the total transport weight approaches 9 tons. The tractor must be the proper size and weight to safely stop all of the bale and trailer weight.

Since these trailers can carry 4 to 10 bales, there can be a problem with stopping the load. At 1,500 pounds per bale, load size is between 3 to 7 tons. Add the weight of the bale trailer to this and the total transport weight approaches 9 tons. The tractor must be the proper size and weight to safely stop all of the bale and trailer weight.

Use a lower gear when going downhill, since the tractor brakes alone may not be able to stop the load. When going uphill, also use a low gear, so that you will

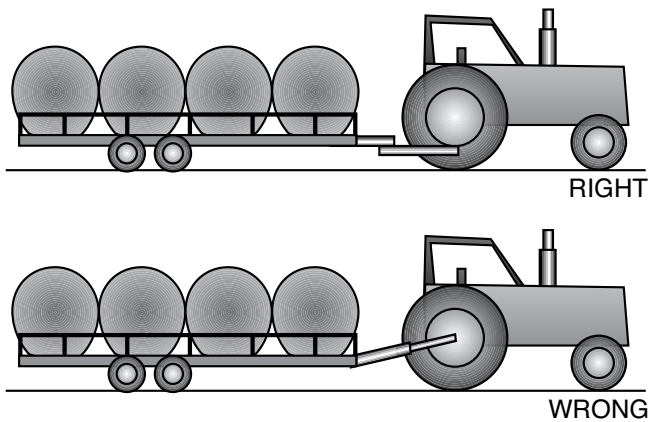

Figure 5. Hitch only to the tractor drawbar. Hitching anywhere else increases the chances of tractor overturn.

not have to hold the load with the tractor brakes while changing gears up the slope. Do not attempt to change gears during descent; begin descent in a low gear.

Install brakes on any transport trailers carrying heavy loads. Never operate a hay trailer on the highway if it is not equipped with brakes. This accessory makes stopping easier and safer. Trailers can be equipped with electric, hydraulic, or surge brakes. Most models can be equipped with a breakaway device that will lock the brakes if the trailer breaks loose from the towing vehicle.

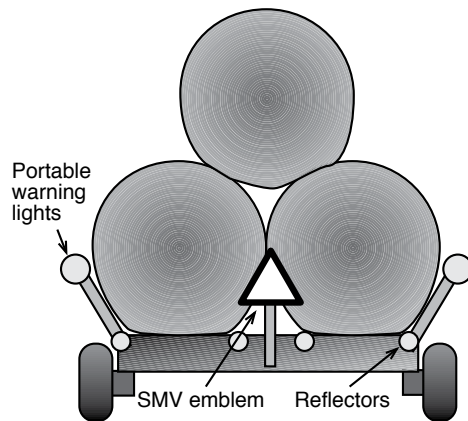

Figure 6. The trailer equipped with SMV, reflectors and warning lights.

Keep people out of the area between the trailer and tractor during hitching. Hand signals should be used and understood by both the operator and those assisting (see Table 3 for safety tips). Hitch the trailer only to the drawbar; never attach to any other point on the tractor (Figure 5). Assure the tractor drawbar is in the lowest, most centered and stationary position.

This will keep the tractor's front wheels moving straight and provide extra steering control. Use a safety locking hitch-pin and secure the trailer with chains.

Table 3. Tractor Operations Safety Tips.

- Most baler injuries and fatalities occur from bales rolling out of the loading forks or bucket onto the operator.
- Know the tractor, the implements and how they work. Be thoroughly familiar with both the operator's manual and the tractor before starting.
- Know the controls, where they're located and how they work. Practice stopping the tractor and PTO quickly in the event of an emergency.
- Use roll-over protective structure (ROPS) and seat belts. Most tractor fatalities are caused by overturns.
- Be familiar with the terrain and drive safely. Use caution on slopes, slow down for all turns.
- While on the highway, use appropriate lighting and follow all rules of the road.
- Never operate an engine in a closed shed or garage. Carbon monoxide is colorless, odorless, and deadly.
- Keep the PTO properly shielded.
- Keep hitches low and always tow or pull from the drawbar. The tractor is designed so that it will not overturn backwards if the load is hitched properly to the drawbar.
- Never chain the rear wheels with a piece of wood to prevent slipping. The tractor can be "torqued-over." The torque supplied by the transmission will lift the tractor (rather than turning the wheels) and flip it over backwards.
- Never jump off a moving tractor or leave it with the engine running. Never try to jump onto a runaway tractor; it is extremely dangerous.
- Never refuel while the engine is running. Never refuel an overheated engine. Do not add coolant or water to a radiator while the engine is hot; radiator coolant can erupt and scald.
- Keep children off and away from the tractor, implements and attachments at all times.
- Never be in a hurry. Take your time, take a break and do it right.
- Keep safety signs clean, readable and free from obstructing material. Replace damaged or missing safety emblems with new ones. Instruct all operators on the meaning of the hazard signs.
- Do not transport wide loads after daylight hours, in poor visibility or bad weather.

When pulling heavy loads, trailer tires should be properly inflated before transporting round bales on the highway. A slow-moving vehicle (SMV) emblem (Figure 6) should be clean and visible. Any worn or faded emblems should be replaced. Remember, farm vehicles are subject to all traffic laws. If a trailer moves large round bales, the bales should be secured with a strap that has tensile strength greater than 1.5 times the load it is holding. If the transport has large round bales stacked side by side, you probably have a wide load. These loads are illegal on interstate highways. On other roads, wide loads have to follow all traffic laws. Check with state and local police for additional requirements.

Do not allow bales to rest against the trailer tires. At transport speeds, the friction of the hay against the rotating tire can generate enough heat to ignite the hay. Remember that trailers pulled by a pickup have faster transport speeds than tractors, and heat sufficient to cause a fire can occur in a short distance (1/2 mile). Trailer fires are difficult to control and can lead to loss of hay, trailer and tractor (or pickup).

While driving on the highway with any vehicle, be sure that the driver can see and be seen. Use flashing lights and have an SMV emblem properly mounted. Allow time to pull into and across traffic. Avoid sudden, erratic, or unexpected maneuvers. Keep to the right, pull over at a safe place to let traffic pass. Never wave vehicles to pass; let drivers pass at their own discretion. Signal all turns well in advance and make sure no one is passing when turning left. Pull completely off the road if something goes wrong.

Awareness

Fatigue often is an operator's most common physical problem. Long workdays and the pressure associated with baling and forage harvesting can be stressful. Fatigue can slow reaction time, impair memory, and even cause hallucinations. Safety breaks, which include stretching, breathing deeply, and periodically walking around, can help prevent the effects of fatigue or boredom. If you feel drowsy, stop and have a cup of coffee, soda or soup. If you still feel drowsy, discontinue operations that need your full attention.

Large round baling is a good method of harvesting, storing and moving hay crops but keep safety in mind. Safety, in the final analysis, is largely a matter of common sense and patience. Most manufacturers have designed and built equipment with your safety in mind. The ultimate responsibility for its safe and proper operation lies with the operator.

Acknowledgments:

The author acknowledges the coauthors for their contributions of the previous version, John Perumpral, Don Ohanehi, Ray Smith, Bruce Stone, and John Cundiff.