

THE EFFECT OF PRESSURE ON THE PROCESS
OF ATOMIZATION

By

MILTON H. SHACKELFORD

A Thesis Submitted to the Graduate Committee
In Partial Fulfillment of the Requirements
For the Degree
of

MASTER OF SCIENCE

in

Mechanical Engineering

Approved:

Head of Department

Dean of Engineering

Chairman, Graduate Committee

Virginia Polytechnic Institute

1949

TABLE OF CONTENTS

	Page
I. INTRODUCTION	3
II. THE REVIEW OF LITERATURE	4
III. THE INVESTIGATION	11
A - The Object of the Investigation	11
B - Description of the Test Apparatus	11
1 - List of Apparatus	16
C - Method of Procedure	17
D - The Effect of Pressure on Atomization	18
E - Determining the Efficiency of Atomization	30
IV. DISCUSSION OF RESULTS	36
V. CONCLUSIONS	40
VI. RECOMMENDATIONS	41
VII. ACKNOWLEDGEMENTS	43

APPENDIX

I. Bibliography	44
-----------------------	----

LIST OF FIGURES

	Page
Figure 1. Schematic View of Test Equipment	13
Figure 2. Assembly Drawing of Nozzle Tested	15
Figure 3. Photograph of Fuel Spray	19
Figure 4. Photograph of Fuel Spray	20
Figure 5. Photograph of Fuel Spray	21
Figure 6. Photograph of Fuel Spray	22
Figure 7. Photograph of Fuel Spray	23
Figure 8. Photograph of Fuel Spray	24
Figure 9. Photograph of Fuel Spray	25
Figure 10. Photograph of Fuel Spray	26
Figure 11. Photograph of Fuel Spray	27
Figure 12. Photograph of Fuel Spray	28
Figure 13. Photograph of Fuel Spray	29

INTRODUCTION

The primary purpose of the atomization process is to break up the fuel into the smallest particles possible. The smaller the particles, and the least variation in the size of the particles, is an indication of the degree of atomization. The fuel velocity is the most important factor affecting the degree of atomization. The fuel velocity is dependent primarily upon the fuel pressure. There are other variables that affect the degree of atomization. They are, namely, (1) orifice diameter, (2) orifice diameter to length ratio, (3) the design of the fuel nozzle, (4) fuel characteristics, (5) density, pressure, and velocity of the air into which the fuel spray discharges.

The author decided to run a series of tests on a Monarch fuel atomizing nozzle to determine the effect of pressure on the degree of atomization. All other variables affecting the degree of atomization were maintained as nearly constant as possible.

II

THE REVIEW OF LITERATURE

Atomization is the process by which a liquid substance is broken up into many small particles of various sizes. This investigation is chiefly concerned with the atomization of a liquid substance which may be used as a fuel in the present day gas turbines, internal combustion engines, and steam generating boilers. There are several methods by which atomization is accomplished, but the atomization of a liquid fuel, under pressure, through an atomizing nozzle, is the method treated in this thesis.

The process of atomization has been thoroughly dealt with in regard to diesel engines in which the injection pressure generally exceeds two thousand pounds per square inch. There has been very little published data on atomization at the low pressure ranges wherein the gas turbine combustion chamber operates. In general, the pressure acting on the fuel in the nozzle of a gas turbine combustion chamber is about seventy-five pounds per square inch gage, and very seldom exceeds one hundred and fifty pounds per square inch gage. Thus, the resulting atomization of the fuel is considerably different in these lower ranges of pressure and plays a very important part in the performance of a gas turbine combustion chamber. The analysis of the process of atomization consists of two important problems, namely, (1) determining a practical means of finding the number and size of fuel droplets in a fuel spray,

(2) calculating a sound and logical means of comparing several fuel sprays in regard to their efficiency and degree of atomization.

First, all the known means of determining the number and size of fuel droplets in a fuel spray will be discussed. A very reliable method of finding the droplet size is a device created by Millikan in 1909. He was looking for a means of determining the ionic charge on a very small particle suspended in mid-air. Millikan was able to determine the size and weight of a drop of oil by observing its rate of fall. The observation was made by use of a measuring microscope, and the size of each oil droplet was calculated by the application of Stoke's Law. According to Stoke's Law, a small sphere, moving at a steady slow speed through a fluid, experiences a resisting force equal to $F=6\pi\eta av$. This force may be equated to the weight of the falling drop of oil, which is the volume multiplied by the density of the oil. Therefore, if the velocity of the falling oil droplet can be determined, the dimensions of this drop of oil can be calculated. Stoke's Law may be expressed in the following formulas: $F=6\pi\eta av$, where (F) is the resisting force, (η) is the fluid coefficient of viscosity of the medium through which the oil droplet is falling, (v) is the velocity of the falling droplet, (a) is the radius of the oil droplet. The resisting force, equated to the weight of the falling oil droplet, yields the following

formula: $\frac{4}{3}\pi r^3 \rho = 6\pi \eta a v$, where (ρ) is the density of the oil droplet and the other symbols are the same as above.

Another method of determining droplet size was employed by J. R. Joyce of the Asiatic Petroleum Company which used molten wax preheated to a temperature which gave the same physical properties as the fuel in question. This method required the collecting of the fuel spray and the sizing of all the particles by means of a sieving device. This method proved to be satisfactory, but required the handling of several millions of droplets which required a great deal of time.

The engineering experimental station of the Pennsylvania State College have investigated the behavior of fuel sprays under varying conditions and determined a feasible means of finding the droplet size. The fuel spray is collected in a tanning product, called Queol, which preserves the size and shape of the fuel droplets until a photographic picture can be taken. Thus, a certain portion of the fuel spray can be collected for a given length of time, and a photographic picture can be made of the droplets for a permanent record. This work was done in connection with diesel engines and their fuel characteristics.

The following conclusions were derived from their experimental work: (1) In all cases the greatest number of droplets is below five microns in diameter, (2) Oil injection pressure

is the primary factor determining the fineness of atomization. Increasing the oil pressure decreases the mean droplet size, (3) An influence of the air pressure was also noted. Increasing the air pressure decreases the mean droplet size, (4) Increasing the oil viscosity increases mean droplet diameter, (5) Below 0.015 inches orifice diameter the droplet sizes decrease with smaller orifice sizes. Above this orifice diameter the effect is not pronounced.

Mr. S. M. Doble, A.M.C.T., A.R.I.C., of the Research Department of Messrs. Imperial Chemical Industries, Limited, used a method by which atomized droplets of water were collected in castor oil, and photographic means were later used to obtain a permanent picture of the water droplets. In this experiment Mr. Doble was chiefly interested in finding an empirical means of designing atomizing nozzles for a given set of conditions. Thus, his chief interest was to formulate some general relations from which a nozzle could be designed to have a desired output at a given pressure, and to have a predetermined average particle size and a known apex angle of the cone of spray. In his investigation he also determined for his given design of nozzles the effects of pressure and orifice diameter of the nozzle upon the particle size.

Mr. Doble determined the following conclusions: (1) Increase of pressure from 30 pounds to 70 pounds per square inch gage decreases the average particle size only slightly

and has little effect on the spray cone apex angle. The peak volume distribution moves outward, however, towards the periphery of the cone when the pressure is increased, and a larger area is, therefore, covered more uniformly. This leads to the recommendation that the highest available pressure should be used, always with the proviso that the total output of any given nozzle is approximately proportional to the square root of the pressure, (2) Increase of the orifice diameter of the nozzle, up to the limit of 5 mm. covered by the investigation, decreases the particle size to below 100 microns (1 micron = .001 mm.) and increases the spray cone apex angle but decreases the concentration per unit area, in spite of the fact that the total nozzle output is increased. The size of the orifice should, therefore, be as great as possible, depending upon the maximum angle of spray permissible for the specific purpose of the nozzle. Also, Mr. Doble ran a thorough research showing the effect swirl vanes and plates have on the fuel spray characteristics. He concluded that they definitely affect the atomization process and can be used to vary the fineness of the fuel particles leaving the nozzle. As yet, there is considerable research work to be done on this part of the fuel atomizing nozzle.

Mr. Dana W. Lee of the National Advisory Committee for Aeronautics performed a very extensive research of the atomization and distribution characteristics of fuel sprays from

automatic injection valves in connection with compression-ignition engines. He collected the fuel droplets on smoked-glass plates in an air-tight chamber in which the conditions were similar to the combustion chamber in an internal combustion engine. It was necessary to measure and count the impressions made on the smoked-glass plate, and it was assumed these impressions were the same size as the actual fuel droplets themselves. This is not true and will yield only relative values of droplet size. Also, the larger droplets will probably have a greater spreading effect than the smaller droplets, therefore, the error in assuming the impressions are the true values will not be a constant error. A justification of the above assumption was made by Mr. Lee which indicated the percentage of error introduced by his assumption was very small. He calculated the weight of discharge from the fuel nozzle using the number and size of the fuel droplets collected on the smoked-glass and compared this value to the actual discharge computed by the flow formula. In each case the two values agree within fifty percent of each other. This seems to be a large error but if we consider that he collected only 0.1 percent or less of the droplets in the entire fuel spray, the error is not too great.

In his experimental work Mr. Lee derived the following conclusions: (1) By increasing the velocity of the fuel flowing through the nozzle, the number of large droplets decreases, the mean droplet size decreases, and the fuel

spray becomes more uniform, (2) A decrease in the orifice diameter also results in a more uniform fuel spray and a much smaller mean droplet size of the fuel droplets, (3) Mean droplet size of the fuel spray is only slightly affected by the density of the air into which the fuel is injected, (4) The velocity imparted to the fuel by virtue of the pressure drop through the nozzle is the most predominant factor in the atomizing of a fuel, (5) Next to the velocity, the most important factor in fuel atomization is the orifice diameter, (6) The orifice length-diameter ratio has no appreciable effect on the atomization process through a fuel atomizing nozzle.

Mr. J. Sauter, a German scientist, is considered to be one of the leading authorities in the field of atomization since his work, thus far, has been unsurpassed. In the comparison of several fuel sprays, the efficiency of atomization is expressed in terms of the so-called "Sauter-mean diameter". The "Sauter-mean diameter" may be calculated by several different methods according to the conditions under which the fuel spray is to be used. Complete treatment of these calculations is carried out in the portion of this thesis, entitled "Determining the Efficiency of Atomization".

III

THE INVESTIGATION

A- The Object of the Investigation

The object of this investigation was to determine the effect of pressure on the atomization process.

B- Description of the Test Apparatus

Several attempts were made to use each of the methods discussed in the review of literature in determining the fuel droplet size and number. It finally became evident that the only suitable means of obtaining the fuel droplet size and number would be to take a high-speed photograph of the fuel spray issuing from the nozzle. The difficulties are serious. A clear photograph of a fast moving object can be obtained by two methods: (1) by using mechanical shutters on the lens of a camera which can be opened and closed at a very rapid rate, (2) by controlling the illumination period with the camera placed in a dark room and the mechanical shutters on the lens completely open. On account of the fineness of the drops of oil and the high speed of motion, the illumination must be very brief. If a drop of oil, having a diameter $2/100$ mm, is moving with a speed of 100 meters per second, it travels the length of its diameter in

$$\frac{2}{100 \times 100 \times 10^3} = \frac{2}{10,000,000} \text{ seconds}$$

If a useful picture of such a small object is to be obtained, the length of the illumination time should be less than 10^{-7} seconds to give a clear photograph. Since a camera with a fast shutter speed is very expensive to obtain, the first method of photographing a fuel spray was disregarded in preference to the second method mentioned above. Then too, a camera with such a high shutter speed is not obtainable on the present day market. Another serious problem arises due to the different sizes of fuel droplets, therefore, each drop will cross the lens of the camera with different speeds. The larger drops of oil, on account of their smaller ratio of surface to volume, will be accelerated more slowly and, therefore, will require a greater length of time to cross the lens of the camera than the smaller fuel droplets. Thus, the photographs will show a greater number of large drops of oil than compared to the actual conditions existing in the fuel spray. To eliminate such an error would involve considerable expense and would not seem practical since the error introduced is very small.

The general layout of the equipment, used in taking the photographs on the following pages, is shown in Figure 1. Many trial runs were made to determine the best position of the camera and the light with respect to the fuel spray. It was finally decided to place the light and camera as close together as possible, thus, having a very small incident angle

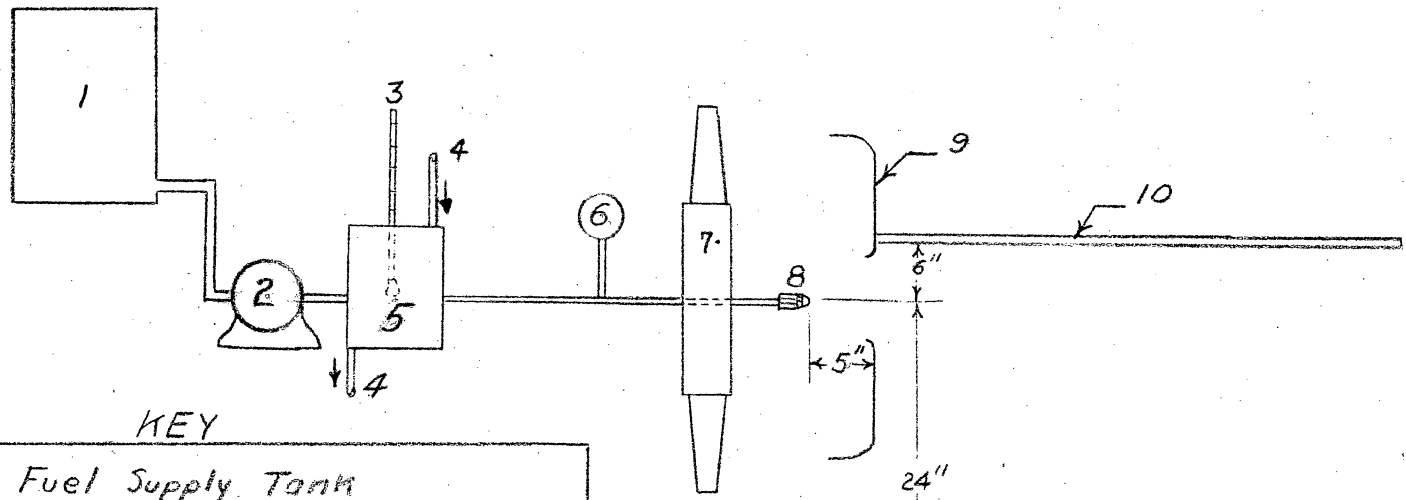

KEY

1	Fuel Supply Tank
2	Fuel Pump
3	Fuel Temperature Thermometer
4	Water Inlet & Outlet to Cooler
5	Oil Cooler
6	Fuel Pressure Gage
7	Fuel Nozzle Holder
8	Fuel Nozzle
9	Shield
10	Back Board
11	Camera
12	Photo-Flash Light

Figure 1

Schematic View of Test Equipment
 Drawn by: M.H.S. 2/27/49

of the light. This gives a very flat lighting effect and a very clear, sharp photograph. At first, this would seem to be unimportant, but remember the light which exposes the film is that light which is reflected from the fuel droplets back through the lens of the camera. The shield placed in front of the spray nozzle, as shown in Figure 1, was used to prevent fogging of the lens of the camera. In many of the trial runs it was found that the film was very foggy due to such a large volume of fuel drops. To prevent this, a shield was placed in front of the nozzle but so arranged as not to interfere with the main spray issuing from the nozzle. In this way a greater portion of the fog surrounding the fuel spray was done away with, making it possible to collect a portion of the fog behind the shield.

The high-speed photo flash light consists of the following basic parts: (1) set-up transformer (120 volts to 2000 volts), (2) electronic rectifier tube, (3) bank of electrical condensers, (4) glow lamp filled with argon gas at a low pressure. The power supplied to the primary side of the step-up transformer was regular 120 volts, 60 cycles per second, alternating current. The high voltage was taken off the secondary side of the step-up transformer and fed through an electronic rectifier tube, the resultant direct current being used to charge up the condenser bank. It took approximately fifteen seconds to charge the condenser

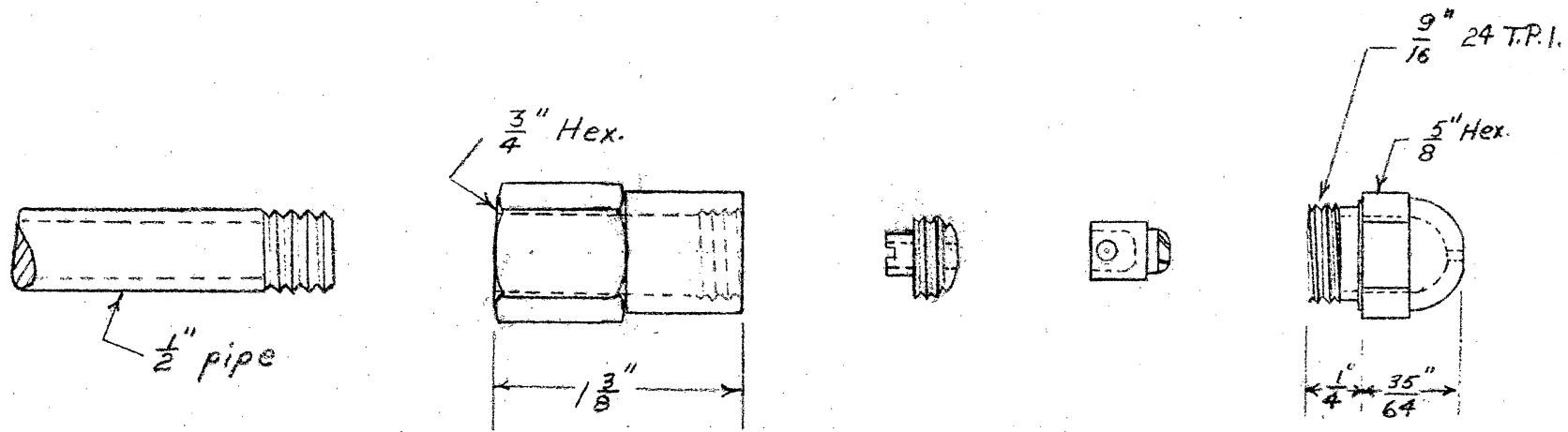

Pipe

Body

Tip Assembly

Figure 2

MONARCH NOZZLE

Oil Atomizing Nozzle, 5.5 Gallons per Hour

"Solid Cone Spray", 45 degree angle. Rated

at 100 psig fuel pressure.

Assembly Drawing of Nozzle Tested
 Drawn by: M.H.S 2/27/49

bank to 2000 volts, and then by means of an electrical switch, the stored electrical energy was discharged through the glow lamp. The glow lamp was placed in parallel across the condenser bank. The characteristics of the glow lamp are as follows: (1) ionization of the gas at 1700 volts, (2) ionization is instantaneous, (3) draws a large current, making possible the fastest discharge of the condensers, (4) no after glow from the ionization period.

The atomizing nozzle, used in the tests, was a 5.5 gallon per hour, Monarch, solid cone, 45° spray angle. A detailed drawing of this nozzle may be found in Figure 2 on Page 15.

1- List of Apparatus

Atomizer and adapter assembly - Rated at 5.5 gallons per hour at 100 psi fuel pressure, 45° spray angle, manufactured by the Monarch Mfg. Works, Inc., Philadelphia, Pa. See Figure 2.

Holder for atomizer - Manufactured in the Mechanical Engineering Laboratory of the Virginia Polytechnic Institute.

Fuel pump - Positive displacement, gear type, manufacturer unknown. Driven by a 1/3 hp, 1750 rpm, 220 volts, 3 phase, 60 cycles per second, A.C., electric motor, serial No. P L 11708, manufactured by the Master Electric Company, Dayton, Ohio.

Fuel pressure gage - 0 to 200 psi range in 2 psi increments, Bourdon type pressure gage, manufactured by the Ashcroft Company, U.S.A.

Fuel cooler - Mechanical Engineering Laboratory equipment.

Fuel temperature thermometer - 3 inch immersion, mercury column, nitrogen filled, -20°F to 120°F in 1°F increments, Eimer and Amend, New York.

Fuel tank - 5 gallon capacity, Mechanical Engineering Laboratory equipment.

High-speed photo flash light - Fabricated at Virginia Polytechnic Institute.

Camera - Speed Graphic, Graflex, manufactured by Eastman Kodak, f:4.7, 127 mm, 4 x 5 inch negatives.

Film for Camera - Triple S Pan, Anti-Halo, manufactured by Ansco Film Company, Binghamton, N.Y.

C- Method of Procedure

The arrangement of the equipment, as shown in Figure 1, was the preliminary step in the test procedure. The camera was properly adjusted, using the lens speed (f:5.0) setting which gave the best results as previously determined in the trial runs. The pump was placed in operation at the desired fuel pressure, and the oil cooler was so adjusted as to keep the oil temperature at 88°F. The bank of condensers was charged to 2000 volts, thus, placing the photo flash lamp in readiness for use. With the room completely darkened, and

the mechanical shutters of the camera opened, the bank of condensers was allowed to discharge through the glow lamp, thus, giving the illumination period for the exposure of the film. This procedure was carried out for all the desired fuel pressures on the nozzle, while the oil temperature was held constant. Upon completion of each run, the photographs were marked so as to properly identify them.

D- The Effect of Pressure on Atomization

The photographs on the following pages were taken of a fuel (Esso heating oil medium) spray issuing from a 5.5 gallon per hour, Monarch fuel atomizing nozzle. Complete details of the fuel nozzle may be found in Figure 2 on Page 15. Each photograph shows the improvement of atomization as the fuel pressure on the nozzle was increased. A comparison of Figures 3, 4, and 5 shows the change in fuel droplet size as the fuel pressure on the nozzle was increased. These photographs were taken as part of the preliminary work to determine if a project, such as this would be feasible. Figures 6, 7, 8, 9, 10, 11, 12, and 13 were taken at pressures 21, 43, 60, 82, 103, 128, 154, and 191 pounds per square inch gage respectively, which show the improvement of atomization as the pressure increases. The prevailing conditions during the taking of these photographs were as follows: constant oil temperature of 88°F, room temperature 85°F, barometric pressure 28.06 inches of mercury, and air velocity of zero. Complete treatment of these photographs will be found in the discussion of the results.

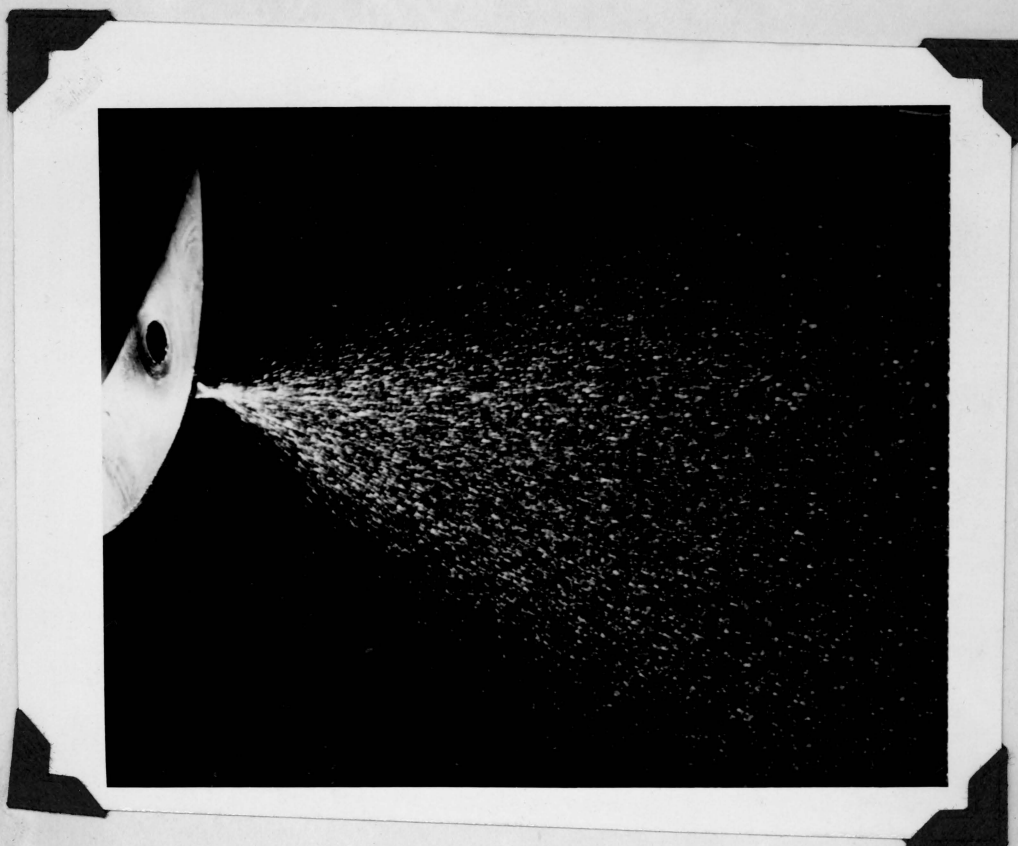

Figure 3

Oil Pressure 12 psig

Oil Temperature 88°F



Figure 4

Oil Pressure 75 psig

Oil Temperature 88°F

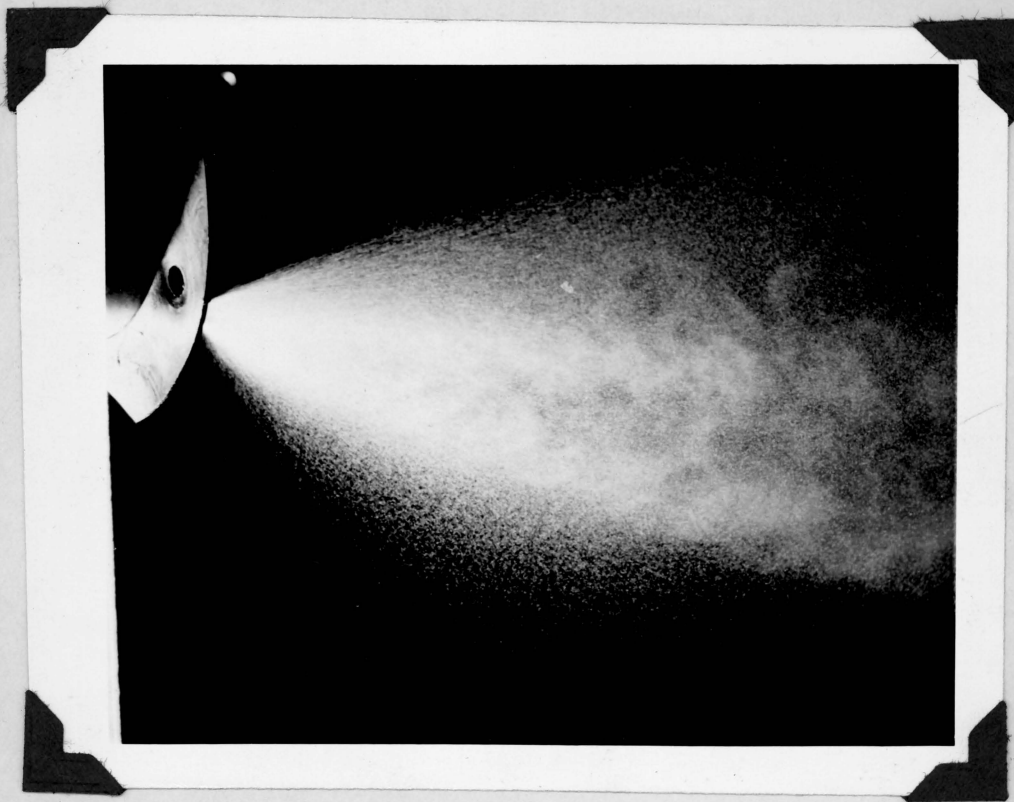

Figure 5

Oil Pressure 165 psig

Oil Temperature 88°F

Figure 6

Oil Pressure 21 psig

Oil Temperature 88°F

Nozzle Position

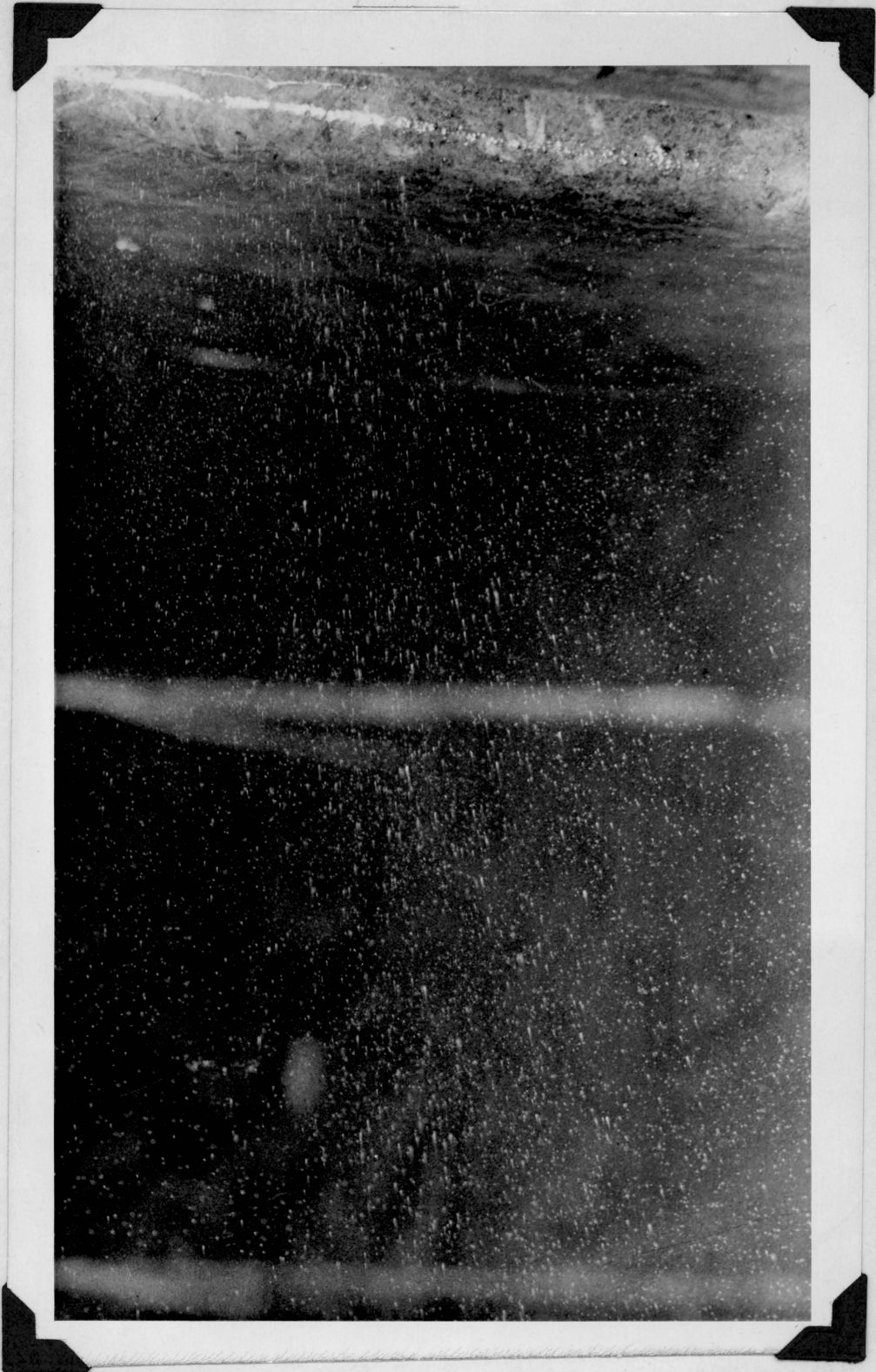

Figure 7 Oil Pressure 43 psig Oil Temperature 88°F

Nozzle Position

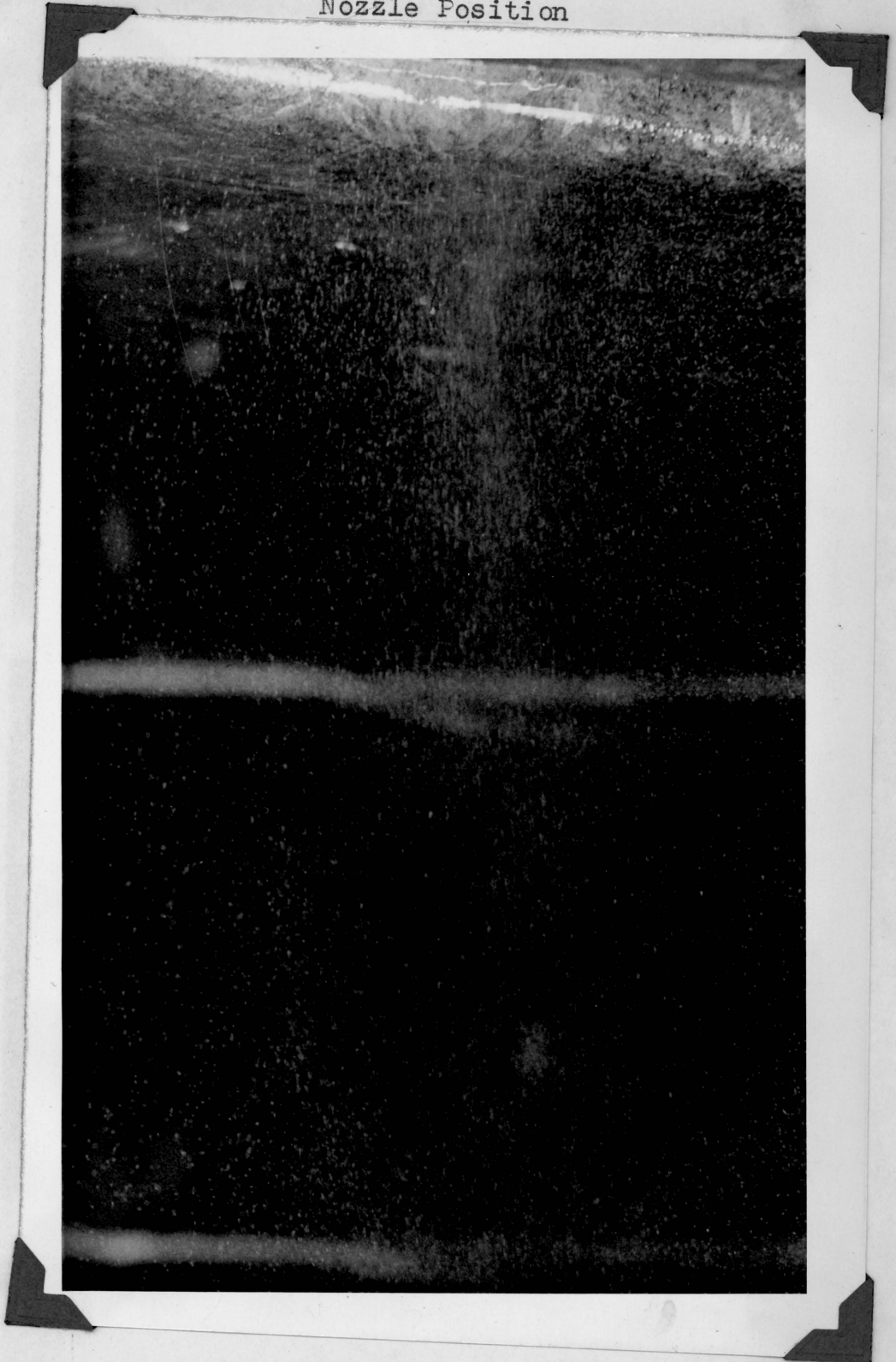

Figure 8

Oil Pressure 60 psig

Oil Temperature 88°F

Nozzle Position



Figure 9

Oil Pressure 82 psig

Oil Temperature 88°F

Nozzle Position

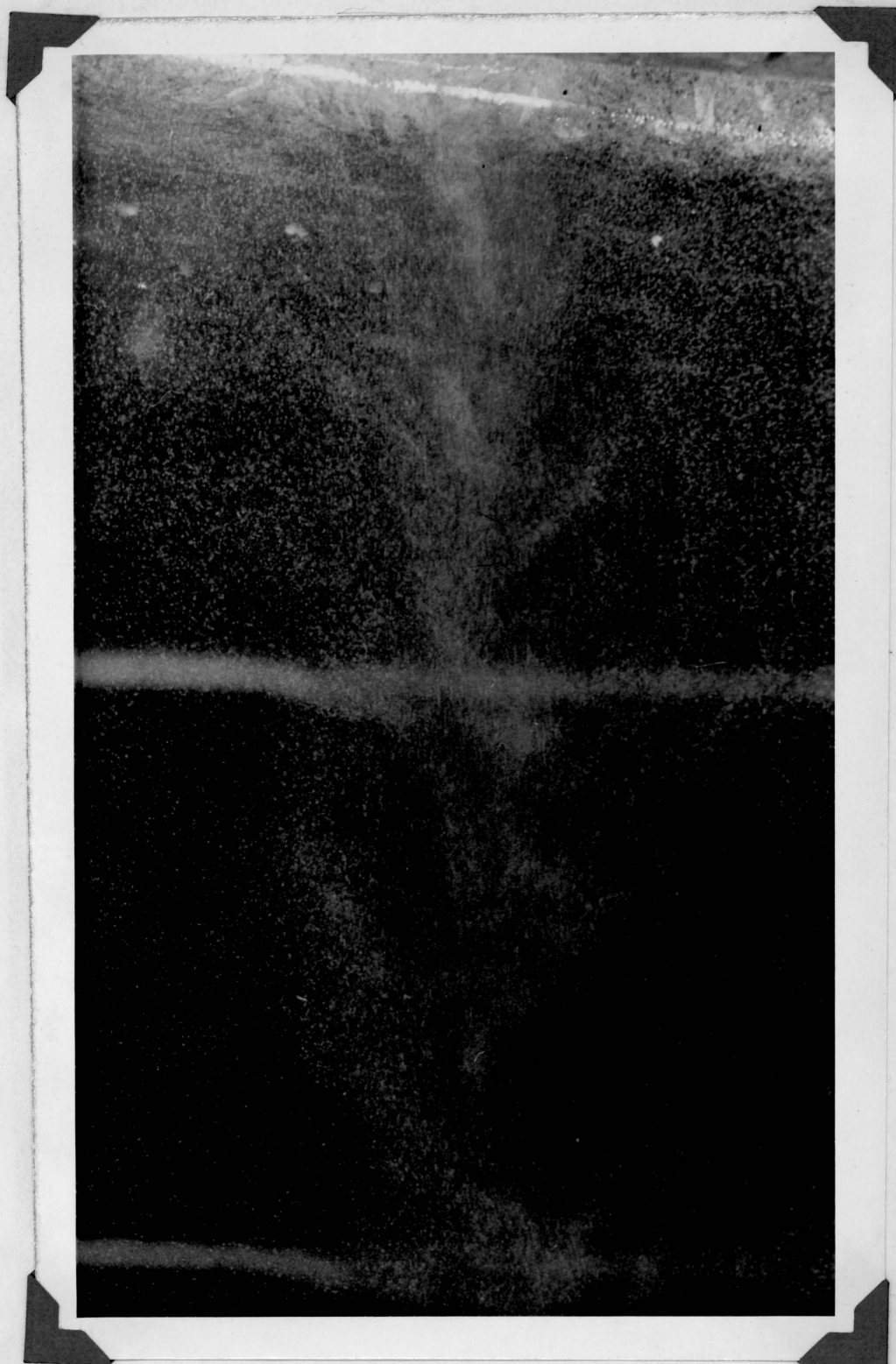

Figure 10

Oil Pressure 103 psig

Oil Temperature 88°F

Nozzle Position

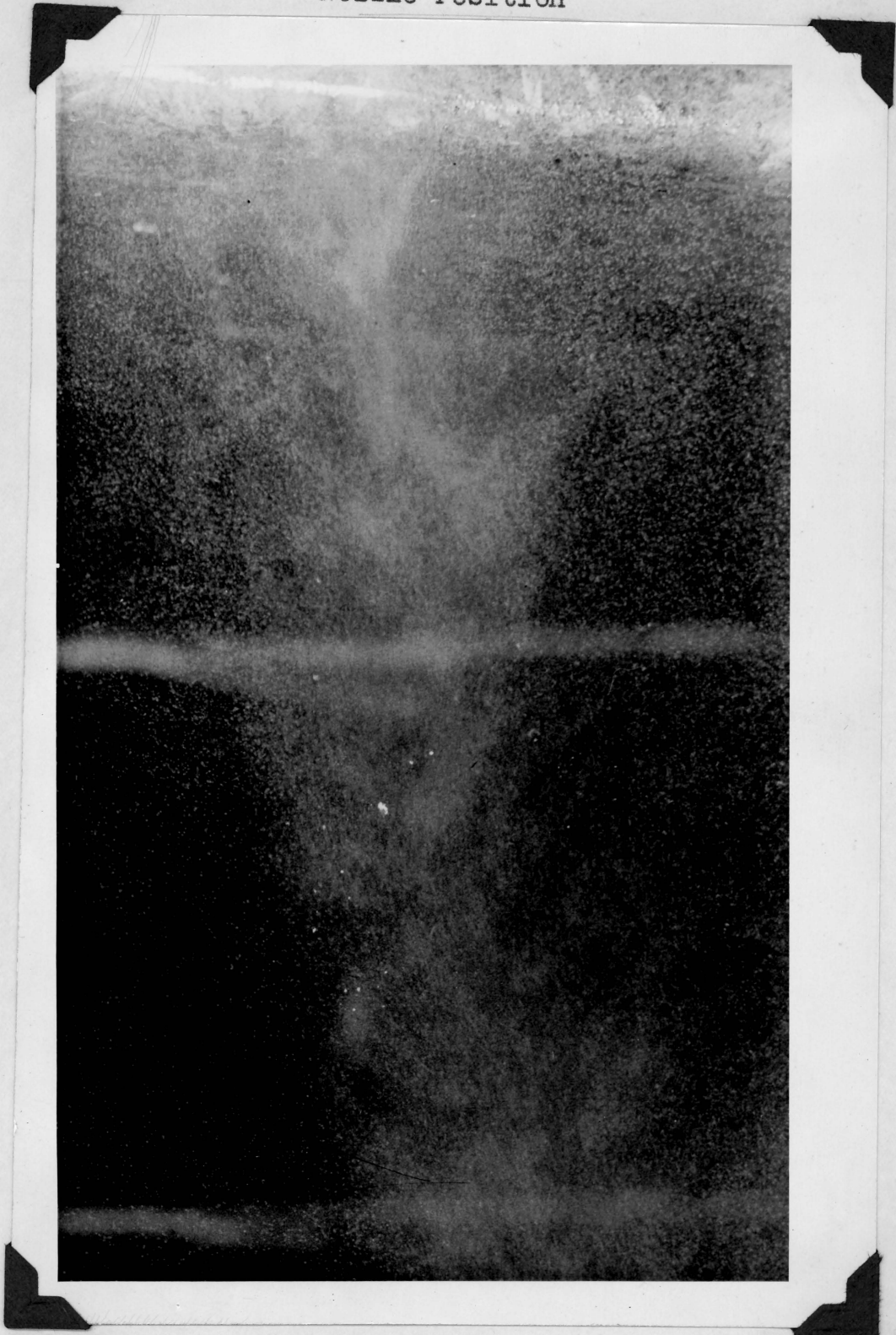

Figure 12

Oil Pressure 154 psig

Oil Temperature 88°F

Nozzle Position

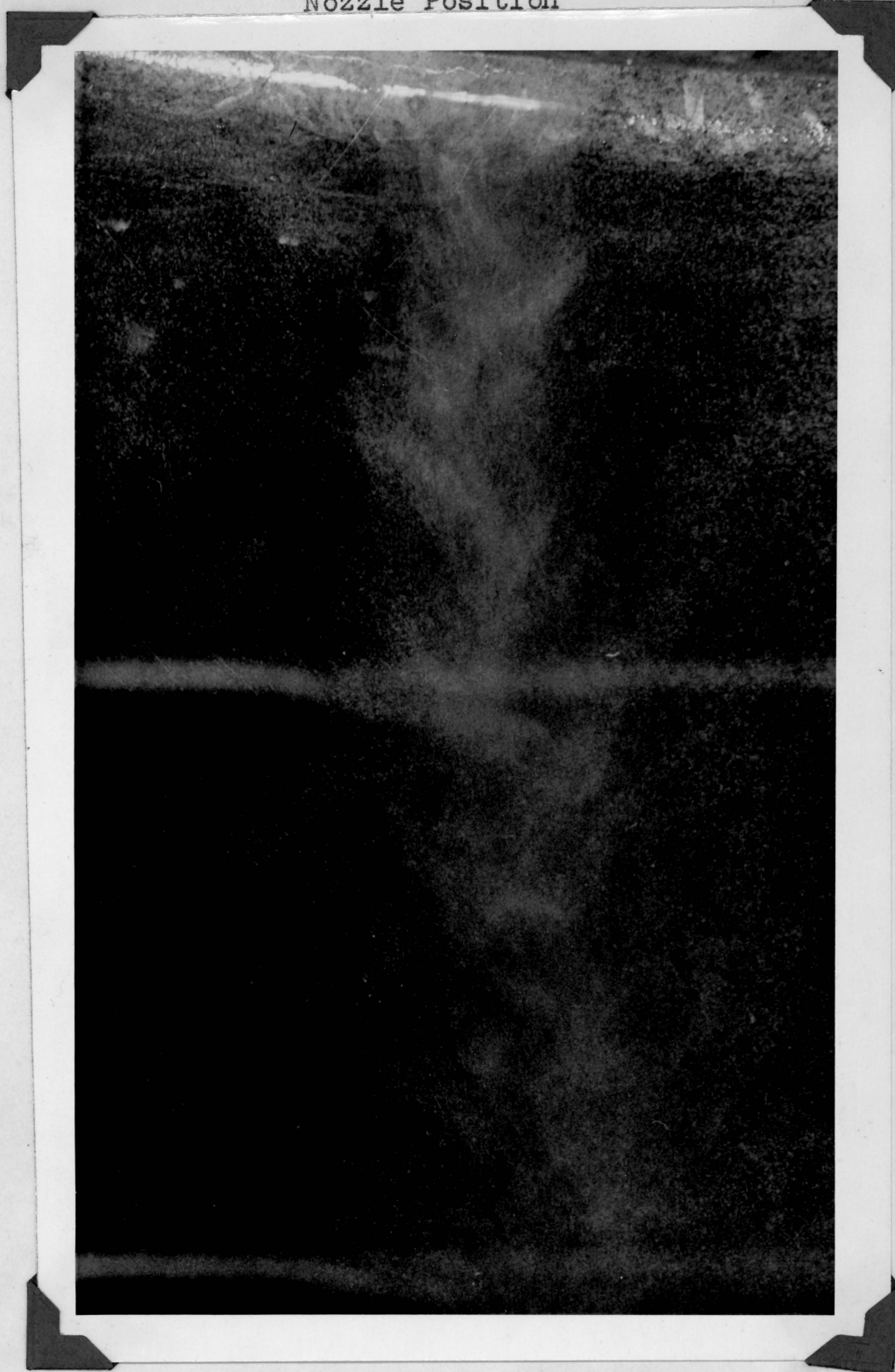

Figure 13 Oil Pressure 191 psig Oil Temperature 88°F

Nozzle Position



E- Determining the Efficiency of Atomization

The mixture of air and an atomized fuel spray will always contain drops of fuel of varying sizes and number. It is necessary to have some representative means by which a fuel spray may be classified, thus making it possible to compare several fuel sprays in regard to their degree of atomization. Since there is no hard and fast method by which the degree of atomization may be calculated, it is necessary to understand the conditions under which the fuel sprays are to be compared. Because a fuel spray contains drops of fuel of many different sizes, the object is always to determine the mean size, based upon the existing conditions of comparison. In order to obtain a criterion for the atomization of a spray, it is necessary to replace the drops of different sizes by drops of an imaginary fuel spray of a definitely defined mean size. In each of the following cases, the term, "mean radius of the fuel droplets", is considered to mean the resulting radius of the fuel droplets if the actual fuel spray were to be replaced with a perfectly uniform spray with all the droplets having the same radius equal to the "mean radius of the fuel droplets".

This method at first may indicate the uniformity of the spray is neglected, but in later discussion it will be taken into account. In comparing the atomization of several sprays, it will be necessary each time to atomize a given volume of the fuel, determine the size and number of droplets produced,

and by one or several of the following methods, the sprays may be compared as to their degree of atomization.

To aid in clarifying the ensuing discussion, the following symbols will be defined.

R_0 = mean radius of the fuel droplets of the imaginary fuel spray.

N = total number of droplets in the imaginary fuel spray.

A = total surface area of all the droplets in the imaginary fuel spray.

V = total volume of all the droplets in the imaginary fuel spray.

$n_1, n_2, n_3, \dots, n_x$ = the droplets in the actual fuel spray.

$r_1, r_2, r_3, \dots, r_x$ = radii of droplets n_1, n_2, n_3, n_x , respectively, in the actual fuel spray.

$a_1, a_2, a_3, \dots, a_x$ = surface area of droplets n_1, n_2, n_3, n_x , respectively, in the actual fuel spray.

$v_1, v_2, v_3, \dots, v_x$ = volume of droplets n_1, n_2, n_3, n_x , respectively, in the actual fuel spray.

Case I $(R_0)_1$

The most straightforward method of calculating the "mean radius of the fuel droplets" is to take the arithmetical mean of their radii. In this case the actual fuel spray can be replaced with a perfectly uniform spray, having the same number of droplets, and the sum of the radii of all the droplets in the spray are equal.

Therefore:

$$(R_0)_1 (N) = r_1 + r_2 + r_3 \dots + r_x$$
$$(R_0)_1 = \frac{r_1 + r_2 + r_3 \dots + r_x}{N} = \frac{\sum r}{\sum n}$$

Case II $(R_0)_2$

The mean radius of the fuel droplets can be calculated, based on the total area and number of droplets in the actual fuel spray. The actual fuel spray can be replaced with a perfectly uniform spray, having the same number of droplets and the same total surface area of all the droplets. This seems to be a very good method in conjunction with combustion efficiency since the surface area, available for evaporation, is a very important factor in the combustion process.

Therefore:

$$a_1 + a_2 + a_3 \dots + a_x = 4\pi r_1^2 + 4\pi r_2^2 + 4\pi r_3^2 \dots + 4\pi r_x^2$$
$$\sum a = A = 4\pi \sum (r^2)$$
$$A = 4\pi N (R_0)_2^2$$
$$(R_0)_2 = \sqrt{\frac{A}{4\pi N}} = \sqrt{\frac{4\pi \sum (r^2)}{4\pi \sum n}} = \sqrt{\frac{\sum (r^2)}{\sum n}}$$

Case III $(R_0)_3$

The actual fuel spray may be replaced with the uniform fuel spray, having the same total volume and equal number of droplets. Thus, the uniform spray and the actual spray agree in the volume of fuel and the number of droplets, but will differ in the total surface area of the droplets and, therefore, furnish very little information about the vaporization characteristics.

Therefore:

$$\begin{aligned}
 v_1 + v_2 + v_3 \dots + v_n &= 4/3 \pi r_1^3 + 4/3 \pi r_2^3 + 4/3 \pi r_3^3 \dots + 4/3 \pi r_n^3 \\
 \sum v &= V = 4/3 \pi \sum (r^3) \\
 V &= 4/3 \pi N (R_0)_3^3 \\
 (R_0)_3 &= \sqrt[3]{\frac{3V}{4 \pi N}} = \sqrt[3]{\frac{(3)4/3 \pi \sum (r^3)}{4 \pi N}} = \sqrt[3]{\frac{\sum (r^3)}{\sum (n)}}
 \end{aligned}$$

Case IV $(R_0)_4$

In this case the actual fuel spray has been replaced by the imaginary spray which has the same total volume and total surface area. Thus, the imaginary spray will differ from the actual spray by the number of droplets and the radii of these droplets, except in one case in which the imaginary spray and the actual spray are just alike, indicating a degree of uniformity.

Actual spray:

$$\begin{aligned}
 \sum a &= 4 \pi \sum (r^2) \\
 \sum v &= 4/3 \pi \sum (r^3)
 \end{aligned}$$

Imaginary spray: $A = \sum a; \quad V = \sum v$

$$V = \frac{4}{3} \pi N (R_0)_4^3$$

$$N = \frac{3V}{4 \pi (R_0)_4^3}$$

$$A = 4 \pi N (R_0)_4^2 = \frac{4 \pi (R_0)_4^2 3V}{4 \pi (R_0)_4^3} = \frac{3V}{(R_0)_4}$$

$$(R_0)_4 = \frac{3V}{A} = \frac{(3) \frac{4}{3} \pi \sum (r^3)}{4 \pi \sum (r^2)} = \frac{\sum (r^3)}{\sum (r^2)}$$

Case V $(R_0)_5$

In this case the imaginary and actual spray agree in the following values: (1) total surface areas of the droplets are equal, (2) the sum of the radii of the droplets are equal.

Therefore:

$$A = \sum a = 4 \pi \sum (r^2)$$

$$(R_0)_5 N = \sum r$$

$$N = \frac{\sum (r)}{(R_0)_5}$$

$$A = 4 \pi N (R_0)_5^2 = \frac{4 \pi (R_0)_5^2 \sum (r)}{(R_0)_5} = 4 \pi (R_0)_5 \sum (r)$$

$$(R_0)_5 = \frac{A}{4 \pi \sum (r)} = \frac{4 \pi \sum (r^2)}{4 \pi \sum (r)} = \frac{\sum (r^2)}{\sum (r)}$$

Case VI $(R_0)_6$

In this case the imaginary and actual spray agree in the following values: (1) total volume of the droplets is equal, (2) the sum of the radii of the droplets are equal.

Therefore:

$$V = \sum v = 4/3 \pi \sum (r^3)$$

$$(R_0)_6 N = \sum (r)$$

$$N = \frac{\sum (r)}{(R_0)_6}$$

$$V = 4/3 \pi N (R_0)_6^3 = \frac{4/3 \pi (R_0)_6^3 \sum (r)}{(R_0)_6} = 4/3 \pi (R_0)_6^2 \sum (r)$$

$$(R_0)_6 = \sqrt{\frac{3V}{4\pi \sum (r)}} = \sqrt{\frac{(3)4/3 \pi \sum (r^3)}{4 \pi \sum (r)}} = \sqrt{\frac{\sum (r^3)}{\sum (r)}}$$

IV

DISCUSSION OF RESULTS

The chief interest in the field of atomization today is centered more around the degree of subdivision achieved by the mechanism than with the actual fundamentals of the atomization problem itself. The accepted theory, by which atomization is accomplished, deals with the formation of fine ligaments or threads of fuel, which collapse, when the surface tension of the fuel is exceeded, thus, forming various sizes of fuel droplets. The surface of the jet of fuel leaving the nozzle is subject to slight disturbances which are caused by various conditions, such as, vibrations of the nozzle, imperfect construction of the nozzle, vortex formation in the nozzle, and the influence of the surrounding air. These disturbances, plus, the friction between the fuel and the air, cause the formation of the ligaments or threads of fuel that eventually break down into small fuel droplets. These droplets of fuel have a tendency to be thrust to the outer portion of the fuel jet, causing the center of the jet to consist mainly of the ligaments of fuel. Some evidence of this phenomenon can be seen in Figure 3 on Page 19. This photograph clearly shows the ligament of fuel near the nozzle and the smaller particles of fuel at the outer edge of the spray.

A few of the leading authorities on atomization have stated the law by which the degree of atomization varies with

respect to pressure. Mr. J. R. Joyce claims the degree of atomization varies roughly as the square root of the fuel pressure. According to Mr. Triebnigg's theory, the atomization of a fuel spray is uniform at all times. The size of the droplets varies directly as the specific gravity and surface tension of the fuel and inversely as the specific gravity of the air, the jet velocity, and the coefficient of the air resistance. Many authorities claim it is not the pressure that affects the atomization, but the velocity imparted to the fuel by virtue of the pressure drop through the nozzle. In general, the simplest means of obtaining an increase in the fuel velocity is to increase the fuel pressure. At present, attempts are being made to impart this velocity to the fuel by means of a rotating vane. Mr. Dana W. Lee of the N.A.C.A. has made a considerable number of tests on centrifugal-type sprays, and the results indicate that it is the jet velocity rather than the fuel pressure that controls the fineness and uniformity of atomization.

In comparing Figures 6, 7, and 8 in which the fuel pressures were 21, 43, and 60 psi respectively, a difference in the shape and diameter of the core, formed due to the ligaments of fuel, can be seen. The first white line down from the nozzle position in these photographs indicate the actual distance of six inches on the board behind the fuel spray. The actual distance between each successive white

line is six inches. The point on these photographs, marked nozzle position, is actually the position of the shield, but such a marking gives a relative position of the equipment. As the pressure increased, the core diameter increased, and a greater number of smaller droplets can be seen at the outer edge of this core. In all the photographs there is a general tendency of the droplet size, at the outer edge of this core, to decrease as the fuel pressure increases. This effect is very pronounced at the lower pressure ranges. Under microscopic observation this tendency can definitely be verified. Comparison of the remaining photographs will indicate a marked change in the degree of atomization as the pressure was increased. The photographs at the higher pressure ranges are very hazy due to the large number of fuel droplets present. These photographs do not give the absolute change in atomization, but they show a relative change and much can be learned from a careful study of each.

The tabulated data on the next page will aid in the discussion of the calculation of the efficiency of atomization. These formulas were derived in the portion of this thesis, entitled, "Determining the Efficiency of Atomization". Since there are six methods by which this efficiency can be calculated, the choice of method is governed by the prevailing conditions under which the atomization process is taking place. Mr. Sauter has suggested the use of Case IV in determining the

efficiency of atomization in conjunction with the combustion process of a fuel. Throughout much of the literature on atomization, these formulas are used, but still the application of these formulas is left to the discretion of the individual. In brief, some of the practical applications of these formulas are as follows: (1) determining the efficiency of atomization and its effect upon combustion, (2) determining the efficiency of atomization and to what degree it is affected by pressure, nozzle design, and fuel and air characteristics.

Case	Imaginary and Actual Spray Agree in Value	Mean Radius
1	$\sum n = N$ $\sum (r) = N(R_0)$	$(R_0)_1 = \frac{\sum (r)}{\sum n}$
2	$\sum n = N$ $\sum a = A$	$(R_0)_2 = \sqrt{\frac{A}{4\pi N}} = \sqrt{\frac{\sum (r^2)}{\sum n}}$
3	$\sum n = N$ $\sum v = V$	$(R_0)_3 = \sqrt[3]{\frac{3V}{4\pi N}} = \sqrt[3]{\frac{\sum (r^3)}{\sum n}}$
4	$\sum v = V$ $\sum a = A$	$(R_0)_4 = \frac{3V}{A} = \frac{\sum (r^3)}{\sum (r^2)}$
5	$\sum a = A$ $\sum (r) = N(R_0)$	$(R_0)_5 = \frac{A}{4\pi \sum (r)} = \frac{\sum (r^2)}{\sum (r)}$
6	$\sum v = V$ $\sum (r) = N(R_0)$	$(R_0)_6 = \sqrt{\frac{3V}{4\pi \sum (r)}} = \sqrt{\frac{\sum (r^2)}{\sum (r)}}$

CONCLUSIONS

The following conclusions were formed from this investigation:

- A. Fuel pressure definitely affects the degree of atomization within the range of fuel pressures (20 to 191 psi) tested in this investigation. By increasing the fuel pressure, the droplet size decreased, and the uniformity of the spray increased.
- B. Photography is the best means to determine the fuel droplet size. Although this requires the use of excellent equipment, this method proved to be the most satisfactory means of obtaining a definite picture of the process of atomization.
- C. The efficiency of atomization can be calculated if the size and number of fuel droplets in a given spray is known.

VI

RECOMMENDATIONS

There are still many unsolved problems concerning the process of atomization. This investigation showed the relative change of atomization as the fuel pressure was increased. With the proper photographic equipment, the absolute fuel droplet size could be determined, and the efficiency of atomization could be calculated. This leads to the following recommendations:

- (1) A thorough study could be made of the photographic equipment at N.A.C.A., Langley Field, Va. From this investigation, the construction of their equipment could be duplicated at Virginia Polytechnic Institute, Mechanical Engineering Laboratory.
- (2) A study could be made of the feasibility of purchasing a measuring microscope with photographic attachments and a high-speed photo flash lamp for high-speed photography.
- (3) With the above equipment, a thorough investigation of the process of atomization can be made.
- (4) Investigation of the effect of design characteristics on the fuel atomization process.

If these recommendations were carried out, many fields of research would be opened to work at Virginia Polytechnic

Institute, Mechanical Engineering Laboratory. The study of the flow characteristics of fluids and gases have been carried out by the use of microscopic photography. Many other processes, involving rapid motion and small particle sizes, have been studied by this method.

VII

ACKNOWLEDGEMENTS

The author would like to take this opportunity to thank Prof. J. B. Jones for his aid and encouragement in performing this investigation; to Professors D. Miller and H. Wood for their constructive criticism and the use of portions of their combustion chamber equipment.

APPENDIX I
BIBLIOGRAPHY

- (1) Beardsley, E. G. and Rothrock, A. M.: Some Effects of Air Flow on the Penetration and Distribution of Oil Sprays. T.N. No. 329, N.A.C.A., December, 1929.
- (2) Castleman, R. A., Jr.: The Mechanism of the Atomization of Liquids. Page 369 of U.S. Bureau of Standards, Journal of Research, Vol. 6, January-June, 1931, RP259-328.
- (3) DeJuhasz, Kalman J., Schweitzer, P. H., and Zahn, O. F.: The Formation and Dispersion of Oil Sprays. Bulletin 40 of the Pennsylvania State College School of Engineering Technical Bulletins.
- (4) Doble, S. M.: Design of Spray Nozzles. Page 21 of Engineering, Vol. 159, January-June, 1945.
- (5) Edgerton and Killian: Flash! Seeing the Unseen by Ultra High-Speed Photography.
- (6) Gelalles, A. G.: Effect of Orifice Length-Diameter Ratio on Spray Characteristics. T. M. No. 352, N.A.C.A., October, 1930.
- (7) Gelalles, A. G.: Some Effects of Air and Fuel Oil Temperatures on Spray Penetration and Dispersion. T. N. No. 338, N.A.C.A., May, 1930.
- (8) Gibbons, Louis C. and Jonash, Edmund R.: Effect of Fuel Properties on the Performance of the Turbine Engine Combustor. Advance Copy, Paper No. 48-A-104, The

American Society of Mechanical Engineers.

- (9) Haenlein, A.: Disintegration of a Liquid Jet. T. M. No. 659, N.A.C.A., February, 1932.
- (10) Hausfelder, Ludwig: High-Speed Oil Engines for Vehicles, Part I-Engines with External Atomization of the Fuel, Engines with Internal Atomization of the Fuel, Hot-Bulb Engines, Diesel Engines. T. M. No. 397, N.A.C.A., February, 1927.
- (11) Joachim, W. F.: Oil-Spray Investigation of the N.A.C.A. Page 45, Bulletin 5 of the Pennsylvania State College School of Engineering Technical Bulletins.
- (12) Lee, D. W. and Rothrock, A. M.: Some Characteristics of Fuel Sprays from Open Nozzles. T. M. No. 356, N.A.C.A., November, 1930.
- (13) Lee, D. W.: The Effect of Nozzle Design and Operating Conditions on the Atomization and Distribution of Fuel Sprays. Eighteenth Annual Report, N.A.C.A., 1932, Report 425.
- (14) Lichty, L. C.: Internal Combustion Engines. Pages 229-241.
- (15) Lloyd, Peter: Combustion in the Gas Turbine. Pages 462-472 of Development of the British Gas Turbine Jet Unit, published by The Institution of Mechanical Engineers, London, England.
- (16) Mack, J. E. and Martin, M. J.: The Photographic Process.

- (17) Miller, Cearcy D.: Slow-Motion Study of Injection and Combustion of Fuel in a Diesel Engine. Aircraft-Engine Research Laboratory, N.A.C.A. S.A.E. Journal, Vol. 53, 1945.
- (18) Rothrock, A. M. and Waldren, C. D.: Some Characteristics of Fuel Sprays at Low-Injection Pressures. T. M. No. 399, N.A.C.A., November, 1931.
- (19) Sauter, J.: Determining the Efficiency of Atomization by its Fineness and Uniformity. T. M. No. 396, N.A.C.A., "Forschungsarbeiten auf dem Gebiete des Ingenieurwesens", No. 279, 1926.
- (20) Scheubel, F. N.: On Atomization in Carburetors. T. M. No. 644, N.A.C.A., October, 1931.
- (21) Schweitzer, P. H.: Factors in Diesel Spray-Nozzle Design in the Light of Recent Oil-Spray Research. Page 29, Bulletin 12 of the Pennsylvania State College School of Engineering Technical Bulletins.
- (22) Spanogle, J. A. and Foster, H. H.: Performance of a High-Speed Compression-Ignition Engine, Using Multiple Orifice Fuel Injection Nozzles. T. M. No. 344, N.A.C.A., June, 1930.
- (23) Stranathan: The Particles of Modern Physics. Page 49.