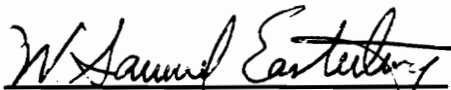

**THE LOAD DEFORMATION RESPONSE
OF
SINGLE BOLT CONNECTIONS**

by
Burak Karsu

Thesis submitted to the faculty of the
Virginia Polytechnic Institute and State University
in partial fulfillment of the requirements for the degree of
MASTER OF SCIENCE
in Civil Engineering

APPROVED:

W. Samuel Easterling, Chairman

Don A. Garst

Richard M. Barker

September 1995

Blacksburg, Virginia 24061

c.2

LD
5055
Y855
1995
K377
c.2

**THE LOAD-DEFORMATION RESPONSE
OF
SINGLE BOLT CONNECTIONS**

by

Burak Karsu

Committee Chairman: W. Samuel Easterling
Civil Engineering

(ABSTRACT)

Sophisticated design techniques such as partially restrained connections need detail information on the load-deformation response of bolted connections. The behavior of single bolt, single shear connections are studied. Seventy tests with different configurations were conducted to evaluate their failure mechanisms and load-deformation characteristics. Comparisons to previous study were made. A new analytical model for the determination of load-deformation response of bolted connections was presented as well as a new Unified Design Curves approach for design purposes. It has been proven that this generalized method can be used efficiently.

ACKNOWLEDGMENTS

I would like to thank Dr. W. Samuel Easterling, Don A. Garst, and Dr. Richard M. Barker for their assistance and guidance in this thesis.

I also want to thank Clinton O. Rex for his close attention to all the things included in this research project. I would like to extend my gratitude to my friends with whom I shared Structural Engineering Laboratory.

My special thanks go to Dennis Huffman and Brett Farmer for their great efforts in preparing my specimens.

It would take a million words to express my feelings for my family who made this dream come true. Without you, I would not be where and what I am now. A very special thank you goes to my sweetheart who supported me in this part of my education and waited for me patiently. Life is better with you.

TABLE OF CONTENTS

ABSTRACT.....	ii
ACKNOWLEDGMENTS.....	iii
LIST OF FIGURES.....	iiix
LIST OF TABLES.....	x
CHAPTER 1 INTRODUCTION.....	1
1.1 GENERAL.....	1
1.2 LITERATURE REVIEW.....	2
1.2.1 Fisher (1965).....	3
1.2.2 Kulak and Crawford (1971).....	8
1.2.3 Richard, Gillett, Kriegh and Lewis (1980).....	12
1.3 CURRENT DESIGN PROCEDURE.....	18
1.3.1 Major Failure Modes in Bolted Connections.....	21
1.3.1.1 Shearing Failure of Plate.....	21
1.3.1.2 Shearing Failure of Bolt.....	24
1.4 SCOPE OF RESEARCH.....	26
CHAPTER 2 EXPERIMENTAL INVESTIGATION.....	28
2.1 GENERAL.....	28
2.2 TEST SPECIMENS.....	28
2.2.1 Plates.....	28

2.2.2 Bolts.....	29
2.3 INSTRUMENTATION.....	30
2.4 TEST SETUP AND TESTING PROCEDURE.....	31
2.5 TEST MATRIX.....	35
CHAPTER 3 TEST RESULTS.....	38
3.1 GENERAL.....	38
3.2 1/8-in. PLATE COMBINATIONS.....	38
3.2.1 3/4-in. Diameter Bolts.....	39
3.2.2 7/8-in Diameter Bolts.....	40
3.3 1/4-in. PLATE COMBINATIONS.....	41
3.3.1 3/4-in. Diameter Bolts.....	41
3.3.2 7/8-in. Diameter Bolts.....	42
3.3.3 1-in. Diameter Bolts.....	44
3.4 3/8-IN. COMBINATIONS.....	45
3.4.1 3/4-in Diameter Bolt.....	45
3.4.2 7/8-in. Diameter Bolt.....	48
3.4.3 1-in Diameter Bolt.....	50
3.5 1/2-IN. COMBINATIONS.....	52
3.5.1 3/4-in. Diameter Bolt.....	52
3.5.2 7/8-in Diameter Bolt.....	54
3.5.3 1-in. Diameter Bolt.....	56

3.6	5/8-IN. COMBINATIONS.....	58
3.6.1	3/4-in. Diameter Bolt.....	58
3.6.2	1-in. Diameter Bolt.....	60
3.7	3/4-IN. COMBINATIONS.....	61
3.7.1	7/8-in. Diameter Bolt.....	61
3.7.2	1-in. Diameter Bolt.....	63
3.8	1-IN. COMBINATIONS.....	64
3.8.1	3/4-in. Diameter Bolt.....	64
3.8.2	7/8-in. Diameter Bolt.....	66
3.8.3	1-in. Diameter Bolt.....	67
3.9	TESTS WITH REDUCED EDGE DISTANCE $L_e=1.5d_b$	68
3.10	DISCUSSION OF TEST RESULTS.....	69
3.11	GENERAL BEHAVIOR OF A BOLTED CONNECTION.....	70
3.12	LOAD-DEFORMATION CURVE.....	72
3.12.1	Elastic Region (Initial Slope and Linear Elastic Portion).....	72
3.12.2	Yielding Region.....	74
3.12.3	Plastic Region.....	75
3.13	ANALYTICAL MODELS.....	75
3.13.1	Load-Deformation Models.....	75
3.13.1.1	AISC Model.....	76
3.13.1.2	Richard's Model.....	79
3.13.2	Strength Models.....	81

3.13.2.1 Bearing/Tear Out and Splitting.....	81
3.13.2.2 Bolt Shear Model.....	85
CHAPTER 4 LOAD vs. DEFORMATION STUDY.....	88
4.1 GENERAL.....	88
4.2 THE KARSU EQUATION.....	88
4.3 NORMALIZED LOAD-DEFORMATION CURVES.....	89
4.3.1 The Analytical Models.....	97
4.4 UNIFIED DESIGN CURVES.....	104
CHAPTER 5 SUMMARY, CONCLUSIONS AND RECOMMENDATIONS.....	111
5.1 SUMMARY.....	111
5.2 CONCLUSIONS.....	113
5.3 RECOMMENDATIONS.....	115
REFERENCES.....	116
APPENDIX A Nomenclature.....	117
APPENDIX B Measured Material Properties.....	121
APPENDIX C Summaries of the Tests.....	124
VITA.....	325

LIST OF FIGURES

Figure 1.2-1 Idealized Stress-Strain Relationship.....	6
Figure 1.2-2 Load-Deformation Response Of Bolts.....	8
Figure 1.3-1 Shear Failure Of Bolt.....	19
Figure 1.3-2 Shear Failure Of Plate.....	19
Figure 1.3-3 Bearing Failure Of Bolt.....	19
Figure 1.3-4 Bearing Failure Of Plate.....	20
Figure 1.3-5 Bending Failure Of Bolt.....	20
Figure 1.3-6 Transverse Tension Failure Of The Plate.....	20
Figure 1.3-7 Splitting Failure Of Plate.....	20
Figure 1.3-8 Tension Failure Of Bolt.....	21
Figure 1.3-9 Bearing Strength Related To Edge Distance.....	21
Figure 2.2-1 Test Specimen.....	29
Figure 2.3-1 General Instrumentation.....	31
Figure 2.4-1 General View Of Test Setup.....	33
Figure 2.4-2 Behavior Of A Bolted Connection With Slippage.....	34
Figure 3.2-1 Data Overlay Of 1/8-In. Combinations With 3/4-In. Bolts.....	40
Figure 3.2-2 Data Overlay Of 1/8-In. Combinations With 7/8-In. Bolts.....	41
Figure 3.3-1 Initial Stiffness Of 1/4-In. Combinations With 7/8-In Bolts.....	43
Figure 3.3-2 Data Overlay Of 1/4-In. Combinations With 7/8-In Bolts.....	44
Figure 3.3-3 Initial Stiffness Of 1/4-In. Combinations With 1-In. Bolts.....	45
Figure 3.3-4 Data Overlay Of 1/4-In. Combinations With 1-In Bolts.....	46
Figure 3.4-1 Initial Stiffness Of 3/8-In. Combinations With 3/4-In Bolts.....	47
Figure 3.4-2 Data Overlay Of 3/8-In. Combinations With 3/4-In Bolts.....	48
Figure 3.4-3 Initial Stiffness Of 3/8-In. Combinations With 7/8-In. Bolts.....	49
Figure 3.4-4 Data Overlay Of 3/8-In. Combinations With 7/8-In Bolts.....	50
Figure 3.4-5 Initial Stiffness Of 3/8-In. Combinations With 1-In. Bolts.....	50
Figure 3.4-6 Data Overlay Of 3/8-In. Combinations With 1-In Bolts.....	50
Figure 3.5-1 Initial Stiffness Of 1/2-In. Combinations With 3/4-In. Bolts.....	53
Figure 3.5-2 Data Overlay Of 1/2-In. Combinations With 3/4-In Bolts.....	54
Figure 3.5-3 Initial Stiffness 1/2-In. Combinations With 7/8-In. ..Bolts.....	55
Figure 3.5-4 Data Overlay Of 1/2-In. Combinations With 7/8-In Bolts.....	56
Figure 3.5-5 Initial Stiffness Of 1/2-In. Combinations With 1-In. Bolts.....	57
Figure 3.5-6 Data Overlay Of 1/2-In. Combinations With 1-In Bolts.....	57
Figure 3.6-1 Initial Stiffness Of 5/8-In. Combinations With 3/4-In. Bolts.....	58
Figure 3.6-2 Data Overlay Of 5/8-In. Combinations With 3/4-In Bolts.....	59
Figure 3.7-1 Initial Stiffness Of 3/4-In. Combinations With 7/8-In. Bolts.....	60
Figure 3.7-2 Data Overlay Of 3/4-In. Combinations With 7/8-In Bolts.....	61
Figure 3.7-3 Data Overlay Of 3/4-In. Combinations With 1-In Bolts.....	62
Figure 3.8-1 Initial Stiffness Of 1-In. Combinations With 3/4-In. Bolts.....	64
Figure 3.8-2 Data Overlay Of 1-In. Combinations With 3/4-In. Bolts.....	66

Figure 3.8-3 Data Overlay Of 1-In. Combinations With 7/8-In. Bolts.....	67
Figure 3.8-4 Data Overlay Of 1-In. Combinations With 1-In. Bolts.....	68
Figure 3.9-1 Data Overlay Of Tests With $L_e=1.5d_b$	69
Figure 3.11-1 General Behavior Of Bolted Connections.....	70
Figure 3.13-1 Comparison Of Test Data With AISC Model.....	77
Figure 3.13-2 Comparison Of Test Data With AISC Model.....	77
Figure 3.13-3 Comparison AISC Equation With 1/8-In. Combination Data.....	78
Figure 3.13-4 Comparison Of Richard's Test Data With Our Data (Bearing/Tearout).....	80
Figure 3.13-5 Comparison Of Richard's Test Data With Our Data (Bolt Shear).....	81
Figure 4.3-1 Normalized 1/8-In. Combinations W/ 3/4-In. Bolt.....	91
Figure 4.3-2 Normalized 1/8-In. Combinations W/ 7/8-In. Bolt.....	92
Figure 4.3-3 Normalized 1/4-In. Combinations W/ 3/4-In. Bolt.....	92
Figure 4.3-4 Normalized 1/4-In. Combinations W/ 7/8-In. Bolt.....	93
Figure 4.3-5 Normalized 1/4-In. Combinations W/ 1-In. Bolt.....	93
Figure 4.3-6 Normalized 3/8-In. Combinations W/ 7/8-In. Bolt.....	94
Figure 4.3-7 Normalized 3/8-In. Combinations W/ 1-In. Bolt.....	94
Figure 4.3-8 Normalized Bolt Shear Tests.....	96
Figure 4.3-10 Comparison Of $1.5d_b$ And $2.0d_b$ Tests.....	96
Figure 4.4-1 1/8-In. Combinations Normalized Data.....	104
Figure 4.4-2 Unified Design Curves For 1/8-In. Combinations.....	105
Figure 4.4-3 1/4-In. Combinations Normalized Data.....	106
Figure 4.4-4 Unified Design Curves For 1/4-In. Combinations.....	107
Figure 4.4-5 3/8-In. Combinations Normalized Data	109

Figure 3.8-3 Data Overlay Of 1-In. Combinations With 7/8-In. Bolts.....	67
Figure 3.8-4 Data Overlay Of 1-In. Combinations With 1-In. Bolts.....	68
Figure 3.9-1 Data Overlay Of Tests With $L_c=1.5d_b$	69
Figure 3.11-1 General Behavior Of Bolted Connections.....	70
Figure 3.13-1 Comparison Of Test Data With AISC Model.....	77
Figure 3.13-2 Comparison Of Test Data With AISC Model.....	77
Figure 3.13-3 Comparison AISC Equation With 1/8-In. Combination Data.....	78
Figure 3.13-4 Comparison Of Richard's Test Data With Our Data (Bearing/Tearout).	80
Figure 3.13-5 Comparison Of Richard's Test Data With Our Data (Bolt Shear).....	81
Figure 4.3-1 Normalized 1/8-In. Combinations W/ 3/4-In. Bolt.....	91
Figure 4.3-2 Normalized 1/8-In. Combinations W/ 7/8-In. Bolt.....	92
Figure 4.3-3 Normalized 1/4-In. Combinations W/ 3/4-In. Bolt.....	92
Figure 4.3-4 Normalized 1/4-In. Combinations W/ 7/8-In. Bolt.....	93
Figure 4.3-5 Normalized 1/4-In. Combinations W/ 1-In. Bolt.....	93
Figure 4.3-6 Normalized 3/8-In. Combinations W/ 7/8-In. Bolt.....	94
Figure 4.3-7 Normalized 3/8-In. Combinations W/ 1-In. Bolt.....	94
Figure 4.3-8 Normalized Bolt Shear Tests.....	96
Figure 4.3-10 Comparison Of $1.5d_b$ And $2.0d_b$ Tests.....	96
Figure 4.4-1 1/8-In. Combinations Normalized Data.....	104
Figure 4.4-2 Unified Design Curves For 1/8-In. Combinations.....	105
Figure 4.4-3 1/4-In. Combinations Normalized Data.....	106
Figure 4.4-4 Unified Design Curves For 1/4-In. Combinations.....	107
Figure 4.4-5 3/8-In. Combinations Normalized Data	109

LIST OF TABLES

Table 1.2-1 Summary Of Test Results (Fisher).....	8
Table 1.2-2 Curve Parameters Of Richard's Tests.....	15
Table 1.2-3 D/T Ratios.....	17
Table 1.2-4 Maximum Web Or Plate Thicknesses.....	17
Table 2.5-1 Preliminary Test Matrix.....	35
Table 2.5-2 Test Matrix.....	36
Table 3.12-1 K And K_p Values Of Individual Tests.....	73
Table 3.13-1 Comparison Of Test Load Values With The Predicted Values (B/T).....	83
Table 3.13-2 Comparison Of Test Load Values With The Predicted Values (Splitting).....	84
Table 3.13-3 Comparison Of Test Load Values With The Predicted Values (1/8-In. Comb.).....	85
Table 3.13-4 Comparison Of Bolt Shear Test Values With Predicted Values.....	87
Table 4.3-1 AISC Model Parameters.....	98
Table 4.3-2 Karsu Model Parameters.....	100
Table 4.3-3 Richard's Model Parameters.....	102
Table 4.4-1 Parameters Of Load-Deformation Models For Unified Design Curve Of 1/8-In. Combinations.....	106
Table 4.4-2 Parameters Of Load-Deformation Models For Unified Design Curve Of 1/4-N. Combinations.....	107
Table 4.4-3 Parameters Of Load-Deformation Models For Unified Design Curve Of 3/8-In. Combinations.....	108
Table 4.4-4 Parameters Of Load-Deformation Models For Unified Design Curve Of Bolt Shear Failures.....	110

CHAPTER 1

INTRODUCTION

1.1 GENERAL

Steel construction is one of the most widely used construction techniques in the world. The reliability and high load carrying capacity to weight ratio of steel encourages its use in structural engineering projects. Today's design techniques and high-strength steels enable engineers to build multi-story buildings as well as economical low-rise structures.

As with all things that exist in this world, steel has its own way of behavior when subjected to the specified loads. The most essential part of the design process is having some idea of this behavior. Engineers frequently ask if the optimum solution to the problem has been reached-- this question can only be solved by knowing how the structure behaves in response to loads. A critical part of understanding the behavior of a structure is understanding the behavior of the connections.

No matter what we are designing, the structure is an assembly of individual parts. Connections are what we use to fasten those parts. That gives connections a role of great importance because no matter how strong the beams or the columns, connections have to

be strong enough to carry their load. None of these parts of steel construction can exist without the other.

Bolts, rivets or welds have been used as fasteners in steel connections for a long time; therefore, the interaction between the fasteners and the connected elements has been investigated for many years also. As time passed and design techniques got sophisticated, engineers needed more basic insight into the phenomenon of connecting parts. This brought about the need for more accurate estimations of the behavior. Some assumptions in these estimations have been proven to be solvable, so researchers tried to come up with better ways of understanding the actual behavior of the connections. This study is another step in this learning process.

Bolted connections are the most widely used system to connect elements of steel construction because of their practical and simple installation. On the other hand, the information on their behavior is somewhat incomplete and insufficient. More generalization of this information seems to be required in today's design techniques. The research described in this thesis deals with determining the characteristics of bolted connections as well as making practical recommendations on their design.

1.2 LITERATURE REVIEW

The literature review section of this thesis reviews the research that was done and gives insight view into these works to provide a background for understanding the problem better. The focus of this project is on the load-deformation response and

strength of bolted connections; therefore the literature review is also focused on these specific areas of work.

1.2.1 Fisher (1965)

Fisher considered both analytical and experimental investigations of behavior of the fasteners and plates with holes. He dealt with the actual relationship between stress and strain in the perforated plates, as well as the load-deformation response of the bolted connections. A mathematical model was introduced to predict this relationship. Also, the stiffness of the connected plates was investigated.

Although some reports have been published by Francis (1953), Rumpf (1960), and Fisher (1964) on the elastic and inelastic response of riveted and bolted joints, there were still large gaps between the actual behavior and the properties of the joints. Fisher's study intended to develop analytical expressions to represent the load-deformation relationship as a function of material and geometric properties. To achieve these goals a series of tests were conducted at the Fritz Engineering Laboratory at Lehigh University. The study contained carbon steels such as A7 and A36, high-strength steel such as A440, and high strength low alloy steel such as A242 and A441. The fasteners were A325 high-strength bolts, A141 steel rivets and A490 high-strength bolts.

The study began with an investigation of the stress-strain relationship of the joint plates with holes. These kinds of plates are basic parts of mechanically- fastened joints. Tensile specimens were cut from the materials to be used in the tests and holes of the

same size as the subsequent tests were drilled. Specimens without holes were also prepared. Two different stress-strain relationships were observed for the two types of specimens. Both had the same yield stresses, but the specimen with holes did not have a significant yield plateau and had slightly higher ultimate strength. On the other hand, the specimen without holes had a greater ductility when compared to the one with the holes.

Some studies done by Baud and Wahl (1930) indicated that the elastic stress distribution around the holes results in high stress points on the boundary of the holes. First yield appeared to be at the points of peak stress around the hole. Nadai (1950) showed that as the load was increased, yielding spreaded in two narrow strips located symmetrically with respect to the axis of the load at 45° .

Fisher tabulated the major variables influencing the stress-strain relationship as:

1. The width or gage of the plate, g ;
2. The diameter of the hole, d ;
3. The spacing between the holes, p ;
4. The yield point of the coupon, σ_y ;
5. The ultimate tensile strength of the coupon. σ_u ;
6. The type of steel;
7. The speed of testing.

The following assumptions were made in Fisher's study in order to create a model for the required relationship:

1. The stress-strain curve has a constant initial slope,
2. The inelastic part of the stress-strain curve is based on the dynamic measurements,

3. Stress increases in a decreasing speed in the region where $\epsilon_y > \epsilon > \epsilon_u$.

Hooke's Law applies for the elastic portion of curve.

$$\sigma = \epsilon E \quad (\text{Eq. 1.2-1})$$

where $\epsilon < \epsilon_y$ and $\sigma = P / A_g$.

As the stress is increased after the yielding point the linear relationship does not apply for the rest of the curve and a new expression has to be determined for the relationship between stress and strain.

The expression that Fisher has chosen for that purpose is:

$$\sigma = E\epsilon_y + K(1 - e^{-\alpha\epsilon})^\beta \quad (\text{Eq. 1.2-2})$$

in which σ = average stress on the net area in ksi; α , β , K = empirical parameters;

e = base of natural logarithm; ϵ = strain in the specimen; ϵ_y = inelastic strain.

As the purpose of the study was to determine general expressions the proposed equation had to be generalized so that one could predict the response with different materials and different geometric properties. Figure 1.2-2 shows the idealized stress-strain relationship based on Eq. 1.2-2. The parameters of the equation were determined by regression analysis which best fit the data obtained from the earlier tests. Fisher also conducted another study where α , β , K were determined using the boundary conditions.

$K = \sigma_u - \sigma_y$ where σ_u = ultimate tensile strength at net section and σ_y = yield stress at net section.

$\alpha = (\sigma_u - \sigma_y)A_g/A_n$ and β was found to be 3/2 as a constant for the materials used in the tests.

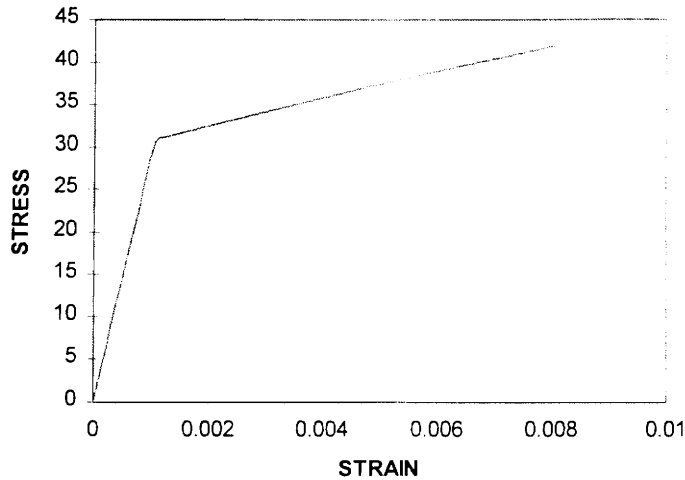

Figure 1.2-1
Idealized Stress-Strain Relationship

The second part of Fisher's study was to relate the knowledge obtained from the tension tests to load-deformation relationships of the bolted joints.

It was known that the deformation of the connection came from shearing, bending, and bearing of the fastener and the local deformations that occur on the connected plates. The basic equation reported by Wallaert and Fisher (1965) is:

$$R = \Delta K \quad (\text{Eq. 1.2-3})$$

in which K is the elastic stiffness of the connection, Δ is the bolt deformation, and R is the force applied. Although Fisher determined K from experimental data, Tate and Rosenfeld (1946) proposed the following:

$$K = \frac{2}{D_s + D_b + 2D_{br}} \quad (\text{Eq. 1.2-4})$$

in which $D_s = \text{deformation of shearing} = \frac{t + t'}{3G_b A_b}$

$$D_b = \text{deformation of bending} = \frac{t'^3 + 4tt'^2 + 4t't^2 + t^3}{192EI_b}$$

$$D_{br} = \text{deformation of bearing} = \frac{2(t + t')}{Ett'}$$

where E = modulus of elasticity, G_b = shear modulus, A_b = fastener area, I_b = moment of inertia, t, t' = thicknesses of the plates.

Fisher derived an analytical model based on his previous studies on perforated plates. This model satisfied the below conditions:

1. At zero load the deformation is zero;
2. For comparatively small deformations of the bolt, the load-deformation response has a constant slope;
3. As ultimate deformation is reached the bolt force increases at a decreasing rate;
4. Deformation of the bolt consists of shear, bending, bearing deformations of the bolt and bearing deformations of the plates.

The model is given by:

$$R = \tau [1 - e^{-\mu\Delta}]^\lambda \quad (\text{Eq. 1.2-5})$$

where R = bolt force; τ, μ , and λ = regression coefficients; Δ = deformation of the bolt.

From the regression study τ is found to be R_{ult} , then the equation becomes:

$$R = R_{ult} [1 - e^{-\mu\Delta}]^\lambda \quad (\text{Eq. 1.2-6})$$

The results of the regression study for the different tests are tabulated in Table 1.2-1.

The way in which the tests were conducted, either tension or compression, only affects R_{ult} of the connection. This factor seems to have little effect on the empirical

parameters. Fisher believed that the factor that affected those parameters is the physical and geometrical properties of the connecting plates and the bolts.

From the test data, it can be observed that bolts connecting higher strength steels has less deformation capacity.

Table 1.2-1 Summary Of Test Results (Fisher 1965)

Type of Bolt	Diameter (in.)	Connecting Material	Test Jig	R _{ult} (Kips)	Δ _{ult} (in.)	Empirical Par.	
						μ	λ
A325	7/8	A440	Tension	98.6	0.187	23	1.00
A325	7/8	A440	Compres.	102.3	0.200	23	1.00
A325	7/8	A440	Tension	92.5	0.200	25	0.95
A325	7/8	A440	Compres.	104.0	0.239	22	1.00
A325	7/8	A440	Tension	95.2	0.220	22	1.00
A325	7/8	A440	Compres.	103.0	0.236	22	1.00
A325	7/8	A7	Tension	98.5	0.238	18	1.00
A325	7/8	A7	Compres.	106.9	0.291	18	1.00
A325	7/8	A7	Tension	101.8	0.279	18	1.00
A325	7/8	A7	Compres.	102.5	0.300	18	1.00
A490	7/8	A440	Tension	124.4	0.202	23	0.40
A490	1	A514	Tension	151.7	0.155	28	0.35

1.2.2 Crawford and Kulak (1971)

With a group of fasteners, force is often assumed to act through the centroid of the connecting elements, but this situation may not be true for most of the connections that are designed. In actuality, there is always some eccentricity that causes rotation on the connectors. Crawford and Kulak (1971) reported on the behavior of fastener groups subjected to a combination of direct shear and moment, which results from such eccentricity.

The previous approach to this problem was based on the assumption that the load-deformation response of the fasteners is always elastic, so the yield point is never exceeded. However the tests have shown that the relationship between load and deformation goes far beyond the elastic part to the extreme yielding portion. Also, individual fasteners do not have a well-defined shear yield stress.

In the design of eccentrically loaded fasteners, the resistance of each fastener is assumed to be proportional to its distance from the centroid of the group of fasteners. The approach investigated by Crawford and Kulak replaces the actual eccentricity with an effective one to obtain a less conservative and more realistic load capacity on the connection. Therefore, a rational theoretical approach had to be proposed to determine the ultimate load carrying capacity of the connection and some design considerations and suggestions were to be made.

An analytical relationship was presented by Crawford and Kulak to predict the load-deformation response of individual fasteners. This relationship was derived from the experimental studies made earlier (Fisher 1965). It is expressed as:

$$R = R_{ult} (1 - e^{-\mu\Delta})^\lambda \quad (\text{Eq. 1.2-7})$$

where

R = fastener load at any given deformation.

R_{ult} = ultimate load capacity of fastener.

Δ = shearing, bending, and bearing deformations of fastener and local bearing deformation of the connecting plates.

μ, λ = regression coefficients.

e = base of natural logarithms.

The values of R_{ult} , μ , λ , were determined by conducting a series of six tests of single bolt, double shear tests. The R_{ult} , and Δ_{ult} values were taken directly from the test results. A trial and error curve-fitting procedure was used to determine the values of μ , λ .

Crawford and Kulak made the following assumptions for the theoretical approach:

1. The fastener group rotates around the instantaneous center of rotation.
2. The deformation of the fastener changes linearly with its distance from the center of rotation and acts perpendicularly to the rotation center.
3. The ultimate strength of the group of fasteners is reached when the ultimate strength of the fastener which is furthest to the center of rotation is reached.

The bolts were A325 high-strength bolts with 3/4-in. diameter and the plates were ASTM A36 steel which are 4 in. by 4 in. with 13/16-in. diameter drilled holes. The test specimens brought to a snug-tight position and the bolts were applied an additional 1/2 turn. The specimens were loaded in compression and deformation data was read from the dial gage placed on the head of the compression machine. As the load was increased, the deformations were plotted on a graph (Figure 1.2-2). All failures occurred by the shearing of the connecting bolt.

As for the analytical model, the test data was investigated with the method mentioned earlier to find the coefficients. The expression $R = R_{ult} (1 - e^{-\mu\Delta})^\lambda$ best fit the data when $\mu = 10.00$ and $\lambda = 0.55$. The maximum bolt force was found to be 74.0 kips with a maximum deformation of 0.34 in. None of the tests had a well-defined yield point.

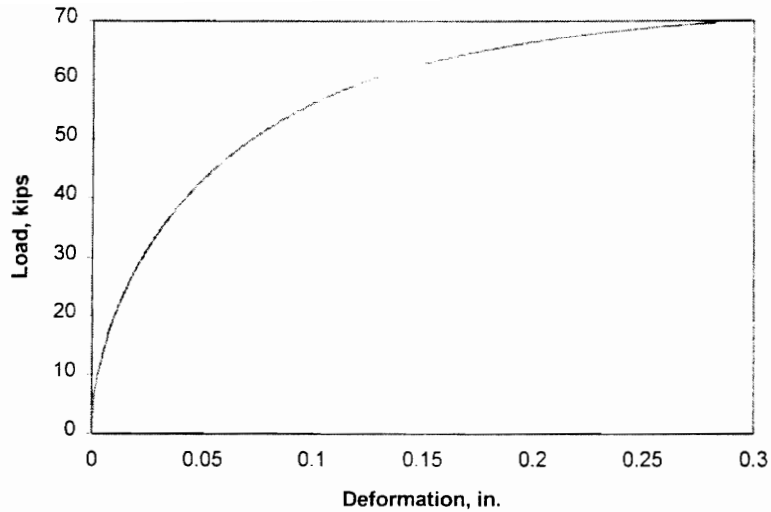

Figure 1.2-2
Load-Deformation Response Of Bolts

Crawford and Kulak conducted some full size connections tests in order to verify the knowledge gained from the single bolt test results. Some conclusions they derived from these tests were:

1. The analytical model developed was for single bolts, but the test specimens consisted of identical connections. Ideally, both connections would fail at the same time; however, due to the discrepancies of the materials the ultimate point is reached when one connection is failed and obviously this was not twice the load that has been calculated.
2. The furthest connection bolt did not reach the maximum value that the single bolt tests indicated.

The research concluded with a theoretical method for the load-deformation response of the eccentrically loaded fasteners and the actual size tests verified the ultimate load predictions using the theoretical approach.

1.2.3 Richard, Gillett, Kriegh and Lewis (1980)

A series of 126 single bolt, single shear load- deformation tests were made at the University of Arizona in Tucson. The study included the analysis and design of the single plate framing connections. The design procedure of the single plate connections assumes that each bolt carries an equal load that is generated from the total shear load when the beam is loaded. The shear load is calculated due to the assumption of simple support which is relatively free to rotate. This procedure hasn't been proven thoroughly since there are not many investigations on this subject. This study reflects the actual structural behavior of the simply supported connections, as well as the actual load and stress distribution.

The single plate framing connections obtain their ductility from: (1) bolt deformation in shear, (2) bolt hole distortion, and, (3) out-of-plane bending of the plate. Supplementary ductility may be obtained from the slippage.

To understand the actual behavior of the connections, a series of single bolt, single shear tests was conducted with different bolt diameters and various plate thicknesses. A total of 126 tests were performed to determine the load-deformation response of the connection. The limitations of the experimental study were:

1. ASTM A325 and ASTM A490 bolts were used.
2. Bolt diameters were 3/4-in., 7/8-in., and 1-in.
3. Plate materials were ASTM A36 and ASTM A575 Grade 50.

4. Plate thicknesses were changed from 1/16-in. by 1/4-in. plates to 5/8-in. plates.
5. Edge distances were 1.25 and 1.5 in. for 3/4-in. diameter bolts, 1.5 and 1.75 in. for 7/8-in. diameter bolts, and 1.75 in. and 2 in. for 1-in. diameter bolts.
6. Edges of the plates were sheared.
7. Bolt holes were punched (1/16-in. oversize).

The test specimens were either 8 in. or 10 in. long, and 4 in. wide. The bolt hole was punched on the centerline of the plate.

The test specimens were aligned in the test fixture and the bolts that connected the plates were hand tightened. A load of 5000 lbs was exerted on the specimen to maintain a bearing in order to eliminate all slip from the connection. The bolt was then prestressed with the turn-of-the-nut method while the preload was maintained. The preload was removed and the dial gages were mounted. A load was applied at a slow rate and deformation data was recorded at reasonable intervals.

Sequential results of the tests were obtained by averaging the dial gage readings and subtracting the elastic response of the plates. They were overlaid with the curve obtained from Richard's formula.

$$R = \frac{K_1 \Delta}{\left[1 + \left| \frac{K_1 \Delta}{R_0} \right|^n \right]^{1/n}} + K_p \Delta \quad (\text{Eq. 1.2-8})$$

where

R= bolt load, kips

Δ= bolt-plate deformation, in.

R_0 = bolt reference load, kips

n = bolt load-deformation curve shape parameter

K_p = slope of the load-deformation curve in the extreme yielding range

$K_1 = K - K_p$, where K is the initial slope of the load-deformation curve

$$K = 2E \frac{t_1 t_2}{t_1 + t_2} \quad (\text{Eq. 1.2-9})$$

where

E = modulus of elasticity (29,000 ksi for steel)

t_1, t_2 = plate thicknesses, in.

This stiffness equation was developed by Vought (1975) for single fastener lap joint stiffnesses. Table 1.2-2 tabulates the curve parameters obtained from this research project.

The curves obtained from the tests are observed for their similarity to the other tests. When the curves do not vary much, one can come to the conclusion that the strength and the ductility of the connection will depend on the characteristics of the thinner plate.

Also important to mention are three modes of failure related to the single bolt, single shear tests. Those are:

1. Shear failure of the bolt. This is the most critical case that the connection has no capacity of carrying load.
2. Bearing failure of the plates in which yielding of the plates occurs behind bolt. This is not a critical mode of failure. The connection has still carrying capacity.

Table 1.2-2 Curve Parameters of Richard's Tests

Bolt	Plates	K	K_p	R_o	n
3/4-in. A325	1/4-1/4 (A36)	7250	10	20	1.0
	5/16-5/16 (A36)	9063	-10	50	0.4
	3/8-3/8 (A36)	10875	0	40	0.5
	7/16-7/16 (A36)	12700	10	40	0.5
	1/2-1/2 (A36)	14500	20	30	0.7
	1/4-3/8 (A36)	8700	-30	30	0.6
	1/4-1/2 (A36)	9667	-30	30	0.6
	3/8-1/2 (A36)	12400	0	40	0.5
	3/8-3/8(Gr. 50)	10875	20	30	0.7
7/8-in. A325	5/16-5/16 (A36)	9063	9	30	0.7
	3/8-3/8 (A36)	10875	20	40	0.5
	7/16-7/16 (A36)	12700	0	50	0.5
	1/2-1/2 (A36)	14500	10	40	0.7
	1/4-3/8 (A36)	8700	20	30	0.8
	1/4-1/2 (A36)	9667	20	30	1.1
	3/8-1/2 (A36)	12400	10	40	0.6
	3/8-3/8 (Gr. 50)	10875	10	40	0.6
1-in. A325	1/2-1/2 (A36)	14500	20	20	0.5
	5/8-5/8 (A36)	18125	0	90	0.4
3/4-in. A490	1/2-1/2 (A36)	14500	-10	70	0.4
	3/8-3/8 (A36)	10875	0	40	0.6
	7/16-7/16 (A36)	12688	0	60	0.4
	5/8-5/8 (A36)	18125	10	60	0.4
7/8-in. A490	1/2-1/2 (A36)	14500	40	40	0.7
	5/8-5/8 (A36)	18125	40	50	0.5
	7/16-7/16 (A36)	12688	0	60	0.5
	1/2-1/2 (Gr. 50)	14500	40	50	0.6
	5/8-5/8 (A36)	18125	30	50	0.7
1-in. A490	1/2-1/2 (A36)	14500	40	40	0.5
	5/8-5/8 (A36)	18125	20	70	0.5

3. Transverse tension tearing of the plate. This failure results in “strain softening” since the connection can carry some load.

From the results of the single bolt tests, Richard reported the following results and recommendations in order to get a bearing kind of failure:

1. The D/t ratios given in Table 1.2-3 or Table 1.2-4 can be used for A36 beams and plates; or alternatively

$$\frac{d}{t} = 2 \frac{F_y}{36} \quad \text{for } F_y \geq 36 \text{ ksi} \quad (\text{Eq. 1.2-10})$$

2. An e/D ratio of 2.0 should be provided. A deformation of 0.30 in. was used as the criterion of ductility.

Table 1.2-3. D/t Ratios

Bolt Size, in.	Web or Plate Thickness in Inches								
	1/4	5/16	3/8	7/16	1/2	9/16	5/8	11/16	3/4
3/4	3.0	2.4	2.0	1.7	1.5	1.33	1.2	1.09	1.0
7/8	3.5	2.8	2.33	2.0	1.75	1.56	1.4	1.27	1.17
1	4.0	3.2	2.67	2.2	2.0	1.78	1.6	1.45	1.33

|----- Limits A325's ----->

|----- Limits A490's ----->

Table 1.2-4, Maximum Web or Plate Thicknesses

Bolt Size, in.	A325	A490
3/4	3/8	1/2
7/8	7/16	5/8
1	9/16	11/16

1.3 CURRENT DESIGN PROCEDURE

The study conducted at Virginia Polytechnic Institute and State University investigates the actual behavior of bolted connections. The purpose of this study is to establish better ways of predicting load-deformation relationships taking into account different properties of the materials and their geometries. Although these kinds of connections have been in use for many years, it is a common belief and concern that design is not based on the actual behavior of the bolted connections. This section deals with current design practice.

Failure mode is an important concern in the design process of a structure, because if we can predict the kind of the failure and the point at which the designed object is likely to fail, we just design the object for that mode and that force with the exact amount of material. The current design practice predicts the failure mode well, but on the other hand it has been proven to be insufficient in displaying the actual load-deformation behavior of bolted connections. The main goals of this study are to verify the applicability of the available strength models and to understand the load-deformation response of the connection for generalization purposes.

In a bolted connection it is possible to see a large variety of failure modes. Those may be:

1. Shear failure of bolt, (Fig. 1.3-1).
2. Shear failure of plate, (Fig. 1.3-2).
3. Bearing failure of bolt, (Fig. 1.3-3).

4. Bearing failure of plate. (Fig. 1.3-4).
5. Bending failure of bolt. (Fig. 1.3-5).
6. Transverse tension failure of the plate. (Fig. 1.3-6).
7. Tension failure of the bolt, (Fig. 1.3-7).
8. Splitting failure of the plate. (Figure 1.3-8).

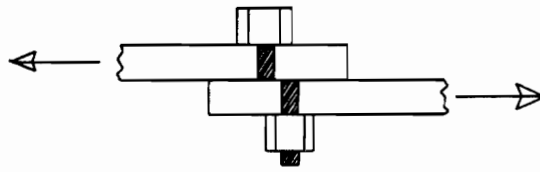

Figure 1.3-1

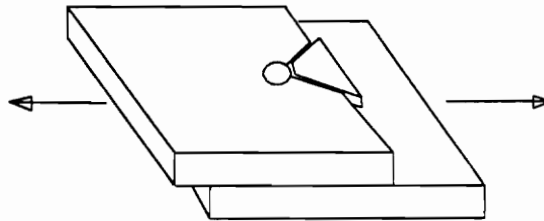

Figure 1.3-2

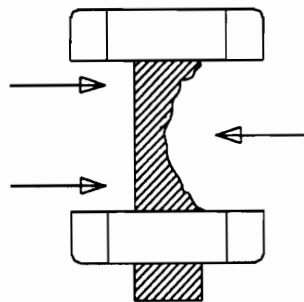

Figure 1.3-3

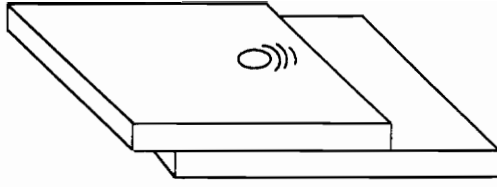

Figure 1.3-4

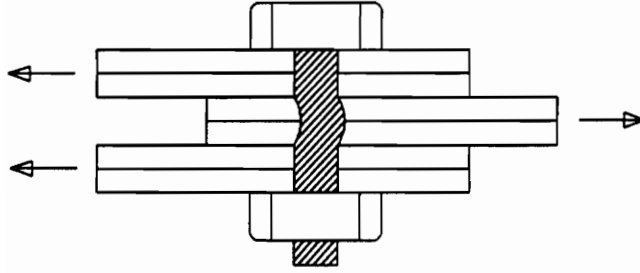

Figure 1.3-5

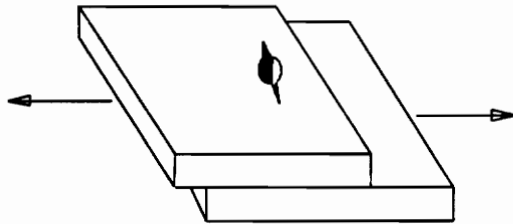

Figure 1.3-6

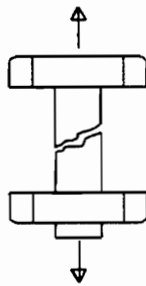

Figure 1.3-7

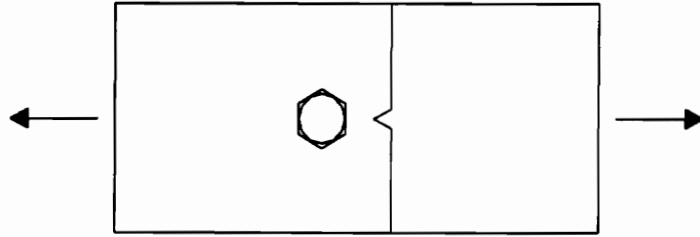

Fig. 1.3-8

The failure modes that are seen most are shear failure of plate (bearing/tear-out), shear failure of bolt, and splitting failure of the plate. These are the most possible strength limit states that may control the strength of a bolted connection.

In this study shearing of bolt, bearing/tear-out, and splitting of plate failures were mostly seen. These limit states will be investigated in the following section.

1.3.1 Major Failure Modes in Bolted Connections

1.3.1.1 Shearing Failure of Plate

The bearing strength of a material is related to its deformation capacity; the more it deforms, the higher its bearing strength. On the other hand, there is a limit to which the connection is allowed to deform. Beyond that point the connection is said to have lost its capacity to carry load. As seen in Fig. 1.3.-1, the bearing occurs where the connected plate and the bolt interact. It can be easily understood that shearing failure of the plate is associated closely with this failure.

The bearing strength R_n is the force applied on the bolt to tear or split the plate. If L_e increases, the bearing strength increases. Therefore, as L_e increases it is less likely to have a tear out kind of failure. In Fig. 1.3-9 a failure scheme is presented. Although the shear plane has some angle to the axis of loading, α has to be taken as 0° as a lower bound for strength.

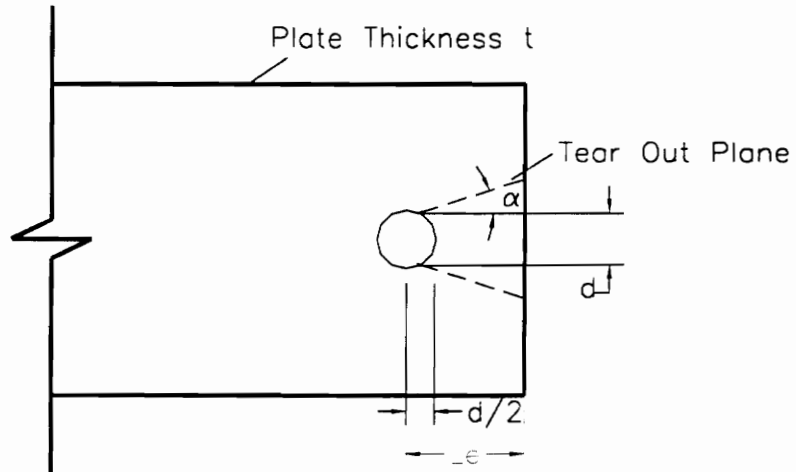

Figure 1.3-9
Bearing Strength Related To Edge Distance

The equation for shear strength is derived as:

$$R_n = \tau_u^p A_n \quad (\text{Eq. 1.3-1})$$

where $A_n = 2t \left[L_e - \frac{d}{2} \right]$

$$\tau_u^p = \text{Shear strength of the plate} = 0.70F_u$$

d = bolt diameter,

L_e = edge distance,

t = thickness of the thinner plate.

Thus,

$$R_n = 2t \left[L_e - \frac{d}{2} \right] (0.70F_u) \quad (\text{Eq. 1.3-2})$$

$$R_n = 1.40F_u dt \left[\frac{L_e}{d} - \frac{1}{2} \right] \quad (\text{Eq. 1.3-3})$$

If the minimum edge distance is taken as $L_e = 1.5d$, the equation becomes:

$$R_n = 1.40F_u dt \quad (\text{Eq. 1.3-4})$$

It is required that the center-to-center spacing of bolts [LRFD J3-3]:

$$L \geq 2 \frac{2}{3} d = 2.67d$$

The value of R_n is given by

$$R_n = 3.0F_u dt \quad [\text{LRFD-J3.10; ASD-J3.8}]$$

which is the basic expression to prevent tear out failure. However, deformation around the bolt may be excessive. Therefore, this expression should be used in cases in which local deformation is not an important issue in the design.

In order not to have the bolt hole elongate more than 0.25 in. LRFD recommends using :

for standard and short slotted holes:

$$R_n = 2.4F_u dt \quad [\text{LRFD J3.10a}]$$

for long slotted holes;

$$R_n = 2.0F_u dt \quad [\text{LRFD J3.10b}]$$

Design Recommendations for Bearing/Tear Out Failure

Kulak and Fisher (1987) made some further recommendations for the design of bolted connections for shearing failure of plate:

1. Design Load x Load Factor $\leq \phi F$; alternatively $\frac{L}{d} \geq 1.7 \sigma_b / \sigma_u^p$;
2. $\frac{L}{d} \geq 1.5$;
3. $\sigma_b / \sigma_u^p \leq 3.0$

where σ_b = tension strength of bolt;

σ_u^p = tension strength of plate.

1.3.1.2 Shearing Failure of Bolt

Another kind of failure mode in bolted connections which is often reported is shearing failure of bolt. This failure is not desired because the connection loses its load carrying capacity totally (Fig. 1.3-2).

The nominal strength, R_n , for a bolt in shear will be the ultimate shear strength across the gross area of the bolt times the number of shear planes.

$$R_n = mA_b\tau_u \quad (\text{Eq. 1.3-5})$$

where m = number of the shear planes;

A_b = gross area of the bolt;

τ_u = ultimate shear strength of the bolt.

As a result of the experiments, there is a linear ratio between the tensile strength and the shear strength of the bolts. Ultimate shear strength of the bolt is 62% (Ref: Kulak et al. (1987) "Guide to Design Criteria for Bolted and Riveted Joints") of its ultimate tension strength.

$$\tau_u = 0.62F_u \quad (\text{Eq. 1.3-6})$$

Therefore,

$$R_n = mA_b(0.62F_u) \quad (\text{Eq. 1.3-7})$$

These equations are valid when the shear plane is on the non-threaded part of the bolt. This is designated by X, meaning excluded, after bolt type (e.g. A325-X). Sometimes the shear plane can coincide with the threaded part of the bolt where the gross area is smaller. Then A_b of the bolt has to be adjusted for this situation. This is designated by N after the bolt type (e.g. A325-N)

$$A_b^N = 0.70A_b^X \quad (\text{Eq. 1.3-8})$$

Thus,

$$R_n = m(0.7A_b)(0.62F_u) \quad (\text{Eq. 1.3-9})$$

$$R_n = 0.43mF_uA_b \quad (\text{Eq. 1.3-10})$$

However, LRFD uses more conservative equations for the shear design of bolts. LRFD 1st Edition tabulates design strength of fasteners in Table J3.2. These values are derived from the following equations:

when threads are excluded from the shear planes.

$$R_n = 0.60mF_uA_b \quad [\text{LRFD C-J3.3}]$$

when threads are not excluded from the shear planes.

$$R_n = 0.45mF_uA_b \quad [\text{LRFD C-J3.3}]$$

In the second edition of LRFD, the parameters, 0.6 and 0.45, are replaced with 0.5 and 0.4, respectively [LRFD 2nd Edition C-J3.6].

1.4 SCOPE OF RESEARCH

The main goals of this research are:

1. To review and verify AISC provisions on the load-deformation behavior of bolted connections and verify the applicability of the other research;
2. To develop a general physical model that allows us to determine the actual load-deformation response of the bolted connections. This model will be based on geometry and material properties;
3. To evaluate the possible failure modes and detail the connection to prevent it from a particular kind of failure.

A series of 70 single bolt, single shear tension tests were conducted at the Structures and Materials Laboratory at Virginia Polytechnic Institute and State University. The results of these tests will be compared with previously conducted research on bolted connections. A review of existing load vs. deformation expressions is conducted and their applicability to the tests is presented. An additional expression for the load vs. deformation response was developed as a part of this study and is reported.

CHAPTER 2

EXPERIMENTAL INVESTIGATION

2.1 GENERAL

Experimental investigation is one of the most important parts of research by means of understanding the behavior of the investigated subject. In order to have this basic comprehension, a series of 70 tests was conducted in the Structures and Materials Laboratory of Virginia Polytechnic Institute and State University. These tests consisted of single bolt, single shear tension tests. Different combinations of plate thicknesses and bolt sizes were tested to provide a background on the interaction between these variables.

2.2 TEST SPECIMENS

2.2.1 Plates

The plates used in the tests were nominally A36 steel. The reason for this is the common use of this grade of steel in connection design. Although Grade 50 steel is gaining popularity in current steel design practice, the investigation only considered A36 plates. It is also common knowledge that current A36 steel has material properties in the

same range as the Grade 50 steel. However, to expand the coverage of the study, Grade 50 steel can be used with A36 steel in order to determine the differences in the behavior of the connection.

The plates used in the tests were 24 in. long and the width of the plates varied from 4 in. to 6 in. The plate thicknesses included 1/8-in., 1/4-in., 3/8-in., 1/2-in., 5/8-in., 3/4-in., and 1 in. A general view of the specimen is shown in Figure 2.2-1.

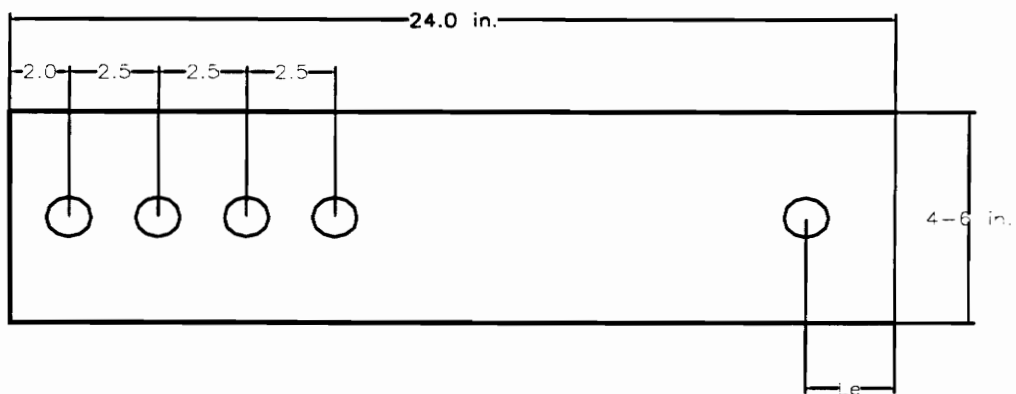

Figure 2.2-1
Test Specimen

The group of four bolt holes on one end of the specimen were used to attach the specimen to the test apparatus. They were designed to withstand the maximum bolt force that could develop during the testing so that an unexpected failure would not occur at that location. The other end of the plate has the bolt hole with certain edge distances provided. This distance is another important variable of the tests. The edge distance, which is the length measured from the end of the plate to the center of the bolt hole, is taken as two times the bolt diameter. This was recommended by the AISC in the current

design specifications. The edge distance is reduced to $1.5d_b$ in order to investigate its effect on the load-deformation response of a bolted connection.

A bolt hole was drilled with the specified edge distance on the center line of the specimen. It was oversized by 1/16-in. to account for inconsistencies that might occur in the fabrication.

Two coupons were taken from the plates and tested in tension to determine their material properties. The yield strengths were found to be in the range of 44 to 52 ksi, and the ultimate strengths were found to be in the range of 68 to 74 ksi. The elastic modulus was found to be approximately 29000 ksi.

2.2.2 Bolts

All specimens were fabricated with ASTM A325 bolts. The diameter of the bolts tested were 3/4-in., 7/8-in., and 1-in. Only one bolt type was used in a given test. All bolts were arranged such that the threads were excluded from the shear plane. The shear strength of the A325 bolts was taken as 72 ksi which is 62% of its tension strength as recommended in the specification.

2.3 INSTRUMENTATION

The main goal of this experimental study was to determine the load-deformation response of a single plate, single bolt connection in tension. with an analytical model

being subsequently developed. To accomplish these goals, the tests had to include instrumentation to measure the deformation around the connection when tension was exerted on it. For this purpose, two pairs of potentiometers per connection were used.

Two connections at a time were tested. The elongation of the whole plate had to be excluded; thus, the potentiometers were located half an inch under the lap on each side of the plate. Figure 2.3-1 shows the instrumentation details. This application was used in each of the tests. A PC-based data acquisition system was used to collect and record data.

The specimens were white-washed with lime to determine the general location of yielding and high stress concentration. This works efficiently because the whitewash flaking can be seen when the yielding starts.

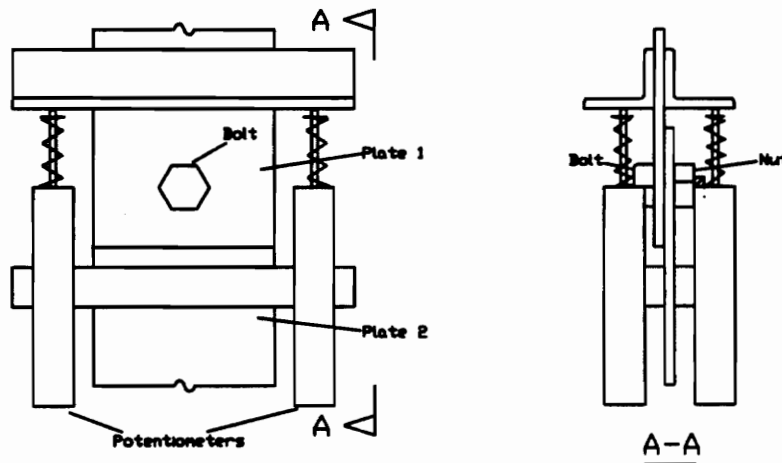

Figure 2.3-1
General Instrumentation

2.4 TEST SETUP AND TESTING PROCEDURE

2.4 TEST SETUP AND TESTING PROCEDURE

The plates were fastened with the specified bolts and white-washed one night before the testing. The bolts were hand-tightened at that time. A universal testing machine was used to apply load to the connections. The first stage of the setup included attaching the hangers to the top and lower jaws of the testing machine. Then the two combination of the plates were bolted on those tightly so that no slip between the rigs and the test specimens would occur when they were subjected to tension.

Before putting on the instrumentation, the specimens were tensioned to a load of 5000 lbs each in order to avoid the slippage as the bolt and the plate are not in bearing position. This load was increased up to 15000 lbs due to the total thickness of the connection. After the bolts were brought to a bearing position they were given an additional 1/3 turn with the turn of the nut method. This pretensioning process provided additional stiffness on the connection. Figure 2.4-2 shows the general view of test setup.

Figure 2.4-3 shows the case in which the connections were not pretensioned to a certain degree. This pretensioning prevented the major slip that occurs at some load. The slip was taken with tensioning before it took place. This phenomenon is known as “The Banging Syndrome of the Connections,” because the energy created by pretensioning is released in the form of sound when the connection slips.

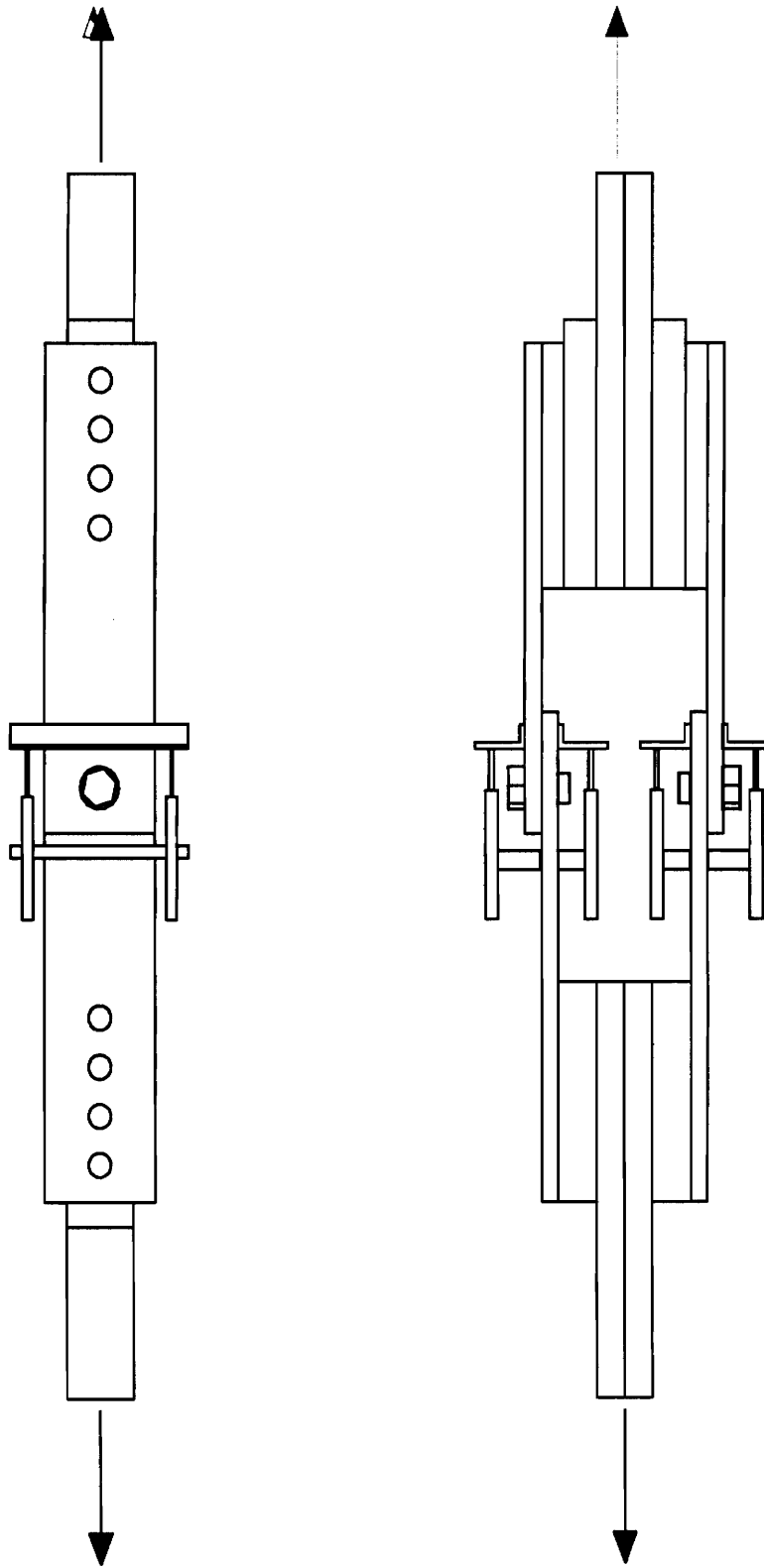

Figure 2.4-2
General View of Test Setup

The instrumentation was attached to the plates and the load was brought to zero level to start out the testing.

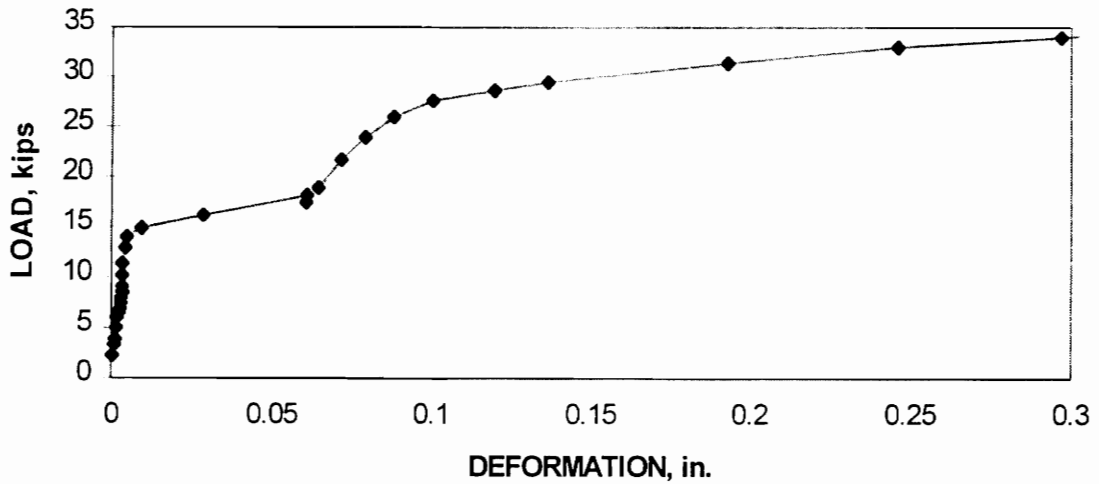

Figure 2.4-3
Behavior Of A Bolted Connection
With Slippage

The load was applied increasingly and deformation data was recorded incrementally. The loading rate was predetermined and input to the computer program so that at different stages of testing different loads rates were applied on the connections. Also the specimens were observed during the course of testing for visual changes like yielding and stretching of the bolt hole. These observations, as well as deformations and corresponding loads were written down on data sheets.

The data collection lasted until one of the connections failed.

2.5 TEST MATRIX

Two stages of testing were performed. The first stage covered preliminary testing to gain some insight to the problem. Due to the results of these test, a final test matrix was created. Tables 2.5-1 and 2.5-2 show the preliminary and final test matrices respectively.

Table 2.5-1 Preliminary Test Matrix

Plate 1	Plate 2	Bolt Diameter	Le/d
1/4	1/4	3/4	2
1/4	3/8	3/4	2
1/4	1/2	3/4	2
1/4	5/8	3/4	2
1/4	3/4	3/4	2
3/8	3/8	3/4	2
3/8	1/2	3/4	2
3/8	3/4	3/4	2

Table 2.5-2 Test Matrix

Plate 1	Plate 2	Bolt Diameter	Le/d
1/8	1/8	0.75	2
1/8	1/4	0.75	2
1/8	3/8	0.75	2
1/8	1/2	0.75	2
1/8	5/8	0.75	2
1/4	1	0.75	2
1/4	3/8	0.75	2
3/8	1	0.75	2
1/2	1/2	0.75	2
1/2	5/8	0.75	2
1/2	1	0.75	2
5/8	5/8	0.75	2
5/8	1	0.75	2
1	1	0.75	2
1/8	1/8	0.875	2
1/8	1/4	0.875	2
1/8	3/8	0.875	2
1/8	1/2	0.875	2
1/8	3/4	0.875	2
1/8	1	0.875	2
1/2	1/2	0.875	2
1/2	3/8	0.875	2
1/2	1/2	0.875	2
1/2	3/4	0.875	2
1/2	1	0.875	2
3/8	3/8	0.875	2
3/8	1/2	0.875	2
3/8	3/4	0.875	2
3/8	1	0.875	2
1/2	1/2	0.875	2
1/2	3/4	0.875	2
1/2	1	0.875	2
3/4	3/4	0.875	2
3/4	1	0.875	2
1	1	0.875	2
1/4	1/4	1	2
1/4	3/8	1	2
1/4	1/2	1	2
1/4	5/8	1	2

Table 2.5-2 Test Matrix (Continued)

Plate 1	Plate 2	Bolt Diameter	Le/d
1/4	3/4	1	2
1/4	1	1	2
3/8	3/8	1	2
3/8	1/2	1	2
3/8	5/8	1	2
3/8	3/4	1	2
3/8	1	1	2
1/2	1/2	1	2
1/2	5/8	1	2
1/2	3/4	1	2
1/2	1	1	2
5/8	5/8	1	2
5/8	3/4	1	2
5/8	1	1	2
3/4	3/4	1	2
3/4	1	1	2
1	1	1	2
1/8	1/8	0.75	1.5
1/4	1/4	0.75	1.5
3/8	3/8	0.75	1.5
1/2	1/4	0.75	1.5
1/2	1/2	0.75	1.5
5/8	1/4	0.75	1.5
5/8	5/8	0.75	1.5
3/4	1/4	0.75	1.5
3/4	3/4	0.75	1.5
1/4	1/4	0.875	1.5
5/8	1/4	0.875	1.5
5/8	5/8	0.875	1.5
3/4	3/4	0.875	1.5
1/4	1/4	1	1.5
5/8	1/4	1	1.5

CHAPTER 3

TEST RESULTS

3.1 GENERAL

Results of the tests are discussed in this chapter. Individual summaries of the tests are included in Appendix C. Detailed information on the tests, as well as load-deformation graphs that include comparisons to equations developed in previous research, are given in the summaries. The material properties of the tests are detailed in Appendix B. The results are organized according to plate thickness and subdivided based on bolt diameter.

3.2 1/8-in. PLATE COMBINATIONS

The 1/8-in. combinations were tested with only 3/4-in. and 7/8-in. diameter bolts because of their thin nature. These tests behaved like light gauge cold form steel, bending excessively in front of the bolt and on the corners. Most of the time failure mode was this bending rather than bearing/tear out.

3.2.1 3/4-in. Diameter Bolts

This group of the tests had the thinnest of all plates used in this testing program. The linearity was maintained up to a certain point (Figure 3.2-1). The thickness of the connection affected the length of this line. The thinnest connection, 1/8x1/8, had an upper load limit of 16 kips. The 1/8x1/4 and 1/8x3/8 combinations had an upper load limit of 16 kips. The 1/8x1/2 combination went up to 18 kips. However, the 1/8x5/8 combination had a value of 14 kips which is a significant drop in strength. This top point was determined by the yielding of the thinner plate.

When the rounded part of the curve was reached, the 1/8-in. combinations behaved differently from the 1/4-in. combinations in that they had undistinctive curvatures. This could be reasoned by looking at the plastic part of the load-deformation curve. It was observed that 1/8-in. thick plates started losing strength right after the curved portion. The 1/8x1/8 combination had almost a flat plastic slope. The other combinations exhibited decreases in strength in this region. The slope of the plastic portion decreased with the increasing thickness of the connection (Figure 3.2-1). The thinner connection, 1/8x1/8, failed at a higher load of 14 kips, with an ultimate deformation of 1.2 in. The others failed at 13 kips with deformations around 0.6 in.

The failure modes in the 1/8-in. combinations occurred with splitting in the bulged part in front of the bolts. The reason for this was the shear-cut of the plates. This method creates a sharp edge at the end of the plate so that it acts as a field of high-stress concentration. The splitting starts from that point on and leads to the failure mechanism.

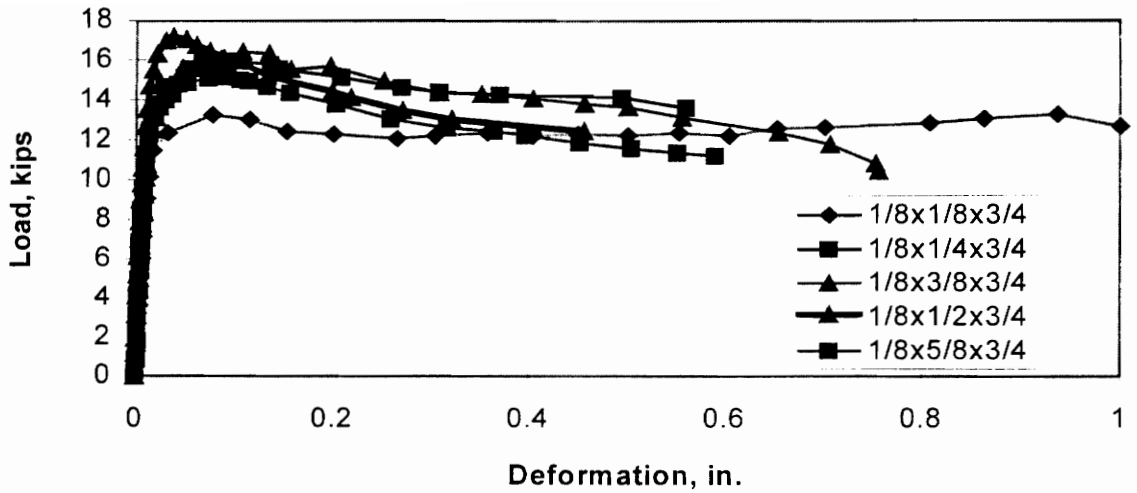

Figure 3.2-1
Data Overlay of 1/8-in. Combinations with 3/4-in. Bolts

3.2.2 7/8-in. Diameter Bolts

The 1/8-in. combinations with 7/8-in. diameter bolts behaved like 3/4-in. bolts, however, the yielding point was slightly higher with the enlarged bolt diameter. The linear part of the curve was maintained until the yielding of the thinner plate. The peak point was 16 kips for 1/8x1/4, 18 kips for 1/8x3/8, and 19 kips for 1/8x1/2 combinations. However, the 1/8x5/8 combination had a decrease to 17 kips (Figure 3.2-2).

The curved portions had a larger radius as compared to the 3/4-in. bolt diameter tests. Similarly, the strength of the thinner plate in the combination was lost and load capacity decreased with the increasing deformation of the connection. This time, the connections had the same plastic slopes. The connections failed around 0.8 in. of deformation at a load value of approximately 13 kips (Figure 3.2-2).

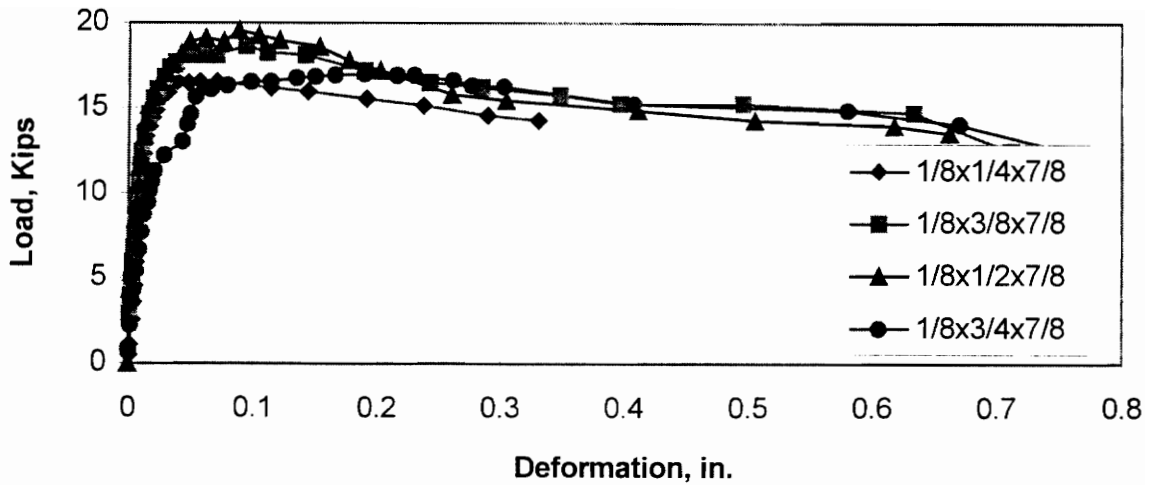

Figure 3.2-2
Data Overlay of 1/8-in. Combinations with 7/8-in. Bolts

3.3 1/4-in. PLATE COMBINATIONS

3.3.1 3/4-in. Diameter Bolts

The results of the 1/4-in. combination tests show the expected behavior of a bolted connection. The load-deformation curve was linear up to a certain point. This point was observed to be very close to the yielding of the thinner plate. The initial stiffness increased with the increasing thickness of the connection. This was expected because the deformation should have been less with thicker combinations as more load is needed to deform the plates.

After the point at which the curve kept its linearity, deformations got excessive so that the curve rounded. This occurs because of the yielding of the plate. On the other hand, as the thickness of the connection increased, the rounded part of the curve had a higher load point which means the strength of the connection increased some. The load was 22 kips at that point. This increase in strength was around 10%.

The third part of the test data was related to the plastic portion of the load-deformation curve. This part was also linear with a slope that was less than the initial slope. The data indicated that the connection had an increasing strength as the deformation increased. The 1/4x3/4 combination almost had a flat plastic slope. The 1/4x1 combination had a negative slope, which means it lost its load carrying capacity after some point. In other tests, it has been observed that the specimens lost strength when they came close to failure.

All the plate combinations failed in bearing/tear out. All the combinations except for 1/4x1 had an increasing strength until failure. The ultimate strength of these combinations was around 25 kips. The maximum deformations varied with the varying thickness of the connections. As expected, the 1/4x1/4 combination had the highest deformation value at 1.2 in. The decreasing trend of deformations continued until 1/4x5/8. After that, the maximum deformations got fixed at a value of 0.25 in.

3.3.2 7/8-in. Diameter Bolts

The 1/4-in. combinations with 7/8-in. bolts displayed the same kind of behavior with 3/4-in. bolt combinations. The initial stiffness of the connection increased with its

increasing thickness. The linearity of the load-deformation curve was maintained up to a certain point. This point was also determined by the yielding of the thinner plate. Figure 3.3-1 shows the increasing initial stiffness due to connection thickness. It has been observed that linearity lasted longer as the thickness of the connection was increased. Also, the curve had a larger radius with thicker connections.

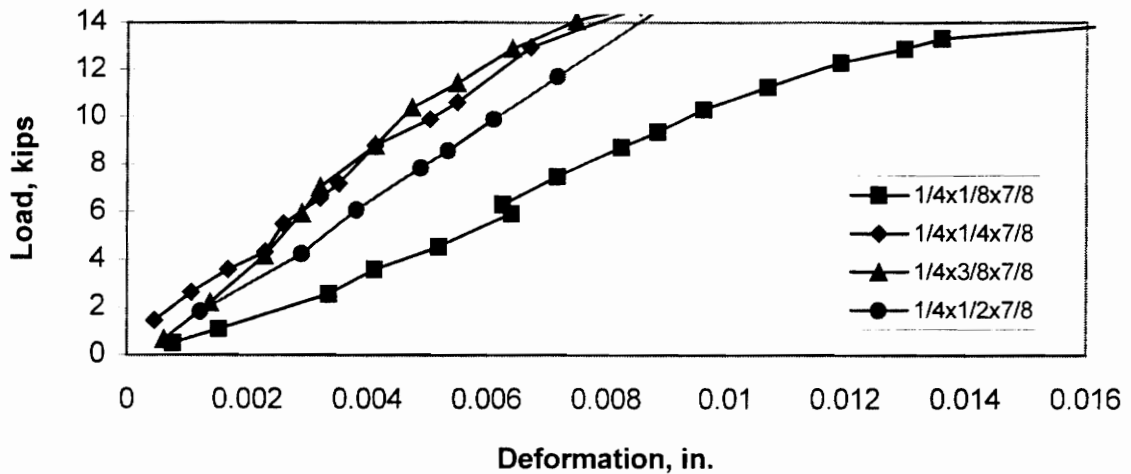

Figure 3.3-1
Initial Stiffness Of 1/4-In. Combinations With 7/8-In Bolts

The plastic portion of the combinations behaved as the 1/4-in. specimen with 3/4-in. bolts. The 1/4x1/8 group had a negative slope meaning that strength was lost right after hitting the plastic portion. The slope increased with 1/4x1/4, and became positive but it flattened as the thickness of the connection increased. The 1/4x1/2 combination had a negative slope.

The ultimate load carrying capacity was around 27 kips for each of the combinations except for 1/4x1/8 which had 16 kips. This can be explained as the thinner

of the connected plates is effective on the ultimate load carrying capacity. The thicker plate just changes the outline of the curve. It has been observed that the curves tend to end up at almost the same loads (Figure 3.3-2).

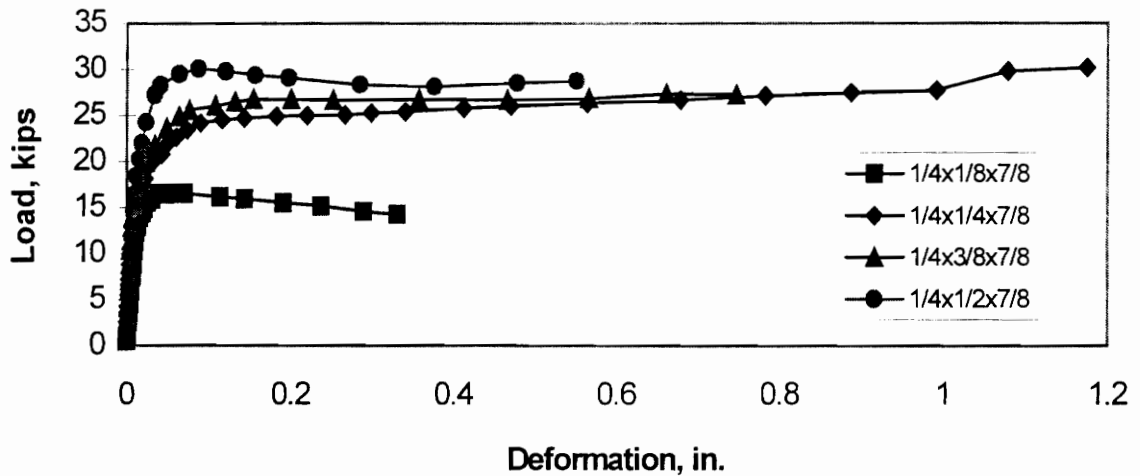

Figure 3.3-2
Data Overlay Of 1/4-In. Combinations With 7/8-In Bolts

3.3.3 1-in. Diameter Bolts

In this group of tests, the initial stiffness of the tests were almost the same with each other although the ductility changed due to the thickness of the connection (Figure 3.3-3).

The thinnest connection, 1/4x1/4, gained strength up to a load value of 17 kips. After this point, the connection had large deformations that were caused by yielding of the 1/4-in. plate. The other combinations showed almost the same behavior in this region

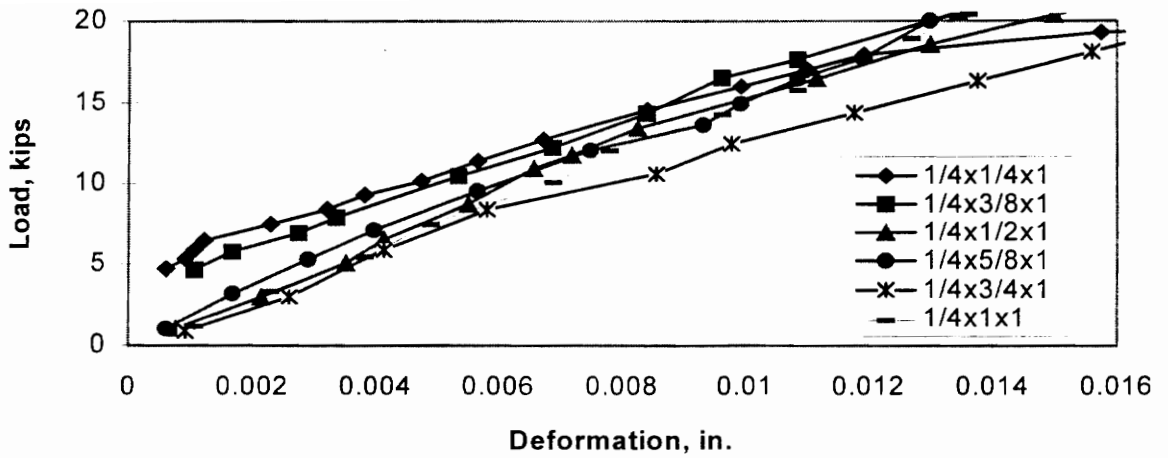

Figure 3.3-3
Initial Stiffness Of 1/4-In. Combinations With 1-In. Bolts

of the load-deformation curve. As seen in Figure 3.3-4, the curves grouped around the same load values which is around 34 kips. All of the connections failed with either tear out or splitting of the 1/4-in. plate. On the other hand, a little increase in the strength could be observed with the increasing connection thickness. After the yielding, the curves had flat slopes indicating that they maintained their strength until the failure. However, the 1/4x1/4 connection had a positive slope so that it gained some strength. It failed with bearing and tear out at 37 kips, deforming 1.6 in. The remaining combinations failed around 35 kips with deformations ranging from 0.6 in. to 0.85 in. (Figure 3.3-4). Failure modes were either tear out or splitting of the bulged part.

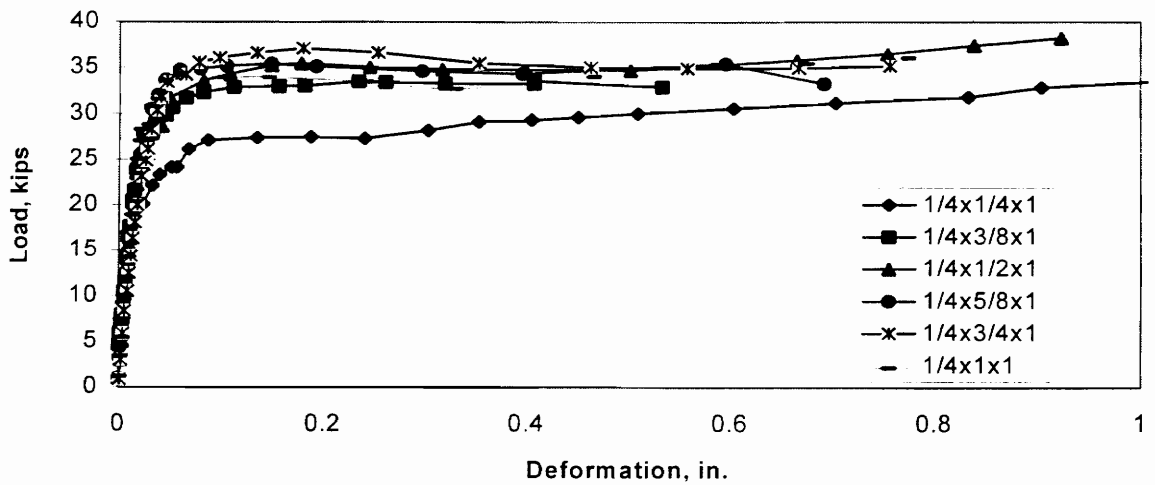

Figure 3.3-4
Data Overlay Of 1/4-In. Combinations With 1-In Bolts

3.4 3/8-IN. COMBINATIONS

3.4.4 3/4-in Diameter Bolt

In the 3/8-in. combinations with 3/4-in bolts, the initial stiffness increased with increasing thickness. However, the stiffness of the 3/8x1x3/4 combination was less than that for the 3/8x3/4x3/4 combination. The thickness of the connection affected the yielding point of the curve as illustrated in Figure 3.4-1.

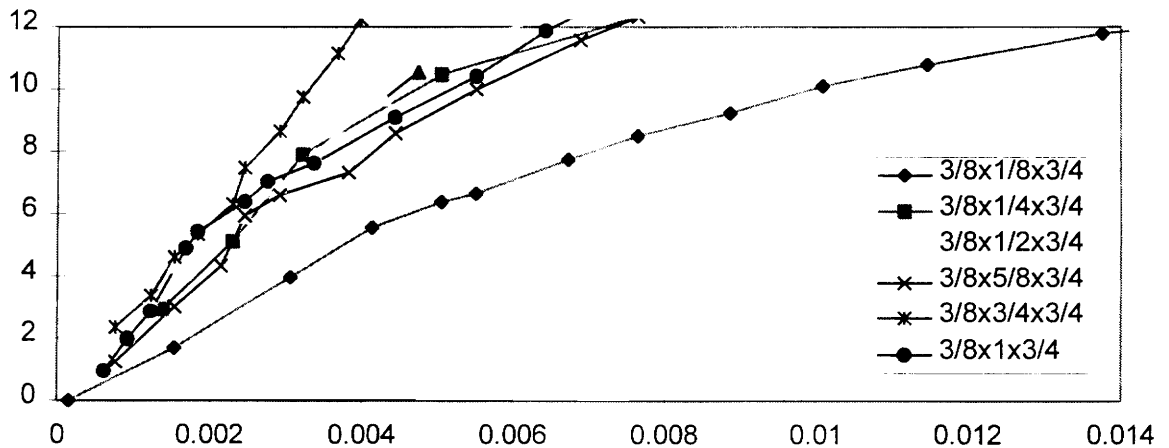

Figure 3.4-1
Initial Stiffness Comparison Of 3/8-In. Combinations With 3/4-In. Bolts

The thinner of the connected plates determined the load where the curve rounded. The 3/8x1/8 combination had a yielding value around 14 kips. This load value for the 3/8x1/4 combination was 23 kips. In the next combination, 3/8x1/2, the connection gained some strength which was 26 kips. After this point the peak point remained at a value of 32 kips (Figure 3.4-2).

The plastic portions of these combinations were very alike where the slopes were concerned. The thinnest combination, 3/8x1/8, had a negative slope which was caused by the 1/8-in. plate. It started losing strength right after hitting the plastic part, which was the sign of the developing failure mode. The other combinations had positive slopes meaning they continued gaining strength. The 3/8x3/8 combination was the first of the bolt shearing failure. The 3/8x1/2 combination had shearing of the bolt with an ultimate load capacity of 34 kips and maximum deformation of 0.7 in. The preceding combinations also failed with the same failure mechanism; however, their bolt shearing

loads were around 37 kips. Both the 3/8x5/8 and 3/8x3/4 combinations had a maximum deformation of 0.2 in. where, unexpectedly, the 3/8x1 combination deformed 0.5 in. (Figure 3.4-2).

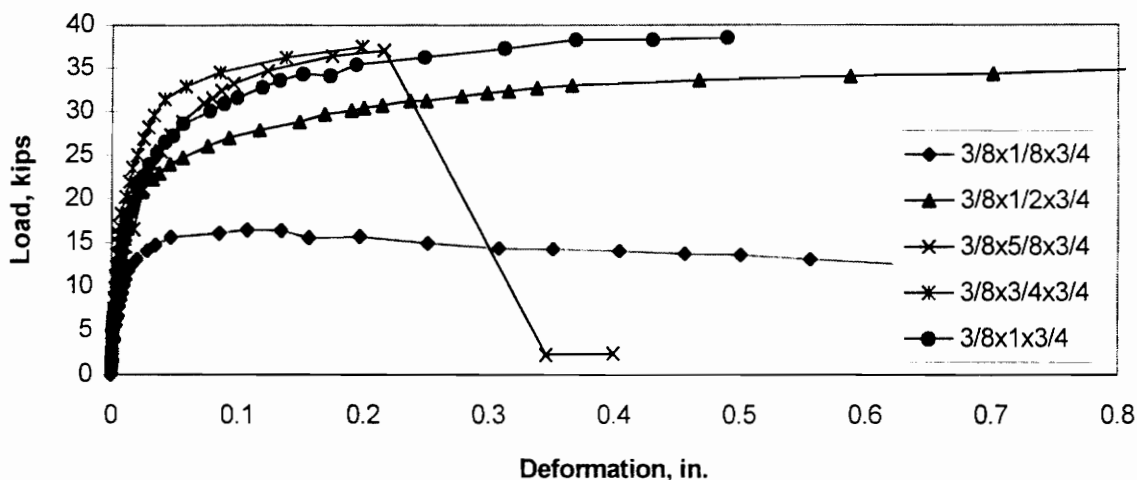

Figure 3.4-2
Data Overlay Of 3/8-In. Combinations With 3/4-In Bolts

3.4.2 7/8-in. Diameter Bolt

The initial stiffness had an increasing profile with the increasing thickness of the connection. The 3/8x3/4 combination was out of line, having a smaller value than 3/8x1/2 for its initial stiffness (Figure 3.4-3).

Although the excessive deformations that caused the connections to go into plastic mode have been determined by the thinner connected plate, the thicker plate seemed to

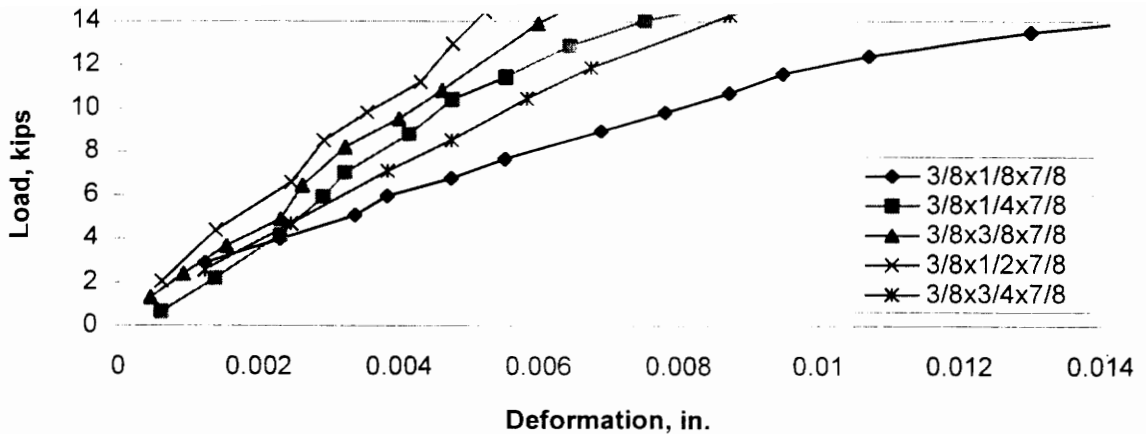

Figure 3.4-3
Initial Stiffness Comparison Of 3/8-In. Combinations With 7/8-In. Bolts

have a strengthening effect on the connection. The load where the rounding started raised gradually. The 3/8x1/8 combination had a yielding point of 18 kips. The next combination, 3/8x1/4, had 25 kips of load. The 3/8x3/8 and 3/8x1/2 combinations had maximum loads of 29 and 36 kips, respectively. However, the 3/8x3/4 combination lost some strength, having a yield initiation point of 34 kips (Figure 3.4-4).

The 3/8x1/8 combination started losing strength after the yielding and had negative plastic slope like the other combinations including 1/8-in. plates. It deformed 0.70 in. and the bulged part bent out of plane causing the connection to fail. The 3/8x1/4 combination maintained its strength at yielding in the plastic part of the curve. The slope was flat until the splitting of the bulged part occurred. The maximum deformation was around 0.8 in. The 3/8x3/8 combination gained strength in the plastic range as the

deformation increased. The plastic slope was the highest of all this group of combinations. The failure mode was the shearing of the bolt at 36 kips with a deformation of 1.0 in. The 3/8x1/2, and 3/8x3/4 combinations also failed with shearing of the bolt at 36 kips but their slope in this region were somewhat smaller than the 3/8x3/8 combination. Maximum deformations were around 0.9 in. (Figure 3.4-4).

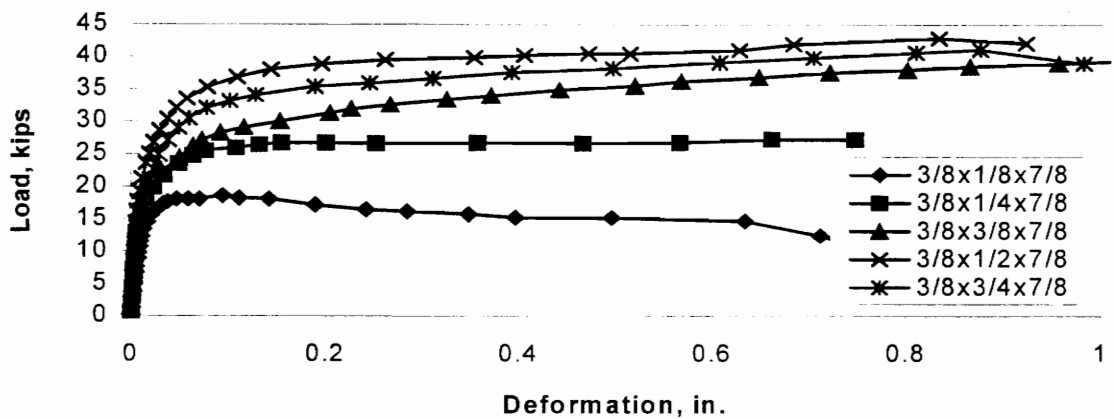

Figure 3.4-4
Data Overlay Of 3/8-In. Combinations With 7/8-In Bolts

3.4.3 1-in Diameter Bolt

The 3/8-in. combinations did not provide consistent data for evaluation of the initial stiffness and thickness relationship. As a rough observation, the slopes were almost the same except for the 1/4x1/4 combination. It had a lower slope value than the other combinations (Figure 3.4-5).

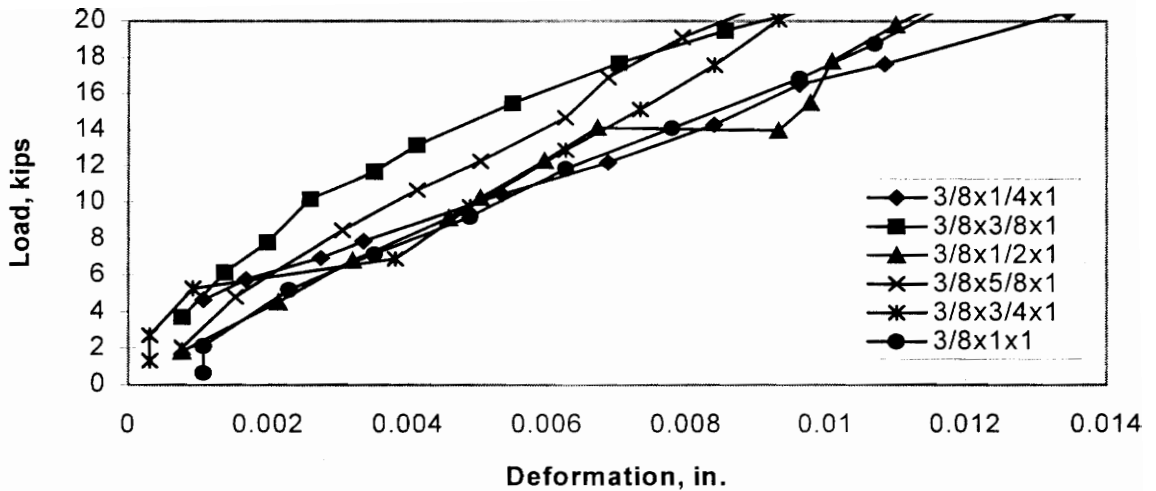

Figure 3.4-5
Initial Stiffness Comparison Of 3/8-In. Combinations With 1-In. Bolts

In the 3/8x1/4 combination, the yielding of the 1/4-in. plate determined the yielding load of the connection. At 32 kips, excessive deformations were observed and the connection did not gain any strength. It had a flat slope until failure, which was bearing and tear out that occurred at 1.5 in. of deformation. The next combination, 3/8x3/8, had a higher yielding point, 36 kips. This connection strengthened as the deformations in the bolt area increased. The next combinations had the same behavior. This is the case with 1/4-in. combinations with 1-in. diameter bolts. They started yielding at 42 kips and had positive slopes as they strengthened. The 3/8x1/2 combination failed at 1.2 in. of deformation with an ultimate load of 54 kips. The failure mode was bearing/tear out. The other combinations, 3/8x5/8, 3/8x3/4, and 3/8x1, failed at 0.8 in. and 43 kips (Figure 3.4-6). They failed with bearing/tear out also.

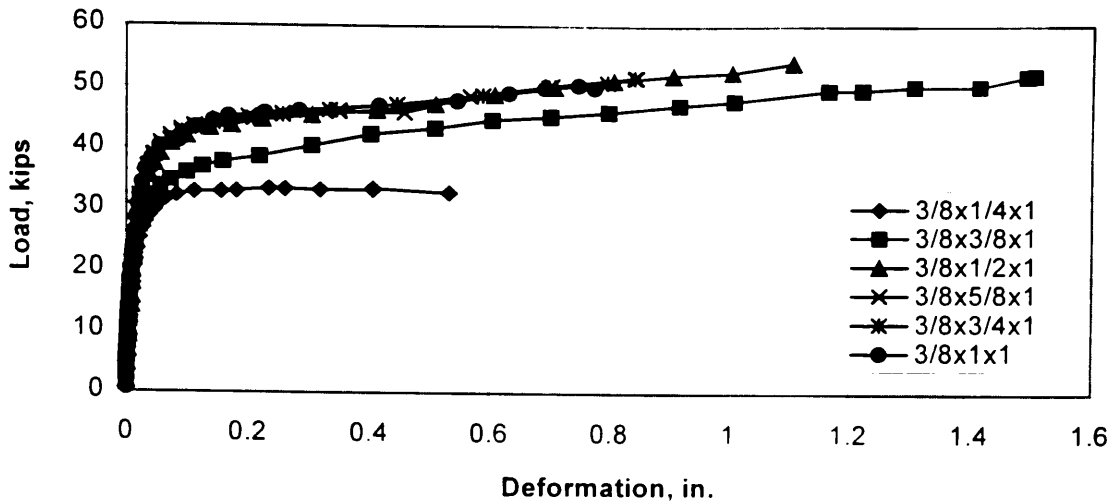

Figure 3.4-6
Data Overlay Of 3/8-In. Combinations With 1-In Bolts

3.5 1/2-IN. COMBINATIONS

3.5.1 3/4-in. Diameter Bolt

The thickness of the connection influenced the order of the initial stiffnesses like the other tests. The 1/2x1/8 combination was the least stiff and the combinations got stiffer with the increasing thickness of the connections (Figure 3.5-1).

The 1/2x1/8 combination had its peak load value at 16 kips with the influence of 1/8-in. plate. It had a rather short curved part. The 1/2x3/8 combination yielded at 27 kips which was quite an increase in strength. The 1/2x1/2, 1/2x5/8, and 1/2x1 combinations had the same yielding point of approximately 31 kips. It must be noted that

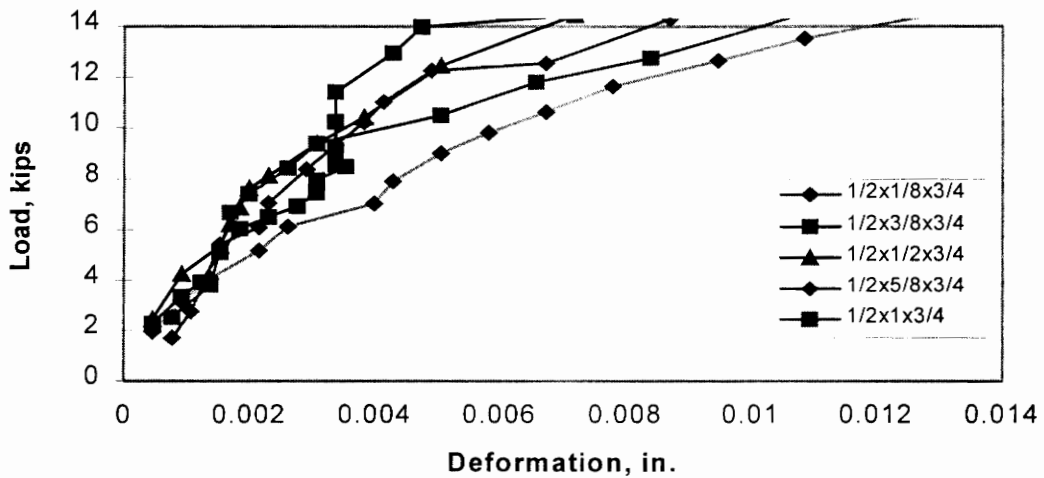

Figure 3.5-1
Initial Stiffness Comparison Of 1/2-In. Combinations With 3/4-In. Bolts

the 1/2x1 combination lost strength compared to the thinner combinations (Figure 3.5-2).

The strength loss of the connection with a 1/8-in. plate was typical for this group of combinations. It had a negative slope leading to a load value of 13 kips at 0.45 in. of deformation where it failed by the bending of the bulged part out of plane. The 1/2x3/8 combination had a positive slope which was bigger than the slopes of the thicker combinations. It failed with the shearing of the bolt at 36 kips and 0.5 in. of deformation. The other combinations also failed in the same manner at the same load of 37 kips. Their deformations were around 0.25 in. (Figure 3.5-2).

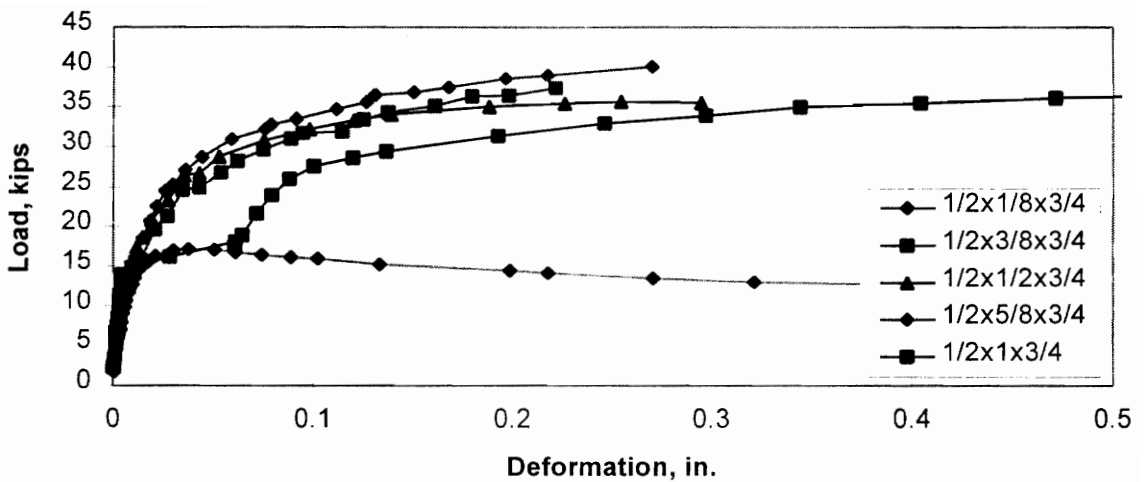

Figure 3.5-2
Data Overlay Of 1/2-In. Combinations With 3/4-In Bolts

3.5.2 7/8-in Diameter Bolts

The initial stiffnesses were in an increasing order by thickness of the connections. However, as before, the ductility of the connection decreased with the thickest combinations, 1/2x3/4 and 1/2x1 (Figure 3.5-3).

The first combination, 1/2x1/8, had a yielding load of 20 kips. The next combination gained strength so that it yielded at a value of 30 kips. The 1/2x3/8 combination started deforming excessively at 36 kips. The other combinations had a yielding initiation value of 44 kips. They had identical behaviors in this region of the load-deformation curve (Figure 3.5-4).

In the plastic region, the 1/2x1/8 combination maintained its strength for a short time and again started to decline. It failed with the bending of the bulged part out of plane when it had 0.65 in. of deformation. The failure occurred at 14 kips.

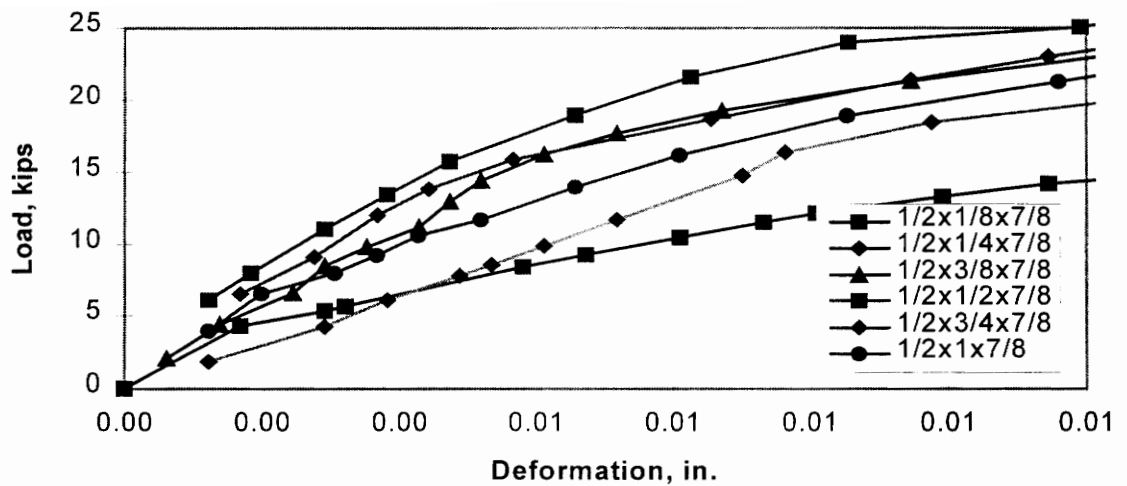

Figure 3.5-3
Initial Stiffness Comparison Of 1/2-In. Combinations With 7/8-In. Bolts

Although the 1/2x1/4 combination lost some strength, it had a rather flat plastic slope which was leveled at 30 kips. It failed with the splitting of the bulged part in front of the bolt after deforming 0.65 in. The 1/2x3/8 combination gained some strength with its slightly increasing curve in the plastic region. It had a maximum deformation of 0.95 in. where it failed with bearing and tear out. The other combinations failed with the shearing of their bolts at 50 kips deforming 0.40 in. They did not have well-defined plastic slopes because the failure mode occurred in an early stage of the plastic portion (Figure 3.5-4).

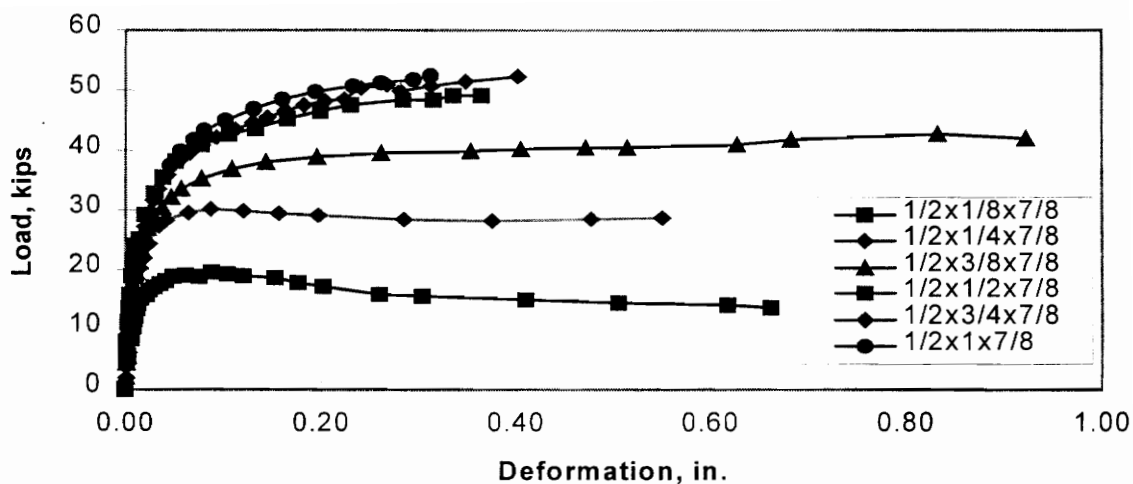

Figure 3.5-4
Data Overlay Of 1/2-In. Combinations With 7/8-In Bolts

3.5.3 1-in. Diameter Bolt

The initial stiffness of this group of combinations increased until 1/2x1/2 and remained constant afterwards. The 1/2x1/4 combination was the least stiff of all, followed by the 1/2x3/8 combination (Figure 3.5-5).

The 1/2x1/4 combination continued its elastic state until 34 kips and yielded. It kept its strength while the deformation increased. The failure was a splitting of the bulged part at 0.95 in. On the other hand, tearing out was also developing when the failure occurred. The 1/2x3/8 combination increased its strength with a positive slope

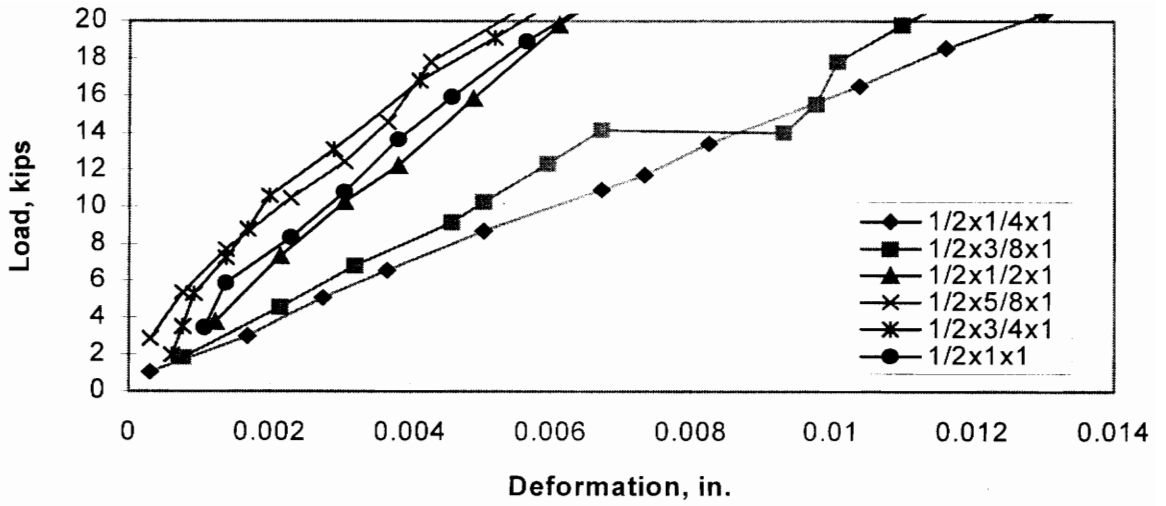

Figure 3.5-5
Initial Stiffness Of 1/2-In. Combinations With 1-In. Bolts

after yielding at 40 kips. It failed with bearing and tear out at 54 kips and 1.15 in. of deformation. The following combinations, 1/2x5/8, 1/2x3/4, and 1/2x1, failed with the shearing of the bolts around 61 kips. The maximum deformations were around 0.65 in. while the 1/2x1/4 combination deformed only 0.25 in. (Figure 3.5-6).

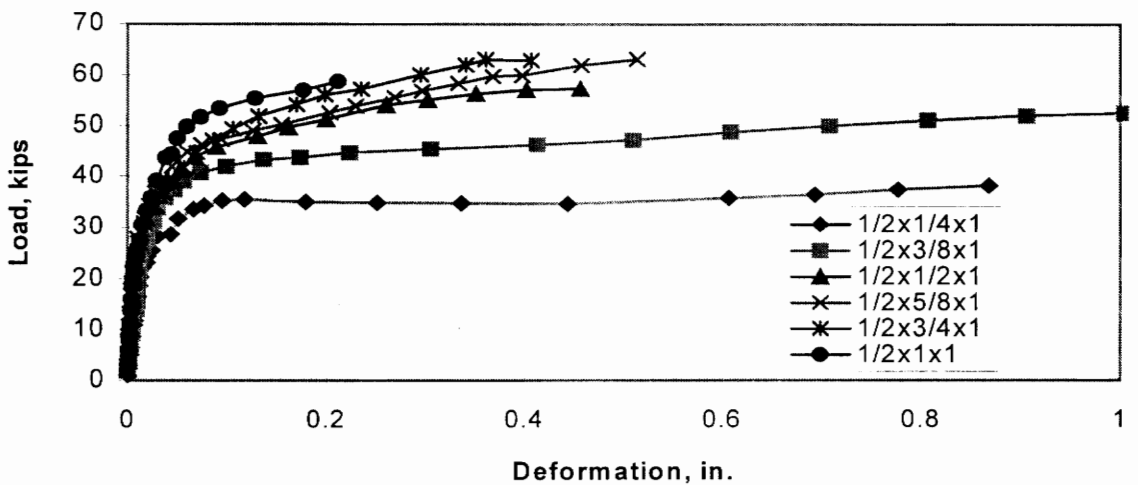

Figure 3.5-6
Data Overlay Of 1/2-In. Combinations With 1-In. Bolts

3.6 5/8-IN. COMBINATIONS

The combinations that had 5/8-in. plates as the fixed parameter were tested with 3/4 and 1-in. bolt diameters.

3.6.1 3/4-in. Diameter Bolt

This group of combinations also exhibited the same behavior with other combinations for their initial stiffnesses. The initial stiffness was apparently a function of the thickness of the connection. The 5/8x1/8 combination had the least stiffness as it was the thinnest of all. The 5/8x1/4 combination was a little stiffer. This was the same with the 5/8x1/2 combination. The other combinations were stiffer (Figure 3.6-1).

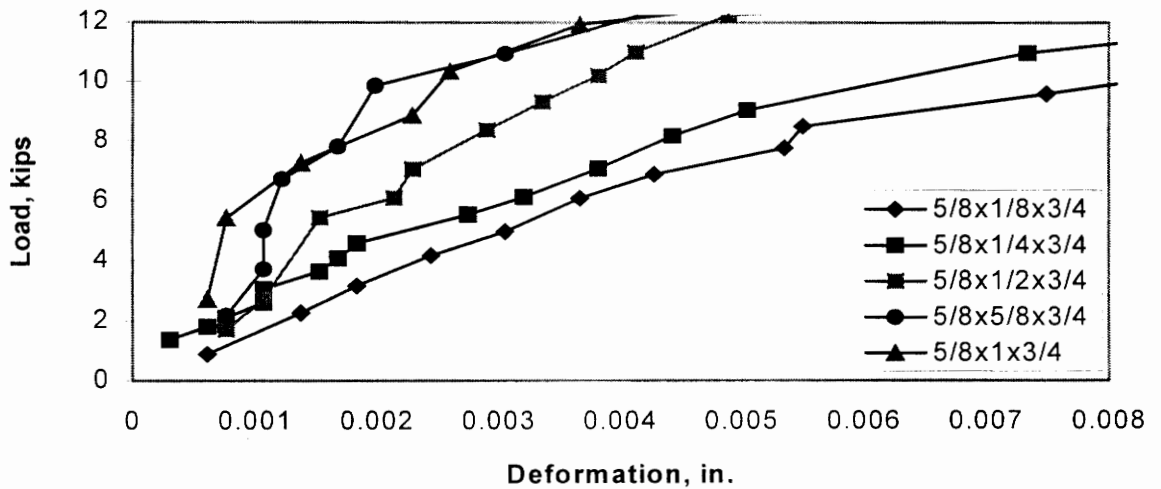

Figure 3.6-1
Initial Stiffness Comparison Of 5/8-In. Combinations With 3/4-In. Bolts

The effect of the thinner plate in the combination was observed in the first two tests, 5/8x1/8 and 5/8x1/4. The first one started deforming excessively at a load of 15 kips and the 5/8x1/4 combination gained strength and yielding started at 25 kips. Both the 5/8x1/2 and 5/8x1 combinations behaved identically yielding at 31 kips. However, 5/8x5/8 lost some ductility and strength. The yielding load was 29 kips (Figure 3.6-2).

The 5/8x1/8 combination began to lose strength in the plastic portion and failed by excessive bending of the bulged part at the tip of the plate. The maximum deformation was 0.6 in. with a failure load of 13 kips. The 5/8x1/4 combination kept up its strength in this region and had a flat plastic slope that leveled at 28 kips. It failed with the tearing out of the plate at 0.7 in. of deformation. The 5/8x1/2, 5/8x5/8 and 5/8x1 combinations could not develop plastic slopes because of the shearing of the bolts at 38 kips. They failed at 0.2 in. of deformation (Figure 3.6-2).

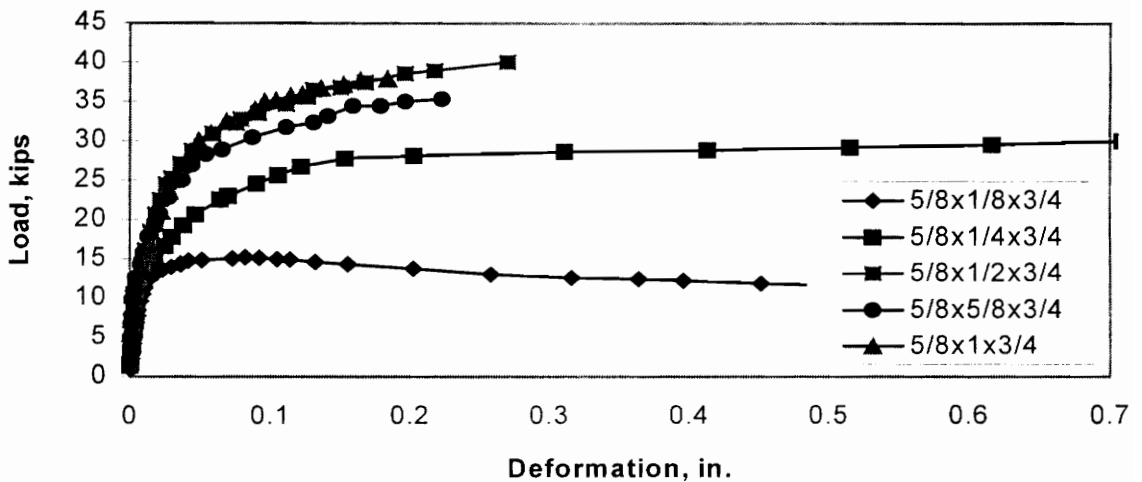

Figure 3.6-2
Data Overlay Of 5/8-In. Combinations With 3/4-In Bolts

3.6.2 1-in. Diameter Bolts

The initial stiffness of the 5/8-in. combinations increased with the increasing thickness of the connection as observed with the other combinations. The thinnest combination, 5/8x1/4, started yielding at 30 kips where the other combinations, 5/8x3/8, 5/8x1/2, 5/8x3/4, yielded at approximately 40 kips. The 5/8x1/4 and 5/8x3/8 combinations maintained their strength with a flat slope. The 5/8x1/4 combinations failed at 34 kips and 5/8x3/8 failed at 45 kips with bearing/tear out failures. The other thicker combinations failed with bolt shear. The 5/8x1/2 combination failed at 63 kips and 5/8x3/4 combination failed at 66 kips. The thickness of the connection increased the failure load value.

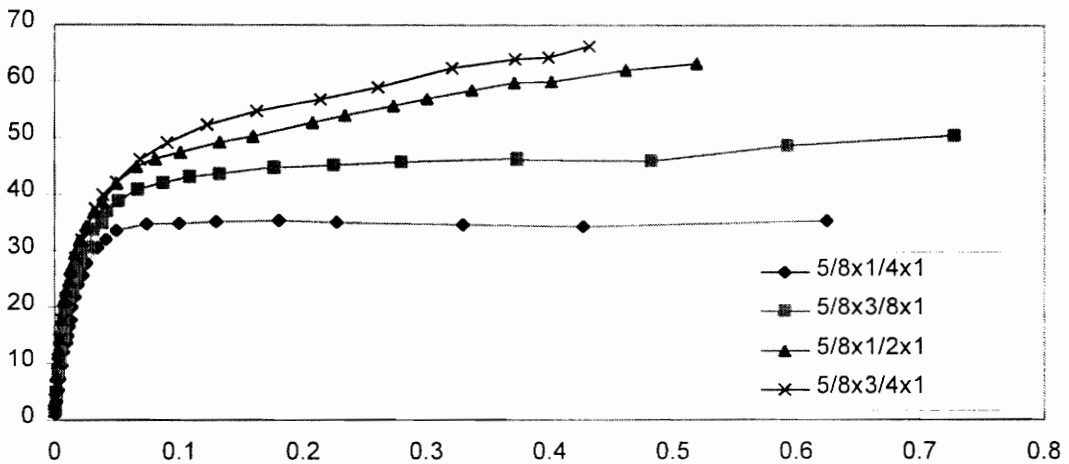

Figure 3.6-3
Data Overlay Of 5/8-In. Combinations With 1-In. Diameter Bolt

3.7 3/4-IN. COMBINATIONS

These combinations had 3/4-in. thick plates as fixed thickness plate and tested with 7/8-in. and 1-in. bolt diameters.

3.7.1 7/8-in. Diameter Bolt

The initial stiffnesses increased due to the increasing thickness of the connection. The 3/4x3/4 and 3/4x1 combinations had almost the same initial stiffness (Figure 3.7-1).

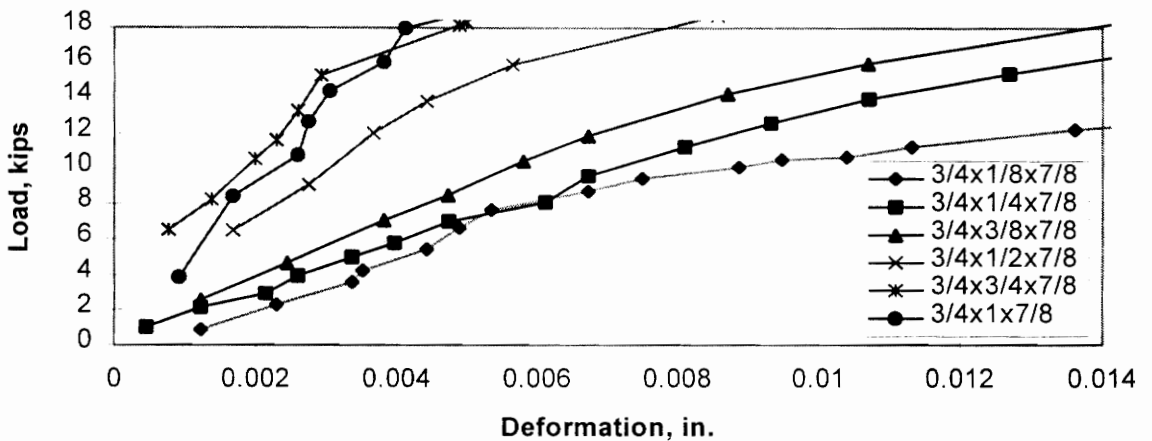

Figure 3.7-1
Initial Stiffness Comparison Of 3/4-In. Combinations With 7/8-In. Bolts

The influence of the connection thickness was observed to be affecting the strength of the connection. The 3/4x1/8 connection had its yielding point at 15 kips and

that was the end of strength acquisition. The 3/4x1/4 combination went up to 26 kips. The next combination, 3/4x3/8, had excessive deformations after 32 kips. In all the other combinations, 3/4x1/5, 3/4x3/4 and 3/4x1, the yielding initiated at 40 kips (Figure 3.7-2).

In the plastic region, the 3/8x1/8 combination behaved like the other 1/8-in. combinations. Somehow, it maintained its strength for some time and had a negative slope afterwards. This was probably the effect of the thick plate that formed the connection. The slope had a smaller value than the previous tests that included a 1/8-in. plate. It failed with splitting in the bulged part at 14 kips. The deformation was around 0.80 in. The 3/4x1/4 combination maintained its strength till the failure at 26 kips where the curve leveled. The failure mode was tearing out at a maximum deformation of 0.75 in. The 3/4x3/8 combination had a flat slope. It failed after deforming 0.95 in. with splitting at the bulged part. The ultimate load capacity was 41 kips. The thicker combinations, 3/4x1/2, 3/4x3/4 and 3/4x1, had shearing of the bolts at 0.30 in. of deformation and 50 kips (Figure 3.7-2).

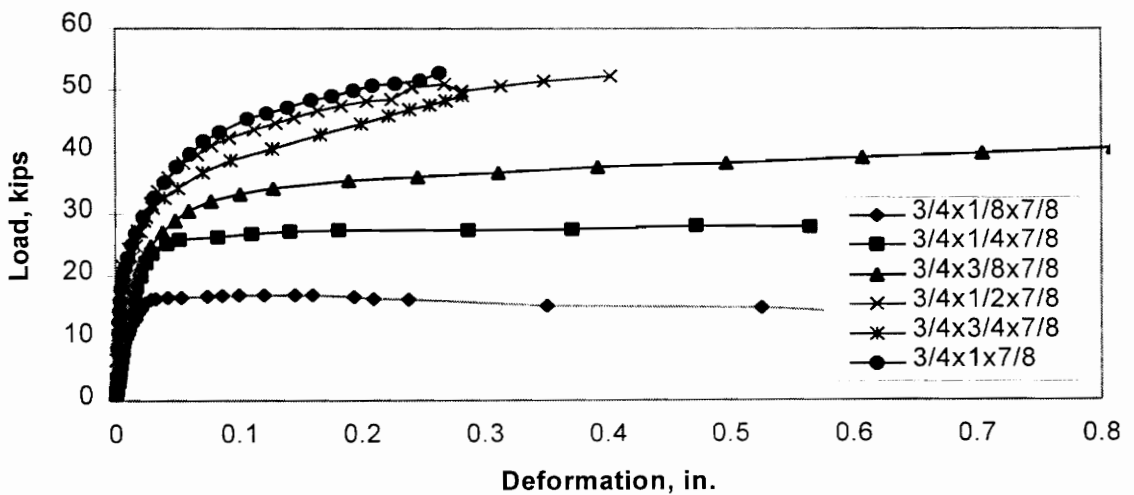

Figure 3.7-2
Data Overlay Of 3/4-In. Combinations With 7/8-In Bolts

3.7.2 1-in. Diameter Bolt

In the 3/4-in. combinations with 1-in. diameter bolts, the initial slope increased with the thickness of the connection. The excessive deformations in the connections began approximately at 35 kips. The 3/4x1/4 combination had a flat plastic slope. The 3/4x3/8 combination gained strength with the positive plastic slope. The other combinations, 3/4x1/2 and 3/4x3/4, had bolt shear failure, so they did not have a plastic region. The failure loads were 36 kips, and 50 kips for 3/4x1/4 and 3/4x3/8 which failed with bearing/tear out. The others failed with bolt shear at 62 kips (Figure 3.7-3).

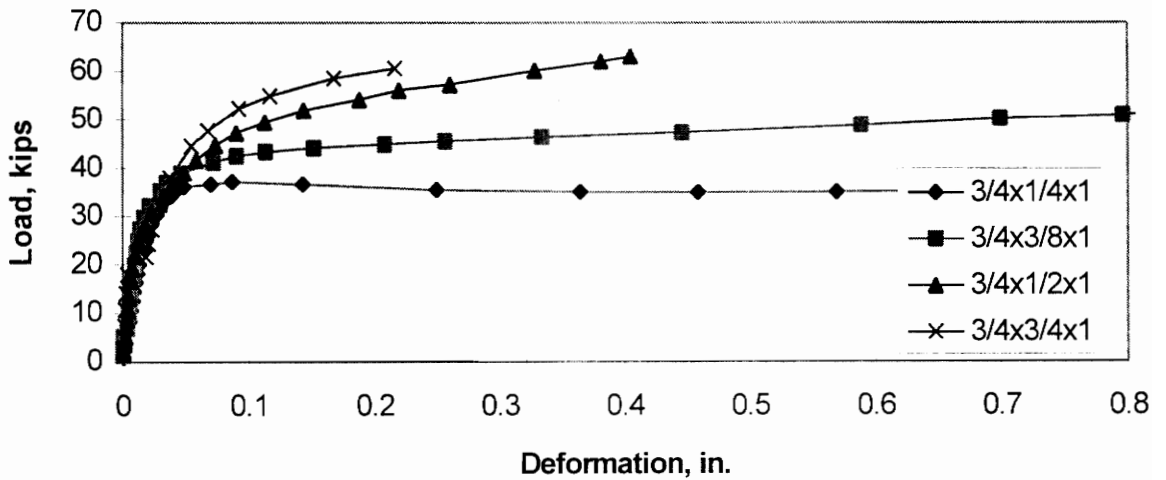

Figure 3.7-3
Data Overlay Of 3/4-In. Combinations With 1-In Bolts

3.8 1-IN. COMBINATIONS

This group of combinations was tested with 3/4-in., 7/8-in., and 1-in. diameter A325 bolts.

3.8.1 3/4-in. Diameter Bolt

An increase in the initial slopes of the curves was also observed in these tests. The thinnest combination, 1x1/8, had the least slope. However, the 1x1/4 combination was stiffer than the 1x3/8 combination. All the others had increasing stiffnesses due to their thicknesses (Figure 3.8-1).

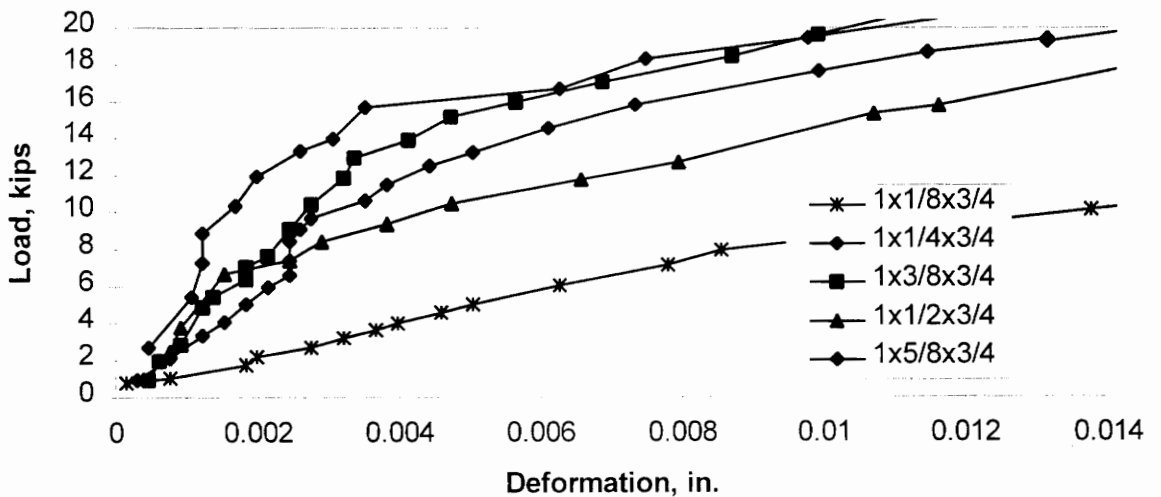

Figure 3.8-1
Initial Stiffness Of 1-In. Combinations With 3/4-In. Bolts

After the elastic portion, the 1x1/8 combination started to yield at 12 kips, which was considerably less than the other combinations. This value for the 1x1/4 combination was 24 kips. The other combinations, 1x3/8, 1x1/2x and 1x5/8, had the same load of 31 kips. It must be noted that they failed with bolt shear. Their strengths kept rising before the plastic portion (Figure 3.8-2).

The 1x1/8 combination had a flat plastic slope leveling at 12 kips. It did not gain any strength. Failure came at a deformation of 1.2 in. with the splitting of the bulged part. The 1x1/4 combination lost some of its strength on the way to failure. It had a negative slope.

It failed at 0.5 in. with splitting. In the other combinations, the load exceeded the capacity of the bolt and failure mode was shearing of the fastener. So, except for 1x3/8, the connections could not develop a well-defined plastic region. They failed at 36 kips. However, 1x3/8 could deform 0.45 in. with a slight slope. It also failed at 36 kips (Figure 3.8-2).

The initial stiffnesses were lined up in order by means of thickness of the connection, except for the 1x1/2 combination which was less stiff than 1x1/4. The effect of the thickness of the connected plates played the greatest role in determining the slope of the curve.

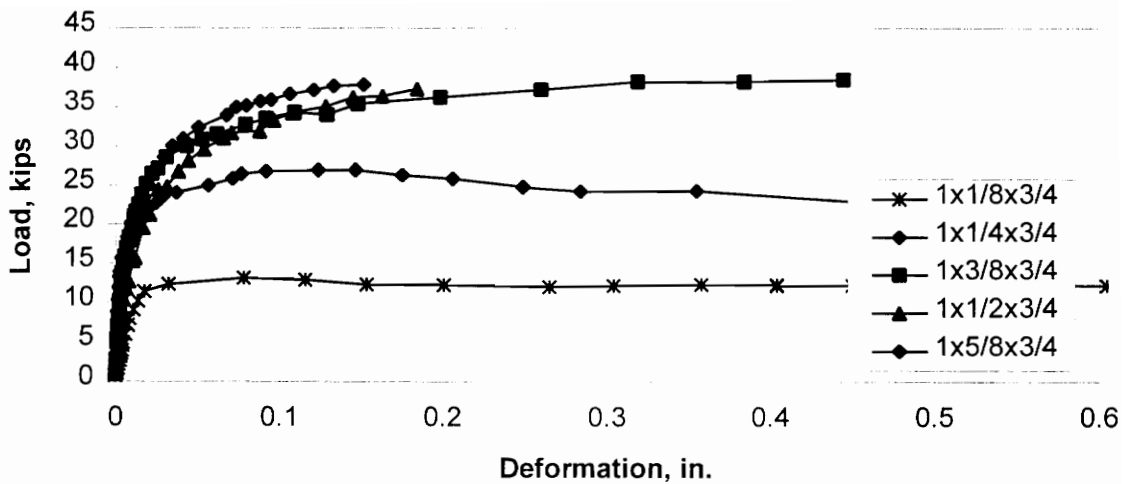

Figure 3.8-2
Data Overlay Of 1-In. Combinations With 3/4-In Bolts

3.8.2 7/8-in. Diameter Bolt

The 1x1/4 combination gained strength until hitting 28 kips where the excessive deformations in the 1/4-in. thick plate began. After that point, the connection maintained its strength until the failure at 0.65 in. The failure was splitting in the bulged part, but the tear out failure seemed to be about to occur. The other combinations, 1x1/2, 1x5/8, and 1x1, failed with the shearing of the bolts at 36 kips and 0.2 in. of deformation (Figure 3.8-3).

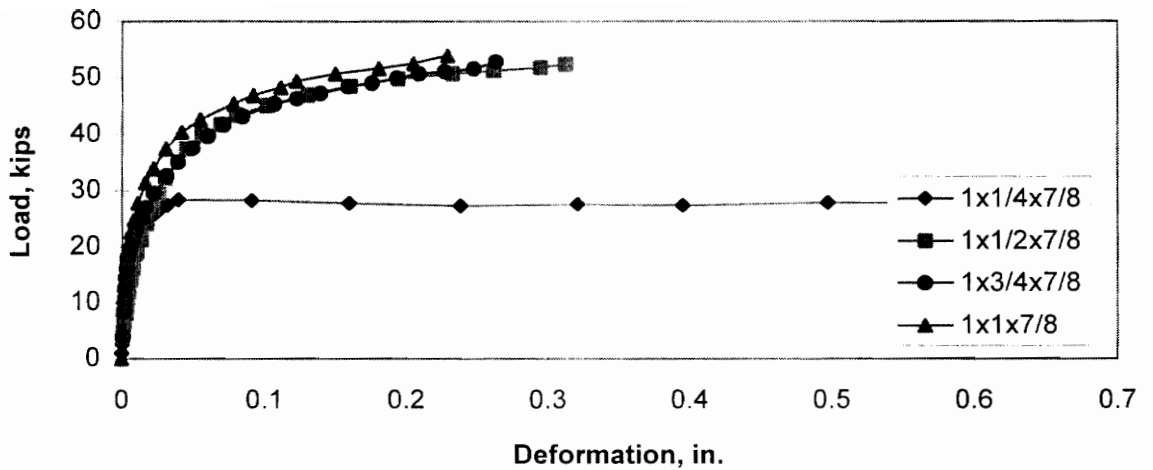

Figure 3.8-3
Data Overlay Of 1-In. Combinations With 7/8-In Bolts

3.8.3 1-in. Diameter Bolt

Figure 3.8-4 shows the general look of the 1-in. combinations with a 1-in. diameter bolt. The 1x1/4 and 1x3/8 combinations failed with bearing/tear out at 46 kips and 52 kips, respectively. The deformations were approximately 0.8 in. The 1x1/5 and 1x5/8 combinations failed by shearing of the bolt. In the 1x1/2 combination, the bolt sheared at the threaded part, so it had less strength than 1x5/8. The ultimate loads were 60 kips and 66 kips, respectively.

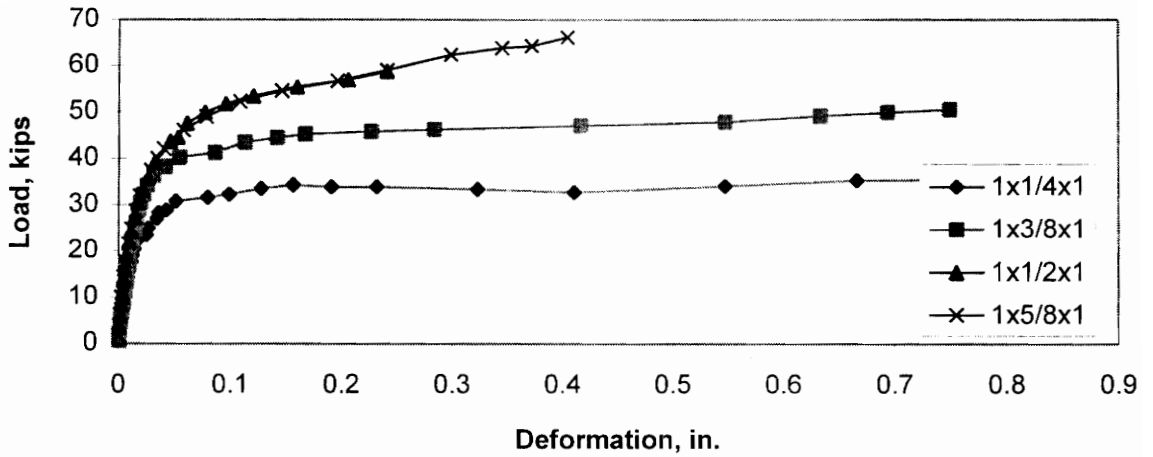

Figure 3.8-4
Data Overlay Of 1-In. Combinations With 1-In Bolts

3.9 TESTS WITH REDUCED EDGE DISTANCE $L_e=1.5d_b$

The last part of the testing program consisted of the tests with reduced edge distance. These tests were intended to investigate the effect of less material in front of the bolt.

The behaviors of the connections did not change remarkably except for the yielding point and the plastic slope. The yielding point decreased as would be expected. The $1.5d_b$ tests did not soften as the $2.0d_b$ tests, instead they went up to the yielding point with continuous initial slope, and curved later. In most of the tests, the plastic slope was almost flat.

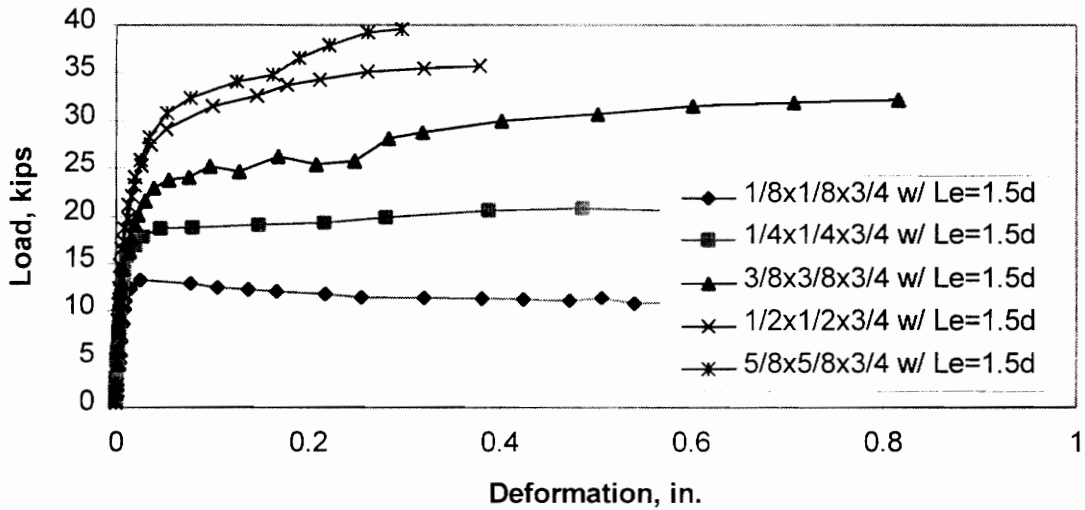

Figure 3.9-1
Data Overlay Of Tests with $L_e=1.5d_b$

3.10 DISCUSSION OF TEST RESULTS

The remaining parts of this chapter are devoted to discussing the results of the tests for the determination of the load-deformation behavior of the bolted connections. The tests that were conducted provide diverse information on the topic, as a wide variety of variables were considered in the program.

Load-deformation curves are plotted for each test to get a view of the curvature that represents the behavior of the bolted connection. As seen in previously conducted research, the curves look the same with differences caused by the varied geometry and material properties of the test specimens. The different regions of the curve will be investigated individually.

3.11 GENERAL BEHAVIOR OF A BOLTED CONNECTION

The load-deformation curve of a bolted connection has five important characteristics:

- 1) Initial slope of the curve,
- 2) Linear elastic region;
- 3) Yielding region;
- 4) Plastic slope;
- 5) Plastic region.

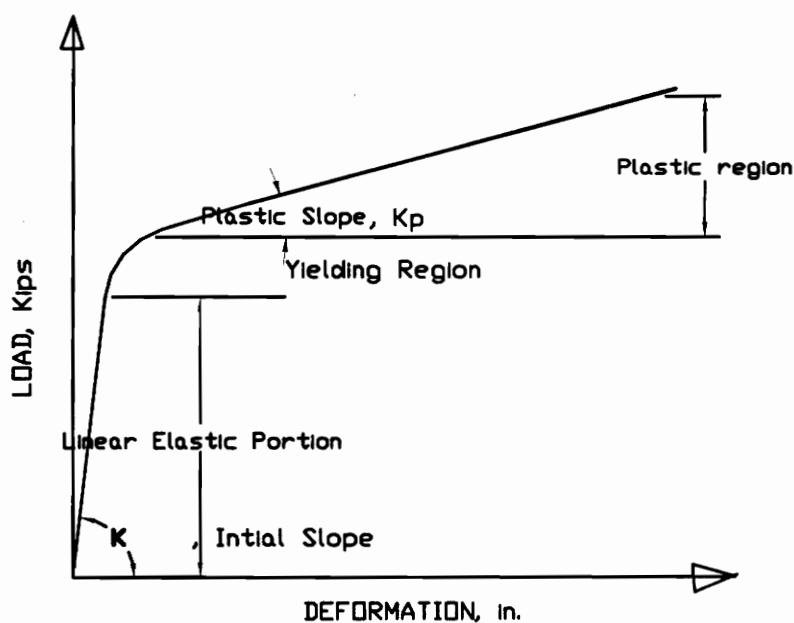

Figure 3.11-1
General Behavior of Bolted Connections

The curve starts to ascend with an initial slope. It exhibits linear behavior until the thinner of the connected plates comes to a yielding point. This region is going to be

referred to as the elastic part of the curve, as the deformations are elastic. Excessive deformations in front of the bolt occur after that point. Visual differences are noticed with the flaking of the whitewash at the yielding regions which are the front of the bolt and the sides in line with the bolt. Flaking in this region is caused by the out of plane bending of the plates. As the loads get higher, the bolts incline which induces an eccentricity on the connection. This region has a rounded curvature and is referred to as yielding region.

When the plastic region is entered, the curve gets linear again, but not as steeply as the initial slope. It indicates the capacity of gaining strength after the yielding of the plates. Some connections had negative slopes which indicates loss of load carrying capacity; some maintained their strength with a zero slope while others gained strength with positive ones.

Bulging at the edge of the plate gets larger with an increasing load. The bolt hole stretches. Bearing/tear out failures take place as an effect of these excessive deformations in front of the bolt.

The failure is the last step in the behavior of a bolted connection. The failure modes will be investigated later.

3.12 LOAD-DEFORMATION CURVE

3.12.1 Elastic Region (Initial Slope and Linear Elastic Portion)

The elastic region consists of two parts-- initial slope and a linear elastic portion. The deformations in this part are in the range of 0~0.025 in. The thickness of the connection affects the length and the slope of this initial portion.

All of the tests have the same characteristic for this region; the curve rises with a constant slope up to a point of yielding where excessive deformations start. The slope is a factor of the thinner of the connected plates. The second plate in the connection has an indistinctive effect on the slope. Table 3.12-1 shows the initial and plastic slope values of the tests. Looking at the data, it can be noticed that the initial slopes have increasing values when the thinner of the connected plates is increased. However, the contribution of the second plate is random. The effect of bolt size on the initial slope is undetermined. In some cases, it decreased with increasing bolt size (1/8-in. and 1/4-in. combinations). On the other hand, it increased with increasing bolt size in other cases (3/8-in. and 1/2-in. combinations). It must be taken into account that the deformations in this stage of the tests are so small that they can be affected easily by any imperfections in the test setup.

Table 3.12-1 K and K_p Values of Individual Tests

TEST NO.	CONNECTION	K	K _p
1	1/4x1/4x3/4	1791	4.71
2	1/4x3/8x3/4	2181	8.64
3	1/4x1/2x3/4	1892	11.36
4	1/4x5/8x3/4	1514	5.61
5	1/4x1x3/4	2086	-12.07
6	1/8x1/8x3/4	1035	1.11
7	1/8x1/4x3/4	1063	-4.95
8	1/8x3/8x3/4	995	-7.97
9	1/8x1/2x3/4	1471	-12.47
10	1/8x5/8x3/4	1261	-8.31
11	3/8x3/8x3/4	2463	17.66
12	3/8x1/2x3/4	2464	14.87
13	3/8x5/8x3/4	1671	0
14	3/8x3/4x3/4	1959	26.57
15	3/8x1x3/4	1649	13.36
16	1/2x1/2x3/4	2694	16
17	1/2x5/8x3/4	2916	24.84
18	1/2x1x3/4	1538	48.96
19	5/8x5/8x3/4	3415	37.19
20	5/8x1x3/4	4593	26.3
21	1x1x3/4	4010	29
22	1/8x1/8x7/8	910	-7.8
23	1/8x1/4x7/8	993	-7.28
24	1/8x3/8x7/8	1170	-10.6
25	1/8x1/2x7/8	987	-10.3
26	1/8x3/4x7/8	941	-7.1
27	1/4x1/4x7/8	1718	4.95
28	1/4x3/8x7/8	2028	1.35
29	1/4x1/2x7/8	1736	0.5
30	1/4x3/4x7/8	1361	4.3
31	1/4x1x7/8	1760	0.5
32	3/8x3/8x7/8	2450	8.11
33	3/8x1/2x7/8	2622	7.34
34	3/8x3/4x7/8	1782	10.2
35	1/2x1/2x7/8	3081	22.8
36	1/2x3/4x7/8	2621	33.5
37	1/2x1x3/4	2732	40.51
38	3/4x3/4x7/8	3336	61.1
39	3/4x1x7/8	3562	49.5
40	1x1x7/8	3994	79.2
41	1/4x1/4x1	1423	8.6
42	1/4x3/8x1	1813	5.1

Table 3.12-1 K and K_p Values of Individual Tests (Continued)

TEST NO.	CONNECTION	K	K _p
43	1/4x1/2x1	1644	4
44	1/4x5/8x1	1765	2
45	1/4x3/4x1	1528	0
46	1/4x1x1	1665	2.2
47	3/8x3/8x1	2882	9.5
48	3/8x1/2x1	2237	12.7
49	3/8x5/8x1	2327	10.2
50	3/8x3/4x1	2454	10.4
51	3/8x1x1	1622	9.3
52	1/2x1/2x1	2983	22.8
53	1/2x5/8x1	3714	30.2
54	1/2x3/4x1	3637	34.6
55	1/2x1x1	3127	59.6

	1/8	3/8	1/2	5/8	3/4
3/4	1165	2041	2383	4004	3449
7/8	1023	2285	2811		
1		2304	3365		

3.12.2 Yielding Region

At some point during the loading process, excessive deformations on the connection are observed. The load-deformation curve tends to round as a result of this. This region after the first linear part is recognized as the yielding part of the curve. It has been observed that tested connections exhibited different behaviors mostly in this region.

The beginning of the yielding region is a factor of the shear yielding of the thinner plate in the connection. Also, the bending of the bolt adds some deformation at this stage. However, the length of this part seems to be random among the groups of combinations. It has been observed that the radius of the rounded part increased with

increasing thickness of the thinner plate. This is also related to the profile of the plastic portion.

3.12.3 Plastic Region

The last part of the load-deformation curve is the portion where the deformations are plastic. Three behavior types have been observed in the testing program. The first one was a positive slope which indicates the gaining of strength after the yielding. The 1/4-in. and 3/8-in. combinations which failed with bearing/tear out showed this behavior. The bolt shear failure tests had larger plastic slope values than the bearing/tear out failures. Secondly, some plastic slopes were almost flat; they neither lost nor gained strength. This behavior was observed with most of the 1/4-in. combinations. The third one was the negative slope observed in the 1/8-in. combinations. The probable reason for this might be the out of plane bending of the deformed material in front of the bolt, close to the edge.

3.13 ANALYTICAL MODELS

3.13.1 Load-Deformation Models

There are two analytical models available for determining the load-deformation behavior of the single bolt, single shear connections:

- 1) AISC model;
- 2) Richard's model.

These models are equations that were constructed to relate deformation of the connection to the load exerted, and have been mentioned before in the literature review. The applicability of the models will be investigated in this part.

3.13.1.1 AISC Model

AISC currently uses the load-deformation model developed by Fisher (1965). Crawford and Kulak (1971) used it for the analysis of eccentric loads on fastener groups with the *Instantaneous center of rotation* method.

The relationship was given as:

$$R = R_{ult} \left(1 - e^{-10\Delta}\right)^{0.55} \quad (\text{Eq. 3.13-1})$$

R= Shear force in a single fastener at any given deformation

R_{ult}= Ultimate shear load of a single fastener

Δ= Total deformation of a fastener including shearing, bending, and bearing deformation, plus local bearing deformation of the plate.

e= Base of natural logarithm= 2.718...

The method has been designed for a maximum deformation of 0.34 in. The parameters of the equation, -10 and 0.55, have been tabulated from a curve fitting study.

Comparisons between load-deformation curves that have been obtained from data in this study and AISC's load-deformation model have shown differences. As seen in

Figures 3.13-1 and 3.13-2, the available model ignores the essential parts of the actual curve. Therefore, it is insufficient in reflecting the actual behavior under tensile loads.

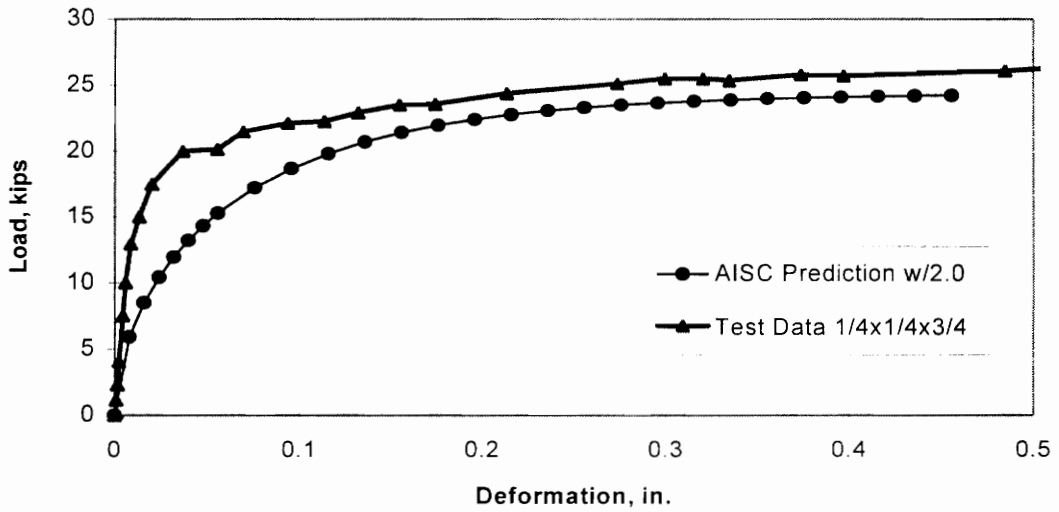

Figure 3.13-1
Comparison of Test Data with AISC Model

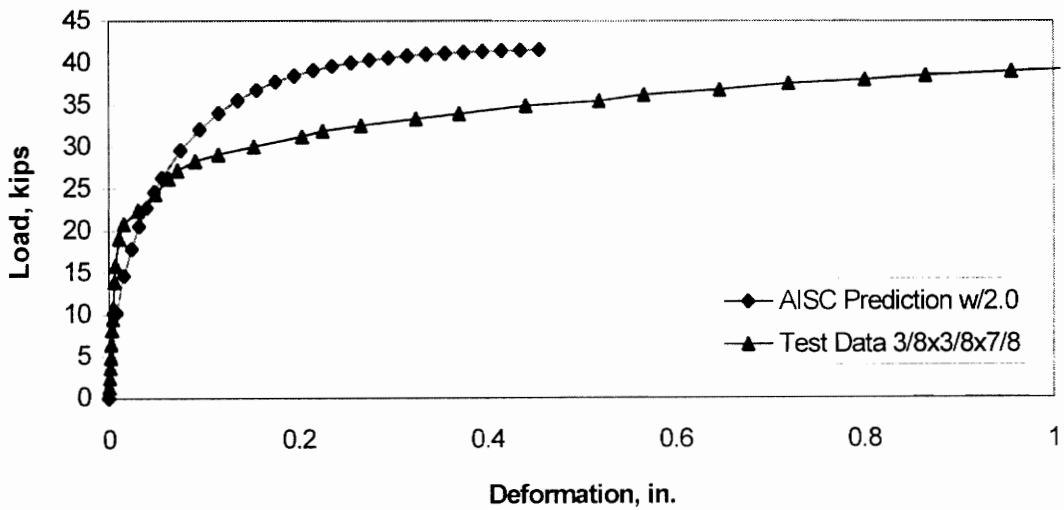

Figure 3.13-2
Comparison of Test Data with AISC Model

In Figure 3.13-1, it can be seen that the yielding region does not agree with the actual load-deformation curve. Figure 3.13-2 shows the incompatibility of the plastic region of the AISC model with the real curve. The problem addressed here is concerned with the parameters that are being used in the equation. It is obvious that a modification of those parameters is needed in order to get better fitting curves. In the testing program, some trends have been observed due to the material and geometrical properties; therefore, the equation should reflect the influence of these properties. The possibility of this issue is going to be investigated in Chapter 4.

Another problem associated with the AISC curve is the fact that it does not represent the unique behavior that 1/8-in. plates displayed. This group of combinations had a drastic loss of strength right after yielding. Curve fitting studies have shown that Eq. 3.13-1 does not have the capability of going beyond $y=1$ line (Figure 3.13-3).

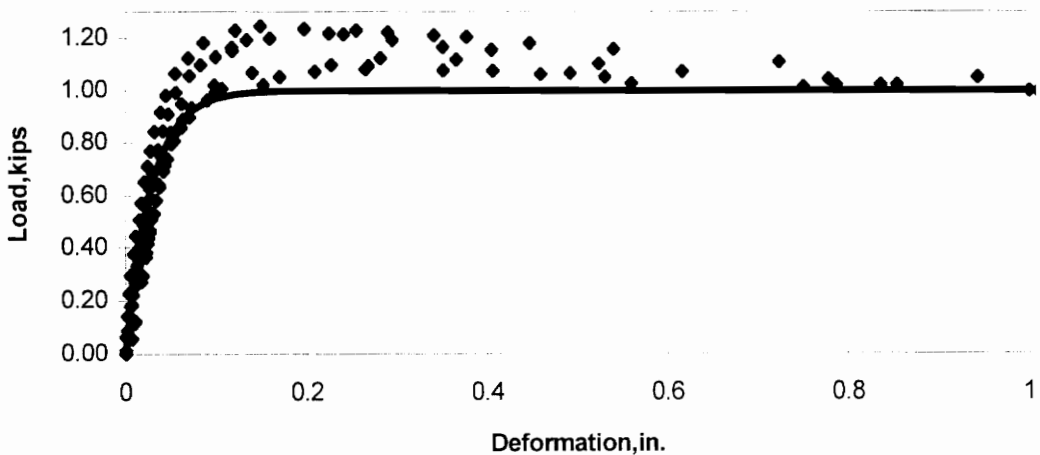

Figure 3.13-3
Comparison AISC Equation with 1/8-in. Combination Data

In Appendix C, comparisons of test data and the AISC model have been included.

3.13.1.2 Richard's Model

Richard (1980) proposed another analytical model for the determination of the actual load-deformation behavior of bolted connections. The expression is:

$$R = \frac{K_1 \Delta}{\left[1 + \left| \frac{K_1 \Delta}{R_0} \right|^n \right]^{\frac{1}{n}}} + K_p \Delta \quad (\text{Eq. 3.13-2})$$

where

R= Bolt force, kips;

Δ = Deformation, in;

K= Initial slope;

K_p = Slope of the extreme yielding range;

$K_1 = K - K_p$;

n= Curve fitting parameter.

This model has certain advantages over the AISC model. It consists of parameters to count for the different regions of the load-deformation curve. However, in Richard's study these parameters have not been generalized to be applicable to different cases. A curve fitting study has been included with parameters that match his test data.

The load-deformation curves that were obtained from Richard's model and parameters showed similarities in most cases, especially in bearing/tear out failure cases in which two curves matched almost perfectly. There was slight dissimilarity in the

plastic region. This was the result of the different material properties of the specimens used in the testing (Figure 3.13-4).

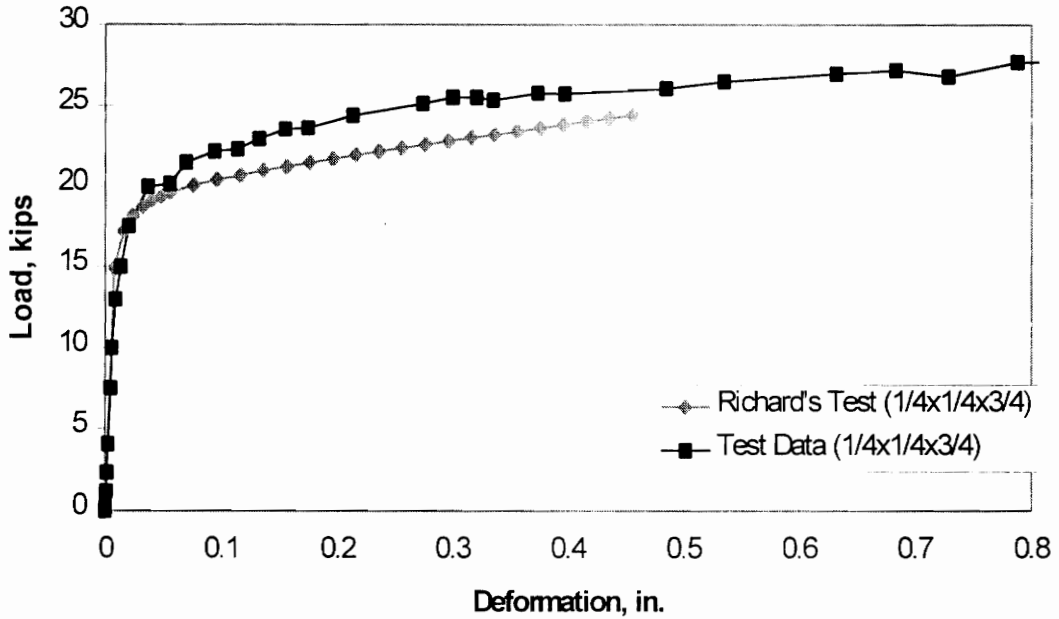

Figure 3.13-4
Comparison of Richard's Test Data with Our Data (Bearing/Tear Out)

The parameters suggested for the bolt shear failures did not reflect the behavior that was observed in our tests. As seen in Figure 3.13-5, the difference is noticed in the plastic region. The bolt shear failure occurs at very early deformations such as 0.2 in.; therefore, the connection does not have time to develop a well-defined plastic region.

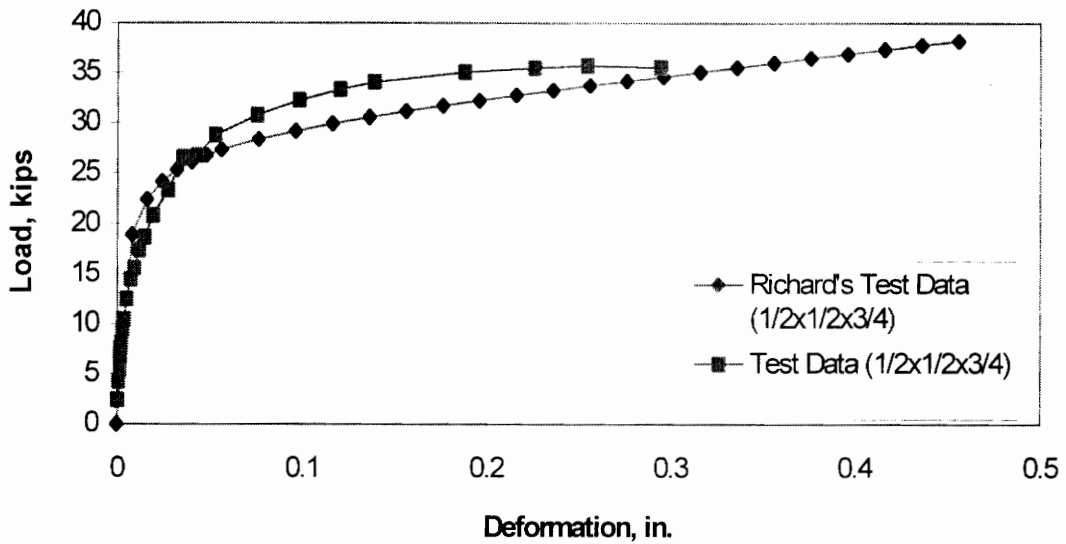

Figure 3.13-5
Comparison of Richard's Test Data with Our Data (Bolt Shear)

3.13.2 Strength Models

As discussed earlier, there are a number of failure mechanisms that are associated with single bolt, single shear connections. In the testing program, bearing/tear out, splitting, and bolt shear failure have been observed. The models that are used for them will be discussed in order to verify their applicability.

3.13.2.1 Bearing/Tear Out and Splitting

Bearing/tear out and splitting failures have been observed mostly in the testing program. Out of 70 tests, 20 bearing/tear out and 20 splitting failures were reported. The

mathematical model for the prediction of bearing/tear out failure has been derived previously. The expression is:

$$R_n = 1.4F_u t \left(\frac{L_e}{d} - \frac{1}{2} \right) \quad (\text{Eq. 3.13-3})$$

R_n = Design bearing strength of a single bolt;

L_e = Edge distance;

d = Diameter of bolt;

F_u = Tension rupture strength of the plate.

However, in LRFD, for a single bolt in line of the force, the ultimate bearing strength is given as:

$$R_n = L_e F_u t \leq 2.4 F_u t \quad (\text{Eq. 3.13-4})$$

Table 3.13-1 displays the applicability of Eq. 3.13-4 in bearing/tear out failures. R2/R1 gives the ratio of predicted load value to the actual. Averaging R2/R1 values it is understood that the model underestimates the load by 2% with a standard deviation of 13% at 0.25 in. of deformation. However, the minimum and the maximum points have to be regarded too. R3/R1 tabulates the ratio between the maximum load and the predicted. It can be seen that the maximum strength of a connection is 14% higher than the predicted strength by the Eq. 3.13-2 with a standard deviation of 8%.

There is not an available strength model for splitting failure so it will be treated as a bearing/tear out failure. In the testing program, it has been observed that splitting failure occurred very close to bearing/tear out. This is justified by Table 3.13-2 which shows the comparison of predicted ultimate load and the actual load value at 0.25 in. of

deformation. Although the R2/R1 ratio has an average value of 0.98, the maximum strength on a bolted connection is, on the average, 6% higher than the predicted value with the current model. So, the bearing/tear out model works well with the splitting failure.

Table 3.13-1 Comparison of Test Load Values with the Predicted Values (B/T)

Test No.	Test Desg.	R1	R2	R3	Δu (in.)	R2/R1	R3/R1	Failure Mode
1	1/4x1/4x3/4	24.38	24.7	28.86	1.07	1.01	1.18	B/T
2	1/4x3/8x3/4	24.38	26.4	29.24	0.6	1.08	1.20	B/T
3	1/4x1/2x3/4	24.38	23.9	27.6	0.61	0.98	1.13	B/T
4	1/4x5/8x3/4	24.38	28.7	30.03	0.7	1.18	1.23	B/T
34	1/4x3/4x7/8	28.96	27.4	28.1	0.48	0.95	0.97	B/T
35	1/4x1x7/8	28.96	27.4	28.86	0.71	0.95	1.00	B/T
46	1/4x1/4x1	33.1	27.5	38.06	1.26	0.83	1.15	B/T
52	3/8x3/8x1	47.7	39.9	52.1	1.48	0.84	1.09	B/T
53	3/8x1/2x1	47.7	44.8	54.1	1.1	0.94	1.13	B/T
66	1/4x1/4x3/4	19.3	19.1	20.8	0.65	0.99	1.08	B/T
67	3/8x3/8x3/4	26.9	25.3	32.2	0.87	0.94	1.20	B/T
68	1/4x1/2x3/4	19.3	23.7	23.8	0.12	1.23	1.23	B/T
70	1/4x5/8x3/4	19.3	22.7	23.7	0.14	1.18	1.23	B/T
72	1/4x1/4x7/8	22.5	22.6	24.6	1.01	1.00	1.09	B/T
73	1/4x5/8x7/8	22.5	27.5	27.5	0.5	1.22	1.22	B/T

Average=	1.02	1.14
Standard Deviation=	0.13	0.08
Maximum=	1.23	1.23
Minimum=	0.76	0.97

R1= Predicted ultimate load at 0.25 in. (kips);

R2= Actual load value at 0.25 in. (kips);

R3= Maximum load value (kips);

Δu = Deformation at the maximum load value (in.).

Table 4.4-2 Comparison Of Test Load Values with Predicted Values (Splitting)

Test No.	Test Desg.	R1	R2	R3	Δ (in.)	R2/R1	R3/R1	Failure Mode
17	1/4x1x3/4	24.38	24.8	27	0.12	1.02	1.11	Splitting
31	1/4x1/4x7/8	28.96	24.9	30.2	1.18	0.86	1.04	Splitting
32	1/4x3/8x7/8	28.96	26.6	27.3	0.7	0.92	0.94	Splitting
33	1/4x1/2x7/8	28.96	28.5	28.7	0.56	0.98	0.99	Splitting
36	3/8x3/8x7/8	41.87	31.9	42.35	1.3	0.76	1.01	Splitting
37	3/8x1/2x7/8	41.87	39.1	42.86	0.85	0.93	1.02	Splitting
38	3/8x3/4x7/8	41.87	35.9	41.1	0.88	0.86	0.98	Splitting
47	1/4x3/8x1	33.1	33.2	33.5	0.44	1.00	1.01	Splitting
48	1/4x1/2x1	33.1	34.9	38.2	0.9	1.05	1.15	Splitting
49	1/4x5/8x1	33.1	34.8	35.4	0.62	1.05	1.07	Splitting
50	1/4x3/4x1	33.1	35.9	37.1	0.13	1.08	1.12	Splitting
51	1/4x1x1	33.1	37.9	37.8	0.8	1.15	1.14	Splitting
54	3/8x5/8x1	47.7	45.3	51.7	0.87	0.95	1.08	Splitting
55	3/8x3/4x1	47.7	45.2	51.7	0.87	0.95	1.08	Splitting
56	3/8x1x1	47.7	45.5	50.5	0.81	0.95	1.06	Splitting
71	1/4x3/4x3/4	19.3	21.6	21.8	0.2	1.12	1.13	Splitting

Average=	0.98	1.06
Standard Deviation=	0.10	0.06
Maximum=	1.15	1.15
Minimum=	0.76	0.94

R1= Predicted ultimate load at 0.25 in. (kips);

R2= Actual load value at 0.25 in. (kips);

R3= Maximum load value (kips);

Δ = Deformation at the maximum load value (in.).

The 1/8-in. combinations are treated differently because of their behavior. All of them except two failed by splitting. The remaining two failed by bearing/tear out. In this specific case, the maximum load point was observed to occur at 0.07 in. of deformation. The strength loss takes place after that. However, it has been observed that the ultimate load at failure is very close to the predicted strength by the analytical model for bearing/tear out. The average ratio between them is 1.01, with a standard deviation of 11% (Table 3.13-3).

Table 3.13-3 Comparison of Test Load Values with Predicted Values (1/8-in. Comb.)

Test No.	Test Design.	Rmax	Rp	Rult	Rult/Rp	Failure Mode
12	1/8x1/8x3/4	13.23	11.63	12.7	1.09	Splitting
13	1/8x1/4x3/4	16	11.49	13.6	1.18	Splitting
14	1/8x3/8x3/4	16.4	11.63	10.5	0.90	Splitting
15	1/8x1/2x3/4	17.1	11.49	12.4	1.08	Splitting
16	1/8x5/8x3/4	15.2	11.63	11.2	0.96	Splitting
26	1/8x1/8x7/8	15.1	14.22	12.8	0.90	Splitting
27	1/8x1/4x7/8	16.6	14.22	14.2	1.00	Splitting
28	1/8x3/8x7/8	18.6	14.22	12.4	0.87	B/T
29	1/8x1/2x7/8	19.1	13.36	13.5	1.01	B/T
30	1/8x3/4x7/8	17	13.41	12.4	0.92	Splitting
65	1/8x1/8x3/4	13.3	8.72	10.1	1.16	Splitting

Average=	1.01
Standard Deviation=	0.11
Maximum=	1.18
Minimum=	0.87

3.13.2.2 Bolt Shear Model

The last of the three failure modes observed in the testing program is the shearing of the bolt. 30 out of 70 tests failed with bolt shear failure. The existing model for the shear strength of a bolt is:

$$R_n = F_v A_b \quad (\text{Eq. 3.13-5})$$

R_n = Nominal design bolt shear strength, (kips);

F_v = Nominal shear strength, (ksi);

A_b = Nominal bolt area, (in²).

The value of F_v shows differences in different editions of the LRFD Manual. In the first edition, the nominal shear strength of an A325 high-strength bolt is tabulated as 72.0 ksi with threads excluded, and 54.0 ksi with threads included in shear plane. The ϕ factor is 0.65. In the second edition of LRFD, these values are modified. The nominal shear strength of an A325 bolt is given as 60 ksi with threads excluded, and 48 ksi with threads included from the shear plane. The ϕ factor is changed to 0.75. This change in ultimate shear strength has been done in order to account for a connection with multiple bolts in which the deformation in the direction of the tensile force is not enough for the bolts to develop a full shearing resistance. This ensures a safer use of bolts. In a single bolt case, it is more realistic to use 72.0 ksi for the ultimate shear strength of a A325 bolt. Comparisons have been made using 72 ksi (Table 3.13-4).

A close examination of Table 3.13-4 shows that the current model with 72.0 ksi underestimates the ultimate shear strength of a bolt by 15% with a relatively low standard deviation, 0.07. The ultimate deformation values range from 0.19 in. to 0.59 in. As an average, the bolts failed at 0.32 in. of deformation.

Table 3.13-4 Comparison of Bolt Shear Test Values with Predicted values

Test No.	Test Desg.	R1	R2	Δu (in.)	R2/R1
7	3/8x3/8x3/4	31.8	36.3	0.53	1.14
6	3/8x1/2x3/4	31.8	36.5	0.51	1.15
9	3/8x5/8x3/4	31.8	37	0.23	1.16
10	3/8x3/4x3/4	31.8	37.53	0.21	1.18
11	3/8x1x3/4	31.8	38.5	0.47	1.21
20	1/2x1/2x3/4	31.8	35.6	0.23	1.12
21	1/2x5/8x3/4	31.8	40	0.25	1.26
22	1/2x1x3/4	31.8	37.4	0.2	1.18
23	5/8x5/8x3/4	31.8	35.3	0.24	1.11
24	5/8x1x3/4	31.8	37.8	0.16	1.19
40	1/2x1/2x7/8	43.29	49.1	0.33	1.13
41	1/2x3/4x7/8	43.29	52.3	0.42	1.21
42	1/2x1x3/4	43.29	52.4	0.32	1.21
43	3/4x3/4x7/8	43.29	49.1	0.27	1.13
44	3/4x1x7/8	43.29	52.8	0.27	1.22
45	1x1x7/8	43.29	53.9	0.2	1.25
57	1/2x1/2x1	56.55	57.4	0.48	1.02
58	1/2x5/8x1	56.55	63.1	0.52	1.12
59	1/2x3/4x1	56.55	63.1	0.38	1.12
60	1/2x1x1	56.55	58.8	0.23	1.04
61	5/8x5/8x1	56.55	56.2	0.19	0.99
62	5/8x3/4x1	56.55	66.1	0.43	1.17
63	5/8x1x1	56.55	60.5	0.25	1.07
64	3/4x3/4x1	56.55	63.1	0.2	1.12
69	1/2x1/2x3/4	31.8	35.7	0.4	1.12
71	5/8x5/8x3/4	31.8	39.6	0.32	1.25

Average=	0.32	1.15
Standard Deviation=	0.12	0.07
Maximum=	0.53	1.26
Minimum=	0.16	0.99

R1= Predicted failure load (kips). $F_v = 72.0$ ksi

R2= Load at failure, (kips)

Δ_u = Deformation at failure (in.).

CHAPTER 4

LOAD vs. DEFORMATION STUDY

4.1 GENERAL

Chapter 4 is devoted to introducing a new load-deformation model and a new approach towards understanding the load-deformation behavior of single bolt, single shear connections.

The need for a new analytical model has been mentioned before, as the old models either do not represent the actual behavior in some cases or are too complicated to implement in generalized relationships. A new analytical model will be introduced so that it can be used easily in generalization study.

One of the major topics included in this thesis is the normalized load-deformation curves approach. The results obtained from this study will be reported and some generalized design curves will be constructed.

4.2 THE KARSU EQUATION

This new analytical model has been designed to represent all the phases that a bolted connection undergoes. It has been observed that the AISC equation does not have

the capability of displaying the behavior of 1/8-in. combinations. They have been observed to lose strength after the yielding point. The reason behind this is thought to be the excessive out of plane deformations taking place in front of the bolt. The Karsu equation can work perfectly with the test data that has this negative slope.

The Karsu equation is a simpler analytical model which can be generalized easily to be applicable for all the cases in the design process. The expression is as follows:

$$R = \Delta \left(\frac{R_o}{K + \Delta} + K_p \right) \quad (\text{Eq. 4.2-1})$$

where

R= Bolt force, kips;

Δ = Deformation, in.;

$R_o = R_{ult}$, Ultimate strength of the connection, kips;

K= Initial slope of the load-deformation curve;

K_p = Slope at the plastic region.

As seen in Eq. 4.2-1, the model has only three parameters to take care of three regions of the load-deformation curve. The simplicity provides a good understanding of the equations working principle. This model is will used in the next part of this chapter.

4.3 NORMALIZED LOAD-DEFORMATION CURVES APPROACH

Since the earliest studies on bolt connections, the problem has been approached from the load-deformation point of view. This approach may be disadvantageous

because it includes a lot of variables that affect the behavior of the connection. These variables are the geometric and material properties of the specimens used. The variations prevent us from investigating the problem on a uniform basis. In order to construct this uniformity, normalization methods are used. Normalization allows the opportunity to eliminate one or several of those variables. From another way of thinking, the question becomes (provided we know the answer to a bit of the problem) is there a uniformity in behavior among the groups of connections that can be used for generalization purposes?

In Chapter 3, the validity of AISC's bearing/tear out and bolt shear strength models have been investigated. The answer was very encouraging that, statistically, the models underestimated the strength by 1% and 10% for bearing/tear out and bolt shear, respectively. In order to use this information, the normalization is based on the test load value (R_{tv}) at a deformation of 0.25 in. for bearing/tear out and 0.16 in. for bolt shear. The bearing deformation of 0.25 in. is considered to be a realistic value by AISC to be used for design purposes in connections. In bolt shear, 0.16 in. was the least deformation at which the failure occurred in any of the tests. The range was 0.16 in. to 0.53 in.

The averaged load-deformation data of 70 tests has been normalized. As the first step to this approach, the normalized curves were investigated separately by their combination groups and bolt sizes. The 1/8-in. combinations with 3/4-in. bolts had almost the same pattern (Fig. 4.3-1), as did 1/8-in. combinations with 7/8-in. bolts (Fig. 4.3-2). The normalized curves went beyond the $R/R_{tv}=1$ line as observed before.

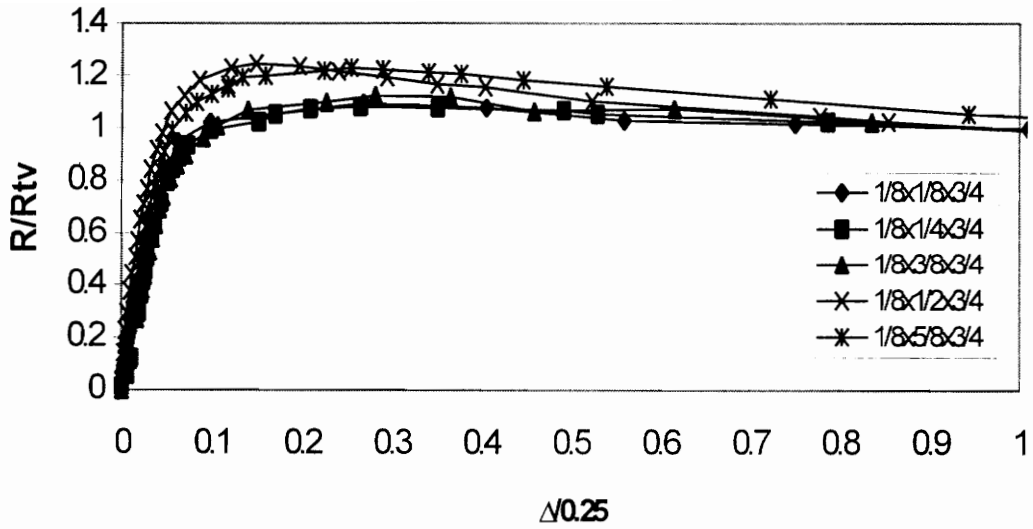

Figure 4.3-1
Normalized 1/8-in. Combinations w/ 3/4-in. Bolt

The 1/4-in. combinations with different bolt sizes had the same trend that the normalized load-deformation curves coincided with each other. The scatter was only at the yielding region, but this diminished with the increasing bolt size (Fig. 4.3-3, Fig. 4.3-4, and Fig 4.3-5).

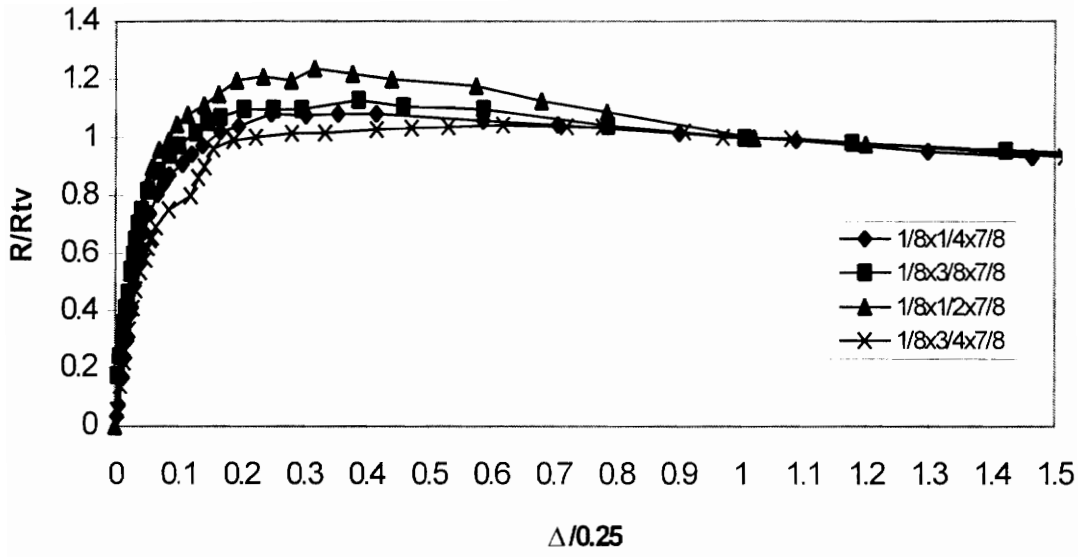

Figure 4.3-2
Normalized 1/8-in. Combinations w/ 7/8-in. Bolt

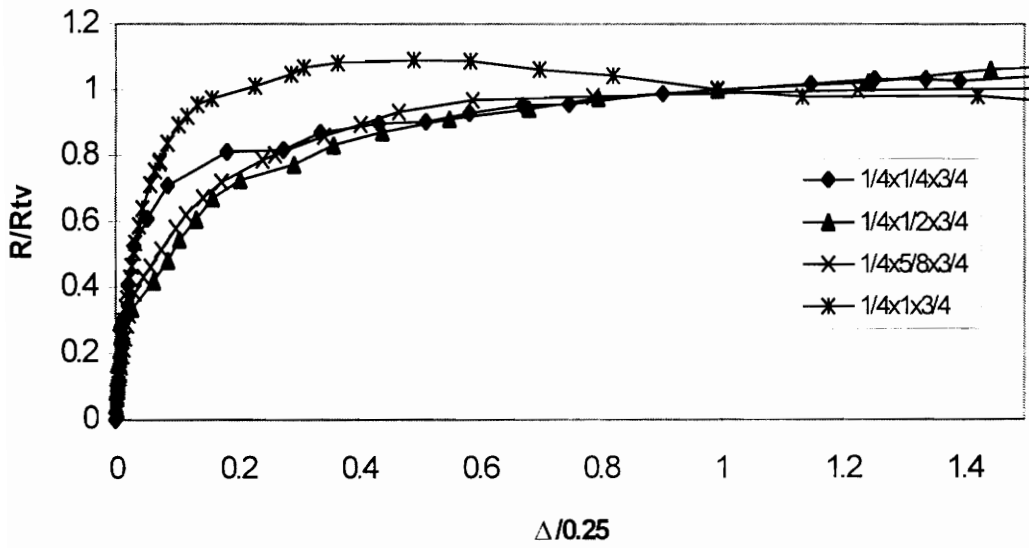

Figure 4.3-3
Normalized 1/4-in. Combinations w/ 3/4-in. Bolt

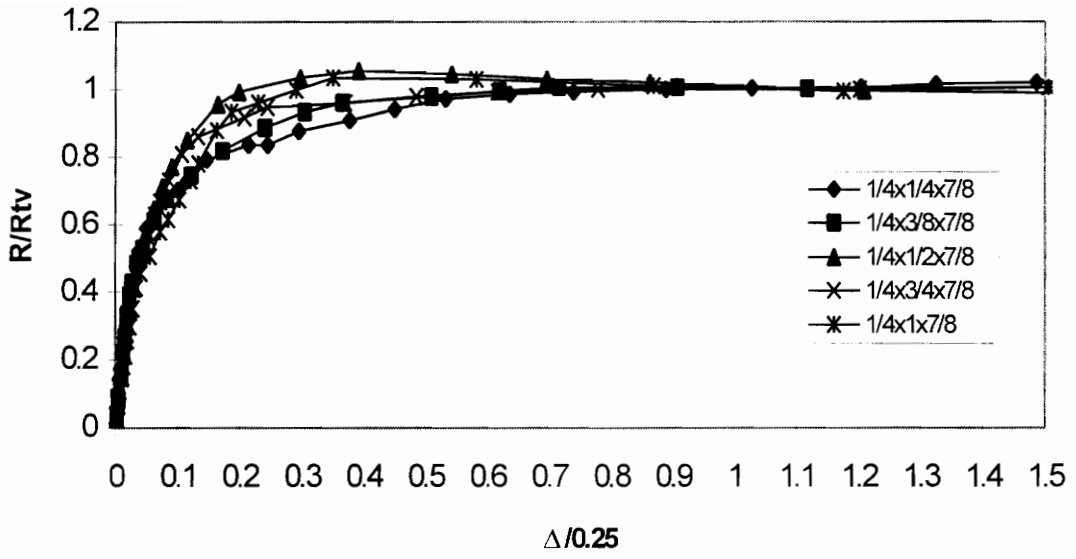

Figure 4.3-4
Normalized 1/4-in. Combinations w/ 7/8-in. Bolt

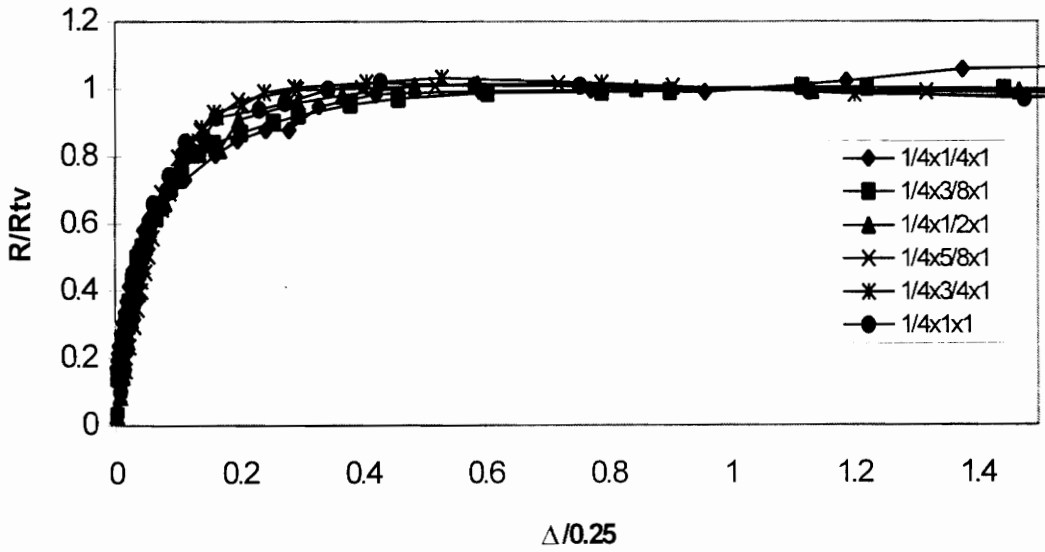

Figure 4.3-5
Normalized 1/4-in. Combinations w/ 1-in. Bolt

As seen in Figures 4.3-6 and 4.3-7, the 3/8-in. combinations with 7/8-in. and 1-in. are so tight that they can be represented with one curve.

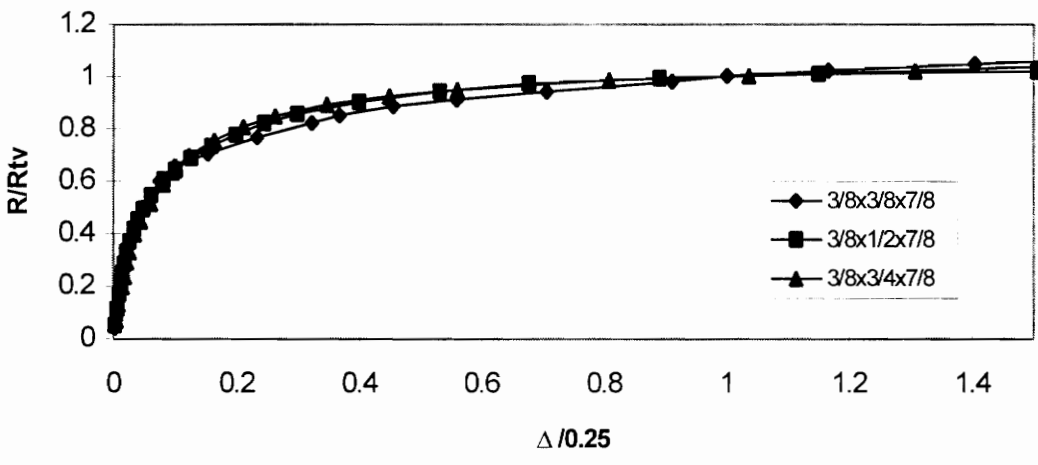

Figure 4.3-6
Normalized 3/8-in. Combinations w/ 7/8-in. Bolt

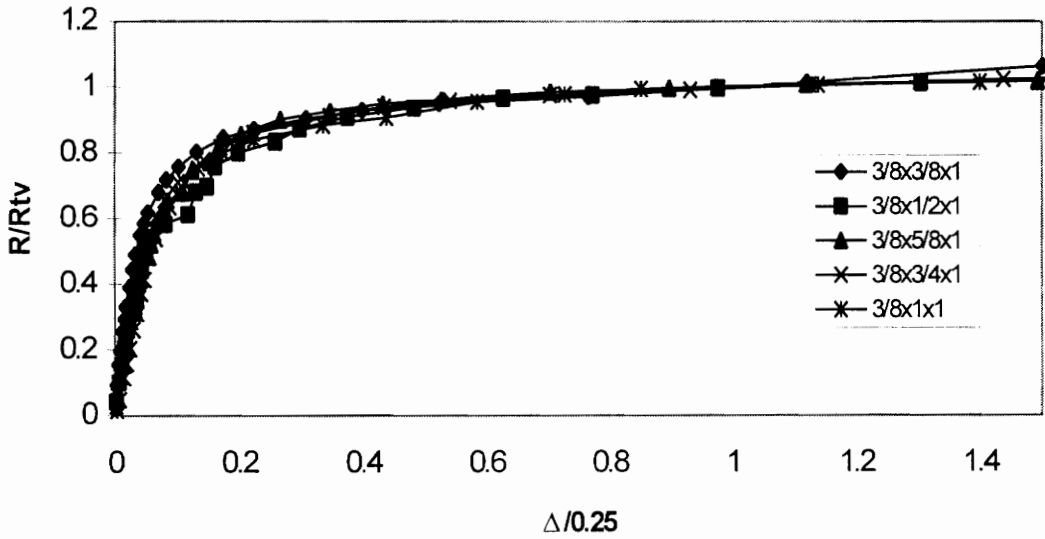

Figure 4.3-7
Normalized 3/8-in. Combinations w/ 1-in. Bolt

Preliminary investigations on normalized bolt shear load-deformation curves show that all of the individual curves are very tight, so they can be represented by one, simplified curve (Figure 4.3-8).

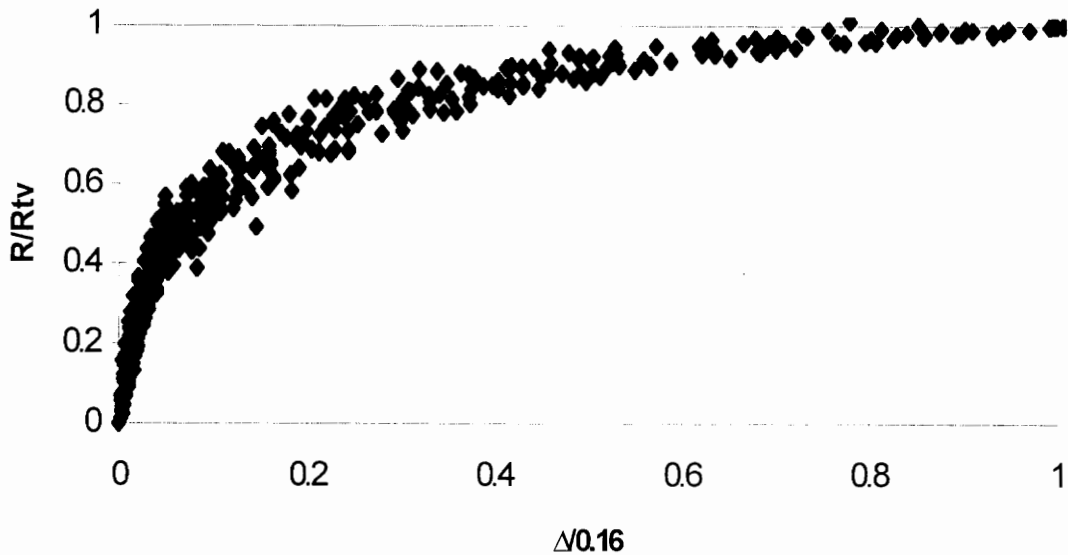

Figure 4.3-8
Normalized Bolt Shear Tests

Another question concerns the behavior of the tests with edge distance 1.5 times the bolt diameter and their difference from the $2.0d_b$ tests. It has been found that when normalized, the only difference is in the yielding region. The $1.5d_b$ tests remain stiff up to the plastic region where $2.0d_b$ tests soften at early stages (Figure 4.3-9). In the first part of the elastic region and plastic region the behavior is exactly the same. Both 1/8-in. combinations with 3/4-in. bolts give the same response (Figure 4.3-10).

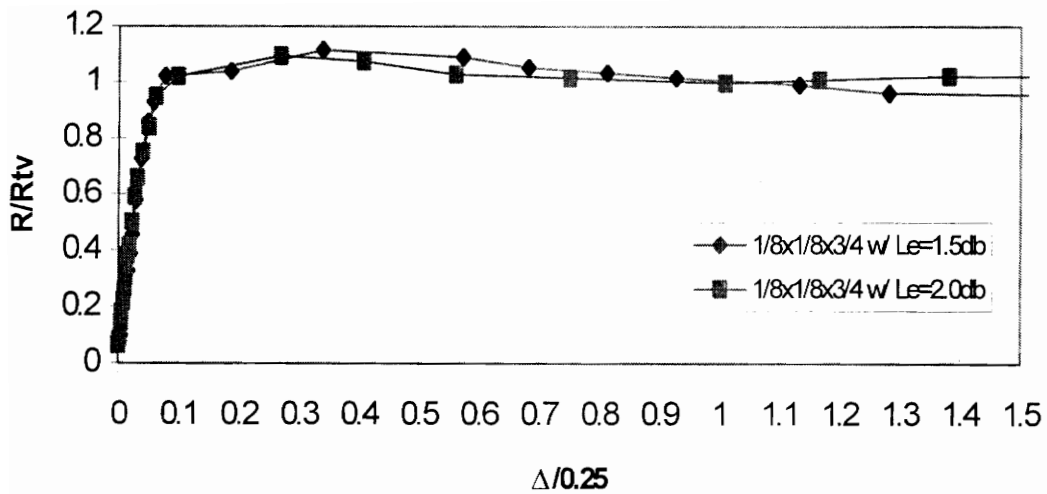

Figure 4.3-9
Comparison of 1.5 d_b and 2.0 d_b Tests

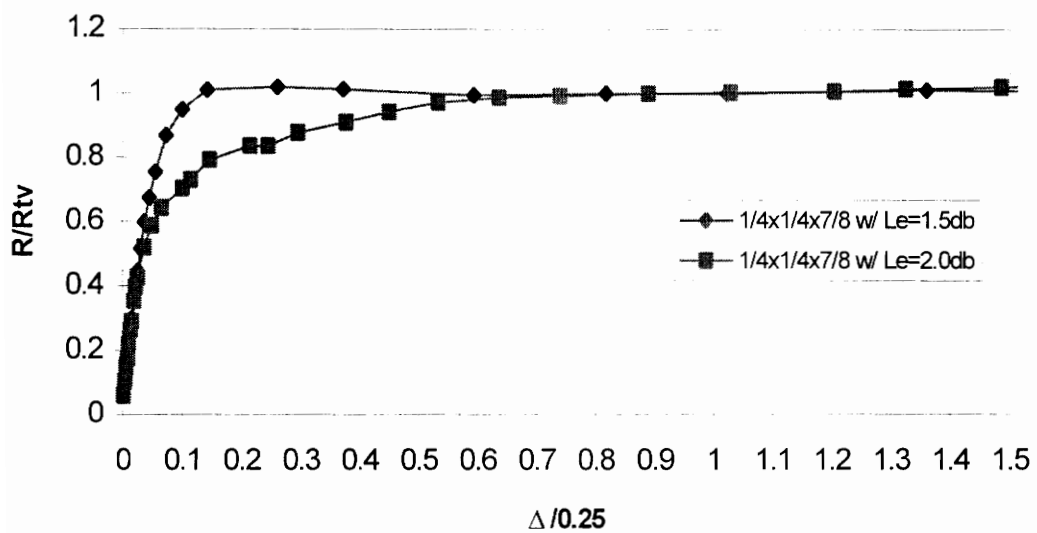

Figure 4.3-10
Comparison of 1.5 d_b and 2.0 d_b Tests

4.3.1 The Analytical Models

Three analytical models, AISC's, Richard's, and Karsu's, were fitted to the normalized load-deformation data for each test. The equations become as follows when normalized:

AISC:

$$\frac{R}{R_{iv}} = (1 - e^{-\mu \frac{\Delta}{0.25}}) \quad (\text{Eq. 4.3-1})$$

Richard's:

$$\frac{R}{R_{iv}} = \frac{K_1 \frac{\Delta}{0.25}}{\left[1 + \left| \frac{K_1 \frac{\Delta}{0.25}}{R_0} \right|^n \right]^{\frac{1}{n}}} + K_p \frac{\Delta}{0.25} \quad (\text{Eq. 4.3-2})$$

Karsu's:

$$\frac{R}{R_{iv}} = \frac{\Delta}{0.25} \left(\frac{R_0}{K + \frac{\Delta}{0.25}} + K_p \right) \quad (\text{Eq. 4.3-3})$$

Where bolt shear is concerned, 0.25 should be switched with 0.16 as bolt shear tests were normalized by 0.16 in. of deformation..

Tables 4.3-1, 4.3-2, and 4.3-3 tabulate the parameters of AISC, Karsu, and Richard models, respectively, for each test included in the testing program.

Table 4.3-1, AISC Model Parameters

Test Designation	R	μ	λ
1/4x1/4x3/4	1.0	-16.21	0.738
1/4x3/8x3/4	1.0	-7.11	0.495
1/4x1/2x3/4	1.0	-1.95	0.382
1/4x5/8x3/4	1.0	-4.84	0.551
1/4x1x3/4	1.0	-17.44	0.84
1/8x1/8x3/4	1.0	-34.07	1.108
1/8x1/4x3/4	1.0	-40.36	2
1/8x3/8x3/4	1.0	-34.64	1.71
1/8x1/2x3/4	1.0	-39.69	948
1/8x5/8x3/4	1.0	-37.91	1.357
3/8x3/8x3/4	1.0	-5.03	0.564
3/8x1/2x3/4	1.0	-5.81	0.556
3/8x5/8x3/4	1.0	-1.67	0.501
3/8x1x3/4	1.0	-6.09	0.617
1/2x1/2x3/4	1.0	-5.68	0.537
1/2x5/8x3/4	1.0	-4.72	0.556
1/2x1x3/4	1.0	-2.81	0.504
5/8x5/8x3/4	1.0	-2.54	0.488
5/8x1x3/4	1.0	-3.02	0.45
1x1x3/4	1.0	-3.05	0.51
1/8x1/8x7/8	1.0	25.23	1.11
1/8x1/4x7/8	1.0	-24.92	1.25
1/8x3/8x7/8	1.0	-23.26	0.827
1/8x1/2x7/8	1.0	-21.81	0.836
1/8x3/4x7/8	1.0	-15.02	0.859
1/4x1/4x7/8	1.0	-8.75	0.569
1/4x3/8x7/8	1.0	-10.3	0.672
1/4x1/2x7/8	1.0	-15.38	0.956
1/4x3/4x7/8	1.0	-16.36	1.024
1/4x1x7/8	1.0	-8.8	0.715
3/8x3/8x7/8	1.0	-61.63	0.532
3/8x1/2x7/8	1.0	-5.96	0.535
3/8x3/4x7/8	1.0	-7.24	0.639
1/2x1/2x7/8	1.0	-4.42	0.514
1/2x3/4x7/8	1.0	-3.92	0.554
1/2x1x3/4	1.0	-3.28	0.558
3/4x3/4x7/8	1.0	-2.96	0.362
3/4x1x7/8	1.0	-2.09	0.425
1x1x7/8	1.0	-3.26	0.464
1/4x1/4x1	1.0	-6.28	0.433
1/4x3/8x1	1.0	-9.08	0.582
1/4x1/2x1	1.0	-13.38	0.939
1/4x5/8x1	1.0	-15.9	1.13
1/4x3/4x1	1.0	-15.56	1.26
1/4x1x1	1.0	-16.36	1.024

Table 4.3-1, AISC Model Parameters (Continued)

Test Designation	R	μ	λ
3/8x3/8x1	1.0	-12.69	0.647
3/8x1/2x1	1.0	-6.52	0.623
3/8x5/8x1	1.0	-9.03	0.701
3/8x3/4x1	1.0	-13	0.935
3/8x1x1	1.0	-13.36	1.15
1/2x1/2x1	1.0	-4.42	0.56
1/2x5/8x1	1.0	-5.07	0.587
1/2x3/4x1	1.0	-3.36	0.548
1/2x1x1	1.0	-4.62	0.639
5/8x5/8x1	1.0	-4.25	0.631
5/8x1x1	1.0	4.138	0.628
3/4x3/4x1	1.0	-2.74	0.595
1/8x1/8x3/4	1.0	-38.83	1.447
1/4x1/4x3/4	1.0	-38.85	1.432
3/8x3/8x3/4	1.0	-7.59	0.504
1/4x1/2x3/4	1.0	-14.82	1
1/2x1/2x3/4	1.0	-7.32	0.622
1/4x5/8x3/4	1.0	-16.54	1.306
5/8x5/8x3/4	1.0	-7.96	0.655
1/4x3/4x3/4	1.0	-37.4	2.19
1/4x1/4x7/8	1.0	-26.24	1.109
1/4x5/8x7/8	1.0	25.36	1.024

Table 4.3-2, Karsu Model Parameters

Test Designation	R	K	Kp
1/4x1/4x3/4	0.897	0.0269	0.121
1/4x3/8x3/4	0.793	0.0221	0.239
1/4x1/2x3/4	0.617	0.0151	0.478
1/4x5/8x3/4	0.857	0.0857	0.004
1/4x1x3/4	1.334	0.0484	-0.271
1/8x1/8x3/4	1.4	0.0361	-0.408
1/8x1/4x3/4	1.476	0.05	-0.465
1/8x3/8x3/4	1.53	0.053	-0.508
1/8x1/2x3/4	1.506	0.0247	-0.528
1/8x5/8x3/4	1.61	0.038	-0.573
3/8x3/8x3/4	0.877	0.0509	0.169
3/8x1/2x3/4	0.964	0.0444	0.079
3/8x5/8x3/4	0.9	0.0917	0.137
3/8x1x3/4	0.936	0.0562	0.118
1/2x1/2x3/4	0.884	0.0402	0.174
1/2x5/8x3/4	0.87	0.0513	0.183
1/2x1x3/4	0.786	0.0557	0.275
5/8x5/8x3/4	0.761	0.0521	0.3
5/8x1x3/4	0.81	0.0402	0.283
1x1x3/4	0.85	0.409	0.311
1/8x1/8x7/8	1.444	0.556	-0.425
1/8x1/4x7/8	1.458	0.0573	-0.411
1/8x3/8x7/8	1.359	0.0349	-0.32
1/8x1/2x7/8	1.554	0.0416	-0.486
1/8x3/4x7/8	1.316	0.0576	-0.249
1/4x1/4x7/8	0.951	0.0337	0.099
1/4x3/8x7/8	1.063	0.0454	-0.0048
1/4x1/2x7/8	1.426	0.0714	-0.35
1/4x3/4x7/8	1.29	0.0677	-0.242
1/4x1x7/8	1.341	0.0807	-0.239
3/8x3/8x7/8	0.845	0.0338	0.188
3/8x1/2x7/8	0.912	0.0413	0.144
3/8x3/4x7/8	1.023	0.0581	0.0394
1/2x1/2x7/8	0.88	0.0483	0.175
1/2x3/4x7/8	0.907	0.0692	0.159
1/2x1x7/8	0.845	0.066	0.235
3/4x3/4x7/8	0.739	0.0212	0.29
3/4x1x7/8	0.707	0.0368	0.353
1x1x7/8	0.759	0.0349	0.311
1/4x1/4x1	0.922	0.0259	0.13
1/4x3/8x1	1.042	0.0407	0.005
1/4x1/2x1	1.292	0.0738	-0.216
1/4x5/8x1	1.455	0.0864	-0.368
1/4x3/4x1	1.609	0.108	-0.489
1/4x1x1	1.29	0.0667	-0.241
3/8x3/8x1	1.006	0.0347	0.0196
3/8x1/2x1	1.006	0.0601	0.063

Test Designation	R	K	Kp
3/8x5/8x1	1.101	0.0611	-0.048
3/8x3/4x1	1.169	0.069	-0.111
3/8x1x1	1.266	0.0947	-0.185
1/2x1/2x1	0.899	0.0596	0.157
1/2x5/8x1	0.942	0.0629	0.125
1/2x3/4x1	0.802	0.0571	0.257
1/2x1x1	1.004	0.0861	0.087
5/8x5/8x1	0.951	0.0802	0.155
5/8x1x1	0.912	0.0796	0.164
3/4x3/4x1	0.777	0.0739	0.303
1/8x1/8x3/4	1.467	0.0416	-0.44
1/4x1/4x3/4	1.151	0.387	-0.13
3/8x3/8x3/4	0.939	0.0311	0.119
1/4x1/2x3/4	1.248	0.0699	-0.181
1/2x1/2x3/4	0.924	0.0461	0.124
1/4x5/8x3/4	1.557	0.1	-0.123
5/8x5/8x3/4	0.987	0.0501	0.067
1/4x3/4x3/4	1.387	0.0567	-0.359
1/4x1/4x7/8	1.33	0.0446	-0.316
1/4x5/8x7/8	1.31	0.451	-0.325

Table 4.3-3, Richard's Model Parameters

Test Designation	R	K	Kp	n
1/4x1/4x3/4	0.798	24.6	0.216	1.56
1/4x3/8x3/4	0.881	43.32	0.169	0.819
1/4x1/2x3/4	0.758	35.66	0.175	0.75
1/4x5/8x3/4	1.9	48.12	-0.177	0.446
1/4x1x3/4	12.7	25.36	-0.219	1.106
1/8x1/8x3/4	1.146	26.53	-0.161	1.915
1/8x1/4x3/4	1.071	17.34	-0.066	3.45
1/8x3/8x3/4	1.15	17.81	-0.144	2.57
1/8x1/2x3/4	1.354	43.24	-0.383	1.49
1/8x5/8x3/4	1.317	26.95	-0.29	1.95
3/8x3/8x3/4	0.915	18.53	0.141	0.923
3/8x1/2x3/4	0.883	18.04	0.117	1.31
3/8x5/8x3/4	0.913	19.51	0.101	1.25
3/8x1x3/4	0.985	17.87	0.0867	0.921
1/2x1/2x3/4	1.339	38.98	-0.0649	0.578
1/2x5/8x3/4	1.055	21.84	-0.0717	0.754
1/2x1x3/4	2.65	61.1	-0.14	0.344
5/8x5/8x3/4	9.26	260.2	-0.316	0.207
5/8x1x3/4	8.3	589.9	-0.345	0.198
1x1x3/4	8.61	150.5	-0.334	0.205
1/8x1/8x7/8	1.15	19.25	-0.275	1.75
1/8x1/4x7/8	1.13	17.61	-0.121	1.89
1/8x3/8x7/8	1.279	34	-0.252	1.16
1/8x1/2x7/8	1.554	36.86	-0.486	1
1/8x3/4x7/8	1.182	19.18	-0.149	1.25
1/4x1/4x7/8	0.936	27.49	0.118	1.04
1/4x3/8x7/8	1.036	22.55	0.015	1.05
1/4x1/2x7/8	1.219	16.47	-0.195	1.33
1/4x3/4x7/8	0.988	13.7	0.018	1.85
1/4x1x7/8	2.868	31.49	-0.749	0.51
3/8x3/8x7/8	0.833	24.49	0.197	1.034
3/8x1/2x7/8	1.092	29.2	0.029	0.747
3/8x3/4x7/8	1.079	18.88	0.004	0.917
1/2x1/2x7/8	1.04	23.19	0.077	0.77
1/2x3/4x7/8	1.197	18.22	0.013	0.701
1/2x1x3/4	1.39	20.74	-0.0015	0.586
3/4x3/4x7/8	0.941	68.91	0.169	0.604
3/4x1x7/8	1.096	41.54	0.161	0.535
1x1x7/8	2.21	104.7	-0.109	0.343
1/4x1/4x1	2.99	425	-0.363	0.28
1/4x3/8x1	1.244	34.83	-0.119	0.738
1/4x1/2x1	1.04	13.63	-0.016	1.52
1/4x5/8x1	1.054	11.62	-0.048	2.04
1/4x3/4x1	1.071	10.02	-0.064	2.26
1/4x1x1	0.988	13.7	0.018	1.85
3/8x3/8x1	0.976	27.29	0.044	1.07
3/8x1/2x1	1.134	19.1	-0.019	0.845

Test Designation	R	K	Kp	n
3/8x5/8x1	1.092	17.75	-0.036	1.015
3/8x3/4x1	0.884	11.91	0.127	1.98
3/8x1x1	0.827	8.85	0.191	2.77
1/2x1/2x1	0.825	13.56	0.21	1.18
1/2x5/8x1	1.247	20.88	-0.034	0.697
1/2x3/4x1	0.711	12.24	0.328	1.285
1/2x1x1	1.307	14.77	-0.06	0.74
5/8x5/8x1	1.25	14.5	-0.065	0.81
5/8x1x1	1.026	13.01	0.099	0.856
3/4x3/4x1	2.11	21.71	-0.089	0.454
1/8x1/8x3/4	1.115	20.88	-0.098	3.22
1/4x1/4x3/4	0.899	20.08	0.119	3.29
3/8x3/8x3/4	1.04	37.3	0.044	0.813
1/4x1/2x3/4	0.97	13.12	0.0494	1.78
1/2x1/2x3/4	1.288	29.17	-0.084	0.641
1/4x5/8x3/4	1.079	10.58	-0.047	2.24
5/8x5/8x3/4	0.981	19.6	0.0717	1.01
1/4x3/4x3/4	0.969	13.71	0.0443	6.49
1/4x1/4x7/8	1.058	19.19	-0.0687	2.14
1/4x5/8x7/8	1.12	17.85	0.0054	1.89

4.4 UNIFIED DESIGN CURVES

Unification of the test data in order to get single design curve has been performed with bolt shear tests because of their similar nature when normalized. It is proposed that applying the same approach to the bearing/tear-out failure normalized data produces a simplified and acceptably accurate method for the determination of ultimate strength of bolted connections.

Figures 4.4-1, 4.4-2, and 4.4-3 show merged data points of 1/8-in., 1/4-in., and 3/8-in., respectively, regardless of the bolt size used.

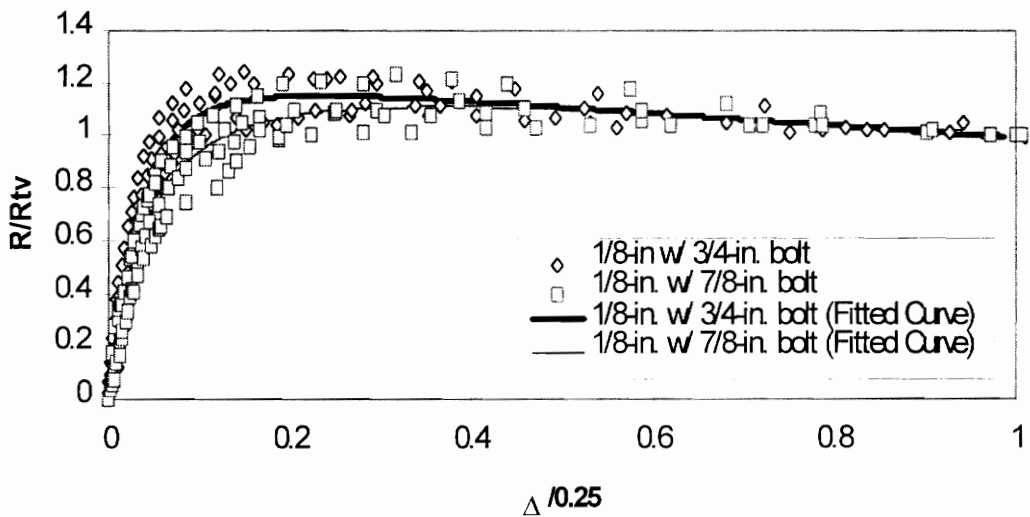

Figure 4.4-1
1/8-in. Combinations Normalized Data

As seen in Figure 4.4-1, the bolt size decreases the hump which is formed in the yielding region, however, the behavior is just the same before and after this part of the normalized curve. On the other hand, it can be concluded that a single curve can represent the two behaviors. A curve fitting study has been conducted for the determination of the parameters of the three load-deformation models. Figure 4.4-2 shows the unified design curves plotted over data points. The AISC's model is too insufficient to display the actual behavior as mentioned before and the curves for Richard's and Karsu's model may not be distinguished, as they coincided.

Table 4.4-1 tabulates the unified design curve parameters for each of the analytical load-deformation model used.

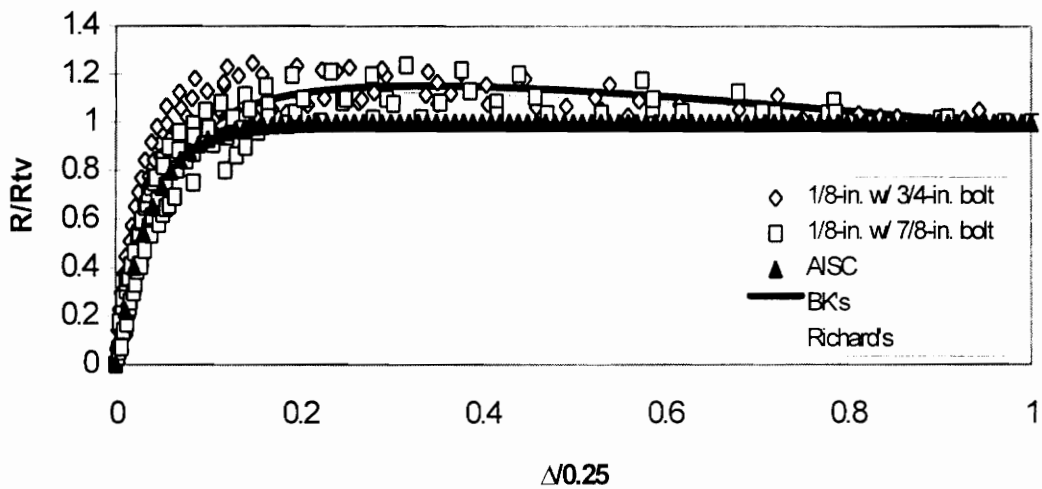

Figure 4.4-2
Unified Design Curves for 1/8-in. Combinations

Table 4.4-1 Parameters of Load-deformation Models for Unified Design Curve of 1/8-in. Combinations

AISC:	$R = 1.0$	$\mu = -27.16$	$\lambda = 1.04$	
Karsu:	$R = 1.45$	$K = 0.0413$	$K_p = -0.414$	
Richard:	$R = 1.234$	$K = 25.42$	$K_p = -0.226$	$n = 1.56$

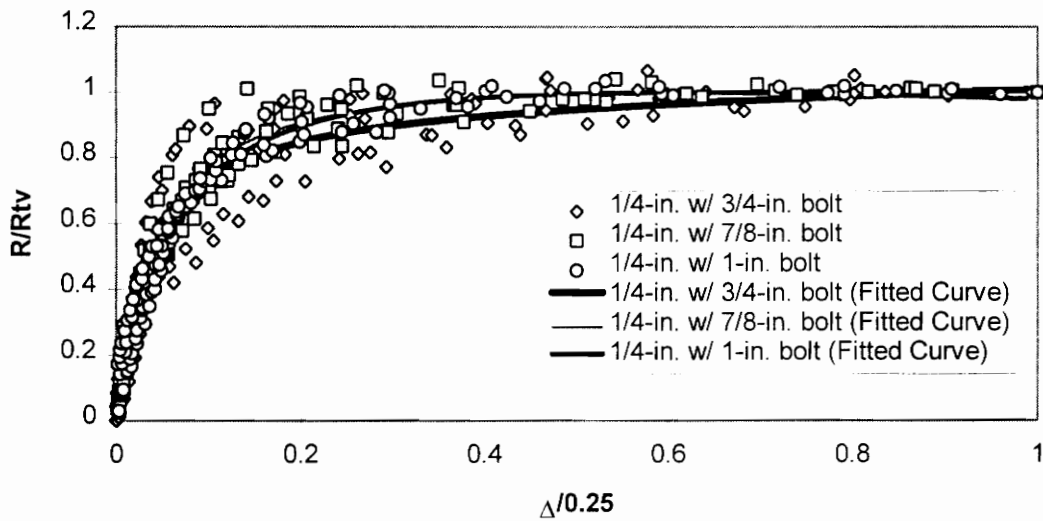

Figure 4.4-3
1/4-in. Combinations Normalized Data

The 1/4-in. combinations show similarities with the 1/8-in. combinations. As seen in Figure 4.4-3, the data points are tight enough to be represented by a single curve. Figure 4.4-4 shows the unified design curves for 1/4-in. combinations plotted on data. The parameters for the models are tabulated in Table 4.4-2.

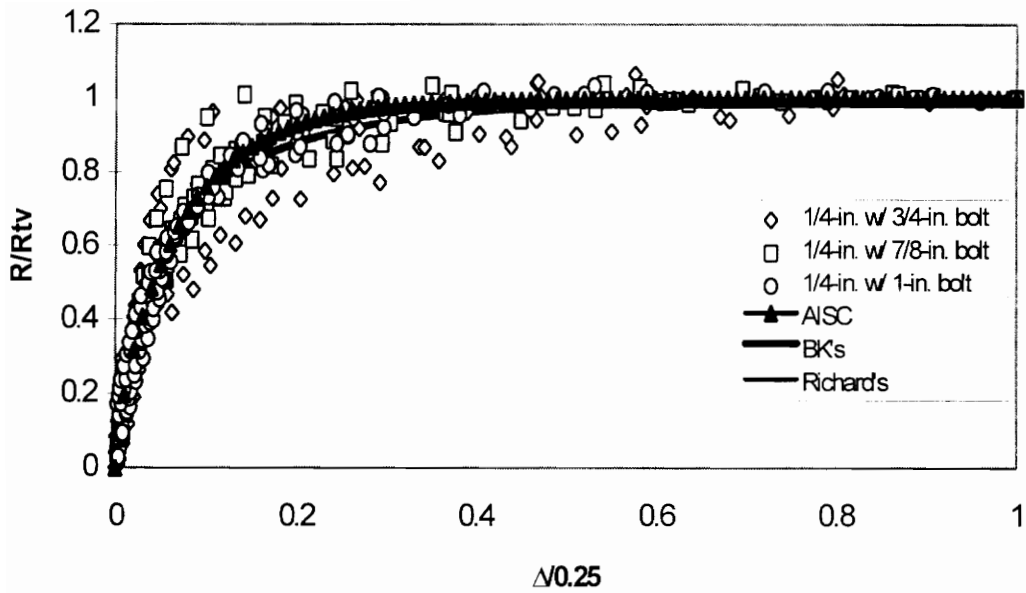

Figure 4.4-4
 Unified Design Curves for 1/4-in. Combinations

Table 4.4-2 Parameters of Load-deformation Models
 for Unified Design Curve of 1/4-in. Combinations

AISC:	$R = 1.0$	$\mu = -11.73$	$\lambda = 0.736$
Karsu:	$R = 1.12$	$K = 0.0509$	$K_p = 0.0712$
Richard:	$R = 1.07$	$K = 20.34$	$K_p = -0.0286$ $n = 1.11$

The 3/8-in. combinations provide even better results for unified design curves as they had closer data points than the other combinations. The design curves that have been constructed have higher accuracy. As it be observed in Figure 4.4-5, the level of the hump decreases with increasing plate thickness. Figure 4.4-6 gives the unified design curves for 3/8-in. combinations. Table 4.4-3 tabulates the unified design curve parameters for the available analytical models.

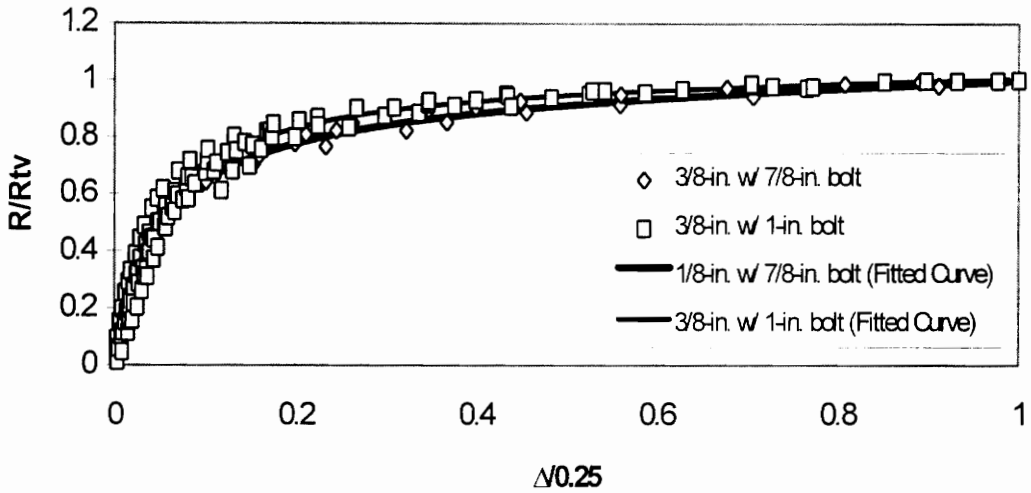

Figure 4.4-5
3/8-in. Combinations Normalized Data

Table 4.4-3 Parameters of Load-deformation Models
for Unified Design Curve of 3/8-in. Combinations

AISC:	$R= 1.0$	$\mu= -8.184$	$\lambda= 0.636$	
Karsu:	$R= 1.01$	$K= 0.0508$	$K_p= 0.0423$	
Richard:	$R= 1.02$	$K= 20.14$	$K_p= 0.0368$	$n= 1.11$

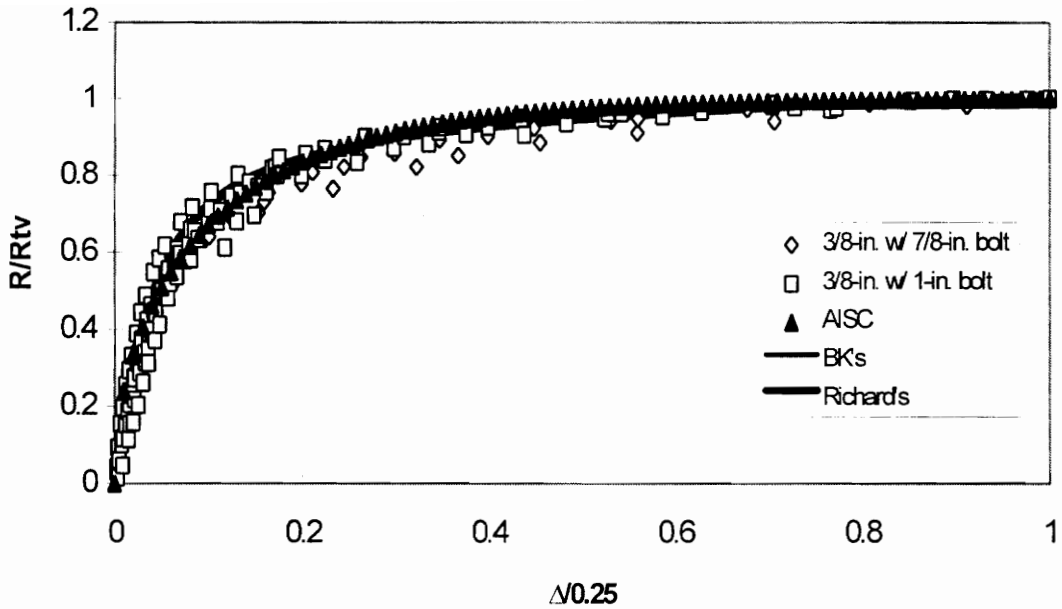

Figure 4.4-6
 Unified Design Curves for 3/8-in. Combinations

For the bolt shear case, there is only one curve for all of the plate and bolt sizes. Figure 4.3-8 shows the overall normalized data points of bolt shear tests. It is obvious that one curve can accurately represent the whole data. Table 4.4-4 tabulates the parameter values for the analytical models used.

Table 4.4-4 Parameters of Load-deformation Models
for Unified Design Curve of Bolt Shear Failure

AISC:	R= 1.0	$\mu = -3.0$	$\lambda = 0.47$	
Karsu:	R= 0.84	K= 0.043	$K_p = 0.022$	
Richard:	R= 1.13	K= 26.3	$K_p = 0.061$	n= 0.66

The Unified Design Curves approach utilizes the information on the accuracy of AISC strength model in predicting the ultimate strength which has been revealed in Chapter 3. It has been shown that the available model underestimates the bearing strength of a connection at a deformation of 0.25 in. by 1% on the average. Therefore, R_{tv} can be assumed to be equal to ultimate bearing strength of a single bolt connection predicted by the AISC model. In the case of bolt shear, R_{tv} becomes the shearing strength of the fastener.

The designer should note that instead of using the generalized parameters, he can use the actual parameters which have been tabulated in Figure 4.3-9 for the tests covered in this project. It is strongly believed that a unified approach can provide a good and simple method to determine the load-deformation model of a bolted connection.

Author's Note: The plots of AISC, Karsu, and Richard models that have been included in Figures 4.4-2, 4.4-4, and 4.4-6 use the parameters that were obtained from the curve fitting study, not the parameters reported by original authors. These modified parameters are tabulated in Tables 4.4-1, 4.4-2, and 4.4-3.

CHAPTER 5

SUMMARY, CONCLUSIONS AND RECOMMENDATIONS

5.1 SUMMARY

Advancements in design methods and construction techniques are resulting in requirements for a better and more detailed understanding of the responses of the materials used. Bolted connections, being one of the basic parts of steel construction, deserve intense study on their behavior because of its important role in "Partially Restrained Connections."

The goal of this study was to reach an understanding of the load-deformation behavior of bolted connections and develop a generalized physical model to be used in all cases. In order to accomplish these goals an experimental study which includes 70 single bolt, single shear tension tests was conducted. The test matrix was designed to take into account different aspects of the actual behavior of bolted connections. The results obtained from the tests were compared with AISC provisions and Richard's work. AISC's method was proven to be accurate in predicting the failure load and mode well; however, the expression used was unable to reflect the actual load-deformation response. Richard's formula worked fine when compared with our test data, but the nongeneralized

parameters were not useful for applying the expression to extensive cases. The formula with reported parameters did not display the behavior observed in our testing program when the failure mode is bolt shear.

Another approach towards understanding the actual behavior of bolted connections has been introduced-- the load-deformation curves have been normalized so that the results of the tests could be compared on a uniform basis. The normalization was performed based on the test load value at 0.25 in. and 0.16 in. of deformation, for bearing/tear out and bolt shear failures, respectively. The results of the study were so consistent that the Unified Design Curve Method has been proposed. For bolt shear, one curve has been proven to be capable of representing the general behavior. Also, for the bearing/tear out and splitting failures, one unified design curve for each combination has been constructed. Obviously, these unified curves may not give exact values, but they are shown to be sufficiently accurate for design purposes. The new Karsu load-deformation model has been introduced as an alternative to the AISC and Richard's models. This model is more convenient for use with less and independent parameters. The parameters of the three models for each test have been tabulated in tables so they can be used instead of the unified design curves.

5.2 CONCLUSIONS

The following conclusions have been reached as a result of the study:

1. The load-deformation behavior of the bolted connection is determined by the controlling mode of failure. Three kinds of failure modes were observed: 1) bearing/tear-out, 2) splitting of the plate at the edge, 3) shearing of the bolt. Splitting at the edge of the plate was observed to be more critical than bearing/tear out. It has been seen that they both occur at almost the same time but failure by splitting develops faster; therefore they are assumed to be sharing the same ultimate strength.
2. The load-deformation behavior of the bolted connection is mostly dependent on the thinner of the connected plates; however it is definite that the thicker plate has an effect on the load-deformation curve in a way that the elastic region is prolonged and the plastic slope is decreased, but these effects were not found to be very consistent throughout the whole testing program. Generalization is yet to be done at this stage of the study.
3. The load-deformation response of the bolted connections was not consistent. Random behaviors which prevent generalization were observed in the testing program.
4. Pretensioning the bolts provided stiffness to the connection
5. The bearing strength of a single bolt connection can be predicted accurately with the AISC formula:

$$R_n = L_e F_u t$$

For bolt shear, the shearing strength of a A325 bolt was found to be more 72 ksi which AISC recommends to use. However, it is also noted that in most of the bolt shear cases

bending of the bolt because of the eccentricity on the connection was involved. Therefore 72 ksi seems to be a safer value to use.

6. Normalization based on test load values at 0.25 in. of deformation provided good results for generalization purposes. Grouping has been observed among the combinations. That has been used to construct unified design curves.

7. The behavior of a bolted connection can be represented by a single curve when the controlling mode of failure is bolt shear. A unified design curve has been constructed to predict the load-deformation response of a given connection.

8. For the test load value (R_{IV}), the predicted load value can be used for design purposes.

9. Any of the three analytical models can be used to predict the load-deformation behavior of the bolted connections. The parameters have been tabulated in tables for unified design curves. Also, the parameters

for individual tests have been reported so that one can use these values for more accuracy.

5.3 RECOMMENDATIONS

Based on the experimental data and analytical investigation, the following recommendations are made for future work in this subject:

1. The material properties of the bolts have to be determined. In the experimental study, the shear strength of an A325 bolt was found to be more than 72 ksi which is recommended by AISC.
2. The effect of the A490 bolt type on the load-deformation response of bolted connection has to be determined.
3. The effect of steel grade should also be determined. Grade 50 steel plates should be used in the test program. Also, combinations of A36 and Grade 50 steel have to be tested.
4. It needs to be determined if the resistance provided by two plates bolted together with three bolts is three times the resistance of those bolted together with one bolt.
5. Further formulation of the proposed physical model has to be made.
6. The Unified Design Curves have been based on only one set of data that has been performed at Virginia Polytechnic Institute and State University; for a better understanding of the behavior of bolted connections a more extensive testing program has to be done.

REFERENCES

- Crawford, S.F., and Kulak, G.L. (1971). "Eccentrically Loaded Bolted Connections," *ASCE Journal of the Structural Division* March, 1971, 97(ST3), 765-783
- Fisher, J.W. (1965). "Behavior of Fasteners and Plates with Holes," *ASCE Journal of the Structural Division*, 91(ST6), 265-286
- Francis, A.J. (1953). "The Behavior of Aluminum Alloy Riveted Joints," Research Report No. 15, The Aluminum Development Assn., London, England
- Kulak, G.L., Fisher, J.W., and Struik, J.H.A. (1987).
Guide to Design Criteria for Bolted Connections and Riveted Joints, John Wiley and Sons
- Load and Resistance Factor Design Specification for Structural Steel Buildings* (1986). American Institute of Steel Construction, Chicago, Illinois
- Load and Resistance Factor Design Specification for Structural Steel Buildings* (1994). American Institute of Steel Construction, Chicago, Illinois
- Manual of Steel Construction ASD/LRFD Volume II Connections* (1992). American Institute of Steel Construction, Chicago, Illinois
- Manual of Steel Construction LRFD Volume II Connections* (1994). American Institute of Steel Construction, Chicago, Illinois
- Richard, R.M., Gillett, P.E., Kriegh, D.J., and Lewis, B.A. (1980). "The Analysis and Design of Single Plate Framing Connections," *AISC Engineering Journal*, 2nd Qtr. 1980 38-52
- Rumpf, J.L. (1960). "The Ultimate Strength of Bolted Connections," thesis presented to Lehigh University, at Bethlehem, PA, in 1960, in partial fulfillment of the requirements for the degree of Doctor of Philosophy
- Salmon, C.G. and Johnson, J.E. (1990). *Steel Structures: Design and Behavior*, Third Edition, Harper and Row, New York
- Specification for Structural Steel Buildings Allowable Stress Design and Plastic Design* (1989). American Institute of Steel Construction, Chicago, Illinois
- Tate, M.B., and Rosenfeld, S.J. (1946). "Preliminary Investigation of the Loads Carried by Individual Bolts in Bolted Joints," Technical Note No. 1051, Natl. Advisory Comm. for Aeronautics, Washington, D.C., 1946

NOMENCLATURE

α = curve fitting parameter

β = curve fitting parameter

Δ = deformation of a connection

τ = regression coefficient

λ = regression coefficient

μ = regression coefficient

ε = strain in the coupon

σ = stress in the coupon

σ_b = tension strength of the bolt

Δ_u = deformation at maximum load

ε_u = strain at rupture

σ_u = ultimate tensile strength of the coupon

τ_u^p = shear strength of the plate

σ_u^p = tension strength of the plate

ε_y = yield strain

σ_y = yielding point of the coupon

A_b = area of the fastener

A_b^N = area of the fastener when threads are included in the shear plane

A_b^X = area of the fastener when threads are excluded from the shear plane

A_g = gross area of the coupon

A_n = nominal area of the plate

D = bolt diameter

d = diameter of the bolt

d = diameter of the fastener

D_b = deformation of bending

d_b = diameter of the bolt

D_{br} = deformation of bearing

D_s = deformation of shearing

e = edge distance

E = modulus of elasticity

e = natural base logarithm

F_u = ultimate tensile stress

F_v = nominal shear strength of a fastener

F_y = yielding stress of the plate

g = width or gage of the plate

G_b = shear modulus

I_b = moment of inertia

K = initial slope of the load-deformation curve

$K_1 = K - K_p$

K_p = slope of the load-deformation curve in the extreme yielding range

L_e = edge distance

m = number of the shear planes

n = load-deformation curve shape parameter

p = spacing between the holes

P = tension force on the coupon

R = bolt force

R_1 = predicted ultimate load at 0.25 in. of deformation

R_2 = actual load value at a deformation of 0.25 in.

R_3 = maximum load value

R_0 = bolt reference load

R_0 = load at a deformation of 0.30 in.

R_{tv} = load value at a deformation of 0.25 in. and 0.16 in. for bearing/tear-out and bolt shear failures, respectively

R_u = ultimate strength of the connection

R_{ult} = ultimate shear load of a single fastener

t = thickness of the plate

t = web or plate thickness

t' = thickness of the plate

APPENDIX B

MEASURED MATERIAL

PROPERTIES

MEASURED MATERIAL PROPERTIES

Table B-1

DESCRIPTION	WIDTH	THICKNESS	AREA	ELONGATION	Fy (ksi)	Fu (ksi)	Fu/Fy
PL 1-1	1.51	0.251	0.379	31%	45	65	1.44
PL 1-2	1.5	0.251	0.377	31%	46	65	1.41
PL 2-1	1.51	0.25	0.378	30%	46	65.5	1.42
PL 2-2	1.51	0.25	0.378	31%	45.5	65.5	1.44
PL 3-1	1.5	0.625	0.938	29%	44	67	1.52
PL 3-2	1.5	0.625	0.938	30%	45	68	1.51
PL 5-1	1.5	0.995	1.493	30%	43.9	70	1.59
PL 5-2	1.5	0.996	1.494	29%	43	70	1.63
PL 6-1	1.49	0.998	1.487	30%	43	67	1.56
PL 6-2	1.49	0.999	1.489	31%	44	67	1.52
PL 7-1	1.5	0.75	1.125	29%	45	67	1.49
PL 7-2	1.5	0.75	1.125	30%	45	67	1.49
PL 8-1	1.5	0.75	1.125	31%	45	68	1.51
PL 8-2	1.5	0.75	1.125	30%	45	68	1.51
PL 9-1	1.5	0.75	1.125	29%	45.5	69	1.52
PL 9-2	1.5	0.75	1.125	30%	46	69	1.50
PL 10-1	1.5	0.375	0.563	32%	51	74	1.45
PL 10-2	1.5	0.375	0.563	31%	51	74	1.45
PL 11-1	1.5	0.5	0.750	29%	52.5	74.5	1.42
PL 11-2	1.5	0.5	0.750	30%	54	75	1.39
PL 12-1	1.5	0.5	0.750	31%	51	74.5	1.46
PL 12-2	1.5	0.5	0.750	30%	52	74.5	1.43
PL 13-1	1.5	0.625	0.938	29%	47	70	1.49
PL 13-2	1.5	0.625	0.938	31%	46.5	70	1.51
PL 15-1	1.49	0.121	0.180	32%	42.8	60.9	1.42
PL 15-2	1.49	0.12	0.179	31%	43.8	61.8	1.41
PL 16-1	1.498	0.121	0.181	29%	42.6	60.7	1.42
PL 16-2	1.497	0.119	0.178	29%	43.1	61.5	1.43
PL 17-1	1.497	0.12	0.180	29%	44.5	62	1.39
PL 17-2	1.5	0.12	0.180	32%	43.8	62	1.42
PL 18-1	1.5	0.249	0.374	29%	47.8	66.9	1.40
PL 18-2	1.49	0.248	0.370	29%	47.2	66.5	1.41
PL 19-1	1.5	0.246	0.369	29%	47.1	66.8	1.42
PL 19-2	1.5	0.249	0.374	29%	46.7	66.4	1.42
PL 20-1	1.497	0.248	0.371	28%	45.9	66.4	1.45
PL 20-2	1.498	0.25	0.375	31%	46.3	65.9	1.42
PL 21-1	1.49	0.367	0.547	29%	43.7	63.7	1.46
PL 21-2	1.499	0.37	0.555	29%	43.1	63.6	1.48

Table B-1 (Contd.)

DESCRIPTION	WIDTH	THICKNESS	AREA	ELONGATION	Fy (ksi)	Fu (ksi)	Fu/Fy
PL 22-1	1.49	0.367	0.547	30%	44.3	63.8	1.44
PL 22-2	1.49	0.37	0.551	29%	42.5	63.9	1.50
PL 23-1	1.5	0.367	0.551	29%	44.1	63.8	1.45
PL 23-2	1.49	0.37	0.551	29%	43.6	63.8	1.46
PL 24-1	1.5	0.369	0.554	29%	42.9	63.7	1.48
PL 24-2	1.5	0.367	0.551	29%	43.7	63.6	1.46
PL 25-1	1.5	0.371	0.557	30%	43.3	63.7	1.47
PL 25-2	1.5	0.368	0.552	30%	44.1	63.7	1.44
PL 26-1	1.49	0.5	0.745	31%	43.3	64.3	1.48
PL 26-2	1.49	0.5	0.745	30%	44.5	64.4	1.45
PL 27-1	1.5	0.624	0.936	30%	45	68.4	1.52
PL 27-2	1.5	0.622	0.933	29%	44.7	67.8	1.52
PL 27a-1	1.5	0.627	0.941	30%	45.1	68.5	1.52
PL 27a-1	1.5	0.623	0.935	29%	45.7	68.3	1.49
PL 28-1	1.5	0.749	1.124	29%	44.7	68.9	1.54
PL 28-2	1.5	0.75	1.125	31%	44.9	69.1	1.54
PL 29-1	1.5	0.75	1.125	29%	44.8	71.9	1.60
PL 29-2	1.5	0.749	1.124	30%	44.5	68.9	1.55
PL 30-1	1.5	0.997	1.496	30%	40.1	66.3	1.65
PL 30-2	1.5	0.998	1.497	32%	40.6	66.4	1.64
PL 31-1	1.5	1	1.500	32%	41.8	67.9	1.62
PL 31-2	1.5	1	1.500	31%	42.5	67.7	1.59
PL 32-1	1.5	1	1.500	30%	41.1	67.4	1.64
PL 32-2	1.5	1	1.500	31%	41.8	67.7	1.62
PL 33-1	1.5	0.491	0.737	28%	52.9	73.8	1.40
PL 33-2	1.5	0.491	0.737	28%	53.7	74.1	1.38
PL 34-1	1.5	0.493	0.740	29%	51.4	73.3	1.43
PL 34-2	1.5	0.493	0.740	28%	52.2	74.4	1.43
PL 35-1	1.5	0.486	0.729	27%	52.9	73.8	1.40
PL 35-2	1.5	0.486	0.729	28%	52.4	73.4	1.40
PL 40-1	1.5	0.246	0.369	31%	47.9	66.6	1.39
PL 40-2	1.5	0.246	0.369	30%	47.9	67.3	1.41
PL 41-1	1.5	0.247	0.371	31%	47.6	65.9	1.38
PL 41-2	1.5	0.248	0.372	31%	47.9	70.6	1.47
PL 42-1	1.5	0.496	0.744	30%	47.1	71.1	1.51
PL 42-2	1.5	0.495	0.743	29%	46.5	70.5	1.52
PL 43-1	1.5	0.627	0.941	31%	44.2	64	1.45
PL 43-2	1.5	0.625	0.938	31%	43.2	62.6	1.45
PL 44-1	1.5	0.748	1.122	30%	44.2	67.7	1.53
PL 44-2	1.5	0.742	1.113	31%	44.7	67.8	1.52

APPENDIX C

SUMMARIES OF THE TESTS

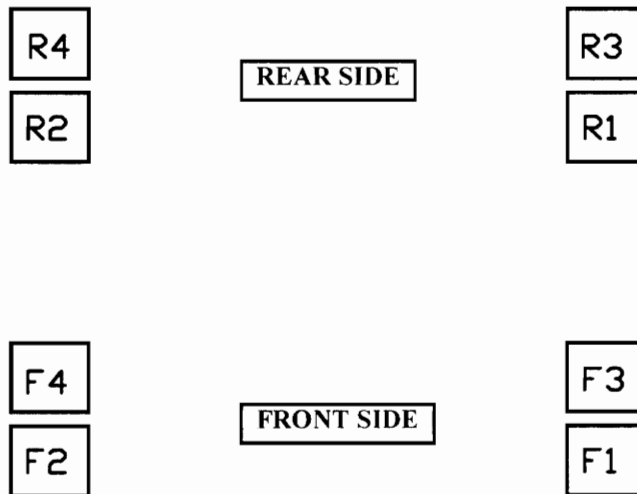

LOCATION OF THE POTENTIOMETERS
USED IN THE TESTING PROGRAM

TENSION TESTS ON BOLTED CONNECTIONS

SUMMARY SHEET

Test No: 1

Date: February 17, 1995

Test Designation: 1/4x1/4x3/4

Recorder: Burak Karsu

GEOMETRIC AND MATERIAL PROPERTIES

BOLT

Type: A325 Diameter $d_b = 0.750$ in. Length $L_b = 2.0$ in.

Shear Str. $F_v = 72$ ksi Edge Dist. $e = 1.5$ in. Fully Pretensioned-- Yes

Bolt Hole Fabr.-- Drilled

Bolt Hole Type-- Standard

Threads in Shear Plane-- X

PLATES

No	Designation	Length (in.)	Width (in.)	Thickness (in.)	Hole Dia. (in.)	Fy (ksi)	Fu (ksi)
Plate 1	PL-2	24.0	5.0	0.25	13/16	46	65
Plate 2	PL-2	24.0	5.0	0.25	13/16	46	65

TEST RESULTS

Failure Type: Bearing / Tear Out

Failure Load: 28900 lbs/plate

Max Deflection $\Delta_{max} = 1.21$ in.

Failure Plate: 1/4-in. rear, bottom plate

COMMENTS

- * At a load of 7500 lbs. straightening of plates was observed.
- * First yielding started in front of the bolt on the 1/4-in. rear side plate at 20000 lbs.
- * Plate curling and bulging on the tips of the plates were observed at 22000 lbs.
- * At 23000 lbs. yielding started on the sides of the plates in line with the bolts.
- * Corners started peeling back at 23500 lbs.
- * Bulging got significant, excessive deformations occurred in front of the bolts at 26000 lbs.
- * Signs of tear out appeared at 27000 lbs.

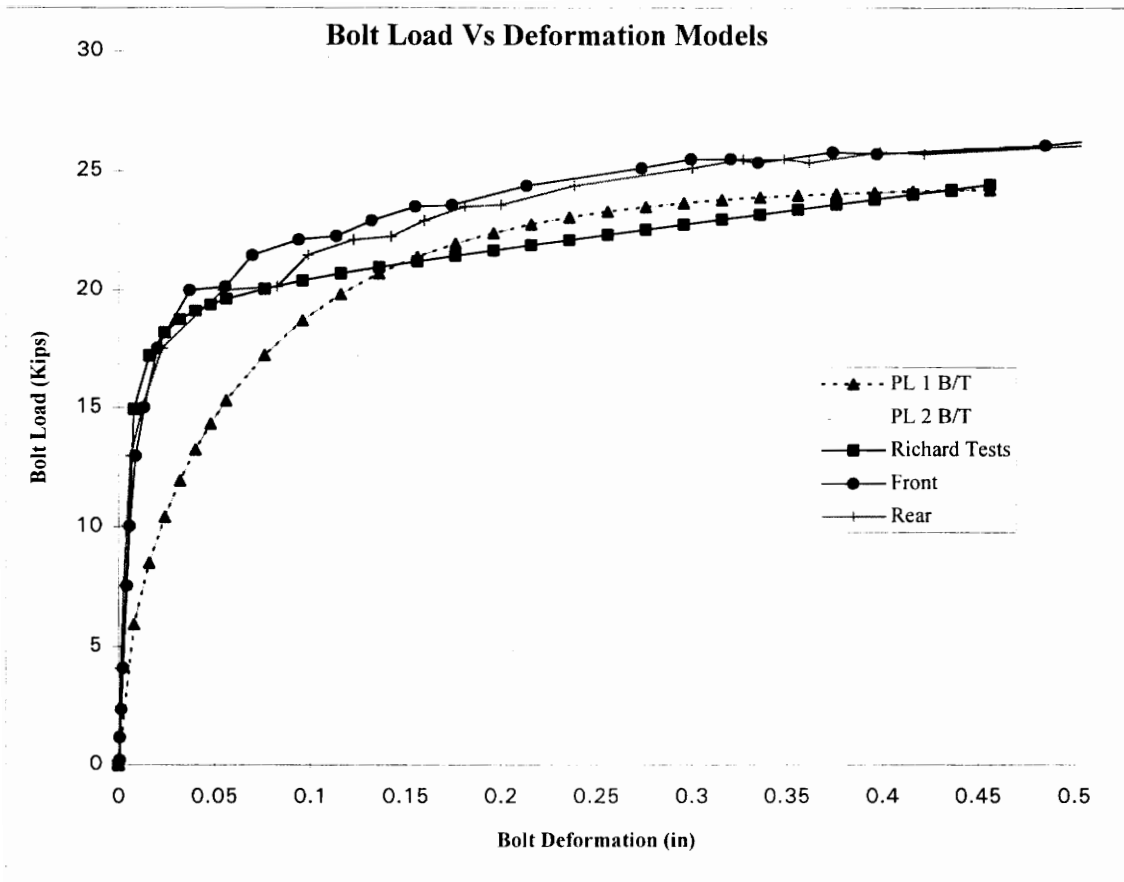

Figure C-1

Plate			Bolt		
	tp	Fu	B/T	A325	
Plate 1	0.25	65	24.38	Bolt Dia.	0.75
Plate 2	0.25	65	24.38	Fv	72
				Bolt Shear	35.7847

Richard Coefficients

K= 7250	Kp= 10	Ro= 20
K1= 7240	n= 1	

Data Points	Volts	Load	90	91	92	93	94	95	96	97	AVG(F)	AVG(R)
1	0.01	0.2	-0.001	-0.001	-0.001	0.000	0.000	-0.001	-0.001	-0.001	0.001	0.000
2	0.08	1.2	-0.001	-0.002	0.000	-0.001	0.000	-0.001	0.000	-0.001	0.001	0.000
3	0.16	2.3	-0.002	-0.003	0.000	-0.001	-0.001	-0.001	0.000	-0.001	0.002	0.001
4	0.27	4.1	-0.003	-0.004	-0.001	-0.001	-0.002	-0.001	-0.001	-0.001	0.002	0.001
5	0.50	7.5	-0.005	-0.007	-0.002	-0.004	-0.004	-0.001	-0.005	-0.001	0.004	0.003
6	0.67	10.0	-0.005	-0.011	-0.002	-0.006	-0.007	-0.002	-0.008	-0.001	0.006	0.004
7	0.86	13.0	-0.005	-0.017	-0.002	-0.012	-0.011	-0.002	-0.012	-0.001	0.009	0.006
8	1.00	15.0	-0.007	-0.024	-0.004	-0.019	-0.018	-0.007	-0.019	-0.006	0.013	0.013
9	1.17	17.5	-0.013	-0.032	-0.009	-0.028	-0.026	-0.018	-0.027	-0.018	0.020	0.023
10	1.33	20.0	-0.031	-0.048	-0.026	-0.043	-0.056	-0.053	-0.057	-0.053	0.037	0.054
11	1.34	20.2	-0.050	-0.065	-0.046	-0.061	-0.083	-0.080	-0.085	-0.082	0.056	0.082
12	1.43	21.5	-0.064	-0.080	-0.061	-0.075	-0.098	-0.097	-0.101	-0.099	0.070	0.099
13	1.48	22.1	-0.088	-0.104	-0.085	-0.099	-0.121	-0.122	-0.125	-0.124	0.094	0.123
14	1.48	22.3	-0.108	-0.124	-0.105	-0.118	-0.140	-0.141	-0.144	-0.144	0.114	0.142
15	1.53	22.9	-0.127	-0.143	-0.123	-0.136	-0.157	-0.158	-0.162	-0.161	0.132	0.160
16	1.57	23.5	-0.150	-0.166	-0.145	-0.158	-0.178	-0.180	-0.183	-0.183	0.155	0.181
17	1.57	23.6	-0.170	-0.185	-0.164	-0.178	-0.196	-0.199	-0.202	-0.203	0.174	0.200
18	1.63	24.4	-0.210	-0.224	-0.202	-0.216	-0.234	-0.237	-0.241	-0.242	0.213	0.238
19	1.68	25.1	-0.272	-0.283	-0.263	-0.277	-0.295	-0.299	-0.303	-0.305	0.274	0.300
20	1.70	25.5	-0.298	-0.310	-0.289	-0.303	-0.322	-0.325	-0.329	-0.331	0.300	0.327
21	1.70	25.5	-0.319	-0.330	-0.310	-0.323	-0.344	-0.347	-0.351	-0.353	0.321	0.348
22	1.69	25.4	-0.333	-0.346	-0.324	-0.338	-0.357	-0.360	-0.364	-0.366	0.335	0.362
23	1.72	25.8	-0.371	-0.384	-0.364	-0.377	-0.394	-0.397	-0.401	-0.403	0.374	0.399
24	1.71	25.7	-0.394	-0.407	-0.387	-0.400	-0.417	-0.421	-0.423	-0.426	0.397	0.422
25	1.74	26.1	-0.481	-0.494	-0.476	-0.488	-0.502	-0.506	-0.508	-0.510	0.485	0.506
26	1.77	26.5	-0.531	-0.544	-0.527	-0.540	-0.552	-0.556	-0.558	-0.560	0.536	0.557
27	1.80	27.0	-0.630	-0.642	-0.623	-0.636	-0.647	-0.650	-0.652	-0.654	0.633	0.650
28	1.81	27.2	-0.681	-0.692	-0.675	-0.688	-0.699	-0.703	-0.705	-0.707	0.684	0.703
29	1.79	26.8	-0.727	-0.738	-0.720	-0.732	-0.743	-0.747	-0.751	-0.753	0.729	0.748
30	1.85	27.7	-0.789	-0.798	-0.777	-0.788	-0.801	-0.806	-0.810	-0.813	0.788	0.808
31	1.85	27.8	-0.835	-0.845	-0.824	-0.839	-0.850	-0.855	-0.857	-0.859	0.836	0.855
32	1.88	28.1	-0.881	-0.891	-0.872	-0.886	-0.895	-0.900	-0.902	-0.904	0.882	0.900
33	1.91	28.7	-0.969	-0.981	-0.962	-0.977	-0.989	-0.995	-0.999	-1.003	0.972	0.997
34	1.92	28.9	-1.057	-1.068	-1.051	-1.068	-1.088	-1.096	-1.102	-1.107	1.061	1.098
35	1.62	24.3	-1.062	-1.073	-1.056	-1.072	-1.154	-1.160	-1.172	-1.177	1.066	1.166
36	1.10	16.5	-1.061	-1.072	-1.053	-1.070	-1.206	-1.214	-1.235	-1.238	1.064	1.224
37	1.09	16.4	-1.060	-1.072	-1.053	-1.070	-1.206	-1.214	-1.234	-1.238	1.064	1.223
38	0.01	0.1	-1.023	-1.046	-1.025	-1.055	-1.179	-1.195	-1.221	-1.228	1.037	1.206

Table C-1

TENSION TESTS ON BOLTED CONNECTIONS

SUMMARY SHEET

Test No: 2

Date: February 21, 1995

Test Designation: 1/4x3/8x3/4

Recorder: Burak Karsu

GEOMETRIC AND MATERIAL PROPERTIES

BOLT

Type: A325

Diameter $d_b = 0.750$ in.

Length $L_b = 2.0$ in.

Shear Str. $F_v = 72$ ksi

Edge Dist. $e = 1.5$ in.

Fully Pretensioned-- Yes

Bolt Hole Fabr.-- Drilled

Bolt Hole Type-- Standard

Threads in Shear Plane-- X

PLATES

No	Designation	Length (in.)	Width (in.)	Thickness (in.)	Hole Dia. (in.)	Fy (ksi)	Fu (ksi)
Plate 1	PL-2	24.0	5.0	0.25	13/16	46	65
Plate 2	PL-10	24.0	4.0	0.375	13/16	51	74

TEST RESULTS

Failure Type: Bearing / Tear Out

Failure Load: 29240 lbs.

Max Deflection $\Delta_{max} = .602$ in.

Failure Plate: 1/4-in. front, bottom plate.

COMMENTS

- * Significant deformations in PL-2 started at 16000 lbs. as no change occurred in PL-10.
- * Bulging increased in front of the bolt in PL-2 at 17000 lbs.
- * Tips of PL-2 bended at 18500 lbs.
- * Bolts decline at 26500 lbs.
- * Rupture in PL-2 at 29240 lbs. with 0.61 in. of deformation.
- * When compared to Test 1, there is a significant change in the ultimate deformation as no major difference occurred in the rupture load.

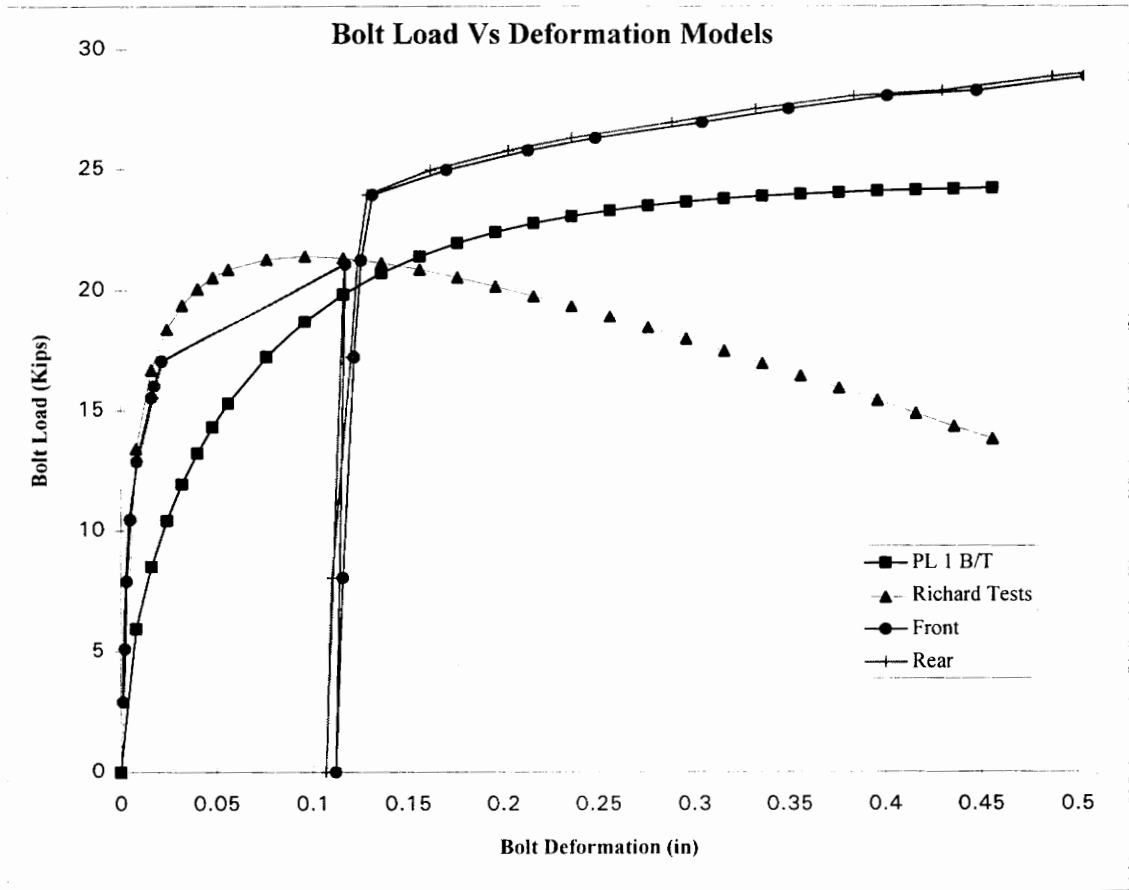

Figure C-2

Plate				Bolt	
	tp	Fu	B/T	A325	Bolt Dia.
Plate 1	0.25	65	24.38		0.75
Plate 2	0.375	74	41.63		
				Fv	72
				Bolt Shear	35.785

Richard Coefficients

K = 8700 Kp = -30 Ro = 30
 K1 = 8730 n = 0.6

Data Point	Volts	Load	F1	F2	F3	F4	B1	B2	B3	B4	Avg(F)	Avg(B)
1	2920.5315	2.92	-0.002	-0.001	-0.002	-0.001	-0.002	0.001	-0.002	0.000	0.001	0.001
2	5117.7975	5.12	-0.006	-0.001	-0.002	-0.001	-0.002	0.001	-0.004	-0.001	0.002	0.002
3	7901.001	7.90	-0.007	-0.002	-0.002	-0.001	-0.004	-0.001	-0.005	-0.001	0.003	0.003
4	10464.477	10.46	-0.012	-0.002	-0.005	-0.001	-0.005	-0.002	-0.007	-0.002	0.005	0.004
5	12890.625	12.89	-0.018	-0.003	-0.011	-0.001	-0.010	-0.006	-0.013	-0.006	0.008	0.009
6	15527.34	15.53	-0.028	-0.010	-0.020	-0.008	-0.020	-0.012	-0.023	-0.012	0.016	0.017
7	16030.89	16.03	-0.029	-0.011	-0.020	-0.010	-0.022	-0.013	-0.024	-0.013	0.017	0.018
8	17056.275	17.06	-0.033	-0.015	-0.024	-0.013	-0.026	-0.016	-0.029	-0.016	0.021	0.022
9	21057.135	21.06	-0.140	-0.110	-0.121	-0.098	-0.133	-0.092	-0.143	-0.099	0.117	0.117
10	0	0.00	-0.133	-0.106	-0.117	-0.093	-0.119	-0.083	-0.131	-0.094	0.112	0.107
11	8047.485	8.05	-0.138	-0.108	-0.121	-0.096	-0.125	-0.085	-0.136	-0.094	0.116	0.110
12	17211.915	17.21	-0.147	-0.111	-0.128	-0.100	-0.142	-0.091	-0.150	-0.097	0.122	0.120
13	21240.24	21.24	-0.150	-0.116	-0.132	-0.105	-0.145	-0.095	-0.155	-0.100	0.126	0.124
14	23950.2	23.95	-0.157	-0.121	-0.138	-0.109	-0.152	-0.099	-0.161	-0.103	0.131	0.129
15	24975.585	24.98	-0.197	-0.161	-0.175	-0.148	-0.184	-0.130	-0.195	-0.137	0.170	0.162
16	25781.25	25.78	-0.240	-0.205	-0.217	-0.190	-0.225	-0.169	-0.237	-0.178	0.213	0.202
17	26293.95	26.29	-0.276	-0.240	-0.252	-0.225	-0.258	-0.202	-0.271	-0.211	0.248	0.236
18	26953.125	26.95	-0.333	-0.297	-0.308	-0.279	-0.310	-0.254	-0.327	-0.263	0.305	0.289
19	27539.07	27.54	-0.380	-0.342	-0.354	-0.324	-0.355	-0.298	-0.371	-0.306	0.350	0.333
20	28070.07	28.07	-0.431	-0.394	-0.404	-0.376	-0.406	-0.349	-0.423	-0.358	0.401	0.384
21	28289.79	28.29	-0.478	-0.440	-0.451	-0.423	-0.451	-0.395	-0.470	-0.404	0.448	0.430
22	28875.735	28.88	-0.535	-0.496	-0.510	-0.479	-0.508	-0.452	-0.528	-0.460	0.505	0.487
23	29241.945	29.24	-0.580	-0.540	-0.554	-0.523	-0.554	-0.497	-0.574	-0.507	0.549	0.533
24	29241.945	29.24	-0.633	-0.593	-0.606	-0.575	-0.605	-0.549	-0.627	-0.560	0.602	0.586

Table C-2

TENSION TESTS ON BOLTED CONNECTIONS

SUMMARY SHEET

Test No: 3

Date: February 27,1995

Test Designation: 1/4x1/2x3/4

Recorder: Burak Karsu

GEOMETRIC AND MATERIAL PROPERTIES

BOLT

Type: A325

Diameter $d_b = 0.75$ in.

Length $L_b = 2.25$ in.

Shear Str. $F_v = 72$ ksi

Edge Dist. $e = 1.5$ in.

Fully Pretensioned-- Yes

Bolt Hole Fabr.-- Drilled

Bolt Hole Type-- Standard

Threads in Shear Plane-- X

PLATES

<u>No</u>	<u>Designation</u>	<u>Length (in.)</u>	<u>Width (in.)</u>	<u>Thickness (in.)</u>	<u>Hole Dia. (in.)</u>	<u>Fy (ksi)</u>	<u>Fu (ksi)</u>
Plate 1	PL-2	24.0	5.0	0.25	13/16	46	65
Plate 2	PL-12	24.0	5.0	0.50	13/16	52	74

TEST RESULTS

Failure Type: Bearing / Tear Out

Failure Load: 29100 lbs/plate

Max Deflection $\Delta_{max} = 0.80$ in.

Failure Plate: 1/4-in. top, rear plate.

COMMENTS

- * Yielding started in front of the bolt on PL-2 at 13000 lbs.
- * Yielding on the sides of PL-2 started at 19500 lbs.
- * Bulging was observed on PL-2 at a load of 21200 lbs.
- * Yielding on PL-12 at load 23500 lbs.
- * Excessive bolt hole elongation at a load of 24500 lbs on PL-2.
- * PL-2 teared out at a load of 29100 lbs.

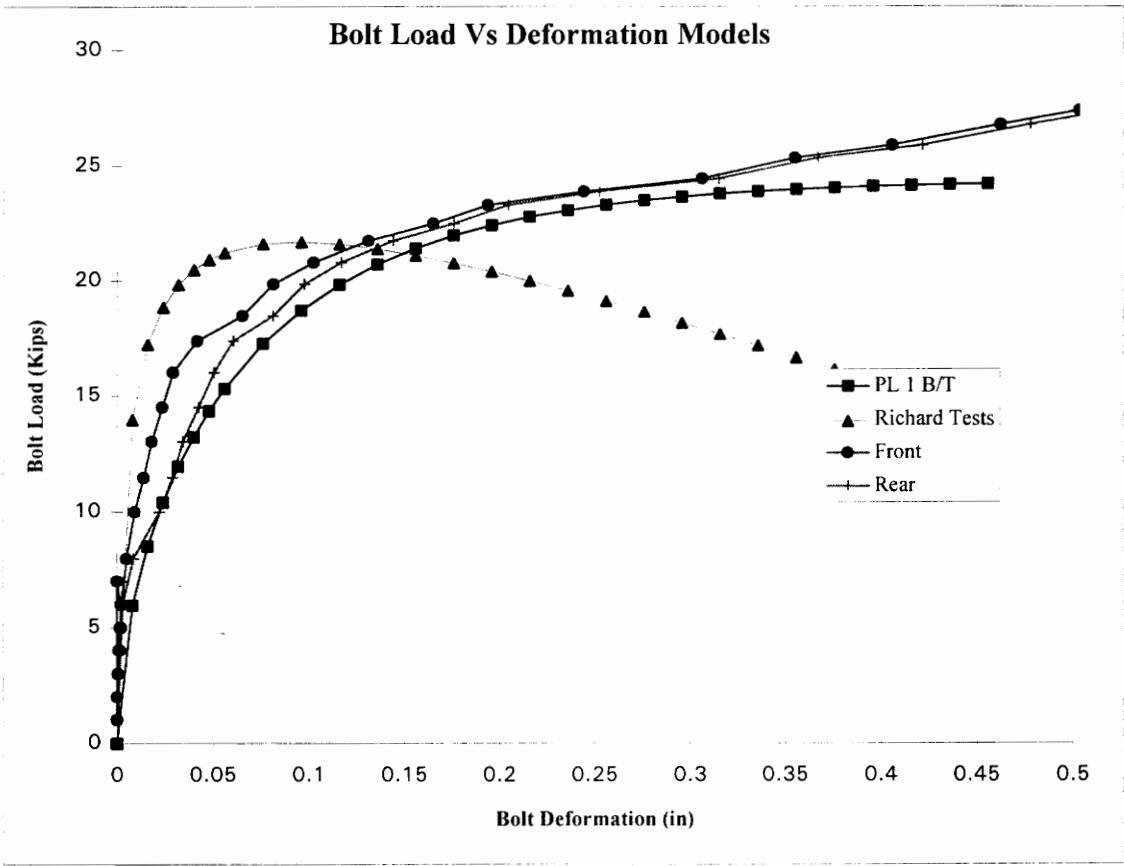

Figure C-3

Plate				Bolt	A325
	tp	Fu	B/T	Bolt Dia.	0.75
Plate 1	0.25	65	24.38	Fv	72
Plate 2	0.5	74	55.50	Bolt Shear	35.7847

Richard Coefficients

K= 9667 Kp= -30 Ro= 30
 K1= 9697 n= 0.6

Data Point	Volts	Load	F1	F2	F3	F4	B1	B2	B3	B4	AVG(F)	AVG(R)
1	2	1	0	0	0	0	0	0	0	0	0.000	0.000
2	4	2	0	0	0	0	0	0	1	0	0.000	0.000
3	6	3	1	1	0	0	0	0	1	1	0.001	0.001
4	8	4	2	2	0	0	0	0	1	1	0.001	0.001
5	10	5	3	3	0	3	0	0	3	3	0.002	0.002
6	12	6	4	4	0	0	0	1	4	4	0.002	0.002
7	14	7	0	0	0	0	0	2	6	6	0.000	0.004
8	2	1	1	0	0	0	0	2	0	0	0.000	0.001
9	8	4	3	3	0	0	0	0	1	3	0.002	0.001
10	10	5	4	3	0	0	0	0	3	4	0.002	0.002
11	12	6	6	5	0	0	0	0	5	8	0.003	0.003
12	16	8	13	7	0	0	0	0	8	26	0.005	0.009
13	20	10	15	12	6	4	11	24	19	34	0.009	0.022
14	22.95	11.475	20	19	7	10	17	31	26	42	0.014	0.029
15	26.1	13.05	24	25	10	14	20	37	31	49	0.018	0.034
16	29	14.5	29	34	12	20	26	45	39	60	0.024	0.043
17	32	16	34	41	15	27	33	53	47	69	0.029	0.051
18	34.7	17.35	47	56	25	39	40	63	58	81	0.042	0.061
19	36.9	18.45	70	83	45	63	58	83	79	105	0.065	0.081
20	39.7	19.85	87	101	59	79	73	99	96	123	0.082	0.098
21	41.6	20.8	108	123	79	100	90	118	116	144	0.103	0.117
22	43.5	21.75	137	154	105	129	115	144	143	174	0.131	0.144
23	45	22.5	171	189	138	163	145	175	177	207	0.165	0.176
24	46.6	23.3	200	220	166	190	172	203	206	237	0.194	0.205
25	47.8	23.9	252	272	214	240	218	250	256	286	0.245	0.253
26	48.9	24.45	314	337	274	301	279	312	320	350	0.307	0.315
27	50.7	25.35	364	386	321	350	330	364	372	403	0.355	0.367
28	51.8	25.9	416	438	370	400	383	418	426	460	0.406	0.422
29	53.6	26.8	472	496	425	456	437	474	483	517	0.462	0.478
30	54.8	27.4	513	537	466	497	478	516	526	558	0.503	0.520
31	55	27.5	562	586	515	546	527	564	576	609	0.552	0.569
32	55.1	27.55	615	639	567	598	578	617	628	661	0.605	0.621

Table C-3

Data Point	Volts	Load	F1	F2	F3	F4	B1	B2	B3	B4	AVG(F)	AVG(R)
1	2	1	0	0	0	0	0	0	0	0	0.000	0.000
2	4	2	0	0	0	0	0	0	1	0	0.000	0.000
3	6	3	1	1	0	0	0	0	1	1	0.001	0.001
4	8	4	2	2	0	0	0	0	1	1	0.001	0.001
5	10	5	3	3	0	3	0	0	3	3	0.002	0.002
6	12	6	4	4	0	0	0	1	4	4	0.002	0.002
7	14	7	0	0	0	0	0	2	6	6	0.000	0.004
8	2	1	1	0	0	0	0	2	0	0	0.000	0.001
9	8	4	3	3	0	0	0	0	1	3	0.002	0.001
10	10	5	4	3	0	0	0	0	3	4	0.002	0.002
11	12	6	6	5	0	0	0	0	5	8	0.003	0.003
12	16	8	13	7	0	0	0	0	8	26	0.005	0.009
13	20	10	15	12	6	4	11	24	19	34	0.009	0.022
14	22.95	11.475	20	19	7	10	17	31	26	42	0.014	0.029
15	26.1	13.05	24	25	10	14	20	37	31	49	0.018	0.034
16	29	14.5	29	34	12	20	26	45	39	60	0.024	0.043
17	32	16	34	41	15	27	33	53	47	69	0.029	0.051
18	34.7	17.35	47	56	25	39	40	63	58	81	0.042	0.061
19	36.9	18.45	70	83	45	63	58	83	79	105	0.065	0.081
20	39.7	19.85	87	101	59	79	73	99	96	123	0.082	0.098
21	41.6	20.8	108	123	79	100	90	118	116	144	0.103	0.117
22	43.5	21.75	137	154	105	129	115	144	143	174	0.131	0.144
23	45	22.5	171	189	138	163	145	175	177	207	0.165	0.176
24	46.6	23.3	200	220	166	190	172	203	206	237	0.194	0.205
25	47.8	23.9	252	272	214	240	218	250	256	286	0.245	0.253
26	48.9	24.45	314	337	274	301	279	312	320	350	0.307	0.315
27	50.7	25.35	364	386	321	350	330	364	372	403	0.355	0.367
28	51.8	25.9	416	438	370	400	383	418	426	460	0.406	0.422
29	53.6	26.8	472	496	425	456	437	474	483	517	0.462	0.478
30	54.8	27.4	513	537	466	497	478	516	526	558	0.503	0.520
31	55	27.5	562	586	515	546	527	564	576	609	0.552	0.569
32	55.1	27.55	615	639	567	598	578	617	628	661	0.605	0.621

Table C-3

Data Point	Volts	Load	F1	F2	F3	F4	R1	R2	R3	R4	AVG(F)	AVG(R)
1	0.02	1.37	0.000	0.000	-0.001	-0.001	0.000	-0.001	0.000	-0.001	0.000	0.000
2	0.05	1.81	0.000	0.000	-0.001	-0.001	-0.001	-0.001	0.000	-0.001	0.001	0.001
3	0.06	1.88	-0.001	0.000	-0.001	-0.001	-0.001	-0.001	0.000	-0.001	0.001	0.001
4	0.07	2.10	-0.001	0.000	-0.001	-0.001	-0.001	-0.001	0.000	-0.001	0.001	0.001
5	0.11	2.61	-0.001	0.001	-0.002	-0.002	-0.001	-0.002	0.000	-0.001	0.001	0.001
6	0.12	2.83	-0.001	0.001	-0.002	-0.002	-0.002	-0.002	0.000	-0.001	0.001	0.001
7	0.14	3.05	-0.001	0.001	-0.002	-0.002	-0.002	-0.003	0.000	-0.001	0.001	0.001
8	0.18	3.64	-0.001	0.001	-0.004	-0.002	-0.002	-0.004	0.000	-0.001	0.002	0.002
9	0.21	4.08	-0.001	0.001	-0.004	-0.002	-0.003	-0.005	0.000	-0.001	0.002	0.002
10	0.24	4.59	-0.001	0.001	-0.004	-0.003	-0.004	-0.006	0.000	-0.001	0.002	0.002
11	0.30	5.54	-0.002	0.000	-0.006	-0.004	-0.004	-0.007	0.000	-0.001	0.003	0.003
12	0.34	6.13	-0.002	0.000	-0.007	-0.004	-0.004	-0.008	0.000	-0.001	0.003	0.003
13	0.41	7.08	-0.002	0.000	-0.008	-0.005	-0.005	-0.010	0.001	-0.002	0.004	0.004
14	0.48	8.18	-0.002	-0.001	-0.009	-0.006	-0.006	-0.012	0.000	-0.002	0.004	0.005
15	0.54	9.06	-0.003	0.000	-0.011	-0.006	-0.007	-0.013	0.000	-0.003	0.005	0.006
16	0.66	10.97	-0.006	0.001	-0.017	-0.007	-0.007	-0.020	0.000	-0.007	0.007	0.008
17	0.76	12.36	-0.010	0.000	-0.023	-0.009	-0.010	-0.028	0.000	-0.013	0.010	0.013
18	0.82	13.24	-0.013	-0.001	-0.027	-0.012	-0.012	-0.032	-0.001	-0.017	0.013	0.016
19	0.92	14.78	-0.018	-0.003	-0.034	-0.016	-0.015	-0.040	-0.002	-0.021	0.018	0.020
20	1.04	16.61	-0.026	-0.007	-0.044	-0.023	-0.020	-0.048	-0.003	-0.027	0.025	0.024
21	1.12	17.80	-0.030	-0.010	-0.051	-0.028	-0.023	-0.054	-0.005	-0.031	0.030	0.028
22	1.22	19.26	-0.039	-0.017	-0.061	-0.037	-0.028	-0.062	-0.008	-0.036	0.038	0.034
23	1.31	20.66	-0.046	-0.023	-0.072	-0.046	-0.034	-0.072	-0.012	-0.043	0.047	0.040
24	1.44	22.56	-0.064	-0.036	-0.094	-0.064	-0.051	-0.092	-0.025	-0.058	0.064	0.056
25	1.47	23.00	-0.070	-0.040	-0.100	-0.069	-0.056	-0.097	-0.029	-0.063	0.070	0.061
26	1.57	24.61	-0.091	-0.057	-0.124	-0.090	-0.076	-0.121	-0.045	-0.083	0.090	0.081
27	1.64	25.64	-0.106	-0.069	-0.142	-0.106	-0.092	-0.137	-0.057	-0.097	0.106	0.096
28	1.72	26.74	-0.122	-0.083	-0.161	-0.122	-0.108	-0.154	-0.072	-0.112	0.122	0.111
29	1.78	27.76	-0.153	-0.111	-0.194	-0.155	-0.139	-0.186	-0.099	-0.141	0.153	0.141
30	1.81	28.13	-0.202	-0.158	-0.246	-0.205	-0.189	-0.239	-0.147	-0.190	0.203	0.191
31	1.84	28.65	-0.308	-0.264	-0.356	-0.315	-0.300	-0.353	-0.255	-0.300	0.311	0.302
32	1.86	28.87	-0.410	-0.365	-0.459	-0.418	-0.406	-0.460	-0.359	-0.405	0.413	0.407
33	1.88	29.23	-0.511	-0.468	-0.560	-0.522	-0.507	-0.562	-0.458	-0.504	0.515	0.508
34	1.91	29.59	-0.610	-0.568	-0.662	-0.625	-0.607	-0.664	-0.558	-0.604	0.616	0.608
35	1.94	30.03	-0.702	-0.660	-0.755	-0.718	-0.700	-0.758	-0.648	-0.695	0.709	0.700
36	1.63	25.49	-0.834	-0.797	-0.886	-0.852	-0.835	-0.890	-0.784	-0.829	0.842	0.834
37	1.14	18.17	-0.863	-0.824	-0.915	-0.876	-0.906	-0.950	-0.870	-0.905	0.869	0.908

Table C-4

TENSION TESTS ON BOLTED CONNECTIONS

SUMMARY SHEET

Test No: 5

Date: March 8, 1995

Test Designation: 1/4x3/4x3/4

Recorder: Burak Karsu

GEOMETRIC AND MATERIAL PROPERTIES

BOLT

Type: A325 Diameter $d_b = .75$ in. Length $L_b = 2.75$ in.

Shear Str. $F_v = 72$ ksi Edge Dist. $e = 1.5$ in. Fully Pretensioned-- Yes

Bolt Hole Fabr.-- Drilled

Bolt Hole Type-- Standard

Threads in Shear Plane-- X

PLATES

No	Designation	Length (in.)	Width (in.)	Thickness (in.)	Hole Dia. (in.)	Fy (ksi)	Fu (ksi)
Plate 1	PL-2	24.0	5.0	0.25	13/16	46	65
Plate 2	PL-7	24.0	5.0	0.75	13/16	45	67

TEST RESULTS

Failure Type: Bearing / Tear Out

Failure Load: 28500 lbs/plate

Max Deflection $\Delta_{max} = 0.75$

Failure Plate: 1/4-in front, bottom plate.

COMMENTS

- * Yielding started on PL-2 at 15000 lbs.
- * Bulging on PL-2 started at 19000 lbs.
- * Bolt hole stretching on PL-2 at 25000 lbs.
- * Rupture on PL-2 at 28500 lbs.

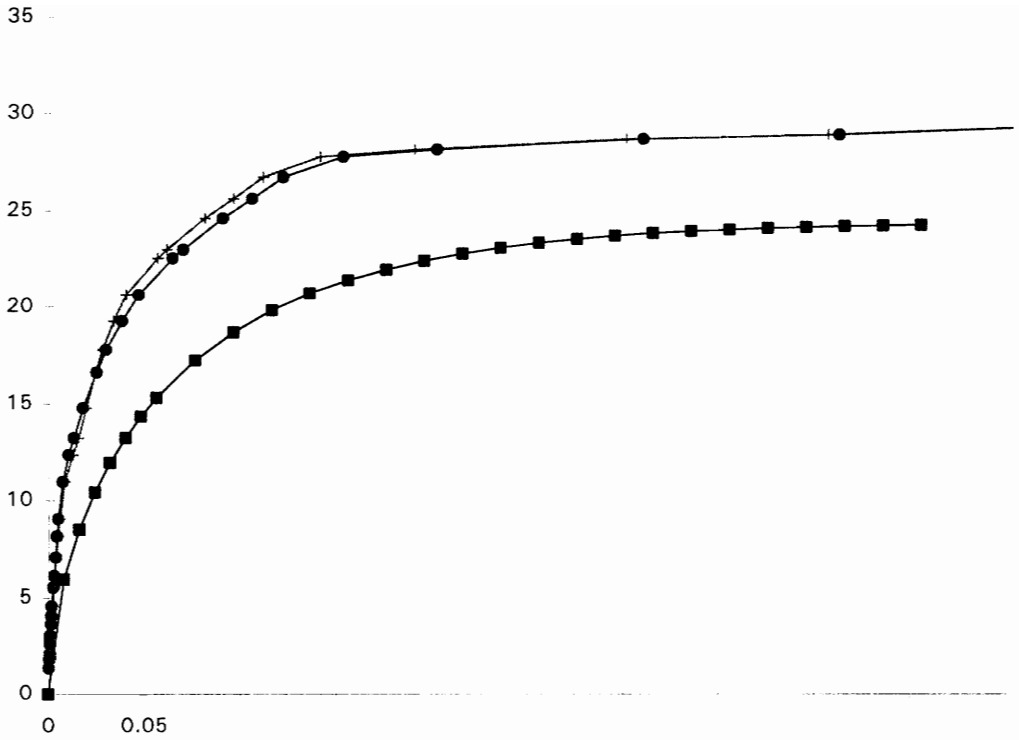

Figure C-5

Plate		Fu	B/T	Bolt		A325
	tp			Bolt Dia.		0.75
Plate 1	0.25	65	24.38	Fv		72
Plate 2	0.75	67	63.10	Bolt Shear		31.8

Richard Coefficients

K= 0 Kp= 0 Ro= 0
 K1= 0 n= 0

0	Volts	LOAD	F1	F2	F3	F4	R1	R2	R3	R4	AVG(F)	AVG(R)
1	0.083	2.245	-0.001	0.000	-0.001	0.000	0.000	-0.001	-0.001	0.000	0.000	0.000
2	0.156	3.344	-0.001	-0.001	-0.002	-0.001	0.000	-0.001	-0.001	-0.001	0.001	0.001
3	0.195	3.930	-0.001	-0.001	-0.002	-0.001	0.000	-0.001	-0.002	-0.001	0.001	0.001
4	0.273	5.102	-0.001	-0.001	-0.003	-0.001	0.000	-0.001	-0.003	-0.001	0.002	0.001
5	0.337	6.054	-0.001	-0.001	-0.003	-0.002	0.000	-0.001	-0.004	-0.001	0.002	0.002
6	0.366	6.493	-0.002	-0.001	-0.004	-0.002	-0.001	-0.001	-0.004	-0.001	0.002	0.002
7	0.396	6.933	-0.002	-0.001	-0.004	-0.003	-0.001	-0.001	-0.004	-0.001	0.003	0.002
8	0.430	7.445	-0.002	-0.002	-0.004	-0.004	-0.001	-0.002	-0.004	-0.001	0.003	0.002
9	0.464	7.958	-0.002	-0.002	-0.004	-0.004	-0.001	-0.002	-0.004	-0.002	0.003	0.002
10	0.498	8.471	-0.003	-0.002	-0.005	-0.004	-0.001	-0.002	-0.004	-0.002	0.004	0.002
11	0.503	8.544	-0.003	-0.002	-0.004	-0.004	-0.001	-0.002	-0.004	-0.002	0.003	0.002
12	0.542	9.130	-0.003	-0.002	-0.004	-0.004	-0.002	-0.002	-0.006	-0.002	0.003	0.003
13	0.615	10.229	-0.003	-0.003	-0.003	-0.004	-0.002	-0.003	-0.006	-0.002	0.003	0.004
14	0.693	11.400	-0.003	-0.003	-0.003	-0.004	-0.002	-0.004	-0.007	-0.003	0.003	0.004
15	0.796	12.938	-0.004	-0.004	-0.004	-0.005	-0.004	-0.005	-0.009	-0.004	0.004	0.005
16	0.864	13.964	-0.006	-0.003	-0.006	-0.005	-0.010	-0.011	-0.016	-0.012	0.005	0.012
17	0.923	14.843	-0.012	-0.006	-0.012	-0.008	-0.024	-0.020	-0.031	-0.021	0.005	0.024
18	1.011	16.161	-0.029	-0.025	-0.031	-0.028	-0.054	-0.043	-0.059	-0.042	0.006	0.049
19	1.143	18.139	-0.061	-0.056	-0.065	-0.061	-0.104	-0.087	-0.105	-0.085	0.008	0.095
20	1.099	17.479	-0.061	-0.056	-0.065	-0.061	-0.104	-0.087	-0.104	-0.085	0.008	0.095
21	1.191	18.871	-0.065	-0.059	-0.069	-0.065	-0.108	-0.090	-0.108	-0.089	0.011	0.099
22	1.377	21.654	-0.072	-0.066	-0.076	-0.072	-0.114	-0.095	-0.116	-0.095	0.019	0.105
23	1.528	23.925	-0.079	-0.072	-0.085	-0.080	-0.122	-0.103	-0.125	-0.102	0.026	0.113
24	1.665	25.976	-0.087	-0.081	-0.094	-0.090	-0.133	-0.111	-0.136	-0.111	0.035	0.123
25	1.772	27.587	-0.098	-0.093	-0.108	-0.103	-0.146	-0.125	-0.152	-0.126	0.047	0.137
26	1.841	28.612	-0.117	-0.111	-0.128	-0.123	-0.167	-0.144	-0.174	-0.146	0.067	0.158
27	1.895	29.418	-0.133	-0.128	-0.145	-0.140	-0.186	-0.163	-0.194	-0.164	0.084	0.177
28	2.026	31.396	-0.189	-0.185	-0.201	-0.197	-0.241	-0.217	-0.253	-0.220	0.140	0.232
29	2.129	32.934	-0.242	-0.238	-0.253	-0.253	-0.297	-0.269	-0.307	-0.271	0.193	0.286
30	2.192	33.886	-0.292	-0.289	-0.304	-0.303	-0.347	-0.319	-0.357	-0.319	0.244	0.335
31	2.261	34.920	-0.338	-0.336	-0.352	-0.350	-0.393	-0.366	-0.405	-0.366	0.291	0.383
32	2.295	35.424	-0.399	-0.395	-0.412	-0.412	-0.454	-0.426	-0.465	-0.427	0.351	0.443
33	2.339	36.083	-0.465	-0.462	-0.480	-0.478	-0.524	-0.494	-0.533	-0.492	0.418	0.511
34	2.354	36.303	-0.504	-0.500	-0.518	-0.518	-0.562	-0.532	-0.572	-0.530	0.457	0.549
35	0.039	1.586	-0.569	-0.566	-0.584	-0.584	-0.628	-0.598	-0.640	-0.596	0.523	0.615

Table C-5

TENSION TESTS ON BOLTED CONNECTIONS

SUMMARY SHEET

Test No: 7

Date: March 8, 1995

Test Designation: 3/8x3/8x3/4

Recorder: Burak Karsu

GEOMETRIC AND MATERIAL PROPERTIES

BOLT

Type: A325

Diameter $d_b = 0.75$ in.

Length $L_b = 2.25$ in.

Shear Str. $F_v = 72$ ksi

Edge Dist. $e = 1.5$ in.

Fully Pretensioned-- No

Bolt Hole Fabr.-- Drilled

Bolt Hole Type-- Standard

Threads in Shear Plane-- X

PLATES

No	Designation	Length (in.)	Width (in.)	Thickness (in.)	Hole Dia. (in.)	Fy (ksi)	Fu (ksi)
Plate 1	PL-10	24.0	4.0	0.375	13/16	51	74
Plate 2	PL-10	24.0	4.0	0.375	13/16	51	74

TEST RESULTS

Failure Type: Bolt Shear

Failure Load: 36300 lbs/plate

Max Deflection $\Delta_{max} = 0.55$ in.

Failure Plate: N/A

COMMENTS

- * Bolts tended to decline at 16000 lbs.
- * Slip of the connection occurred at 17000 lbs. because of non-pretensioning with a banging sound.
- * Yielding on PL-10 was seen at a load of 28500 lbs.
- * PL-10 bended out of plane at 29000 lbs.
- * Tips of the plates curled back at 31000 lbs.
- * Bolt hole stretched at 35000 lbs.
- * Bolt failed in shear at a load of 36300 lbs.

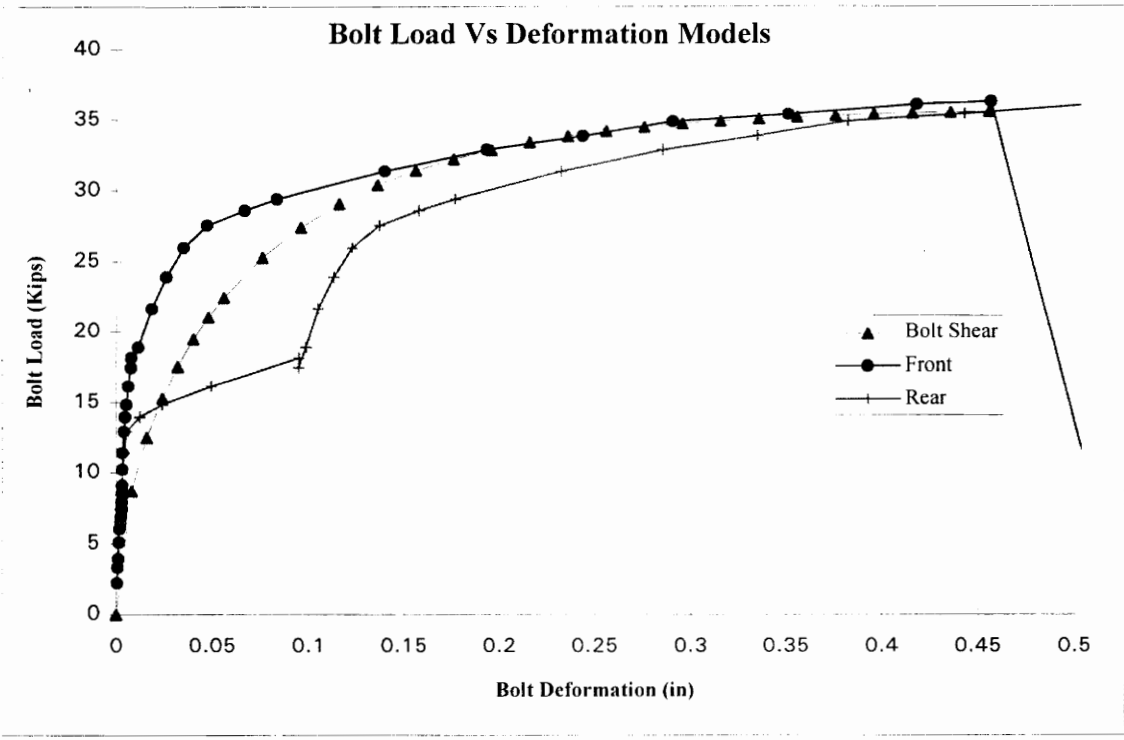

Figure C-7

Plate	tp	Fu	B/T	Bolt	A325
Plate 1	0.375	74	41.63	Bolt Dia.	0.75
Plate 2	0.375	74	41.63	Fv	72
				Bolt Shear	31.8

Richard Coefficients

K = 0 Kp = 0 Ro = 0
 K1 = 0 n = 0

0	Volts	Load	F1	F2	F3	F4	R1	R2	R3	R4	AVG(F)	AVG(R)
1	0.083	2.25	-0.001	0.000	-0.001	0.000	0.000	-0.001	-0.001	0.000	0.000	0.000
2	0.156	3.34	-0.001	-0.001	-0.002	-0.001	0.000	-0.001	-0.001	-0.001	0.001	0.001
3	0.195	3.93	-0.001	-0.001	-0.002	-0.001	0.000	-0.001	-0.002	-0.001	0.001	0.001
4	0.273	5.10	-0.001	-0.001	-0.003	-0.001	0.000	-0.001	-0.003	-0.001	0.002	0.001
5	0.337	6.05	-0.001	-0.001	-0.003	-0.002	0.000	-0.001	-0.004	-0.001	0.002	0.002
6	0.366	6.49	-0.002	-0.001	-0.004	-0.002	-0.001	-0.001	-0.004	-0.001	0.002	0.002
7	0.396	6.93	-0.002	-0.001	-0.004	-0.003	-0.001	-0.001	-0.004	-0.001	0.003	0.002
8	0.430	7.45	-0.002	-0.002	-0.004	-0.004	-0.001	-0.002	-0.004	-0.001	0.003	0.002
9	0.464	7.96	-0.002	-0.002	-0.004	-0.004	-0.001	-0.002	-0.004	-0.002	0.003	0.002
10	0.498	8.47	-0.003	-0.002	-0.005	-0.004	-0.001	-0.002	-0.004	-0.002	0.004	0.002
11	0.503	8.54	-0.003	-0.002	-0.004	-0.004	-0.001	-0.002	-0.004	-0.002	0.003	0.002
12	0.542	9.13	-0.003	-0.002	-0.004	-0.004	-0.002	-0.002	-0.006	-0.002	0.003	0.003
13	0.615	10.23	-0.003	-0.003	-0.003	-0.004	-0.002	-0.003	-0.006	-0.002	0.003	0.004
14	0.693	11.40	-0.003	-0.003	-0.003	-0.004	-0.002	-0.004	-0.007	-0.003	0.003	0.004
15	0.796	12.94	-0.004	-0.004	-0.004	-0.005	-0.004	-0.005	-0.009	-0.004	0.004	0.005
16	0.864	13.96	-0.006	-0.003	-0.006	-0.005	-0.010	-0.011	-0.016	-0.012	0.005	0.012
17	0.923	14.84	-0.012	-0.006	-0.012	-0.008	-0.024	-0.020	-0.031	-0.021	0.009	0.024
18	1.011	16.16	-0.029	-0.025	-0.031	-0.028	-0.054	-0.043	-0.059	-0.042	0.028	0.049
19	1.143	18.14	-0.061	-0.056	-0.065	-0.061	-0.104	-0.087	-0.105	-0.085	0.061	0.095
20	1.099	17.48	-0.061	-0.056	-0.065	-0.061	-0.104	-0.087	-0.104	-0.085	0.061	0.095
21	1.191	18.87	-0.065	-0.059	-0.069	-0.065	-0.108	-0.090	-0.108	-0.089	0.064	0.099
22	1.377	21.65	-0.072	-0.066	-0.076	-0.072	-0.114	-0.095	-0.116	-0.095	0.072	0.105
23	1.528	23.92	-0.079	-0.072	-0.085	-0.080	-0.122	-0.103	-0.125	-0.102	0.079	0.113
24	1.665	25.98	-0.087	-0.081	-0.094	-0.090	-0.133	-0.111	-0.136	-0.111	0.088	0.123
25	1.772	27.59	-0.098	-0.093	-0.108	-0.103	-0.146	-0.125	-0.152	-0.126	0.100	0.137
26	1.841	28.61	-0.117	-0.111	-0.128	-0.123	-0.167	-0.144	-0.174	-0.146	0.120	0.158
27	1.895	29.42	-0.133	-0.128	-0.145	-0.140	-0.186	-0.163	-0.194	-0.164	0.137	0.177
28	2.026	31.40	-0.189	-0.185	-0.201	-0.197	-0.241	-0.217	-0.253	-0.220	0.193	0.232
29	2.129	32.93	-0.242	-0.238	-0.253	-0.253	-0.297	-0.269	-0.307	-0.271	0.246	0.286
30	2.192	33.89	-0.292	-0.289	-0.304	-0.303	-0.347	-0.319	-0.357	-0.319	0.297	0.335
31	2.261	34.92	-0.338	-0.336	-0.352	-0.350	-0.393	-0.366	-0.405	-0.366	0.344	0.383
32	2.295	35.42	-0.399	-0.395	-0.412	-0.412	-0.454	-0.426	-0.465	-0.427	0.404	0.443
33	2.339	36.08	-0.465	-0.462	-0.480	-0.478	-0.524	-0.494	-0.533	-0.492	0.471	0.511
34	2.354	36.30	-0.504	-0.500	-0.518	-0.518	-0.562	-0.532	-0.572	-0.530	0.510	0.549

Table C-7

TENSION TESTS ON BOLTED CONNECTIONS

SUMMARY SHEET

Test No: 8

Date: March 8, 1995

Test Designation: 3/8x1/2x3/4

Recorder: Burak Karsu

GEOMETRIC AND MATERIAL PROPERTIES

BOLT

Type: A325 Diameter $d_b = 0.75$ in. Length $L_b = 2.75$ in.

Shear Str. $F_v = 72$ ksi Edge Dist. $e = 1.5$ in. Fully Pretensioned-- No

Bolt Hole Fabr.-- Drilled

Bolt Hole Type-- Standard

Threads in Shear Plane-- X

PLATES

No	Designation	Length (in.)	Width (in.)	Thickness (in.)	Hole Dia. (in.)	Fy (ksi)	Fu (ksi)
Plate 1	PL-10	24.0	4.0	0.375	13/16	51	74
Plate 2	PL-11	24.0	5.0	0.500	13/16	54	75

TEST RESULTS

Failure Type: Bolt Shear

Failure Load: 33500 lbs/plate

Max Deflection $\Delta_{max} = 0.46$ in.

Failure Plate: N/A

COMMENTS

- * Connection slipped at a load of 9000 lbs. with a banging sound, excessive deformations occurred at that point.
- * PL-10 yielded at 19000 lbs.
- * Bolts declined and PL-11 yielded at 24500 lbs.
- * Yielding on the sides of PL-10 at 28000 lbs.
- * Bolt hole on PL-10 stretched and tips curled back at 30000 lbs.
- * Bulging on PL-10 at 31000 lbs.
- * Bolt failure at 33500 lbs.

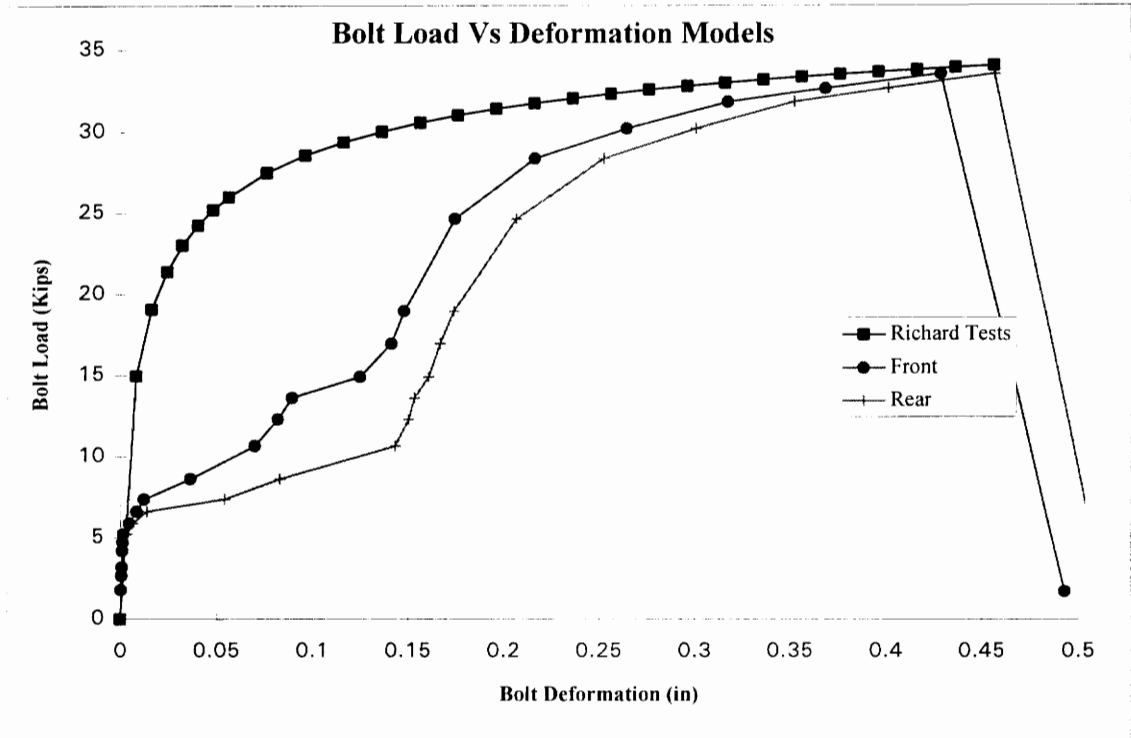

Figure C-8

Plate	tp	Fu	B/T	Bolt	A325
Plate 1	0.375	74	41.63	Bolt Dia.	0.75
Plate 2	0.5	75	56.25	Fv	72
				Bolt Shear	30.81

Richard Coefficients

$K = 12400$ $K_p = 0$ $R_o = 40$
 $K_1 = 12400$ $n = 0.5$

0	Volts	Load	F1	F2	F3	F4	R1	R2	R3	R4	AVG(F)	AVG(R)
1	0.054	1.806	0.000	0.000	-0.001	0.000	0.000	-0.001	0.000	0.000	0.000	0.000
2	0.112	2.685	0.000	-0.001	-0.001	-0.001	-0.001	-0.002	0.000	0.000	0.001	0.001
3	0.146	3.197	-0.001	-0.001	-0.001	-0.001	-0.001	-0.002	0.000	-0.001	0.001	0.001
4	0.215	4.223	-0.001	-0.001	-0.002	-0.001	-0.001	-0.004	0.000	-0.001	0.001	0.001
5	0.249	4.735	-0.001	-0.001	-0.002	-0.001	-0.002	-0.004	0.000	-0.001	0.001	0.002
6	0.283	5.248	-0.001	-0.001	-0.003	-0.001	-0.003	-0.006	-0.002	-0.002	0.002	0.003
7	0.327	5.907	-0.004	-0.004	-0.006	-0.005	-0.006	-0.010	-0.004	-0.006	0.005	0.006
8	0.376	6.640	-0.006	-0.008	-0.010	-0.010	-0.015	-0.017	-0.012	-0.012	0.008	0.014
9	0.425	7.372	-0.010	-0.012	-0.013	-0.015	-0.056	-0.055	-0.054	-0.051	0.012	0.054
10	0.508	8.617	-0.030	-0.039	-0.034	-0.042	-0.086	-0.084	-0.081	-0.080	0.036	0.083
11	0.645	10.668	-0.060	-0.075	-0.065	-0.079	-0.147	-0.144	-0.141	-0.139	0.070	0.143
12	0.752	12.279	-0.070	-0.089	-0.075	-0.093	-0.155	-0.152	-0.148	-0.145	0.082	0.150
13	0.840	13.598	-0.076	-0.099	-0.081	-0.101	-0.159	-0.155	-0.151	-0.148	0.089	0.153
14	0.928	14.916	-0.109	-0.138	-0.114	-0.138	-0.168	-0.163	-0.158	-0.153	0.125	0.161
15	1.064	16.967	-0.125	-0.153	-0.130	-0.155	-0.175	-0.171	-0.163	-0.158	0.141	0.167
16	1.197	18.953	-0.128	-0.163	-0.135	-0.166	-0.180	-0.180	-0.169	-0.166	0.148	0.174
17	1.578	24.666	-0.142	-0.196	-0.155	-0.204	-0.212	-0.222	-0.193	-0.200	0.174	0.207
18	1.826	28.393	-0.177	-0.237	-0.196	-0.255	-0.257	-0.271	-0.235	-0.246	0.216	0.252
19	1.949	30.233	-0.221	-0.286	-0.246	-0.304	-0.306	-0.323	-0.281	-0.293	0.264	0.301
20	2.056	31.844	-0.272	-0.340	-0.300	-0.359	-0.358	-0.376	-0.330	-0.344	0.317	0.352
21	2.110	32.650	-0.323	-0.390	-0.351	-0.410	-0.408	-0.427	-0.378	-0.392	0.369	0.401
22	2.169	33.529	-0.383	-0.450	-0.410	-0.470	-0.464	-0.483	-0.431	-0.447	0.429	0.456
23	0.049	1.732	-0.446	-0.515	-0.475	-0.535	-0.520	-0.542	-0.487	-0.505	0.493	0.514

Table C-8

TENSION TESTS ON BOLTED CONNECTIONS

SUMMARY SHEET

Test No: 9

Date: March 9, 1995

Test Designation: 3/8x5/8x3/4

Recorder: Burak Karsu

GEOMETRIC AND MATERIAL PROPERTIES

BOLT

Type: A325 Diameter $d_b = 0.75$ in. Length $L_b = 2.75$ in.

Shear Str. $F_v = 72$ ksi Edge Dist. $e = 1.5$ in. Fully Pretensioned-- Yes

Bolt Hole Fabr.-- Drilled

Bolt Hole Type-- Standard

Threads in Shear Plane-- X

PLATES

<u>No</u>	<u>Designation</u>	<u>Length (in.)</u>	<u>Width (in.)</u>	<u>Thickness (in.)</u>	<u>Hole Dia. (in.)</u>	<u>Fy (ksi)</u>	<u>Fu (ksi)</u>
Plate 1	PL-10	24.0	4.0	0.375	13/16	51	74
Plate 2	PL-3	24.0	5.0	0.625	13/16	45	68

TEST RESULTS

Failure Type: Bolt Shear

Failure Load: 37000 lbs.

Max Deflection $\Delta_{max} = 0.27$ in.

Failure Plate: N/A

COMMENTS

- * Yielding occurred on PL-10 at 31000 lbs.
- * PL-10 bended out of plane at 32500 lbs.
- * PL-3 yielded at 35000 lbs.
- * Yielding on sides of both PL-10 and PL-3 at 36500 lbs.
- * Bolt sheared at 37000 lbs.

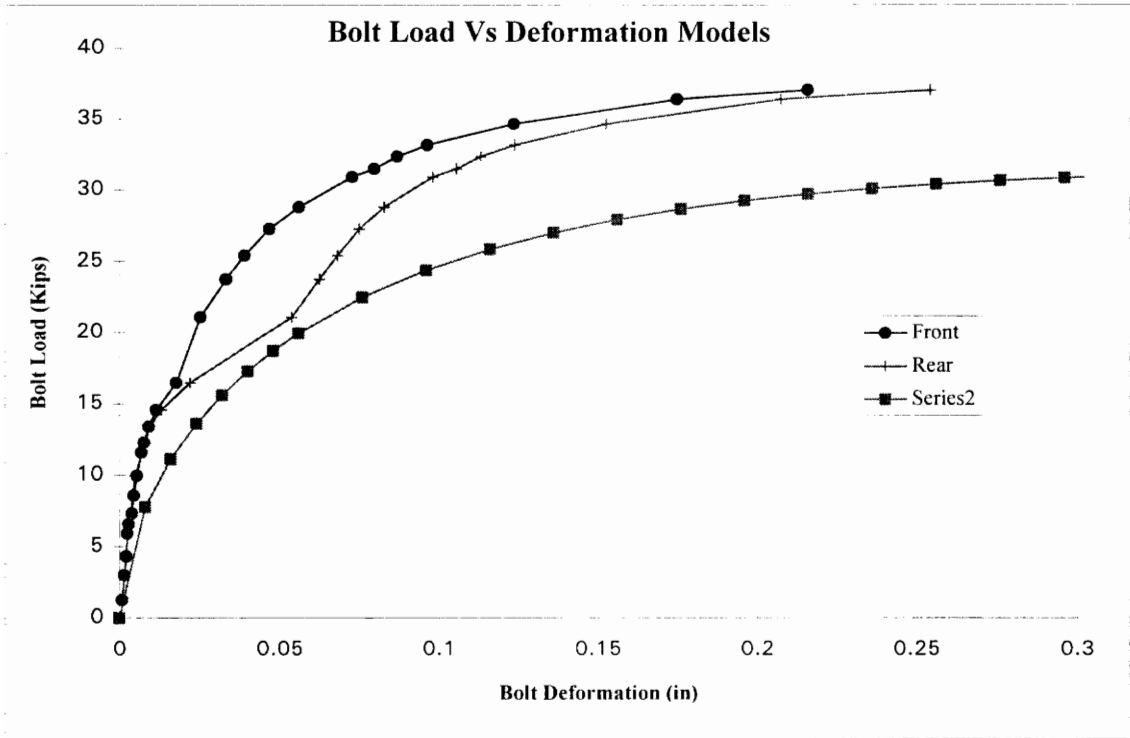

Figure C-9

Plate				Bolt		
	tp	Fu	B/T		A325	
Plate 1	0.375	74	41.63	Bolt Dia.	0.75	
Plate 2	0.625	68	63.75	Fv	72	
				Bolt Shear	30.81	

Richard Coefficients

$K = 0$ $K_p = 0$ $R_o = 0$
 $K_1 = 0$ $n = 0$

0	Volts	Load	F1	F2	F3	F4	R1	R2	R3	R4	AVG(F)	AVG(R)
1	0.083	1.25	-0.001	0.000	-0.002	-0.001	-0.002	-0.001	0.000	-0.001	0.001	0.001
2	0.200	3.00	-0.001	-0.001	-0.003	-0.002	-0.003	-0.002	0.000	-0.001	0.002	0.002
3	0.288	4.32	-0.001	-0.001	-0.004	-0.003	-0.004	-0.003	0.000	0.000	0.002	0.002
4	0.396	5.94	-0.001	0.000	-0.006	-0.004	-0.006	-0.005	0.000	-0.001	0.002	0.003
5	0.440	6.60	-0.001	0.000	-0.007	-0.004	-0.006	-0.006	0.000	-0.001	0.003	0.003
6	0.488	7.32	-0.001	-0.001	-0.008	-0.006	-0.007	-0.007	-0.001	-0.001	0.004	0.004
7	0.572	8.58	-0.001	0.000	-0.010	-0.006	-0.007	-0.007	-0.001	-0.001	0.004	0.004
8	0.665	9.97	-0.002	0.000	-0.012	-0.007	-0.008	-0.009	-0.001	-0.002	0.006	0.005
9	0.772	11.58	-0.006	-0.001	-0.015	-0.006	-0.010	-0.013	-0.002	-0.004	0.007	0.007
10	0.821	12.31	-0.007	0.000	-0.018	-0.006	-0.011	-0.015	-0.002	-0.004	0.008	0.008
11	0.894	13.41	-0.010	-0.001	-0.021	-0.005	-0.012	-0.018	-0.002	-0.006	0.009	0.009
12	0.972	14.58	-0.015	-0.001	-0.027	-0.003	-0.015	-0.023	-0.004	-0.010	0.011	0.013
13	1.099	16.49	-0.023	-0.007	-0.036	-0.006	-0.026	-0.032	-0.013	-0.018	0.018	0.022
14	1.407	21.10	-0.042	0.011	-0.061	-0.009	-0.062	-0.064	-0.044	-0.045	0.025	0.054
15	1.583	23.74	-0.053	0.008	-0.073	-0.015	-0.073	-0.074	-0.051	-0.051	0.033	0.062
16	1.583	23.74	-0.053	0.009	-0.073	-0.015	-0.073	-0.074	-0.051	-0.051	0.033	0.062
17	1.695	25.42	-0.059	0.006	-0.083	-0.020	-0.079	-0.081	-0.056	-0.056	0.039	0.068
18	1.817	27.26	-0.067	0.000	-0.092	-0.028	-0.087	-0.089	-0.061	-0.062	0.047	0.075
19	1.920	28.79	-0.076	-0.006	-0.105	-0.037	-0.095	-0.099	-0.067	-0.069	0.056	0.083
20	2.061	30.92	-0.091	-0.019	-0.126	-0.054	-0.112	-0.116	-0.081	-0.082	0.073	0.098
21	2.100	31.50	-0.098	-0.024	-0.134	-0.062	-0.120	-0.124	-0.087	-0.089	0.080	0.105
22	2.159	32.38	-0.105	-0.031	-0.142	-0.069	-0.128	-0.133	-0.094	-0.096	0.087	0.113
23	2.213	33.19	-0.113	-0.038	-0.154	-0.080	-0.140	-0.144	-0.105	-0.106	0.096	0.124
24	2.311	34.66	-0.139	-0.062	-0.185	-0.107	-0.169	-0.174	-0.132	-0.134	0.123	0.152
25	2.427	36.41	-0.190	-0.110	-0.239	-0.160	-0.226	-0.231	-0.185	-0.188	0.175	0.207
26	2.471	37.07	-0.230	-0.150	-0.282	-0.201	-0.273	-0.279	-0.231	-0.233	0.216	0.254
27	0.151	2.27	-0.359	-0.275	-0.416	-0.334	-0.407	-0.415	-0.363	-0.364	0.346	0.387
28	0.161	2.42	-0.413	-0.327	-0.471	-0.388	-0.465	-0.474	-0.421	-0.423	0.400	0.446

Table C-9

TENSION TESTS ON BOLTED CONNECTIONS

SUMMARY SHEET

Test No: 10

Date: March 10, 1995

Test Designation: 3/8x3/4x3/4

Recorder: Burak Karsu

GEOMETRIC AND MATERIAL PROPERTIES

BOLT

Type: A325 Diameter $d_b = 0.75$ in. Length $L_b = 2.75$ in.

Shear Str. $F_v = 72$ ksi Edge Dist. $e = 1.5$ in. Fully Pretensioned-- Yes

Bolt Hole Fabr.-- Drilled

Bolt Hole Type-- Standard

Threads in Shear Plane-- X

PLATES

No	Designation	Length (in.)	Width (in.)	Thickness (in.)	Hole Dia. (in.)	Fy (ksi)	Fu (ksi)
Plate 1	PL-10	24.0	4.0	0.375	13/16	51	74
Plate 2	PL-7	24.0	5.0	0.75	13/16	45	67

TEST RESULTS

Failure Type: Bolt Shear

Failure Load: 37500 lbs/plate

Max Deflection $\Delta_{max} = 0.27$ in.

Failure Plate: N/A

COMMENTS

- * Yielding started on PL-10 at 25000 lbs.
- * Yielding on the sides of PL-10 at 36000 lbs.
- * Bulging on PL-10 at 37000 lbs.
- * Bolt sheared at 37500 lbs.

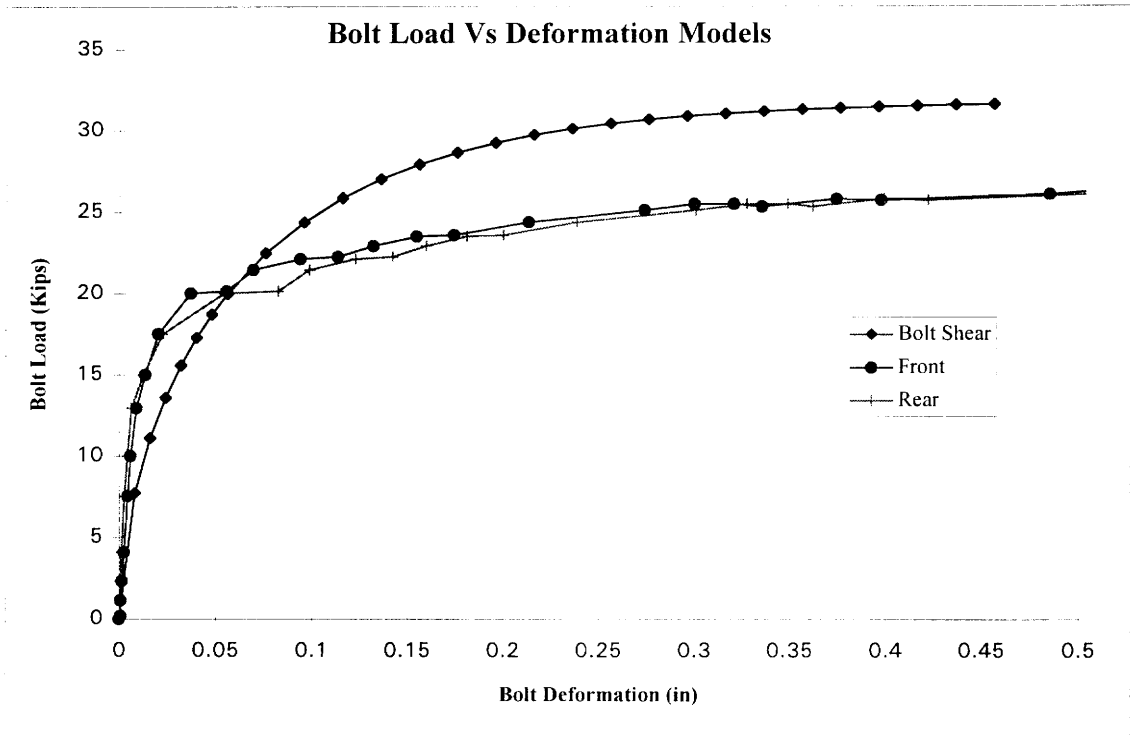

Figure C-10

Plate	tp	Fu	B/T	Bolt	A325
Plate 1	0.375	74	41.63	Bolt Dia.	0.75
Plate 2	0.75	67	75.37	Fv	72
				Bolt Shear	30.81

Richard Coefficients

K = 0 Kp = 0 Ro = 0
 K1 = 0 n = 0

Data Points	Volts	Load	F1	F2	F3	F4	R1	R2	R3	R4	AVG(F)	AVG(R)
1	0.156	2.34	-0.001	0.000	-0.001	-0.001	-0.002	-0.002	-0.001	0.000	0.001	0.001
2	0.225	3.37	-0.002	0.000	-0.002	-0.001	-0.004	-0.004	-0.001	0.000	0.001	0.002
3	0.308	4.61	-0.002	0.000	-0.002	-0.002	-0.005	-0.004	0.000	0.000	0.002	0.002
4	0.356	5.35	-0.002	0.000	-0.003	-0.002	-0.005	-0.005	0.000	0.000	0.002	0.003
5	0.420	6.30	-0.002	-0.001	-0.004	-0.003	-0.006	-0.006	-0.002	0.000	0.002	0.003
6	0.498	7.47	-0.002	-0.001	-0.004	-0.004	-0.007	-0.008	-0.002	0.000	0.002	0.004
7	0.576	8.64	-0.004	0.000	-0.005	-0.003	-0.007	-0.012	0.000	-0.002	0.003	0.005
8	0.649	9.74	-0.004	-0.001	-0.005	-0.003	-0.008	-0.015	-0.001	-0.004	0.003	0.007
9	0.742	11.13	-0.005	-0.001	-0.006	-0.003	-0.009	-0.018	0.000	-0.005	0.004	0.008
10	0.815	12.23	-0.005	-0.001	-0.007	-0.004	-0.009	-0.021	-0.001	-0.008	0.004	0.010
11	0.908	13.62	-0.006	-0.001	-0.008	-0.004	-0.008	-0.025	0.000	-0.010	0.005	0.011
12	0.996	14.94	-0.006	-0.001	-0.009	-0.005	-0.007	-0.029	-0.001	-0.014	0.005	0.013
13	1.060	15.90	-0.006	-0.001	-0.011	-0.006	-0.006	-0.034	0.001	-0.017	0.006	0.014
14	1.118	16.77	-0.007	-0.001	-0.012	-0.006	-0.005	-0.037	0.002	-0.020	0.006	0.015
15	1.221	18.32	-0.009	-0.001	-0.014	-0.006	-0.004	-0.045	0.005	-0.026	0.008	0.017
16	1.348	20.22	-0.015	-0.002	-0.020	-0.007	-0.004	-0.053	0.006	-0.033	0.011	0.021
17	1.465	21.98	-0.020	-0.003	-0.026	-0.009	-0.005	-0.059	0.007	-0.038	0.014	0.024
18	1.568	23.52	-0.023	-0.004	-0.030	-0.010	-0.007	-0.064	0.006	-0.043	0.017	0.027
19	1.666	24.98	-0.027	-0.006	-0.035	-0.013	-0.009	-0.071	0.005	-0.048	0.020	0.031
20	1.789	26.83	-0.032	-0.009	-0.042	-0.018	-0.013	-0.081	0.002	-0.056	0.025	0.037
21	1.877	28.15	-0.037	-0.012	-0.046	-0.021	-0.020	-0.090	-0.001	-0.064	0.029	0.043
22	1.970	29.54	-0.041	-0.015	-0.051	-0.026	-0.027	-0.101	-0.007	-0.073	0.033	0.052
23	2.092	31.38	-0.049	-0.023	-0.061	-0.034	-0.043	-0.121	-0.018	-0.089	0.042	0.068
24	2.189	32.84	-0.065	-0.040	-0.078	-0.051	-0.065	-0.146	-0.037	-0.111	0.058	0.090
25	2.297	34.45	-0.091	-0.066	-0.105	-0.080	-0.095	-0.179	-0.064	-0.141	0.085	0.120
26	2.414	36.21	-0.142	-0.117	-0.159	-0.133	-0.153	-0.238	-0.118	-0.198	0.138	0.177
27	2.502	37.53	-0.202	-0.177	-0.221	-0.194	-0.214	-0.300	-0.177	-0.260	0.198	0.238
28	0.563	8.44	-0.253	-4.907	-0.271	-0.227	-0.405	-0.462	-0.496	-0.543	1.415	0.477

Table C-10

TENSION TESTS ON BOLTED CONNECTIONS

SUMMARY SHEET

Test No: 12

Date: March 12, 1995

Test Designation: 1/8x1/8x3/4

Recorder: Burak Karsu

GEOMETRIC AND MATERIAL PROPERTIES

BOLT

Type:A325 Diameter $d_b=0.750$ in. Length $L_b=1.75$ in.

Shear Str. $F_v=72$ ksi Edge Dist. $e=1.5$ in Fully Pretensioned--Yes

Bolt Hole Fabr.--Drilled Bolt Hole Type--Standard

Threads in Shear Plane--X

PLATES

No	Designation	Length (in.)	Width (in.)	Thickness (in.)	Hole Dia. (in.)	Fy (ksi)	Fu (ksi)
Plate 1	PL-17	24	6	0.125	14/16	44	62
Plate 2	PL-17	24	6	0.125	14/16	44	62

TEST RESULTS

Failure Type: Splitting

Failure Load:12500 lbs/plate

Max Deflection $\Delta_{max}=1.0$ in.

Failure Plate:PL-17

COMMENTS

- * Bolts declined at 5000 lbs.
- *Bolt holes elongated at 6000 lbs.
- *Tips of the plate curled back at 7000 lbs.
- *Tension tearing at 12500 lbs.

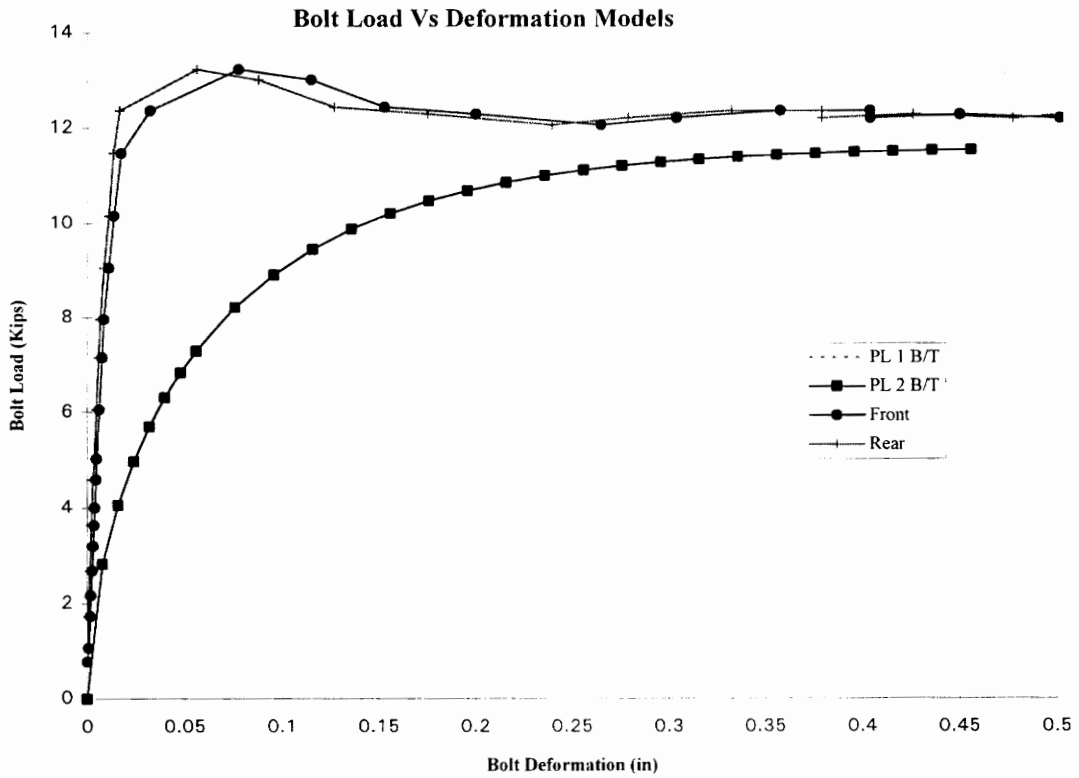

Figure C-12

Plate			Bolt		
	tp	Fu	B/T	Bolt Dia.	A325 0.75
Plate 1	0.125	62	11.63	Fv	72
Plate 2	0.125	62	11.63	Bolt Shear	30.8

Richard Coefficients

K= 0 Kp= 0 Ro= 0
 K1= 0 n= 0

Data Point	Volts	Load	F1	F2	F3	F4	R1	R2	R3	R4	AVG(F)	AVG(R)
1	0.03	0.79	-0.001	0.000	0.000	0.000	0.000	-0.001	0.000	0.000	0.000	0.000
2	0.05	1.07	-0.002	-0.001	-0.001	0.000	-0.001	-0.001	0.000	0.000	0.001	0.000
3	0.10	1.74	-0.002	-0.003	-0.001	-0.001	-0.001	-0.001	0.000	0.000	0.002	0.000
4	0.13	2.18	-0.003	-0.003	-0.001	-0.001	-0.002	-0.001	-0.001	-0.001	0.002	0.001
5	0.16	2.69	-0.004	-0.004	-0.002	-0.001	-0.003	-0.001	-0.001	-0.001	0.003	0.002
6	0.19	3.20	-0.006	-0.004	-0.002	-0.001	-0.004	-0.002	-0.002	-0.001	0.003	0.002
7	0.22	3.64	-0.006	-0.005	-0.003	-0.001	-0.004	-0.002	-0.002	-0.001	0.004	0.002
8	0.25	4.01	-0.006	-0.006	-0.004	-0.001	-0.005	-0.002	-0.002	-0.001	0.004	0.002
9	0.29	4.59	-0.006	-0.007	-0.004	-0.001	-0.006	-0.002	-0.003	-0.001	0.005	0.003
10	0.31	5.02	-0.007	-0.007	-0.004	-0.002	-0.007	-0.002	-0.005	-0.001	0.005	0.004
11	0.38	6.06	-0.007	-0.009	-0.006	-0.004	-0.009	-0.003	-0.006	-0.001	0.006	0.005
12	0.46	7.16	-0.009	-0.010	-0.007	-0.005	-0.010	-0.004	-0.007	-0.002	0.008	0.006
13	0.51	7.96	-0.010	-0.012	-0.007	-0.006	-0.011	-0.005	-0.008	-0.004	0.009	0.007
14	0.58	9.06	-0.012	-0.014	-0.009	-0.009	-0.013	-0.007	-0.010	-0.005	0.011	0.009
15	0.66	10.16	-0.015	-0.017	-0.012	-0.012	-0.015	-0.010	-0.012	-0.008	0.014	0.011
16	0.75	11.48	-0.018	-0.020	-0.015	-0.017	-0.016	-0.013	-0.014	-0.010	0.017	0.013
17	0.80	12.36	-0.029	-0.038	-0.029	-0.032	-0.018	-0.017	-0.017	-0.015	0.032	0.017
18	0.86	13.24	-0.073	-0.084	-0.074	-0.080	-0.059	-0.054	-0.059	-0.052	0.078	0.056
19	0.85	13.02	-0.109	-0.121	-0.113	-0.118	-0.091	-0.086	-0.091	-0.084	0.115	0.088
20	0.81	12.43	-0.147	-0.160	-0.150	-0.155	-0.130	-0.125	-0.131	-0.122	0.153	0.127
21	0.80	12.28	-0.194	-0.208	-0.196	-0.203	-0.177	-0.174	-0.179	-0.171	0.200	0.175
22	0.78	12.06	-0.259	-0.274	-0.259	-0.268	-0.241	-0.239	-0.243	-0.236	0.265	0.240
23	0.79	12.21	-0.298	-0.314	-0.298	-0.307	-0.280	-0.279	-0.281	-0.276	0.304	0.279
24	0.80	12.36	-0.353	-0.368	-0.350	-0.361	-0.334	-0.333	-0.336	-0.328	0.358	0.333
25	0.80	12.36	-0.398	-0.414	-0.397	-0.408	-0.381	-0.379	-0.381	-0.376	0.404	0.379
26	0.79	12.21	-0.398	-0.414	-0.397	-0.408	-0.381	-0.379	-0.381	-0.376	0.404	0.379
27	0.80	12.28	-0.443	-0.461	-0.443	-0.454	-0.427	-0.426	-0.429	-0.423	0.450	0.426
28	0.79	12.21	-0.495	-0.512	-0.494	-0.505	-0.479	-0.478	-0.481	-0.473	0.501	0.478
29	0.80	12.36	-0.547	-0.565	-0.546	-0.557	-0.531	-0.531	-0.534	-0.525	0.554	0.530
30	0.79	12.21	-0.597	-0.615	-0.596	-0.610	-0.580	-0.582	-0.584	-0.576	0.605	0.581
31	0.82	12.58	-0.647	-0.664	-0.646	-0.659	-0.629	-0.630	-0.633	-0.626	0.654	0.630
32	0.82	12.65	-0.695	-0.712	-0.694	-0.707	-0.679	-0.678	-0.682	-0.674	0.702	0.678
33	0.84	12.87	-0.801	-0.818	-0.800	-0.814	-0.784	-0.786	-0.790	-0.782	0.808	0.785
34	0.85	13.09	-0.857	-0.872	-0.854	-0.869	-0.837	-0.841	-0.844	-0.836	0.863	0.840
35	0.87	13.31	-0.928	-0.948	-0.928	-0.944	-0.914	-0.916	-0.921	-0.911	0.937	0.916
36	0.83	12.72	-0.993	-1.012	-0.991	-1.008	-0.991	-0.993	-1.000	-0.989	1.001	0.993
37	0.82	12.65	-1.045	-1.066	-1.045	-1.062	-1.048	-1.051	-1.058	-1.047	1.055	1.051

Table C-12

TENSION TESTS ON BOLTED CONNECTIONS

SUMMARY SHEET

Test No: 13

Date: March 12, 1995

Test Designation: 1/8x1/4x3/4

Recorder: Burak Karsu

GEOMETRIC AND MATERIAL PROPERTIES

BOLT

Type:A325

Diameter $d_b=0.75$ in.

Length $L_b=2.0$ in.

Shear Str. $F_v=72$ ksi

Edge Dist. $e=1.5$ in.

Fully Pretensioned--Yes

Bolt Hole Fabr.--Drilled

Bolt Hole Type--Standard

Threads in Shear Plane--X

PLATES

<u>No</u>	<u>Designation</u>	<u>Length (in.)</u>	<u>Width (in.)</u>	<u>Thickness (in.)</u>	<u>Hole Dia. (in.)</u>	<u>Fy (ksi)</u>	<u>Fu (ksi)</u>
Plate 1	PL-15	24.0	5.0	0.125	14/16	43.3	61.4
Plate 2	PL-18	24.0	4.0	0.25	14/16	47.5	66.7

TEST RESULTS

Failure Type: Splitting

Failure Load: 15000 lbs/plate

Max Deflection $\Delta_{max}=0.75$ in.

Failure Plate: PL-15

COMMENTS

* Yielding on PL-15 started at 14000 lbs.

* After 16000 lbs, load decreases.

* PL-18 yields at 15000 lbs.

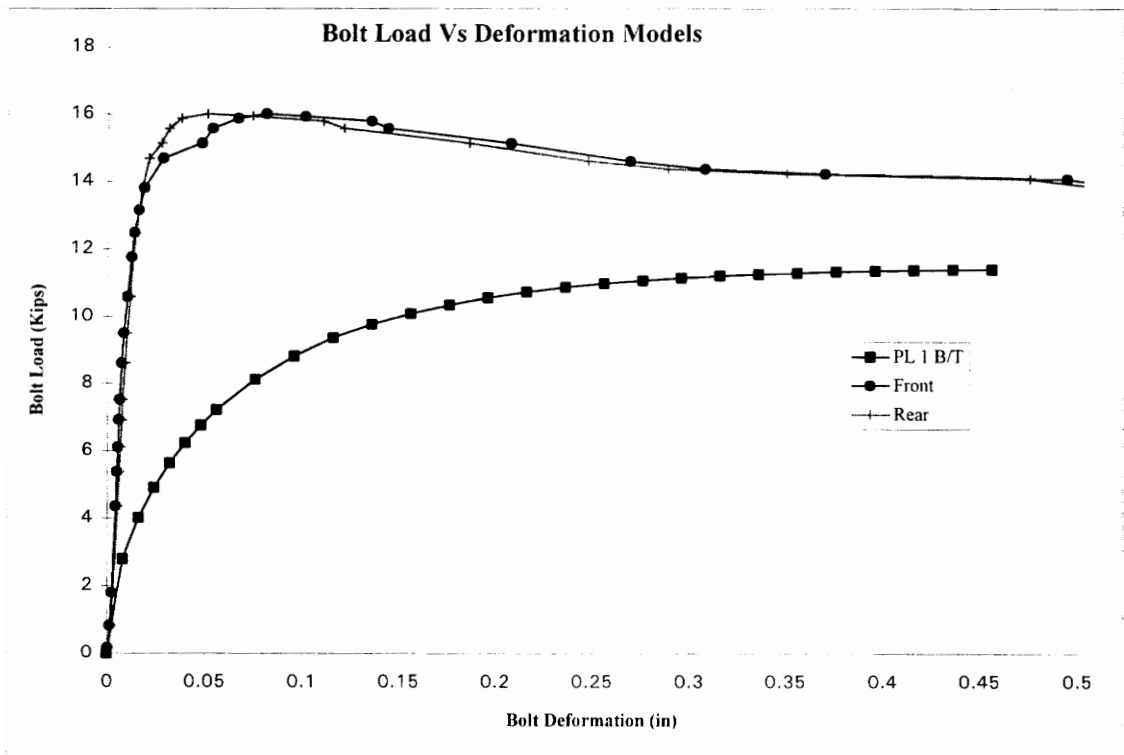

Figure C-13

Plate				Bolt		A325
	tp	Fu	B/T	Bolt Dia.	Fv	
Plate 1	0.125	61.4	11.49		72	
Plate 2	0.25	66.7	25.01	Bolt Shear	30.8	

Richard Coefficients

$K = 0$ $K_p = 0$ $R_o = 0$
 $K_1 = 0$ $n = 0$

Data Point	Volts	Load	F1	F2	F3	F4	R1	R2	R3	R4	AVG(F)	AVG(R)
1	0.00	0.19	-0.001	0.000	0.000	-0.001	0.000	0.000	0.000	0.000	0.000	0.000
2	0.04	0.85	-0.001	-0.001	-0.002	-0.002	-0.003	-0.002	-0.001	-0.001	0.002	0.002
3	0.11	1.80	0.000	0.001	-0.006	-0.004	-0.007	-0.006	0.000	0.000	0.002	0.003
4	0.28	4.36	0.000	0.002	-0.010	-0.009	-0.013	-0.010	0.001	0.001	0.004	0.005
5	0.35	5.39	0.000	0.002	-0.012	-0.010	-0.014	-0.012	0.001	0.001	0.005	0.006
6	0.40	6.12	0.000	0.002	-0.013	-0.010	-0.015	-0.013	0.001	0.001	0.006	0.007
7	0.45	6.93	-0.001	0.002	-0.015	-0.011	-0.016	-0.016	0.001	0.001	0.006	0.007
8	0.49	7.51	-0.001	0.002	-0.015	-0.012	-0.016	-0.017	0.002	0.000	0.006	0.008
9	0.56	8.61	-0.003	0.003	-0.018	-0.012	-0.018	-0.020	0.002	-0.002	0.007	0.009
10	0.62	9.49	-0.004	0.003	-0.020	-0.013	-0.018	-0.023	0.004	-0.004	0.008	0.010
11	0.69	10.59	-0.007	0.004	-0.024	-0.013	-0.018	-0.027	0.004	-0.006	0.010	0.012
12	0.77	11.76	-0.010	0.004	-0.029	-0.015	-0.018	-0.031	0.006	-0.009	0.012	0.013
13	0.82	12.49	-0.012	0.004	-0.032	-0.015	-0.019	-0.034	0.006	-0.012	0.014	0.015
14	0.86	13.15	-0.015	0.004	-0.037	-0.017	-0.020	-0.037	0.007	-0.014	0.016	0.016
15	0.91	13.81	-0.019	0.003	-0.041	-0.018	-0.020	-0.040	0.007	-0.018	0.019	0.018
16	0.97	14.69	-0.028	-0.006	-0.051	-0.029	-0.020	-0.047	0.007	-0.025	0.028	0.021
17	1.00	15.13	-0.047	-0.026	-0.070	-0.050	-0.021	-0.059	0.007	-0.037	0.048	0.028
18	1.03	15.57	-0.052	-0.031	-0.076	-0.055	-0.023	-0.065	0.005	-0.043	0.054	0.031
19	1.05	15.87	-0.065	-0.045	-0.089	-0.069	-0.028	-0.073	0.001	-0.050	0.067	0.038
20	1.05	16.01	-0.080	-0.059	-0.104	-0.083	-0.041	-0.086	-0.013	-0.064	0.081	0.051
21	1.05	15.94	-0.100	-0.078	-0.125	-0.103	-0.065	-0.110	-0.037	-0.086	0.101	0.074
22	1.04	15.79	-0.133	-0.112	-0.160	-0.138	-0.101	-0.146	-0.073	-0.123	0.136	0.111
23	1.03	15.57	-0.142	-0.120	-0.168	-0.146	-0.112	-0.157	-0.084	-0.132	0.144	0.121
24	1.00	15.13	-0.206	-0.182	-0.233	-0.209	-0.178	-0.221	-0.149	-0.196	0.208	0.186
25	0.96	14.62	-0.268	-0.244	-0.295	-0.271	-0.238	-0.284	-0.210	-0.258	0.269	0.248
26	0.95	14.40	-0.306	-0.282	-0.335	-0.309	-0.277	-0.333	-0.249	-0.296	0.308	0.289
27	0.94	14.25	-0.368	-0.343	-0.399	-0.371	-0.340	-0.393	-0.311	-0.357	0.370	0.350
28	0.93	14.11	-0.490	-0.466	-0.525	-0.497	-0.467	-0.513	-0.437	-0.484	0.495	0.475
29	0.89	13.59	-0.557	-0.530	-0.592	-0.563	-0.543	-0.587	-0.511	-0.557	0.560	0.549

Table C-13

TENSION TESTS ON BOLTED CONNECTIONS

SUMMARY SHEET

Test No: 14

Date: March 13, 1995

Test Designation: 1/8x3/8x3/4

Recorder: Burak Karsu

GEOMETRIC AND MATERIAL PROPERTIES

BOLT

Type:A325 Diameter $d_b=0.75$ in. Length $L_b=1.75$ in.

Shear Str. $F_v=72$ ksi Edge Dist. $e=1.5$ in. Fully Pretensioned--Yes

Bolt Hole Fabr.--Drilled

Bolt Hole Type--Standard

Threads in Shear Plane--X

PLATES

<u>No</u>	<u>Designation</u>	<u>Length</u> <u>(in.)</u>	<u>Width</u> <u>(in.)</u>	<u>Thickness</u> <u>(in.)</u>	<u>Hole Dia.</u> <u>(in.)</u>	<u>Fy</u> <u>(ksi)</u>	<u>Fu</u> <u>(ksi)</u>
Plate 1	PL-17	24.0	5.0	0.125	14/16	44.1	62.0
Plate 2	PL-21	24.0	4.0	0.375	14/16	43.4	63.7

TEST RESULTS

Failure Type: Bearing / Tear out

Failure Load: 16330 lbs/plate

Max Deflection $\Delta_{max}=0.75$ in.

Failure Plate: PL-17

COMMENTS

- * Yielding on PL-17 started at 13500 lbs and .02 in.
- * Bulging on PL-17 started at 16000 lbs and .04 in.
- * Load decreases at 16500 lbs at .08 in.
- * Cracks formed at the tip of the plate at 0.2 in.

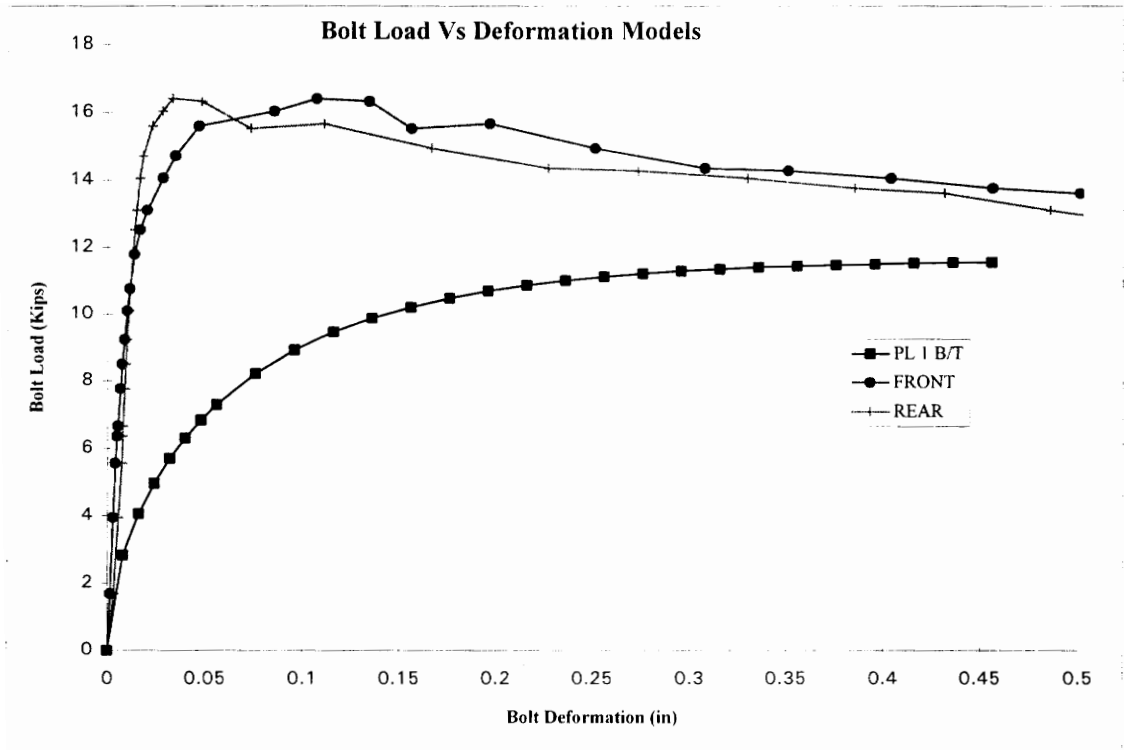

Figure C-14

Plate	tp	Fu	B/T	Bolt	A325
Plate 1	0.125	62	11.63	Bolt Dia.	0.75
Plate 2	0.375	63.7	35.83	Fv	72
				Bolt Shear	30.8

Richard Coefficients

K= 0 Kp= 0 Ro= 0
 K1= 0 n= 0

Data Point	Volts	Load	F1	F2	F3	F4	R1	R2	R3	R4	AVG(F)	AVG(R)
1	0.00	0.00	-0.001	0.000	0.000	0.000	0.000	0.000	0.000	-0.001	0.000	0.000
2	0.11	1.68	0.000	-0.001	-0.003	-0.002	-0.007	-0.006	0.000	0.000	0.002	0.003
3	0.26	3.96	-0.001	0.000	-0.006	-0.006	-0.014	-0.012	0.001	0.002	0.003	0.006
4	0.37	5.57	-0.001	-0.001	-0.008	-0.007	-0.019	-0.017	0.002	0.004	0.004	0.007
5	0.42	6.37	-0.001	-0.001	-0.010	-0.009	-0.020	-0.017	0.001	0.004	0.005	0.008
6	0.44	6.67	0.000	-0.001	-0.010	-0.011	-0.021	-0.017	0.001	0.006	0.006	0.008
7	0.52	7.76	0.000	-0.002	-0.012	-0.013	-0.026	-0.018	0.000	0.007	0.007	0.009
8	0.57	8.50	0.000	-0.002	-0.013	-0.015	-0.028	-0.018	0.000	0.008	0.008	0.009
9	0.62	9.23	-0.001	-0.003	-0.015	-0.017	-0.030	-0.018	-0.001	0.009	0.009	0.010
10	0.67	10.11	-0.001	-0.004	-0.016	-0.020	-0.033	-0.019	-0.002	0.010	0.010	0.011
11	0.72	10.77	-0.001	-0.005	-0.018	-0.022	-0.036	-0.019	-0.002	0.011	0.011	0.012
12	0.79	11.79	-0.002	-0.007	-0.021	-0.025	-0.040	-0.021	-0.004	0.012	0.014	0.013
13	0.83	12.52	-0.006	-0.009	-0.024	-0.029	-0.043	-0.021	-0.006	0.013	0.017	0.014
14	0.87	13.11	-0.008	-0.012	-0.028	-0.033	-0.046	-0.021	-0.007	0.014	0.020	0.015
15	0.94	14.06	-0.015	-0.020	-0.036	-0.043	-0.050	-0.022	-0.009	0.015	0.028	0.017
16	0.98	14.72	-0.021	-0.026	-0.043	-0.050	-0.054	-0.023	-0.011	0.015	0.035	0.018
17	1.04	15.60	-0.032	-0.039	-0.054	-0.063	-0.060	-0.025	-0.015	0.008	0.047	0.023
18	1.07	16.04	-0.070	-0.079	-0.092	-0.101	-0.070	-0.029	-0.021	0.007	0.085	0.028
19	1.09	16.41	-0.092	-0.101	-0.114	-0.122	-0.078	-0.033	-0.028	0.006	0.107	0.033
20	1.09	16.33	-0.120	-0.128	-0.142	-0.149	-0.095	-0.048	-0.043	-0.007	0.135	0.048
21	1.04	15.53	-0.142	-0.149	-0.164	-0.171	-0.120	-0.072	-0.069	-0.032	0.156	0.073
22	1.04	15.67	-0.183	-0.189	-0.205	-0.211	-0.158	-0.111	-0.107	-0.069	0.197	0.111
23	1.00	14.94	-0.237	-0.243	-0.260	-0.266	-0.214	-0.167	-0.162	-0.124	0.252	0.167
24	0.96	14.36	-0.292	-0.301	-0.317	-0.323	-0.275	-0.228	-0.222	-0.184	0.308	0.227
25	0.95	14.28	-0.336	-0.344	-0.361	-0.365	-0.321	-0.275	-0.268	-0.231	0.352	0.274
26	0.94	14.06	-0.388	-0.396	-0.416	-0.418	-0.376	-0.331	-0.325	-0.289	0.404	0.330
27	0.92	13.77	-0.439	-0.447	-0.468	-0.472	-0.430	-0.386	-0.381	-0.345	0.457	0.386
28	0.91	13.62	-0.482	-0.492	-0.514	-0.517	-0.475	-0.432	0.000	-0.392	0.501	0.325
29	0.87	13.11	-0.537	-0.548	-0.570	-0.572	-0.528	-0.486	-0.483	-0.447	0.557	0.486
30	0.83	12.38	-0.638	-0.647	-0.667	-0.668	-0.619	-0.577	-0.575	-0.538	0.655	0.577
32	0.72	10.84	-0.739	-0.746	-0.768	-0.761	-0.692	-0.652	-0.647	-0.615	0.754	0.651
33	0.70	10.47	-0.743	-0.749	-0.771	-0.764	-0.695	-0.655	-0.651	-0.619	0.757	0.655

Table C-14

TENSION TESTS ON BOLTED CONNECTIONS

SUMMARY SHEET

Test No: 15

Date: March 13, 1995

Test Designation: 1/8x1/2x3/4

Recorder: Burak Karsu

GEOMETRIC AND MATERIAL PROPERTIES

BOLT

Type: A325

Diameter $d_b=0.75$

Length $L_b=2$ in.

Shear Str. $F_v=72$ ksi

Edge Dist. $e=1.5$ in.

Fully Pretensioned--Yes

Bolt Hole Fabr.--Drilled

Bolt Hole Type--Standard

Threads in Shear Plane--X

PLATES

No	Designation	Length (in.)	Width (in.)	Thickness (in.)	Hole Dia. (in.)	Fy (ksi)	Fu (ksi)
Plate 1	PL-15	24.0	5.0	0.125	14/16	43.3	61.4
Plate 2	PL-12	24.0	4.0	0.5	14/16	51.5	74.5

TEST RESULTS

Failure Type: Bearing / Tear Out

Failure Load: 17200 lbs/plate

Max Deflection $\Delta_{max}=0.45$ in.

Failure Plate: PL-15

COMMENTS

- * Yielding started at 13500 lbs and .013 in.
- * Bulging on PL-17 started at .03 in. and 17000 lbs.
- * Load decreased after 17250 lbs.
- * Splitting observed at 0.13 in.

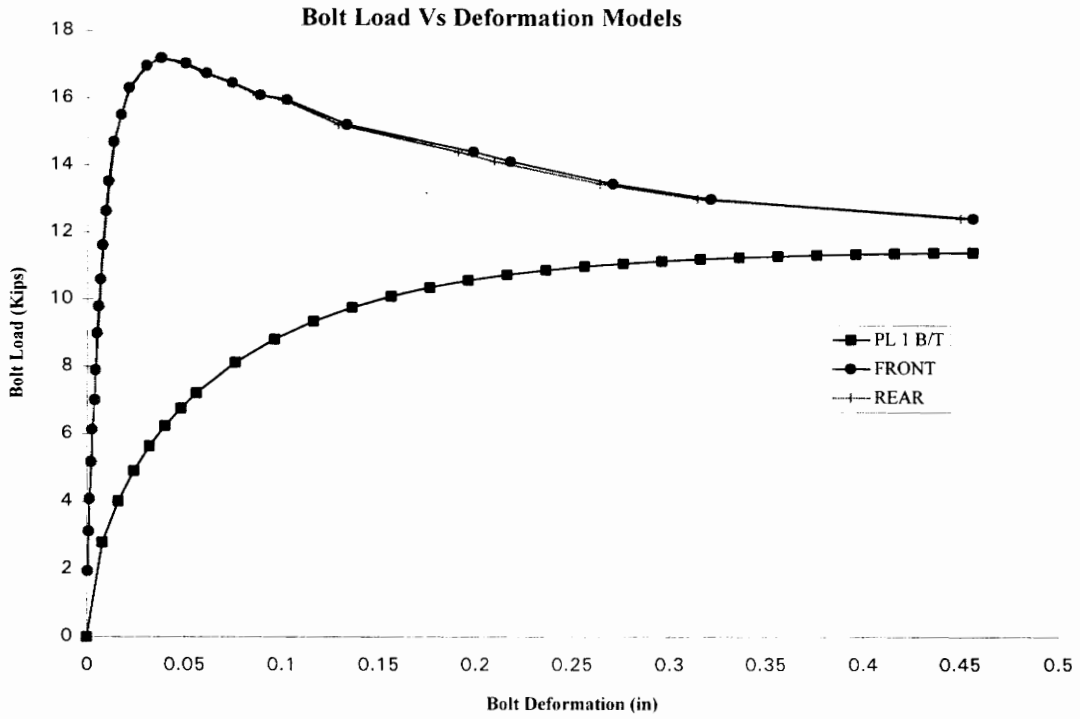

Figure C-15

Plate				Bolt		A325
	tp	Fu	B/T	Bolt Dia.		
Plate 1	0.125	61.3	11.49	Fv		72
Plate 2	0.5	74.5	55.88	Bolt Shear		30.8

Richard Coefficients

$K = 0$ $K_p = 0$ $R_o = 0$
 $K_1 = 0$ $n = 0$

Data Point	Volts	Load	F1	F2	F3	F4	R1	R2	R3	R4	AVG(F)	AVG(R)
1	0.04	1.95	-0.001	0.000	-0.001	0.000	-0.002	-0.001	0.000	0.000	0.000	0.001
2	0.12	3.13	-0.001	0.000	-0.002	-0.001	-0.004	-0.003	0.001	0.002	0.001	0.001
3	0.19	4.08	-0.002	0.000	-0.002	-0.001	-0.005	-0.004	0.001	0.002	0.001	0.002
4	0.26	5.18	-0.002	0.000	-0.004	-0.002	-0.008	-0.006	0.001	0.003	0.002	0.002
5	0.32	6.13	-0.002	0.000	-0.006	-0.002	-0.009	-0.007	0.001	0.003	0.003	0.003
6	0.38	7.01	-0.004	-0.001	-0.007	-0.004	-0.010	-0.008	0.000	0.003	0.004	0.004
7	0.44	7.89	-0.004	-0.001	-0.008	-0.004	-0.012	-0.009	0.000	0.004	0.004	0.004
8	0.51	8.99	-0.006	0.000	-0.010	-0.005	-0.015	-0.010	-0.001	0.004	0.005	0.006
9	0.57	9.80	-0.006	0.000	-0.011	-0.006	-0.017	-0.012	-0.001	0.004	0.006	0.006
10	0.62	10.60	-0.007	0.001	-0.013	-0.007	-0.018	-0.013	-0.002	0.004	0.007	0.007
11	0.69	11.63	-0.008	0.001	-0.015	-0.009	-0.020	-0.014	-0.003	0.004	0.008	0.008
12	0.76	12.65	-0.010	0.000	-0.018	-0.010	-0.023	-0.016	-0.004	0.004	0.009	0.010
13	0.82	13.53	-0.012	0.000	-0.020	-0.011	-0.026	-0.018	-0.006	0.004	0.011	0.011
14	0.89	14.70	-0.015	-0.002	-0.024	-0.013	-0.029	-0.020	-0.009	0.002	0.013	0.014
15	0.95	15.51	-0.019	-0.005	-0.029	-0.017	-0.034	-0.023	-0.012	0.000	0.017	0.017
16	1.00	16.31	-0.023	-0.008	-0.034	-0.020	-0.040	-0.028	-0.017	-0.003	0.021	0.022
17	1.04	16.97	-0.032	-0.015	-0.043	-0.029	-0.050	-0.035	-0.026	-0.010	0.030	0.030
18	1.06	17.19	-0.040	-0.023	-0.051	-0.036	-0.056	-0.042	-0.032	-0.017	0.038	0.037
19	1.05	17.05	-0.053	-0.035	-0.064	-0.050	-0.068	-0.053	-0.044	-0.028	0.050	0.048
20	1.03	16.75	-0.063	-0.046	-0.075	-0.060	-0.079	-0.065	-0.055	-0.039	0.061	0.060
21	1.01	16.46	-0.076	-0.059	-0.087	-0.073	-0.092	-0.078	-0.069	-0.053	0.074	0.073
22	0.99	16.09	-0.091	-0.074	-0.101	-0.088	-0.106	-0.092	-0.083	-0.067	0.089	0.087
23	0.98	15.95	-0.104	-0.088	-0.115	-0.102	-0.119	-0.106	-0.097	-0.080	0.102	0.100
24	0.93	15.22	-0.135	-0.119	-0.146	-0.133	-0.147	-0.135	-0.126	-0.107	0.133	0.129
25	0.87	14.41	-0.200	-0.185	-0.210	-0.200	-0.208	-0.196	-0.188	-0.169	0.199	0.191
26	0.85	14.12	-0.220	-0.204	-0.229	-0.219	-0.227	-0.215	-0.207	-0.188	0.218	0.209
27	0.81	13.46	-0.271	-0.257	-0.282	-0.272	-0.283	-0.269	-0.261	-0.243	0.271	0.264
28	0.78	13.02	-0.322	-0.308	-0.333	-0.324	-0.334	-0.321	-0.311	-0.293	0.321	0.315
29	0.74	12.43	-0.455	-0.443	-0.468	-0.459	-0.470	-0.456	-0.447	-0.427	0.456	0.450

Table C-15

TENSION TESTS ON BOLTED CONNECTIONS

SUMMARY SHEET

Test No: 16

Date: March 14, 1995

Test Designation: 1/8x5/8x3/4

Recorder: Burak Karsu

GEOMETRIC AND MATERIAL PROPERTIES

BOLT

Type: A325

Diameter $d_b=0.75$

Length $L_b=$

Shear Str. $F_v=72$ ksi

Edge Dist. $e=1.5$ in.

Fully Pretensioned--Yes

Bolt Hole Fabr.--Drilled

Bolt Hole Type--Standard

Threads in Shear Plane--X

PLATES

No	Designation	Length (in.)	Width (in.)	Thickness (in.)	Hole Dia. (in.)	Fy (ksi)	Fu (ksi)
Plate 1	PL-17	24.0	5.0	0.125	14/16	44.1	62.0
Plate 2	PL-27	24.0	4.0	0.625	14/16	45.8	68.1

TEST RESULTS

Failure Type: Splitting

Failure Load: 15200 lbs/plate

Max Deflection $\Delta_{max}=0.59$ in.

Failure Plate: PL 17

COMMENTS

- * Yielding on PL-17 started at 13500 lbs and 0.02 in.
- * At 14500 lbs, bulging on PL-17 was observed.
- * After 15500 lbs, load decreased.
- * Splitting seen at 0.11 in.

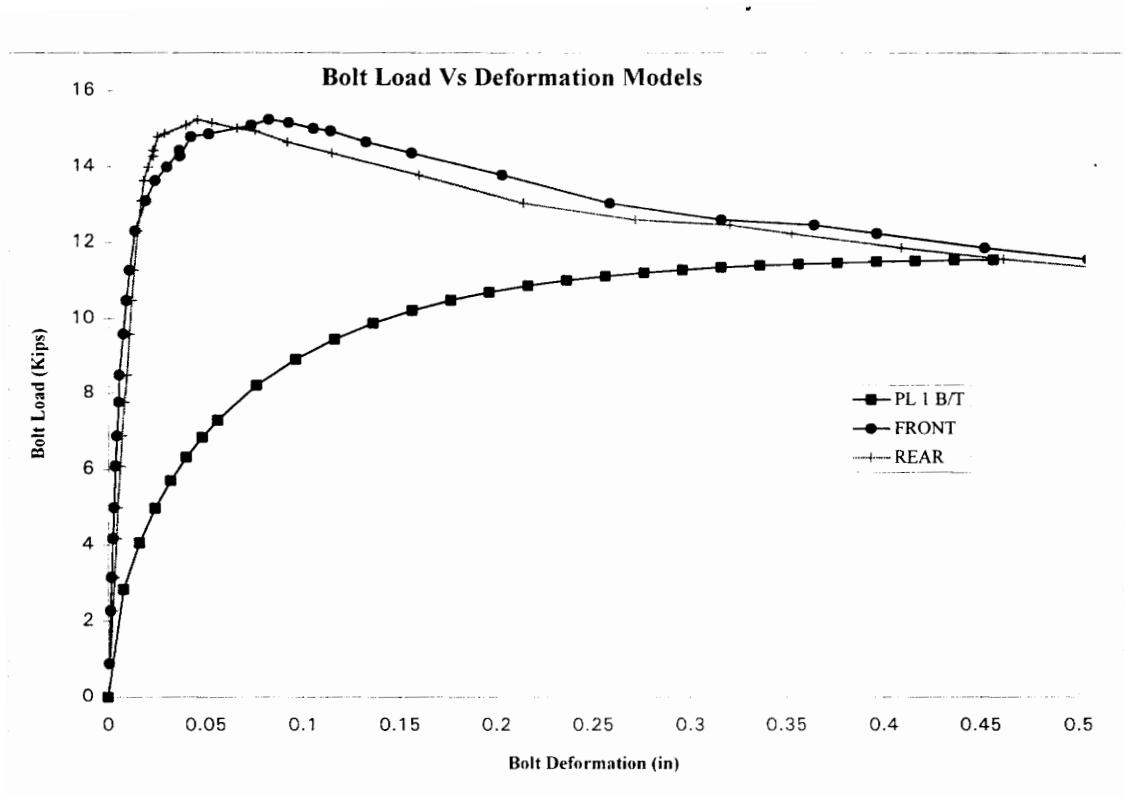

Figure C-16

Plate				Bolt	A325
	tp	Fu	B/T	Bolt Dia.	0.75
Plate 1	0.125	62	11.63	Fv	72
Plate 2	0.625	68.1	63.94	Bolt Shear	30.8

Richard Coefficients

K= 0 Kp= 0 Ro= 0
 K1= 0 n= 0

Data Point	Volts	Load	F1	F2	F3	F4	R1	R2	R3	R4	AVG(F)	AVG(R)
1	0.06	0.88	0.000	0.000	-0.002	-0.001	-0.002	-0.002	0.000	0.001	0.001	0.001
2	0.15	2.27	-0.001	0.000	-0.003	-0.002	-0.006	-0.006	0.001	0.001	0.001	0.002
3	0.21	3.15	-0.001	0.000	-0.004	-0.002	-0.009	-0.007	0.001	0.002	0.002	0.003
4	0.28	4.17	-0.001	0.000	-0.005	-0.004	-0.010	-0.010	0.001	0.002	0.002	0.004
5	0.33	4.98	-0.001	0.000	-0.006	-0.006	-0.013	-0.011	0.002	0.003	0.003	0.005
6	0.41	6.08	-0.001	0.000	-0.008	-0.006	-0.016	-0.014	0.002	0.004	0.004	0.006
7	0.46	6.88	-0.001	0.000	-0.009	-0.007	-0.018	-0.017	0.002	0.004	0.004	0.007
8	0.52	7.76	-0.002	0.000	-0.010	-0.009	-0.021	-0.018	0.002	0.005	0.005	0.008
9	0.57	8.50	-0.004	0.000	-0.011	-0.007	-0.023	-0.023	0.004	0.004	0.006	0.009
10	0.64	9.59	-0.006	0.001	-0.015	-0.009	-0.025	-0.026	0.006	0.003	0.007	0.011
11	0.70	10.47	-0.008	0.001	-0.018	-0.011	-0.027	-0.029	0.007	0.002	0.009	0.012
12	0.75	11.28	-0.009	0.000	-0.020	-0.013	-0.029	-0.031	0.007	0.002	0.011	0.013
13	0.82	12.30	-0.012	-0.001	-0.024	-0.016	-0.032	-0.035	0.007	0.001	0.013	0.015
14	0.87	13.11	-0.018	-0.006	-0.029	-0.021	-0.034	-0.039	0.007	-0.001	0.019	0.017
15	0.91	13.62	-0.024	-0.010	-0.034	-0.026	-0.035	-0.041	0.007	-0.002	0.024	0.018
16	0.93	13.99	-0.029	-0.017	-0.041	-0.032	-0.038	-0.045	0.007	-0.004	0.030	0.020
17	0.96	14.43	-0.035	-0.023	-0.047	-0.039	-0.041	-0.048	0.006	-0.006	0.036	0.022
18	0.95	14.28	-0.036	-0.023	-0.047	-0.039	-0.041	-0.048	0.006	-0.006	0.036	0.022
19	0.99	14.79	-0.042	-0.029	-0.053	-0.044	-0.043	-0.051	0.004	-0.008	0.042	0.025
20	0.99	14.87	-0.051	-0.039	-0.062	-0.053	-0.047	-0.056	0.002	-0.012	0.051	0.028
21	1.01	15.10	-0.073	-0.061	-0.083	-0.075	-0.058	-0.068	-0.008	-0.023	0.073	0.039
22	1.02	15.24	-0.083	-0.070	-0.092	-0.083	-0.064	-0.075	-0.013	-0.029	0.082	0.045
23	1.01	15.16	-0.093	-0.080	-0.103	-0.094	-0.071	-0.082	-0.021	-0.037	0.092	0.053
24	1.00	15.01	-0.106	-0.092	-0.116	-0.106	-0.084	-0.095	-0.034	-0.050	0.105	0.066
25	1.00	14.94	-0.114	-0.102	-0.124	-0.116	-0.093	-0.104	-0.043	-0.059	0.114	0.075
26	0.98	14.65	-0.133	-0.120	-0.143	-0.133	-0.109	-0.120	-0.061	-0.076	0.132	0.092
27	0.96	14.36	-0.157	-0.144	-0.165	-0.157	-0.132	-0.144	-0.083	-0.099	0.156	0.114
28	0.92	13.77	-0.204	-0.191	-0.213	-0.203	-0.177	-0.188	-0.128	-0.144	0.203	0.159
29	0.87	13.04	-0.258	-0.248	-0.268	-0.259	-0.232	-0.242	-0.183	-0.197	0.258	0.214
30	0.84	12.60	-0.316	-0.307	-0.325	-0.317	-0.288	-0.300	-0.242	-0.256	0.316	0.271
31	0.83	12.45	-0.364	-0.354	-0.373	-0.364	-0.338	-0.349	-0.290	-0.304	0.364	0.320
32	0.82	12.23	-0.397	-0.387	-0.404	-0.397	-0.370	-0.381	-0.323	-0.335	0.396	0.352
33	0.79	11.87	-0.451	-0.443	-0.460	-0.453	-0.425	-0.438	-0.380	-0.393	0.452	0.409
34	0.77	11.57	-0.505	-0.496	-0.511	-0.505	-0.477	-0.490	-0.432	-0.445	0.504	0.461
35	0.76	11.35	-0.552	-0.544	-0.558	-0.552	-0.523	-0.536	-0.479	-0.493	0.551	0.508
36	0.75	11.21	-0.591	-0.584	-0.596	-0.591	-0.562	-0.576	-0.518	-0.531	0.591	0.547

Table C-16

TENSION TESTS ON BOLTED CONNECTIONS

SUMMARY SHEET

Test No: 17

Date: March 14, 1995

Test Designation: 1/4x1x3/4

Recorder: Burak Karsu

GEOMETRIC AND MATERIAL PROPERTIES

BOLT

Type:A325

Diameter $d_b=0.75$

Length $L_b= 2.5$ in.

Shear Str. $F_v=72$ ksi

Edge Dist. $e=1.5$ in.

Fully Pretensioned--Yes

Bolt Hole Fabr.--Drilled

Bolt Hole Type--Standard

Threads in Shear Plane--X

PLATES

No	Designation	Length (in.)	Width (in.)	Thickness (in.)	Hole Dia. (in.)	Fy (ksi)	Fu (ksi)
Plate 1	PL-18	24.0	4.0	0.25	14/16	47.5	66.7
Plate 2	PL-5	24.0	4.0	1.0	14/16	44.0	70.0

TEST RESULTS

Failure Type: Bearing /Tear Out

Failure Load: 27040 lbs/plate

Max Deflection $\Delta_{max}=0.47$ in.

Failure Plate: PL-18

COMMENTS

* Yielding on PL-18 started at 22000 lbs and 0.025 in.

* At 25000 lbs splitting occurred.

* After 27000 lbs at 0.15 in. load decreased.

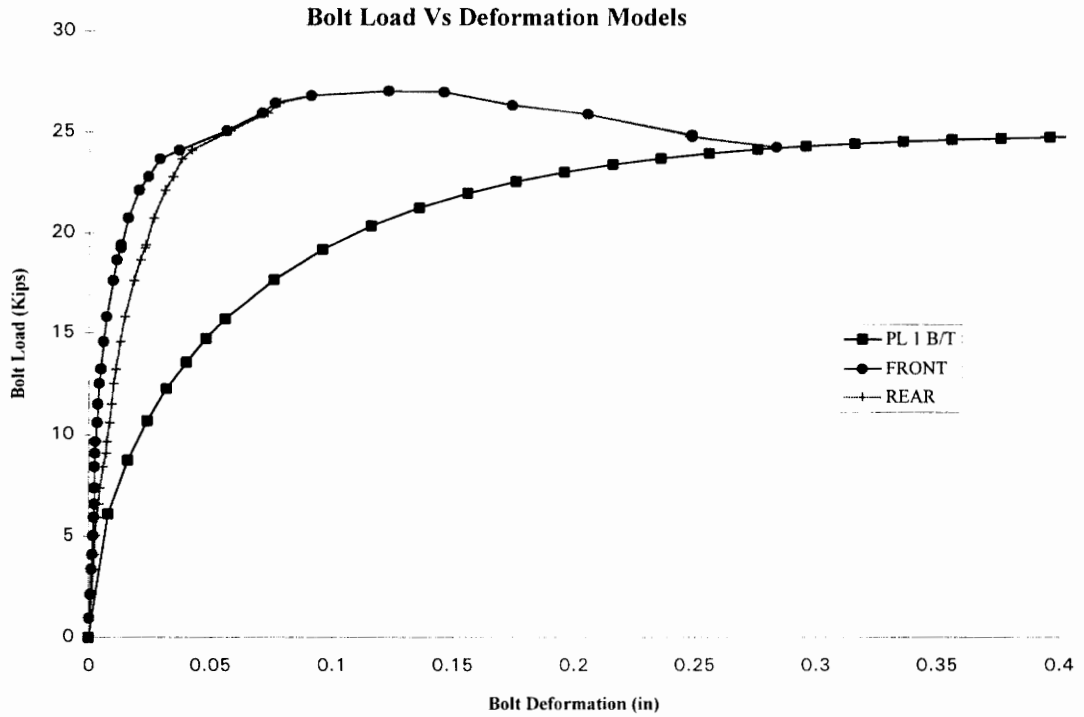

Figure C-17

Plate				Bolt	
	tp	Fu	B/T	Bolt Dia.	A325 0.75
Plate 1	0.25	66.7	25.01	Fv	72
Plate 2	1	70	105.00	Bolt Shear	30.8

Richard Coefficients

K= 0 Kp= 0 Ro= 0
 K1= 0 n= 0

Data Point	Volts	Load	F1	F2	F3	F4	R1	R2	R3	R4	AVG(F)	AVG(R)
1	0.06	0.95	0.000	0.000	-0.001	-0.001	-0.002	0.000	-0.001	0.001	0.000	0.000
2	0.14	2.12	-0.001	0.000	-0.001	-0.001	-0.003	-0.002	-0.001	0.001	0.001	0.001
3	0.22	3.37	-0.001	0.000	-0.002	-0.002	-0.004	-0.004	-0.001	0.001	0.001	0.002
4	0.27	4.10	-0.001	0.000	-0.002	-0.003	-0.005	-0.005	0.000	0.001	0.002	0.002
5	0.34	5.05	-0.001	0.000	-0.003	-0.004	-0.005	-0.006	0.000	0.001	0.002	0.003
6	0.40	5.93	-0.001	0.000	-0.004	-0.004	-0.007	-0.007	0.000	0.001	0.002	0.003
7	0.44	6.59	-0.001	0.000	-0.004	-0.004	-0.009	-0.009	0.000	0.001	0.002	0.004
8	0.49	7.40	-0.001	0.000	-0.004	-0.004	-0.010	-0.010	0.001	0.001	0.002	0.005
9	0.56	8.42	-0.001	0.000	-0.004	-0.004	-0.013	-0.013	0.001	0.001	0.002	0.006
10	0.61	9.08	-0.002	0.000	-0.004	-0.004	-0.015	-0.016	0.001	0.001	0.003	0.007
11	0.64	9.67	-0.002	0.000	-0.005	-0.004	-0.015	-0.017	0.002	0.001	0.003	0.007
12	0.71	10.62	-0.002	0.000	-0.006	-0.006	-0.016	-0.020	0.002	-0.001	0.004	0.009
13	0.77	11.50	-0.002	0.000	-0.007	-0.006	-0.017	-0.022	0.002	-0.001	0.004	0.009
14	0.83	12.52	-0.002	-0.001	-0.007	-0.007	-0.018	-0.025	0.004	-0.002	0.004	0.010
15	0.88	13.26	-0.002	-0.001	-0.009	-0.009	-0.018	-0.027	0.004	-0.003	0.005	0.011
16	0.97	14.58	-0.002	-0.001	-0.010	-0.011	-0.020	-0.031	0.005	-0.006	0.006	0.013
17	1.06	15.83	-0.002	-0.002	-0.011	-0.014	-0.020	-0.036	0.006	-0.008	0.007	0.015
18	1.18	17.65	-0.002	-0.005	-0.013	-0.019	-0.024	-0.043	0.006	-0.012	0.010	0.018
19	1.25	18.69	-0.003	-0.007	-0.014	-0.022	-0.026	-0.048	0.006	-0.015	0.011	0.021
20	1.29	19.42	-0.003	-0.009	-0.015	-0.026	-0.028	-0.051	0.004	-0.018	0.013	0.023
21	1.28	19.27	-0.003	-0.009	-0.015	-0.026	-0.027	-0.051	0.005	-0.018	0.013	0.023
22	1.38	20.74	-0.004	-0.012	-0.018	-0.031	-0.031	-0.057	0.004	-0.021	0.016	0.026
23	1.48	22.13	-0.006	-0.017	-0.021	-0.039	-0.035	-0.065	0.002	-0.026	0.020	0.031
24	1.52	22.79	-0.007	-0.022	-0.023	-0.045	-0.038	-0.070	0.001	-0.030	0.024	0.034
25	1.58	23.67	-0.010	-0.027	-0.028	-0.052	-0.041	-0.076	-0.001	-0.034	0.029	0.038
26	1.61	24.11	-0.015	-0.035	-0.034	-0.063	-0.045	-0.081	-0.004	-0.038	0.037	0.042
27	1.67	25.06	-0.031	-0.057	-0.052	-0.086	-0.060	-0.100	-0.017	-0.054	0.056	0.058
28	1.73	25.94	-0.043	-0.072	-0.065	-0.103	-0.076	-0.118	-0.030	-0.069	0.071	0.073
29	1.76	26.45	-0.048	-0.077	-0.071	-0.109	-0.081	-0.124	-0.034	-0.074	0.076	0.078
30	1.79	26.82	-0.062	-0.092	-0.085	-0.125	-0.094	-0.138	-0.047	-0.087	0.091	0.091
31	1.80	27.04	-0.092	-0.125	-0.117	-0.158	-0.125	-0.169	-0.076	-0.119	0.123	0.122
32	1.80	26.96	-0.114	-0.148	-0.140	-0.182	-0.149	-0.193	-0.100	-0.143	0.146	0.146
33	1.75	26.30	-0.142	-0.176	-0.168	-0.212	-0.178	-0.223	-0.128	-0.173	0.174	0.175
34	1.72	25.86	-0.172	-0.209	-0.199	-0.243	-0.208	-0.252	-0.158	-0.202	0.206	0.205
35	1.66	24.84	-0.215	-0.253	-0.242	-0.286	-0.250	-0.295	-0.202	-0.244	0.249	0.248
36	1.65	24.77	-0.215	-0.253	-0.242	-0.286	-0.250	-0.295	-0.202	-0.244	0.249	0.248
37	1.62	24.25	-0.250	-0.288	-0.276	-0.322	-0.285	-0.330	-0.239	-0.280	0.284	0.283
38	1.62	24.33	-0.322	-0.357	-0.347	-0.395	-0.357	-0.402	-0.312	-0.354	0.355	0.357
39	1.52	22.79	-0.436	-0.472	-0.462	-0.508	-0.460	-0.507	-0.413	-0.454	0.470	0.459

Table C-17

TENSION TESTS ON BOLTED CONNECTIONS

SUMMARY SHEET

Test No: 18

Date: March 15, 1995

Test Designation: 3/8x3/8x3/4

Recorder: Burak Karsu

GEOMETRIC AND MATERIAL PROPERTIES

BOLT

Type: A325

Diameter $d_b=0.75$

Length $L_b=2$ in.

Shear Str. $F_v=72$ ksi

Edge Dist. $e=1.5$ in.

Fully Pretensioned--Yes

Bolt Hole Fabr.--Drilled

Bolt Hole Type--Standard

Threads in Shear Plane--X

PLATES

<u>No</u>	<u>Designation</u>	<u>Length (in.)</u>	<u>Width (in.)</u>	<u>Thickness (in.)</u>	<u>Hole Dia. (in.)</u>	<u>Fy (ksi)</u>	<u>Fu (ksi)</u>
Plate 1	PL-21	24.0	4.0	0.375	14/16	43.4	63.7
Plate 2	PL-21	24.0	4.0	0.375	14/16	43.4	63.7

TEST RESULTS

Failure Type: Splitting

Failure Load: 35000 lbs/plate

Max Deflection $\Delta_{max}=1.2$ in.

Failure Plate: PL-21

COMMENTS

- * Yielding occurred on PL-21 at 24000 lbs and 0.05 in.
- * Bulging on PL-21 started at 0.1 in.
- * Tips of the plates curled back at 30500 lbs and 0.21 in.

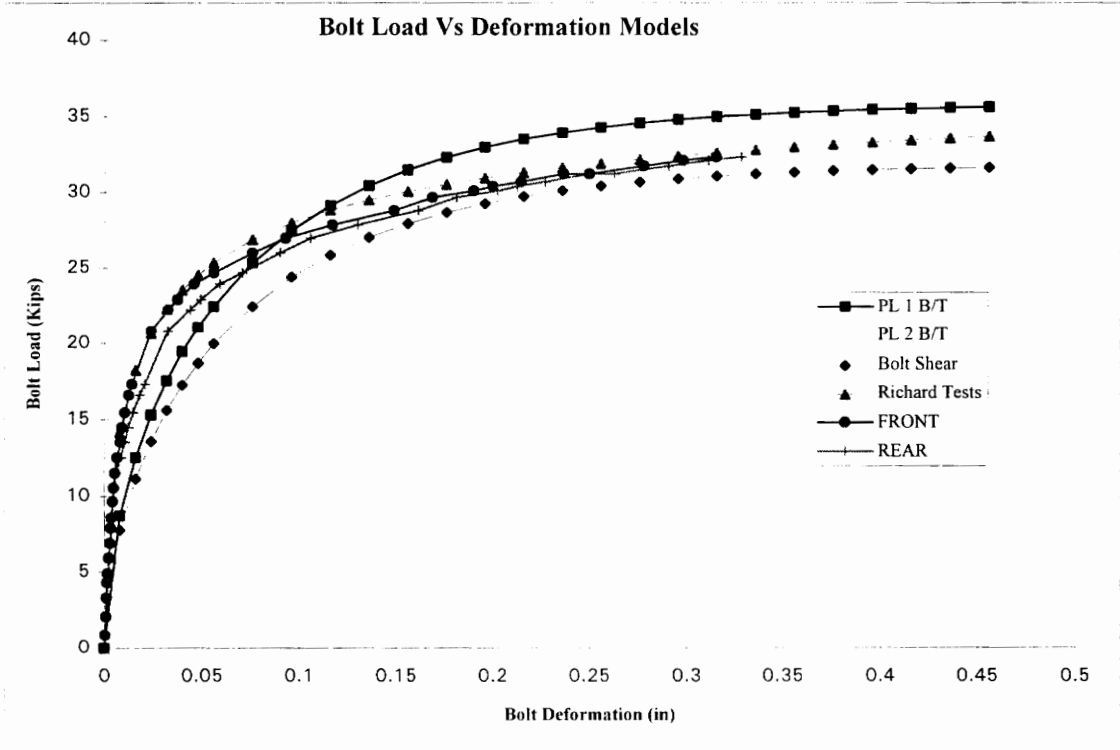

Figure C-18

Plate			Bolt		
	tp	Fu	B/T	Bolt Dia.	A325 0.75
Plate 1	0.375	63.7	35.83	Fv	72
Plate 2	0.375	63.7	35.83	Bolt Shear	30.8

Richard Coefficients

K= 10875 Kp= 0 Ro= 50
 K1= 19313 n= 0.5

Data Point	Volts	Load	F1	F2	F3	F4	R1	R2	R3	R4	AVG(F)	AVG(R)
1	0.06	0.87	-0.001	-0.001	-0.001	0.000	-0.001	0.000	-0.001	-0.001	0.000	0.001
2	0.14	2.05	-0.001	-0.001	-0.001	-0.001	-0.001	-0.001	-0.002	-0.001	0.001	0.001
3	0.22	3.30	-0.001	-0.001	-0.002	-0.001	-0.002	-0.002	-0.002	-0.001	0.001	0.002
4	0.29	4.32	-0.002	-0.002	-0.002	-0.001	-0.002	-0.002	-0.002	-0.001	0.002	0.002
5	0.33	4.91	-0.002	-0.002	-0.002	-0.001	-0.002	-0.002	-0.002	-0.001	0.002	0.002
6	0.40	5.93	-0.003	-0.002	-0.004	-0.001	-0.003	-0.002	-0.003	-0.001	0.002	0.002
7	0.46	6.88	-0.004	-0.002	-0.004	-0.001	-0.005	-0.002	-0.004	-0.001	0.003	0.003
8	0.53	7.91	-0.005	-0.002	-0.005	-0.001	-0.005	-0.003	-0.005	-0.001	0.003	0.004
9	0.57	8.57	-0.006	-0.002	-0.006	-0.001	-0.006	-0.003	-0.006	-0.001	0.004	0.004
10	0.64	9.67	-0.006	-0.003	-0.007	-0.001	-0.007	-0.004	-0.006	-0.001	0.004	0.004
11	0.70	10.55	-0.007	-0.003	-0.007	-0.001	-0.008	-0.004	-0.007	-0.002	0.005	0.005
12	0.77	11.50	-0.009	-0.003	-0.009	-0.001	-0.009	-0.004	-0.007	-0.002	0.006	0.006
13	0.83	12.52	-0.012	-0.003	-0.010	-0.001	-0.012	-0.007	-0.011	-0.004	0.007	0.008
14	0.90	13.55	-0.015	-0.004	-0.013	-0.002	-0.014	-0.009	-0.014	-0.006	0.008	0.011
15	0.97	14.50	-0.016	-0.004	-0.015	-0.002	-0.017	-0.010	-0.016	-0.007	0.009	0.012
16	1.03	15.45	-0.017	-0.005	-0.017	-0.003	-0.020	-0.012	-0.019	-0.009	0.011	0.015
17	1.11	16.63	-0.020	-0.006	-0.020	-0.004	-0.024	-0.015	-0.024	-0.010	0.013	0.018
18	1.16	17.36	-0.021	-0.007	-0.022	-0.006	-0.028	-0.017	-0.026	-0.012	0.014	0.021
19	1.39	20.80	-0.032	-0.016	-0.033	-0.015	-0.042	-0.028	-0.040	-0.021	0.024	0.033
20	1.48	22.27	-0.041	-0.024	-0.042	-0.024	-0.054	-0.039	-0.051	-0.031	0.033	0.044
21	1.53	22.93	-0.045	-0.029	-0.046	-0.029	-0.060	-0.044	-0.057	-0.037	0.037	0.049
22	1.53	22.93	-0.045	-0.030	-0.046	-0.029	-0.060	-0.043	-0.057	-0.037	0.038	0.049
23	1.60	23.96	-0.053	-0.039	-0.054	-0.038	-0.071	-0.053	-0.067	-0.046	0.046	0.059
24	1.65	24.69	-0.062	-0.050	-0.064	-0.049	-0.083	-0.065	-0.078	-0.058	0.056	0.071
25	1.73	26.01	-0.081	-0.070	-0.084	-0.069	-0.101	-0.085	-0.097	-0.077	0.076	0.090
26	1.80	26.96	-0.098	-0.087	-0.101	-0.086	-0.116	-0.101	-0.113	-0.093	0.093	0.106
27	1.86	27.84	-0.122	-0.111	-0.124	-0.111	-0.141	-0.125	-0.138	-0.118	0.117	0.130
28	1.92	28.79	-0.154	-0.144	-0.155	-0.143	-0.171	-0.155	-0.169	-0.149	0.149	0.161
29	1.98	29.67	-0.172	-0.164	-0.175	-0.163	-0.191	-0.175	-0.189	-0.170	0.169	0.181
30	2.01	30.11	-0.194	-0.186	-0.196	-0.185	-0.213	-0.196	-0.210	-0.191	0.190	0.202
31	2.03	30.40	-0.204	-0.196	-0.205	-0.195	-0.223	-0.206	-0.221	-0.200	0.200	0.213
32	2.05	30.70	-0.218	-0.211	-0.220	-0.210	-0.237	-0.221	-0.235	-0.215	0.215	0.227
33	2.08	31.21	-0.239	-0.234	-0.242	-0.232	-0.260	-0.244	-0.258	-0.238	0.237	0.250
34	2.08	31.21	-0.251	-0.248	-0.255	-0.246	-0.273	-0.256	-0.272	-0.251	0.250	0.263
35	2.11	31.72	-0.279	-0.277	-0.283	-0.275	-0.301	-0.284	-0.300	-0.279	0.278	0.291
36	2.14	32.09	-0.300	-0.297	-0.303	-0.295	-0.321	-0.304	-0.322	-0.300	0.299	0.312
37	2.15	32.31	-0.316	-0.315	-0.320	-0.313	-0.338	-0.321	-0.339	-0.317	0.316	0.329
38	2.18	32.68	-0.338	-0.338	-0.342	-0.335	-0.360	-0.344	-0.361	-0.340	0.338	0.351
39	2.20	32.97	-0.365	-0.366	-0.371	-0.364	-0.389	-0.373	-0.390	-0.369	0.366	0.380
40	2.24	33.55	-0.465	-0.469	-0.470	-0.467	-0.495	-0.479	-0.495	-0.469	0.468	0.484
41	2.27	33.99	-0.584	-0.590	-0.591	-0.588	-0.629	-0.613	-0.625	-0.599	0.588	0.616
42	2.29	34.29	-0.697	-0.704	-0.704	-0.702	-0.755	-0.740	-0.756	-0.725	0.702	0.744
43	2.32	34.80	-0.812	-0.821	-0.818	-0.815	-0.881	-0.864	-0.887	-0.855	0.816	0.871
44	2.32	34.80	-0.956	-0.966	-0.959	-0.960	-1.037	-1.018	-1.052	-1.019	0.960	1.031
45	2.33	35.02	-1.015	-1.025	-1.013	-1.015	-1.099	-1.082	-1.119	-1.087	1.017	1.097
46	2.09	31.36	-1.087	-1.098	-1.081	-1.081	-1.197	-1.183	-1.224	-1.195	1.087	1.200

Table C-18

TENSION TESTS ON BOLTED CONNECTIONS

SUMMARY SHEET

Test No: 19

Date: March 15, 1995

Test Designation: 3/8x1x3/4

Recorder: Burak Karsu

GEOMETRIC AND MATERIAL PROPERTIES

BOLT

Type: A325

Diameter $d_b=0.75$

Length $L_b=2.75$ in.

Shear Str. $F_v=72$ ksi

Edge Dist. $e=1.5$ in.

Fully Pretensioned--Yes

Bolt Hole Fabr.--Drilled

Bolt Hole Type--Standard

Threads in Shear Plane--X

PLATES

<u>No</u>	<u>Designation</u>	<u>Length (in.)</u>	<u>Width (in.)</u>	<u>Thickness (in.)</u>	<u>Hole Dia. (in.)</u>	<u>Fy (ksi)</u>	<u>Fu (ksi)</u>
Plate 1	PL-21	24.0	4.0	0.375	14/16	43.4	63.7
Plate 2	PL-5	24.0	4.0	1.0	14/16	44.0	70.0

TEST RESULTS

Failure Type: Bolt Shear

Failure Load: 38500 lbs/bolt

Max Deflection $\Delta_{max}=0.49$ in.

Failure Plate: N/A

COMMENTS

* Yielding on PL-21 observed at 25000 lbs.

* Bulging on PL-21 observed at 37000 lbs.

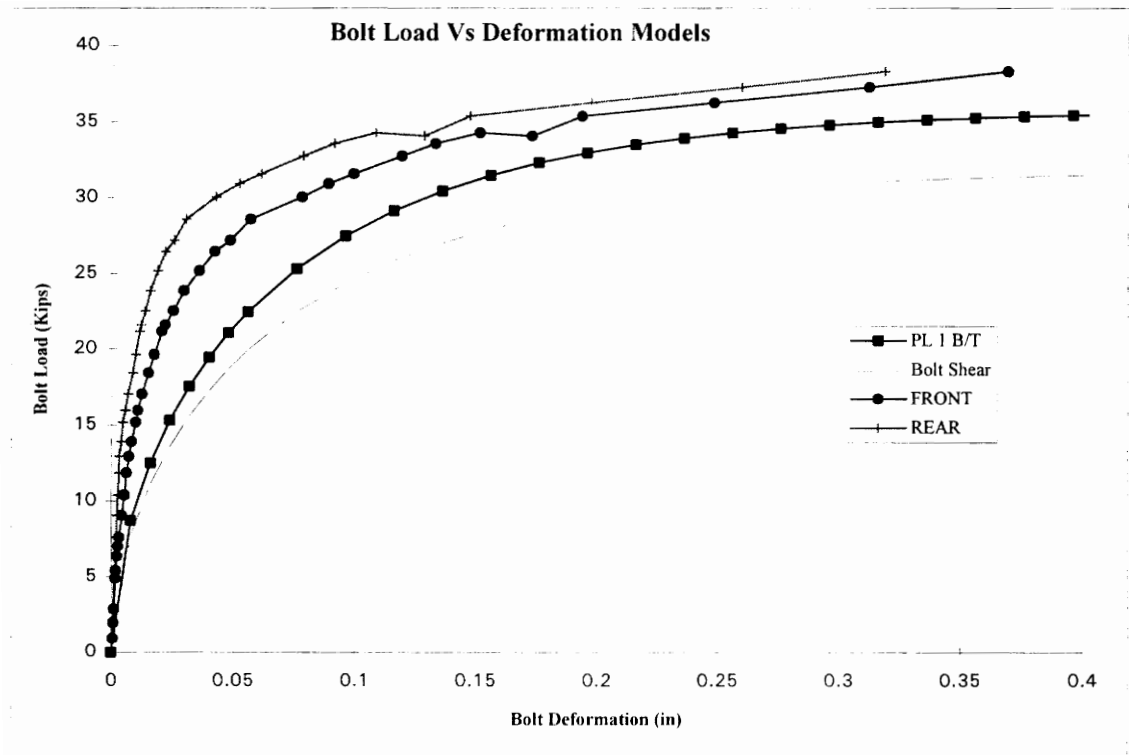

Figure C-19

Plate				Bolt		A325
	tp	Fu	B/T	Bolt Dia.		0.75
Plate 1	0.375	63.7	35.83	Fv		72
Plate 2	1	70	111.00	Bolt Shear		31.8

Richard Coefficients

K= 0 Kp= 0 Ro= 0
 K1= 0 n= 0

Data Point	Volts	Load	F1	F2	F3	F4	R1	R2	R3	R4	AVG(F)	AVG(R)
1	0.06	0.95	0.000	0.000	-0.001	-0.001	-0.001	0.000	-0.001	0.000	0.001	0.000
2	0.13	1.98	-0.001	0.000	-0.002	-0.001	-0.002	0.000	-0.001	0.000	0.001	0.001
3	0.19	2.86	0.000	0.000	-0.002	-0.002	-0.004	0.000	-0.001	0.001	0.001	0.001
4	0.33	4.91	0.000	0.000	-0.004	-0.003	-0.004	0.000	-0.001	0.001	0.002	0.001
5	0.36	5.42	0.000	0.001	-0.004	-0.004	-0.005	0.000	-0.001	0.001	0.002	0.001
6	0.42	6.37	-0.001	0.001	-0.006	-0.004	-0.006	0.000	-0.002	0.001	0.002	0.002
7	0.47	7.03	-0.001	0.001	-0.006	-0.006	-0.006	0.000	-0.002	0.001	0.003	0.002
8	0.51	7.62	-0.001	0.001	-0.007	-0.007	-0.007	0.000	-0.002	0.001	0.003	0.002
9	0.61	9.08	-0.001	0.001	-0.010	-0.009	-0.007	0.000	-0.004	0.001	0.004	0.002
10	0.69	10.40	-0.001	0.001	-0.012	-0.011	-0.007	0.000	-0.004	0.001	0.006	0.003
11	0.79	11.87	-0.001	0.001	-0.013	-0.013	-0.009	0.000	-0.005	0.001	0.006	0.003
12	0.86	12.96	-0.001	0.000	-0.014	-0.015	-0.010	0.000	-0.005	0.001	0.007	0.003
13	0.93	13.92	-0.001	-0.001	-0.015	-0.016	-0.012	0.000	-0.006	0.001	0.008	0.004
14	1.01	15.17	-0.002	-0.002	-0.017	-0.018	-0.014	0.000	-0.007	0.002	0.010	0.005
15	1.07	15.98	-0.002	-0.003	-0.018	-0.020	-0.016	0.000	-0.008	0.002	0.011	0.006
16	1.14	17.07	-0.004	-0.004	-0.020	-0.022	-0.020	0.000	-0.010	0.002	0.013	0.007
17	1.23	18.46	-0.006	-0.006	-0.023	-0.026	-0.024	0.000	-0.013	0.002	0.015	0.009
18	1.31	19.64	-0.007	-0.009	-0.026	-0.029	-0.028	0.000	-0.014	0.002	0.018	0.010
19	1.41	21.18	-0.008	-0.011	-0.029	-0.034	-0.032	0.000	-0.017	0.002	0.021	0.012
20	1.44	21.62	-0.009	-0.012	-0.031	-0.036	-0.033	0.000	-0.018	0.002	0.022	0.012
21	1.50	22.57	-0.010	-0.015	-0.035	-0.042	-0.036	0.000	-0.020	0.001	0.025	0.014
22	1.59	23.89	-0.013	-0.019	-0.039	-0.048	-0.040	0.000	-0.022	-0.001	0.030	0.016
23	1.68	25.20	-0.017	-0.024	-0.046	-0.056	-0.045	0.000	-0.026	-0.004	0.036	0.019
24	1.76	26.45	-0.022	-0.030	-0.053	-0.064	-0.051	0.000	-0.029	-0.008	0.042	0.022
25	1.81	27.18	-0.026	-0.036	-0.060	-0.072	-0.057	-0.001	-0.033	-0.012	0.049	0.026
26	1.90	28.57	-0.033	-0.044	-0.069	-0.082	-0.065	-0.001	-0.039	-0.017	0.057	0.030
27	2.00	30.04	-0.052	-0.064	-0.091	-0.105	-0.082	-0.004	-0.053	-0.032	0.078	0.043
28	2.06	30.92	-0.061	-0.076	-0.102	-0.117	-0.093	-0.012	-0.062	-0.042	0.089	0.052
29	2.11	31.58	-0.070	-0.086	-0.113	-0.129	-0.103	-0.021	-0.070	-0.050	0.099	0.061
30	2.18	32.75	-0.089	-0.106	-0.133	-0.150	-0.121	-0.041	-0.086	-0.067	0.119	0.079
31	2.24	33.55	-0.102	-0.119	-0.147	-0.165	-0.134	-0.054	-0.097	-0.080	0.133	0.091
32	2.29	34.29	-0.119	-0.138	-0.166	-0.184	-0.151	-0.073	-0.113	-0.096	0.152	0.108
33	2.27	34.07	-0.139	-0.158	-0.188	-0.207	-0.171	-0.095	-0.132	-0.116	0.173	0.128
34	2.36	35.39	-0.158	-0.179	-0.209	-0.229	-0.191	-0.116	-0.149	-0.134	0.194	0.147
35	2.42	36.26	-0.211	-0.234	-0.264	-0.286	-0.243	-0.169	-0.196	-0.183	0.248	0.198
36	2.49	37.29	-0.272	-0.298	-0.328	-0.351	-0.306	-0.234	-0.256	-0.244	0.312	0.260
37	2.55	38.32	-0.328	-0.354	-0.387	-0.409	-0.366	-0.294	-0.314	-0.301	0.369	0.319
38	2.55	38.32	-0.388	-0.415	-0.448	-0.473	-0.431	-0.361	-0.378	-0.366	0.431	0.384
39	2.57	38.54	-0.446	-0.474	-0.508	-0.533	-0.492	-0.423	-0.438	-0.425	0.490	0.444
40	0.44	6.59	-1.518	-0.843	-1.102	-1.523	-0.487	-0.450	-0.426	-0.426	1.247	0.447

Table C-19

TENSION TESTS ON BOLTED CONNECTIONS

SUMMARY SHEET

Test No: 20

Date: March 15, 1995

Test Designation: 1/2x1/2x3/4

Recorder: Burak Karsu

GEOMETRIC AND MATERIAL PROPERTIES

BOLT

Type:A325 Diameter $d_b=0.75$ Length $L_b= 2.25$ in.

Shear Str. $F_v=72$ ksi Edge Dist. $e=1.5$ in. Fully Pretensioned--Yes

Bolt Hole Fabr.--Drilled Bolt Hole Type--Standard

Threads in Shear Plane--X

PLATES

<u>No</u>	<u>Designation</u>	<u>Length</u> <u>(in.)</u>	<u>Width</u> <u>(in.)</u>	<u>Thickness</u> <u>(in.)</u>	<u>Hole Dia.</u> <u>(in.)</u>	<u>Fy</u> <u>(ksi)</u>	<u>Fu</u> <u>(ksi)</u>
Plate 1	PL-26	24.0	4.0	0.5	14/16	44.0	64.5
Plate 2	PL-26	24.0	4.0	0.5	14/16	44.0	64.5

TEST RESULTS

Failure Type: Bolt shear

Failure Load: 35600 lbs/plate

Max Deflection $\Delta_{max}=0.30$ in.

Failure Plate: N/A

COMMENTS

* Yielding on PL-26 started at 28000 lbs.

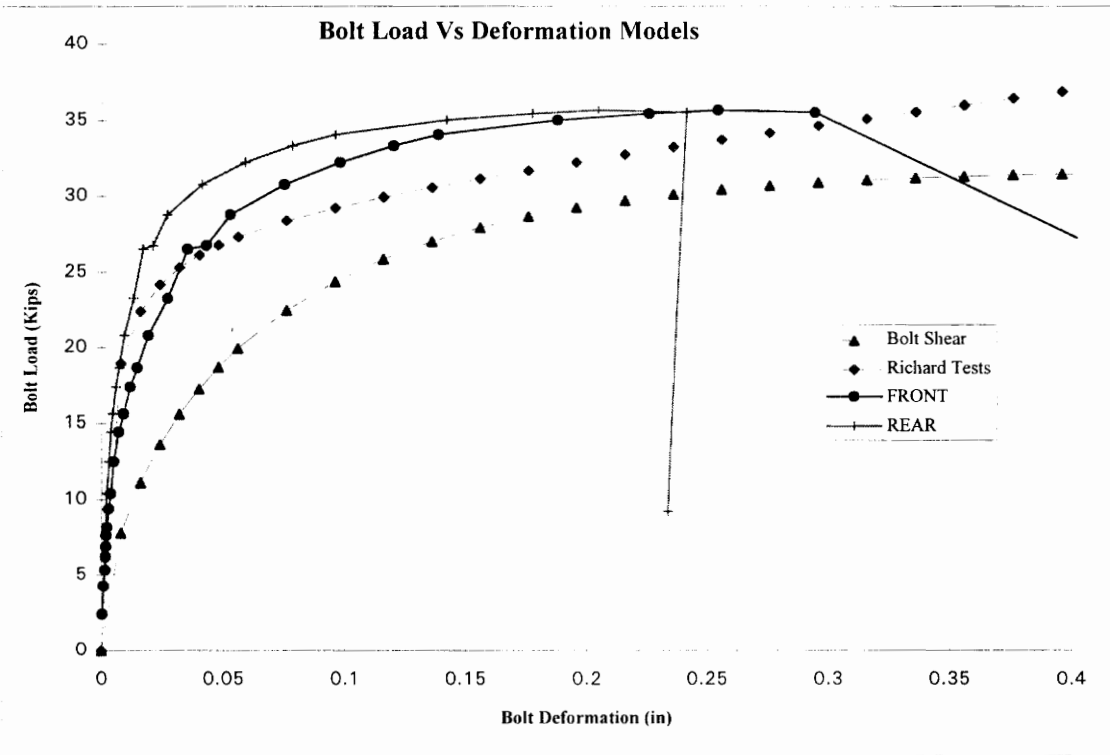

Figure C-20

Plate		Bolt		A325	
	tp	Fu	B/T	Bolt Dia.	0.75
Plate 1	0.5	64.5	48.38	Fv	72
Plate 2	0.5	64.5	48.38	Bolt Shear	31.8

Richard Coefficients

K= 14500 Kp= 20 Ro= 30
 K1= 14480 n= 0.7

Data Point	Volts	Load	F1	F2	F3	F4	R1	R2	R3	R4	AVG(F)	AVG(R)
1	0.16	2.42	-0.001	0.000	-0.001	0.000	-0.001	0.000	-0.001	-0.001	0.000	0.000
2	0.28	4.25	-0.002	-0.001	-0.001	0.000	-0.001	-0.001	-0.001	-0.001	0.001	0.001
3	0.36	5.35	-0.003	-0.001	-0.001	-0.001	-0.001	-0.001	-0.001	-0.001	0.002	0.001
4	0.42	6.23	-0.003	-0.001	-0.002	-0.001	-0.002	-0.001	-0.001	-0.002	0.002	0.002
5	0.46	6.88	-0.004	-0.001	-0.002	-0.001	-0.001	-0.001	-0.002	-0.002	0.002	0.001
6	0.51	7.62	-0.004	-0.001	-0.002	-0.001	-0.002	-0.001	-0.002	-0.002	0.002	0.002
7	0.54	8.13	-0.004	-0.001	-0.003	-0.001	-0.001	-0.001	-0.002	-0.002	0.002	0.002
8	0.63	9.38	-0.006	-0.001	-0.004	-0.001	-0.002	-0.001	-0.002	-0.002	0.003	0.002
9	0.69	10.40	-0.007	-0.001	-0.006	-0.001	-0.002	-0.001	-0.003	-0.003	0.004	0.002
10	0.83	12.45	-0.010	-0.001	-0.009	-0.001	-0.002	-0.002	-0.004	-0.004	0.005	0.003
11	0.96	14.44	-0.015	-0.001	-0.013	-0.001	-0.003	-0.003	-0.005	-0.004	0.007	0.004
12	1.04	15.61	-0.018	-0.001	-0.016	-0.001	-0.004	-0.004	-0.006	-0.006	0.009	0.005
13	1.16	17.43	-0.023	-0.002	-0.020	-0.002	-0.005	-0.006	-0.006	-0.007	0.012	0.006
14	1.25	18.68	-0.026	-0.004	-0.024	-0.004	-0.007	-0.007	-0.007	-0.008	0.015	0.007
15	1.39	20.81	-0.032	-0.009	-0.029	-0.007	-0.010	-0.009	-0.010	-0.010	0.019	0.009
16	1.55	23.30	-0.042	-0.016	-0.038	-0.013	-0.014	-0.012	-0.013	-0.013	0.027	0.013
17	1.77	26.52	-0.050	-0.024	-0.046	-0.021	-0.018	-0.015	-0.018	-0.017	0.035	0.017
18	1.78	26.74	-0.057	-0.031	-0.055	-0.028	-0.023	-0.019	-0.021	-0.020	0.043	0.021
19	1.92	28.79	-0.067	-0.042	-0.065	-0.037	-0.030	-0.025	-0.028	-0.025	0.053	0.027
20	2.05	30.77	-0.091	-0.064	-0.087	-0.059	-0.046	-0.039	-0.042	-0.038	0.075	0.041
21	2.15	32.24	-0.114	-0.087	-0.109	-0.081	-0.064	-0.057	-0.059	-0.055	0.098	0.059
22	2.22	33.33	-0.136	-0.110	-0.131	-0.104	-0.084	-0.076	-0.079	-0.074	0.120	0.078
23	2.27	34.07	-0.154	-0.128	-0.150	-0.123	-0.101	-0.093	-0.098	-0.092	0.139	0.096
24	2.34	35.03	-0.204	-0.177	-0.199	-0.172	-0.148	-0.139	-0.144	-0.138	0.188	0.142
25	2.36	35.46	-0.242	-0.215	-0.237	-0.210	-0.184	-0.176	-0.179	-0.173	0.226	0.178
26	2.38	35.68	-0.270	-0.245	-0.266	-0.237	-0.211	-0.203	-0.205	-0.200	0.255	0.205
27	2.37	35.53	-0.312	-0.284	-0.306	-0.276	-0.248	-0.240	-0.242	-0.236	0.295	0.241
28	0.62	9.23	-0.919	-0.633	-0.517	-0.479	-0.239	-0.240	-0.231	-0.225	0.637	0.234

Table C-20

TENSION TESTS ON BOLTED CONNECTIONS

SUMMARY SHEET

Test No: 21

Date: March 16, 1995

Test Designation: 1/2x5/8x3/4

Recorder: Burak Karsu

GEOMETRIC AND MATERIAL PROPERTIES

BOLT

Type:A325

Diameter $d_b=0.75$

Length $L_b= 2.5$

Shear Str. $F_v=72$ ksi

Edge Dist. $e=1.5$ in.

Fully Pretensioned--Yes

Bolt Hole Fabr.--Drilled

Bolt Hole Type--Standard

Threads in Shear Plane--X

PLATES

No	Designation	Length (in.)	Width (in.)	Thickness (in.)	Hole Dia. (in.)	Fy (ksi)	Fu (ksi)
Plate 1	PL-26	24.0	4.0	0.5	14/16	44.0	64.5
Plate 2	PL-27	24.0	4.0	0.625	14/16	44.8	68.2

TEST RESULTS

Failure Type: Bolt shear

Failure Load: 40000 lbs/bolt

Max Deflection $\Delta_{max}=0.27$ in.

Failure Plate: N/A

COMMENTS

* Yielding on PL-26 started at 29000 lbs and .025 in.

* PL-27 yielded at 34000 lbs.

* Bulging observed on PL-26 at 40000 lbs.

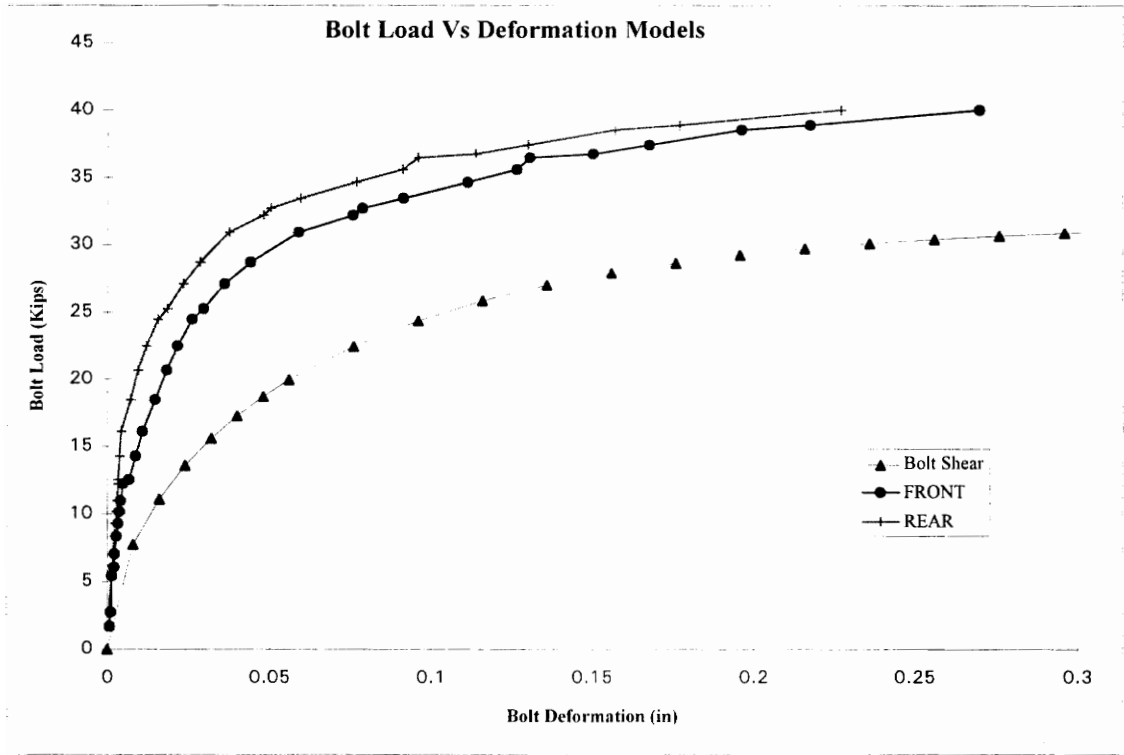

Figure C-21

Plate	tp	Fu	B/T	Bolt	A325
Plate 1	0.5	64.5	48.38	Bolt Dia.	0.75
Plate 2	0.625	68.2	63.94	Fv	72
				Bolt Shear	31.8

Richard Coefficients

K= 0 Kp= 0 Ro= 0
 K1= 0 n= 0

Data point	Volts	Load	F1	F2	F3	F4	R1	R2	R3	R4	AVG(F)	AVG(R)
1	0.07	1.70	-0.001	-0.001	-0.001	-0.001	-0.001	-0.001	0.000	-0.001	0.001	0.000
2	0.14	2.73	-0.001	-0.001	-0.001	-0.001	-0.001	-0.001	0.000	-0.001	0.001	0.001
3	0.32	5.44	-0.001	-0.001	-0.002	-0.002	-0.002	-0.001	-0.001	-0.001	0.002	0.001
4	0.36	6.09	-0.002	-0.002	-0.002	-0.002	-0.002	-0.002	-0.001	-0.002	0.002	0.002
5	0.42	7.05	-0.002	-0.002	-0.002	-0.003	-0.002	-0.002	-0.001	-0.002	0.002	0.002
6	0.51	8.37	-0.002	-0.003	-0.002	-0.004	-0.003	-0.003	-0.001	-0.002	0.003	0.002
7	0.58	9.32	-0.002	-0.004	-0.002	-0.006	-0.004	-0.003	-0.001	-0.002	0.003	0.002
8	0.63	10.20	-0.002	-0.004	-0.003	-0.006	-0.004	-0.004	-0.002	-0.002	0.004	0.003
9	0.69	11.00	-0.002	-0.005	-0.002	-0.007	-0.005	-0.004	-0.002	-0.002	0.004	0.003
10	0.77	12.25	-0.002	-0.006	-0.003	-0.009	-0.005	-0.004	-0.002	-0.002	0.005	0.003
11	0.79	12.54	-0.002	-0.009	-0.004	-0.012	-0.004	-0.004	-0.002	-0.003	0.007	0.003
12	0.91	14.30	-0.002	-0.011	-0.006	-0.015	-0.005	-0.004	-0.002	-0.004	0.009	0.004
13	1.03	16.14	-0.003	-0.015	-0.006	-0.019	-0.005	-0.006	-0.003	-0.004	0.011	0.004
14	1.19	18.48	-0.005	-0.021	-0.008	-0.025	-0.010	-0.007	-0.007	-0.006	0.015	0.007
15	1.33	20.68	-0.007	-0.026	-0.010	-0.031	-0.013	-0.009	-0.009	-0.007	0.018	0.009
16	1.46	22.51	-0.008	-0.031	-0.012	-0.036	-0.016	-0.011	-0.012	-0.009	0.022	0.012
17	1.59	24.49	-0.011	-0.037	-0.015	-0.042	-0.021	-0.014	-0.016	-0.011	0.026	0.016
18	1.64	25.29	-0.013	-0.042	-0.017	-0.047	-0.024	-0.017	-0.020	-0.013	0.030	0.018
19	1.76	27.12	-0.017	-0.050	-0.021	-0.056	-0.031	-0.021	-0.024	-0.017	0.036	0.023
20	1.87	28.74	-0.023	-0.059	-0.028	-0.067	-0.037	-0.027	-0.029	-0.021	0.044	0.029
21	2.02	30.93	-0.035	-0.076	-0.041	-0.084	-0.047	-0.035	-0.039	-0.029	0.059	0.037
22	2.11	32.25	-0.050	-0.094	-0.057	-0.103	-0.059	-0.046	-0.048	-0.039	0.076	0.048
23	2.14	32.76	-0.053	-0.097	-0.059	-0.106	-0.060	-0.049	-0.051	-0.041	0.079	0.050
24	2.19	33.50	-0.064	-0.110	-0.072	-0.120	-0.071	-0.058	-0.059	-0.049	0.091	0.059
25	2.27	34.67	-0.083	-0.130	-0.091	-0.141	-0.090	-0.075	-0.076	-0.066	0.111	0.077
26	2.33	35.62	-0.097	-0.146	-0.105	-0.158	-0.104	-0.090	-0.090	-0.080	0.127	0.091
27	2.39	36.50	-0.102	-0.150	-0.109	-0.162	-0.110	-0.095	-0.095	-0.084	0.131	0.096
28	2.41	36.79	-0.120	-0.171	-0.128	-0.182	-0.128	-0.113	-0.113	-0.101	0.150	0.114
29	2.45	37.45	-0.137	-0.188	-0.145	-0.201	-0.145	-0.130	-0.129	-0.116	0.168	0.130
30	2.53	38.56	-0.165	-0.218	-0.172	-0.231	-0.173	-0.157	-0.156	-0.142	0.196	0.157
31	2.55	38.93	-0.185	-0.240	-0.193	-0.253	-0.194	-0.177	-0.175	-0.161	0.218	0.177
32	2.62	40.02	-0.236	-0.294	-0.244	-0.306	-0.246	-0.228	-0.225	-0.210	0.270	0.227

Table C-21

TENSION TESTS ON BOLTED CONNECTIONS

SUMMARY SHEET

Test No: 22

Date: March 15, 1995

Test Designation: 1/2x1x3/4

Recorder: Burak Karsu

GEOMETRIC AND MATERIAL PROPERTIES

BOLT

Type: A325

Diameter $d_b=0.75$

Length $L_b=2.75$ in.

Shear Str. $F_v=72$ ksi

Edge Dist. $e=1.5$ in.

Fully Pretensioned--Yes

Bolt Hole Fabr.--Drilled

Bolt Hole Type--Standard

Threads in Shear Plane--X

PLATES

No	Designation	Length (in.)	Width (in.)	Thickness (in.)	Hole Dia. (in.)	Fy (ksi)	Fu (ksi)
Plate 1	PL-26	24.0	4.0	0.5	14/16	44.0	64.5
Plate 2	PL-6	24.0	4.0	1.0	14/16	43.0	67.0

TEST RESULTS

Failure Type: Bolt shear

Failure Load: 37400 lbs/bolt

Max Deflection $\Delta_{max}=0.22$ in.

Failure Plate: N/A

COMMENTS

* Yielding started on PL-26 at 25000 lbs.

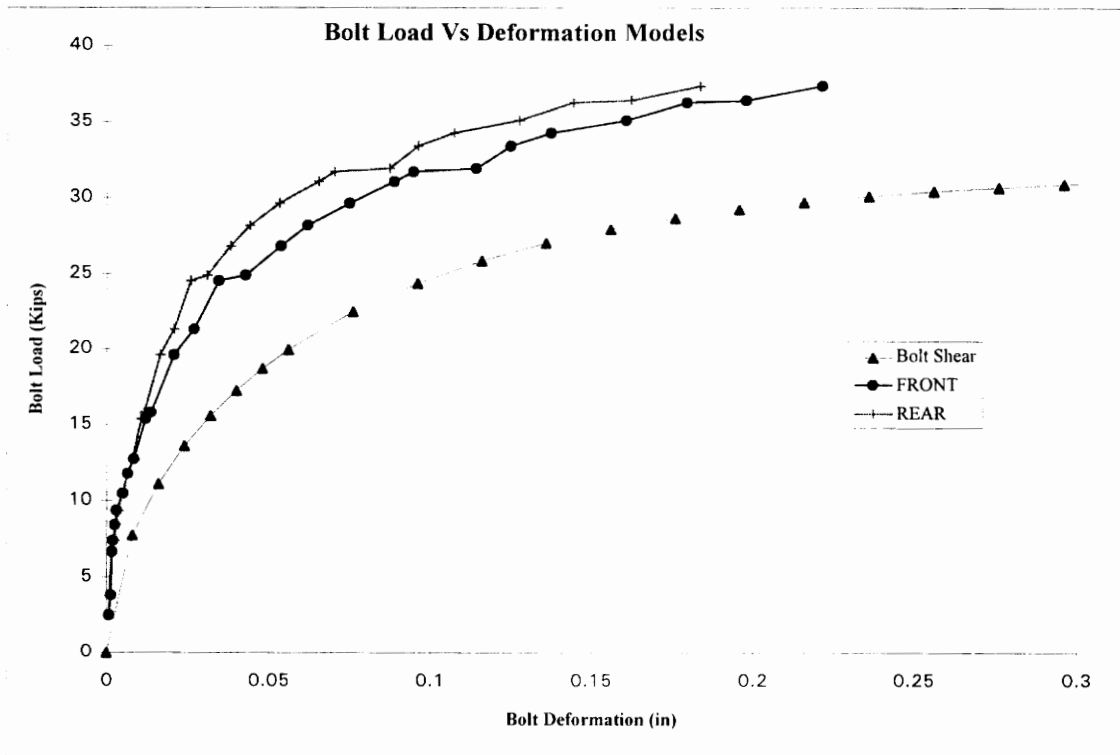

Figure C-22

Plate			Bolt		
	tp	Fu	B/T	Bolt Dia.	A325 0.75
Plate 1	0.5	64.5	48.38	Fv	72
Plate 2	1	67	100.50	Bolt Shear	31.8

Richard Coefficients

K= 0 Kp= 0 Ro= 0
 K1= 0 n= 0

Data Point	Volts	Load	F1	F2	F3	F4	R1	R2	R3	R4	AVG(F)	AVG(R)
1	0.17	2.49	-0.001	0.000	-0.001	-0.001	-0.002	-0.001	-0.001	0.000	0.001	0.001
2	0.25	3.81	-0.001	-0.001	-0.002	-0.002	-0.002	-0.001	-0.001	0.000	0.001	0.001
3	0.44	6.67	-0.001	0.000	-0.004	-0.002	-0.004	-0.002	-0.001	0.000	0.002	0.002
4	0.49	7.40	-0.001	0.000	-0.005	-0.002	-0.004	-0.004	-0.001	-0.001	0.002	0.002
5	0.56	8.42	-0.003	0.000	-0.006	-0.002	-0.005	-0.006	0.000	-0.001	0.003	0.003
6	0.63	9.38	-0.005	0.001	-0.008	-0.001	-0.005	-0.007	0.000	-0.002	0.003	0.004
7	0.70	10.47	-0.010	0.002	-0.013	0.001	-0.004	-0.011	0.002	-0.006	0.005	0.005
8	0.79	11.79	-0.013	0.003	-0.018	0.002	-0.004	-0.015	0.002	-0.009	0.007	0.007
9	0.85	12.74	-0.018	0.005	-0.024	0.004	-0.003	-0.019	0.003	-0.013	0.008	0.008
10	1.03	15.38	-0.028	0.009	-0.034	0.006	-0.002	-0.026	0.005	-0.020	0.012	0.011
11	1.05	15.82	-0.032	0.010	-0.040	0.007	-0.002	-0.028	0.006	-0.022	0.014	0.012
12	1.31	19.63	-0.046	0.013	-0.057	0.007	-0.002	-0.039	0.007	-0.032	0.021	0.017
13	1.42	21.32	-0.059	0.015	-0.070	0.007	-0.002	-0.048	0.007	-0.040	0.027	0.021
14	1.64	24.55	-0.070	0.012	-0.084	0.003	-0.005	-0.057	0.006	-0.047	0.035	0.026
15	1.66	24.91	-0.081	0.009	-0.096	-0.002	-0.008	-0.065	0.005	-0.055	0.043	0.031
16	1.79	26.82	-0.094	0.002	-0.111	-0.012	-0.013	-0.076	0.002	-0.065	0.054	0.038
17	1.88	28.21	-0.103	-0.004	-0.122	-0.019	-0.018	-0.085	-0.002	-0.072	0.062	0.044
18	1.98	29.67	-0.117	-0.013	-0.138	-0.031	-0.026	-0.097	-0.008	-0.082	0.075	0.053
19	2.07	31.06	-0.131	-0.024	-0.155	-0.044	-0.036	-0.113	-0.018	-0.095	0.089	0.065
20	2.11	31.72	-0.138	-0.029	-0.162	-0.049	-0.041	-0.118	-0.021	-0.100	0.095	0.070
21	2.13	31.94	-0.158	-0.047	-0.184	-0.068	-0.057	-0.138	-0.035	-0.118	0.114	0.087
22	2.23	33.41	-0.169	-0.056	-0.196	-0.079	-0.066	-0.148	-0.043	-0.127	0.125	0.096
23	2.29	34.29	-0.181	-0.067	-0.210	-0.091	-0.078	-0.160	-0.052	-0.139	0.137	0.107
24	2.34	35.09	-0.205	-0.089	-0.235	-0.114	-0.098	-0.183	-0.070	-0.160	0.161	0.128
25	2.42	36.27	-0.224	-0.107	-0.254	-0.132	-0.115	-0.201	-0.085	-0.177	0.180	0.144
26	2.43	36.41	-0.243	-0.125	-0.274	-0.149	-0.133	-0.219	-0.102	-0.195	0.198	0.162
27	2.49	37.36	-0.267	-0.148	-0.299	-0.172	-0.155	-0.242	-0.122	-0.216	0.222	0.184
28	0.25	3.74	-1.654	-0.715	-0.668	-1.952	-0.193	-0.249	-0.130	-0.219	1.247	0.198

Table C-22

TENSION TESTS ON BOLTED CONNECTIONS

SUMMARY SHEET

Test No: 23

Date: March 15, 1995

Test Designation: 5/8x5/8x3/4

Recorder: Burak Karsu

GEOMETRIC AND MATERIAL PROPERTIES

BOLT

Type: A325 Diameter $d_b=0.75$ Length $L_b=2.5$ in.

Shear Str. $F_v=72$ ksi Edge Dist. $e=1.5$ in. Fully Pretensioned--Yes

Bolt Hole Fabr.--Drilled Bolt Hole Type--Standard

Threads in Shear Plane--X

PLATES

No	Designation	Length (in.)	Width (in.)	Thickness (in.)	Hole Dia. (in.)	Fy (ksi)	Fu (ksi)
Plate 1	PL-13	24.0	4.0	0.625	14/16	47.0	70.0
Plate 2	PL-13	24.0	4.0	0.625	14/16	47.0	70.0

TEST RESULTS

Failure Type: Bolt shear

Failure Load: 35400 lbs/bolt

Max Deflection $\Delta_{max}=0.25$ in.

Failure Plate: N/A

COMMENTS

* PL-13 yielded at 27000 lbs. at 0.07 in.

* Bolts declined at 32000 lbs.

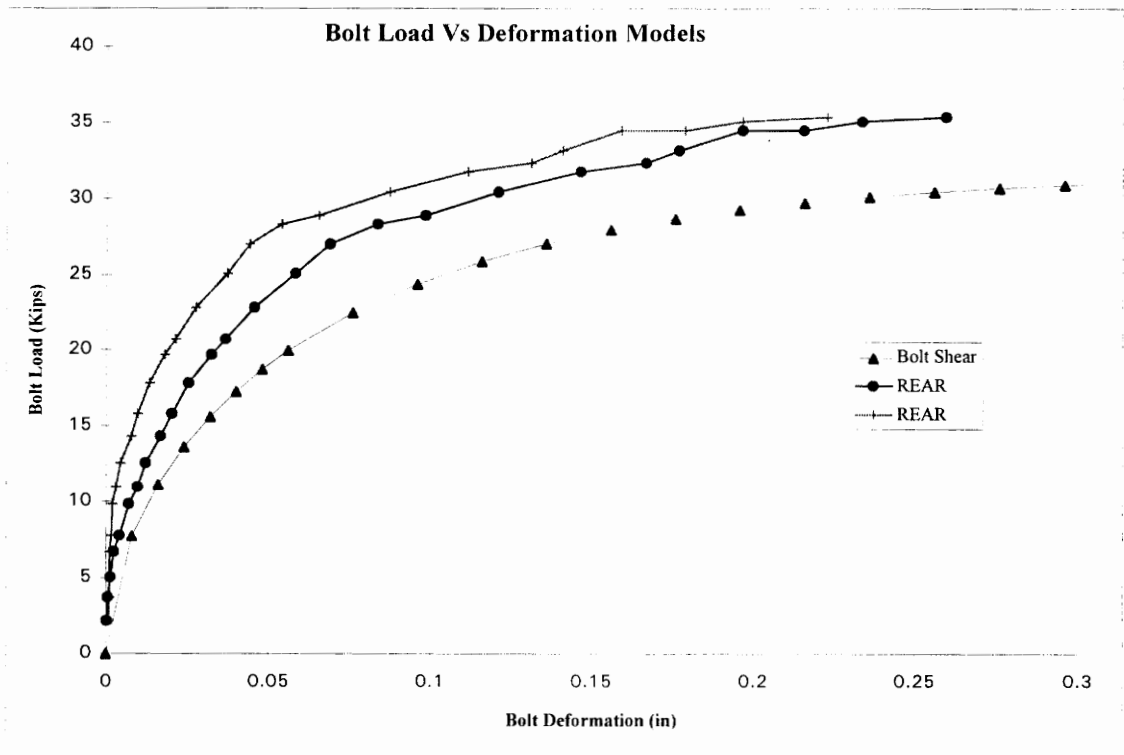

Figure C-23

Plate				Bolt		A325
	tp	Fu	B/T	Bolt Dia.		0.75
Plate 1	0.625	70	65.63	Fv		72
Plate 2	0.625	70	65.63	Bolt Shear		31.8

Richard Coefficients

K= 0 Kp= 0 Ro= 0
 K1= 0 n= 0

Data Point	Volts	Load	F1	F2	F3	F4	R1	R2	R3	R4	AVG(F)	AVG(R)
1	0.10	2.16	0.000	-0.001	0.000	-0.001	-0.002	-0.001	-0.001	0.000	0.000	0.001
2	0.20	3.70	0.000	-0.001	-0.001	-0.001	-0.002	-0.001	-0.001	0.000	0.001	0.001
3	0.29	5.02	0.001	-0.002	-0.001	-0.002	-0.002	-0.001	-0.001	0.000	0.001	0.001
4	0.40	6.71	0.002	-0.006	-0.001	-0.006	-0.002	-0.001	-0.001	0.000	0.002	0.001
5	0.47	7.80	0.003	-0.010	0.001	-0.010	-0.002	-0.002	-0.001	-0.001	0.004	0.002
6	0.61	9.86	0.005	-0.018	0.002	-0.017	-0.002	-0.003	-0.001	-0.001	0.007	0.002
7	0.68	10.95	0.006	-0.024	0.002	-0.024	-0.002	-0.005	-0.001	-0.004	0.010	0.003
8	0.79	12.57	0.007	-0.029	0.003	-0.030	-0.002	-0.009	-0.001	-0.007	0.012	0.004
9	0.91	14.32	0.007	-0.039	0.002	-0.039	-0.002	-0.015	-0.001	-0.013	0.017	0.008
10	1.01	15.80	0.007	-0.045	0.001	-0.045	-0.003	-0.018	-0.001	-0.017	0.020	0.010
11	1.14	17.85	0.005	-0.053	-0.001	-0.053	-0.005	-0.024	-0.002	-0.021	0.025	0.013
12	1.27	19.68	0.002	-0.063	-0.005	-0.064	-0.008	-0.031	-0.004	-0.029	0.032	0.018
13	1.33	20.70	-0.001	-0.069	-0.008	-0.070	-0.010	-0.035	-0.006	-0.034	0.037	0.021
14	1.48	22.83	-0.007	-0.080	-0.015	-0.081	-0.015	-0.044	-0.010	-0.042	0.046	0.028
15	1.63	25.10	-0.016	-0.095	-0.026	-0.096	-0.023	-0.057	-0.017	-0.053	0.058	0.037
16	1.75	27.00	-0.025	-0.108	-0.035	-0.108	-0.029	-0.065	-0.021	-0.062	0.069	0.044
17	1.84	28.32	-0.039	-0.123	-0.050	-0.123	-0.038	-0.077	-0.028	-0.073	0.084	0.054
18	1.88	28.91	-0.053	-0.138	-0.064	-0.138	-0.048	-0.090	-0.039	-0.085	0.098	0.065
19	1.98	30.45	-0.076	-0.162	-0.086	-0.161	-0.070	-0.112	-0.060	-0.108	0.121	0.087
20	2.07	31.76	-0.102	-0.187	-0.111	-0.186	-0.093	-0.137	-0.083	-0.134	0.147	0.111
21	2.11	32.35	-0.122	-0.207	-0.131	-0.207	-0.113	-0.157	-0.101	-0.153	0.167	0.131
22	2.16	33.16	-0.132	-0.218	-0.141	-0.217	-0.123	-0.167	-0.111	-0.163	0.177	0.141
23	2.25	34.47	-0.151	-0.238	-0.161	-0.237	-0.140	-0.186	-0.130	-0.181	0.197	0.159
24	2.25	34.47	-0.170	-0.258	-0.179	-0.256	-0.160	-0.206	-0.149	-0.200	0.216	0.179
25	2.29	35.06	-0.188	-0.275	-0.198	-0.275	-0.178	-0.224	-0.167	-0.218	0.234	0.197
26	2.31	35.35	-0.213	-0.300	-0.223	-0.301	-0.204	-0.251	-0.193	-0.244	0.259	0.223

Table C-23

TENSION TESTS ON BOLTED CONNECTIONS

SUMMARY SHEET

Test No: 25

Date: March 16, 1995

Test Designation: 1x1x3/4

Recorder: Burak Karsu

GEOMETRIC AND MATERIAL PROPERTIES

BOLT

Type:A325

Diameter $d_b=0.75$

Length $L_b= 3.25$ in.

Shear Str. $F_v=72$ ksi

Edge Dist. $e=1.5$ in.

Fully Pretensioned--Yes

Bolt Hole Fabr.--Drilled

Bolt Hole Type--Standard

Threads in Shear Plane--X

PLATES

No	Designation	Length (in.)	Width (in.)	Thickness (in.)	Hole Dia. (in.)	Fy (ksi)	Fu (ksi)
Plate 1	PL-6	24.0	4.0	1.0	14/16	43	67
Plate 2	PL-6	24.0	4.0	1.0	14/16	43	67

TEST RESULTS

Failure Type: Bolt Shear

Failure Load: 38000 lbs/bolt

Max Deflection $\Delta_{max}= 0.15$ in.

Failure Plate:

COMMENTS

* No visible change on the specimens.

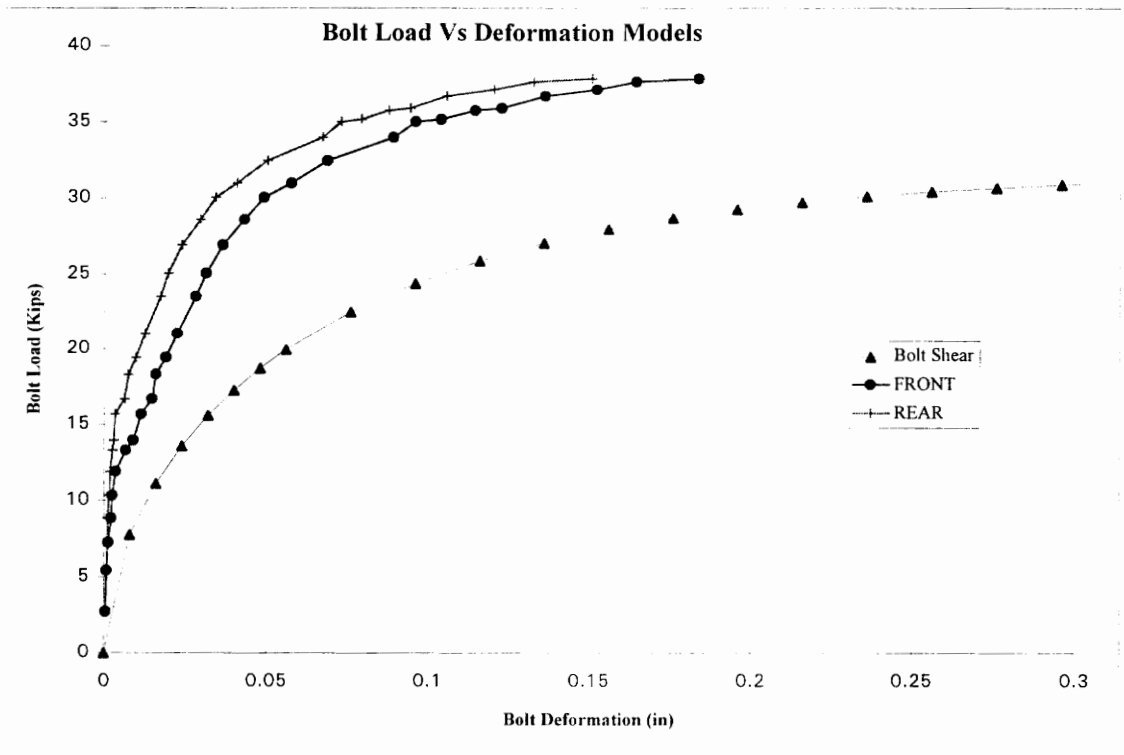

Figure C-25

Plate			Bolt		A325
	tp	Fu	B/T	Bolt Dia.	0.75
Plate 1	1	67	62.81	Fv	72
Plate 2	1	67	100.50	Bolt Shear	31.8

Richard Coefficients

K= 0 Kp= 0 Ro= 0
 K1= 0 n= 0

Data Point	Volts	Load	F1	F2	F3	F4	R1	R2	R3	R4	AVG(F)	AVG(R)
1	0.18	2.71	0.000	0.000	-0.001	-0.002	-0.001	-0.001	-0.001	0.000	0.001	0.000
2	0.36	5.42	0.000	0.000	-0.001	-0.002	-0.001	-0.001	-0.001	-0.001	0.001	0.001
3	0.48	7.25	0.000	-0.001	-0.002	-0.003	-0.001	-0.001	-0.001	-0.001	0.001	0.001
4	0.59	8.86	0.000	-0.001	-0.002	-0.006	-0.001	-0.001	-0.001	-0.001	0.002	0.001
5	0.69	10.33	0.000	-0.002	-0.002	-0.006	-0.002	-0.002	-0.002	-0.001	0.003	0.002
6	0.80	11.94	0.000	-0.004	-0.002	-0.009	-0.002	-0.002	-0.002	-0.001	0.004	0.002
7	0.89	13.33	0.001	-0.010	-0.002	-0.015	-0.002	-0.003	-0.002	-0.002	0.007	0.003
8	0.93	13.99	0.001	-0.015	-0.002	-0.020	-0.003	-0.003	-0.003	-0.003	0.009	0.003
9	1.05	15.68	0.001	-0.020	-0.002	-0.025	-0.004	-0.004	-0.003	-0.004	0.011	0.004
10	1.11	16.71	0.002	-0.027	-0.002	-0.031	-0.006	-0.007	-0.006	-0.006	0.015	0.006
11	1.22	18.32	0.002	-0.029	-0.002	-0.034	-0.007	-0.008	-0.007	-0.007	0.016	0.007
12	1.30	19.44	0.002	-0.035	-0.002	-0.040	-0.010	-0.010	-0.010	-0.009	0.019	0.010
13	1.40	21.03	0.002	-0.041	-0.004	-0.047	-0.014	-0.012	-0.013	-0.011	0.022	0.013
14	1.57	23.52	0.001	-0.050	-0.006	-0.057	-0.020	-0.015	-0.019	-0.015	0.028	0.017
15	1.67	25.06	0.000	-0.054	-0.008	-0.063	-0.024	-0.017	-0.021	-0.016	0.031	0.020
16	1.79	26.89	-0.003	-0.061	-0.010	-0.072	-0.029	-0.021	-0.026	-0.019	0.036	0.024
17	1.90	28.57	-0.006	-0.070	-0.015	-0.082	-0.035	-0.027	-0.032	-0.024	0.043	0.030
18	2.00	30.04	-0.010	-0.076	-0.020	-0.090	-0.041	-0.031	-0.037	-0.028	0.049	0.034
19	2.07	30.99	-0.015	-0.086	-0.027	-0.102	-0.048	-0.038	-0.043	-0.033	0.057	0.041
20	2.16	32.46	-0.024	-0.099	-0.035	-0.116	-0.059	-0.047	-0.053	-0.042	0.069	0.050
21	2.27	33.99	-0.040	-0.121	-0.054	-0.141	-0.076	-0.065	-0.070	-0.058	0.089	0.067
22	2.33	35.02	-0.046	-0.129	-0.061	-0.149	-0.082	-0.071	-0.075	-0.063	0.096	0.073
23	2.34	35.17	-0.052	-0.137	-0.068	-0.158	-0.089	-0.078	-0.081	-0.069	0.104	0.079
24	2.38	35.75	-0.062	-0.148	-0.078	-0.170	-0.098	-0.087	-0.089	-0.077	0.115	0.088
25	2.39	35.90	-0.069	-0.157	-0.086	-0.179	-0.105	-0.093	-0.096	-0.083	0.123	0.094
26	2.45	36.70	-0.081	-0.171	-0.099	-0.194	-0.117	-0.105	-0.107	-0.094	0.136	0.106
27	2.48	37.15	-0.096	-0.188	-0.115	-0.210	-0.132	-0.119	-0.122	-0.108	0.152	0.120
28	2.51	37.66	-0.107	-0.200	-0.127	-0.224	-0.144	-0.132	-0.134	-0.121	0.165	0.133
29	2.53	37.88	-0.125	-0.220	-0.146	-0.244	-0.163	-0.149	-0.152	-0.139	0.184	0.151

Table C-25

TENSION TESTS ON BOLTED CONNECTIONS

SUMMARY SHEET

Test No: 26

Date: March 17, 1995

Test Designation: 1/8x1/8x7/8

Recorder: Burak Karsu

GEOMETRIC AND MATERIAL PROPERTIES

BOLT

Type:A325

Diameter $d_b=0.875$

Length $L_b= 2.0$ in.

Shear Str. $F_v=72$ ksi

Edge Dist. $e=1.5$ in.

Fully Pretensioned--Yes

Bolt Hole Fabr.--Drilled

Bolt Hole Type--Standard

Threads in Shear Plane--X

PLATES

No	Designation	Length (in.)	Width (in.)	Thickness (in.)	Hole Dia. (in.)	Fy (ksi)	Fu (ksi)
Plate 1	PL-16	24.0	5.0	0.125	14/16	42.9	61.1
Plate 2	PL-16	24.0	5.0	0.125	14/16	42.9	61.1

TEST RESULTS

Failure Type: Excessive curling of the plates edge

Failure Load: 12000 lbs/plate

Max Deflection $\Delta_{max}= 0.63$ in.

Failure Plate: PL-16

COMMENTS

- * Bolts declined at 6000 lbs.
- * Bulging started at 10000 lbs and 0.03 in.
- * Bulged part curled excessively.

TENSION TESTS ON BOLTED CONNECTIONS

SUMMARY SHEET

Test No: 27

Date: March23, 1995

Test Designation: 1/8x1/4x7/8

Recorder: Burak Karsu

GEOMETRIC AND MATERIAL PROPERTIES

BOLT

Type:A325 Diameter $d_b=0.875$ in. Length $L_b=2.0$ in.

Shear Str. $F_v=72$ ksi Edge Dist. $e=1.5$ in. Fully Pretensioned--Yes

Bolt Hole Fabr.--Drilled

Bolt Hole Type--Standard

Threads in Shear Plane--X

PLATES

<u>No</u>	<u>Designation</u>	<u>Length</u> <u>(in.)</u>	<u>Width</u> <u>(in.)</u>	<u>Thickness</u> <u>(in.)</u>	<u>Hole Dia.</u> <u>(in.)</u>	<u>Fy</u> <u>(ksi)</u>	<u>Fu</u> <u>(ksi)</u>
Plate 1	PL-16	24.0	5.0	0.125	14/16	42.9	61.1
Plate 2	PL-19	24.0	4.0	0.25	14/16	46.9	66.6

TEST RESULTS

Failure Type: Excessive curling of the bulged part.

Failure Load: 16500 lbs/plate

Max Deflection $\Delta_{max}=0.8$ in.

Failure Plate: PL-16

COMMENTS

- * Yielding on PL-16 started at 14000 Lbs.
- * Bulging on PL-16 started at 16000 lbs (0.1 in. of deformation).
- * Yielding on PL-19 started at 16200 lbs
- * Load decreased after 0.2 in. of deformation.

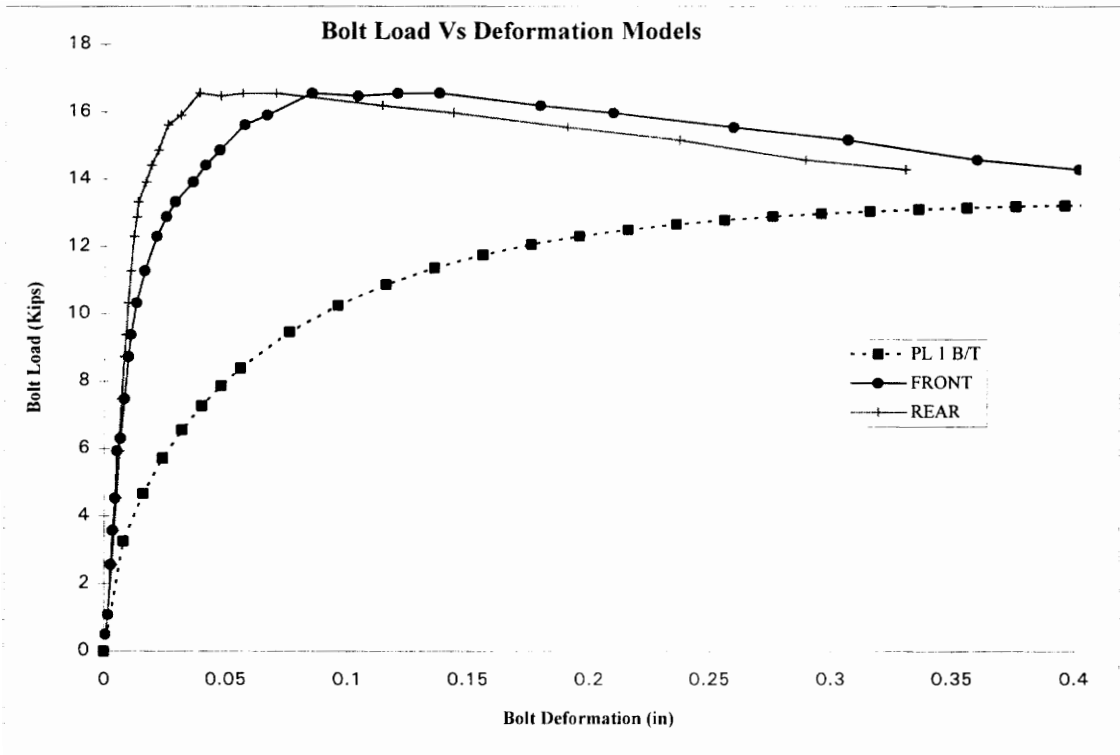

Figure C-27

Plate			Bolt		
	tp	Fu	B/T	Bolt Dia.	A325 0.875
Plate 1	0.125	61.1	13.36	Fv	72
Plate 2	0.25	66.6	29.14	Bolt Shear	43.29

Richard Coefficients

K= 0 Kp= 0 Ro= 0
 K1= 0 n= 0

Data Point	Volts	Load	F1	F2	F3	F4	R1	R2	R3	R4	AVG(F)	AVG(R)
1	0.03	0.50	0.000	0.001	-0.002	-0.002	-0.002	-0.002	0.001	0.001	0.001	0.001
2	0.07	1.10	0.000	0.001	-0.004	-0.004	-0.005	-0.004	0.001	0.001	0.002	0.002
3	0.17	2.56	0.000	0.002	-0.007	-0.006	-0.010	-0.008	0.002	0.002	0.003	0.003
4	0.24	3.59	0.000	0.002	-0.009	-0.007	-0.012	-0.009	0.002	0.003	0.004	0.004
5	0.30	4.54	-0.001	0.002	-0.010	-0.009	-0.015	-0.012	0.002	0.003	0.005	0.005
6	0.40	5.93	0.000	0.001	-0.012	-0.010	-0.017	-0.014	0.002	0.003	0.005	0.006
7	0.42	6.30	-0.001	0.000	-0.013	-0.013	-0.017	-0.013	0.002	0.003	0.007	0.006
8	0.50	7.47	-0.001	-0.001	-0.016	-0.016	-0.018	-0.015	0.001	0.003	0.008	0.007
9	0.58	8.72	-0.001	-0.002	-0.018	-0.018	-0.020	-0.017	0.001	0.002	0.010	0.008
10	0.63	9.38	-0.001	-0.002	-0.020	-0.020	-0.021	-0.018	0.001	0.002	0.011	0.009
11	0.69	10.33	-0.004	-0.004	-0.023	-0.023	-0.023	-0.019	0.001	0.002	0.013	0.010
12	0.75	11.28	-0.006	-0.007	-0.026	-0.026	-0.024	-0.020	0.000	0.002	0.017	0.011
13	0.82	12.30	-0.010	-0.012	-0.031	-0.032	-0.026	-0.022	-0.001	0.001	0.021	0.012
14	0.86	12.89	-0.013	-0.017	-0.034	-0.037	-0.028	-0.024	-0.001	0.001	0.025	0.013
15	0.89	13.33	-0.017	-0.020	-0.037	-0.042	-0.029	-0.024	-0.002	0.001	0.029	0.014
16	0.93	13.92	-0.023	-0.028	-0.045	-0.050	-0.033	-0.028	-0.005	-0.001	0.036	0.017
17	0.96	14.43	-0.028	-0.033	-0.050	-0.055	-0.037	-0.030	-0.007	-0.003	0.041	0.019
18	0.99	14.88	-0.032	-0.040	-0.055	-0.061	-0.040	-0.032	-0.010	-0.005	0.047	0.022
19	1.04	15.61	-0.042	-0.051	-0.064	-0.072	-0.045	-0.036	-0.014	-0.008	0.057	0.026
20	1.06	15.90	-0.050	-0.061	-0.073	-0.083	-0.051	-0.042	-0.020	-0.012	0.067	0.031
21	1.10	16.56	-0.067	-0.081	-0.089	-0.103	-0.059	-0.049	-0.028	-0.019	0.085	0.039
22	1.10	16.48	-0.086	-0.100	-0.107	-0.123	-0.068	-0.058	-0.036	-0.028	0.104	0.047
23	1.10	16.55	-0.102	-0.117	-0.124	-0.139	-0.078	-0.067	-0.045	-0.037	0.120	0.057
24	1.10	16.56	-0.119	-0.135	-0.141	-0.157	-0.091	-0.080	-0.058	-0.051	0.138	0.070
25	1.08	16.19	-0.159	-0.177	-0.182	-0.200	-0.135	-0.125	-0.101	-0.095	0.180	0.114
26	1.07	15.98	-0.190	-0.208	-0.212	-0.230	-0.164	-0.154	-0.131	-0.125	0.210	0.144
27	1.04	15.54	-0.239	-0.258	-0.261	-0.281	-0.212	-0.202	-0.177	-0.173	0.260	0.191
28	1.01	15.17	-0.286	-0.305	-0.308	-0.328	-0.258	-0.249	-0.223	-0.219	0.307	0.237
29	0.97	14.58	-0.339	-0.359	-0.362	-0.381	-0.312	-0.301	-0.275	-0.271	0.360	0.289
30	0.95	14.28	-0.380	-0.400	-0.404	-0.423	-0.352	-0.343	-0.315	-0.311	0.402	0.331

Table C-27

TENSION TESTS ON BOLTED CONNECTIONS

SUMMARY SHEET

Test No: 28

Date: March 23, 1995

Test Designation: 1/8x3/8x7/8

Recorder: Burak Karsu

GEOMETRIC AND MATERIAL PROPERTIES

BOLT

Type:A325

Diameter $d_b=0.875$ in.

Length $L_b= 2.0$ in.

Shear Str. $F_v=72$ ksi

Edge Dist. $e=1.563$ in.

Fully Pretensioned--Yes

Bolt Hole Fabr.--Drilled

Bolt Hole Type--Standard

Threads in Shear Plane--X

PLATES

No	Designation	Length (in.)	Width (in.)	Thickness (in.)	Hole Dia. (in.)	Fy (ksi)	Fu (ksi)
Plate 1	PL-16	24.0	5.0	0.125	14/16	42.9	61.1
Plate 2	PL-23	24.0	4.0	0.325	14/16	43.8	63.8

TEST RESULTS

Failure Type: Bearing / Tear Out

Failure Load: 18500 lbs/plate

Max Deflection $\Delta_{max}= 0.80$ in.

Failure Plate: PL-16

COMMENTS

- * PL-16 yielded at 16000 lbs with 0.025 in. of deformation.
- * PL-19 yielded at 18500 lbs.
- * PL-16 started bulging at 18750 lbs with a deformation of 0.15 in.
- * Connection lost strength after 18750 lbs.

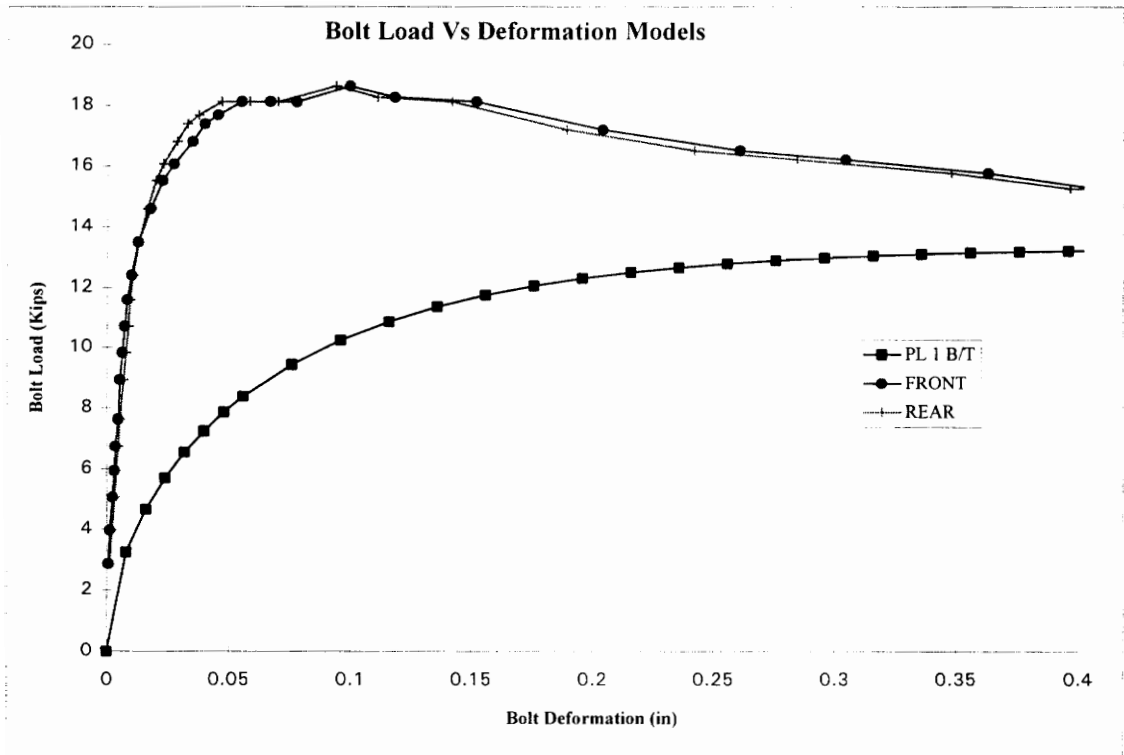

Figure C-28

Plate				Bolt	
	tp	Fu	B/T	Bolt Dia.	A325
Plate 1	0.125	61.1	13.36	Fv	72
Plate 2	0.375	63.8	41.86	Bolt Shear	43.29

Richard Coefficients

K= 0 Kp= 0 Ro= 0
 K1= 0 n= 0

Data Point	Volts	Load	F1	F2	F3	F4	R1	R2	R3	R4	AVG(F)	AVG(R)
1	0.06	2.88	-0.001	0.001	-0.002	-0.001	-0.003	-0.002	0.001	0.000	0.001	0.001
2	0.13	3.98	0.000	0.001	-0.004	-0.002	-0.006	-0.005	0.001	0.001	0.001	0.002
3	0.21	5.08	0.000	0.001	-0.006	-0.005	-0.008	-0.007	0.001	0.001	0.002	0.003
4	0.26	5.96	0.000	0.001	-0.007	-0.007	-0.009	-0.009	0.002	0.001	0.003	0.004
5	0.32	6.76	0.000	0.002	-0.009	-0.007	-0.010	-0.011	0.002	0.001	0.004	0.005
6	0.38	7.64	-0.001	0.002	-0.012	-0.009	-0.012	-0.013	0.003	0.000	0.005	0.006
7	0.46	8.96	-0.002	0.003	-0.013	-0.010	-0.014	-0.017	0.004	-0.001	0.006	0.007
8	0.52	9.84	-0.002	0.003	-0.015	-0.011	-0.015	-0.018	0.003	-0.001	0.006	0.008
9	0.58	10.72	-0.003	0.003	-0.017	-0.012	-0.016	-0.020	0.003	-0.002	0.007	0.009
10	0.64	11.59	-0.004	0.003	-0.019	-0.014	-0.017	-0.021	0.003	-0.002	0.008	0.009
11	0.69	12.40	-0.005	0.002	-0.021	-0.017	-0.019	-0.023	0.003	-0.004	0.010	0.011
12	0.77	13.50	-0.007	0.001	-0.026	-0.019	-0.021	-0.027	0.002	-0.006	0.013	0.013
13	0.84	14.60	-0.012	-0.001	-0.033	-0.024	-0.025	-0.031	-0.001	-0.009	0.018	0.017
14	0.90	15.53	-0.017	-0.006	-0.039	-0.030	-0.028	-0.035	-0.004	-0.013	0.023	0.020
15	0.94	16.07	-0.021	-0.010	-0.043	-0.035	-0.032	-0.039	-0.006	-0.015	0.027	0.023
16	0.99	16.80	-0.028	-0.018	-0.051	-0.043	-0.037	-0.045	-0.010	-0.021	0.035	0.029
17	1.03	17.39	-0.032	-0.022	-0.056	-0.049	-0.042	-0.050	-0.015	-0.025	0.040	0.033
18	1.05	17.68	-0.037	-0.028	-0.062	-0.055	-0.046	-0.055	-0.018	-0.030	0.045	0.037
19	1.07	18.12	-0.046	-0.038	-0.071	-0.065	-0.056	-0.064	-0.028	-0.039	0.055	0.047
20	1.07	18.12	-0.057	-0.050	-0.083	-0.078	-0.068	-0.076	-0.039	-0.050	0.067	0.058
21	1.07	18.11	-0.068	-0.061	-0.093	-0.089	-0.079	-0.088	-0.051	-0.061	0.078	0.070
22	1.11	18.64	-0.090	-0.082	-0.115	-0.112	-0.103	-0.112	-0.076	-0.085	0.100	0.094
23	1.08	18.27	-0.108	-0.100	-0.134	-0.130	-0.120	-0.130	-0.093	-0.102	0.118	0.111
24	1.07	18.12	-0.142	-0.135	-0.168	-0.163	-0.151	-0.161	-0.123	-0.132	0.152	0.142
25	1.01	17.19	-0.194	-0.187	-0.220	-0.216	-0.200	-0.209	-0.169	-0.180	0.204	0.189
26	0.97	16.51	-0.251	-0.244	-0.276	-0.273	-0.253	-0.262	-0.223	-0.232	0.261	0.242
27	0.95	16.22	-0.295	-0.288	-0.319	-0.316	-0.295	-0.305	-0.265	-0.274	0.305	0.285
28	0.92	15.77	-0.353	-0.347	-0.379	-0.375	-0.359	-0.368	-0.328	-0.338	0.363	0.348
29	0.88	15.27	-0.398	-0.391	-0.423	-0.420	-0.407	-0.415	-0.378	-0.386	0.408	0.397
30	0.88	15.27	-0.493	-0.488	-0.520	-0.517	-0.506	-0.515	-0.478	-0.486	0.504	0.496
31	0.85	14.74	-0.631	-0.624	-0.657	-0.655	-0.646	-0.653	-0.617	-0.619	0.642	0.634
32	0.70	12.47	-0.722	-0.716	-0.746	-0.745	-0.722	-0.732	-0.695	-0.698	0.732	0.712
33	0.59	10.79	-0.775	-0.770	-0.796	-0.796	-0.757	-0.766	-0.729	-0.730	0.784	0.746
34	0.51	9.69	-0.805	-0.800	-0.823	-0.825	-0.775	-0.784	-0.747	-0.746	0.813	0.763

Table C-28

TENSION TESTS ON BOLTED CONNECTIONS

SUMMARY SHEET

Test No: 29

Date: March 24, 1995

Test Designation: 1/8x1/2x7/8

Recorder: Burak Karsu

GEOMETRIC AND MATERIAL PROPERTIES

BOLT

Type:A325 Diameter $d_b=0.875$ in. Length $L_b=2.0$ in.

Shear Str. $F_v=72$ ksi Edge Dist. $e=1.625$ in. Fully Pretensioned--Yes

Bolt Hole Fabr.--Drilled

Bolt Hole Type--Standard

Threads in Shear Plane--X

PLATES

<u>No</u>	<u>Designation</u>	<u>Length</u> <u>(in.)</u>	<u>Width</u> <u>(in.)</u>	<u>Thickness</u> <u>(in.)</u>	<u>Hole Dia.</u> <u>(in.)</u>	<u>Fy</u> <u>(ksi)</u>	<u>Fu</u> <u>(ksi)</u>
Plate 1	PL-16	24.0	5.0	0.125	14/16	42.9	61.1
Plate 2	PL-34	24.0	4.0	0.5	14/16	51.8	73.8

TEST RESULTS

Failure Type: Excessive curling of the bulged part.

Failure Load: 19500 lbs/plate

Max Deflection $\Delta_{max}=0.66$ in.

Failure Plate: PL-16

COMMENTS

* Yielding on PL-16 started at 17000 lbs with 0.03 in. of deformation.

* Load capacity decreased at 0.17 in. of deformation.

* Bulged part bent out of plane at 0.2 in.

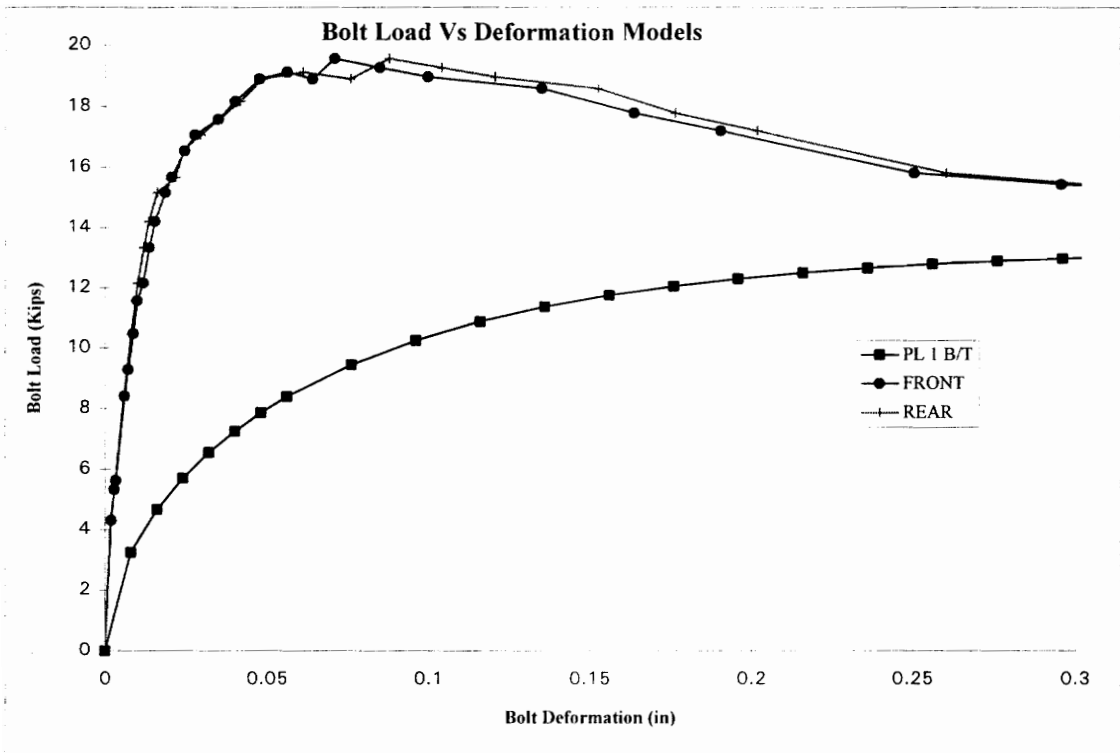

Figure C-29

Plate			Bolt		
	tp	Fu	B/T	Bolt Dia.	A325
Plate 1	0.125	61.1	13.36	Fv	72
Plate 2	0.5	73.8	64.58	Bolt Shear	43.29

Richard Coefficients

$K = 19333$ $K_p = 20$ $R_o = 50$
 $K_1 = 19313$ $n = 0.5$

Data Point	Vols	Load	F1	F2	F3	F4	R1	R2	R3	R4	AVG(F)	AVG(R)
1	0.00	0.00	0.000	0.000	0.000	0.000	0.000	0.000	0.000	0.000	0.000	0.000
3	0.10	4.31	0.000	0.000	-0.005	-0.003	-0.004	-0.004	0.001	0.001	0.002	0.002
4	0.17	5.33	0.000	0.001	-0.007	-0.006	-0.008	-0.006	0.001	0.001	0.003	0.003
5	0.19	5.63	-0.001	0.002	-0.009	-0.006	-0.009	-0.007	0.002	0.002	0.003	0.003
6	0.37	8.42	-0.002	0.004	-0.017	-0.010	-0.017	-0.013	0.004	0.004	0.006	0.006
7	0.43	9.30	-0.002	0.005	-0.020	-0.011	-0.019	-0.015	0.004	0.004	0.007	0.007
8	0.51	10.47	-0.004	0.007	-0.024	-0.013	-0.023	-0.017	0.003	0.004	0.009	0.008
9	0.58	11.57	-0.006	0.008	-0.029	-0.013	-0.026	-0.018	0.002	0.005	0.010	0.009
10	0.62	12.15	-0.009	0.009	-0.034	-0.014	-0.028	-0.018	0.001	0.005	0.012	0.010
11	0.70	13.32	-0.012	0.011	-0.039	-0.015	-0.032	-0.020	-0.001	0.005	0.014	0.012
12	0.76	14.20	-0.014	0.011	-0.043	-0.015	-0.034	-0.021	-0.003	0.005	0.015	0.013
13	0.82	15.15	-0.020	0.012	-0.050	-0.017	-0.039	-0.023	-0.007	0.005	0.018	0.016
14	0.85	15.67	-0.023	0.012	-0.054	-0.017	-0.045	-0.028	-0.014	0.001	0.020	0.022
15	0.91	16.55	-0.028	0.010	-0.061	-0.019	-0.050	-0.029	-0.017	0.000	0.024	0.024
16	0.95	17.06	-0.032	0.009	-0.066	-0.021	-0.057	-0.034	-0.023	-0.004	0.028	0.029
17	0.98	17.57	-0.041	0.004	-0.076	-0.027	-0.064	-0.039	-0.030	-0.009	0.035	0.035
18	1.02	18.17	-0.046	0.001	-0.083	-0.032	-0.071	-0.045	-0.037	-0.013	0.040	0.042
19	1.07	18.90	-0.054	-0.006	-0.092	-0.038	-0.079	-0.052	-0.044	-0.019	0.048	0.048
20	1.08	19.12	-0.064	-0.013	-0.102	-0.045	-0.093	-0.063	-0.057	-0.031	0.056	0.061
21	1.07	18.90	-0.073	-0.019	-0.111	-0.053	-0.108	-0.076	-0.074	-0.045	0.064	0.076
22	1.11	19.56	-0.080	-0.024	-0.120	-0.059	-0.120	-0.088	-0.087	-0.056	0.071	0.088
23	1.09	19.27	-0.094	-0.038	-0.134	-0.073	-0.136	-0.104	-0.103	-0.072	0.085	0.104
24	1.07	18.97	-0.108	-0.053	-0.149	-0.088	-0.153	-0.121	-0.120	-0.088	0.100	0.121
25	1.05	18.60	-0.143	-0.089	-0.184	-0.124	-0.185	-0.153	-0.152	-0.121	0.135	0.153
26	1.00	17.79	-0.173	-0.119	-0.212	-0.152	-0.209	-0.177	-0.174	-0.146	0.164	0.176
27	0.96	17.21	-0.201	-0.147	-0.237	-0.178	-0.234	-0.203	-0.200	-0.172	0.191	0.202
28	0.86	15.81	-0.261	-0.208	-0.297	-0.236	-0.292	-0.260	-0.259	-0.230	0.250	0.260
29	0.84	15.45	-0.306	-0.253	-0.342	-0.281	-0.337	-0.304	-0.303	-0.274	0.296	0.304
30	0.80	14.86	-0.416	-0.363	-0.449	-0.390	-0.443	-0.410	-0.409	-0.382	0.404	0.411
31	0.76	14.28	-0.509	-0.462	-0.545	-0.484	-0.537	-0.504	-0.506	-0.475	0.500	0.506
32	0.74	13.98	-0.623	-0.573	-0.655	-0.595	-0.648	-0.614	-0.620	-0.590	0.611	0.618
33	0.71	13.54	-0.665	-0.615	-0.697	-0.636	-0.691	-0.657	-0.666	-0.634	0.653	0.662

Table C-29

TENSION TESTS ON BOLTED CONNECTIONS

SUMMARY SHEET

Test No: 30

Date: March 24, 1995

Test Designation: 1/8x3/4x7/8

Recorder: Burak Karsu

GEOMETRIC AND MATERIAL PROPERTIES

BOLT

Type:A325

Diameter $d_b=0.875$ in.

Length $L_b= 2.25$ in.

Shear Str. $F_v=72$ ksi

Edge Dist. $e=1.625$ in.

Fully Pretensioned--Yes

Bolt Hole Fabr.--Drilled

Bolt Hole Type--Standard

Threads in Shear Plane--X

PLATES

No	Designation	Length (in.)	Width (in.)	Thickness (in.)	Hole Dia. (in.)	Fy (ksi)	Fu (ksi)
Plate 1	PL-15	24.0	5.0	0.125	14/16	43.2	61.4
Plate 2	PL-28	24.0	4.0	0.75	14/16	44.8	69.0

TEST RESULTS

Failure Type: Bearing / Tear Out

Failure Load: 17000 lbs/plate

Max Deflection $\Delta_{max}=0.60$ in.

Failure Plate: PL-15

COMMENTS

* PL-15 yielded at 15500 lbs with a deformation of 0.03 in.

* Strength loss observed after 0.25 in. of deformation.

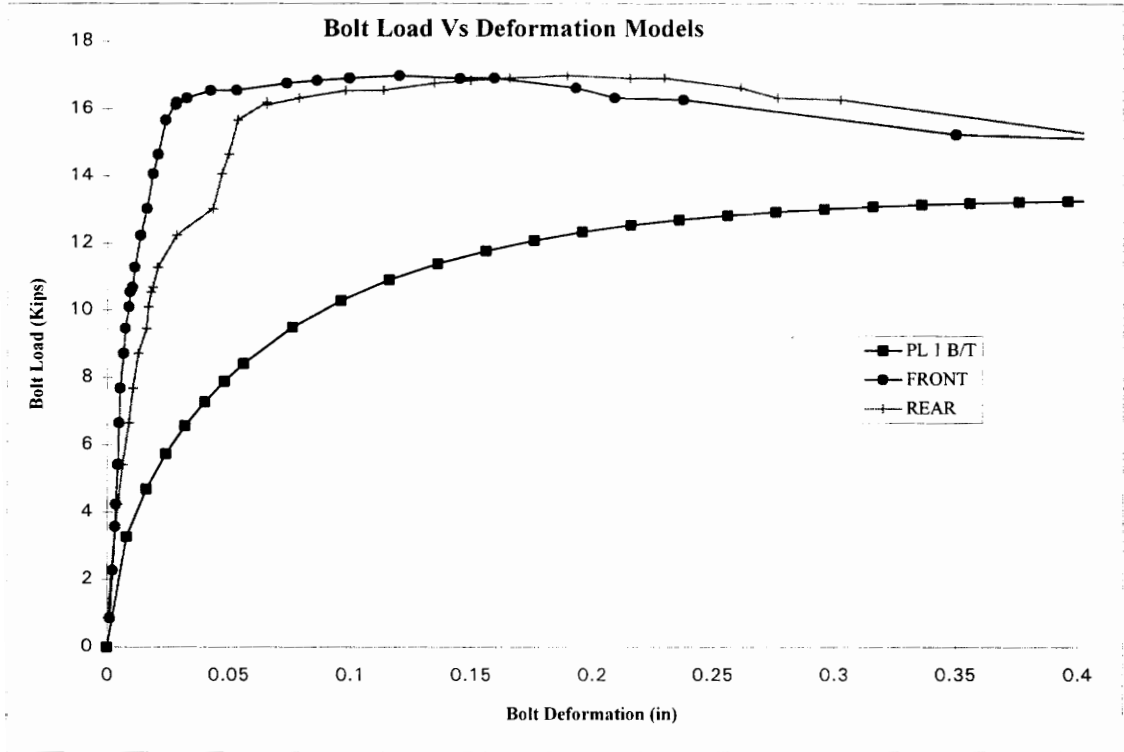

Figure C-30

Plate				Bolt	
	tp	Fu	B/T	Bolt Dia.	A325
Plate 1	0.125	61.3	13.41	Fv	72
Plate 2	0.75	64	90.56	Bolt Shear	43.29

Richard Coefficients

K= 0 Kp= 0 Ro= 0
 K1= 0 n= 0

Data Point	Volts	Load	F1	F2	F3	F4	R1	R2	R3	R4	AVG(F)	AVG(R)
1	0.06	0.88	-0.001	0.001	-0.002	-0.002	-0.001	-0.001	0.000	0.000	0.001	0.000
2	0.15	2.27	0.000	0.000	-0.004	-0.005	-0.004	-0.004	0.000	0.001	0.002	0.002
3	0.24	3.59	0.000	-0.001	-0.006	-0.007	-0.008	-0.007	0.001	0.001	0.003	0.004
4	0.28	4.25	0.000	-0.001	-0.006	-0.008	-0.010	-0.010	0.002	0.001	0.004	0.004
5	0.36	5.42	0.000	-0.001	-0.007	-0.010	-0.014	-0.015	0.002	0.001	0.004	0.006
6	0.44	6.67	0.000	-0.002	-0.006	-0.011	-0.020	-0.022	0.004	0.002	0.005	0.009
7	0.51	7.69	0.001	-0.003	-0.007	-0.012	-0.024	-0.028	0.006	0.003	0.005	0.011
8	0.58	8.72	0.001	-0.004	-0.009	-0.015	-0.025	-0.034	0.008	0.001	0.007	0.013
9	0.63	9.45	0.001	-0.003	-0.011	-0.017	-0.027	-0.040	0.008	-0.004	0.007	0.016
10	0.67	10.11	0.000	-0.002	-0.015	-0.018	-0.028	-0.042	0.009	-0.006	0.009	0.017
11	0.70	10.55	0.000	-0.002	-0.016	-0.020	-0.029	-0.045	0.009	-0.006	0.009	0.018
12	0.71	10.69	-0.001	-0.002	-0.018	-0.021	-0.029	-0.045	0.008	-0.008	0.010	0.019
13	0.75	11.28	-0.001	-0.002	-0.020	-0.021	-0.031	-0.049	0.007	-0.010	0.011	0.021
14	0.82	12.23	-0.005	-0.001	-0.025	-0.023	-0.038	-0.059	0.002	-0.018	0.014	0.028
15	0.87	13.04	-0.007	0.000	-0.031	-0.026	-0.052	-0.075	-0.012	-0.034	0.016	0.043
16	0.94	14.06	-0.012	0.000	-0.035	-0.028	-0.057	-0.080	-0.013	-0.037	0.019	0.047
17	0.98	14.66	-0.015	-0.001	-0.039	-0.029	-0.061	-0.084	-0.015	-0.039	0.021	0.050
18	1.04	15.67	-0.017	-0.002	-0.043	-0.032	-0.066	-0.090	-0.018	-0.040	0.024	0.054
19	1.08	16.20	-0.022	-0.006	-0.050	-0.036	-0.078	-0.102	-0.029	-0.053	0.028	0.065
20	1.07	16.12	-0.022	-0.006	-0.049	-0.036	-0.078	-0.102	-0.029	-0.053	0.028	0.065
21	1.09	16.33	-0.026	-0.009	-0.054	-0.040	-0.090	-0.115	-0.043	-0.067	0.033	0.079
22	1.10	16.55	-0.035	-0.018	-0.065	-0.051	-0.109	-0.135	-0.062	-0.086	0.042	0.098
23	1.10	16.56	-0.045	-0.029	-0.075	-0.062	-0.125	-0.150	-0.077	-0.102	0.053	0.114
24	1.12	16.77	-0.067	-0.049	-0.097	-0.083	-0.146	-0.171	-0.098	-0.122	0.074	0.134
25	1.12	16.85	-0.079	-0.061	-0.109	-0.095	-0.161	-0.187	-0.113	-0.138	0.086	0.150
26	1.13	16.93	-0.092	-0.074	-0.124	-0.109	-0.178	-0.203	-0.129	-0.154	0.100	0.166
27	1.13	17.00	-0.112	-0.094	-0.144	-0.130	-0.201	-0.227	-0.153	-0.178	0.120	0.190
28	1.13	16.92	-0.137	-0.120	-0.168	-0.155	-0.226	-0.253	-0.179	-0.204	0.145	0.216
29	1.13	16.93	-0.151	-0.135	-0.183	-0.169	-0.240	-0.267	-0.193	-0.219	0.159	0.230
30	1.11	16.64	-0.186	-0.168	-0.216	-0.203	-0.272	-0.300	-0.224	-0.250	0.193	0.261
31	1.09	16.33	-0.202	-0.184	-0.232	-0.218	-0.286	-0.314	-0.240	-0.265	0.209	0.277
32	1.08	16.27	-0.231	-0.213	-0.260	-0.247	-0.313	-0.341	-0.266	-0.290	0.238	0.303
33	1.02	15.24	-0.344	-0.327	-0.371	-0.360	-0.418	-0.446	-0.373	-0.394	0.350	0.408
34	0.99	14.87	-0.519	-0.505	-0.542	-0.534	-0.590	-0.618	-0.546	-0.569	0.525	0.581
35	0.94	14.06	-0.603	-0.591	-0.624	-0.618	-0.676	-0.705	-0.638	-0.663	0.609	0.671
36	0.83	12.39	-0.700	-0.687	-0.716	-0.708	-0.765	-0.791	-0.731	-0.753	0.703	0.760

Table C-30

TENSION TESTS ON BOLTED CONNECTIONS

SUMMARY SHEET

Test No: 31

Date: March 25, 1995

Test Designation: 1/4x1/4x7/8

Recorder: Burak Karsu

GEOMETRIC AND MATERIAL PROPERTIES

BOLT

Type: A325 Diameter $d_b=0.875$ in. Length $L_b=2.0$ in.

Shear Str. $F_v=72$ ksi Edge Dist. $e=1.75$ in. Fully Pretensioned--Yes

Bolt Hole Fabr.--Drilled

Bolt Hole Type--Standard

Threads in Shear Plane--X

PLATES

No	Designation	Length (in.)	Width (in.)	Thickness (in.)	Hole Dia. (in.)	Fy (ksi)	Fu (ksi)
Plate 1	PL-20	24.0	4.0	0.25	15/16	46.1	66.2
Plate 2	PL-20	24.0	4.0	0.25	15/16	46.1	66.2

TEST RESULTS

Failure Type: Bearing / Tear Out

Failure Load: 27500 lbs/plate

Max Deflection $\Delta_{max}=1.0$ in.

Failure Plate: PL-20

COMMENTS

* Yielding on PL-20 started at 19000 lbs with a deformation of 0.04 in.

* Bulging started at 24000 lbs (0.15 in.).

* Strength of the connection increased.

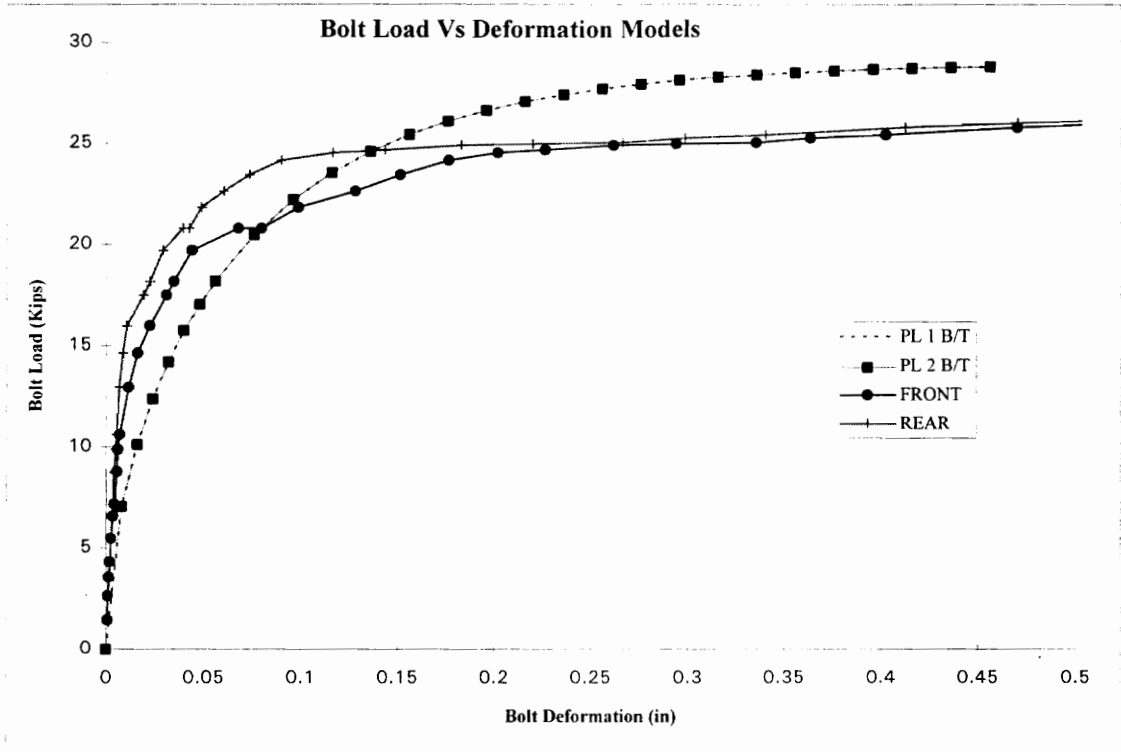

Figure C-31

Plate				Bolt	A325
	tp	Fu	B/T	Bolt Dia.	0.875
Plate 1	0.25	66.2	28.96	Fv	72
Plate 2	0.25	66.2	28.96	Bolt Shear	43.29

Richard Coefficients

K= 0 Kp= 0 Ro= 0
 K1= 0 n= 0

Data Point	Volts	Load	F1	F2	F3	F4	R1	R2	R3	R4	AVG(F)	AVG(R)
1	0.06	1.46	-0.001	-0.001	-0.001	-0.001	-0.001	0.000	0.000	-0.001	0.001	0.000
2	0.14	2.63	-0.001	-0.001	-0.001	-0.001	-0.002	-0.001	-0.001	-0.001	0.001	0.001
3	0.21	3.59	-0.001	-0.001	-0.002	-0.002	-0.003	-0.002	-0.001	-0.001	0.002	0.002
4	0.25	4.32	-0.002	-0.001	-0.003	-0.002	-0.004	-0.003	-0.002	-0.001	0.002	0.002
5	0.33	5.49	-0.003	-0.001	-0.004	-0.002	-0.005	-0.002	-0.002	-0.001	0.003	0.003
6	0.41	6.59	-0.005	-0.002	-0.004	-0.004	-0.006	-0.002	-0.003	-0.001	0.004	0.003
7	0.44	7.17	-0.006	-0.003	-0.005	-0.004	-0.007	-0.002	-0.004	-0.001	0.004	0.004
8	0.55	8.79	-0.007	-0.004	-0.006	-0.006	-0.008	-0.003	-0.004	-0.001	0.006	0.004
9	0.63	9.88	-0.007	-0.005	-0.007	-0.006	-0.009	-0.004	-0.006	-0.002	0.006	0.005
10	0.67	10.62	-0.008	-0.006	-0.008	-0.007	-0.009	-0.004	-0.006	-0.003	0.007	0.006
11	0.83	12.96	-0.012	-0.010	-0.012	-0.012	-0.010	-0.007	-0.006	-0.004	0.012	0.007
12	0.94	14.64	-0.015	-0.017	-0.015	-0.018	-0.011	-0.009	-0.008	-0.007	0.016	0.009
13	1.03	15.97	-0.018	-0.025	-0.020	-0.026	-0.012	-0.012	-0.009	-0.009	0.022	0.011
14	1.13	17.50	-0.024	-0.037	-0.026	-0.037	-0.022	-0.020	-0.019	-0.017	0.031	0.019
15	1.18	18.16	-0.028	-0.042	-0.029	-0.042	-0.026	-0.022	-0.023	-0.018	0.035	0.022
16	1.28	19.71	-0.034	-0.053	-0.036	-0.053	-0.035	-0.026	-0.032	-0.023	0.044	0.029
17	1.35	20.81	-0.057	-0.078	-0.057	-0.078	-0.049	-0.034	-0.045	-0.029	0.068	0.039
18	1.35	20.81	-0.068	-0.091	-0.069	-0.091	-0.053	-0.036	-0.050	-0.032	0.080	0.043
19	1.42	21.83	-0.086	-0.110	-0.087	-0.112	-0.061	-0.040	-0.057	-0.036	0.099	0.049
20	1.48	22.64	-0.114	-0.141	-0.115	-0.143	-0.075	-0.050	-0.071	-0.046	0.128	0.060
21	1.53	23.44	-0.135	-0.165	-0.139	-0.166	-0.088	-0.062	-0.085	-0.058	0.151	0.073
22	1.58	24.18	-0.160	-0.191	-0.163	-0.193	-0.105	-0.078	-0.102	-0.074	0.176	0.090
23	1.60	24.54	-0.184	-0.218	-0.188	-0.217	-0.132	-0.105	-0.129	-0.100	0.202	0.116
24	1.61	24.69	-0.209	-0.243	-0.212	-0.242	-0.160	-0.131	-0.156	-0.127	0.226	0.143
25	1.63	24.91	-0.242	-0.280	-0.247	-0.278	-0.199	-0.171	-0.195	-0.167	0.262	0.183
26	1.63	24.98	-0.275	-0.312	-0.278	-0.312	-0.237	-0.207	-0.233	-0.203	0.294	0.220
27	1.64	25.05	-0.316	-0.354	-0.319	-0.355	-0.283	-0.253	-0.280	-0.250	0.336	0.266
28	1.65	25.27	-0.342	-0.382	-0.347	-0.383	-0.316	-0.284	-0.313	-0.282	0.364	0.299
29	1.66	25.42	-0.381	-0.422	-0.385	-0.421	-0.358	-0.326	-0.355	-0.324	0.402	0.340
30	1.69	25.79	-0.447	-0.491	-0.452	-0.489	-0.430	-0.398	-0.426	-0.395	0.470	0.412
31	1.70	26.01	-0.500	-0.545	-0.504	-0.545	-0.490	-0.456	-0.483	-0.452	0.524	0.470
32	1.72	26.30	-0.584	-0.631	-0.589	-0.631	-0.584	-0.550	-0.576	-0.546	0.609	0.564
33	1.74	26.67	-0.684	-0.737	-0.691	-0.737	-0.700	-0.666	-0.689	-0.659	0.712	0.679
34	1.77	27.11	-0.780	-0.836	-0.789	-0.836	-0.805	-0.771	-0.793	-0.763	0.810	0.783
35	1.80	27.47	-0.882	-0.939	-0.892	-0.940	-0.912	-0.875	-0.898	-0.866	0.913	0.888
36	1.81	27.69	-0.982	-1.042	-0.992	-1.040	-1.016	-0.979	-1.003	-0.971	1.014	0.992
37	1.95	29.82	-1.066	-1.126	-1.074	-1.123	-1.103	-1.066	-1.089	-1.058	1.097	1.079
38	1.98	30.18	-1.152	-1.214	-1.160	-1.211	-1.201	-1.161	-1.185	-1.154	1.185	1.175
39	1.90	29.01	-1.159	-1.222	-1.169	-1.219	-1.210	-1.171	-1.195	-1.163	1.192	1.185

Table C-31

TENSION TESTS ON BOLTED CONNECTIONS

SUMMARY SHEET

Test No: 32

Date: March 24, 1995

Test Designation: 1/4x3/8x7/8

Recorder: Burak Karsu

GEOMETRIC AND MATERIAL PROPERTIES

BOLT

Type: A325 Diameter $d_b=0.875$ in. Length $L_b=2.0$ in.

Shear Str. $F_v=72$ ksi Edge Dist. $e=1.75$ in. Fully Pretensioned--Yes

Bolt Hole Fabr.--Drilled

Bolt Hole Type--Standard

Threads in Shear Plane--X

PLATES

<u>No</u>	<u>Designation</u>	<u>Length</u> <u>(in.)</u>	<u>Width</u> <u>(in.)</u>	<u>Thickness</u> <u>(in.)</u>	<u>Hole Dia.</u> <u>(in.)</u>	<u>Fy</u> <u>(ksi)</u>	<u>Fu</u> <u>(ksi)</u>
Plate 1	PL-20	24.0	4.0	0.25	15/16	46.1	66.2
Plate 2	PL-22	24.0	4.0	0.375	15/16	43.4	63.8

TEST RESULTS

Failure Type: Splitting in the bulged part

Failure Load: 27500 lbs/plate

Max Deflection $\Delta_{max}=0.8$ in.

Failure Plate: PL-20

COMMENTS

- * PL-20 yielded at 0.04 in of deformation with a load of 20800 lbs.
- * Excessive deformations started at 23000 lbs.
- * PL-20 bulged at 27000 lbs and 0.15 in. of deformation.
- * PL-22 bulged at 27500 lbs and 0.3 in. of deformation.
- * Splitting occurred at 0.80 in. of deformation.

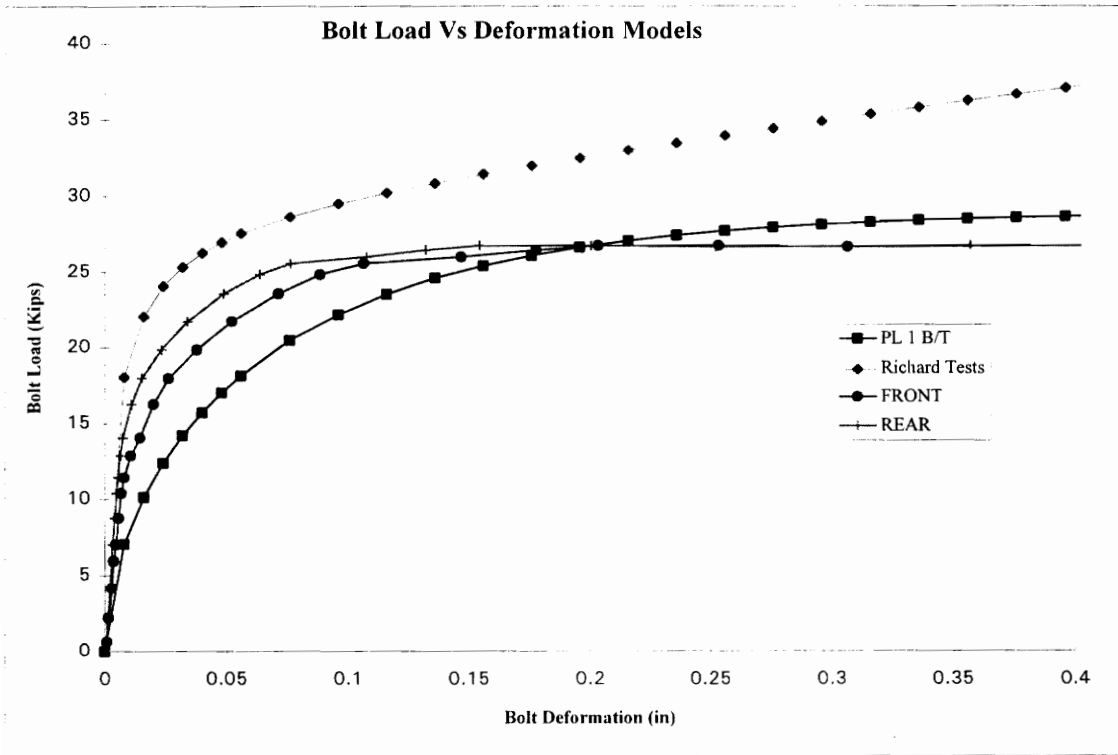

Figure C-32

Plate	tp	Fu	B/T	Bolt	A325
Plate 1	0.25	66.2	28.96	Bolt Dia.	0.875
Plate 2	0.375	63.8	41.87	Fv	72
				Bolt Shear	43.29

Richard Coefficients

K= 8700 Kp= 20 Ro= 30
 K1= 8680 n= 0.8

Data Point	Volts	Load	F1	F2	F3	F4	R1	R2	R3	R4	AVG(F)	AVG(R)
1	0.04	0.65	0.000	0.001	-0.002	-0.002	-0.001	-0.001	-0.001	0.000	0.001	0.001
2	0.15	2.20	0.000	0.001	-0.004	-0.003	-0.003	-0.002	-0.001	0.000	0.002	0.001
3	0.28	4.17	0.000	0.000	-0.007	-0.005	-0.005	-0.003	-0.001	0.000	0.003	0.002
4	0.40	5.93	-0.001	0.000	-0.008	-0.006	-0.006	-0.004	-0.001	0.000	0.004	0.003
5	0.47	7.03	0.000	-0.001	-0.010	-0.008	-0.006	-0.005	-0.002	0.000	0.005	0.003
6	0.59	8.79	0.000	-0.001	-0.012	-0.010	-0.008	-0.006	-0.002	-0.001	0.006	0.004
7	0.69	10.40	0.000	-0.002	-0.013	-0.012	-0.009	-0.007	-0.002	-0.001	0.007	0.005
8	0.76	11.43	-0.001	-0.002	-0.015	-0.014	-0.010	-0.007	-0.004	-0.001	0.008	0.006
9	0.86	12.89	-0.002	-0.005	-0.018	-0.018	-0.010	-0.010	-0.004	-0.002	0.011	0.006
10	0.94	14.06	-0.004	-0.009	-0.022	-0.023	-0.010	-0.012	-0.003	-0.004	0.015	0.007
11	1.08	16.26	-0.008	-0.015	-0.027	-0.031	-0.014	-0.018	-0.004	-0.009	0.020	0.011
12	1.20	18.02	-0.013	-0.021	-0.032	-0.039	-0.018	-0.023	-0.007	-0.013	0.026	0.015
13	1.32	19.86	-0.021	-0.035	-0.042	-0.053	-0.028	-0.032	-0.013	-0.020	0.038	0.023
14	1.45	21.76	-0.032	-0.051	-0.056	-0.069	-0.040	-0.045	-0.023	-0.028	0.052	0.034
15	1.57	23.59	-0.050	-0.071	-0.074	-0.091	-0.057	-0.060	-0.036	-0.042	0.071	0.049
16	1.66	24.84	-0.067	-0.088	-0.090	-0.109	-0.072	-0.075	-0.051	-0.056	0.089	0.064
17	1.70	25.57	-0.085	-0.106	-0.108	-0.127	-0.085	-0.088	-0.063	-0.069	0.107	0.076
18	1.73	26.01	-0.124	-0.147	-0.149	-0.167	-0.117	-0.120	-0.094	-0.100	0.147	0.108
19	1.76	26.45	-0.155	-0.177	-0.181	-0.198	-0.141	-0.146	-0.117	-0.124	0.178	0.132
20	1.78	26.74	-0.181	-0.203	-0.206	-0.225	-0.163	-0.168	-0.140	-0.147	0.204	0.154
21	1.78	26.74	-0.230	-0.253	-0.256	-0.275	-0.210	-0.214	-0.186	-0.192	0.254	0.201
22	1.78	26.67	-0.282	-0.306	-0.310	-0.329	-0.261	-0.266	-0.237	-0.244	0.307	0.252
23	1.78	26.74	-0.385	-0.410	-0.416	-0.436	-0.365	-0.373	-0.343	-0.348	0.412	0.357
24	1.78	26.67	-0.490	-0.517	-0.525	-0.546	-0.476	-0.483	-0.450	-0.455	0.519	0.466
25	1.79	26.82	-0.589	-0.615	-0.625	-0.645	-0.576	-0.584	-0.550	-0.554	0.619	0.566
26	1.82	27.33	-0.684	-0.709	-0.718	-0.741	-0.672	-0.680	-0.643	-0.648	0.713	0.661
27	1.82	27.26	-0.792	-0.820	-0.826	-0.851	-0.758	-0.768	-0.730	-0.734	0.822	0.747

Table C-32

TENSION TESTS ON BOLTED CONNECTIONS

SUMMARY SHEET

Test No: 33

Date: March 25, 1995

Test Designation: 1/4x1/2x7/8

Recorder: Burak Karsu

GEOMETRIC AND MATERIAL PROPERTIES

BOLT

Type: A325 Diameter $d_b=0.875$ in. Length $L_b=2.25$ in.

Shear Str. $F_v=72$ ksi Edge Dist. $e=1.75$ in. Fully Pretensioned--Yes

Bolt Hole Fabr.--Drilled

Bolt Hole Type--Standard

Threads in Shear Plane--X

PLATES

No	Designation	Length (in.)	Width (in.)	Thickness (in.)	Hole Dia. (in.)	Fy (ksi)	Fu (ksi)
Plate 1	PL-20	24.0	4.0	0.25	15/16	46.1	66.2
Plate 2	PL-34	24.0	4.0	0.5	15/16	51.8	73.8

TEST RESULTS

Failure Type: Bearing / Tear Out

Failure Load: 30000 lbs/plate

Max Deflection $\Delta_{max}=0.65$ in.

Failure Plate: PL-20

COMMENTS

* Yielding on PL-20 started at 20500 lbs and 0.02 in. of deformation.

* PL-34 yielded at 0.4 in.

* PL-20 torn out at 0.65 in.

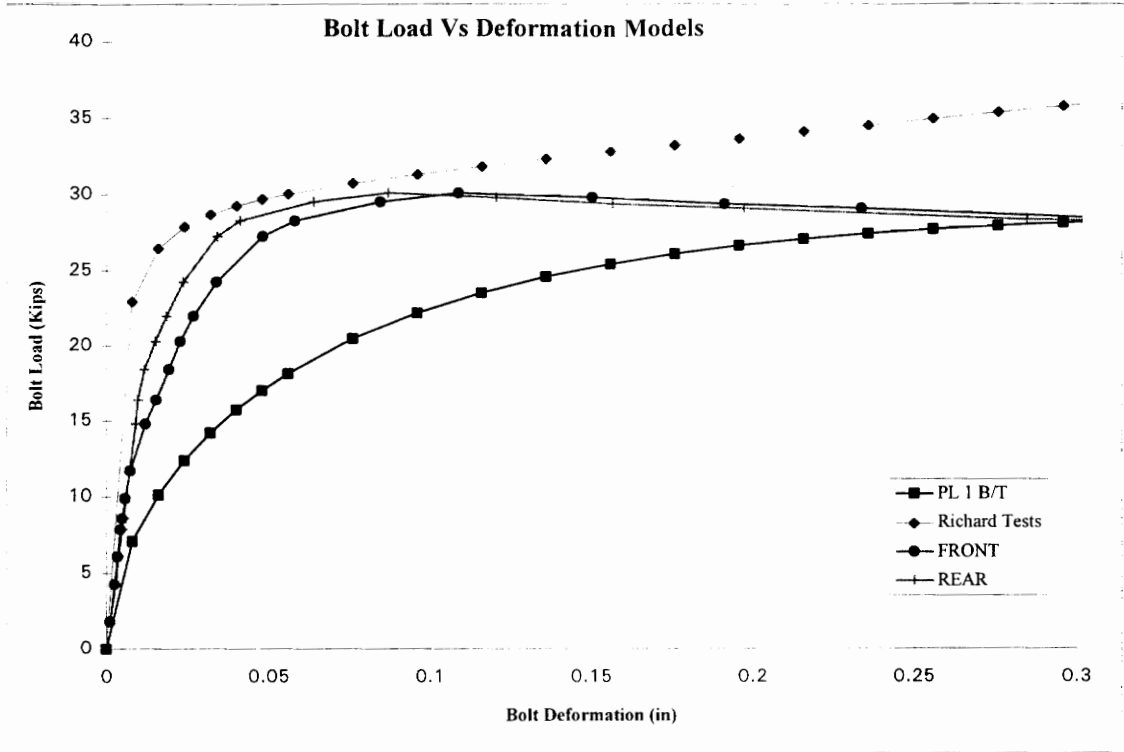

Figure C-33

Plate				Bolt	A325
	tp	Fu	B/T	Bolt Dia.	0.875
Plate 1	0.25	66.2	28.96	Fv	72
Plate 2	0.5	73.8	64.58	Bolt Shear	43.29

Richard Coefficients

K= 9667 Kp= 20 Ro= 30
 K1= 9647 n= 1.1

Data Point	Volts	Load	F1	F2	F3	F4	R1	R2	R3	R4	AVG(F)	AVG(R)
1	0.12	1.83	-0.001	0.000	-0.002	-0.002	-0.003	-0.002	0.000	0.001	0.001	0.001
2	0.28	4.25	-0.001	-0.001	-0.004	-0.005	-0.007	-0.006	0.000	0.001	0.003	0.003
3	0.41	6.08	-0.001	-0.001	-0.006	-0.007	-0.010	-0.007	0.001	0.001	0.004	0.004
4	0.52	7.84	-0.001	-0.001	-0.007	-0.009	-0.012	-0.009	0.001	0.001	0.004	0.005
5	0.57	8.57	-0.001	-0.001	-0.009	-0.010	-0.013	-0.010	0.001	0.001	0.005	0.005
6	0.66	9.89	0.000	-0.001	-0.010	-0.012	-0.013	-0.012	0.001	0.000	0.006	0.006
7	0.78	11.72	0.002	-0.002	-0.012	-0.017	-0.015	-0.015	0.001	0.000	0.007	0.007
8	0.99	14.79	0.003	-0.007	-0.016	-0.028	-0.018	-0.018	0.001	-0.002	0.012	0.009
9	1.09	16.41	0.004	-0.012	-0.018	-0.035	-0.019	-0.018	0.001	-0.002	0.015	0.010
10	1.23	18.46	0.004	-0.017	-0.021	-0.043	-0.023	-0.022	0.001	-0.003	0.019	0.012
11	1.35	20.30	0.005	-0.023	-0.023	-0.051	-0.028	-0.026	-0.002	-0.004	0.023	0.015
12	1.47	21.98	0.005	-0.029	-0.024	-0.059	-0.034	-0.029	-0.006	-0.006	0.027	0.018
13	1.62	24.25	0.004	-0.039	-0.029	-0.072	-0.042	-0.034	-0.011	-0.008	0.034	0.024
14	1.82	27.26	-0.004	-0.055	-0.041	-0.093	-0.058	-0.043	-0.021	-0.013	0.048	0.034
15	1.89	28.28	-0.010	-0.067	-0.050	-0.105	-0.068	-0.050	-0.029	-0.018	0.058	0.041
16	1.97	29.53	-0.034	-0.094	-0.076	-0.135	-0.095	-0.073	-0.050	-0.037	0.085	0.064
17	2.01	30.11	-0.056	-0.118	-0.100	-0.162	-0.120	-0.097	-0.072	-0.059	0.109	0.087
18	1.99	29.82	-0.096	-0.160	-0.141	-0.205	-0.155	-0.131	-0.105	-0.092	0.150	0.121
19	1.96	29.38	-0.136	-0.201	-0.182	-0.247	-0.192	-0.168	-0.140	-0.127	0.192	0.157
20	1.94	29.09	-0.179	-0.243	-0.224	-0.289	-0.234	-0.210	-0.180	-0.167	0.234	0.198
21	1.89	28.35	-0.264	-0.329	-0.310	-0.377	-0.322	-0.296	-0.267	-0.254	0.320	0.285
22	1.88	28.13	-0.348	-0.417	-0.400	-0.466	-0.414	-0.388	-0.358	-0.343	0.408	0.376
23	1.90	28.50	-0.449	-0.516	-0.502	-0.565	-0.517	-0.492	-0.458	-0.445	0.508	0.478
24	1.91	28.72	-0.520	-0.589	-0.577	-0.641	-0.592	-0.565	-0.531	-0.516	0.582	0.551

Table C-33

TENSION TESTS ON BOLTED CONNECTIONS

SUMMARY SHEET

Test No: 34

Date: March 25, 1995

Test Designation: 1/4x3/4x7/8

Recorder: Burak Karsu

GEOMETRIC AND MATERIAL PROPERTIES

BOLT

Type:A325 Diameter $d_b=0.875$ in. Length $L_b=2.5$ in.

Shear Str. $F_v=72$ ksi Edge Dist. $e=1.75$ in. Fully Pretensioned--Yes

Bolt Hole Fabr.--Drilled

Bolt Hole Type--Standard

Threads in Shear Plane--X

PLATES

No	Designation	Length (in.)	Width (in.)	Thickness (in.)	Hole Dia. (in.)	Fy (ksi)	Fu (ksi)
Plate 1	PL-20	24.0	4.0	0.25	15/16	46.1	66.2
Plate 2	PL-29	24.0	4.0	0.75	15/16	44.6	69.9

TEST RESULTS

Failure Type: Bearing /Tear Out

Failure Load: 28130 lbs/plate

Max Deflection $\Delta_{max}=0.60$ in.

Failure Plate: PL-20

COMMENTS

- * PL-20 yielded at 15500 lbs. and 0.014 in. of deformation.
- * PL-20 started bulging at 0.044 in of deformation.
- * The connection maintained its strength after yielding point.

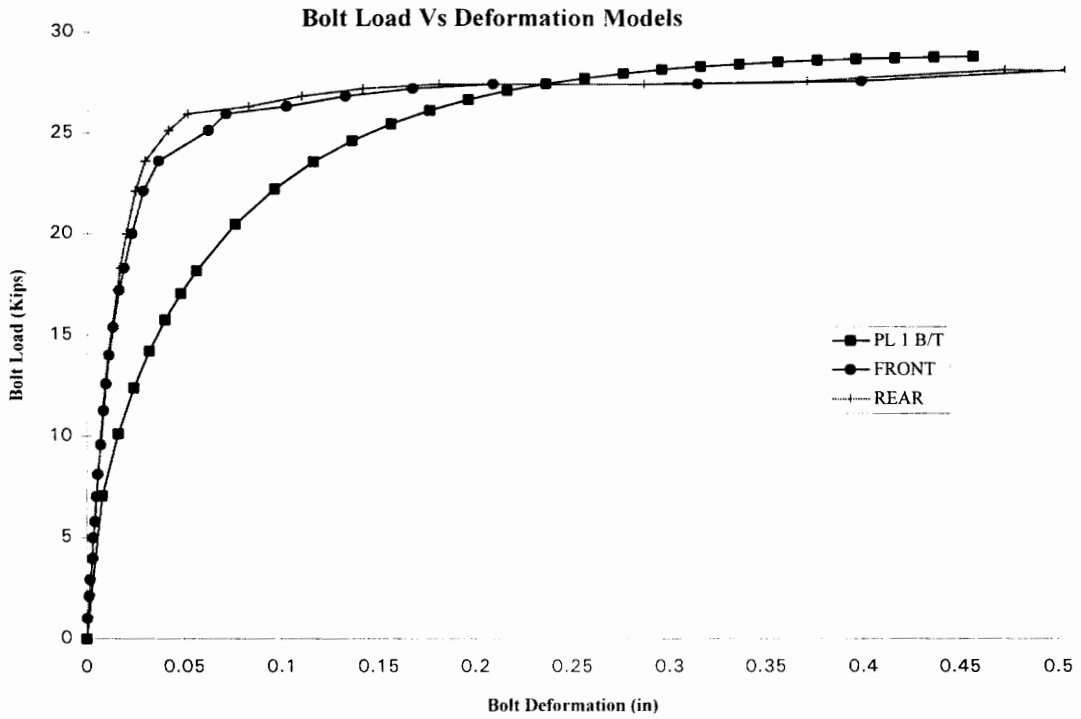

Figure C-34

Plate				Bolt	
	tp	Fu	B/T	Bolt Dia.	A325
Plate 1	0.25	66.2	28.96	Fv	72
Plate 2	0.75	70.4	91.74	Bolt Shear	43.29

Richard Coefficients

$K = 0$ $K_p = 0$ $R_o = 0$
 $K_1 = 0$ $n = 0$

Data Point	Volts	Load	F1	F2	F3	F4	R1	R2	R3	R4	AVG(F)	AVG(R)
1	0.07	1.03	0.000	0.000	-0.001	-0.001	-0.001	-0.001	0.001	0.000	0.000	0.000
2	0.14	2.12	0.000	0.000	-0.003	-0.002	-0.003	-0.002	0.001	0.000	0.001	0.001
3	0.20	2.93	0.001	0.000	-0.004	-0.004	-0.004	-0.004	0.001	-0.001	0.002	0.002
4	0.26	3.96	0.001	0.000	-0.006	-0.007	-0.005	-0.006	0.001	-0.001	0.003	0.003
5	0.33	4.98	0.001	0.000	-0.007	-0.008	-0.007	-0.008	0.002	-0.001	0.003	0.003
6	0.39	5.79	0.001	-0.001	-0.008	-0.010	-0.007	-0.010	0.002	-0.001	0.004	0.004
7	0.47	7.03	0.002	-0.001	-0.009	-0.012	-0.009	-0.012	0.002	-0.001	0.005	0.005
8	0.54	8.13	0.003	-0.001	-0.012	-0.013	-0.010	-0.014	0.003	-0.003	0.006	0.006
9	0.64	9.59	0.003	-0.001	-0.014	-0.017	-0.011	-0.017	0.004	-0.004	0.007	0.007
10	0.75	11.28	0.003	-0.002	-0.016	-0.020	-0.013	-0.020	0.005	-0.004	0.009	0.008
11	0.84	12.59	0.003	-0.002	-0.018	-0.022	-0.013	-0.023	0.006	-0.006	0.010	0.009
12	0.93	13.99	0.004	-0.004	-0.019	-0.026	-0.013	-0.029	0.008	-0.009	0.011	0.011
13	1.03	15.39	0.004	-0.006	-0.021	-0.030	-0.014	-0.035	0.010	-0.012	0.013	0.013
14	1.15	17.21	0.004	-0.009	-0.024	-0.037	-0.014	-0.043	0.013	-0.018	0.016	0.015
15	1.22	18.31	0.004	-0.012	-0.026	-0.042	-0.014	-0.048	0.015	-0.021	0.019	0.017
16	1.33	20.00	0.004	-0.017	-0.029	-0.050	-0.013	-0.058	0.019	-0.028	0.023	0.020
17	1.48	22.13	0.005	-0.025	-0.033	-0.062	-0.015	-0.071	0.023	-0.036	0.029	0.024
18	1.57	23.59	0.004	-0.036	-0.039	-0.075	-0.016	-0.083	0.025	-0.044	0.037	0.030
19	1.68	25.13	-0.015	-0.063	-0.062	-0.108	-0.025	-0.105	0.024	-0.060	0.062	0.041
20	1.73	25.94	-0.022	-0.072	-0.071	-0.119	-0.034	-0.118	0.018	-0.070	0.071	0.051
21	1.75	26.30	-0.051	-0.104	-0.101	-0.153	-0.066	-0.153	-0.011	-0.100	0.102	0.083
22	1.79	26.82	-0.080	-0.133	-0.131	-0.185	-0.093	-0.183	-0.037	-0.127	0.132	0.110
23	1.81	27.18	-0.111	-0.168	-0.167	-0.222	-0.126	-0.217	-0.065	-0.156	0.167	0.141
24	1.83	27.40	-0.152	-0.209	-0.208	-0.265	-0.167	-0.259	-0.103	-0.195	0.209	0.181
25	1.83	27.40	-0.254	-0.315	-0.317	-0.373	-0.273	-0.368	-0.207	-0.300	0.315	0.287
26	1.84	27.55	-0.338	-0.398	-0.401	-0.459	-0.359	-0.453	-0.290	-0.382	0.399	0.371
27	1.88	28.13	-0.442	-0.504	-0.508	-0.566	-0.461	-0.556	-0.391	-0.480	0.505	0.472
28	1.87	27.99	-0.538	-0.600	-0.606	-0.666	-0.555	-0.652	-0.480	-0.572	0.603	0.564

Table C-34

TENSION TESTS ON BOLTED CONNECTIONS

SUMMARY SHEET

Test No: 35

Date: March 26, 1995

Test Designation: 1/4x1x7/8

Recorder: Burak Karsu

GEOMETRIC AND MATERIAL PROPERTIES

BOLT

Type:A325

Diameter $d_b=0.875$ in.

Length $L_b= 2.75$ in.

Shear Str. $F_v=72$ ksi

Edge Dist. $e=1.625$ in.

Fully Pretensioned--Yes

Bolt Hole Fabr.--Drilled

Bolt Hole Type--Standard

Threads in Shear Plane--X

PLATES

No	Designation	Length (in.)	Width (in.)	Thickness (in.)	Hole Dia. (in.)	Fy (ksi)	Fu (ksi)
Plate 1	PL-20	24.0	4.0	0.25	15/16	46.1	66.2
Plate 2	PL-32	24.0	4.0	1.0	15/16	41.5	67.6

TEST RESULTS

Failure Type: Bearing /Tear Out

Failure Load: 28870 lbs.

Max Deflection $\Delta_{max}=0.77$ in.

Failure Plate: PL-20

COMMENTS

* PL-20 yielded at 21500 lbs.

* PL-20 bulged at 27500 lbs.

* Splitting occurred at 0.75 in.

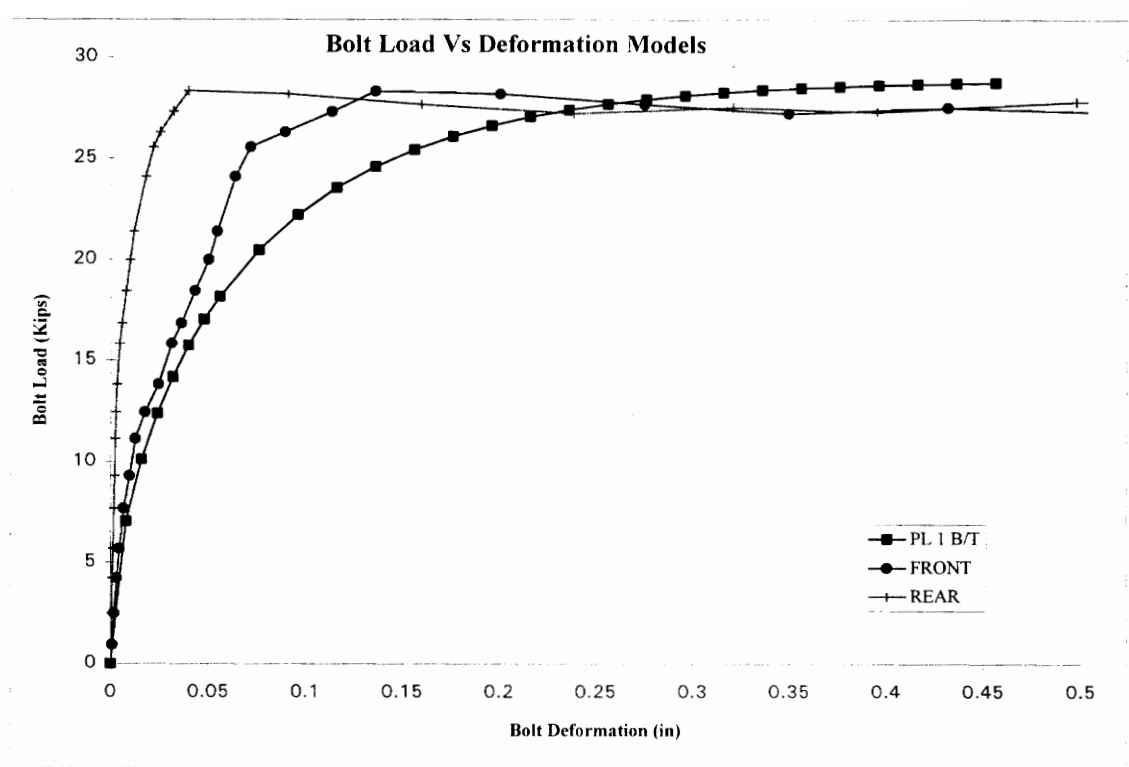

Figure C-35

Plate	tp	Fu	B/T	Bolt	A325
Plate 1	0.25	66.2	28.96	Bolt Dia.	0.875
Plate 2	1	67.6	118.30	Fv	72
				Bolt Shear	43.29

Richard Coefficients

K= 0 Kp= 0 Ro= 0
 K1= 0 n= 0

Data Point	Volts	Load	F1	F2	F3	F4	R1	R2	R3	R4	AVG(F0)	AVG(R)
1	0.06	0.95	0.000	0.000	-0.002	-0.002	0.000	0.000	-0.001	0.000	0.001	0.000
2	0.17	2.49	0.000	0.001	-0.003	-0.005	0.000	-0.001	-0.001	-0.001	0.002	0.001
3	0.28	4.25	0.000	0.001	-0.006	-0.008	0.000	-0.001	-0.002	-0.001	0.003	0.001
4	0.38	5.71	0.000	0.001	-0.010	-0.010	0.000	-0.002	-0.002	-0.001	0.005	0.001
5	0.51	7.69	0.000	0.003	-0.015	-0.015	0.000	-0.003	-0.002	-0.002	0.007	0.002
6	0.62	9.30	-0.001	0.004	-0.023	-0.020	0.000	-0.002	-0.003	-0.003	0.010	0.002
7	0.74	11.14	-0.002	0.007	-0.031	-0.025	0.000	-0.002	-0.003	-0.004	0.013	0.002
8	0.83	12.46	-0.005	0.004	-0.039	-0.032	0.000	-0.002	-0.004	-0.005	0.018	0.003
9	0.92	13.84	-0.010	-0.002	-0.045	-0.041	0.000	-0.004	-0.004	-0.006	0.025	0.003
10	1.06	15.83	-0.012	-0.009	-0.052	-0.052	0.000	-0.007	-0.004	-0.008	0.031	0.005
11	1.12	16.85	-0.015	-0.015	-0.055	-0.061	0.000	-0.010	-0.004	-0.010	0.036	0.006
12	1.23	18.47	-0.017	-0.025	-0.059	-0.072	0.000	-0.015	-0.004	-0.013	0.043	0.008
13	1.33	20.00	-0.018	-0.034	-0.064	-0.084	0.000	-0.018	-0.006	-0.015	0.050	0.010
14	1.43	21.40	-0.019	-0.042	-0.065	-0.092	0.000	-0.023	-0.007	-0.017	0.055	0.012
15	1.61	24.11	-0.021	-0.056	-0.070	-0.108	0.000	-0.035	-0.013	-0.023	0.064	0.018
16	1.70	25.57	-0.024	-0.067	-0.075	-0.120	0.000	-0.042	-0.019	-0.026	0.072	0.022
17	1.75	26.30	-0.039	-0.086	-0.092	-0.141	0.000	-0.046	-0.024	-0.030	0.089	0.025
18	1.82	27.33	-0.061	-0.111	-0.116	-0.166	0.000	-0.058	-0.033	-0.036	0.113	0.032
19	1.89	28.35	-0.082	-0.133	-0.138	-0.190	0.000	-0.070	-0.043	-0.045	0.136	0.039
20	1.88	28.21	-0.142	-0.198	-0.204	-0.257	0.001	-0.139	-0.112	-0.112	0.200	0.091
21	1.85	27.69	-0.216	-0.272	-0.280	-0.333	-0.023	-0.239	-0.190	-0.187	0.275	0.160
22	1.82	27.26	-0.289	-0.346	-0.355	-0.408	-0.099	-0.325	-0.266	-0.263	0.350	0.238
23	1.84	27.55	-0.371	-0.428	-0.437	-0.491	-0.182	-0.408	-0.348	-0.345	0.432	0.321
24	1.82	27.33	-0.446	-0.504	-0.514	-0.566	-0.257	-0.484	-0.422	-0.417	0.507	0.395
25	1.86	27.84	-0.546	-0.603	-0.615	-0.668	-0.359	-0.592	-0.522	-0.516	0.608	0.497
26	1.85	27.77	-0.601	-0.658	-0.672	-0.723	-0.415	-0.648	-0.578	-0.572	0.664	0.554
27	1.86	27.84	-0.649	-0.708	-0.722	-0.773	-0.467	-0.698	-0.629	-0.622	0.713	0.604
28	1.92	28.87	-0.703	-0.766	-0.780	-0.830	-0.527	-0.760	-0.688	-0.682	0.770	0.664

Table C-35

TENSION TESTS ON BOLTED CONNECTIONS

SUMMARY SHEET

Test No: 36

Date: March 26, 1995

Test Designation: 3/8x3/8x7/8

Recorder: Burak Karsu

GEOMETRIC AND MATERIAL PROPERTIES

BOLT

Type:A325

Diameter $d_b=0.875$ in.

Length $L_b= 2.25$ in.

Shear Str. $F_v=72$ ksi

Edge Dist. $e=1.625$ in.

Fully Pretensioned--Yes

Bolt Hole Fabr.--Drilled

Bolt Hole Type--Standard

Threads in Shear Plane--X

PLATES

No	Designation	Length (in.)	Width (in.)	Thickness (in.)	Hole Dia. (in.)	Fy (ksi)	Fu (ksi)
Plate 1	PL-22	24.0	4.0	0.375	15/16	43.4	63.8
Plate 2	PL-22	24.0	4.0	0.375	15/16	43.4	63.8

TEST RESULTS

Failure Type: Bearing / Tear Out

Failure Load: 42400 lbs/plate

Max Deflection $\Delta_{max}=1.45$ in.

Failure Plate: PL-22

COMMENTS

*PL-22 yielded at 23000 lbs and 0.04 in. of deformation.

*At 30000 lbs, bulging started on PL-22

*At 1.4 in. of deformation splitting was observed at the edge of the plate.

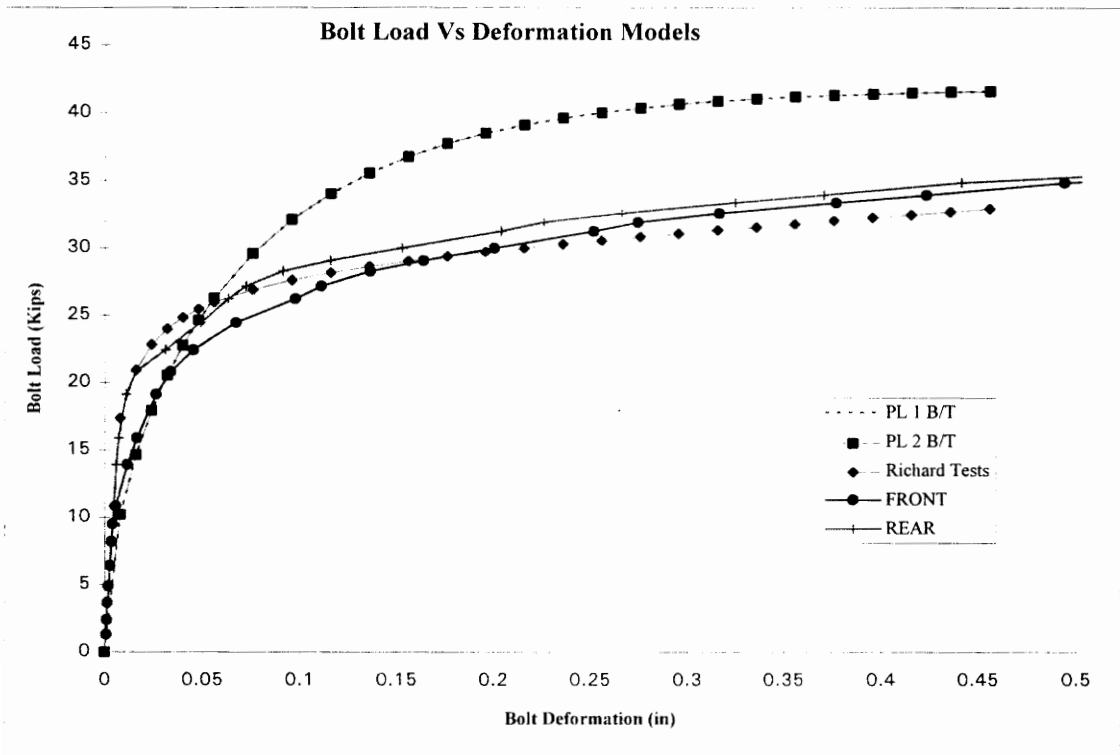

Figure C-36

Plate				Bolt	
	tp	Fu	B/T	Bolt Dia.	A325
Plate 1	0.375	63.8	41.87	Fv	72
Plate 2	0.375	63.8	41.87	Bolt Shear	43.29

Richard Coefficients

K= 10875 Kp= 9 Ro= 30
 K1= 10866 n= 0.7

Data Point	Volts	Load	F1	F2	F3	F4	R1	R2	R3	R4	AVG(F)	AVG(R)
1	0.09	1.32	-0.001	-0.001	-0.001	-0.001	-0.001	-0.001	0.000	-0.001	0.001	0.000
2	0.16	2.41	-0.001	-0.001	-0.002	-0.001	-0.001	-0.001	-0.001	-0.001	0.001	0.001
3	0.24	3.66	-0.002	-0.001	-0.002	-0.001	-0.002	-0.002	-0.001	-0.001	0.002	0.002
4	0.33	4.91	-0.002	-0.001	-0.004	-0.001	-0.003	-0.003	-0.001	-0.002	0.002	0.002
5	0.43	6.45	-0.004	-0.001	-0.006	-0.001	-0.004	-0.003	-0.002	-0.002	0.003	0.003
6	0.55	8.20	-0.005	-0.001	-0.007	-0.002	-0.004	-0.004	-0.002	-0.002	0.004	0.003
7	0.63	9.52	-0.006	-0.001	-0.008	-0.002	-0.006	-0.005	-0.002	-0.003	0.004	0.004
8	0.72	10.84	-0.009	-0.001	-0.012	-0.001	-0.006	-0.006	-0.002	-0.004	0.006	0.005
9	0.93	13.92	-0.021	0.000	-0.024	-0.001	-0.006	-0.009	-0.002	-0.007	0.012	0.006
10	1.06	15.89	-0.030	-0.001	-0.033	-0.002	-0.006	-0.012	-0.002	-0.009	0.017	0.007
11	1.28	19.13	-0.043	-0.007	-0.046	-0.009	-0.006	-0.020	-0.001	-0.017	0.026	0.011
12	1.39	20.81	-0.053	-0.013	-0.056	-0.013	-0.009	-0.026	-0.004	-0.024	0.034	0.016
13	1.49	22.42	-0.067	-0.021	-0.071	-0.022	-0.025	-0.041	-0.020	-0.039	0.045	0.031
14	1.63	24.44	-0.093	-0.040	-0.096	-0.040	-0.043	-0.059	-0.039	-0.056	0.067	0.049
15	1.75	26.23	-0.125	-0.070	-0.128	-0.068	-0.057	-0.074	-0.052	-0.070	0.098	0.063
16	1.81	27.18	-0.139	-0.083	-0.142	-0.081	-0.065	-0.084	-0.061	-0.079	0.111	0.072
17	1.89	28.28	-0.166	-0.108	-0.167	-0.105	-0.084	-0.105	-0.079	-0.098	0.136	0.091
18	1.94	29.09	-0.194	-0.134	-0.196	-0.132	-0.108	-0.130	-0.102	-0.124	0.164	0.116
19	2.00	30.04	-0.231	-0.171	-0.234	-0.168	-0.144	-0.168	-0.138	-0.161	0.201	0.153
20	2.09	31.28	-0.284	-0.222	-0.284	-0.218	-0.196	-0.220	-0.188	-0.213	0.252	0.204
21	2.13	31.94	-0.308	-0.244	-0.308	-0.240	-0.217	-0.242	-0.209	-0.236	0.275	0.226
22	2.17	32.60	-0.349	-0.285	-0.351	-0.283	-0.256	-0.285	-0.249	-0.276	0.317	0.266
23	2.23	33.41	-0.410	-0.345	-0.413	-0.342	-0.315	-0.345	-0.307	-0.334	0.377	0.325
24	2.27	33.99	-0.457	-0.391	-0.459	-0.388	-0.361	-0.391	-0.352	-0.379	0.424	0.371
25	2.33	34.95	-0.528	-0.461	-0.531	-0.458	-0.432	-0.463	-0.423	-0.450	0.494	0.442
26	2.37	35.53	-0.607	-0.539	-0.609	-0.536	-0.509	-0.542	-0.500	-0.528	0.573	0.520
27	2.42	36.26	-0.656	-0.585	-0.657	-0.584	-0.557	-0.589	-0.547	-0.576	0.621	0.567
28	2.46	36.85	-0.733	-0.664	-0.737	-0.663	-0.638	-0.669	-0.629	-0.654	0.699	0.648
29	2.51	37.58	-0.806	-0.736	-0.811	-0.735	-0.711	-0.745	-0.701	-0.727	0.772	0.721
30	2.53	38.02	-0.885	-0.813	-0.890	-0.815	-0.790	-0.824	-0.781	-0.809	0.851	0.801
31	2.57	38.54	-0.949	-0.878	-0.957	-0.881	-0.855	-0.890	-0.845	-0.872	0.916	0.865
32	2.60	39.02	-1.040	-0.969	-1.049	-0.973	-0.944	-0.980	-0.937	-0.963	1.008	0.956
33	2.64	39.56	-1.139	-1.065	-1.147	-1.070	-1.043	-1.078	-1.035	-1.062	1.105	1.055
34	2.66	39.94	-1.228	-1.156	-1.237	-1.161	-1.134	-1.169	-1.126	-1.153	1.195	1.146
35	2.82	42.35	-1.359	-1.285	-1.368	-1.290	-1.264	-1.302	-1.258	-1.282	1.326	1.276
36	2.74	41.03	-1.522	-1.452	-1.531	-1.455	-1.404	-1.444	-1.371	-1.421	1.490	1.410

Table C-36

TENSION TESTS ON BOLTED CONNECTIONS

SUMMARY SHEET

Test No: 37

Date: March 27, 1995

Test Designation: 3/8x1/2x7/8

Recorder: Burak Karsu

GEOMETRIC AND MATERIAL PROPERTIES

BOLT

Type: A325

Diameter $d_b=0.875$ in.

Length $L_b=2.25$ in.

Shear Str. $F_v=72$ ksi

Edge Dist. $e=1.625$ in.

Fully Pretensioned--Yes

Bolt Hole Fabr.--Drilled

Bolt Hole Type--Standard

Threads in Shear Plane--X

PLATES

No	Designation	Length (in.)	Width (in.)	Thickness (in.)	Hole Dia. (in.)	Fy (ksi)	Fu (ksi)
Plate 1	PL-22	24.0	4.0	0.375	15/16	43.4	63.8
Plate 2	PL-35	24.0	4.0	0.500	15/16	44.8	69.0

TEST RESULTS

Failure Type: Bearing/ Tear Out

Failure Load: 41100 lbs/plate

Max Deflection $\Delta_{max}=0.92$ in.

Failure Plate: PL-22

COMMENTS

* Yielding on PL-22 started at 27000 lbs with a deformation of 0.05 in.

* PL-35 yielded at 33500 lbs.

* The connection gained strength.

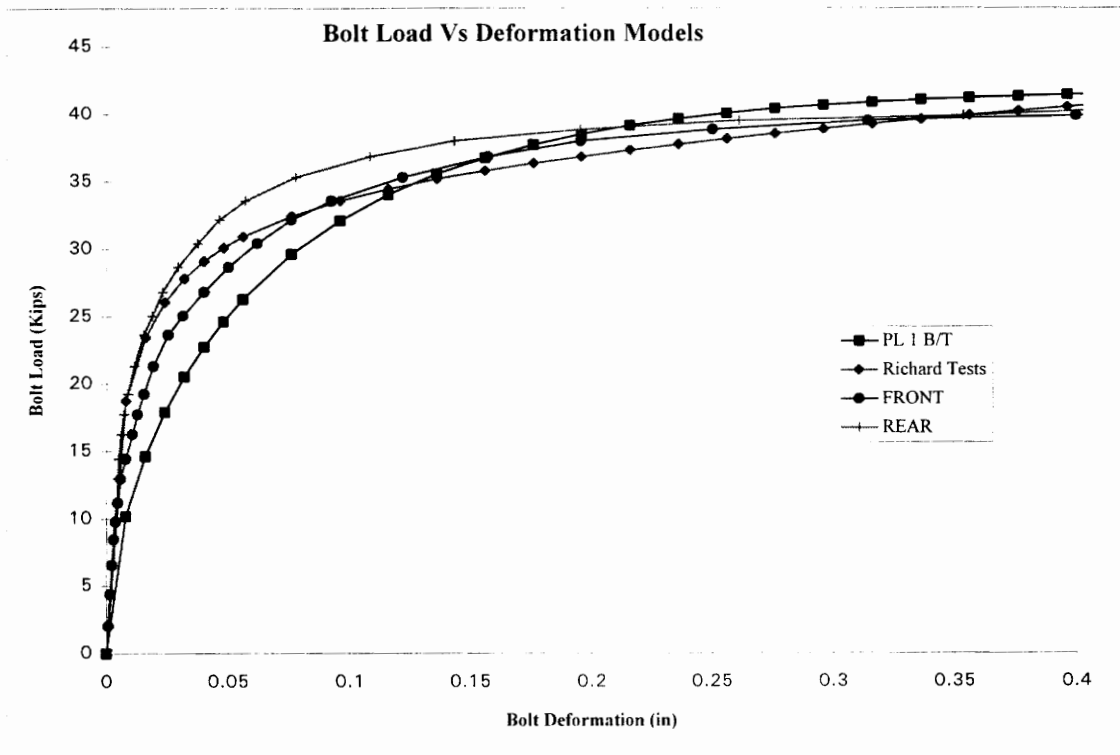

Figure C-37

Plate				Bolt	A325
	tp	Fu	B/T	Bolt Dia.	0.875
Plate 1	0.375	63.8	41.87	Fv	72
Plate 2	0.5	69	60.38	Bolt Shear	43.29

Richard Coefficients

K= 12400	Kp= 10	Ro= 40
K1= 12390	n= 0.6	

Data Point	Volts	Load	F1	F2	F3	F4	R1	R2	R3	R4	AVG(F)	AVG(R)
1	0.14	2.05	-0.001	0.000	-0.001	-0.001	-0.001	0.000	-0.001	-0.001	0.001	0.001
2	0.29	4.39	-0.002	-0.001	-0.002	-0.002	-0.002	-0.001	-0.001	-0.001	0.002	0.001
3	0.44	6.59	-0.002	-0.002	-0.003	-0.002	-0.004	-0.002	-0.002	-0.001	0.002	0.002
4	0.57	8.50	-0.003	-0.002	-0.004	-0.004	-0.005	-0.003	-0.002	-0.002	0.003	0.003
5	0.65	9.81	-0.004	-0.002	-0.005	-0.004	-0.005	-0.004	-0.002	-0.002	0.004	0.004
6	0.75	11.21	-0.004	-0.004	-0.006	-0.006	-0.007	-0.004	-0.004	-0.002	0.005	0.004
7	0.86	12.96	-0.003	-0.006	-0.006	-0.009	-0.007	-0.005	-0.004	-0.002	0.006	0.005
8	0.96	14.43	-0.003	-0.010	-0.007	-0.012	-0.009	-0.005	-0.005	-0.002	0.008	0.005
9	1.08	16.26	-0.003	-0.015	-0.007	-0.018	-0.011	-0.006	-0.006	-0.002	0.011	0.006
10	1.18	17.72	-0.004	-0.018	-0.008	-0.021	-0.013	-0.006	-0.008	-0.002	0.013	0.007
11	1.28	19.26	-0.004	-0.022	-0.010	-0.026	-0.016	-0.006	-0.010	-0.002	0.015	0.009
12	1.42	21.32	-0.006	-0.028	-0.012	-0.032	-0.021	-0.007	-0.015	-0.002	0.019	0.011
13	1.58	23.67	-0.008	-0.035	-0.017	-0.042	-0.029	-0.009	-0.020	-0.003	0.025	0.015
14	1.67	25.06	-0.012	-0.041	-0.023	-0.050	-0.035	-0.011	-0.025	-0.004	0.031	0.019
15	1.79	26.82	-0.018	-0.049	-0.032	-0.061	-0.043	-0.014	-0.031	-0.005	0.040	0.023
16	1.91	28.65	-0.026	-0.058	-0.043	-0.073	-0.053	-0.019	-0.038	-0.008	0.050	0.029
17	2.03	30.40	-0.036	-0.070	-0.055	-0.087	-0.065	-0.027	-0.046	-0.012	0.062	0.038
18	2.14	32.16	-0.048	-0.083	-0.070	-0.102	-0.077	-0.035	-0.055	-0.018	0.076	0.046
19	2.24	33.55	-0.064	-0.098	-0.087	-0.120	-0.091	-0.045	-0.066	-0.026	0.093	0.057
20	2.35	35.31	-0.091	-0.127	-0.117	-0.152	-0.116	-0.065	-0.087	-0.043	0.122	0.078
21	2.46	36.86	-0.124	-0.161	-0.155	-0.190	-0.150	-0.095	-0.118	-0.070	0.157	0.108
22	2.53	38.02	-0.160	-0.198	-0.195	-0.231	-0.188	-0.130	-0.153	-0.102	0.196	0.143
23	2.59	38.85	-0.213	-0.251	-0.251	-0.286	-0.244	-0.182	-0.205	-0.151	0.250	0.195
24	2.63	39.50	-0.275	-0.314	-0.316	-0.352	-0.312	-0.248	-0.270	-0.216	0.314	0.261
25	2.66	39.86	-0.358	-0.398	-0.403	-0.439	-0.407	-0.341	-0.361	-0.305	0.400	0.353
26	2.68	40.23	-0.407	-0.451	-0.453	-0.491	-0.461	-0.392	-0.415	-0.353	0.451	0.405
27	2.70	40.52	-0.469	-0.513	-0.518	-0.555	-0.529	-0.458	-0.481	-0.419	0.514	0.472
28	2.70	40.45	-0.509	-0.556	-0.561	-0.597	-0.572	-0.501	-0.524	-0.461	0.556	0.515
29	2.74	41.03	-0.615	-0.659	-0.669	-0.705	-0.686	-0.613	-0.636	-0.575	0.662	0.627
30	2.79	41.91	-0.670	-0.716	-0.725	-0.761	-0.745	-0.670	-0.692	-0.628	0.718	0.683
31	2.86	42.86	-0.815	-0.864	-0.874	-0.911	-0.897	-0.818	-0.840	-0.778	0.866	0.833
32	2.81	42.13	-0.865	-0.912	-0.925	-0.959	-0.985	-0.906	-0.932	-0.866	0.915	0.922

Table C-37

TENSION TESTS ON BOLTED CONNECTIONS

SUMMARY SHEET

Test No: 38

Date: March 27, 1995

Test Designation: 3/8x3/4x7/8

Recorder: Burak Karsu

GEOMETRIC AND MATERIAL PROPERTIES

BOLT

Type: A325

Diameter $d_b=0.875$ in.

Length $L_b=2.5$ in.

Shear Str. $F_v=72$ ksi

Edge Dist. $e=1.625$ in.

Fully Pretensioned--Yes

Bolt Hole Fabr.--Drilled

Bolt Hole Type--Standard

Threads in Shear Plane--X

PLATES

No	Designation	Length (in.)	Width (in.)	Thickness (in.)	Hole Dia. (in.)	Fy (ksi)	Fu (ksi)
Plate 1	PL-22	24.0	4.0	0.375	15/16	43.4	63.8
Plate 2	PL-29	24.0	4.0	0.75	15/16	44.6	69.9

TEST RESULTS

Failure Type: Bearing / Tear Out

Failure Load: 41000 lbs/plate

Max Deflection $\Delta_{max}=1.0$ in.

Failure Plate: PL-22

COMMENTS

- * PL-22 yielded at 23000 lbs with a deformation of 0.025 in.
- * PL-22 bulged at 33500 lbs, 0.12 in. of deformation.
- * Splitting started at 0.95 in.
- * Connection gained strength.

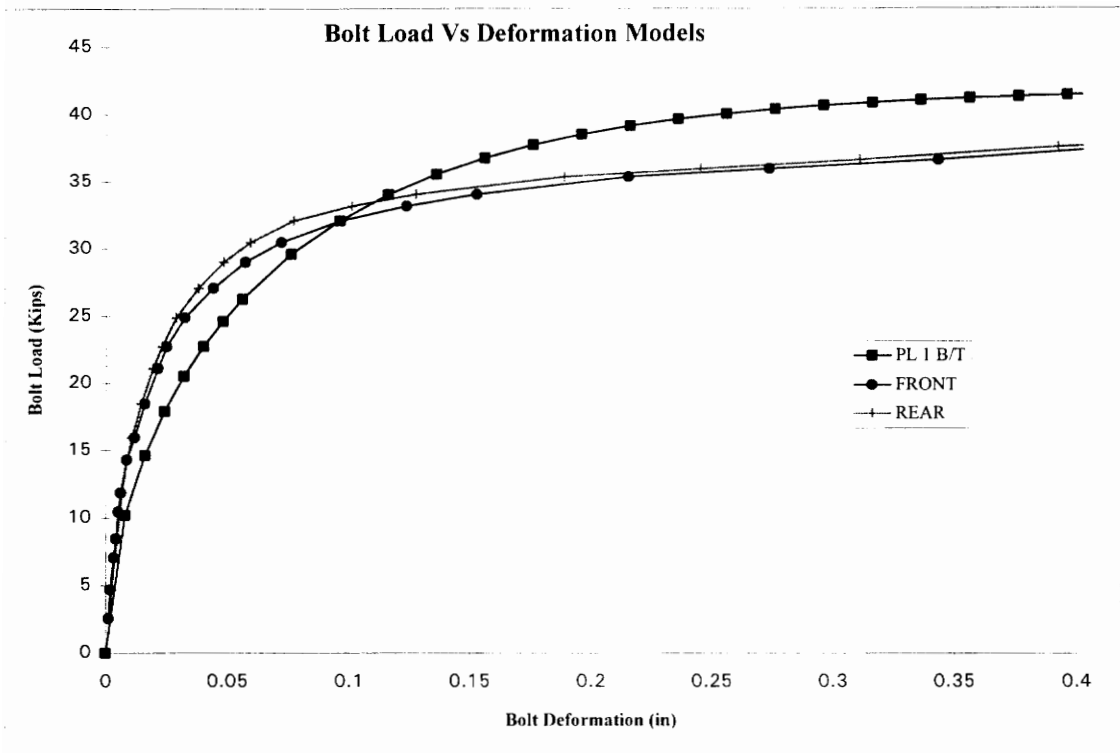

Figure C-38

Plate		Bolt	
	tp	Fu	B/T
Plate 1	0.375	63.8	41.87
Plate 2	0.75	70.4	91.74
		Fv	72
		Bolt Shear	43.29

Richard Coefficients

K= 0 Kp= 0 Ro= 0
 K1= 0 n= 0

Data Point	Volts	Load	F1	F2	F3	F4	R1	R2	R3	R4	AVG(F)	AVG(R)
1	0.17	2.56	-0.001	0.000	-0.002	-0.002	-0.003	-0.002	-0.001	0.001	0.001	0.001
2	0.31	4.69	-0.001	0.000	-0.003	-0.004	-0.006	-0.004	-0.001	0.001	0.002	0.002
3	0.47	7.10	-0.001	-0.001	-0.006	-0.006	-0.009	-0.007	-0.001	0.001	0.003	0.004
4	0.57	8.50	-0.001	-0.002	-0.007	-0.008	-0.010	-0.009	-0.001	0.001	0.004	0.005
5	0.70	10.47	-0.001	-0.002	-0.007	-0.010	-0.012	-0.011	-0.001	0.001	0.005	0.006
6	0.79	11.87	-0.001	-0.004	-0.009	-0.012	-0.013	-0.013	-0.001	0.000	0.006	0.007
7	0.95	14.28	0.000	-0.007	-0.010	-0.017	-0.016	-0.017	-0.001	-0.001	0.009	0.009
8	1.07	15.98	-0.001	-0.010	-0.013	-0.023	-0.018	-0.020	-0.002	-0.002	0.012	0.011
9	1.23	18.46	-0.002	-0.014	-0.017	-0.030	-0.024	-0.024	-0.005	-0.005	0.016	0.015
10	1.41	21.10	-0.004	-0.020	-0.022	-0.039	-0.031	-0.029	-0.009	-0.007	0.021	0.019
11	1.51	22.71	-0.006	-0.024	-0.024	-0.045	-0.037	-0.034	-0.013	-0.009	0.025	0.023
12	1.66	24.91	-0.008	-0.034	-0.031	-0.057	-0.045	-0.039	-0.019	-0.012	0.032	0.029
13	1.81	27.11	-0.014	-0.046	-0.041	-0.075	-0.059	-0.048	-0.028	-0.016	0.044	0.038
14	1.93	29.01	-0.022	-0.060	-0.054	-0.093	-0.074	-0.059	-0.039	-0.022	0.057	0.048
15	2.03	30.48	-0.032	-0.077	-0.066	-0.113	-0.090	-0.069	-0.050	-0.029	0.072	0.059
16	2.14	32.09	-0.053	-0.103	-0.089	-0.141	-0.111	-0.087	-0.068	-0.042	0.096	0.077
17	2.21	33.19	-0.078	-0.131	-0.115	-0.171	-0.139	-0.109	-0.092	-0.063	0.124	0.101
18	2.27	34.07	-0.105	-0.161	-0.143	-0.202	-0.168	-0.135	-0.120	-0.087	0.153	0.127
19	2.36	35.39	-0.163	-0.224	-0.206	-0.269	-0.233	-0.198	-0.181	-0.144	0.215	0.189
20	2.40	35.97	-0.218	-0.282	-0.264	-0.330	-0.291	-0.255	-0.237	-0.197	0.274	0.245
21	2.44	36.63	-0.286	-0.351	-0.335	-0.402	-0.359	-0.322	-0.302	-0.260	0.343	0.311
22	2.51	37.58	-0.362	-0.429	-0.413	-0.484	-0.442	-0.405	-0.382	-0.340	0.422	0.392
23	2.55	38.25	-0.457	-0.527	-0.511	-0.585	-0.548	-0.511	-0.486	-0.442	0.520	0.497
24	2.61	39.13	-0.563	-0.634	-0.620	-0.699	-0.660	-0.623	-0.596	-0.549	0.629	0.607
25	2.66	39.86	-0.657	-0.730	-0.716	-0.797	-0.759	-0.722	-0.692	-0.643	0.725	0.704
26	2.71	40.67	-0.756	-0.833	-0.818	-0.903	-0.865	-0.829	-0.796	-0.749	0.827	0.810
27	2.74	41.11	-0.820	-0.896	-0.881	-0.967	-0.932	-0.896	-0.863	-0.812	0.891	0.876
28	2.60	38.98	-0.975	-1.057	-1.031	-1.121	-1.038	-1.005	-0.965	-0.918	1.046	0.982

Table C-38

TENSION TESTS ON BOLTED CONNECTIONS

SUMMARY SHEET

Test No: 40

Date: March 28, 1995

Test Designation: 1/2x1/2x7/8

Recorder: Burak Karsu

GEOMETRIC AND MATERIAL PROPERTIES

BOLT

Type:A325

Diameter $d_b=0.875$ in.

Length $L_b= 2.5$ in.

Shear Str. $F_v=72$ ksi

Edge Dist. $e=1.75$ in.

Fully Pretensioned--Yes

Bolt Hole Fabr.--Drilled

Bolt Hole Type--Standard

Threads in Shear Plane--X

PLATES

No	Designation	Length (in.)	Width (in.)	Thickness (in.)	Hole Dia. (in.)	Fy (ksi)	Fu (ksi)
Plate 1	PL-34	24.0	4.0	0.5	15/16	51.8	73.8
Plate 2	PL-34	24.0	4.0	0.5	15/16	51.8	73.8

TEST RESULTS

Failure Type: Bolt Shear

Failure Load: 49000 lbs/bolt

Max Deflection $\Delta_{max}=0.36$ in.

Failure Plate: PL-34

COMMENTS

* PL-34 yielded at 30500 lbs, 0.04 in of deformation.

* Bulging started on PL-34 at 49000 lbs.

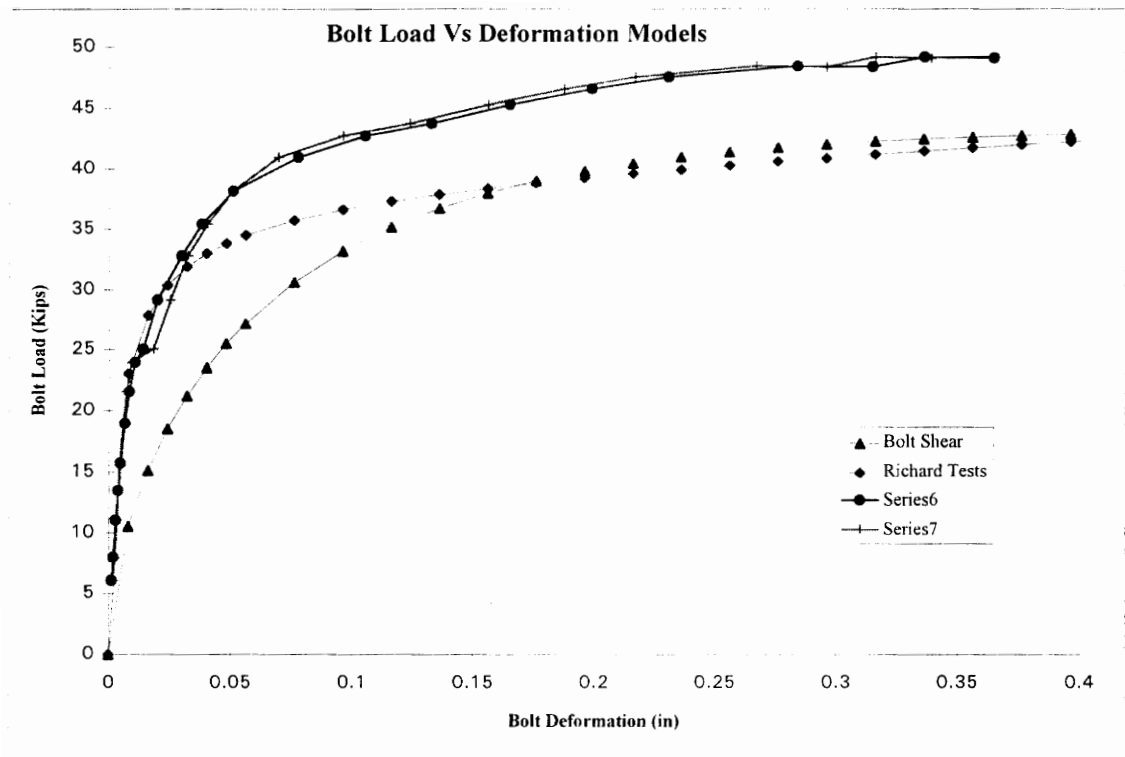

Figure C-40

Plate				Bolt	A325
	tp	Fu	B/T	Bolt Dia.	0.875
Plate 1	0.5	73.8	64.58	Fv	72
Plate 2	0.5	73.8	64.58	Bolt Shear	43.29

Richard Coefficients

K= 14500 Kp= 10 Ro= 40
 K1= 14490 n= 0.7

Data Point	Volts	Load	F1	F2	F3	F4	R1	R2	R3	R4	AVG(F)	AVG(R)
1	0.41	6.08	-0.001	-0.001	-0.001	-0.002	-0.002	-0.002	-0.002	0.000	0.001	0.002
2	0.53	7.98	-0.002	-0.001	-0.002	-0.002	-0.002	-0.003	-0.002	-0.001	0.002	0.002
3	0.74	11.06	-0.004	-0.001	-0.004	-0.003	-0.003	-0.004	-0.004	-0.002	0.003	0.003
4	0.90	13.48	-0.005	-0.001	-0.006	-0.004	-0.003	-0.005	-0.004	-0.003	0.004	0.004
5	1.05	15.75	-0.007	-0.001	-0.008	-0.004	-0.004	-0.006	-0.004	-0.004	0.005	0.004
6	1.26	18.97	-0.010	-0.001	-0.012	-0.003	-0.005	-0.008	-0.004	-0.007	0.007	0.006
7	1.44	21.62	-0.014	0.000	-0.017	-0.002	-0.005	-0.011	-0.004	-0.009	0.008	0.007
8	1.60	23.96	-0.019	0.000	-0.021	-0.002	-0.005	-0.015	-0.004	-0.013	0.011	0.009
9	1.67	25.06	-0.025	0.001	-0.029	-0.002	-0.011	-0.027	-0.010	-0.025	0.014	0.018
10	1.94	29.16	-0.033	-0.002	-0.039	-0.006	-0.017	-0.035	-0.015	-0.034	0.020	0.025
11	2.19	32.82	-0.046	-0.009	-0.052	-0.012	-0.024	-0.044	-0.021	-0.041	0.030	0.032
12	2.36	35.46	-0.056	-0.015	-0.062	-0.018	-0.031	-0.053	-0.028	-0.050	0.038	0.040
13	2.55	38.18	-0.070	-0.026	-0.078	-0.029	-0.041	-0.064	-0.038	-0.060	0.051	0.051
14	2.73	40.96	-0.099	-0.051	-0.107	-0.053	-0.059	-0.084	-0.056	-0.080	0.078	0.069
15	2.85	42.72	-0.128	-0.078	-0.136	-0.080	-0.085	-0.110	-0.083	-0.107	0.105	0.096
16	2.92	43.74	-0.157	-0.105	-0.164	-0.105	-0.112	-0.137	-0.111	-0.134	0.133	0.124
17	3.02	45.28	-0.191	-0.136	-0.197	-0.137	-0.144	-0.170	-0.144	-0.167	0.165	0.156
18	3.11	46.60	-0.226	-0.169	-0.231	-0.171	-0.175	-0.201	-0.175	-0.198	0.199	0.187
19	3.17	47.55	-0.258	-0.200	-0.263	-0.202	-0.205	-0.230	-0.204	-0.228	0.231	0.217
20	3.23	48.43	-0.312	-0.253	-0.317	-0.254	-0.255	-0.280	-0.255	-0.279	0.284	0.267
21	3.22	48.37	-0.343	-0.285	-0.348	-0.284	-0.283	-0.309	-0.284	-0.308	0.315	0.296
22	3.28	49.16	-0.364	-0.305	-0.370	-0.305	-0.304	-0.328	-0.304	-0.328	0.336	0.316
23	3.27	49.09	-0.393	-0.334	-0.398	-0.334	-0.327	-0.352	-0.327	-0.351	0.365	0.339

Table C-40

TENSION TESTS ON BOLTED CONNECTIONS

SUMMARY SHEET

Test No: 41

Date: April 3, 1995

Test Designation: 1/2x3/4x7/8

Recorder: Burak Karsu

GEOMETRIC AND MATERIAL PROPERTIES

BOLT

Type: A325 Diameter $d_b=0.875$ in. Length $L_b=2.75$ in.

Shear Str. $F_v=72$ ksi Edge Dist. $e=1.75$ in. Fully Pretensioned--Yes

Bolt Hole Fabr.--Drilled

Bolt Hole Type--Standard

Threads in Shear Plane--X

PLATES

No	Designation	Length (in.)	Width (in.)	Thickness (in.)	Hole Dia. (in.)	Fy (ksi)	Fu (ksi)
Plate 1	PL-34	24.0	4.0	0.5	15/16	51.8	73.8
Plate 2	PL-29	24.0	4.0	0.75	15/16	44.6	70.4

TEST RESULTS

Failure Type: Bolt Shear

Failure Load: 52300 lbs/bolt

Max Deflection $\Delta_{max}=0.5$ in.

Failure Plate: N/A

COMMENTS

* PL-34 yielded at 36000 lbs, 0.05 in. of deformation.

* PL-29 yielded at 41000 lbs, 0.1 in of deformation.

* PL-34 had a split at the edge of the plate at 0.45 in.

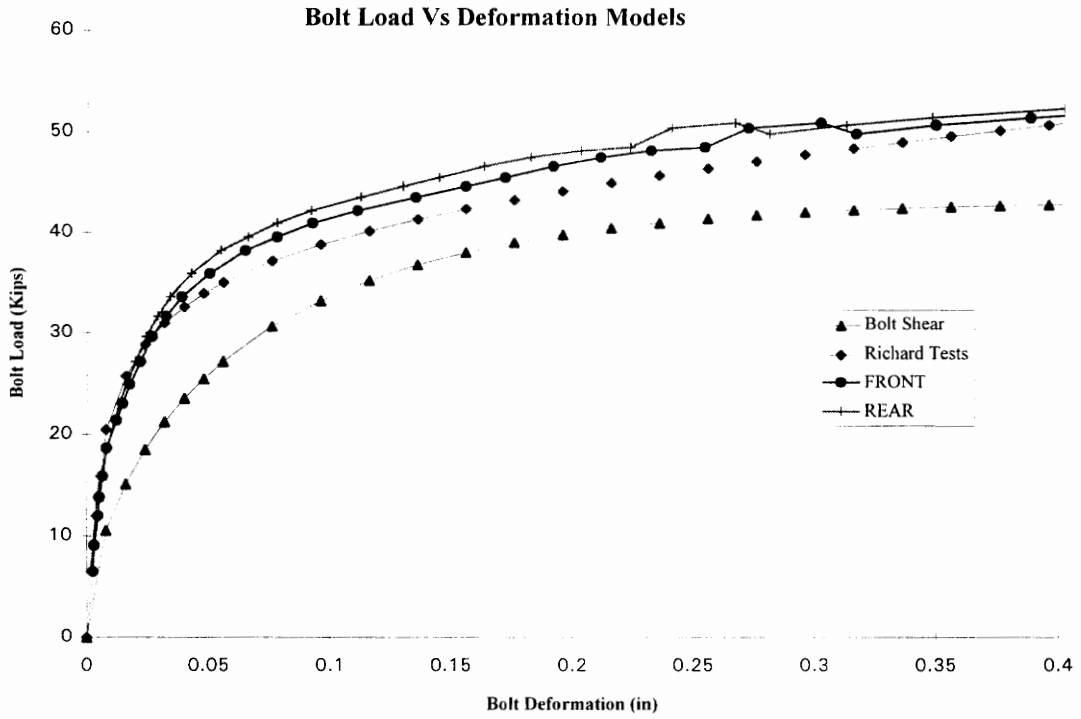

Figure C-41

Plate				Bolt	A325
	tp	Fu	B/T	Bolt Dia.	0.875
Plate 1	0.5	73.8	64.58	Fv	72
Plate 2	0.75	70.4	92.40	Bolt Shear	43.29

Richard Coefficients

K= 0 Kp= 0 Ro= 0
 K1= 0 n= 0

Data Point	Volts	Load	F1	F2	F3	F4	R1	R2	R3	R4	AVG(F)	AVG(R)
1	0.43	6.52	-0.002	-0.001	-0.004	-0.003	-0.003	-0.002	-0.001	-0.001	0.003	0.002
2	0.61	9.08	-0.002	-0.001	-0.005	-0.004	-0.004	-0.004	-0.002	-0.001	0.003	0.003
3	0.80	12.01	-0.002	-0.002	-0.007	-0.007	-0.005	-0.005	-0.002	-0.002	0.005	0.004
4	0.92	13.84	-0.002	-0.003	-0.008	-0.008	-0.006	-0.006	-0.002	-0.003	0.005	0.004
5	1.06	15.90	-0.002	-0.004	-0.009	-0.010	-0.007	-0.008	-0.004	-0.004	0.007	0.006
6	1.25	18.68	-0.002	-0.006	-0.010	-0.014	-0.010	-0.010	-0.007	-0.007	0.008	0.009
7	1.43	21.40	-0.003	-0.012	-0.013	-0.021	-0.014	-0.012	-0.010	-0.009	0.012	0.011
8	1.53	23.01	-0.004	-0.014	-0.016	-0.024	-0.017	-0.013	-0.013	-0.010	0.015	0.013
9	1.66	24.91	-0.005	-0.019	-0.017	-0.029	-0.021	-0.016	-0.017	-0.012	0.018	0.016
10	1.81	27.18	-0.006	-0.025	-0.020	-0.037	-0.027	-0.018	-0.022	-0.013	0.022	0.020
11	1.97	29.60	-0.007	-0.032	-0.023	-0.045	-0.033	-0.021	-0.028	-0.016	0.027	0.024
12	2.11	31.65	-0.009	-0.040	-0.026	-0.054	-0.040	-0.024	-0.034	-0.018	0.033	0.029
13	2.24	33.55	-0.012	-0.049	-0.031	-0.064	-0.046	-0.028	-0.041	-0.022	0.039	0.034
14	2.39	35.90	-0.019	-0.064	-0.039	-0.080	-0.057	-0.034	-0.051	-0.029	0.050	0.043
15	2.55	38.21	-0.029	-0.084	-0.049	-0.098	-0.070	-0.043	-0.067	-0.039	0.065	0.055
16	2.64	39.57	-0.040	-0.100	-0.059	-0.113	-0.082	-0.051	-0.081	-0.050	0.078	0.066
17	2.73	40.96	-0.053	-0.117	-0.071	-0.129	-0.093	-0.061	-0.096	-0.061	0.093	0.078
18	2.81	42.21	-0.072	-0.137	-0.087	-0.149	-0.109	-0.072	-0.113	-0.074	0.111	0.092
19	2.90	43.52	-0.094	-0.164	-0.109	-0.174	-0.130	-0.090	-0.136	-0.093	0.135	0.112
20	2.97	44.62	-0.114	-0.186	-0.128	-0.196	-0.148	-0.106	-0.155	-0.110	0.156	0.130
21	3.03	45.50	-0.129	-0.204	-0.144	-0.213	-0.163	-0.119	-0.172	-0.125	0.172	0.145
22	3.11	46.60	-0.149	-0.224	-0.162	-0.234	-0.183	-0.137	-0.192	-0.143	0.192	0.164
23	3.17	47.48	-0.168	-0.245	-0.180	-0.254	-0.202	-0.155	-0.213	-0.161	0.212	0.183
24	3.21	48.14	-0.187	-0.267	-0.200	-0.277	-0.224	-0.174	-0.234	-0.182	0.233	0.203
25	3.23	48.50	-0.207	-0.290	-0.223	-0.300	-0.244	-0.195	-0.255	-0.202	0.255	0.224
26	3.36	50.41	-0.224	-0.307	-0.241	-0.319	-0.263	-0.211	-0.273	-0.217	0.273	0.241
27	3.39	50.92	-0.254	-0.336	-0.270	-0.350	-0.291	-0.237	-0.300	-0.242	0.303	0.267
28	3.32	49.82	-0.268	-0.352	-0.284	-0.365	-0.305	-0.251	-0.314	-0.255	0.317	0.281
29	3.38	50.70	-0.300	-0.384	-0.316	-0.399	-0.337	-0.283	-0.347	-0.285	0.350	0.313
30	3.43	51.43	-0.337	-0.423	-0.355	-0.438	-0.373	-0.318	-0.383	-0.319	0.389	0.348
31	3.49	52.32	-0.393	-0.479	-0.412	-0.496	-0.428	-0.370	-0.440	-0.373	0.445	0.403

Table C-41

TENSION TESTS ON BOLTED CONNECTIONS

SUMMARY SHEET

Test No: 42

Date: April 2, 1995

Test Designation: 1/2x1x7/8

Recorder: Burak Karsu

GEOMETRIC AND MATERIAL PROPERTIES

BOLT

Type: A325

Diameter $d_b=0.875$ in.

Length $L_b=3.0$

Shear Str. $F_v=72$ ksi

Edge Dist. $e=1.75$ in.

Fully Pretensioned--Yes

Bolt Hole Fabr.--Drilled

Bolt Hole Type--Standard

Threads in Shear Plane--X

PLATES

No	Designation	Length (in.)	Width (in.)	Thickness (in.)	Hole Dia. (in.)	Fy (ksi)	Fu (ksi)
Plate 1	PL-33	24.0	4.0	0.5	15/16	53.3	74.0
Plate 2	PL-31	24.0	4.0	1.0	15/16	42.1	67.8

TEST RESULTS

Failure Type: Bolt Shear

Failure Load: 52400 lbs/bolt

Max Deflection $\Delta_{max}=0.33$ in.

Failure Plate: N/A

COMMENTS

- * PL-33 yielded at 37500 lbs, 0.055 in. of deformation.
- * PL-31 yielded at 45000 lbs and 0.12 in. of deformation.
- * PL-33 bulged at 48000 lbs, 0.25 in. of deformation.

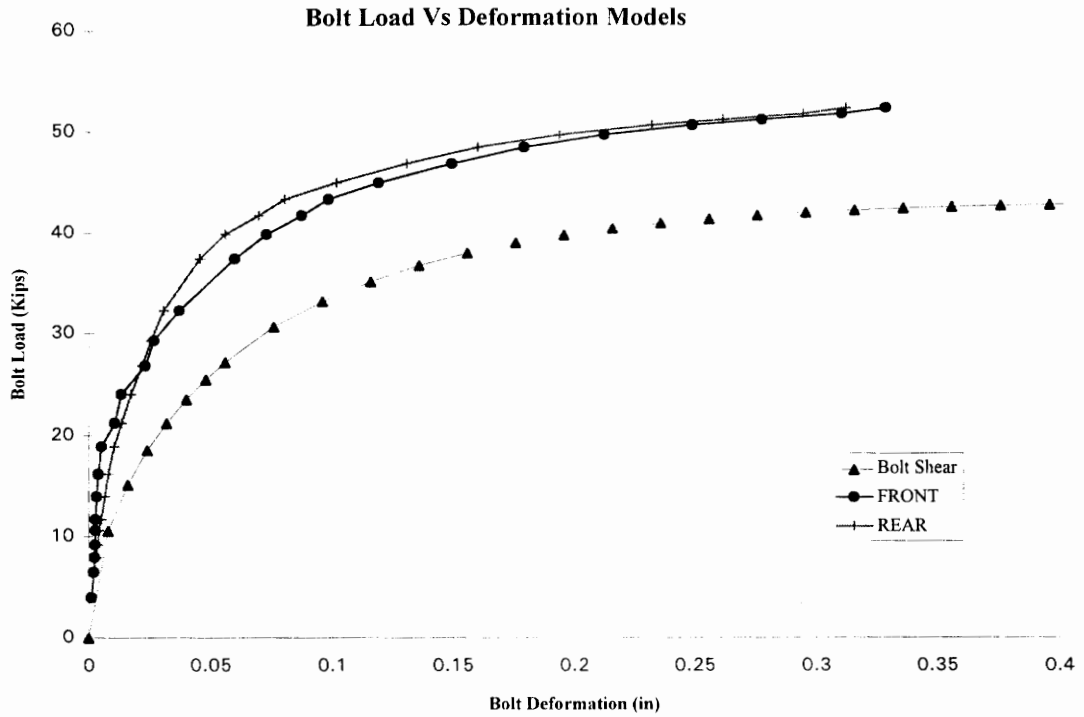

Figure C-42

Plate	tp	Fu	B/T	Bolt	A325
Plate 1	0.5	74	64.75	Bolt Dia.	0.875
Plate 2	1	67.8	118.65	Fv	72
				Bolt Shear	43.29

Richard Coefficients

K= 0 Kp= 0 Ro= 0
 K1= 0 n= 0

Data Point	Volts	Load	F1	F2	F3	F4	R1	R2	R3	R4	AVG(F)	AVG(R)
1	0.26	3.96	-0.001	0.000	-0.002	-0.002	-0.002	-0.001	-0.001	0.000	0.001	0.001
2	0.43	6.52	-0.001	-0.001	-0.004	-0.003	-0.004	-0.003	-0.001	0.000	0.002	0.002
3	0.53	7.98	-0.001	-0.001	-0.004	-0.004	-0.007	-0.004	-0.002	0.000	0.002	0.003
4	0.62	9.23	-0.001	-0.001	-0.004	-0.004	-0.009	-0.004	-0.002	0.000	0.003	0.004
5	0.71	10.63	-0.002	-0.001	-0.004	-0.004	-0.010	-0.005	-0.002	0.001	0.003	0.004
6	0.78	11.73	-0.002	-0.001	-0.004	-0.004	-0.012	-0.006	-0.004	0.001	0.003	0.005
7	0.93	14.00	-0.003	-0.002	-0.004	-0.004	-0.016	-0.007	-0.005	0.002	0.003	0.007
8	1.08	16.20	-0.003	-0.002	-0.005	-0.006	-0.020	-0.007	-0.007	0.002	0.004	0.008
9	1.26	18.91	-0.003	-0.003	-0.007	-0.008	-0.027	-0.006	-0.013	0.005	0.005	0.011
10	1.42	21.25	-0.009	-0.006	-0.014	-0.013	-0.037	-0.005	-0.021	0.009	0.011	0.014
11	1.60	24.03	-0.012	-0.008	-0.018	-0.017	-0.049	-0.002	-0.031	0.013	0.013	0.017
12	1.79	26.87	-0.020	-0.017	-0.029	-0.028	-0.064	0.002	-0.044	0.019	0.023	0.022
13	1.95	29.31	-0.023	-0.020	-0.032	-0.032	-0.075	0.004	-0.053	0.022	0.027	0.026
14	2.15	32.31	-0.032	-0.030	-0.044	-0.043	-0.092	0.007	-0.067	0.029	0.037	0.031
15	2.50	37.45	-0.053	-0.051	-0.069	-0.067	-0.129	0.008	-0.098	0.036	0.060	0.046
16	2.66	39.86	-0.065	-0.063	-0.083	-0.081	-0.150	0.005	-0.115	0.036	0.073	0.056
17	2.78	41.77	-0.078	-0.077	-0.099	-0.095	-0.172	-0.004	-0.134	0.031	0.087	0.070
18	2.89	43.38	-0.088	-0.087	-0.111	-0.108	-0.187	-0.012	-0.147	0.024	0.098	0.080
19	3.00	44.99	-0.108	-0.107	-0.132	-0.130	-0.215	-0.029	-0.172	0.009	0.119	0.102
20	3.13	46.89	-0.137	-0.137	-0.162	-0.162	-0.250	-0.054	-0.205	-0.013	0.150	0.131
21	3.23	48.51	-0.166	-0.166	-0.193	-0.194	-0.285	-0.081	-0.237	-0.039	0.180	0.160
22	3.32	49.75	-0.197	-0.199	-0.226	-0.228	-0.321	-0.114	-0.273	-0.069	0.213	0.194
23	3.38	50.70	-0.232	-0.234	-0.265	-0.265	-0.362	-0.150	-0.312	-0.105	0.249	0.232
24	3.41	51.21	-0.261	-0.262	-0.294	-0.294	-0.394	-0.179	-0.342	-0.132	0.278	0.262
25	3.45	51.80	-0.293	-0.295	-0.327	-0.328	-0.429	-0.210	-0.377	-0.163	0.311	0.295
26	3.49	52.39	-0.311	-0.313	-0.346	-0.346	-0.448	-0.227	-0.395	-0.180	0.329	0.312

Table C-42

TENSION TESTS ON BOLTED CONNECTIONS

SUMMARY SHEET

Test No: 43

Date: April 3, 1995

Test Designation: 3/4x3/4x7/8

Recorder: Burak Karsu

GEOMETRIC AND MATERIAL PROPERTIES

BOLT

Type: A325 Diameter $d_b=0.875$ in. Length $L_b=3.0$ in.

Shear Str. $F_v=72$ ksi Edge Dist. $e=1.75$ in. Fully Pretensioned--Yes

Bolt Hole Fabr.--Drilled Bolt Hole Type--Standard

Threads in Shear Plane--X

PLATES

No	Designation	Length (in.)	Width (in.)	Thickness (in.)	Hole Dia. (in.)	Fy (ksi)	Fu (ksi)
Plate 1	PL-29	24.0	4.0	0.75	15/16	44.6	70.4
Plate 2	PL-29	24.0	4.0	0.75	15/16	44.6	70.4

TEST RESULTS

Failure Type: Bolt Shear

Failure Load: 50000 lbs/bolt

Max Deflection $\Delta_{max}=0.28$ in.

Failure Plate: N/A

COMMENTS

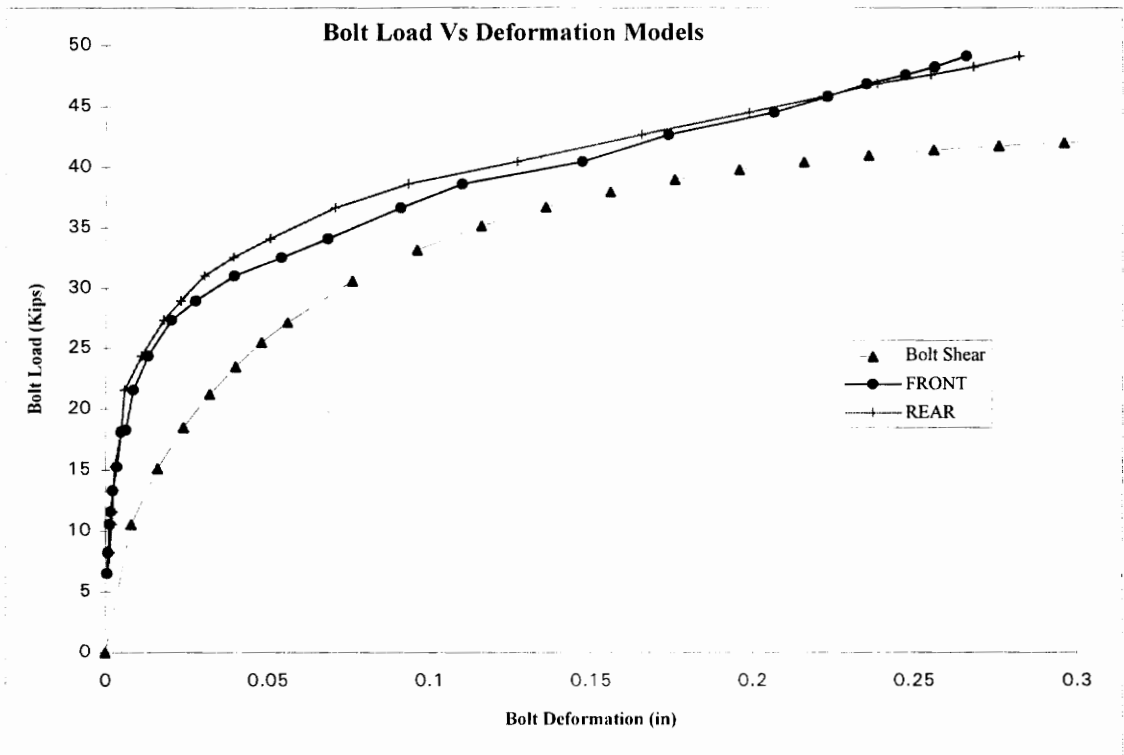

Figure C-43

Plate				Bolt	
	tp	Fu	B/T	Bolt Dia.	A325
Plate 1	0.75	70.4	92.40	Fv	72
Plate 2	0.75	70.4	92.40	Bolt Shear	43.29

Richard Coefficients

K= 0 Kp= 0 Ro= 0
 K1= 0 n= 0

Data Point	Volts	Load	F1	F2	F3	F4	R1	R2	R3	R4	AVG(F)	AVG(R)
1	0.17	6.56	-0.001	0.000	-0.001	0.000	-0.001	-0.001	-0.001	-0.001	0.000	0.001
2	0.28	8.25	-0.001	0.000	-0.002	0.001	-0.001	-0.002	-0.001	-0.001	0.001	0.001
3	0.44	10.59	-0.002	0.000	-0.004	0.001	-0.002	-0.003	-0.001	-0.002	0.001	0.002
4	0.51	11.62	-0.004	0.000	-0.004	0.001	-0.002	-0.003	-0.002	-0.002	0.002	0.002
5	0.62	13.30	-0.004	0.000	-0.006	0.001	-0.003	-0.003	-0.002	-0.002	0.002	0.003
6	0.75	15.28	-0.017	-0.015	-0.019	0.005	-0.004	-0.005	-0.005	-0.002	0.004	0.003
7	0.94	18.14	-0.019	-0.015	-0.022	0.005	-0.006	-0.005	-0.006	-0.002	0.005	0.005
8	0.95	18.28	-0.027	-0.024	-0.030	0.004	-0.013	-0.010	-0.015	-0.007	0.006	0.005
9	1.17	21.59	-0.031	-0.024	-0.035	0.003	-0.017	-0.013	-0.019	-0.010	0.009	0.006
10	1.36	24.37	-0.037	-0.024	-0.042	-0.001	-0.024	-0.017	-0.025	-0.014	0.013	0.011
11	1.56	27.37	-0.045	-0.027	-0.052	-0.010	-0.032	-0.023	-0.034	-0.020	0.020	0.018
12	1.67	28.98	-0.051	-0.035	-0.059	-0.018	-0.038	-0.028	-0.039	-0.024	0.028	0.023
13	1.80	31.04	-0.063	-0.047	-0.072	-0.029	-0.046	-0.035	-0.046	-0.030	0.040	0.030
14	1.90	32.57	-0.077	-0.062	-0.085	-0.044	-0.055	-0.045	-0.055	-0.039	0.054	0.039
15	2.01	34.11	-0.095	-0.068	-0.102	-0.061	-0.066	-0.057	-0.065	-0.050	0.069	0.051
16	2.18	36.68	-0.119	-0.084	-0.127	-0.086	-0.085	-0.079	-0.085	-0.070	0.091	0.071
17	2.31	38.66	-0.145	-0.084	-0.152	-0.111	-0.108	-0.105	-0.107	-0.089	0.110	0.093
18	2.43	40.49	-0.163	-0.151	-0.184	-0.144	-0.139	-0.139	-0.136	-0.131	0.147	0.127
19	2.58	42.69	-0.163	-0.180	-0.223	-0.182	-0.176	-0.181	-0.173	-0.168	0.174	0.166
20	2.70	44.52	-0.164	-0.243	-0.256	-0.216	-0.206	-0.214	-0.206	-0.206	0.207	0.199
21	2.79	45.84	-0.165	-0.243	-0.289	-0.250	-0.235	-0.245	-0.236	-0.207	0.223	0.222
22	2.86	46.86	-0.165	-0.243	-0.312	-0.273	-0.257	-0.269	-0.258	-0.207	0.235	0.238
23	2.91	47.60	-0.165	-0.243	-0.336	-0.297	-0.278	-0.291	-0.280	-0.207	0.247	0.255
24	2.95	48.26	-0.165	-0.243	-0.355	-0.315	-0.295	-0.310	-0.297	-0.207	0.256	0.268
25	3.01	49.14	-0.165	-0.243	-0.374	-0.335	-0.314	-0.329	-0.316	-0.207	0.266	0.282

Table C-43

TENSION TESTS ON BOLTED CONNECTIONS

SUMMARY SHEET

Test No: 44

Date: April 3, 1995

Test Designation: 3/4x1x7/8

Recorder: Burak Karsu

GEOMETRIC AND MATERIAL PROPERTIES

BOLT

Type:A325 Diameter $d_b=0.875$ in. Length $L_b= 3.25$ in.

Shear Str. $F_v=72$ ksi Edge Dist. $e=1.75$ in. Fully Pretensioned--Yes

Bolt Hole Fabr.--Drilled

Bolt Hole Type--Standard

Threads in Shear Plane--X

PLATES

No	Designation	Length (in.)	Width (in.)	Thickness (in.)	Hole Dia. (in.)	Fy (ksi)	Fu (ksi)
Plate 1	PL-29	24.0	4.0	0.75	15/16	44.6	70.4
Plate 2	PL-30	24.0	4.0	1.0	15/16	40.4	66.4

TEST RESULTS

Failure Type: Bolt Shear

Failure Load: 52800 lbs/bolt

Max Deflection $\Delta_{max}= 0.28$ in.

Failure Plate: N/A

COMMENTS

* PL-29 yielded at 30500 lbs, 0.03 in.

* PL-30 yielded at 42000 lbs, .085 in.

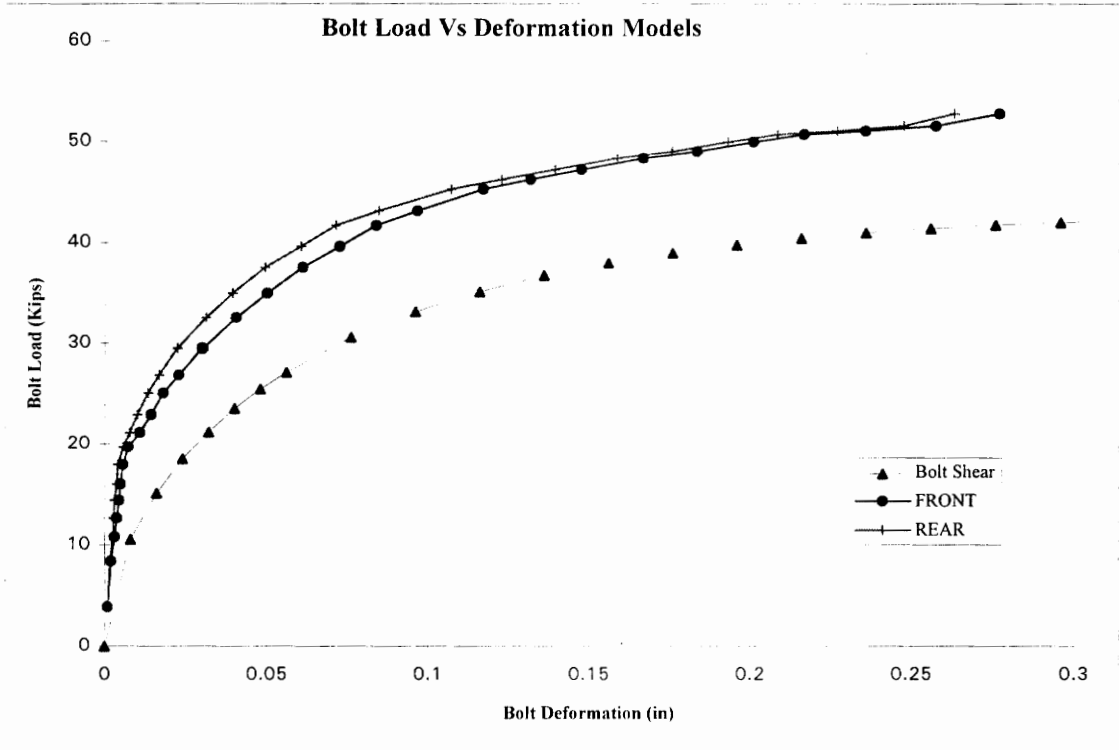

Figure C-44

Plate	tp	Fu	B/T	Bolt	A325
Plate 1	0.75	70.4	92.40	Bolt Dia.	0.875
Plate 2	1	66.4	116.20	Fv	72
				Bolt Shear	43.29

Richard Coefficients

K= 0 Kp= 0 Ro= 0
 K1= 0 n= 0

Data Point	Volts	Load	F1	F2	F3	F4	R1	R2	R3	R4	AVG(F)	AVG(R)
1	0.26	3.88	-0.002	-0.001	-0.001	0.000	-0.001	0.000	-0.002	-0.001	0.001	0.001
2	0.56	8.42	-0.005	-0.002	-0.001	0.000	-0.002	0.000	-0.004	-0.001	0.002	0.002
3	0.72	10.80	-0.006	-0.004	-0.002	-0.001	-0.002	0.000	-0.006	-0.002	0.003	0.003
4	0.84	12.67	-0.007	-0.006	-0.002	-0.001	-0.002	0.000	-0.007	-0.002	0.004	0.003
5	0.96	14.43	-0.008	-0.006	-0.002	-0.002	-0.002	-0.001	-0.007	-0.002	0.004	0.003
6	1.07	16.05	-0.009	-0.007	-0.002	-0.002	-0.003	-0.001	-0.009	-0.002	0.005	0.004
7	1.20	17.95	-0.009	-0.009	-0.002	-0.002	-0.003	-0.001	-0.010	-0.003	0.006	0.004
8	1.31	19.71	-0.012	-0.013	-0.002	-0.003	-0.004	-0.002	-0.012	-0.006	0.007	0.006
9	1.41	21.18	-0.015	-0.018	-0.003	-0.007	-0.006	-0.003	-0.014	-0.007	0.011	0.008
10	1.53	22.93	-0.018	-0.024	-0.005	-0.010	-0.009	-0.004	-0.018	-0.009	0.014	0.010
11	1.67	25.06	-0.021	-0.029	-0.007	-0.015	-0.013	-0.006	-0.024	-0.010	0.018	0.013
12	1.79	26.89	-0.026	-0.037	-0.009	-0.020	-0.019	-0.006	-0.030	-0.012	0.023	0.017
13	1.97	29.53	-0.033	-0.048	-0.012	-0.028	-0.027	-0.009	-0.039	-0.014	0.030	0.022
14	1.96	29.45	-0.034	-0.048	-0.012	-0.028	-0.027	-0.009	-0.039	-0.014	0.030	0.022
15	2.17	32.60	-0.044	-0.064	-0.016	-0.039	-0.040	-0.013	-0.053	-0.019	0.041	0.031
16	2.33	35.02	-0.054	-0.080	-0.020	-0.047	-0.050	-0.017	-0.066	-0.024	0.050	0.039
17	2.51	37.59	-0.065	-0.097	-0.024	-0.057	-0.063	-0.022	-0.081	-0.032	0.061	0.049
18	2.64	39.64	-0.076	-0.114	-0.031	-0.069	-0.076	-0.028	-0.097	-0.041	0.072	0.060
19	2.78	41.69	-0.087	-0.130	-0.037	-0.081	-0.087	-0.035	-0.112	-0.051	0.084	0.071
20	2.88	43.16	-0.100	-0.147	-0.046	-0.094	-0.103	-0.043	-0.130	-0.062	0.097	0.085
21	3.02	45.28	-0.118	-0.173	-0.062	-0.116	-0.126	-0.062	-0.157	-0.083	0.117	0.107
22	3.08	46.23	-0.132	-0.190	-0.074	-0.131	-0.143	-0.075	-0.175	-0.098	0.132	0.123
23	3.15	47.19	-0.146	-0.208	-0.087	-0.149	-0.161	-0.091	-0.193	-0.114	0.148	0.139
24	3.22	48.37	-0.164	-0.229	-0.106	-0.169	-0.181	-0.108	-0.213	-0.132	0.167	0.159
25	3.27	49.02	-0.180	-0.247	-0.122	-0.187	-0.199	-0.123	-0.232	-0.149	0.184	0.176
26	3.33	49.97	-0.198	-0.266	-0.138	-0.204	-0.217	-0.139	-0.250	-0.167	0.201	0.193
27	3.38	50.71	-0.212	-0.281	-0.153	-0.221	-0.233	-0.154	-0.266	-0.181	0.217	0.209
28	3.40	51.07	-0.230	-0.302	-0.172	-0.240	-0.252	-0.172	-0.285	-0.200	0.236	0.227
29	3.44	51.58	-0.252	-0.324	-0.193	-0.262	-0.273	-0.192	-0.306	-0.219	0.258	0.248
30	3.52	52.79	-0.271	-0.344	-0.212	-0.281	-0.290	-0.207	-0.323	-0.233	0.277	0.263

Table C-44

TENSION TESTS ON BOLTED CONNECTIONS

SUMMARY SHEET

Test No: 45

Date: April 3, 1995

Test Designation: 1x1x7/8

Recorder: Burak Karsu

GEOMETRIC AND MATERIAL PROPERTIES

BOLT

Type:A325

Diameter $d_b=0.875$ in.

Length $L_b= 3.5$ in.

Shear Str. $F_v=72$ ksi

Edge Dist. $e=1.75$ in.

Fully Pretensioned--Yes

Bolt Hole Fabr.--Drilled

Bolt Hole Type--Standard

Threads in Shear Plane--X

PLATES

No	Designation	Length (in.)	Width (in.)	Thickness (in.)	Hole Dia. (in.)	Fy (ksi)	Fu (ksi)
Plate 1	PL-32	24.0	4.0	1.0	15/16	41.5	67.6
Plate 2	PL-32	24.0	4.0	1.0	15/16	41.5	67.6

TEST RESULTS

Failure Type: Bolt Shear

Failure Load: 54000 lbs/bolt

Max Deflection $\Delta_{max}= 0.23$ in.

Failure Plate: N/A

COMMENTS

* PL-32 yielded at 43000 lbs, 0.05 in.

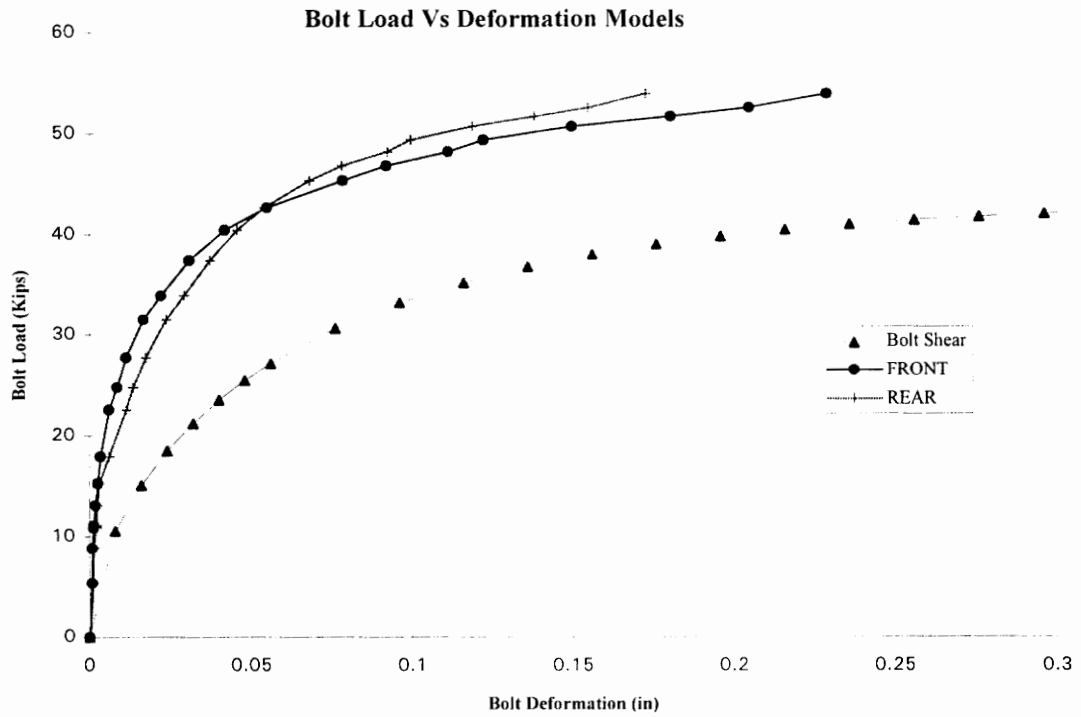

Figure C-45

Plate				Bolt	A325
	tp	Fu	B/T	Bolt Dia.	0.875
Plate 1	1	67.6	118.30	Fv	72
Plate 2	1	67.6	118.30	Bolt Shear	43.29

Richard Coefficients

K= 0 Kp= 0 Ro= 0
 K1= 0 n= 0

Data Point	Volts	Load	F1	F2	F3	F4	R1	R2	R3	R4	AVG(F)	AVG(R)
1	0.00	0.00	0.000	0.000	0.000	0.000	0.000	0.000	-0.001	0.000	0.000	0.000
2	0.36	5.35	-0.001	-0.001	-0.001	0.000	-0.001	-0.001	-0.002	-0.001	0.001	0.001
3	0.59	8.86	-0.001	-0.001	-0.002	0.000	-0.002	-0.001	-0.002	-0.001	0.001	0.001
4	0.74	11.14	-0.002	-0.002	-0.002	0.000	-0.003	-0.002	-0.002	-0.001	0.001	0.002
5	0.73	10.91	-0.002	-0.002	-0.001	0.000	-0.003	-0.002	-0.003	-0.001	0.001	0.002
6	0.87	13.11	-0.002	-0.003	-0.002	0.000	-0.004	-0.002	-0.003	-0.001	0.002	0.002
7	1.02	15.31	-0.004	-0.003	-0.002	-0.001	-0.003	-0.004	-0.003	-0.002	0.003	0.003
8	1.20	17.95	-0.005	-0.003	-0.004	-0.002	-0.002	-0.011	-0.003	-0.009	0.003	0.006
9	1.50	22.57	-0.011	-0.002	-0.010	-0.002	-0.001	-0.022	-0.002	-0.020	0.006	0.011
10	1.65	24.77	-0.017	-0.001	-0.015	0.000	-0.001	-0.026	-0.002	-0.024	0.009	0.013
11	1.85	27.77	-0.024	0.000	-0.022	0.001	-0.001	-0.034	-0.003	-0.031	0.011	0.017
12	2.10	31.50	-0.037	0.000	-0.032	0.003	-0.005	-0.043	-0.007	-0.040	0.017	0.024
13	2.26	33.93	-0.046	-0.002	-0.042	0.001	-0.010	-0.050	-0.011	-0.047	0.022	0.029
14	2.50	37.44	-0.060	-0.007	-0.054	-0.002	-0.017	-0.059	-0.018	-0.055	0.031	0.037
15	2.70	40.45	-0.074	-0.015	-0.069	-0.010	-0.025	-0.069	-0.025	-0.064	0.042	0.046
16	2.84	42.65	-0.091	-0.026	-0.083	-0.020	-0.033	-0.078	-0.034	-0.072	0.055	0.054
17	3.02	45.36	-0.118	-0.050	-0.108	-0.038	-0.048	-0.092	-0.046	-0.085	0.078	0.068
18	3.12	46.82	-0.133	-0.063	-0.122	-0.050	-0.059	-0.103	-0.057	-0.094	0.092	0.078
19	3.21	48.21	-0.157	-0.081	-0.141	-0.066	-0.073	-0.117	-0.070	-0.108	0.111	0.092
20	3.29	49.38	-0.169	-0.092	-0.152	-0.076	-0.081	-0.125	-0.078	-0.115	0.122	0.100
21	3.38	50.70	-0.198	-0.120	-0.180	-0.101	-0.100	-0.146	-0.097	-0.133	0.150	0.119
22	3.44	51.65	-0.232	-0.151	-0.209	-0.129	-0.120	-0.167	-0.114	-0.151	0.181	0.138
23	3.50	52.53	-0.258	-0.176	-0.233	-0.152	-0.138	-0.185	-0.130	-0.167	0.205	0.155
24	3.60	53.93	-0.283	-0.202	-0.257	-0.175	-0.158	-0.203	-0.147	-0.184	0.229	0.173

Table C-45

TENSION TESTS ON BOLTED CONNECTIONS

SUMMARY SHEET

Test No: 46

Date: April 4, 1995

Test Designation: 1/4x1/4x1

Recorder: Burak Karsu

GEOMETRIC AND MATERIAL PROPERTIES

BOLT

Type:A325

Diameter $d_b=1.0$ in.

Length $L_b= 2.25$ in.

Shear Str. $F_v=72$ ksi

Edge Dist. $e=2.0$ in.

Fully Pretensioned--Yes

Bolt Hole Fabr.--Drilled

Bolt Hole Type--Standard

Threads in Shear Plane--X

PLATES

<u>No</u>	<u>Designation</u>	<u>Length</u> <u>(in.)</u>	<u>Width</u> <u>(in.)</u>	<u>Thickness</u> <u>(in.)</u>	<u>Hole Dia.</u> <u>(in.)</u>	<u>Fy</u> <u>(ksi)</u>	<u>Fu</u> <u>(ksi)</u>
Plate 1	PL-20	24.0	4.0	0.25	17/16	46.1	66.2
Plate 2	PL-20	24.0	4.0	0.25	17/16	46.1	66.2

TEST RESULTS

Failure Type: Splitting at the edge of the plate.

Failure Load: 38000 lbs/bolt

Max Deflection $\Delta_{max}=1.3$ in.

Failure Plate: PL-20

COMMENTS

* PL-20 yielded at 18000 lbs

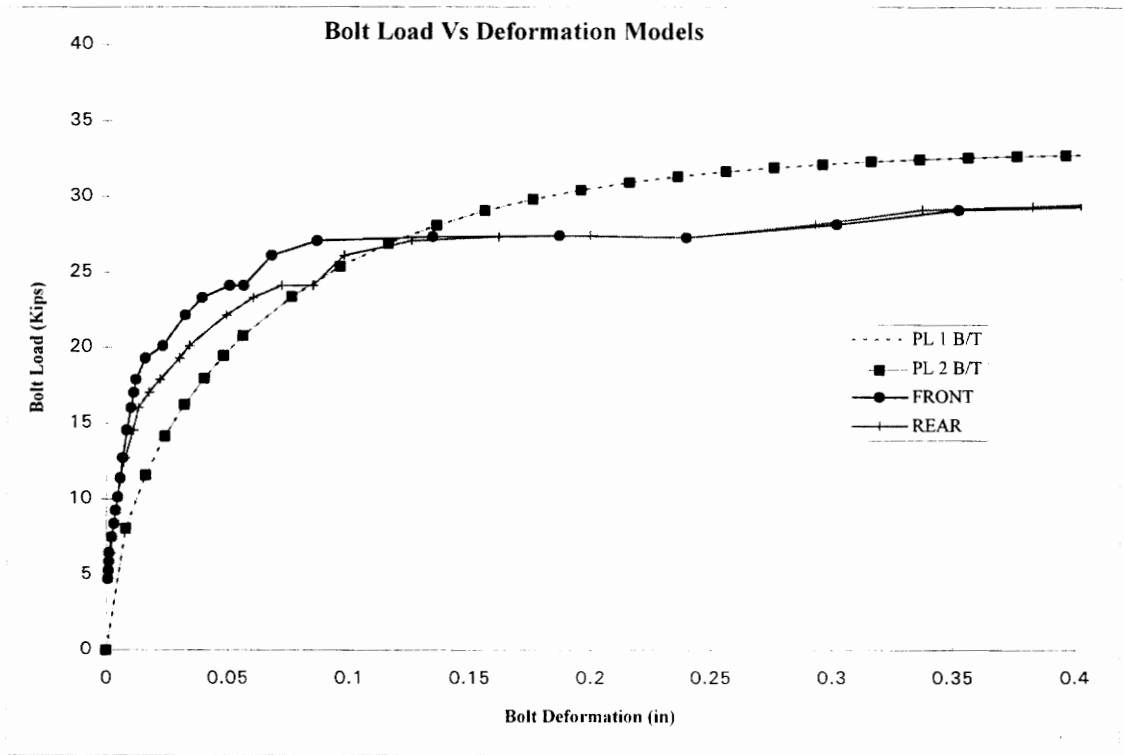

Figure C-46

Plate		Bolt		A325	
	tp	Fu	B/T	Bolt Dia.	
Plate 1	0.25	66.2	33.10	Fv	72
Plate 2	0.25	66.2	33.10	Bolt Shear	56.55

Richard Coefficients

K= 0 Kp= 0 Ro= 0
 K1= 0 n= 0

Data Point	Volts	Load	F1	F2	F3	F4	R1	R2	R3	R4	AVG(F)	AVG(R)
1	0.01	4.72	-0.001	0.000	-0.001	-0.001	0.000	-0.001	0.000	-0.001	0.001	0.000
2	0.05	5.31	-0.001	-0.001	-0.001	-0.001	-0.001	-0.002	-0.001	-0.001	0.001	0.001
3	0.09	5.89	-0.001	-0.001	-0.002	-0.001	-0.001	-0.002	-0.001	-0.001	0.001	0.001
4	0.13	6.48	-0.001	-0.001	-0.002	-0.001	-0.001	-0.003	-0.001	-0.002	0.001	0.002
5	0.20	7.50	-0.002	-0.001	-0.004	-0.002	-0.003	-0.003	-0.002	-0.002	0.002	0.002
6	0.26	8.38	-0.002	-0.002	-0.006	-0.003	-0.003	-0.004	-0.002	-0.004	0.003	0.003
7	0.32	9.26	-0.004	-0.002	-0.006	-0.004	-0.003	-0.006	-0.002	-0.006	0.004	0.004
8	0.38	10.14	-0.005	-0.002	-0.008	-0.004	-0.002	-0.007	-0.001	-0.008	0.005	0.005
9	0.46	11.38	-0.006	-0.002	-0.010	-0.005	-0.002	-0.009	-0.001	-0.010	0.006	0.006
10	0.55	12.71	-0.007	-0.004	-0.010	-0.006	-0.003	-0.013	-0.001	-0.013	0.007	0.007
11	0.67	14.54	-0.009	-0.004	-0.013	-0.007	-0.005	-0.017	-0.004	-0.018	0.008	0.011
12	0.77	16.01	-0.010	-0.006	-0.016	-0.009	-0.008	-0.018	-0.007	-0.019	0.010	0.013
13	0.84	17.03	-0.012	-0.006	-0.018	-0.009	-0.012	-0.021	-0.012	-0.024	0.011	0.017
14	0.89	17.91	-0.013	-0.006	-0.019	-0.010	-0.017	-0.027	-0.016	-0.028	0.012	0.022
15	0.99	19.30	-0.017	-0.009	-0.023	-0.013	-0.024	-0.036	-0.023	-0.037	0.016	0.030
16	1.04	20.11	-0.023	-0.019	-0.029	-0.021	-0.028	-0.042	-0.025	-0.040	0.023	0.034
17	1.18	22.16	-0.029	-0.030	-0.037	-0.033	-0.043	-0.058	-0.039	-0.056	0.032	0.049
18	1.26	23.33	-0.035	-0.039	-0.043	-0.040	-0.053	-0.070	-0.050	-0.067	0.039	0.060
19	1.31	24.14	-0.045	-0.051	-0.053	-0.053	-0.065	-0.083	-0.061	-0.079	0.050	0.072
20	1.31	24.14	-0.050	-0.058	-0.058	-0.059	-0.078	-0.097	-0.073	-0.091	0.056	0.085
21	1.44	26.12	-0.061	-0.070	-0.070	-0.070	-0.091	-0.110	-0.086	-0.104	0.068	0.098
22	1.51	27.08	-0.079	-0.090	-0.088	-0.089	-0.119	-0.138	-0.113	-0.132	0.087	0.126
23	1.52	27.36	-0.127	-0.138	-0.137	-0.136	-0.155	-0.174	-0.150	-0.168	0.134	0.162
24	1.53	27.44	-0.179	-0.192	-0.189	-0.188	-0.193	-0.212	-0.188	-0.206	0.187	0.200
25	1.52	27.29	-0.232	-0.245	-0.241	-0.242	-0.235	-0.252	-0.229	-0.245	0.240	0.240
26	1.58	28.18	-0.294	-0.307	-0.303	-0.305	-0.287	-0.305	-0.281	-0.298	0.302	0.293
27	1.64	29.13	-0.343	-0.357	-0.353	-0.355	-0.332	-0.349	-0.327	-0.341	0.352	0.337
28	1.66	29.35	-0.395	-0.410	-0.405	-0.406	-0.378	-0.395	-0.372	-0.386	0.404	0.383
29	1.68	29.63	-0.443	-0.456	-0.451	-0.451	-0.418	-0.435	-0.413	-0.426	0.450	0.423
30	1.70	30.01	-0.500	-0.515	-0.509	-0.510	-0.474	-0.490	-0.468	-0.480	0.509	0.478
31	1.74	30.59	-0.595	-0.610	-0.603	-0.603	-0.566	-0.582	-0.561	-0.572	0.603	0.570
32	1.78	31.18	-0.693	-0.711	-0.704	-0.703	-0.667	-0.683	-0.662	-0.672	0.703	0.671
33	1.82	31.83	-0.826	-0.840	-0.834	-0.830	-0.798	-0.813	-0.794	-0.804	0.833	0.802
34	1.89	32.86	-0.914	-0.930	-0.849	-0.921	-0.892	-0.906	-0.887	-0.893	0.903	0.894
35	1.94	33.60	-1.023	-0.993	-1.036	-1.031	-1.003	-1.016	-0.999	-1.008	1.021	1.006
36	2.00	34.47	-1.123	-1.139	-1.138	-1.134	-1.102	-1.117	-1.098	-1.104	1.133	1.105
37	2.06	35.35	-1.174	-1.170	-1.192	-1.183	-1.173	-1.136	-1.169	-1.161	1.180	1.160
38	2.15	36.74	-1.214	-1.172	-1.235	-1.149	-1.210	-1.135	-1.270	-1.276	1.192	1.222
39	2.24	38.06	-1.345	-1.173	-1.537	-1.149	-1.210	-1.135	-1.270	-1.276	1.301	1.223

Table C-46

TENSION TESTS ON BOLTED CONNECTIONS

SUMMARY SHEET

Test No: 47

Date: April 4, 1995

Test Designation: 1/4x3/8x1

Recorder: Burak Karsu

GEOMETRIC AND MATERIAL PROPERTIES

BOLT

Type: A325 Diameter $d_b=1.0$ in. Length $L_b=2.25$ in.

Shear Str. $F_v=72$ ksi Edge Dist. $e=2.0$ in. Fully Pretensioned--Yes

Bolt Hole Fabr.--Drilled Bolt Hole Type--Standard

Threads in Shear Plane--X

PLATES

<u>No</u>	<u>Designation</u>	<u>Length</u> <u>(in.)</u>	<u>Width</u> <u>(in.)</u>	<u>Thickness</u> <u>(in.)</u>	<u>Hole Dia.</u> <u>(in.)</u>	<u>Fy</u> <u>(ksi)</u>	<u>Fu</u> <u>(ksi)</u>
Plate 1	PL-20	24.0	4.0	0.25	17/16	46.1	66.2
Plate 2	PL-25	24.0	4.0	0.37	17/16	43.7	63.7

TEST RESULTS

Failure Type: Bearing/ Tear Out

Failure Load: 33500 lbs/plate

Max Deflection $\Delta_{max}=0.56$ in.

Failure Plate: PL-20

COMMENTS

- * PL-20 started yielding at 25700 lbs, 0.035 in.
- * PL-25 started yielding at 29000 lbs with 0.065 in of deformation.
- * Bulging on PL-20 started at 0.19 in. of deformation with 33000 lbs.

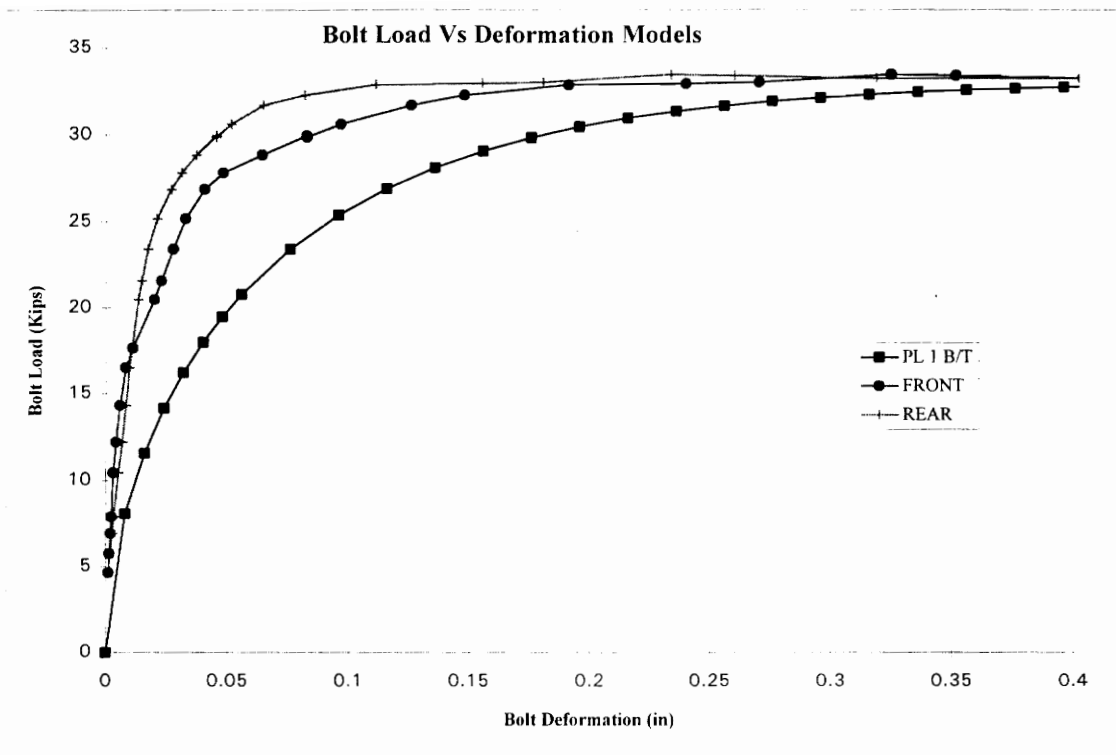

Figure C-47

Plate				Bolt		A325
	tp	Fu	B/T	Bolt Dia.		
Plate 1	0.25	66.2	33.10	Fv		72
Plate 2	0.375	63.7	47.78	Bolt Shear		56.55

Richard Coefficients

$K = 0$ $K_p = 0$ $R_o = 0$
 $K_1 = 0$ $n = 0$

Data Point	Volts	Load	F1	F2	F3	F4	R1	R2	R3	R4	AVG(F)	AVG(R)
1	0.12	4.66	-0.001	-0.001	-0.002	-0.001	-0.002	-0.002	0.000	0.001	0.001	0.001
2	0.19	5.76	-0.001	-0.001	-0.002	-0.002	-0.004	-0.004	0.000	0.001	0.002	0.002
3	0.27	6.94	-0.001	-0.001	-0.004	-0.002	-0.006	-0.006	0.000	0.001	0.002	0.003
4	0.33	7.89	-0.001	-0.002	-0.004	-0.003	-0.007	-0.007	0.000	0.001	0.002	0.003
5	0.50	10.45	-0.002	-0.002	-0.005	-0.004	-0.010	-0.011	0.000	0.000	0.003	0.005
6	0.62	12.21	-0.004	-0.003	-0.007	-0.004	-0.012	-0.013	-0.001	-0.001	0.004	0.007
7	0.76	14.33	-0.005	-0.003	-0.010	-0.006	-0.013	-0.017	-0.001	-0.003	0.006	0.008
8	0.91	16.53	-0.009	-0.004	-0.015	-0.006	-0.015	-0.019	-0.001	-0.004	0.008	0.010
9	0.98	17.64	-0.012	-0.006	-0.018	-0.009	-0.016	-0.021	0.000	-0.006	0.011	0.011
10	1.17	20.50	-0.018	-0.015	-0.027	-0.020	-0.018	-0.026	-0.002	-0.008	0.020	0.013
11	1.25	21.60	-0.020	-0.018	-0.030	-0.023	-0.018	-0.028	-0.002	-0.010	0.023	0.015
12	1.37	23.43	-0.023	-0.024	-0.034	-0.030	-0.020	-0.034	-0.002	-0.014	0.028	0.017
13	1.49	25.18	-0.026	-0.031	-0.038	-0.037	-0.021	-0.040	-0.003	-0.020	0.033	0.021
14	1.60	26.87	-0.031	-0.041	-0.044	-0.046	-0.027	-0.048	-0.006	-0.026	0.041	0.027
15	1.66	27.82	-0.037	-0.051	-0.050	-0.056	-0.030	-0.054	-0.011	-0.031	0.048	0.031
16	1.73	28.85	-0.052	-0.068	-0.064	-0.074	-0.035	-0.061	-0.015	-0.037	0.065	0.037
17	1.80	29.94	-0.068	-0.089	-0.081	-0.094	-0.042	-0.071	-0.023	-0.047	0.083	0.046
18	1.80	29.86	-0.068	-0.089	-0.081	-0.094	-0.042	-0.071	-0.023	-0.047	0.083	0.046
19	1.85	30.60	-0.081	-0.105	-0.094	-0.108	-0.048	-0.078	-0.028	-0.053	0.097	0.052
20	1.92	31.70	-0.108	-0.136	-0.121	-0.139	-0.060	-0.092	-0.040	-0.067	0.126	0.065
21	1.96	32.29	-0.130	-0.159	-0.143	-0.161	-0.077	-0.110	-0.057	-0.083	0.148	0.082
22	2.00	32.87	-0.172	-0.203	-0.185	-0.206	-0.103	-0.143	-0.084	-0.116	0.191	0.111
23	2.00	32.95	-0.220	-0.253	-0.232	-0.256	-0.145	-0.188	-0.127	-0.162	0.240	0.156
24	2.01	33.02	-0.249	-0.281	-0.263	-0.289	-0.168	-0.215	-0.154	-0.187	0.270	0.181
25	2.04	33.46	-0.302	-0.336	-0.319	-0.344	-0.220	-0.268	-0.207	-0.239	0.325	0.234
26	2.03	33.39	-0.329	-0.361	-0.345	-0.371	-0.248	-0.295	-0.232	-0.266	0.352	0.260
27	2.02	33.24	-0.380	-0.415	-0.396	-0.424	-0.307	-0.355	-0.290	-0.324	0.404	0.319
28	2.02	33.24	-0.447	-0.486	-0.465	-0.496	-0.393	-0.444	-0.377	-0.412	0.473	0.407
29	2.04	33.52	-0.448	-0.486	-0.465	-0.496	-0.393	-0.444	-0.377	-0.412	0.474	0.407
30	2.00	32.87	-0.527	-0.569	-0.547	-0.581	-0.523	-0.572	-0.502	-0.535	0.556	0.533

Table C-47

TENSION TESTS ON BOLTED CONNECTIONS

SUMMARY SHEET

Test No: 48

Date: April 4, 1995

Test Designation: 1/4x1/2x1

Recorder: Burak Karsu

GEOMETRIC AND MATERIAL PROPERTIES

BOLT

Type: A325 Diameter $d_b=1.0$ in. Length $L_b=2.25$ in.

Shear Str. $F_v=72$ ksi Edge Dist. $e=2.0$ in. Fully Pretensioned--Yes

Bolt Hole Fabr.--Drilled Bolt Hole Type--Standard

Threads in Shear Plane--X

PLATES

No	Designation	Length (in.)	Width (in.)	Thickness (in.)	Hole Dia. (in.)	Fy (ksi)	Fu (ksi)
Plate 1	PL-40	24.0	4.0	0.25	17/16	46.1	66.2
Plate 2	PL-12	24.0	4.0	0.5	17/16	51.5	74.5

TEST RESULTS

Failure Type: Splitting in the bulged part

Failure Load: 38200 lbs/plate

Max Deflection $\Delta_{max}=0.82$ in.

Failure Plate: PL-40

COMMENTS

- * PL-40 started yielding at 0.04in. of deformation with 29000 lbs.
- * At 35000 lbs, PL-40 started bulging in front of the bolt and PL-12 started yielding.
- * Split occurred at 0.95 in. of deformation.
- * Bearing / tear out also developed.

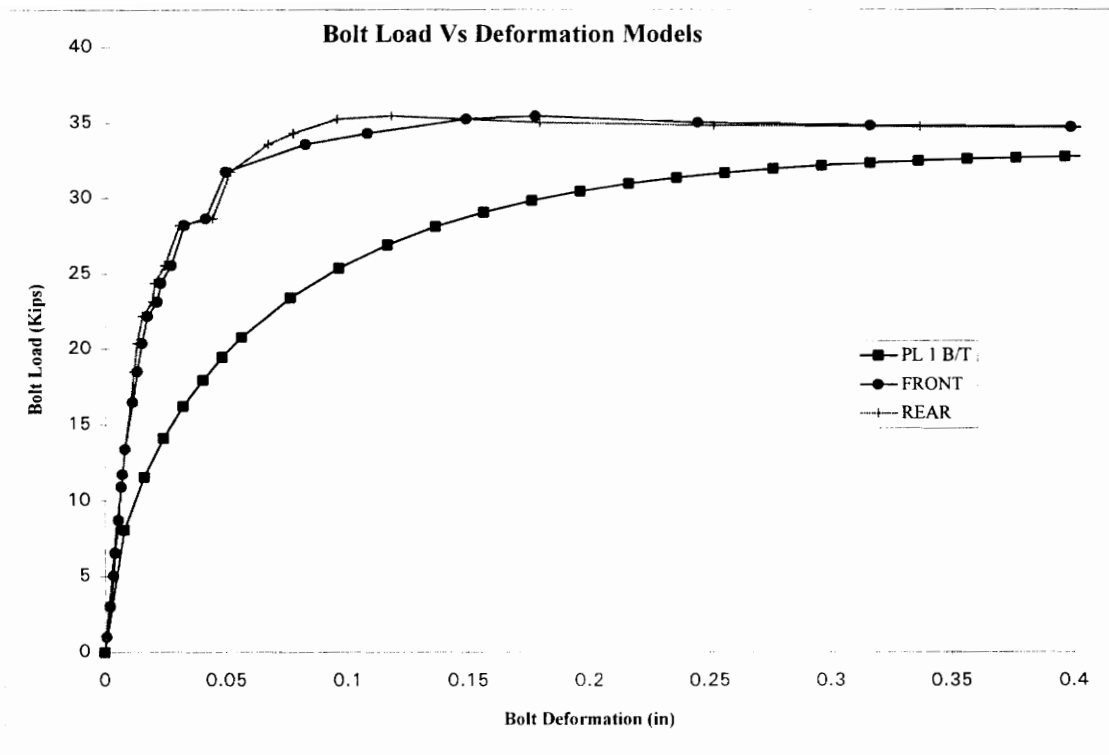

Figure C-48

Plate			Bolt		A325
	tp	Fu	B/T	Bolt Dia.	1
Plate 1	0.25	66.2	33.10	Fv	72
Plate 2	0.5	74.5	74.50	Bolt Shear	56.55

Richard Coefficients

K= 0 Kp= 0 Ro= 0
 K1= 0 n= 0

Data Point	Volts	Load	F1	F2	F3	F4	R1	R2	R3	R4	AVG(F)	AVG(R)
1	0.07	1.03	-0.001	0.001	-0.002	-0.001	-0.001	-0.001	0.000	0.001	0.001	0.000
2	0.20	3.00	-0.001	0.001	-0.005	-0.004	-0.004	-0.004	0.000	0.001	0.002	0.002
3	0.34	5.05	-0.001	0.001	-0.007	-0.007	-0.006	-0.007	0.000	0.001	0.004	0.003
4	0.44	6.54	-0.001	0.001	-0.009	-0.007	-0.007	-0.009	0.000	0.001	0.004	0.004
5	0.58	8.72	-0.001	0.001	-0.012	-0.010	-0.010	-0.012	0.000	0.001	0.006	0.005
6	0.73	10.92	-0.002	0.001	-0.013	-0.012	-0.013	-0.015	0.000	0.001	0.007	0.007
7	0.78	11.73	-0.002	0.001	-0.015	-0.012	-0.014	-0.016	0.000	0.001	0.007	0.007
8	0.89	13.41	-0.004	0.002	-0.018	-0.013	-0.015	-0.018	0.000	0.000	0.008	0.008
9	1.10	16.49	-0.007	0.003	-0.024	-0.017	-0.017	-0.023	0.000	-0.002	0.011	0.010
10	1.24	18.54	-0.010	0.004	-0.029	-0.018	-0.018	-0.025	0.000	-0.003	0.013	0.012
11	1.36	20.37	-0.012	0.004	-0.032	-0.019	-0.020	-0.028	0.000	-0.004	0.015	0.013
12	1.48	22.20	-0.016	0.004	-0.038	-0.020	-0.021	-0.033	0.001	-0.007	0.017	0.015
13	1.54	23.14	-0.021	0.002	-0.043	-0.023	-0.023	-0.039	-0.004	-0.012	0.021	0.019
14	1.63	24.40	-0.022	0.003	-0.047	-0.024	-0.023	-0.042	-0.003	-0.013	0.023	0.020
15	1.70	25.56	-0.028	0.001	-0.053	-0.028	-0.026	-0.047	-0.007	-0.018	0.027	0.024
16	1.88	28.21	-0.034	0.000	-0.062	-0.033	-0.030	-0.057	-0.010	-0.025	0.032	0.030
17	1.91	28.65	-0.043	-0.005	-0.075	-0.041	-0.042	-0.073	-0.022	-0.039	0.041	0.044
18	2.11	31.72	-0.053	-0.010	-0.086	-0.048	-0.047	-0.084	-0.025	-0.048	0.049	0.051
19	2.24	33.55	-0.088	-0.039	-0.122	-0.079	-0.058	-0.106	-0.037	-0.066	0.082	0.067
20	2.29	34.29	-0.115	-0.062	-0.150	-0.103	-0.066	-0.120	-0.043	-0.078	0.108	0.077
21	2.35	35.24	-0.157	-0.102	-0.193	-0.143	-0.081	-0.144	-0.057	-0.099	0.148	0.095
22	2.36	35.46	-0.185	-0.130	-0.221	-0.173	-0.102	-0.169	-0.077	-0.122	0.177	0.117
23	2.33	35.02	-0.251	-0.196	-0.289	-0.242	-0.166	-0.231	-0.136	-0.183	0.245	0.179
24	2.32	34.80	-0.323	-0.267	-0.359	-0.315	-0.238	-0.306	-0.207	-0.255	0.316	0.251
25	2.32	34.73	-0.404	-0.348	-0.443	-0.399	-0.323	-0.392	-0.291	-0.341	0.398	0.337
26	2.31	34.65	-0.506	-0.450	-0.547	-0.503	-0.431	-0.500	-0.399	-0.446	0.501	0.444
27	2.39	35.82	-0.668	-0.611	-0.711	-0.669	-0.596	-0.665	-0.560	-0.607	0.665	0.607
28	2.43	36.48	-0.757	-0.701	-0.799	-0.757	-0.682	-0.754	-0.647	-0.694	0.753	0.694
29	2.50	37.44	-0.843	-0.784	-0.884	-0.841	-0.766	-0.840	-0.728	-0.777	0.838	0.778
30	2.55	38.24	-0.927	-0.867	-0.970	-0.926	-0.856	-0.929	-0.819	-0.870	0.922	0.869

Table C-48

TENSION TESTS ON BOLTED CONNECTIONS

SUMMARY SHEET

Test No: 49

Date: April 5, 1995

Test Designation: 1/4x5/8x1

Recorder: Burak Karsu

GEOMETRIC AND MATERIAL PROPERTIES

BOLT

Type: A325

Diameter $d_b=1.0$ in.

Length $L_b=2.5$ in.

Shear Str. $F_v=72$ ksi

Edge Dist. $e=2.0$ in.

Fully Pretensioned--Yes

Bolt Hole Fabr.--Drilled

Bolt Hole Type--Standard

Threads in Shear Plane--X

PLATES

No	Designation	Length (in.)	Width (in.)	Thickness (in.)	Hole Dia. (in.)	Fy (ksi)	Fu (ksi)
Plate 1	PL-41	24.0	4.0	0.25	17/16	46.1	66.2
Plate 2	PL-27a	24.0	4.0	0.625	17/16	45.4	68.4

TEST RESULTS

Failure Type: Splitting in the bulged part.

Failure Load: 35400 lbs/plate

Max Deflection $\Delta_{max}=0.80$ in.

Failure Plate: PL-41

COMMENTS

- * PL-41 yielded at a deformation of 0.042 in. with a load of 32000 lbs.
- * Bulging on PL-41 occurred at 35000 lbs, tips curled back.
- * Splitting initiated at 0.73 in. of deformation.

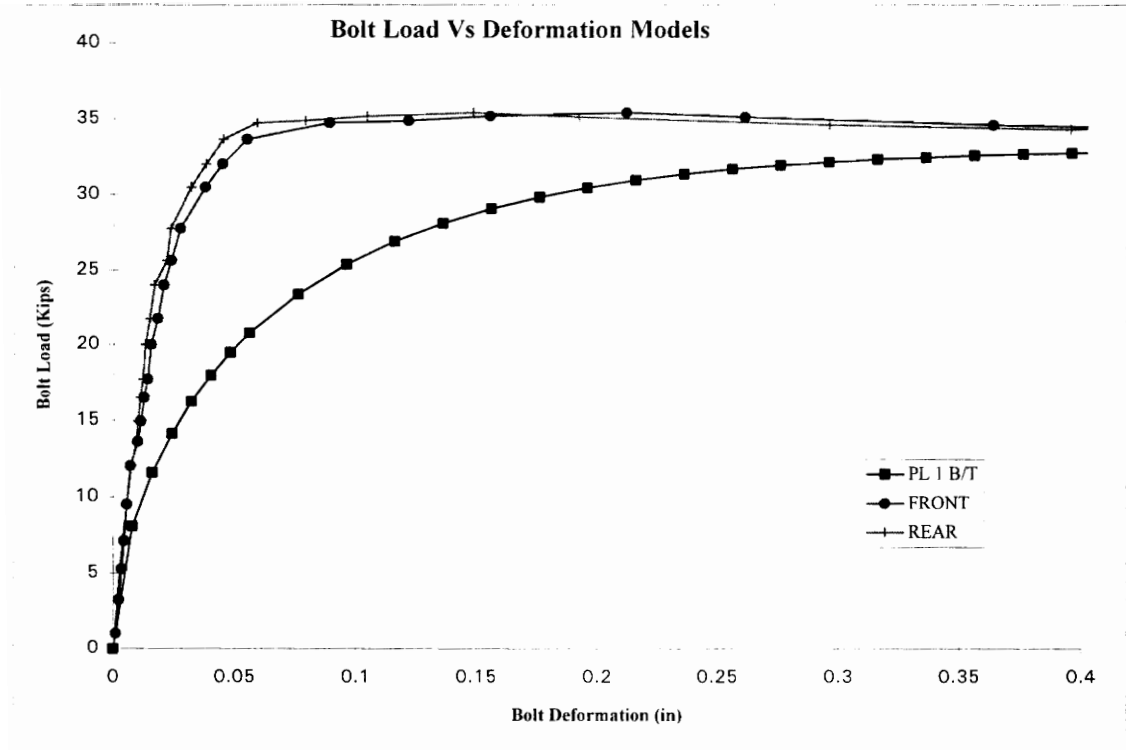

Figure C-49

Plate			Bolt		A325
	tp	Fu	B/T	Bolt Dia.	1
Plate 1	0.25	66.2	33.10	Fv	72
Plate 2	0.625	68.4	85.50	Bolt Shear	56.55

Richard Coefficients

$K = 0$ $K_p = 0$ $R_o = 0$
 $K_1 = 0$ $n = 0$

Data Point	Volts	Load	F1	F2	F3	F4	R1	R2	R3	R4	AVG(F)	AVG(R)
1	0.07	1.03	0.000	-0.001	-0.002	-0.002	-0.001	-0.001	-0.001	0.000	0.001	0.001
2	0.21	3.22	0.000	0.000	-0.006	-0.004	-0.004	-0.002	-0.001	0.000	0.002	0.002
3	0.35	5.27	0.000	0.001	-0.008	-0.007	-0.006	-0.005	-0.001	0.000	0.004	0.003
4	0.47	7.11	0.000	0.001	-0.010	-0.009	-0.009	-0.007	-0.001	0.001	0.005	0.004
5	0.64	9.53	0.000	0.001	-0.013	-0.010	-0.013	-0.010	-0.001	0.001	0.006	0.006
6	0.80	12.02	-0.001	0.001	-0.017	-0.012	-0.017	-0.013	0.000	0.001	0.007	0.007
7	0.91	13.63	-0.002	-0.001	-0.023	-0.015	-0.016	-0.018	-0.001	-0.002	0.010	0.009
8	1.00	14.95	-0.002	0.000	-0.026	-0.017	-0.017	-0.020	-0.001	-0.002	0.011	0.010
9	1.10	16.49	-0.004	0.000	-0.029	-0.018	-0.019	-0.021	-0.001	-0.003	0.013	0.011
10	1.18	17.73	-0.006	0.001	-0.032	-0.019	-0.020	-0.023	-0.001	-0.004	0.014	0.012
11	1.33	20.00	-0.007	0.003	-0.037	-0.021	-0.021	-0.026	0.001	-0.006	0.015	0.013
12	1.45	21.76	-0.010	0.004	-0.043	-0.023	-0.020	-0.032	0.004	-0.011	0.018	0.015
13	1.60	24.03	-0.014	0.005	-0.050	-0.024	-0.021	-0.037	0.005	-0.013	0.021	0.017
14	1.71	25.64	-0.018	0.006	-0.057	-0.025	-0.023	-0.048	0.005	-0.021	0.024	0.022
15	1.85	27.77	-0.023	0.007	-0.067	-0.028	-0.024	-0.053	0.006	-0.023	0.028	0.024
16	2.03	30.48	-0.034	0.002	-0.083	-0.035	-0.031	-0.066	0.002	-0.033	0.038	0.032
17	2.13	32.02	-0.041	-0.003	-0.093	-0.042	-0.036	-0.075	-0.001	-0.040	0.045	0.038
18	2.24	33.63	-0.052	-0.009	-0.106	-0.051	-0.042	-0.085	-0.004	-0.048	0.055	0.045
19	2.32	34.73	-0.086	-0.042	-0.143	-0.086	-0.055	-0.105	-0.012	-0.063	0.089	0.059
20	2.32	34.87	-0.117	-0.074	-0.176	-0.120	-0.075	-0.128	-0.028	-0.085	0.122	0.079
21	2.34	35.17	-0.150	-0.108	-0.210	-0.155	-0.100	-0.157	-0.050	-0.111	0.156	0.104
22	2.36	35.39	-0.206	-0.165	-0.266	-0.211	-0.145	-0.202	-0.090	-0.156	0.212	0.148
23	2.34	35.09	-0.256	-0.214	-0.316	-0.259	-0.189	-0.248	-0.133	-0.200	0.261	0.192
24	2.31	34.58	-0.357	-0.317	-0.418	-0.362	-0.295	-0.351	-0.236	-0.303	0.364	0.296
25	2.29	34.29	-0.453	-0.412	-0.515	-0.458	-0.395	-0.450	-0.336	-0.401	0.459	0.396
26	2.36	35.38	-0.646	-0.603	-0.713	-0.655	-0.599	-0.651	-0.534	-0.598	0.654	0.595
27	2.22	33.26	-0.790	-0.751	-0.852	-0.795	-0.696	-0.750	-0.627	-0.694	0.797	0.692

Table C-49

TENSION TESTS ON BOLTED CONNECTIONS

SUMMARY SHEET

Test No: 50

Date: April 5, 1995

Test Designation: 1/4x3/4x1

Recorder: Burak Karsu

GEOMETRIC AND MATERIAL PROPERTIES

BOLT

Type: A325

Diameter $d_b=1.0$ in.

Length $L_b=2.5$

Shear Str. $F_v=72$ ksi

Edge Dist. $e=2.0$ in.

Fully Pretensioned--Yes

Bolt Hole Fabr.--Drilled

Bolt Hole Type--Standard

Threads in Shear Plane--X

PLATES

No	Designation	Length (in.)	Width (in.)	Thickness (in.)	Hole Dia. (in.)	Fy (ksi)	Fu (ksi)
Plate 1	PL-41	24.0	4.0	0.25	17/16	46.1	66.2
Plate 2	PL-28	24.0	4.0	0.75	17/16	44.8	69.0

TEST RESULTS

Failure Type: Splitting

Failure Load: 37000 lbs/plate

Max Deflection $\Delta_{max}=0.76$ in.

Failure Plate: PL-41

COMMENTS

- * PL-41 yielded at 0.038 in. of deformation with 28500 lbs of load.
- * Bulging started at 34000 lbs (0.11 in. of deformation).
- * Bolt hole stretched excessively at 0.5 in. of deformation.
- * At 0.9 in. splitting occurred.

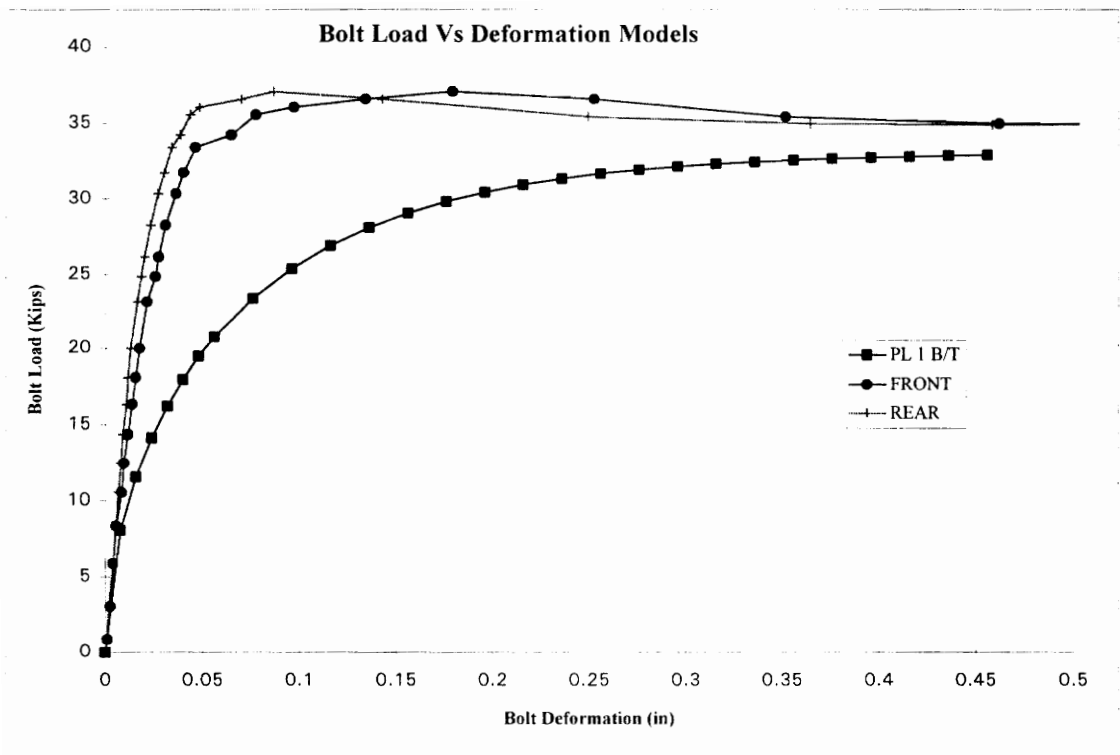

Figure C-50

Plate			Bolt		
	tp	Fu	B/T	Bolt Dia.	A325
Plate 1	0.25	66.2	33.10	Fv	72
Plate 2	0.75	69	103.50	Bolt Shear	56.55

Richard Coefficients

$K = 0$ $K_p = 0$ $R_o = 0$
 $K_1 = 0$ $n = 0$

Data Point	Volts	Load	F1	F2	F3	F4	R1	R2	R3	R4	AVG(F)	AVG(R)
1	0.06	0.87	0.000	0.000	-0.002	-0.002	-0.001	-0.001	-0.001	0.000	0.001	0.001
2	0.20	3.01	0.000	0.000	-0.006	-0.005	-0.002	-0.004	-0.001	0.000	0.003	0.002
3	0.39	5.87	0.000	0.000	-0.009	-0.008	-0.007	-0.009	-0.001	0.000	0.004	0.004
4	0.56	8.37	-0.001	0.000	-0.012	-0.011	-0.010	-0.013	-0.001	0.001	0.006	0.006
5	0.70	10.56	-0.001	0.002	-0.018	-0.017	-0.011	-0.017	-0.001	0.001	0.009	0.007
6	0.83	12.47	-0.001	0.002	-0.021	-0.018	-0.012	-0.021	-0.001	0.001	0.010	0.008
7	0.96	14.37	-0.002	0.003	-0.026	-0.021	-0.013	-0.023	-0.001	-0.001	0.012	0.009
8	1.09	16.35	-0.004	0.004	-0.031	-0.024	-0.015	-0.026	0.000	-0.002	0.014	0.011
9	1.21	18.11	-0.006	0.005	-0.035	-0.026	-0.015	-0.029	0.001	-0.003	0.016	0.012
10	1.33	20.00	-0.009	0.006	-0.040	-0.028	-0.017	-0.032	0.001	-0.004	0.018	0.013
11	1.54	23.16	-0.014	0.009	-0.050	-0.031	-0.020	-0.041	0.003	-0.007	0.021	0.016
12	1.66	24.86	-0.020	0.009	-0.058	-0.033	-0.021	-0.046	0.004	-0.010	0.026	0.018
13	1.74	26.17	-0.022	0.009	-0.062	-0.035	-0.023	-0.049	0.004	-0.012	0.027	0.020
14	1.89	28.29	-0.026	0.009	-0.069	-0.038	-0.026	-0.056	0.004	-0.015	0.031	0.023
15	2.02	30.35	-0.032	0.009	-0.078	-0.043	-0.030	-0.063	0.004	-0.019	0.036	0.027
16	2.12	31.74	-0.037	0.007	-0.084	-0.047	-0.033	-0.068	0.002	-0.021	0.040	0.030
17	2.23	33.43	-0.042	0.004	-0.093	-0.054	-0.037	-0.075	0.001	-0.024	0.046	0.034
18	2.28	34.23	-0.061	-0.013	-0.112	-0.072	-0.042	-0.083	-0.001	-0.029	0.065	0.039
19	2.37	35.55	-0.073	-0.026	-0.125	-0.086	-0.047	-0.090	-0.004	-0.034	0.077	0.044
20	2.40	36.06	-0.092	-0.045	-0.146	-0.105	-0.053	-0.097	-0.007	-0.038	0.097	0.048
21	2.44	36.58	-0.130	-0.081	-0.184	-0.141	-0.076	-0.120	-0.025	-0.058	0.134	0.070
22	2.47	37.09	-0.176	-0.128	-0.226	-0.186	-0.094	-0.141	-0.038	-0.073	0.179	0.087
23	2.44	36.58	-0.249	-0.202	-0.299	-0.260	-0.149	-0.202	-0.090	-0.130	0.253	0.143
24	2.36	35.40	-0.349	-0.301	-0.399	-0.360	-0.256	-0.308	-0.200	-0.235	0.352	0.250
25	2.33	34.96	-0.457	-0.410	-0.510	-0.471	-0.369	-0.423	-0.315	-0.352	0.462	0.365
26	2.33	34.89	-0.552	-0.506	-0.604	-0.567	-0.464	-0.517	-0.409	-0.444	0.557	0.459
27	2.33	34.96	-0.661	-0.614	-0.714	-0.677	-0.574	-0.628	-0.520	-0.555	0.666	0.569
28	2.35	35.18	-0.749	-0.704	-0.803	-0.768	-0.666	-0.719	-0.608	-0.644	0.756	0.659

Table C-50

TENSION TESTS ON BOLTED CONNECTIONS

SUMMARY SHEET

Test No: 51

Date: April 5, 1995

Test Designation: 1/4x1x1

Recorder: Burak Karsu

GEOMETRIC AND MATERIAL PROPERTIES

BOLT

Type:A325 Diameter $d_b=1.0$ in. Length $L_b=2.75$ in.

Shear Str. $F_v=72$ ksi Edge Dist. $e=2.0$ in. Fully Pretensioned--Yes

Bolt Hole Fabr.--Drilled Bolt Hole Type--Standard

Threads in Shear Plane--X

PLATES

No	Designation	Length (in.)	Width (in.)	Thickness (in.)	Hole Dia. (in.)	Fy (ksi)	Fu (ksi)
Plate 1	PL-41	24.0	4.0	0.25	17/16	46.1	66.2
Plate 2	PL-30	24.0	4.0	1.0	17/16	40.4	66.3

TEST RESULTS

Failure Type: Splitting

Failure Load: 36000 lbs/plate

Max Deflection $\Delta_{max}=0.85$ in.

Failure Plate: PL-41

COMMENTS

* PL-41 yielded at 28300 lbs with a deformation of 0.035 in.

* Bulging started at 0.18 of deformation on PL-41.

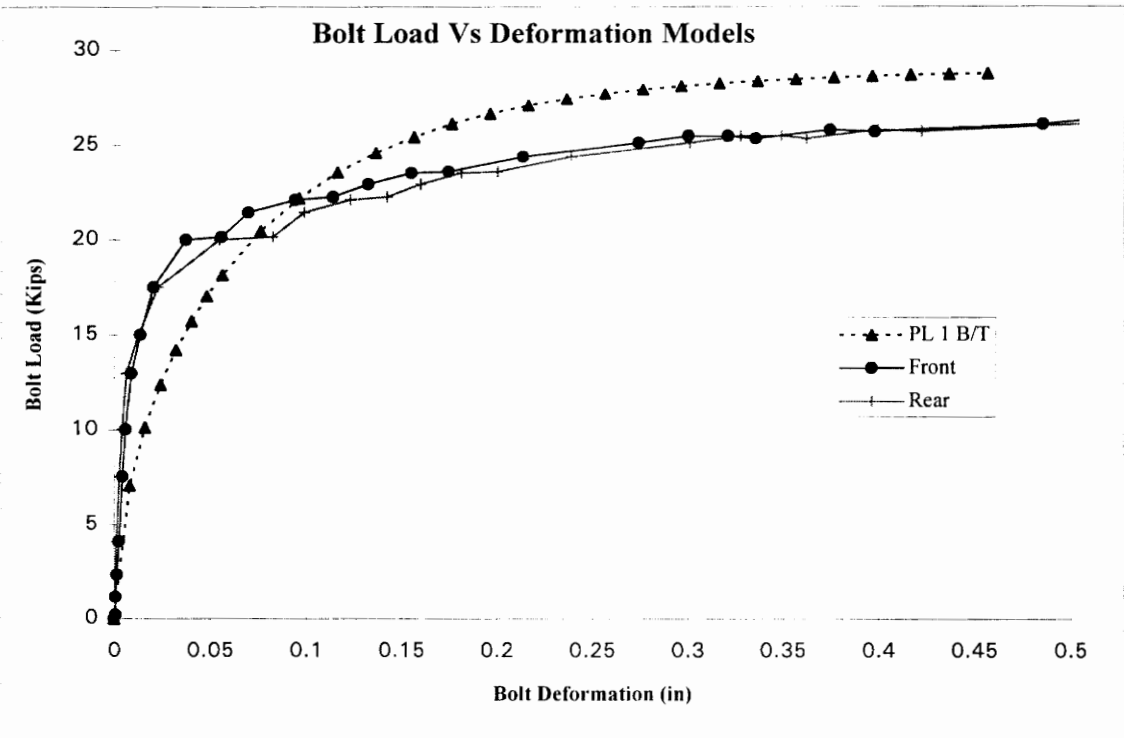

Figure C-51

Plate				Bolt		
	tp	Fu	B/T	Bolt Dia.	A325	
Plate 1	0.25	66.2	28.963	Fv	72	
Plate 2	1	66.3	116.03	Bolt Shear	43.29	

Richard Coefficients

K = 0 Kp = 0 Ro = 0
 K1 = 0 n = 0

Data Point	Volts	Load	F1	F2	F3	F4	R1	R2	R3	R4	AVG(F)	AVG(R)
1	0.08	1.17	-0.001	0.000	-0.002	-0.001	-0.002	-0.002	0.000	0.000	0.001	0.001
2	0.22	3.37	-0.001	0.000	-0.004	-0.004	-0.005	-0.004	0.000	0.000	0.002	0.002
3	0.36	5.42	-0.001	0.000	-0.007	-0.006	-0.008	-0.007	-0.001	0.001	0.003	0.004
4	0.50	7.47	-0.001	0.000	-0.009	-0.008	-0.010	-0.009	-0.001	0.001	0.004	0.005
5	0.67	10.03	-0.002	0.000	-0.012	-0.011	-0.014	-0.013	-0.001	0.001	0.006	0.007
6	0.80	12.01	-0.002	0.000	-0.014	-0.013	-0.017	-0.016	0.000	0.001	0.007	0.008
7	0.95	14.28	-0.003	0.000	-0.017	-0.014	-0.020	-0.020	0.000	0.001	0.009	0.010
8	1.05	15.76	-0.004	-0.001	-0.020	-0.016	-0.023	-0.022	0.000	0.001	0.010	0.011
9	1.17	17.59	-0.004	0.000	-0.023	-0.019	-0.024	-0.024	0.000	0.001	0.012	0.012
10	1.26	18.91	-0.004	-0.001	-0.026	-0.020	-0.025	-0.026	0.001	-0.001	0.013	0.013
11	1.36	20.37	-0.006	0.000	-0.029	-0.023	-0.027	-0.028	0.001	-0.001	0.014	0.014
12	1.48	22.13	-0.007	-0.001	-0.032	-0.025	-0.029	-0.031	0.001	-0.001	0.016	0.015
13	1.56	23.45	-0.015	-0.008	-0.045	-0.032	-0.032	-0.032	-0.001	-0.002	0.025	0.017
14	1.67	24.98	-0.016	-0.008	-0.047	-0.034	-0.033	-0.035	-0.001	-0.002	0.026	0.018
15	1.80	27.04	-0.023	-0.015	-0.057	-0.043	-0.036	-0.040	0.000	-0.004	0.034	0.020
16	1.89	28.28	-0.023	-0.015	-0.059	-0.046	-0.037	-0.043	0.000	-0.005	0.036	0.021
17	1.92	28.79	-0.028	-0.022	-0.069	-0.053	-0.045	-0.052	-0.006	-0.013	0.043	0.029
18	2.05	30.77	-0.035	-0.029	-0.078	-0.063	-0.048	-0.056	-0.006	-0.014	0.051	0.031
19	2.11	31.58	-0.063	-0.058	-0.105	-0.092	-0.056	-0.065	-0.009	-0.019	0.080	0.037
20	2.15	32.24	-0.082	-0.078	-0.126	-0.111	-0.058	-0.067	-0.009	-0.020	0.099	0.039
21	2.24	33.56	-0.111	-0.106	-0.155	-0.140	-0.067	-0.076	-0.012	-0.025	0.128	0.045
22	2.29	34.30	-0.139	-0.135	-0.183	-0.169	-0.084	-0.092	-0.023	-0.036	0.157	0.059
23	2.28	34.22	-0.139	-0.135	-0.183	-0.169	-0.084	-0.092	-0.024	-0.036	0.157	0.059
24	2.26	33.93	-0.172	-0.169	-0.219	-0.204	-0.128	-0.135	-0.066	-0.077	0.191	0.101
25	2.26	33.93	-0.212	-0.210	-0.260	-0.245	-0.173	-0.179	-0.111	-0.123	0.232	0.146
26	2.23	33.42	-0.304	-0.301	-0.352	-0.337	-0.269	-0.274	-0.206	-0.217	0.323	0.242
27	2.18	32.68	-0.389	-0.387	-0.441	-0.425	-0.356	-0.362	-0.293	-0.305	0.411	0.329
28	2.27	34.00	-0.526	-0.524	-0.579	-0.559	-0.495	-0.499	-0.428	-0.439	0.547	0.465
29	2.35	35.32	-0.645	-0.640	-0.699	-0.680	-0.618	-0.619	-0.549	-0.558	0.666	0.586
30	2.36	35.47	-0.727	-0.725	-0.785	-0.763	-0.708	-0.709	-0.637	-0.646	0.750	0.675
31	2.40	36.05	-0.824	-0.823	-0.883	-0.863	-0.807	-0.808	-0.736	-0.743	0.848	0.774

Table C-51

TENSION TESTS ON BOLTED CONNECTIONS

SUMMARY SHEET

Test No: 52

Date: April 5, 1995

Test Designation: 3/8x3/8x1

Recorder: Burak Karsu

GEOMETRIC AND MATERIAL PROPERTIES

BOLT

Type: A325 Diameter $d_b=1.0$ in. Length $L_b=2.5$ in.

Shear Str. $F_v=72$ ksi Edge Dist. $e=2.0$ in. Fully Pretensioned--Yes

Bolt Hole Fabr.--Drilled

Bolt Hole Type--Standard

Threads in Shear Plane--X

PLATES

No	Designation	Length (in.)	Width (in.)	Thickness (in.)	Hole Dia. (in.)	Fy (ksi)	Fu (ksi)
Plate 1	PL-24	24.0	4.0	0.375	17/16	43.3	63.6
Plate 2	PL-24	24.0	4.0	0.375	17/16	43.3	63.6

TEST RESULTS

Failure Type: Bearing/ Tear Out

Failure Load: 52000 lbs/plate

Max Deflection $\Delta_{max}=1.5$ in.

Failure Plate: PL-24

COMMENTS

- * At 35000 lbs, PL-24 yielded with a deformation of 0.05 in.
- * At 36000 lbs, tips of the plates started curling back.
- * Bulging started at 39000 lbs with a deformation of 0.2 in.
- * Connection gained strength in the plastic region.

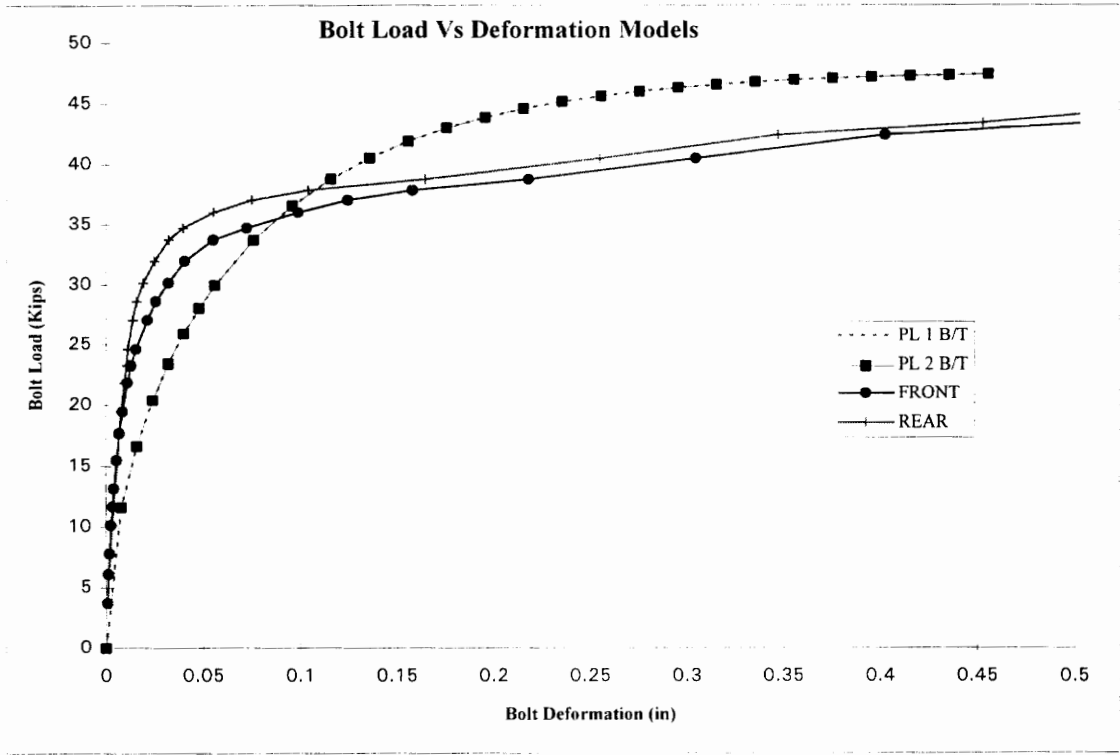

Figure C-52

Plate	tp	Fu	B/T	Bolt	A325
Plate 1	0.375	63.6	47.70	Bolt Dia.	1
Plate 2	0.375	63.6	47.70	Fv	72
				Bolt Shear	56.55

Richard Coefficients

K= 0 Kp= 0 Ro= 0
 K1= 0 n= 0

Data Point	Volts	Load	F1	F2	F3	F4	R1	R2	R3	R4	AVG(F)	AVG(R)
1	0.17	3.72	-0.001	-0.001	-0.001	-0.001	-0.001	-0.001	-0.001	0.000	0.001	0.001
2	0.33	6.14	-0.002	-0.001	-0.001	-0.001	-0.002	-0.002	-0.001	-0.001	0.001	0.002
3	0.44	7.82	-0.002	-0.002	-0.002	-0.002	-0.003	-0.003	-0.002	-0.001	0.002	0.002
4	0.60	10.17	-0.003	-0.003	-0.002	-0.002	-0.004	-0.005	-0.003	-0.001	0.003	0.003
5	0.70	11.71	-0.004	-0.004	-0.004	-0.003	-0.005	-0.006	-0.004	-0.002	0.004	0.004
6	0.80	13.17	-0.004	-0.004	-0.004	-0.004	-0.006	-0.006	-0.005	-0.002	0.004	0.005
7	0.96	15.51	-0.006	-0.006	-0.006	-0.004	-0.009	-0.006	-0.007	-0.002	0.006	0.006
8	1.10	17.71	-0.009	-0.007	-0.007	-0.006	-0.010	-0.006	-0.010	-0.002	0.007	0.007
9	1.22	19.47	-0.010	-0.008	-0.010	-0.006	-0.012	-0.006	-0.012	-0.002	0.009	0.008
10	1.38	21.90	-0.013	-0.009	-0.014	-0.008	-0.014	-0.007	-0.015	-0.002	0.011	0.009
11	1.48	23.28	-0.015	-0.011	-0.015	-0.010	-0.016	-0.007	-0.016	-0.003	0.013	0.011
12	1.56	24.61	-0.017	-0.013	-0.018	-0.013	-0.017	-0.008	-0.017	-0.003	0.015	0.011
13	1.73	27.10	-0.022	-0.023	-0.023	-0.018	-0.021	-0.010	-0.020	-0.005	0.021	0.014
14	1.83	28.63	-0.026	-0.028	-0.026	-0.023	-0.024	-0.011	-0.023	-0.006	0.026	0.016
15	1.93	30.17	-0.031	-0.035	-0.031	-0.031	-0.029	-0.013	-0.028	-0.007	0.032	0.019
16	2.06	32.00	-0.038	-0.048	-0.037	-0.040	-0.035	-0.017	-0.036	-0.012	0.041	0.025
17	2.17	33.76	-0.050	-0.065	-0.049	-0.057	-0.044	-0.022	-0.046	-0.018	0.055	0.032
18	2.24	34.71	-0.065	-0.084	-0.065	-0.076	-0.053	-0.028	-0.054	-0.024	0.072	0.040
19	2.33	36.03	-0.091	-0.112	-0.089	-0.104	-0.071	-0.042	-0.070	-0.037	0.099	0.055
20	2.39	37.06	-0.116	-0.139	-0.115	-0.130	-0.094	-0.062	-0.090	-0.054	0.125	0.075
21	2.45	37.87	-0.149	-0.172	-0.149	-0.163	-0.124	-0.089	-0.121	-0.083	0.158	0.104
22	2.51	38.77	-0.209	-0.232	-0.210	-0.224	-0.186	-0.148	-0.182	-0.142	0.219	0.165
23	2.62	40.50	-0.295	-0.318	-0.297	-0.311	-0.280	-0.237	-0.276	-0.229	0.305	0.255
24	2.75	42.41	-0.391	-0.417	-0.396	-0.408	-0.374	-0.328	-0.370	-0.318	0.403	0.348
25	2.82	43.43	-0.496	-0.524	-0.503	-0.517	-0.484	-0.432	-0.476	-0.421	0.510	0.453
26	2.91	44.76	-0.590	-0.620	-0.600	-0.611	-0.583	-0.525	-0.575	-0.513	0.605	0.549
27	2.95	45.34	-0.684	-0.720	-0.695	-0.712	-0.638	-0.578	-0.622	-0.566	0.703	0.601
28	2.99	46.07	-0.779	-0.817	-0.793	-0.808	-0.735	-0.673	-0.721	-0.661	0.799	0.697
29	3.07	47.25	-0.898	-0.935	-0.910	-0.926	-0.852	-0.786	-0.839	-0.775	0.917	0.813
30	3.12	47.98	-0.985	-1.027	-1.003	-1.018	-0.943	-0.876	-0.934	-0.867	1.008	0.905
31	3.23	49.66	-1.139	-1.184	-1.162	-1.177	-1.096	-1.020	-1.083	-1.010	1.165	1.052
32	3.24	49.74	-1.194	-1.240	-1.218	-1.232	-1.152	-1.076	-1.141	-1.067	1.221	1.109
33	3.28	50.32	-1.281	-1.326	-1.303	-1.319	-1.236	-1.156	-1.226	-1.151	1.307	1.192
34	3.28	50.32	-1.386	-1.434	-1.413	-1.426	-1.343	-1.256	-1.331	-1.252	1.415	1.296
35	3.39	51.93	-1.535	-1.464	-1.420	-1.550	-1.491	-1.256	-1.479	-1.400	1.492	1.406
36	3.40	52.08	-1.583	-1.464	-1.423	-1.550	-1.559	-1.256	-1.545	-1.462	1.505	1.456

Table C-52

TENSION TESTS ON BOLTED CONNECTIONS

SUMMARY SHEET

Test No: 53

Date: April 6, 1995

Test Designation: 3/8x1/2x1

Recorder: Burak Karsu

GEOMETRIC AND MATERIAL PROPERTIES

BOLT

Type:A325

Diameter $d_b=1.0$ in.

Length $L_b= 2.5$ in.

Shear Str. $F_v=72$ ksi

Edge Dist. $e=2.0$ in.

Fully Pretensioned--Yes

Bolt Hole Fabr.--Drilled

Bolt Hole Type--Standard

Threads in Shear Plane--X

PLATES

<u>No</u>	<u>Designation</u>	<u>Length (in.)</u>	<u>Width (in.)</u>	<u>Thickness (in.)</u>	<u>Hole Dia. (in.)</u>	<u>Fy (ksi)</u>	<u>Fu (ksi)</u>
Plate 1	PL-24	24.0	4.0	0.375	17/16	43.3	63.6
Plate 2	PL-12	24.0	4.0	0.50	17/16	51.5	74.5

TEST RESULTS

Failure Type: Bearing/ Tear Out

Failure Load: 54100 lbs/plate

Max Deflection $\Delta_{max}=1.1$ in.

Failure Plate: PL-24

COMMENTS

* PL-24 started yielding at 36000 lbs with a deformation of 0.06 in

* At 43500 lbs, PL-12 yielded with a deformation of 0.11 in.

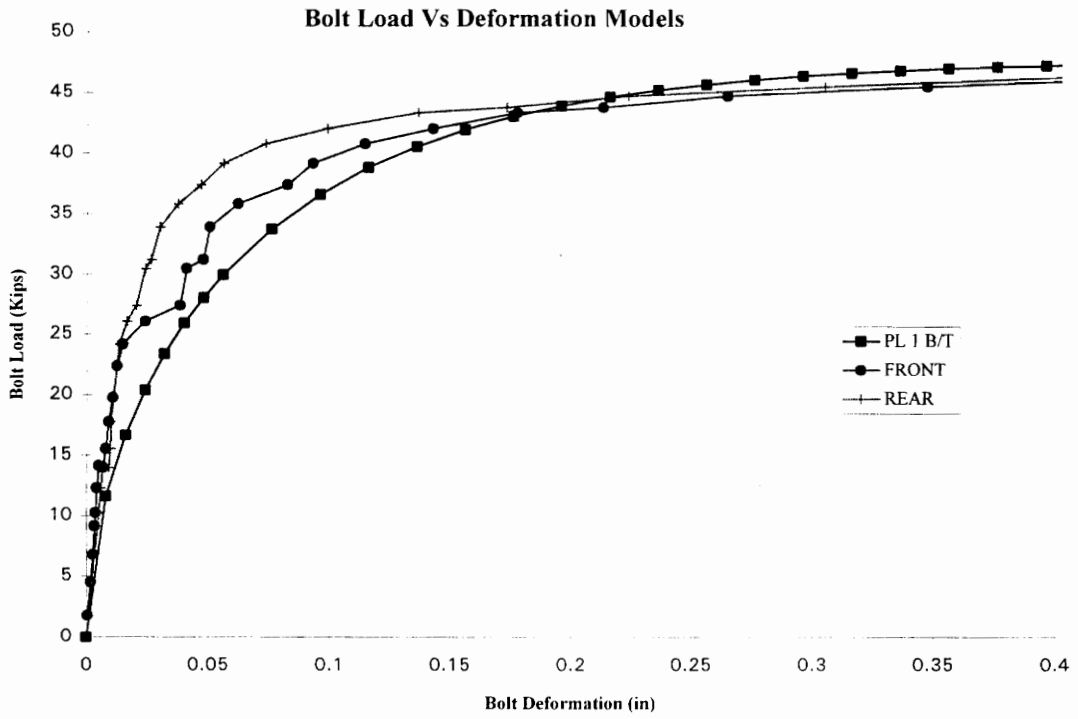

Figure C-53

Plate			Bolt		
	tp	Fu	B/T	Bolt Dia.	A325
Plate 1	0.375	63.6	47.70	Fv	72
Plate 2	0.5	74.5	74.50	Bolt Shear	56.55

Richard Coefficients

$K = 0$ $K_p = 0$ $R_o = 0$
 $K_1 = 0$ $n = 0$

Data Point	Volts	Load	F1	F2	F3	F4	R1	R2	R3	R4	AVG(F)	AVG(R)
1	0.12	1.83	-0.001	0.000	-0.001	-0.001	-0.002	-0.001	-0.001	0.000	0.000	0.001
2	0.30	4.54	-0.001	-0.001	-0.002	-0.003	-0.004	-0.003	-0.001	-0.001	0.002	0.002
3	0.45	6.81	-0.001	-0.001	-0.004	-0.004	-0.005	-0.005	-0.001	-0.001	0.003	0.003
4	0.61	9.16	-0.001	-0.001	-0.006	-0.006	-0.007	-0.007	-0.001	-0.003	0.003	0.005
5	0.68	10.26	-0.001	-0.001	-0.006	-0.006	-0.008	-0.007	-0.002	-0.003	0.004	0.005
6	0.82	12.31	-0.002	-0.001	-0.007	-0.007	-0.010	-0.009	-0.002	-0.003	0.004	0.006
7	0.94	14.14	-0.002	-0.002	-0.008	-0.009	-0.011	-0.010	-0.002	-0.004	0.005	0.007
8	0.93	14.00	-0.004	-0.002	-0.010	-0.011	-0.010	-0.012	-0.012	-0.003	0.007	0.009
9	1.04	15.54	-0.004	-0.003	-0.012	-0.013	-0.011	-0.013	-0.012	-0.004	0.008	0.010
10	1.19	17.81	-0.005	-0.004	-0.013	-0.015	-0.012	-0.013	-0.012	-0.004	0.009	0.010
11	1.32	19.78	-0.006	-0.005	-0.016	-0.017	-0.013	-0.015	-0.012	-0.004	0.011	0.011
12	1.49	22.42	-0.007	-0.006	-0.018	-0.020	-0.015	-0.017	-0.012	-0.006	0.013	0.012
13	1.61	24.18	-0.007	-0.007	-0.021	-0.023	-0.016	-0.018	-0.013	-0.007	0.015	0.013
14	1.74	26.08	-0.015	-0.017	-0.032	-0.032	-0.018	-0.024	-0.016	-0.009	0.024	0.017
15	1.83	27.40	-0.028	-0.031	-0.045	-0.050	-0.019	-0.031	-0.019	-0.012	0.038	0.020
16	2.03	30.48	-0.029	-0.032	-0.049	-0.054	-0.021	-0.037	-0.021	-0.017	0.041	0.024
17	2.08	31.21	-0.034	-0.039	-0.056	-0.062	-0.023	-0.040	-0.024	-0.019	0.048	0.026
18	2.08	31.21	-0.034	-0.040	-0.056	-0.062	-0.023	-0.040	-0.024	-0.019	0.048	0.026
19	2.26	33.92	-0.035	-0.042	-0.059	-0.067	-0.026	-0.046	-0.026	-0.023	0.051	0.030
20	2.39	35.82	-0.043	-0.054	-0.070	-0.080	-0.033	-0.056	-0.031	-0.030	0.062	0.037
21	2.49	37.36	-0.062	-0.075	-0.091	-0.102	-0.043	-0.067	-0.039	-0.038	0.083	0.047
22	2.61	39.12	-0.072	-0.085	-0.102	-0.113	-0.053	-0.078	-0.047	-0.046	0.093	0.056
23	2.72	40.74	-0.095	-0.106	-0.123	-0.134	-0.071	-0.096	-0.063	-0.063	0.115	0.073
24	2.80	41.98	-0.123	-0.135	-0.152	-0.161	-0.097	-0.122	-0.089	-0.088	0.143	0.099
25	2.89	43.30	-0.158	-0.169	-0.188	-0.195	-0.136	-0.159	-0.127	-0.125	0.178	0.137
26	2.92	43.74	-0.194	-0.206	-0.223	-0.230	-0.173	-0.195	-0.163	-0.162	0.213	0.173
27	2.98	44.69	-0.246	-0.256	-0.275	-0.282	-0.224	-0.246	-0.213	-0.211	0.265	0.224
28	3.03	45.43	-0.326	-0.338	-0.358	-0.367	-0.304	-0.331	-0.293	-0.292	0.347	0.305
29	3.09	46.31	-0.430	-0.444	-0.464	-0.473	-0.412	-0.440	-0.400	-0.399	0.453	0.413
30	3.15	47.26	-0.524	-0.540	-0.561	-0.570	-0.510	-0.539	-0.496	-0.495	0.549	0.510
31	3.26	48.87	-0.620	-0.635	-0.658	-0.668	-0.607	-0.640	-0.593	-0.595	0.645	0.609
32	3.34	50.12	-0.714	-0.730	-0.752	-0.763	-0.708	-0.742	-0.691	-0.693	0.740	0.709
33	3.41	51.21	-0.805	-0.822	-0.843	-0.854	-0.806	-0.842	-0.790	-0.793	0.831	0.808
34	3.47	52.09	-0.895	-0.913	-0.932	-0.944	-0.904	-0.942	-0.888	-0.890	0.921	0.906
35	3.51	52.60	-0.987	-1.003	-1.022	-1.034	-1.002	-1.042	-0.987	-0.988	1.011	1.005
36	3.61	54.14	-1.076	-1.095	-1.111	-1.124	-1.104	-1.142	-1.088	-1.090	1.101	1.106

Table C-53

TENSION TESTS ON BOLTED CONNECTIONS

SUMMARY SHEET

Test No: 54

Date: April 6, 1995

Test Designation: 3/8x5/8x1

Recorder: Burak Karsu

GEOMETRIC AND MATERIAL PROPERTIES

BOLT

Type:A325

Diameter $d_b=1.0$ in.

Length $L_b= 2.5$ in.

Shear Str. $F_v=72$ ksi

Edge Dist. $e=2.0$ in.

Fully Pretensioned--Yes

Bolt Hole Fabr.--Drilled

Bolt Hole Type--Standard

Threads in Shear Plane--X

PLATES

No	Designation	Length (in.)	Width (in.)	Thickness (in.)	Hole Dia. (in.)	Fy (ksi)	Fu (ksi)
Plate 1	PL-24	24.0	4.0	0.375	17/16	43.3	63.6
Plate 2	PL-27a	24.0	4.0	0.625	17/16	45.4	68.4

TEST RESULTS

Failure Type: Splitting

Failure Load: 51700 lbs/plate

Max Deflection $\Delta_{max}=0.9$ in.

Failure Plate: PL-24

COMMENTS

- * At 35000 lbs, PL-24 yielded with a deformation of 0.04 in.
- * Bulging on PL-24 started at 0.15 in of deformation.
- * At 0.88 in. of deformation, splitting occurred on PL-24.
- * The connection gained strength.

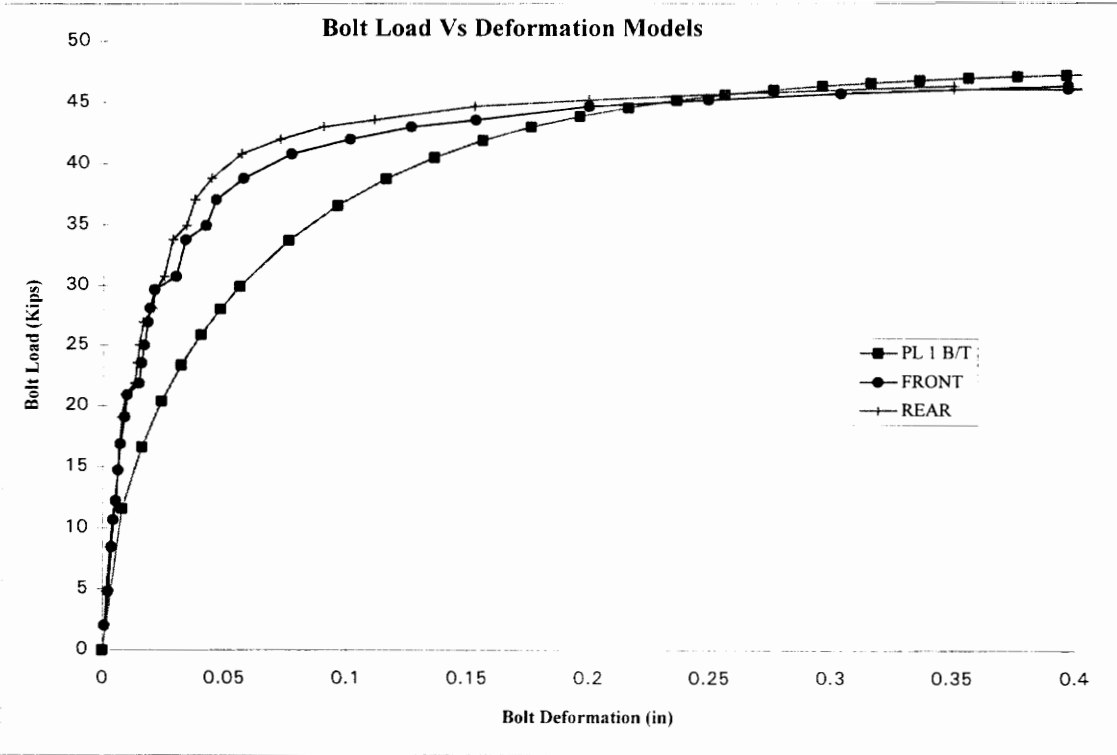

Figure C-54

Plate	tp	Fu	B/T	Bolt	A325
Plate 1	0.375	63.6	47.70	Bolt Dia.	1
Plate 2	0.625	68.4	85.50	Fv	72
				Bolt Shear	56.55

Richard Coefficients

K= 0 Kp= 0 Ro= 0
 K1= 0 n= 0

Data Point	Volts	Load	F1	F2	F3	F4	R1	R2	R3	R4	AVG(F)	AVG(R)
1	0.12	2.04	0.000	0.000	-0.001	-0.002	-0.002	-0.001	0.000	0.000	0.001	0.001
2	0.31	4.81	-0.001	0.000	-0.004	-0.004	-0.004	-0.002	0.000	0.000	0.002	0.002
3	0.55	8.49	-0.001	0.000	-0.007	-0.007	-0.006	-0.005	-0.001	0.000	0.004	0.003
4	0.70	10.68	-0.001	0.000	-0.009	-0.008	-0.008	-0.007	-0.001	-0.001	0.004	0.004
5	0.81	12.29	-0.001	-0.001	-0.010	-0.010	-0.010	-0.009	-0.001	-0.001	0.006	0.005
6	0.97	14.71	-0.001	-0.001	-0.012	-0.012	-0.012	-0.010	-0.002	-0.001	0.006	0.006
7	1.11	16.91	-0.002	-0.001	-0.013	-0.013	-0.014	-0.011	-0.002	-0.001	0.007	0.007
8	1.26	19.11	-0.002	-0.001	-0.017	-0.016	-0.016	-0.013	-0.002	-0.001	0.009	0.008
9	1.38	20.94	-0.003	-0.001	-0.019	-0.017	-0.018	-0.016	-0.002	-0.001	0.010	0.009
10	1.45	21.89	-0.006	-0.004	-0.028	-0.021	-0.019	-0.017	-0.007	-0.009	0.015	0.013
11	1.56	23.57	-0.005	-0.004	-0.031	-0.023	-0.020	-0.019	-0.007	-0.009	0.016	0.014
12	1.66	25.05	-0.006	-0.005	-0.032	-0.024	-0.021	-0.021	-0.007	-0.010	0.017	0.015
13	1.78	26.95	-0.007	-0.005	-0.035	-0.026	-0.022	-0.024	-0.007	-0.012	0.018	0.016
14	1.86	28.12	-0.007	-0.006	-0.037	-0.028	-0.026	-0.029	-0.009	-0.017	0.019	0.020
15	1.96	29.66	-0.009	-0.006	-0.040	-0.029	-0.027	-0.031	-0.010	-0.018	0.021	0.021
16	2.04	30.76	-0.016	-0.012	-0.053	-0.038	-0.031	-0.037	-0.012	-0.021	0.030	0.025
17	2.24	33.76	-0.017	-0.014	-0.060	-0.043	-0.035	-0.042	-0.012	-0.024	0.034	0.028
18	2.32	34.94	-0.024	-0.021	-0.070	-0.053	-0.042	-0.050	-0.016	-0.029	0.042	0.034
19	2.46	37.06	-0.027	-0.023	-0.076	-0.059	-0.046	-0.054	-0.018	-0.031	0.046	0.037
20	2.57	38.82	-0.037	-0.031	-0.090	-0.072	-0.055	-0.063	-0.022	-0.037	0.057	0.044
21	2.71	40.80	-0.055	-0.049	-0.111	-0.093	-0.070	-0.078	-0.031	-0.047	0.077	0.057
22	2.79	41.98	-0.078	-0.072	-0.138	-0.117	-0.087	-0.096	-0.046	-0.061	0.101	0.072
23	2.85	43.00	-0.102	-0.097	-0.163	-0.144	-0.105	-0.116	-0.062	-0.078	0.126	0.090
24	2.89	43.59	-0.127	-0.124	-0.190	-0.171	-0.127	-0.138	-0.082	-0.097	0.153	0.111
25	2.97	44.69	-0.174	-0.171	-0.238	-0.216	-0.169	-0.180	-0.122	-0.139	0.200	0.153
26	2.97	44.68	-0.175	-0.171	-0.238	-0.216	-0.169	-0.180	-0.122	-0.139	0.200	0.153
27	3.00	45.20	-0.224	-0.219	-0.288	-0.266	-0.217	-0.229	-0.168	-0.186	0.249	0.200
28	3.03	45.71	-0.276	-0.273	-0.343	-0.322	-0.273	-0.286	-0.223	-0.243	0.304	0.256
29	3.07	46.30	-0.369	-0.366	-0.438	-0.414	-0.369	-0.381	-0.317	-0.334	0.397	0.350
30	3.06	46.07	-0.369	-0.366	-0.438	-0.414	-0.369	-0.381	-0.317	-0.334	0.397	0.350
31	3.05	45.93	-0.476	-0.475	-0.549	-0.524	-0.478	-0.490	-0.424	-0.442	0.506	0.458
32	3.23	48.64	-0.587	-0.584	-0.662	-0.636	-0.587	-0.602	-0.532	-0.551	0.617	0.568
33	3.35	50.40	-0.717	-0.716	-0.799	-0.772	-0.725	-0.740	-0.667	-0.685	0.751	0.704
34	3.43	51.72	-0.857	-0.855	-0.941	-0.914	-0.867	-0.882	-0.806	-0.826	0.892	0.845

Table C-54

TENSION TESTS ON BOLTED CONNECTIONS

SUMMARY SHEET

Test No: 55

Date: April 6, 1995

Test Designation: 3/8x3/4x1

Recorder: Burak Karsu

GEOMETRIC AND MATERIAL PROPERTIES

BOLT

Type:A325 Diameter $d_b=1.0$ in. Length $L_b=2.75$ in.

Shear Str. $F_v=72$ ksi Edge Dist. $e=2.0$ in. Fully Pretensioned--Yes

Bolt Hole Fabr.--Drilled Bolt Hole Type--Standard

Threads in Shear Plane--X

PLATES

No	Designation	Length (in.)	Width (in.)	Thickness (in.)	Hole Dia. (in.)	Fy (ksi)	Fu (ksi)
Plate 1	PL-24	24.0	4.0	0.375	17/16	43.3	63.6
Plate 2	PL-28	24.0	4.0	0.75	17/16	44.8	64.0

TEST RESULTS

Failure Type: Splitting

Failure Load: 51700 lbs/plate Max Deflection $\Delta_{max}=0.9$ in.

Failure Plate: PL-24

COMMENTS

- * PL-24 yielded at 35000 lbs with a deformation of 0.04 in.
- * Bulging started at 0.15 in. on PL-24.
- * At 0.8 in., splitting occurred.

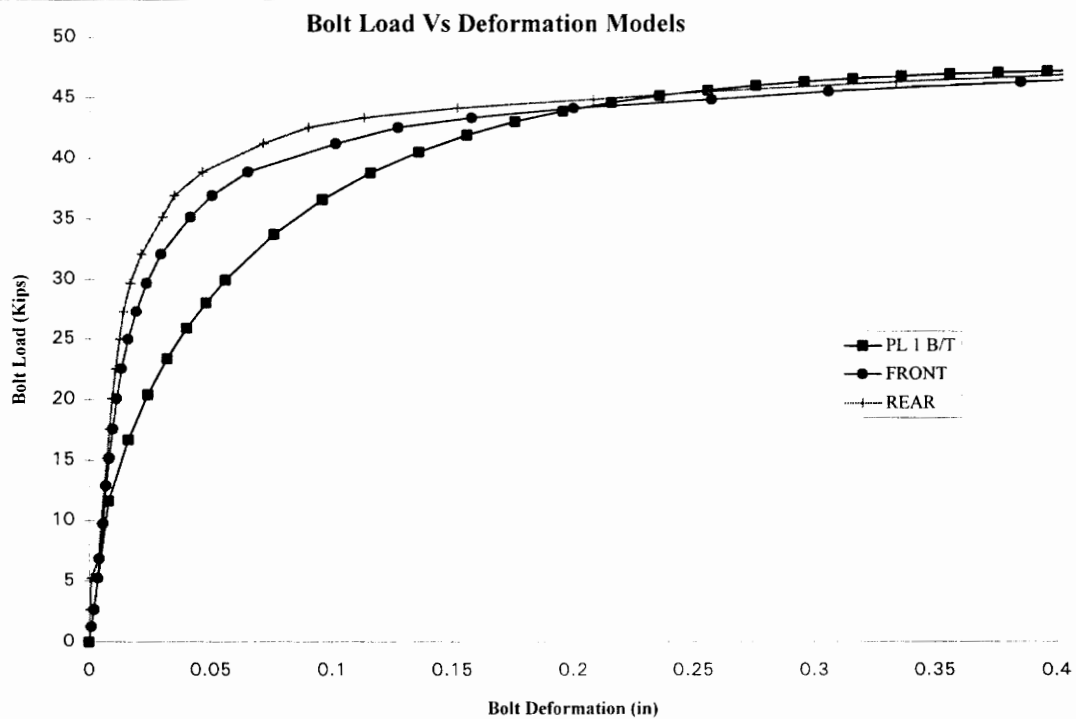

Figure C-55

Plate				Bolt	
	tp	Fu	B/T	Bolt Dia.	A325
Plate 1	0.375	63.6	47.70	Fv	72
Plate 2	0.75	64	96.00	Bolt Shear	56.55

Richard Coefficients

$K = 0$ $K_p = 0$ $R_o = 0$
 $K_1 = 0$ $n = 0$

Data Point	Volts	Load	F1	F2	F3	F4	R1	R2	R3	R4	AVG(F)	AVG(R)
1	0.09	1.32	0.000	0.000	-0.002	-0.002	0.000	-0.001	-0.001	0.000	0.001	0.000
2	0.18	2.71	0.000	0.000	-0.004	-0.004	0.001	-0.001	-0.001	0.000	0.002	0.000
3	0.35	5.27	0.000	0.000	-0.007	-0.007	0.000	-0.001	-0.001	-0.001	0.004	0.001
4	0.46	6.89	0.000	0.000	-0.008	-0.009	0.000	-0.002	-0.012	-0.001	0.004	0.004
5	0.65	9.75	0.000	0.000	-0.011	-0.012	-0.001	-0.004	-0.013	-0.001	0.006	0.005
6	0.86	12.90	0.000	-0.001	-0.013	-0.014	-0.004	-0.006	-0.013	-0.001	0.007	0.006
7	1.01	15.17	0.000	-0.001	-0.015	-0.017	-0.006	-0.009	-0.013	-0.001	0.008	0.007
8	1.17	17.59	0.000	-0.002	-0.017	-0.020	-0.007	-0.011	-0.013	-0.002	0.010	0.008
9	1.34	20.08	-0.001	-0.002	-0.020	-0.023	-0.009	-0.013	-0.013	-0.002	0.011	0.009
10	1.50	22.57	-0.001	-0.003	-0.023	-0.026	-0.011	-0.015	-0.013	-0.003	0.013	0.011
11	1.67	24.99	-0.001	-0.006	-0.025	-0.032	-0.013	-0.018	-0.014	-0.004	0.016	0.012
12	1.82	27.33	-0.002	-0.009	-0.028	-0.038	-0.016	-0.021	-0.015	-0.004	0.019	0.014
13	1.98	29.68	-0.004	-0.013	-0.032	-0.045	-0.020	-0.024	-0.017	-0.006	0.024	0.017
14	2.14	32.10	-0.006	-0.018	-0.039	-0.055	-0.026	-0.031	-0.020	-0.009	0.030	0.021
15	2.34	35.17	-0.012	-0.029	-0.051	-0.074	-0.037	-0.040	-0.028	-0.015	0.042	0.030
16	2.46	36.93	-0.017	-0.038	-0.061	-0.086	-0.044	-0.047	-0.031	-0.018	0.050	0.035
17	2.59	38.86	-0.028	-0.052	-0.076	-0.105	-0.059	-0.061	-0.040	-0.026	0.065	0.046
18	2.75	41.19	-0.059	-0.088	-0.113	-0.147	-0.088	-0.091	-0.061	-0.047	0.102	0.072
19	2.83	42.51	-0.083	-0.114	-0.138	-0.174	-0.109	-0.112	-0.077	-0.063	0.127	0.090
20	2.89	43.31	-0.113	-0.144	-0.168	-0.207	-0.133	-0.137	-0.098	-0.085	0.158	0.113
21	2.94	44.12	-0.153	-0.186	-0.211	-0.251	-0.174	-0.178	-0.135	-0.121	0.200	0.152
22	2.99	44.85	-0.209	-0.242	-0.268	-0.311	-0.232	-0.238	-0.188	-0.175	0.258	0.208
23	3.03	45.51	-0.255	-0.291	-0.317	-0.361	-0.281	-0.287	-0.236	-0.222	0.306	0.257
24	3.09	46.32	-0.333	-0.370	-0.396	-0.442	-0.359	-0.367	-0.311	-0.298	0.385	0.334
25	3.15	47.27	-0.441	-0.481	-0.508	-0.555	-0.473	-0.479	-0.424	-0.408	0.496	0.446
26	3.25	48.81	-0.582	-0.624	-0.652	-0.701	-0.617	-0.625	-0.565	-0.549	0.640	0.589
27	3.35	50.20	-0.691	-0.735	-0.764	-0.815	-0.728	-0.738	-0.674	-0.657	0.751	0.699
28	3.40	50.93	-0.790	-0.836	-0.865	-0.917	-0.826	-0.836	-0.770	-0.752	0.852	0.796
29	3.45	51.74	-0.836	-0.883	-0.912	-0.964	-0.873	-0.882	-0.816	-0.798	0.899	0.842

Table C-55

TENSION TESTS ON BOLTED CONNECTIONS

SUMMARY SHEET

Test No: 56

Date: April 7, 1995

Test Designation: 3/8x1x1

Recorder: Burak Karsu

GEOMETRIC AND MATERIAL PROPERTIES

BOLT

Type:A325

Diameter $d_b=1.0$ in.

Length $L_b= 3.0$ in.

Shear Str. $F_v=72$ ksi

Edge Dist. $e=2.0$ in.

Fully Pretensioned--Yes

Bolt Hole Fabr.--Drilled

Bolt Hole Type--Standard

Threads in Shear Plane--X

PLATES

No	Designation	Length (in.)	Width (in.)	Thickness (in.)	Hole Dia. (in.)	Fy (ksi)	Fu (ksi)
Plate 1	PL-24	24.0	4.0	0.375	17/16	43.3	63.6
Plate 2	PL-31	24.0	4.0	1.0	17/16	42.1	67.8

TEST RESULTS

Failure Type: Splitting

Failure Load: 50500 lbs/plate

Max Deflection $\Delta_{max}=0.88$ in.

Failure Plate: PL-24

COMMENTS

* Yielding on PL-24 started at 0.033 in of deformation with a load of 36500 lbs.

* Cracks appeared on the bulged part at a deformation of 0.98 in.

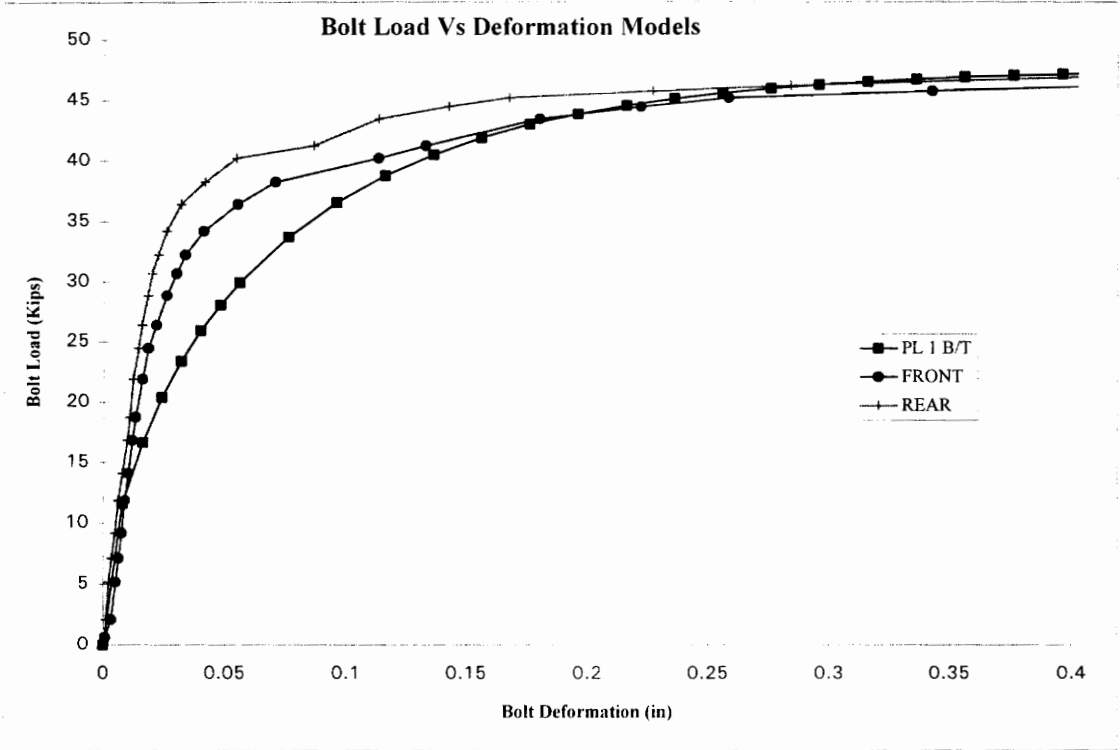

Figure C-56

Plate			Bolt		A325
	tp	Fu	B/T	Bolt Dia.	1
Plate 1	0.375	63.6	47.70	Fv	72
Plate 2	1	67.8	135.60	Bolt Shear	56.55

Richard Coefficients

$K = 0$ $K_p = 0$ $R_o = 0$
 $K_1 = 0$ $n = 0$

Data Point	Volts	Load	F1	F2	F3	F4	R1	R2	R3	R4	AVG(F)	AVG(R)
1	0.04	0.66	0.000	0.001	-0.002	-0.001	-0.002	-0.001	0.000	-0.001	0.001	0.001
2	0.14	2.12	0.000	0.001	-0.007	-0.006	-0.001	0.001	-0.004	-0.001	0.003	0.001
3	0.35	5.20	0.000	0.001	-0.011	-0.011	-0.003	-0.001	-0.004	-0.001	0.005	0.002
4	0.48	7.18	0.000	0.001	-0.014	-0.013	-0.006	-0.004	-0.004	-0.001	0.006	0.004
5	0.62	9.23	-0.001	0.001	-0.016	-0.015	-0.008	-0.006	-0.004	-0.001	0.008	0.005
6	0.79	11.87	-0.001	0.002	-0.019	-0.018	-0.011	-0.010	-0.004	-0.001	0.009	0.006
7	0.94	14.14	-0.001	0.002	-0.022	-0.020	-0.014	-0.013	-0.003	-0.001	0.010	0.008
8	1.12	16.85	-0.003	0.003	-0.025	-0.022	-0.015	-0.020	-0.001	-0.002	0.012	0.010
9	1.25	18.76	-0.004	0.003	-0.028	-0.024	-0.016	-0.025	0.001	-0.002	0.013	0.011
10	1.46	21.91	-0.007	0.004	-0.035	-0.026	-0.016	-0.035	0.004	-0.002	0.016	0.012
11	1.63	24.47	-0.010	0.006	-0.042	-0.028	-0.017	-0.042	0.003	-0.002	0.018	0.015
12	1.76	26.38	-0.015	0.007	-0.049	-0.030	-0.017	-0.048	0.004	-0.002	0.022	0.016
13	1.92	28.87	-0.019	0.007	-0.057	-0.035	-0.018	-0.056	0.006	-0.004	0.026	0.018
14	2.05	30.70	-0.023	0.006	-0.064	-0.039	-0.020	-0.061	0.006	-0.004	0.030	0.020
15	2.15	32.24	-0.026	0.005	-0.070	-0.043	-0.022	-0.067	0.002	-0.004	0.034	0.022
16	2.28	34.22	-0.032	0.001	-0.081	-0.052	-0.028	-0.075	0.003	-0.004	0.041	0.026
17	2.43	36.42	-0.043	-0.011	-0.098	-0.069	-0.037	-0.086	-0.001	-0.004	0.055	0.032
18	2.55	38.25	-0.056	-0.024	-0.116	-0.087	-0.052	-0.100	-0.011	-0.004	0.071	0.042
19	2.68	40.24	-0.091	-0.066	-0.165	-0.132	-0.069	-0.113	-0.026	-0.010	0.113	0.055
20	2.75	41.25	-0.109	-0.084	-0.186	-0.152	-0.090	-0.132	-0.042	-0.081	0.133	0.086
21	2.90	43.46	-0.155	-0.130	-0.235	-0.200	-0.129	-0.169	-0.073	-0.081	0.180	0.113
22	2.97	44.49	-0.196	-0.170	-0.278	-0.245	-0.169	-0.209	-0.109	-0.081	0.222	0.142
23	3.01	45.22	-0.231	-0.206	-0.315	-0.283	-0.204	-0.244	-0.141	-0.081	0.259	0.167
24	3.05	45.80	-0.313	-0.291	-0.401	-0.366	-0.285	-0.324	-0.217	-0.081	0.343	0.227
25	3.08	46.24	-0.385	-0.363	-0.474	-0.440	-0.356	-0.395	-0.286	-0.100	0.416	0.284
26	3.14	47.05	-0.519	-0.498	-0.611	-0.575	-0.490	-0.529	-0.418	-0.230	0.551	0.417
27	3.19	47.85	-0.648	-0.628	-0.744	-0.708	-0.622	-0.661	-0.546	-0.360	0.682	0.547
28	3.28	49.17	-0.731	-0.713	-0.817	-0.794	-0.709	-0.748	-0.632	-0.444	0.764	0.633
29	3.33	49.98	-0.793	-0.774	-0.817	-0.855	-0.770	-0.808	-0.691	-0.504	0.810	0.693
30	3.37	50.49	-0.893	-0.820	-0.819	-0.921	-0.774	-0.828	-0.788	-0.605	0.863	0.749
31	3.33	49.98	-0.945	-0.823	-0.820	-0.921	-0.776	-0.833	-0.839	-0.653	0.877	0.775

Table C-56

TENSION TESTS ON BOLTED CONNECTIONS

SUMMARY SHEET

Test No: 57

Date: April 7, 1995

Test Designation: 1/2x1/2x1

Recorder: Burak Karsu

GEOMETRIC AND MATERIAL PROPERTIES

BOLT

Type:A325

Diameter $d_b=1.0$ in.

Length $L_b=2.5$ in.

Shear Str. $F_v=72$ ksi

Edge Dist. $e=2.0$ in.

Fully Pretensioned--Yes

Bolt Hole Fabr.--Drilled

Bolt Hole Type--Standard

Threads in Shear Plane--N

PLATES

No	Designation	Length (in.)	Width (in.)	Thickness (in.)	Hole Dia. (in.)	Fy (ksi)	Fu (ksi)
Plate 1	PL-34	24.0	4.0	0.5	17/16	51.8	73.8
Plate 2	PL-34	24.0	4.0	0.5	17/16	51.8	73.8

TEST RESULTS

Failure Type: Bolt Shear

Failure Load: 57340 lbs/bolt

Max Deflection $\Delta_{max}=0.51$ in.

Failure Plate: N/A

COMMENTS

- * PL-34 yielded at 39000 lbs. with a deformation of 0.065 in.
- * The connection went through the plastic portion.
- * Bolt sheared in the threaded part.

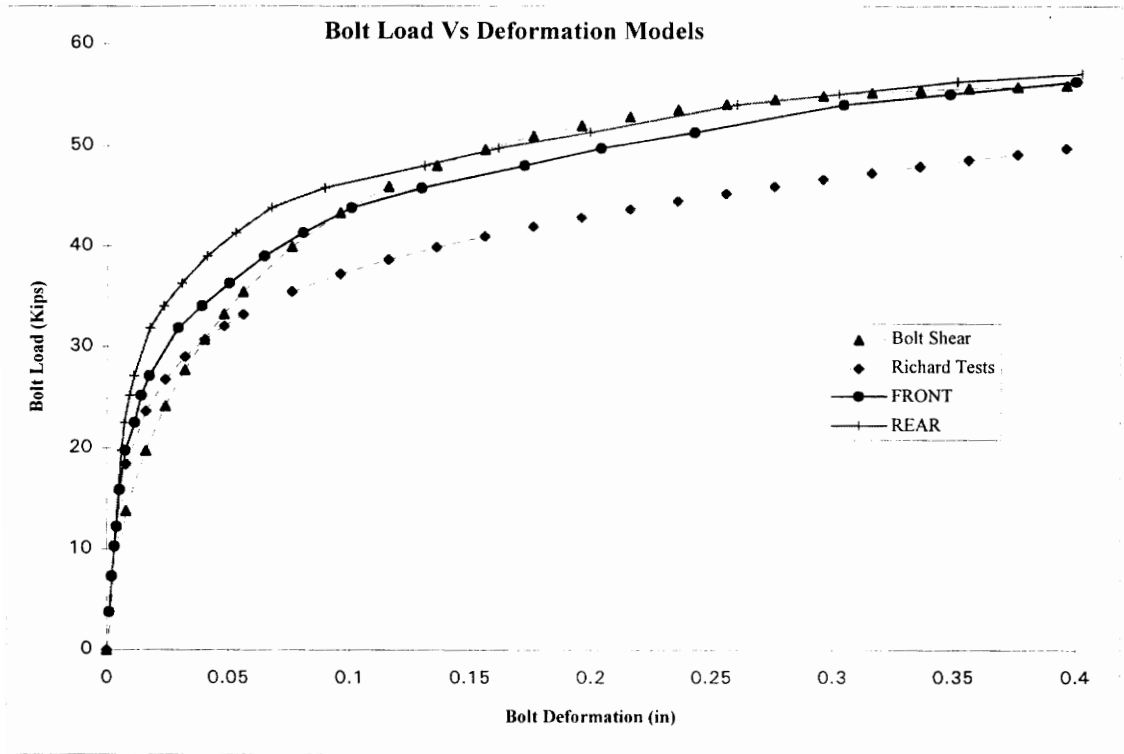

Figure C-57

Plate	tp	Fu	B/T	Bolt	A325
Plate 1	0.5	73.8	73.80	Bolt Dia.	1
Plate 2	0.5	73.8	73.80	Fv	72
				Bolt Shear	56.55

Richard Coefficients

K= 14500 Kp= 20 Ro= 50
 K1= 14480 n= 0.5

Data Point	Volts	Load	F1	F2	F3	F4	R1	R2	R3	R4	AVG(F)	AVG(R)
1	0.25	3.74	-0.001	-0.001	-0.002	-0.001	-0.002	-0.001	-0.001	-0.001	0.001	0.001
2	0.49	7.32	-0.001	-0.001	-0.004	-0.003	-0.002	-0.002	-0.002	-0.001	0.002	0.002
3	0.68	10.26	-0.002	-0.002	-0.005	-0.004	-0.003	-0.004	-0.004	-0.002	0.003	0.003
4	0.82	12.24	-0.002	-0.003	-0.006	-0.005	-0.004	-0.004	-0.005	-0.002	0.004	0.004
5	1.06	15.83	-0.003	-0.004	-0.008	-0.007	-0.004	-0.005	-0.007	-0.004	0.005	0.005
6	1.32	19.78	-0.006	-0.006	-0.012	-0.008	-0.005	-0.007	-0.007	-0.004	0.008	0.006
7	1.50	22.49	-0.010	-0.008	-0.017	-0.010	-0.006	-0.008	-0.008	-0.007	0.011	0.007
8	1.68	25.20	-0.013	-0.010	-0.021	-0.013	-0.006	-0.013	-0.009	-0.010	0.014	0.009
9	1.81	27.12	-0.017	-0.012	-0.024	-0.016	-0.007	-0.015	-0.010	-0.013	0.017	0.011
10	2.13	31.88	-0.029	-0.023	-0.038	-0.028	-0.014	-0.022	-0.016	-0.018	0.029	0.018
11	2.27	34.08	-0.037	-0.032	-0.048	-0.038	-0.020	-0.028	-0.022	-0.024	0.039	0.023
12	2.42	36.32	-0.048	-0.043	-0.061	-0.049	-0.027	-0.035	-0.030	-0.031	0.050	0.031
13	2.60	39.04	-0.063	-0.057	-0.075	-0.064	-0.040	-0.045	-0.041	-0.038	0.065	0.041
14	2.76	41.37	-0.078	-0.073	-0.092	-0.079	-0.054	-0.056	-0.053	-0.048	0.081	0.053
15	2.92	43.86	-0.098	-0.094	-0.112	-0.098	-0.069	-0.071	-0.068	-0.062	0.101	0.068
16	3.06	45.84	-0.129	-0.123	-0.141	-0.126	-0.091	-0.091	-0.091	-0.085	0.130	0.090
17	3.20	48.04	-0.171	-0.166	-0.183	-0.169	-0.131	-0.130	-0.134	-0.129	0.172	0.131
18	3.32	49.80	-0.204	-0.197	-0.215	-0.201	-0.162	-0.160	-0.165	-0.159	0.204	0.161
19	3.42	51.33	-0.244	-0.235	-0.253	-0.240	-0.200	-0.199	-0.203	-0.197	0.243	0.199
20	3.60	54.04	-0.305	-0.297	-0.314	-0.302	-0.261	-0.259	-0.266	-0.256	0.305	0.260
21	3.67	55.07	-0.349	-0.340	-0.358	-0.345	-0.303	-0.300	-0.309	-0.298	0.348	0.302
22	3.75	56.31	-0.400	-0.393	-0.409	-0.397	-0.351	-0.349	-0.357	-0.348	0.400	0.351
23	3.81	57.12	-0.454	-0.446	-0.462	-0.451	-0.401	-0.400	-0.410	-0.399	0.453	0.402
24	3.82	57.34	-0.506	-0.499	-0.513	-0.502	-0.457	-0.454	-0.464	-0.451	0.505	0.457

Table C-57

TENSION TESTS ON BOLTED CONNECTIONS

SUMMARY SHEET

Test No: 58

Date: April 8, 1995

Test Designation: 1/2x5/8x1

Recorder: Burak Karsu

GEOMETRIC AND MATERIAL PROPERTIES

BOLT

Type: A325

Diameter $d_b=1.0$ in.

Length $L_b=2.75$ in.

Shear Str. $F_v=72$ ksi

Edge Dist. $e=2.0$ in.

Fully Pretensioned--Yes

Bolt Hole Fabr.--Drilled

Bolt Hole Type--Standard

Threads in Shear Plane--X

PLATES

No	Designation	Length (in.)	Width (in.)	Thickness (in.)	Hole Dia. (in.)	Fy (ksi)	Fu (ksi)
Plate 1	PL-34	24.0	4.0	0.5	17/16	51.8	73.8
Plate 2	PL-27a	24.0	4.0	0.625	17/16	45.4	68.4

TEST RESULTS

Failure Type: Bolt Shear

Failure Load: 63200 lbs/bolt

Max Deflection $\Delta_{max}=0.52$ in.

Failure Plate: N/A

COMMENTS

* PL-34 yielded at 39000 lbs with a deformation of 0.035 in.

* The connection went through the plastic portion and gained strength.

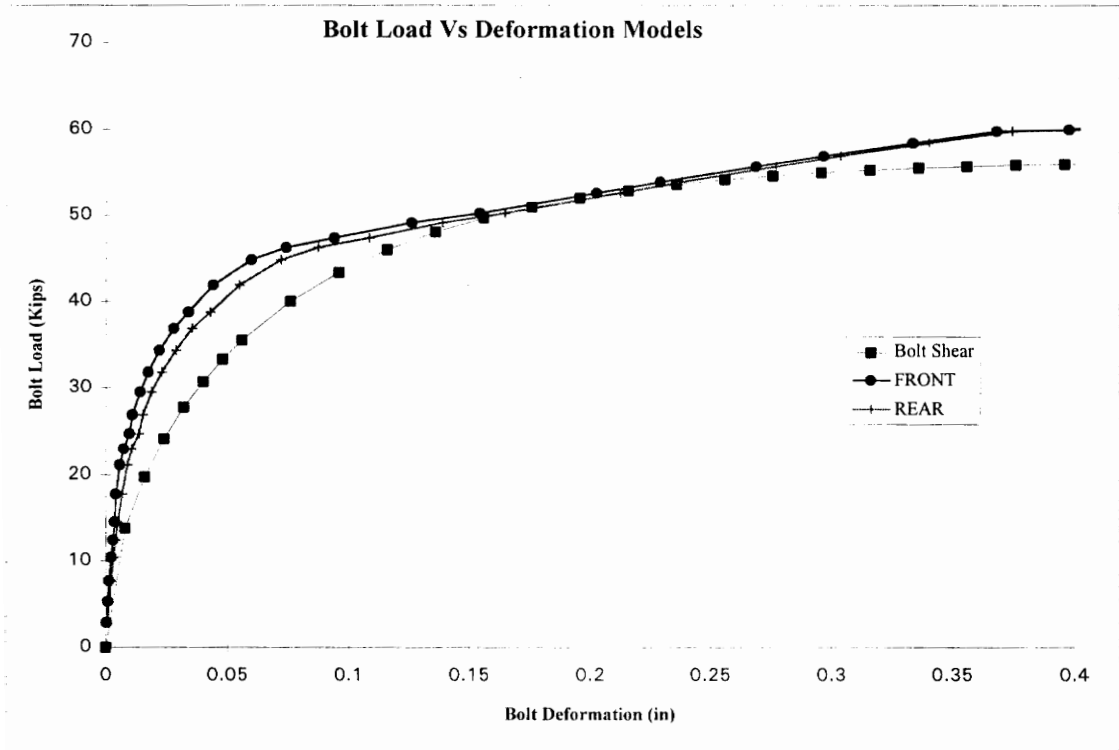

Figure C-58

Plate				Bolt		A325
	tp	Fu	B/T	Bolt Dia.		
Plate 1	0.5	73.8	73.80	Fv		72
Plate 2	0.625	68.4	85.50	Bolt Shear		56.55

Richard Coefficients

K= 0 Kp= 0 Ro= 0
 K1= 0 n= 0

Data Point	Volts	Load	F1	F2	F3	F4	R1	R2	R3	R4	AVG(F)	AVG(R)
1	0.19	2.86	-0.001	0.000	0.000	-0.001	-0.002	-0.001	0.000	0.000	0.000	0.001
2	0.36	5.34	-0.001	0.000	-0.001	-0.001	-0.003	-0.002	-0.001	0.000	0.001	0.001
3	0.51	7.69	-0.002	-0.001	-0.001	-0.002	-0.004	-0.003	-0.001	-0.001	0.001	0.002
4	0.70	10.46	-0.002	-0.002	-0.002	-0.002	-0.006	-0.006	-0.001	-0.001	0.002	0.003
5	0.83	12.45	-0.004	-0.002	-0.003	-0.003	-0.007	-0.007	-0.001	-0.002	0.003	0.004
6	0.97	14.58	-0.004	-0.002	-0.004	-0.004	-0.007	-0.009	-0.001	-0.002	0.004	0.005
7	1.19	17.80	-0.005	-0.002	-0.006	-0.004	-0.009	-0.012	-0.002	-0.005	0.004	0.007
8	1.41	21.17	-0.006	-0.003	-0.009	-0.006	-0.010	-0.016	-0.002	-0.008	0.006	0.009
9	1.53	23.00	-0.009	-0.003	-0.012	-0.007	-0.010	-0.020	-0.002	-0.011	0.007	0.011
10	1.65	24.76	-0.012	-0.004	-0.015	-0.008	-0.012	-0.024	-0.003	-0.015	0.010	0.014
11	1.79	26.88	-0.012	-0.006	-0.017	-0.009	-0.014	-0.026	-0.004	-0.017	0.011	0.015
12	1.97	29.53	-0.015	-0.008	-0.021	-0.012	-0.017	-0.031	-0.006	-0.021	0.014	0.019
13	2.12	31.80	-0.019	-0.010	-0.025	-0.015	-0.021	-0.036	-0.009	-0.025	0.017	0.023
14	2.29	34.29	-0.023	-0.015	-0.030	-0.020	-0.028	-0.042	-0.014	-0.031	0.022	0.029
15	2.46	36.85	-0.029	-0.020	-0.036	-0.027	-0.036	-0.050	-0.021	-0.036	0.028	0.035
16	2.58	38.75	-0.034	-0.027	-0.042	-0.034	-0.045	-0.057	-0.027	-0.042	0.034	0.043
17	2.79	41.90	-0.043	-0.037	-0.053	-0.045	-0.059	-0.071	-0.038	-0.051	0.044	0.055
18	2.99	44.84	-0.057	-0.052	-0.069	-0.061	-0.079	-0.089	-0.054	-0.067	0.060	0.072
19	3.08	46.23	-0.071	-0.065	-0.084	-0.076	-0.096	-0.105	-0.068	-0.080	0.074	0.087
20	3.16	47.33	-0.092	-0.086	-0.103	-0.096	-0.118	-0.125	-0.090	-0.100	0.094	0.109
21	3.27	49.11	-0.125	-0.117	-0.134	-0.128	-0.150	-0.156	-0.120	-0.130	0.126	0.139
22	3.35	50.26	-0.154	-0.145	-0.161	-0.157	-0.176	-0.182	-0.146	-0.156	0.154	0.165
23	3.51	52.61	-0.202	-0.195	-0.211	-0.204	-0.224	-0.229	-0.193	-0.205	0.203	0.213
24	3.59	53.85	-0.228	-0.221	-0.238	-0.230	-0.250	-0.255	-0.218	-0.230	0.229	0.238
25	3.71	55.61	-0.268	-0.262	-0.276	-0.270	-0.289	-0.292	-0.256	-0.271	0.269	0.277
26	3.79	56.85	-0.295	-0.290	-0.304	-0.299	-0.316	-0.319	-0.282	-0.298	0.297	0.304
27	3.89	58.39	-0.331	-0.326	-0.341	-0.336	-0.354	-0.356	-0.319	-0.333	0.334	0.340
28	3.99	59.78	-0.365	-0.362	-0.377	-0.369	-0.388	-0.389	-0.354	-0.367	0.368	0.375
29	4.00	60.00	-0.394	-0.391	-0.407	-0.399	-0.420	-0.420	-0.385	-0.399	0.398	0.406
30	4.13	61.98	-0.452	-0.448	-0.469	-0.461	-0.481	-0.480	-0.446	-0.458	0.457	0.466
31	4.21	63.16	-0.509	-0.504	-0.526	-0.518	-0.539	-0.538	-0.504	-0.516	0.514	0.524

Table C-58

TENSION TESTS ON BOLTED CONNECTIONS

SUMMARY SHEET

Test No: 59

Date: April 8, 1995

Test Designation: 1/2x3/4x1

Recorder: Burak Karsu

GEOMETRIC AND MATERIAL PROPERTIES

BOLT

Type:A325

Diameter $d_b=1.0$ in.

Length $L_b= 2.75$ in.

Shear Str. $F_v=72$ ksi

Edge Dist. $e=2.0$ in.

Fully Pretensioned--Yes

Bolt Hole Fabr.--Drilled

Bolt Hole Type--Standard

Threads in Shear Plane--X

PLATES

No	Designation	Length (in.)	Width (in.)	Thickness (in.)	Hole Dia. (in.)	Fy (ksi)	Fu (ksi)
Plate 1	PL-34	24.0	4.0	0.5	17/16	51.8	73.8
Plate 2	PL-29	24.0	4.0	0.75	17/16	44.6	70.4

TEST RESULTS

Failure Type: Bolt Shear

Failure Load: 63000 lbs/bolt

Max Deflection $\Delta_{max} = 0.46$ in.

Failure Plate: N/A

COMMENTS

* PL-34 yielded at 42000 lbs with a deformation of 0.058 in.

* PL-29 yielded at 52000 lbs with a deformation of 0.14 in.

* The connection gained strength as it went through the plastic portion.

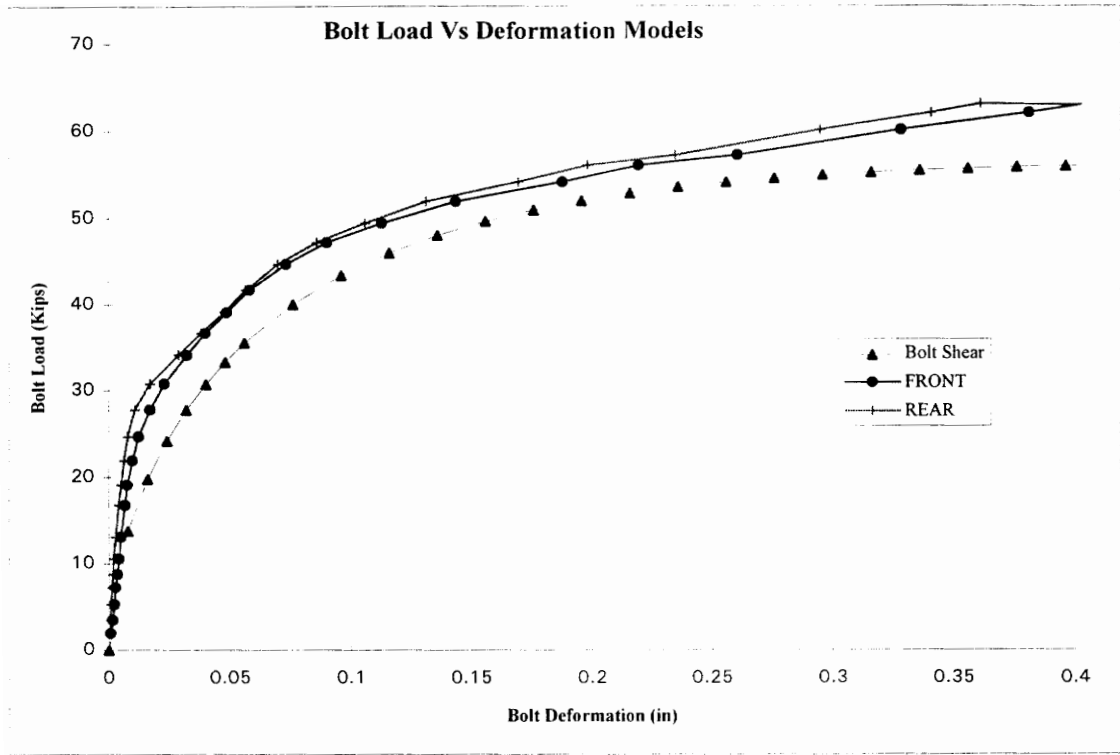

Figure C-59

Plate	tp	Fu	B/T	Bolt	A325
Plate 1	0.5	73.8	73.80	Bolt Dia.	1
Plate 2	0.75	70.4	105.60	Fv	72
				Bolt Shear	56.55

Richard Coefficients

K= 0 Kp= 0 Ro= 0
 K1= 0 n= 0

Data Point	Volts	Load	F1	F2	F3	F4	R1	R2	R3	R4	AVG(F)	AVG(R)
1	0.13	1.98	0.000	0.000	-0.001	-0.001	-0.001	-0.001	0.000	-0.001	0.000	0.001
2	0.23	3.52	-0.001	0.000	-0.003	-0.002	-0.001	-0.001	-0.001	-0.001	0.002	0.001
3	0.35	5.27	-0.001	0.000	-0.004	-0.004	-0.001	-0.001	-0.001	-0.001	0.002	0.001
4	0.48	7.25	-0.001	0.000	-0.005	-0.006	-0.002	-0.002	-0.001	-0.001	0.003	0.001
5	0.59	8.79	-0.001	0.000	-0.007	-0.007	-0.002	-0.002	-0.001	-0.001	0.004	0.002
6	0.71	10.60	-0.001	0.000	-0.008	-0.008	-0.003	-0.003	-0.001	-0.001	0.004	0.002
7	0.87	13.11	-0.001	0.000	-0.009	-0.010	-0.004	-0.004	-0.001	-0.002	0.005	0.003
8	1.12	16.77	-0.003	0.000	-0.013	-0.011	-0.005	-0.007	-0.001	-0.003	0.007	0.004
9	1.27	19.12	-0.004	0.000	-0.015	-0.012	-0.007	-0.009	-0.002	-0.004	0.008	0.005
10	1.46	21.91	-0.007	0.001	-0.020	-0.013	-0.008	-0.011	-0.002	-0.005	0.010	0.006
11	1.65	24.69	-0.011	0.001	-0.024	-0.015	-0.009	-0.014	-0.002	-0.007	0.012	0.008
12	1.85	27.77	-0.016	-0.002	-0.032	-0.018	-0.010	-0.020	-0.002	-0.011	0.017	0.011
13	2.05	30.77	-0.021	-0.006	-0.040	-0.024	-0.015	-0.028	-0.006	-0.018	0.023	0.017
14	2.27	34.07	-0.030	-0.012	-0.052	-0.035	-0.031	-0.038	-0.019	-0.027	0.032	0.029
15	2.44	36.63	-0.036	-0.018	-0.062	-0.043	-0.043	-0.046	-0.030	-0.033	0.040	0.038
16	2.60	39.06	-0.043	-0.024	-0.073	-0.053	-0.056	-0.055	-0.041	-0.039	0.049	0.048
17	2.78	41.69	-0.052	-0.031	-0.085	-0.064	-0.068	-0.064	-0.050	-0.045	0.058	0.057
18	2.78	41.69	-0.052	-0.031	-0.085	-0.064	-0.068	-0.064	-0.050	-0.045	0.058	0.057
19	2.98	44.70	-0.065	-0.043	-0.103	-0.081	-0.085	-0.076	-0.064	-0.054	0.073	0.070
20	3.15	47.19	-0.080	-0.057	-0.123	-0.100	-0.105	-0.094	-0.078	-0.066	0.090	0.086
21	3.30	49.46	-0.103	-0.076	-0.149	-0.124	-0.130	-0.116	-0.097	-0.081	0.113	0.106
22	3.46	51.95	-0.134	-0.106	-0.182	-0.153	-0.159	-0.143	-0.120	-0.103	0.144	0.131
23	3.61	54.15	-0.179	-0.150	-0.228	-0.196	-0.201	-0.180	-0.159	-0.138	0.188	0.170
24	3.74	56.05	-0.211	-0.182	-0.260	-0.226	-0.230	-0.210	-0.188	-0.165	0.220	0.198
25	3.82	57.23	-0.252	-0.223	-0.302	-0.266	-0.268	-0.246	-0.225	-0.200	0.261	0.235
26	4.01	60.09	-0.321	-0.289	-0.371	-0.333	-0.329	-0.308	-0.285	-0.257	0.328	0.295
27	4.14	62.06	-0.373	-0.341	-0.424	-0.385	-0.375	-0.355	-0.331	-0.301	0.381	0.341
28	4.21	63.09	-0.396	-0.365	-0.449	-0.409	-0.396	-0.376	-0.352	-0.320	0.405	0.361
29	4.20	62.94	-0.451	-0.419	-0.503	-0.463	-0.444	-0.421	-0.396	-0.366	0.459	0.407

Table C-59

TENSION TESTS ON BOLTED CONNECTIONS

SUMMARY SHEET

Test No: 60

Date: April 7, 1995

Test Designation: 1/2x1x1

Recorder: Burak Karsu

GEOMETRIC AND MATERIAL PROPERTIES

BOLT

Type: A325

Diameter $d_b=1.0$ in.

Length $L_b=3.0$ in.

Shear Str. $F_v=72$ ksi

Edge Dist. $e=2.0$ in.

Fully Pretensioned--Yes

Bolt Hole Fabr.--Drilled

Bolt Hole Type--Standard

Threads in Shear Plane--X

PLATES

No	Designation	Length (in.)	Width (in.)	Thickness (in.)	Hole Dia. (in.)	F _y (ksi)	F _u (ksi)
Plate 1	PL-35	24.0	4.0	0.5	17/16	52.7	73.6
Plate 2	PL-31	24.0	4.0	1.0	17/16	42.1	67.8

TEST RESULTS

Failure Type: Bolt Shear.

Failure Load: 58800 lbs/bolt

Max Deflection $\Delta_{max}=0.24$ in.

Failure Plate: N/A

COMMENTS

- * Yielding started on PL-35 at a deformation of 0.04 in. with a load of 45000 lbs.
- * Bulging on PL-35 started at a deformation of 0.2 in.
- * The connection had a short plastic period.

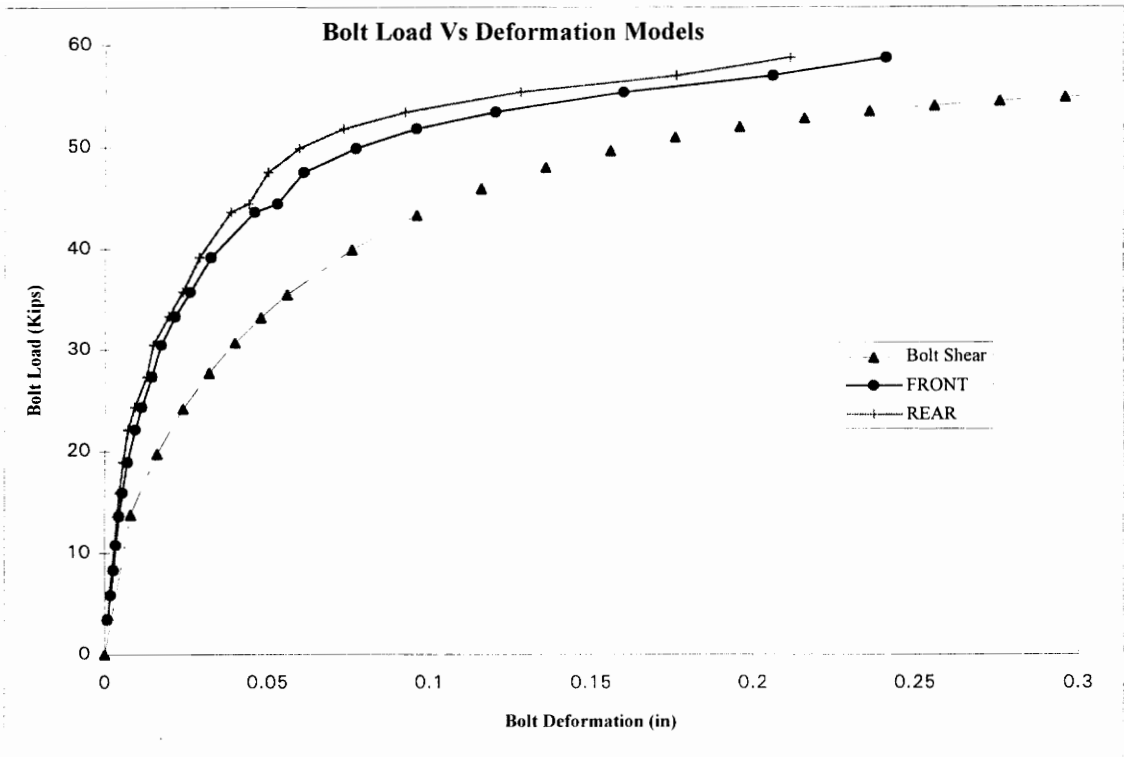

Figure C-60

Plate	tp	Fu	B/T	Bolt	A325
Plate 1	0.5	73.6	73.60	Bolt Dia.	1
Plate 2	1	67.8	135.60	Fv	72
				Bolt Shear	56.55

Richard Coefficients

K= 0 Kp= 0 Ro= 0
 K1= 0 n= 0

Data Point	Volts	Load	F1	F2	F3	F4	R1	R2	R3	R4	AVG(F)	AVG(R)
1	0.23	3.45	-0.001	0.000	-0.001	0.001	-0.002	-0.001	-0.001	-0.001	0.001	0.001
2	0.39	5.87	-0.001	-0.001	-0.004	0.000	-0.002	-0.001	-0.001	-0.001	0.002	0.001
3	0.56	8.36	-0.001	-0.001	-0.006	0.001	-0.004	-0.002	-0.002	-0.001	0.003	0.002
4	0.72	10.79	-0.002	-0.001	-0.007	0.000	-0.005	-0.003	-0.002	-0.002	0.003	0.003
5	0.91	13.65	-0.002	-0.001	-0.010	0.001	-0.007	-0.004	-0.002	-0.002	0.004	0.004
6	1.06	15.92	-0.002	-0.001	-0.013	0.001	-0.008	-0.006	-0.002	-0.003	0.006	0.005
7	1.26	18.92	-0.004	-0.001	-0.016	0.001	-0.009	-0.008	-0.002	-0.004	0.007	0.006
8	1.47	22.07	-0.007	-0.001	-0.020	0.000	-0.011	-0.010	-0.002	-0.005	0.009	0.007
9	1.62	24.34	-0.008	-0.002	-0.023	0.000	-0.010	-0.017	0.001	-0.010	0.011	0.009
10	1.82	27.35	-0.010	-0.006	-0.028	0.001	-0.010	-0.024	0.002	-0.020	0.014	0.013
11	2.03	30.50	-0.013	-0.007	-0.032	0.001	-0.011	-0.029	0.003	-0.023	0.017	0.015
12	2.22	33.35	-0.017	-0.010	-0.038	0.001	-0.013	-0.038	0.003	-0.031	0.022	0.020
13	2.38	35.77	-0.020	-0.015	-0.045	0.000	-0.015	-0.046	0.003	-0.038	0.026	0.024
14	2.61	39.22	-0.024	-0.020	-0.054	0.001	-0.017	-0.057	0.003	-0.045	0.033	0.029
15	2.91	43.69	-0.035	-0.033	-0.070	0.001	-0.023	-0.075	0.002	-0.059	0.046	0.039
16	2.97	44.49	-0.041	-0.040	-0.078	0.001	-0.026	-0.084	0.001	-0.067	0.053	0.044
17	3.17	47.57	-0.048	-0.049	-0.087	0.001	-0.032	-0.094	-0.001	-0.073	0.061	0.050
18	3.33	49.91	-0.061	-0.066	-0.105	0.001	-0.040	-0.109	-0.006	-0.085	0.077	0.060
19	3.45	51.82	-0.078	-0.087	-0.123	0.001	-0.053	-0.127	-0.014	-0.100	0.096	0.073
20	3.56	53.44	-0.100	-0.114	-0.147	0.001	-0.070	-0.150	-0.029	-0.121	0.120	0.093
21	3.69	55.42	-0.138	-0.156	-0.187	0.000	-0.101	-0.191	-0.061	-0.160	0.160	0.128
22	3.80	57.03	-0.182	-0.204	-0.233	0.000	-0.146	-0.243	-0.105	-0.211	0.206	0.176
23	3.92	58.79	-0.215	-0.240	-0.269	0.001	-0.179	-0.283	-0.136	-0.249	0.241	0.212

Table C-60

TENSION TESTS ON BOLTED CONNECTIONS

SUMMARY SHEET

Test No: 61

Date: April 8, 1995

Test Designation: 5/8x5/8x1

Recorder: Burak Karsu

GEOMETRIC AND MATERIAL PROPERTIES

BOLT

Type: A325

Diameter $d_b=1.0$ in.

Length $L_b=2.75$ in.

Shear Str. $F_v=81$ ksi

Edge Dist. $e=2.0$ in.

Fully Pretensioned--Yes

Bolt Hole Fabr.--Drilled

Bolt Hole Type--Standard

Threads in Shear Plane--X

PLATES

No	Designation	Length (in.)	Width (in.)	Thickness (in.)	Hole Dia. (in.)	Fy (ksi)	Fu (ksi)
Plate 1	PL-34	24.0	4.0	0.5	17/16	51.8	7

Plate 2

TEST RESULTS

Failure Type: Bolt Shear

Failure Load: 57500 lbs/bolt

Max Deflection $\Delta_{max}=0.30$ in.

Failure Plate: N/A

COMMENTS

TENSION TESTS ON BOLTED CONNECTIONS

SUMMARY SHEET

Test No: 62

Date: April 8, 1995

Test Designation: 5/8x3/4x1

Recorder: Burak Karsu

GEOMETRIC AND MATERIAL PROPERTIES

BOLT

Type: A325

Diameter $d_b=1.0$ in.

Length $L_b=3.0$ in.

Shear Str. $F_v=72$ ksi

Edge Dist. $e=2.0$ in.

Fully Pretensioned--Yes

Bolt Hole Fabr.--Drilled

Bolt Hole Type--Standard

Threads in Shear Plane--X

PLATES

No	Designation	Length (in.)	Width (in.)	Thickness (in.)	Hole Dia. (in.)	Fy (ksi)	Fu (ksi)
Plate 1	PL-43	24.0	4.0	0.625	17/16	43.7	63.3
Plate 2	PL-44	24.0	4.0	0.75	17/16	44.5	67.8

TEST RESULTS

Failure Type: Bolt Shear

Failure Load: 62000 lbs/bolt

Max Deflection $\Delta_{max}=0.37$ in.

Failure Plate: N/A

COMMENTS

* PL-37 yielded at 35000 lbs with a deformation of 0.025 in.

* The connection could not develop a well-defined plastic region.

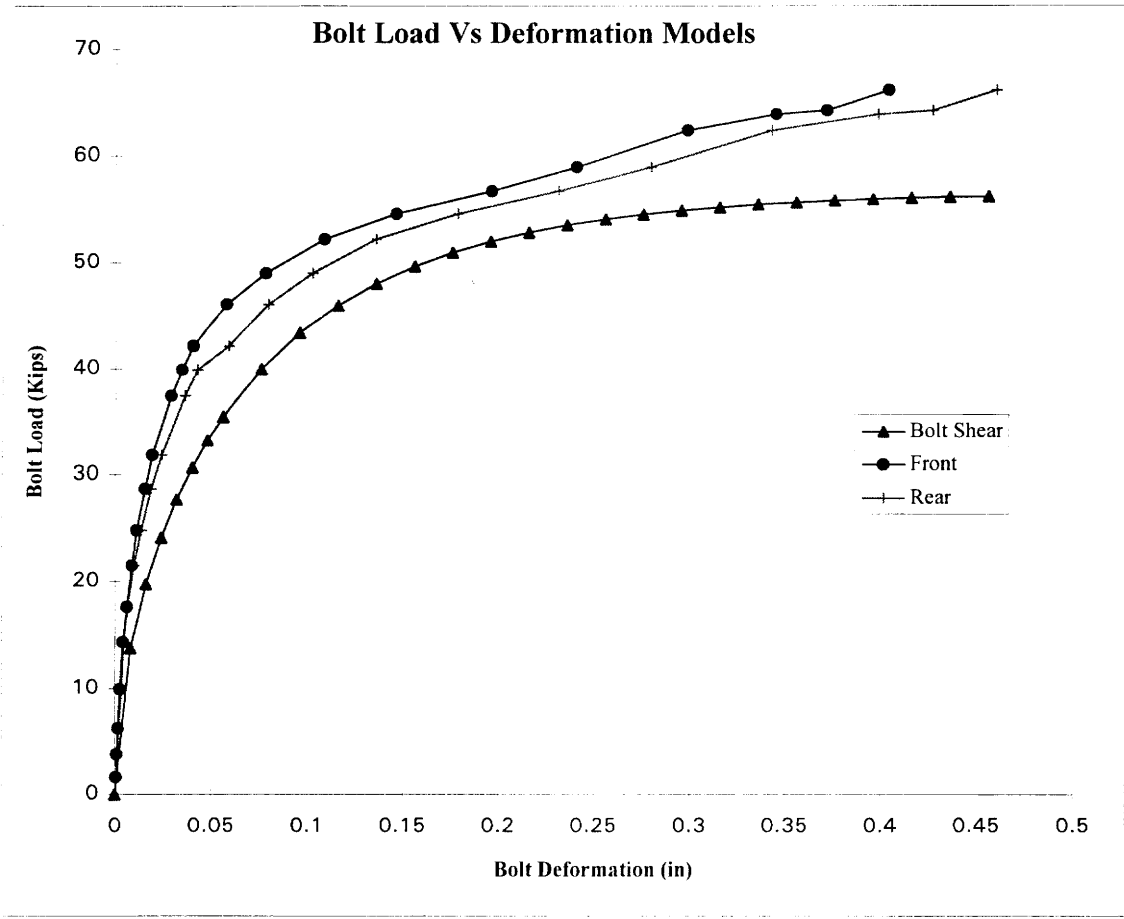

Figure C-62

Plate	tp	Fu	B/T	Bolt	A325
Plate 1	0.625	63.3	79.125	Bolt Dia	1
Plate 2	0.75	67.8	101.7	Fv	72
				Bolt Shear	56.55

Richard Coefficients

K= 0 Kp= 0 Ro= 0
 K1= 0 n= 0

Data Point	Volts	Load	F1	F2	F3	F4	R1	R2	R3	R4	AVG(F)	AVG(R)
1	0.11	1.61	-0.001	0.000	-0.001	-0.001	-0.001	-0.001	0.000	0.000	0.001	0.001
2	0.25	3.81	-0.001	0.000	-0.002	-0.002	-0.003	-0.002	0.000	0.000	0.001	0.001
3	0.42	6.23	-0.001	-0.001	-0.002	-0.002	-0.004	-0.003	-0.001	0.000	0.002	0.002
4	0.66	9.96	-0.002	-0.001	-0.004	-0.004	-0.007	-0.004	-0.001	-0.001	0.003	0.004
5	0.96	14.36	-0.003	0.000	-0.008	-0.006	-0.009	-0.006	-0.002	-0.002	0.004	0.005
6	1.18	17.65	-0.007	0.001	-0.012	-0.006	-0.013	-0.006	-0.005	-0.001	0.006	0.006
7	1.44	21.54	-0.013	0.003	-0.019	-0.006	-0.021	-0.006	-0.012	0.000	0.009	0.010
8	1.66	24.84	-0.020	0.006	-0.026	-0.005	-0.029	-0.007	-0.018	0.001	0.011	0.014
9	1.91	28.72	-0.029	0.008	-0.037	-0.004	-0.040	-0.009	-0.027	0.001	0.016	0.019
10	2.12	31.87	-0.037	0.010	-0.047	-0.003	-0.052	-0.010	-0.037	0.001	0.019	0.024
11	2.50	37.45	-0.050	0.007	-0.064	-0.009	-0.073	-0.016	-0.054	-0.002	0.029	0.036
12	2.66	39.94	-0.056	0.003	-0.072	-0.015	-0.084	-0.021	-0.062	-0.004	0.035	0.043
13	2.81	42.13	-0.062	-0.002	-0.080	-0.018	-0.109	-0.035	-0.081	-0.011	0.041	0.059
14	3.07	46.10	-0.075	-0.017	-0.099	-0.040	-0.137	-0.056	-0.102	-0.024	0.058	0.080
15	3.27	49.03	-0.093	-0.034	-0.123	-0.064	-0.166	-0.078	-0.124	-0.042	0.078	0.103
16	3.48	52.25	-0.132	-0.058	-0.154	-0.092	-0.203	-0.109	-0.160	-0.071	0.109	0.136
17	3.64	54.59	-0.165	-0.095	-0.194	-0.132	-0.249	-0.152	-0.205	-0.109	0.146	0.179
18	3.78	56.72	-0.208	-0.144	-0.247	-0.187	-0.304	-0.204	-0.259	-0.158	0.196	0.231
19	3.93	58.99	-0.250	-0.188	-0.294	-0.234	-0.354	-0.253	-0.308	-0.205	0.241	0.280
20	4.16	62.36	-0.308	-0.239	-0.355	-0.295	-0.420	-0.316	-0.372	-0.264	0.299	0.343
21	4.26	63.89	-0.360	-0.264	-0.409	-0.349	-0.477	-0.373	-0.427	-0.317	0.345	0.399
22	4.28	64.26	-0.386	-0.287	-0.437	-0.377	-0.506	-0.401	-0.457	-0.344	0.372	0.427
23	4.41	66.17	-0.420	-0.314	-0.473	-0.411	-0.539	-0.434	-0.490	-0.377	0.404	0.460

Table C-62

TENSION TESTS ON BOLTED CONNECTIONS

SUMMARY SHEET

Test No: 63

Date: April 8, 1995

Test Designation: 5/8x1x1

Recorder: Burak Karsu

GEOMETRIC AND MATERIAL PROPERTIES

BOLT

Type:A325 Diameter $d_b=1.0$ in. Length $L_b= 3.25$ in.

Shear Str. $F_v=72$ ksi Edge Dist. $e=2.0$ in. Fully Pretensioned--Yes

Bolt Hole Fabr.--Drilled Bolt Hole Type--Standard

Threads in Shear Plane--N

PLATES

No	Designation	Length (in.)	Width (in.)	Thickness (in.)	Hole Dia. (in.)	Fy (ksi)	Fu (ksi)
Plate 1	PL-37	24.0	4.0	0.625	17/16	44.9	68.2
Plate 2	PL-31	24.0	4.0	1.0	17/16	42.1	67.8

TEST RESULTS

Failure Type: Bolt Shear

Failure Load: 68000 lbs/bolt

Max Deflection $\Delta_{max}= 0.45$ in.

Failure Plate: N/A

COMMENTS

* PL-37 started yielding at a load of 32000 lbs with a deformation of 0.025 in.

* The connection was unable to develop plastic region.

TENSION TESTS ON BOLTED CONNECTIONS

SUMMARY SHEET

Test No: 64

Date: April 8, 1995

Test Designation: 3/4x3/4x1

Recorder: Burak Karsu

GEOMETRIC AND MATERIAL PROPERTIES

BOLT

Type:A325

Diameter $d_b=1.0$ in.

Length $L_b=$

Shear Str. $F_v=72$ ksi

Edge Dist. $e=2.0$ in.

Fully Pretensioned--Yes

Bolt Hole Fabr.--Drilled

Bolt Hole Type--Standard

Threads in Shear Plane--X

PLATES

No	Designation	Length (in.)	Width (in.)	Thickness (in.)	Hole Dia. (in.)	Fy (ksi)	Fu (ksi)
Plate 1	PL-44	24.0	5.0	0.75	17/16	44.5	67.8
Plate 2	PL-44	24.0	5.0	0.75	17/16	44.5	67.8

TEST RESULTS

Failure Type: Bolt Shear

Failure Load: 61000 lbs/bolt

Max Deflection $\Delta_{max}=0.2$ in.

Failure Plate: N/A

COMMENTS

* PL-44 yielded on 32500 lbs with a deformation of 0.03 in.

* The connection could not develop a plastic region.

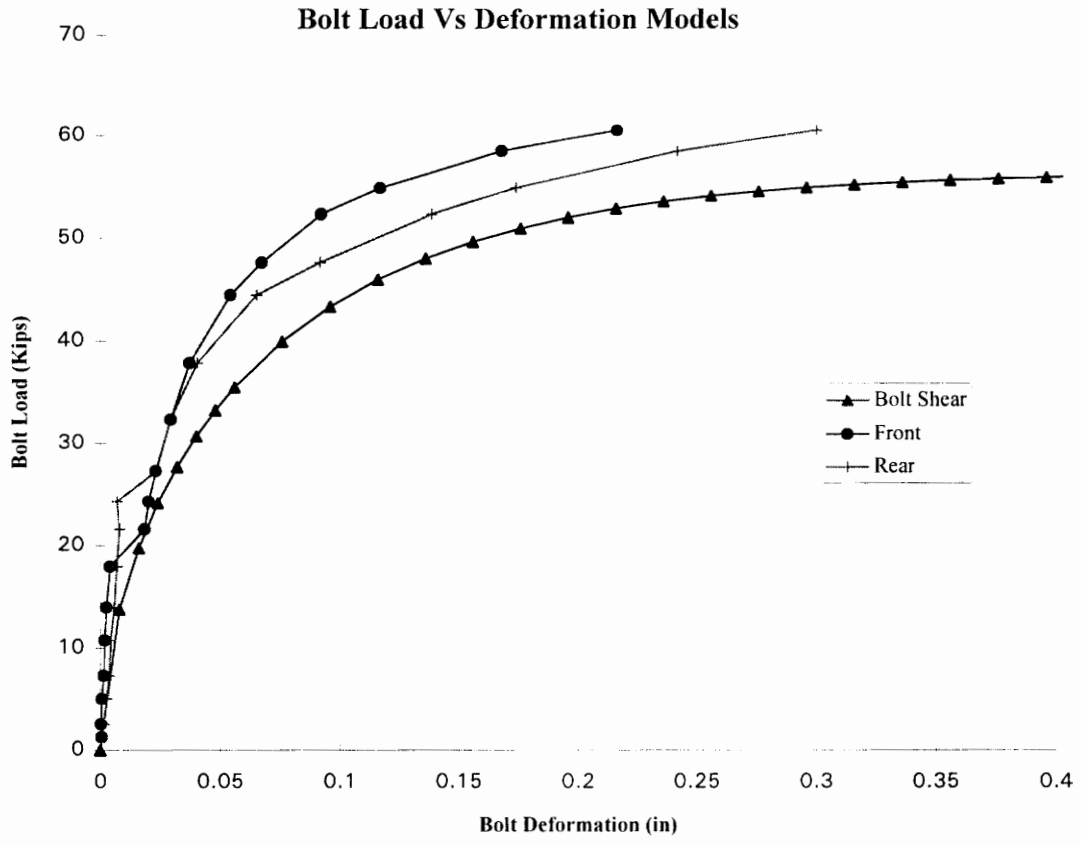

Figure C-64

Plate	tp	Fu	B/T	Bolt	A325
Plate 1	0.75	67.8	101.7	Bolt Dia.	1
Plate 2	0.75	67.8	101.7	Fv	72
				Bolt Shear	56.55

Richard Coefficients

K= 0 Kp= 0 Ro= 0
 K1= 0 n= 0

Data Point	Volts	Load	F1	F2	F3	F4	R1	R2	R3	R4	AVG(F)	AVG(R)
1	0.09	1.32	-0.001	-0.001	-0.001	0.000	-0.001	-0.001	-0.001	-0.001	0.001	0.001
2	0.17	2.56	-0.001	-0.002	0.001	0.001	-0.002	-0.002	-0.001	-0.001	0.000	0.002
3	0.34	5.05	-0.002	-0.002	0.001	0.001	-0.005	-0.005	-0.001	-0.001	0.001	0.003
4	0.49	7.32	-0.002	-0.004	-0.001	0.001	-0.007	-0.006	-0.001	-0.001	0.002	0.004
5	0.72	10.77	-0.002	-0.004	-0.001	0.001	-0.009	-0.007	-0.001	-0.001	0.002	0.004
6	0.93	13.99	-0.002	-0.007	-0.001	-0.001	-0.012	-0.009	-0.003	0.000	0.003	0.006
7	1.20	17.94	-0.002	-0.010	0.001	-0.004	-0.014	-0.009	-0.004	0.000	0.004	0.007
8	1.44	21.62	-0.008	-0.058	0.008	-0.016	-0.031	-0.020	-0.021	-0.014	0.019	0.021
9	1.62	24.33	-0.006	-0.064	0.012	-0.023	-0.032	-0.020	-0.022	-0.014	0.020	0.022
10	1.82	27.33	-0.002	-0.074	0.015	-0.031	-0.034	-0.021	-0.023	-0.015	0.023	0.023
11	2.16	32.38	0.004	-0.092	0.022	-0.051	-0.042	-0.027	-0.030	-0.018	0.029	0.029
12	2.53	37.88	0.007	-0.112	0.026	-0.070	-0.054	-0.038	-0.042	-0.028	0.037	0.041
13	2.97	44.48	0.003	-0.141	0.021	-0.101	-0.081	-0.061	-0.067	-0.051	0.054	0.065
14	3.18	47.63	-0.004	-0.158	0.013	-0.121	-0.108	-0.088	-0.094	-0.077	0.067	0.092
15	3.49	52.32	-0.021	-0.188	-0.007	-0.152	-0.154	-0.135	-0.140	-0.125	0.092	0.139
16	3.66	54.89	-0.042	-0.214	-0.030	-0.181	-0.189	-0.170	-0.177	-0.161	0.117	0.174
17	3.90	58.47	-0.090	-0.267	-0.079	-0.236	-0.256	-0.236	-0.246	-0.229	0.168	0.242
18	4.04	60.53	-0.136	-0.316	-0.128	-0.285	-0.312	-0.294	-0.306	-0.289	0.216	0.300

Table C-64

TENSION TESTS ON BOLTED CONNECTIONS

SUMMARY SHEET

Test No: 65

Date: April 9, 1995

Test Designation: 1/8x1/8x3/4

Recorder: Burak Karsu

GEOMETRIC AND MATERIAL PROPERTIES

BOLT

Type:A325 Diameter $d_b=0.75$ in. Length $L_b=1.75$ in.

Shear Str. $F_v=72$ ksi Edge Dist. $e=1.125$ in. Fully Pretensioned--Yes

Bolt Hole Fabr.--Drilled Bolt Hole Type--Standard

Threads in Shear Plane--X

PLATES

No	Designation	Length (in.)	Width (in.)	Thickness (in.)	Hole Dia. (in.)	Fy (ksi)	Fu (ksi)
Plate 1	PL-17	24.0	5.0	0.125	14/16	44.1	62.0
Plate 2	PL-17	24.0	5.0	0.125	14/16	44.1	62.0

TEST RESULTS

Failure Type: Bearing / Tear Out

Failure Load:14000 lbs/plate

Max Deflection $\Delta_{max}=0.80$ in.

Failure Plate: PL-17

COMMENTS

* PL-17 yielded at a load of 12200 lbs with a deformation of 0.02 in.

* A decrease in strength observed after yielding.

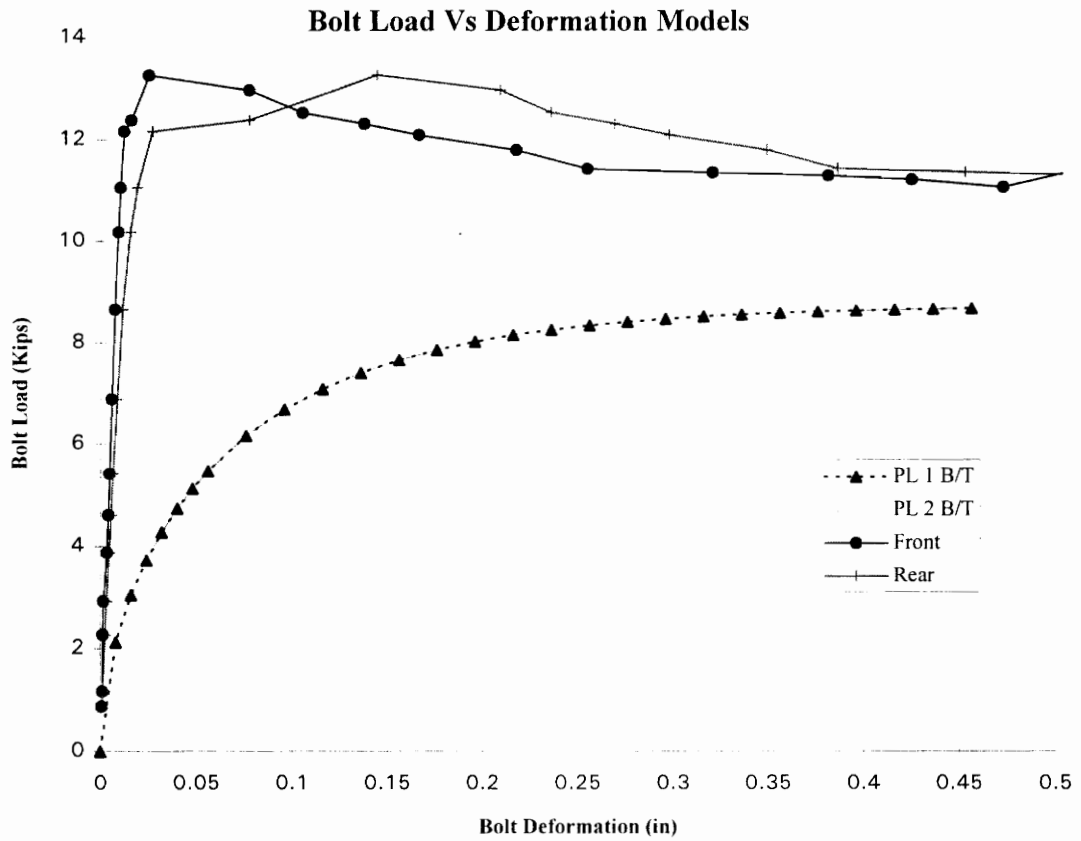

Figure C-65

Plate	tp	Fu	B/T	Bolt	A325
Plate 1	0.125	62	8.72	Bolt Dia.	0.75
Plate 2	0.125	62	8.72	Fv	72
				Bolt Shear	31.81

Richard Coefficients

K= 0 Kp= 0 Ro= 0
 K1= 0 n= 0

Data Point	Volts	Load	F1	F2	F3	F4	R1	R2	R3	R4	AVG(F)	AVG(R)
1	0.06	0.88	-0.001	-0.001	-0.001	-0.001	-0.001	-0.001	-0.001	0.000	0.001	0.001
2	0.08	1.17	-0.001	-0.002	-0.001	-0.001	-0.002	-0.002	-0.001	-0.001	0.001	0.001
3	0.15	2.27	0.000	-0.002	-0.001	-0.002	-0.004	-0.003	-0.002	-0.001	0.001	0.002
4	0.20	2.93	0.000	-0.003	-0.001	-0.003	-0.005	-0.004	-0.003	-0.001	0.002	0.003
5	0.26	3.88	-0.004	-0.004	-0.001	-0.005	-0.008	-0.004	-0.006	-0.001	0.004	0.005
6	0.31	4.61	-0.004	-0.005	-0.002	-0.007	-0.009	-0.005	-0.006	-0.003	0.004	0.006
7	0.36	5.42	-0.004	-0.006	-0.002	-0.008	-0.009	-0.006	-0.007	-0.004	0.005	0.007
8	0.46	6.88	-0.002	-0.008	-0.002	-0.011	-0.011	-0.007	-0.009	-0.007	0.006	0.009
9	0.58	8.64	-0.002	-0.011	-0.002	-0.015	-0.012	-0.011	-0.011	-0.011	0.007	0.011
10	0.68	10.18	-0.002	-0.014	-0.002	-0.018	-0.014	-0.016	-0.014	-0.017	0.009	0.015
11	0.74	11.06	-0.002	-0.016	-0.002	-0.020	-0.016	-0.020	-0.017	-0.022	0.010	0.019
12	0.81	12.16	-0.002	-0.020	-0.003	-0.023	-0.021	-0.030	-0.023	-0.032	0.012	0.027
13	0.83	12.38	-0.002	-0.026	-0.004	-0.029	-0.070	-0.081	-0.073	-0.085	0.016	0.077
14	0.88	13.26	-0.006	-0.042	-0.007	-0.045	-0.137	-0.148	-0.140	-0.151	0.025	0.144
15	0.86	12.96	-0.051	-0.104	-0.049	-0.105	-0.200	-0.214	-0.204	-0.217	0.077	0.209
16	0.83	12.52	-0.080	-0.131	-0.077	-0.133	-0.228	-0.240	-0.231	-0.244	0.105	0.236
17	0.82	12.30	-0.111	-0.163	-0.109	-0.166	-0.261	-0.274	-0.264	-0.277	0.137	0.269
18	0.81	12.08	-0.140	-0.192	-0.138	-0.195	-0.290	-0.303	-0.293	-0.305	0.166	0.298
19	0.79	11.79	-0.191	-0.243	-0.190	-0.247	-0.341	-0.355	-0.344	-0.356	0.218	0.349
20	0.76	11.43	-0.228	-0.280	-0.227	-0.284	-0.378	-0.393	-0.380	-0.393	0.255	0.386
21	0.76	11.35	-0.294	-0.347	-0.292	-0.350	-0.443	-0.460	-0.446	-0.460	0.321	0.452
22	0.75	11.29	-0.355	-0.408	-0.352	-0.410	-0.504	-0.522	-0.507	-0.519	0.381	0.513
23	0.75	11.21	-0.399	-0.452	-0.396	-0.453	-0.546	-0.566	-0.551	-0.563	0.425	0.556
24	0.74	11.06	-0.447	-0.500	-0.443	-0.500	-0.593	-0.614	-0.599	-0.610	0.473	0.604
25	0.76	11.35	-0.481	-0.534	-0.477	-0.534	-0.627	-0.647	-0.632	-0.645	0.506	0.638
26	0.72	10.77	-0.514	-0.568	-0.510	-0.569	-0.663	-0.682	-0.666	-0.680	0.540	0.673
27	0.73	10.91	-0.572	-0.626	-0.569	-0.627	-0.720	-0.742	-0.724	-0.736	0.598	0.730
28	0.72	10.77	-0.615	-0.669	-0.612	-0.670	-0.763	-0.786	-0.769	-0.778	0.641	0.774
29	0.69	10.33	-0.646	-0.699	-0.642	-0.701	-0.803	-0.826	-0.810	-0.820	0.672	0.815
30	0.43	6.45	-0.657	-0.712	-0.653	-0.712	-0.921	-0.921	-0.932	-0.920	0.683	0.924

Table C-65

TENSION TESTS ON BOLTED CONNECTIONS

SUMMARY SHEET

Test No: 66

Date: April 9, 1995

Test Designation: 1/4x1/4x3/4

Recorder: Burak Karsu

GEOMETRIC AND MATERIAL PROPERTIES

BOLT

Type: A325

Diameter $d_b=0.75$ in.

Length $L_b=2.0$ in.

Shear Str. $F_v=72$ ksi

Edge Dist. $e=1.125$ in.

Fully Pretensioned--Yes

Bolt Hole Fabr.--Drilled

Bolt Hole Type--Standard

Threads in Shear Plane--X

PLATES

<u>No</u>	<u>Designation</u>	<u>Length (in.)</u>	<u>Width (in.)</u>	<u>Thickness (in.)</u>	<u>Hole Dia. (in.)</u>	<u>Fy (ksi)</u>	<u>Fu (ksi)</u>
Plate 1	PL-40	24.0	4.0	0.25	14/16	47.8	65.9
Plate 2	PL-40	24.0	4.0	0.25	14/16	47.8	65.9

TEST RESULTS

Failure Type: Bearing/ Tear Out

Failure Load: 21000 lbs/plate

Max Deflection $\Delta_{max}=1.16$ in.

Failure Plate: PL-40

COMMENTS

- * PL-40 yielded at a load of 14200 lbs with a deformation of 0.012 in.
- * Bulging started at a load of 17000 lbs with a deformation of 0.025 in.
- * The connection maintained its strength after yielding point.

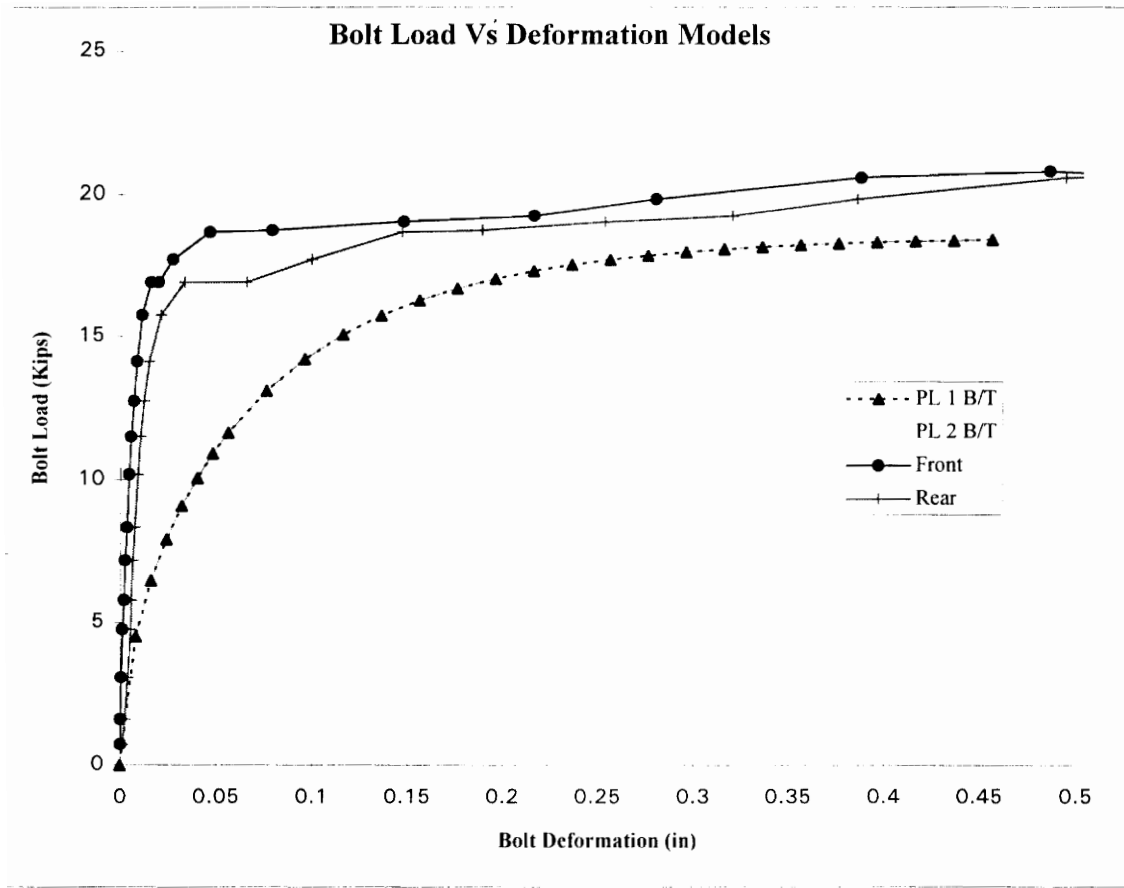

Figure C-66

Plate	tp	Fu	B/T	Bolt	A325
Plate 1	0.25	65.9	18.53	Bolt Dia.	0.75
Plate 2	0.25	65.9	18.53	Fv	72
				Bolt Shear	31.81

Richard Coefficients

K= 0 Kp= 0 Ro= 0
 K1= 0 n= 0

Data Point	Volts	Load	F1	F2	F3	F4	R1	R2	R3	R4	AVG(F)	AVG(R)
1	0.05	0.73	-0.001	-0.001	0.000	0.000	-0.002	-0.003	0.000	0.000	0.000	0.001
2	0.11	1.61	-0.001	-0.001	0.000	0.000	-0.005	-0.006	0.001	0.000	0.000	0.002
3	0.21	3.08	-0.001	-0.001	0.000	0.000	-0.008	-0.009	0.001	0.000	0.001	0.004
4	0.32	4.76	-0.001	-0.001	-0.001	-0.002	-0.010	-0.011	0.000	0.000	0.001	0.005
5	0.39	5.79	-0.001	-0.002	-0.002	-0.003	-0.011	-0.012	0.000	0.000	0.002	0.006
6	0.48	7.18	-0.001	-0.002	-0.003	-0.004	-0.012	-0.014	0.000	0.000	0.003	0.007
7	0.56	8.35	-0.002	-0.003	-0.004	-0.005	-0.013	-0.017	0.000	-0.001	0.004	0.008
8	0.68	10.18	-0.002	-0.004	-0.006	-0.007	-0.015	-0.018	-0.001	-0.002	0.005	0.009
9	0.77	11.50	-0.002	-0.006	-0.007	-0.008	-0.016	-0.021	-0.001	-0.003	0.006	0.010
10	0.85	12.74	-0.003	-0.007	-0.008	-0.010	-0.018	-0.023	-0.002	-0.005	0.007	0.012
11	0.94	14.14	-0.004	-0.008	-0.009	-0.013	-0.021	-0.027	-0.004	-0.007	0.008	0.015
12	1.05	15.76	-0.004	-0.012	-0.010	-0.018	-0.027	-0.033	-0.010	-0.013	0.011	0.021
13	1.13	16.93	-0.004	-0.021	-0.012	-0.026	-0.042	-0.043	-0.024	-0.023	0.016	0.033
14	1.13	16.93	-0.004	-0.028	-0.012	-0.035	-0.077	-0.073	-0.059	-0.053	0.020	0.065
15	1.18	17.73	-0.004	-0.043	-0.011	-0.051	-0.112	-0.106	-0.094	-0.086	0.027	0.100
16	1.25	18.69	-0.006	-0.078	-0.013	-0.087	-0.159	-0.152	-0.142	-0.134	0.046	0.147
17	1.25	18.76	-0.034	-0.116	-0.041	-0.125	-0.202	-0.192	-0.185	-0.176	0.079	0.189
18	1.27	19.05	-0.105	-0.185	-0.111	-0.190	-0.266	-0.256	-0.251	-0.240	0.148	0.253
19	1.28	19.27	-0.174	-0.255	-0.179	-0.258	-0.334	-0.322	-0.318	-0.307	0.216	0.320
20	1.32	19.86	-0.238	-0.318	-0.243	-0.322	-0.400	-0.386	-0.383	-0.373	0.280	0.386
21	1.37	20.59	-0.346	-0.426	-0.350	-0.428	-0.510	-0.495	-0.493	-0.479	0.388	0.494
22	1.39	20.81	-0.444	-0.525	-0.450	-0.525	-0.612	-0.595	-0.595	-0.579	0.486	0.595
23	1.37	20.52	-0.556	-0.638	-0.560	-0.635	-0.734	-0.718	-0.717	-0.700	0.597	0.717

Table C-66

TENSION TESTS ON BOLTED CONNECTIONS

SUMMARY SHEET

Test No: 67

Date: April 9, 1995

Test Designation: 3/8x3/8x3/4

Recorder: Burak Karsu

GEOMETRIC AND MATERIAL PROPERTIES

BOLT

Type:A325

Diameter $d_b=0.75$ in.

Length $L_b=2.0$ in.

Shear Str. $F_v=72$ ksi

Edge Dist. $e=1.125$ in.

Fully Pretensioned--Yes

Bolt Hole Fabr.--Drilled

Bolt Hole Type--Standard

Threads in Shear Plane--X

PLATES

No	Designation	Length (in.)	Width (in.)	Thickness (in.)	Hole Dia. (in.)	Fy (ksi)	Fu (ksi)
Plate 1	PL-25	24.0	5.0	0.375	14/16	43.7	63.7
Plate 2	PL-25	24.0	5.0	0.375	14/16	43.7	63.7

TEST RESULTS

Failure Type: Bearing/ Tear Out

Failure Load: 32000 lbs/plate

Max Deflection $\Delta_{max}=0.90$ in.

Failure Plate:

COMMENTS

* PL-25 yielded at a load of 19000 lbs with a deformation of 0.02 in.

* Bulging started at a load of 23500 lbs with deformation 0.15 in.

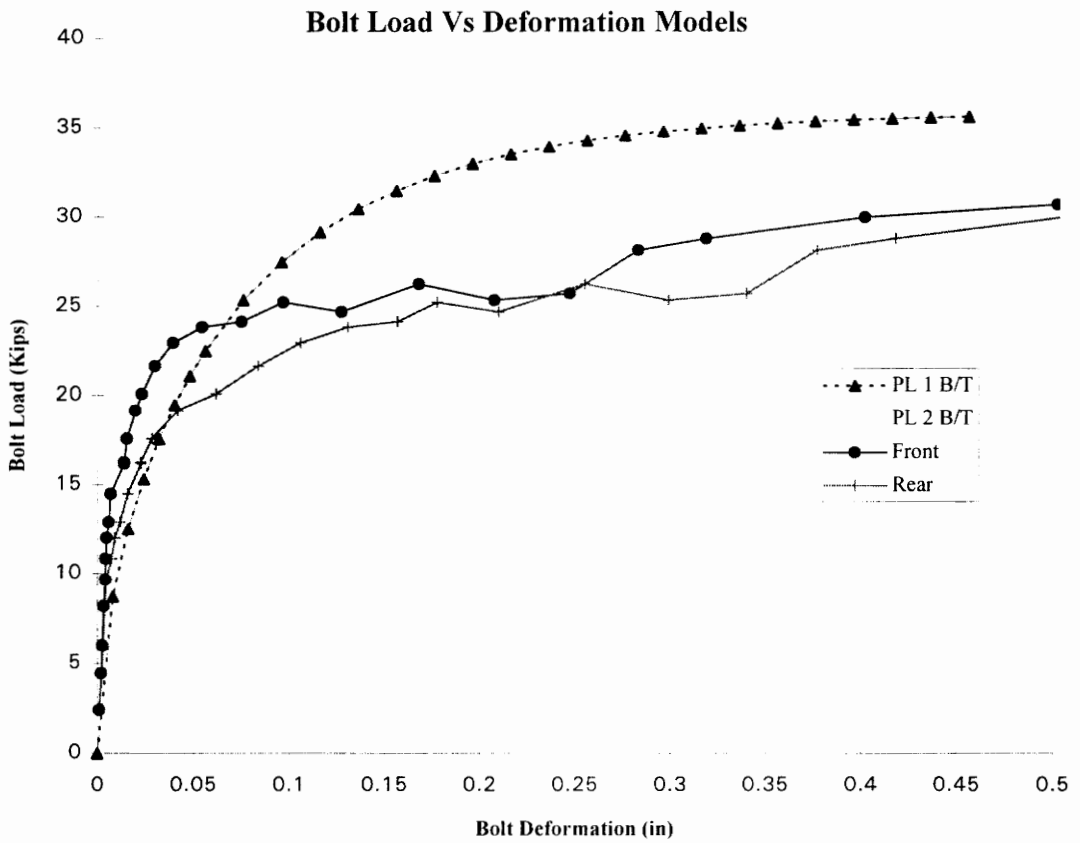

Figure C-67

Plate	tp	Fu	B/T	Bolt	A325
Plate 1	0.375	63.7	35.83	Bolt Dia.	0.75
Plate 2	0.375	63.7	35.83	Fv	72
				Bolt Shear	31.81

Richard Coefficients

K= 0 Kp= 0 Ro= 0
 K1= 0 n= 0

TENSION TESTS ON BOLTED CONNECTIONS

SUMMARY SHEET

Test No: 68

Date: February 17, 1995

Test Designation: 1/4x1/2x3/4

Recorder: Burak Karsu

GEOMETRIC AND MATERIAL PROPERTIES

BOLT

Type:A325

Diameter $d_b=0.75$ in.

Length $L_b=2.0$

Shear Str. $F_v=72$ ksi

Edge Dist. $e=1.125$ in.

Fully Pretensioned--Yes

Bolt Hole Fabr.--Drilled

Bolt Hole Type--Standard

Threads in Shear Plane--X

PLATES

No	Designation	Length (in.)	Width (in.)	Thickness (in.)	Hole Dia. (in.)	Fy (ksi)	Fu (ksi)
Plate 1	PL-40	24.0	4.0	0.25	14/16	47.9	66.9
Plate 2	PL-42	24.0	5.0	0.5	14/16	46.7	70.8

TEST RESULTS

Failure Type: Bearing / Tear Out

Failure Load: 23000 lbs/plate

Max Deflection $\Delta_{max}=0.7$ in.

Failure Plate: PL-40

COMMENTS

* PL-40 yielded at a load of 15000 lbs with 0.015 in. of deformation.

* Bulging started at 0.07 in. on PL-40.

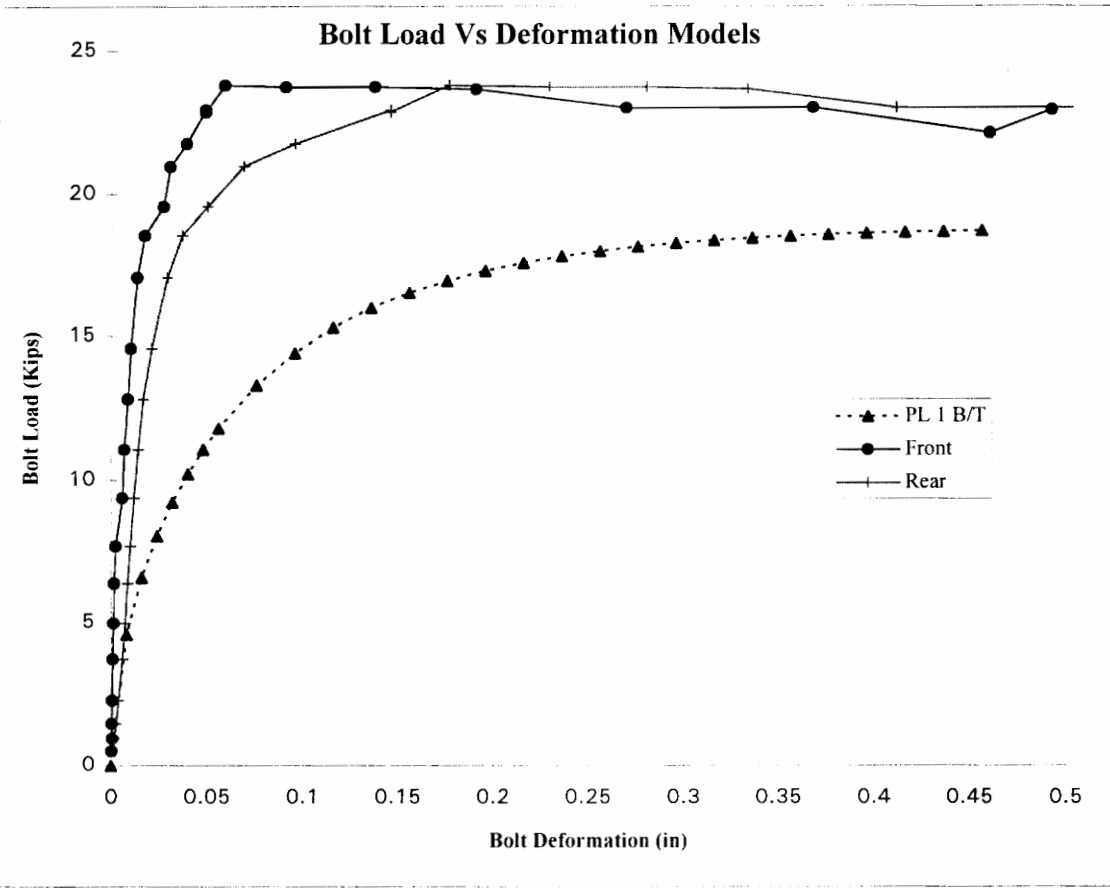

Figure C-68

Plate	tp	Fu	B/T	Bolt	A325
Plate 1	0.25	66.9	18.81	Bolt Dia.	0.75
Plate 2	0.5	70.8	39.82	Fv	72
				Bolt Shear	31.81

Richard Coefficients

K= 0 Kp= 0 Ro= 0
 K1= 0 n= 0

Data Point	Volts	Load	F1	F2	F3	F4	R1	R2	R3	R4	AVG(F)	AVG(R)
1	0.03	0.51	0.000	0.000	-0.001	-0.001	-0.002	-0.001	0.000	0.001	0.000	0.001
2	0.06	0.95	-0.001	0.000	-0.001	-0.001	-0.005	-0.003	0.000	0.002	0.001	0.002
3	0.10	1.46	-0.001	0.000	-0.001	-0.001	-0.006	-0.006	0.000	0.002	0.000	0.002
4	0.15	2.27	-0.001	-0.001	-0.001	-0.001	-0.009	-0.009	0.000	0.002	0.001	0.004
5	0.25	3.74	-0.001	-0.002	-0.001	-0.001	-0.014	-0.014	0.001	0.003	0.001	0.006
6	0.33	4.98	-0.002	-0.002	-0.001	-0.001	-0.016	-0.017	0.001	0.003	0.001	0.007
7	0.42	6.37	-0.001	-0.002	-0.001	-0.002	-0.019	-0.020	0.002	0.002	0.002	0.009
8	0.51	7.69	0.000	-0.002	-0.003	-0.005	-0.020	-0.023	0.002	0.000	0.003	0.010
9	0.63	9.38	-0.006	-0.003	-0.006	-0.009	-0.021	-0.028	0.003	-0.002	0.006	0.012
10	0.74	11.06	-0.006	-0.004	-0.007	-0.011	-0.022	-0.034	0.004	-0.006	0.007	0.014
11	0.85	12.82	-0.005	-0.005	-0.010	-0.015	-0.023	-0.039	0.006	-0.010	0.009	0.017
12	0.97	14.58	-0.003	-0.006	-0.012	-0.020	-0.026	-0.048	0.005	-0.015	0.010	0.021
13	1.14	17.07	-0.001	-0.011	-0.013	-0.029	-0.035	-0.059	0.000	-0.024	0.014	0.029
14	1.24	18.54	-0.003	-0.016	-0.014	-0.037	-0.044	-0.067	-0.006	-0.031	0.017	0.037
15	1.30	19.56	-0.006	-0.029	-0.019	-0.054	-0.057	-0.080	-0.023	-0.040	0.027	0.050
16	1.40	20.96	-0.003	-0.035	-0.020	-0.064	-0.078	-0.098	-0.043	-0.058	0.031	0.069
17	1.45	21.76	-0.005	-0.048	-0.024	-0.080	-0.106	-0.122	-0.073	-0.082	0.039	0.096
18	1.53	22.93	-0.003	-0.064	-0.028	-0.102	-0.156	-0.172	-0.123	-0.131	0.049	0.146
19	1.52	22.86	-0.003	-0.064	-0.028	-0.102	-0.156	-0.172	-0.123	-0.131	0.049	0.146
20	1.59	23.81	-0.007	-0.077	-0.035	-0.118	-0.188	-0.204	-0.153	-0.162	0.059	0.177
21	1.58	23.74	-0.032	-0.113	-0.063	-0.157	-0.240	-0.257	-0.206	-0.214	0.091	0.229
22	1.58	23.74	-0.076	-0.160	-0.109	-0.205	-0.292	-0.308	-0.256	-0.265	0.137	0.280
23	1.58	23.67	-0.128	-0.212	-0.163	-0.260	-0.345	-0.363	-0.308	-0.317	0.191	0.333
24	1.53	23.01	-0.205	-0.292	-0.241	-0.341	-0.423	-0.442	-0.386	-0.394	0.270	0.411
25	1.53	23.01	-0.302	-0.390	-0.339	-0.440	-0.523	-0.542	-0.484	-0.492	0.368	0.511
26	1.48	22.13	-0.394	-0.481	-0.432	-0.533	-0.616	-0.635	-0.576	-0.584	0.460	0.603
27	1.53	22.93	-0.424	-0.513	-0.464	-0.566	-0.650	-0.672	-0.612	-0.620	0.492	0.639
28	0.43	6.45	-0.440	-0.519	-0.481	-0.569	-0.828	-0.808	-0.823	-0.790	0.503	0.812

Table C-68

TENSION TESTS ON BOLTED CONNECTIONS

SUMMARY SHEET

Test No: 69

Date: April 10, 1995

Test Designation: 1/2x1/2x3/4

Recorder: Burak Karsu

GEOMETRIC AND MATERIAL PROPERTIES

BOLT

Type: A325

Diameter $d_b=0.75$ in.

Length $L_b=2.25$ in.

Shear Str. $F_v=72$ ksi

Edge Dist. $e=1.125$ in.

Fully Pretensioned--Yes

Bolt Hole Fabr.--Drilled

Bolt Hole Type--Standard

Threads in Shear Plane--X

PLATES

No	Designation	Length (in.)	Width (in.)	Thickness (in.)	Hole Dia. (in.)	Fy (ksi)	Fu (ksi)
Plate 1	PL-42	24.0	5.0	0.5	14/16	46.7	70.8
Plate 2	PL-42	24.0	5.0	0.5	14/16	46.7	70.8

TEST RESULTS

Failure Type: Bolt Shear

Failure Load: 33000 lbs/bolt

Max Deflection $\Delta_{max}=0.5$ in.

Failure Plate: N/A

COMMENTS

* PL-42 yielded at 0.02 in. of deformation with 21000 lbs.

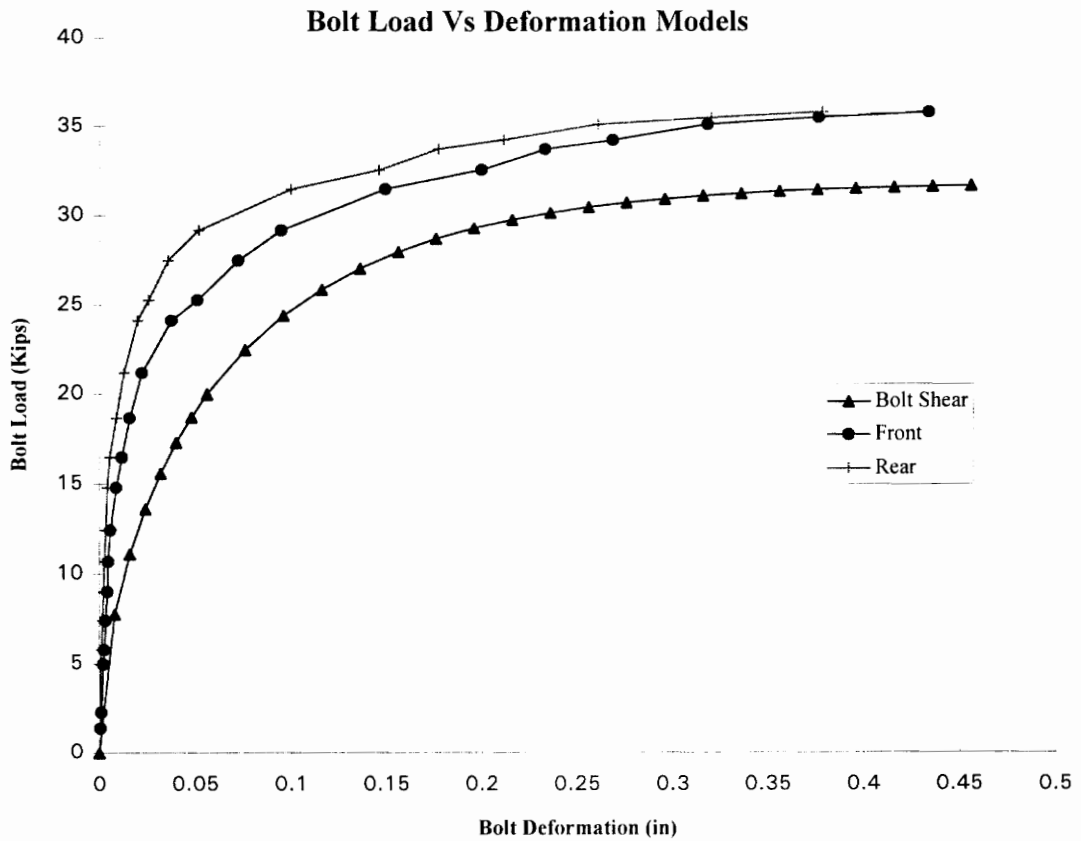

Figure C-69

Plate	tp	Fu	B/T	Bolt	A325
Plate 1	0.5	70.8	39.83	Bolt Dia.	0.75
Plate 2	0.5	70.8	39.83	Fv	72
				Bolt Shear	31.81

Richard Coefficients

K= 0 Kp= 0 Ro= 0
 K1= 0 n= 0

Data Point	Volts	Load	F1	F2	F3	F4	R1	R2	R3	R4	AVG(F)	AVG(R)
1	0.09	1.39	-0.001	-0.001	-0.001	-0.001	-0.001	-0.001	-0.001	0.000	0.001	0.001
2	0.15	2.27	-0.001	-0.001	-0.002	-0.002	-0.001	0.000	-0.001	0.000	0.001	0.000
3	0.33	4.98	-0.001	-0.001	-0.004	-0.003	-0.001	-0.001	-0.001	-0.001	0.002	0.001
4	0.33	4.98	-0.001	-0.001	-0.004	-0.003	-0.001	-0.001	-0.001	-0.001	0.002	0.001
5	0.39	5.79	-0.002	-0.001	-0.004	-0.004	-0.002	-0.001	-0.001	-0.001	0.003	0.001
6	0.49	7.40	-0.002	-0.002	-0.005	-0.005	-0.002	-0.002	-0.002	-0.001	0.003	0.002
7	0.60	9.00	-0.003	-0.002	-0.006	-0.006	-0.003	-0.002	-0.002	-0.001	0.004	0.002
8	0.71	10.69	-0.003	-0.002	-0.007	-0.006	-0.004	-0.004	-0.002	-0.001	0.005	0.003
9	0.83	12.45	-0.005	-0.003	-0.009	-0.007	-0.005	-0.004	-0.002	-0.002	0.006	0.004
10	0.99	14.80	-0.009	-0.004	-0.014	-0.009	-0.007	-0.006	-0.002	-0.002	0.009	0.004
11	1.10	16.49	-0.013	-0.006	-0.018	-0.011	-0.008	-0.008	-0.003	-0.002	0.012	0.005
12	1.25	18.68	-0.018	-0.009	-0.023	-0.014	-0.010	-0.013	-0.005	-0.007	0.016	0.009
13	1.41	21.18	-0.024	-0.015	-0.029	-0.021	-0.015	-0.018	-0.008	-0.011	0.022	0.013
14	1.61	24.11	-0.036	-0.034	-0.042	-0.039	-0.022	-0.026	-0.013	-0.018	0.038	0.020
15	1.69	25.28	-0.048	-0.050	-0.053	-0.053	-0.027	-0.032	-0.019	-0.023	0.051	0.026
16	1.83	27.47	-0.067	-0.073	-0.072	-0.077	-0.038	-0.044	-0.028	-0.033	0.072	0.036
17	1.94	29.16	-0.088	-0.098	-0.093	-0.100	-0.056	-0.061	-0.043	-0.048	0.095	0.052
18	2.10	31.44	-0.141	-0.156	-0.144	-0.156	-0.104	-0.109	-0.090	-0.096	0.149	0.100
19	2.17	32.53	-0.190	-0.208	-0.194	-0.208	-0.150	-0.155	-0.136	-0.142	0.200	0.146
20	2.25	33.70	-0.222	-0.242	-0.227	-0.242	-0.181	-0.188	-0.167	-0.173	0.233	0.177
21	2.28	34.21	-0.257	-0.278	-0.262	-0.278	-0.215	-0.222	-0.201	-0.208	0.269	0.211
22	2.34	35.09	-0.307	-0.328	-0.311	-0.328	-0.266	-0.272	-0.250	-0.256	0.318	0.261
23	2.36	35.46	-0.364	-0.386	-0.369	-0.388	-0.325	-0.331	-0.310	-0.315	0.377	0.320
24	2.38	35.76	-0.421	-0.443	-0.426	-0.446	-0.382	-0.390	-0.369	-0.374	0.434	0.378

Table C-69

TENSION TESTS ON BOLTED CONNECTIONS

SUMMARY SHEET

Test No: 70

Date: April 10, 1995

Test Designation: 1/4x5/8x3/4

Recorder: Burak Karsu

GEOMETRIC AND MATERIAL PROPERTIES

BOLT

Type: A325 Diameter $d_b=0.75$ in. Length $L_b=2.5$ in.

Shear Str. $F_v=72$ ksi Edge Dist. $e=1.125$ in. Fully Pretensioned--Yes

Bolt Hole Fabr.--Drilled Bolt Hole Type--Standard

Threads in Shear Plane--X

PLATES

<u>No</u>	<u>Designation</u>	<u>Length (in.)</u>	<u>Width (in.)</u>	<u>Thickness (in.)</u>	<u>Hole Dia. (in.)</u>	<u>Fy (ksi)</u>	<u>Fu (ksi)</u>
Plate 1	PL-41	24.0	5.0	0.25	14/16	47.8	67.5
Plate 2	PL-43	24.0	5.0	0.625	14/16	43.7	63.3

TEST RESULTS

Failure Type: Bolt Shear

Failure Load: 21500 lbs/bolt

Max Deflection $\Delta_{max}=0.66$ in.

Failure Plate: N/A

COMMENTS

* At 26000 lbs, PL-41 yielded with 0.025 in. of deformation.

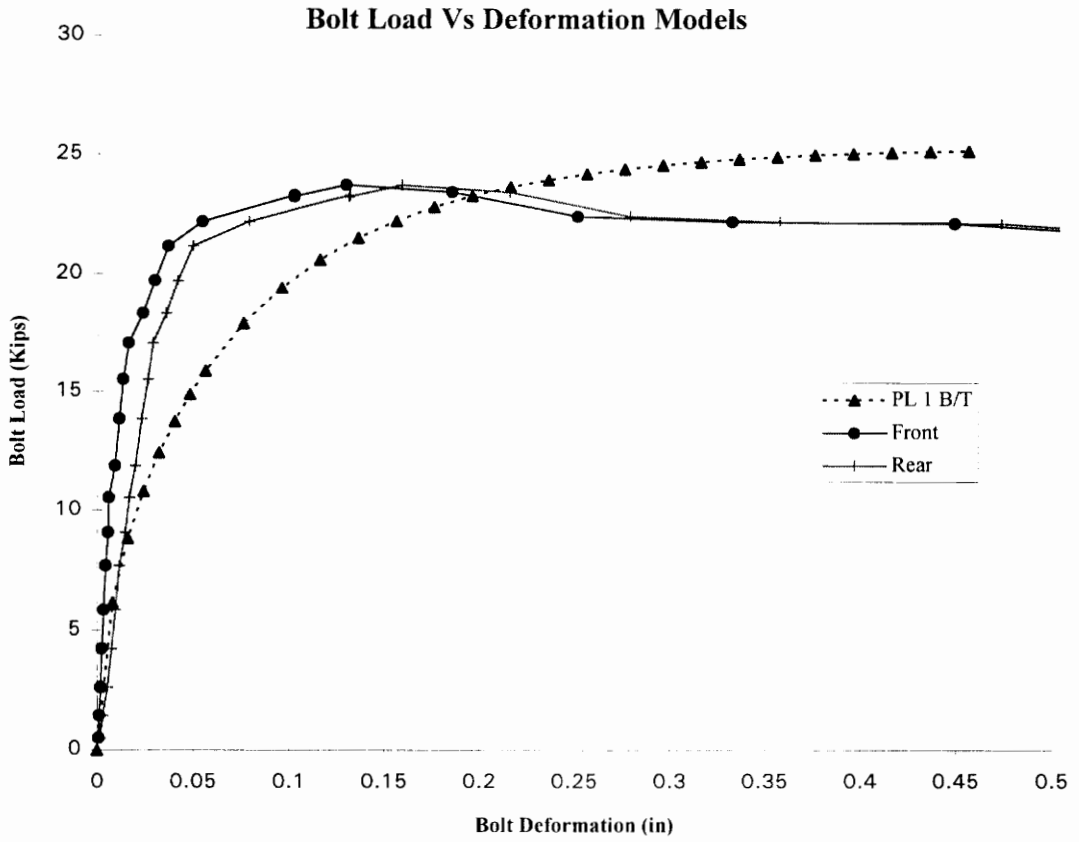

Figure C-70

Plate				Bolt	A325
	tp	Fu	B/T	Bolt Dia.	0.75
Plate 1	0.25	67.5	25.31	Fv	72
Plate 2	625	63.3	53.20	Bolt Shear	31.81

Richard Coefficients

K= 0 Kp= 0 Ro= 0
 K1= 0 n= 0

Data Point	Volts	Load	F1	F2	F3	F4	R1	R2	R3	R4	AVG(F)	AVG(R)
1	0.03	0.50	-0.001	-0.001	-0.001	-0.001	-0.003	-0.003	-0.001	0.000	0.001	0.002
2	0.10	1.46	0.000	-0.001	-0.001	-0.002	-0.005	-0.007	0.000	0.001	0.001	0.003
3	0.18	2.63	0.000	-0.001	-0.003	-0.003	-0.012	-0.014	0.002	0.002	0.002	0.005
4	0.28	4.25	0.000	-0.001	-0.004	-0.005	-0.018	-0.020	0.004	0.004	0.003	0.008
5	0.39	5.86	0.000	-0.002	-0.006	-0.007	-0.024	-0.026	0.006	0.006	0.004	0.010
6	0.51	7.69	0.000	-0.002	-0.007	-0.009	-0.029	-0.031	0.007	0.007	0.005	0.012
7	0.61	9.08	0.000	-0.003	-0.009	-0.011	-0.035	-0.038	0.008	0.007	0.006	0.015
8	0.70	10.55	0.001	-0.004	-0.009	-0.013	-0.040	-0.044	0.010	0.007	0.006	0.017
9	0.79	11.87	-0.006	-0.005	-0.010	-0.015	-0.046	-0.051	0.011	0.007	0.009	0.020
10	0.92	13.85	-0.008	-0.006	-0.012	-0.018	-0.052	-0.059	0.013	0.007	0.011	0.023
11	1.04	15.53	-0.009	-0.007	-0.014	-0.022	-0.058	-0.066	0.014	0.006	0.013	0.026
12	1.14	17.07	-0.013	-0.009	-0.017	-0.026	-0.062	-0.072	0.015	0.005	0.016	0.029
13	1.22	18.31	-0.020	-0.016	-0.023	-0.035	-0.071	-0.080	0.007	0.001	0.023	0.036
14	1.31	19.71	-0.024	-0.023	-0.028	-0.045	-0.079	-0.087	0.002	-0.002	0.030	0.042
15	1.41	21.18	-0.028	-0.031	-0.032	-0.056	-0.092	-0.097	-0.004	-0.005	0.037	0.050
16	1.48	22.20	-0.042	-0.049	-0.048	-0.079	-0.125	-0.127	-0.032	-0.031	0.054	0.079
17	1.55	23.30	-0.113	-0.091	-0.083	-0.124	-0.180	-0.183	-0.083	-0.081	0.103	0.132
18	1.55	23.23	-0.113	-0.091	-0.083	-0.124	-0.179	-0.183	-0.083	-0.080	0.102	0.131
19	1.58	23.74	-0.138	-0.118	-0.109	-0.153	-0.208	-0.212	-0.109	-0.106	0.130	0.159
20	1.56	23.45	-0.193	-0.174	-0.165	-0.209	-0.266	-0.269	-0.166	-0.161	0.185	0.216
21	1.49	22.42	-0.259	-0.241	-0.230	-0.275	-0.329	-0.333	-0.228	-0.225	0.251	0.279
22	1.48	22.20	-0.341	-0.321	-0.311	-0.356	-0.409	-0.412	-0.306	-0.303	0.333	0.357
23	1.48	22.13	-0.456	-0.438	-0.428	-0.474	-0.525	-0.530	-0.421	-0.416	0.449	0.473
24	1.44	21.54	-0.574	-0.555	-0.546	-0.592	-0.641	-0.646	-0.535	-0.530	0.567	0.588
25	1.44	21.54	-0.574	-0.555	-0.546	-0.592	-0.641	-0.646	-0.535	-0.531	0.567	0.588
26	1.39	20.78	-0.647	-0.629	-0.621	-0.670	-0.730	-0.739	-0.631	-0.626	0.642	0.681

Table C-70

TENSION TESTS ON BOLTED CONNECTIONS

SUMMARY SHEET

Test No: 71

Date: April 10, 1995

Test Designation: 5/8x5/8x3/4

Recorder: Burak Karsu

GEOMETRIC AND MATERIAL PROPERTIES

BOLT

Type:A325 Diameter $d_b=0.75$ in. Length $L_b= 2.25$ in.

Shear Str. $F_v=72$ ksi Edge Dist. $e=1.125$ in. Fully Pretensioned--Yes

Bolt Hole Fabr.--Drilled

Bolt Hole Type--Standard

Threads in Shear Plane--X

PLATES

<u>No</u>	<u>Designation</u>	<u>Length</u> <u>(in.)</u>	<u>Width</u> <u>(in.)</u>	<u>Thickness</u> <u>(in.)</u>	<u>Hole Dia.</u> <u>(in.)</u>	<u>Fy</u> <u>(ksi)</u>	<u>Fu</u> <u>(ksi)</u>
Plate 1	PL-43	24.0	5.0	0.625	14/16	43.7	63.3
Plate 2	PL-43	24.0	5.0	0.625	14/16	43.7	63.3

TEST RESULTS

Failure Type: Bolt Shear

Failure Load: 40000 lbs/plate

Max Deflection $\Delta_{max}=0.7$ in.

Failure Plate:

COMMENTS

* PL-43 yielded at 21000 lbs with 0.025 in. of deformation.

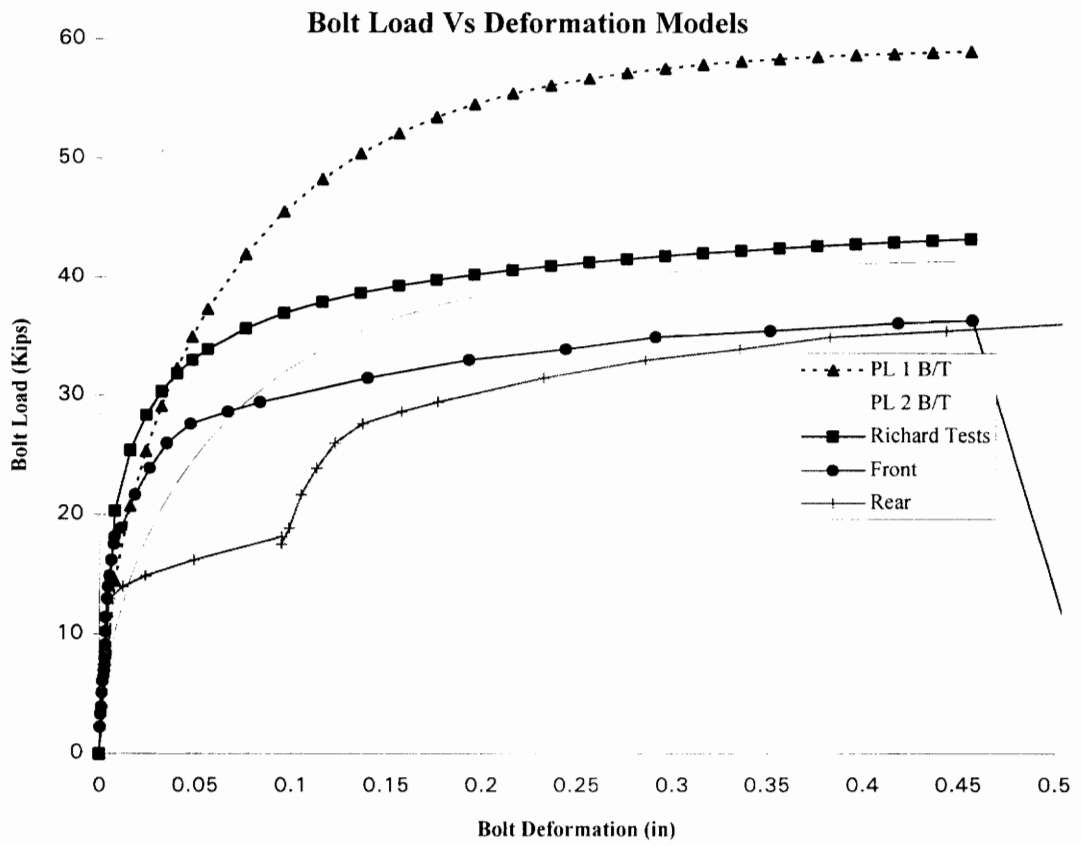

Figure C-71

Plate	tp	Fu	B/T	Bolt	A325
Plate 1	0.625	63.3	59.30	Bolt Dia.	0.75
Plate 2	0.625	63.3	59.30	Fv	72
				Bolt Shear	31.8

Richard Coefficients

K= 10875 Kp= 0 Ro= 50
 K1= 19313 n= 0.5

Data Point	Volts	Load	F1	F2	F3	F4	R1	R2	R3	R4	AVG(F)	AVG(R)
1	0.00	0.00	-0.001	-0.001	0.000	0.000	-0.001	0.000	0.000	0.000	0.000	0.000
2	0.04	0.59	-0.001	0.000	0.000	-0.001	-0.003	-0.003	0.000	0.001	0.000	0.001
3	0.08	1.25	-0.001	0.000	-0.002	-0.002	-0.005	-0.004	0.000	0.001	0.001	0.002
4	0.16	2.34	-0.001	0.001	-0.004	-0.004	-0.008	-0.006	0.000	0.001	0.002	0.003
5	0.30	4.47	-0.001	0.001	-0.007	-0.007	-0.012	-0.010	0.000	0.001	0.004	0.005
6	0.54	8.07	0.000	0.001	-0.012	-0.012	-0.017	-0.017	0.000	0.001	0.006	0.008
7	0.65	9.75	0.000	0.001	-0.014	-0.015	-0.021	-0.019	0.000	0.001	0.007	0.010
8	0.84	12.61	0.001	0.000	-0.017	-0.020	-0.024	-0.024	0.000	0.001	0.009	0.012
9	1.01	15.10	0.001	-0.001	-0.020	-0.024	-0.028	-0.028	0.000	0.001	0.011	0.014
10	1.16	17.44	0.002	-0.003	-0.022	-0.030	-0.034	-0.034	-0.001	-0.001	0.013	0.017
11	1.29	19.35	0.002	-0.008	-0.025	-0.038	-0.042	-0.039	-0.006	-0.004	0.017	0.022
12	1.39	20.81	0.002	-0.015	-0.028	-0.050	-0.054	-0.046	-0.013	-0.009	0.023	0.031
13	1.40	21.03	-0.011	-0.042	-0.046	-0.079	-0.072	-0.062	-0.029	-0.021	0.044	0.046
14	1.41	21.10	-0.026	-0.058	-0.062	-0.097	-0.092	-0.081	-0.049	-0.041	0.061	0.066
15	1.43	21.47	-0.048	-0.084	-0.088	-0.128	-0.122	-0.110	-0.078	-0.067	0.087	0.094
16	1.45	21.76	-0.096	-0.135	-0.137	-0.180	-0.177	-0.161	-0.130	-0.118	0.137	0.146
17	1.46	21.84	-0.155	-0.195	-0.198	-0.240	-0.237	-0.223	-0.192	-0.178	0.197	0.208
18	1.44	21.54	-0.226	-0.265	-0.270	-0.312	-0.308	-0.295	-0.265	-0.252	0.268	0.280
19	1.39	20.88	-0.328	-0.368	-0.372	-0.413	-0.410	-0.398	-0.364	-0.352	0.370	0.381
20	1.43	21.40	-0.421	-0.459	-0.465	-0.506	-0.501	-0.492	-0.457	-0.445	0.463	0.474
21	1.41	21.10	-0.486	-0.524	-0.532	-0.569	-0.568	-0.558	-0.523	-0.511	0.528	0.540
22	1.21	18.17	-0.611	-0.650	-0.646	-0.686	-0.630	-0.622	-0.578	-0.568	0.648	0.599

Table C-71

TENSION TESTS ON BOLTED CONNECTIONS

SUMMARY SHEET

Test No: 72

Date: April 11, 1995

Test Designation: 1/4x1/4x7/8

Recorder: Burak Karsu

GEOMETRIC AND MATERIAL PROPERTIES

BOLT

Type:A325

Diameter $d_b=0.875$ in.

Length $L_b= 2.0$ in.

Shear Str. $F_v=72$ ksi

Edge Dist. $e=1.312$ in.

Fully Pretensioned--Yes

Bolt Hole Fabr.--Drilled

Bolt Hole Type--Standard

Threads in Shear Plane--X

PLATES

No	Designation	Length (in.)	Width (in.)	Thickness (in.)	Hole Dia. (in.)	Fy (ksi)	Fu (ksi)
Plate 1	PL-41	24.0	5.0	0.25	14/16	47.8	67.5
Plate 2	PL-44	24.0	5.0	0.25	14/16	44.5	67.8

TEST RESULTS

Failure Type: Bearing/Tear Out

Failure Load: 25000 lbs/plate

Max Deflection $\Delta_{max}=1.1$ in.

Failure Plate: PL-41

COMMENTS

* PL-41 yielded at 0.02 in of deformation with 20000 lbs.

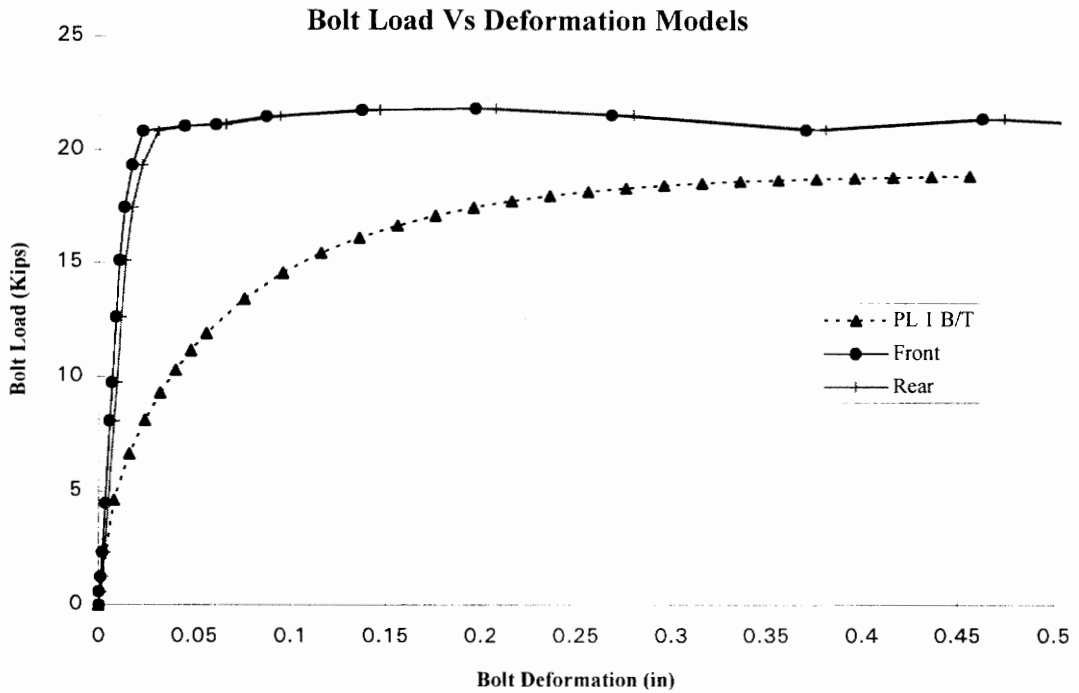

Figure C-72

Plate	tp	Fu	B/T	Bolt	A325
Plate 1	0.25	67.5	18.98	Bolt Dia.	0.75
Plate 2	0.25	67.8	19.10	Fv	72
				Bolt Shear	31.81

Richard Coefficients

$K = 0$ $K_p = 0$ $R_o = 0$
 $K_1 = 0$ $n = 0$

Data Point	Volts	Load	F1	F2	F3	F4	R1	R2	R3	R4	AVG(F)	AVG(R)
1	0.09	2.02	-0.001	0.000	-0.001	-0.001	-0.002	-0.002	-0.001	0.000	0.000	0.001
2	0.21	3.92	-0.001	-0.001	-0.001	-0.002	-0.005	-0.005	0.000	0.000	0.001	0.003
3	0.34	5.75	-0.002	-0.001	-0.002	-0.004	-0.008	-0.008	-0.001	0.000	0.002	0.004
4	0.40	6.71	-0.002	-0.001	-0.003	-0.005	-0.009	-0.010	-0.001	-0.001	0.003	0.005
5	0.48	7.88	-0.004	-0.001	-0.004	-0.005	-0.010	-0.011	-0.002	-0.001	0.004	0.006
6	0.63	10.08	-0.006	-0.001	-0.007	-0.006	-0.012	-0.015	-0.002	-0.002	0.005	0.008
7	0.73	11.69	-0.008	-0.001	-0.010	-0.006	-0.013	-0.017	-0.003	-0.004	0.006	0.009
8	0.85	13.52	-0.012	0.000	-0.013	-0.006	-0.015	-0.020	-0.004	-0.005	0.008	0.011
9	0.97	15.20	-0.015	0.000	-0.017	-0.007	-0.015	-0.024	-0.004	-0.008	0.010	0.013
10	1.09	17.04	-0.020	0.000	-0.021	-0.007	-0.016	-0.030	-0.005	-0.012	0.012	0.016
11	1.26	19.61	-0.026	-0.002	-0.029	-0.010	-0.017	-0.037	-0.005	-0.020	0.017	0.020
12	1.38	21.44	-0.035	-0.007	-0.037	-0.017	-0.021	-0.046	-0.009	-0.028	0.024	0.026
13	1.48	22.83	-0.046	-0.020	-0.050	-0.029	-0.030	-0.056	-0.017	-0.037	0.036	0.035
14	1.49	23.05	-0.075	-0.050	-0.079	-0.060	-0.057	-0.085	-0.046	-0.068	0.066	0.064
15	1.48	22.89	-0.104	-0.080	-0.107	-0.089	-0.084	-0.112	-0.074	-0.095	0.095	0.091
16	1.45	22.46	-0.158	-0.134	-0.161	-0.145	-0.139	-0.168	-0.130	-0.152	0.150	0.147
17	1.46	22.61	-0.213	-0.189	-0.215	-0.201	-0.195	-0.225	-0.186	-0.210	0.204	0.204
18	1.46	22.61	-0.264	-0.241	-0.266	-0.251	-0.247	-0.276	-0.238	-0.262	0.256	0.256
19	1.48	22.83	-0.347	-0.325	-0.350	-0.336	-0.331	-0.361	-0.324	-0.345	0.340	0.340
20	1.47	22.76	-0.428	-0.403	-0.431	-0.414	-0.412	-0.443	-0.405	-0.429	0.419	0.422
21	1.53	23.63	-0.531	-0.508	-0.535	-0.520	-0.518	-0.551	-0.512	-0.535	0.524	0.529
22	1.54	23.85	-0.613	-0.589	-0.616	-0.602	-0.602	-0.633	-0.597	-0.621	0.605	0.613
23	1.56	24.15	-0.711	-0.687	-0.715	-0.702	-0.701	-0.733	-0.696	-0.720	0.704	0.713
24	1.59	24.51	-0.814	-0.792	-0.821	-0.807	-0.803	-0.838	-0.803	-0.826	0.808	0.818
25	1.58	24.44	-0.906	-0.882	-0.913	-0.900	-0.889	-0.925	-0.895	-0.916	0.900	0.906
26	1.59	24.59	-0.982	-0.956	-0.989	-0.972	-0.963	-0.997	-0.968	-0.989	0.975	0.979
27	0.81	12.91	-1.127	-1.101	-1.136	-1.120	-1.241	-1.259	-1.258	-1.276	1.121	1.259

Table C-72

TENSION TESTS ON BOLTED CONNECTIONS

SUMMARY SHEET

Test No: 73

Date: April 11, 1995

Test Designation: 1/4x5/8x3/4

Recorder: Burak Karsu

GEOMETRIC AND MATERIAL PROPERTIES

BOLT

Type:A325

Diameter $d_b=0.875$ in.

Length $L_b= 2.25$ in.

Shear Str. $F_v=72$ ksi

Edge Dist. $e=1.375$ in.

Fully Pretensioned--Yes

Bolt Hole Fabr.--Drilled

Bolt Hole Type--Standard

Threads in Shear Plane--X

PLATES

No	Designation	Length (in.)	Width (in.)	Thickness (in.)	Hole Dia. (in.)	Fy (ksi)	Fu (ksi)
Plate 1	PL-43	24.0	5.0	0.25	14/16	47.8	67.5
Plate 2	PL-41	24.0	5.0	0.625	14/16	43.7	63.3

TEST RESULTS

Failure Type: Bearing/ Tear out

Failure Load: 25800 lbs/bolt

Max Deflection $\Delta_{max}=0.38$ in.

Failure Plate: N/A

COMMENTS

* PL-43 yielded at 0.02 in. of deformation with 21000 lbs.

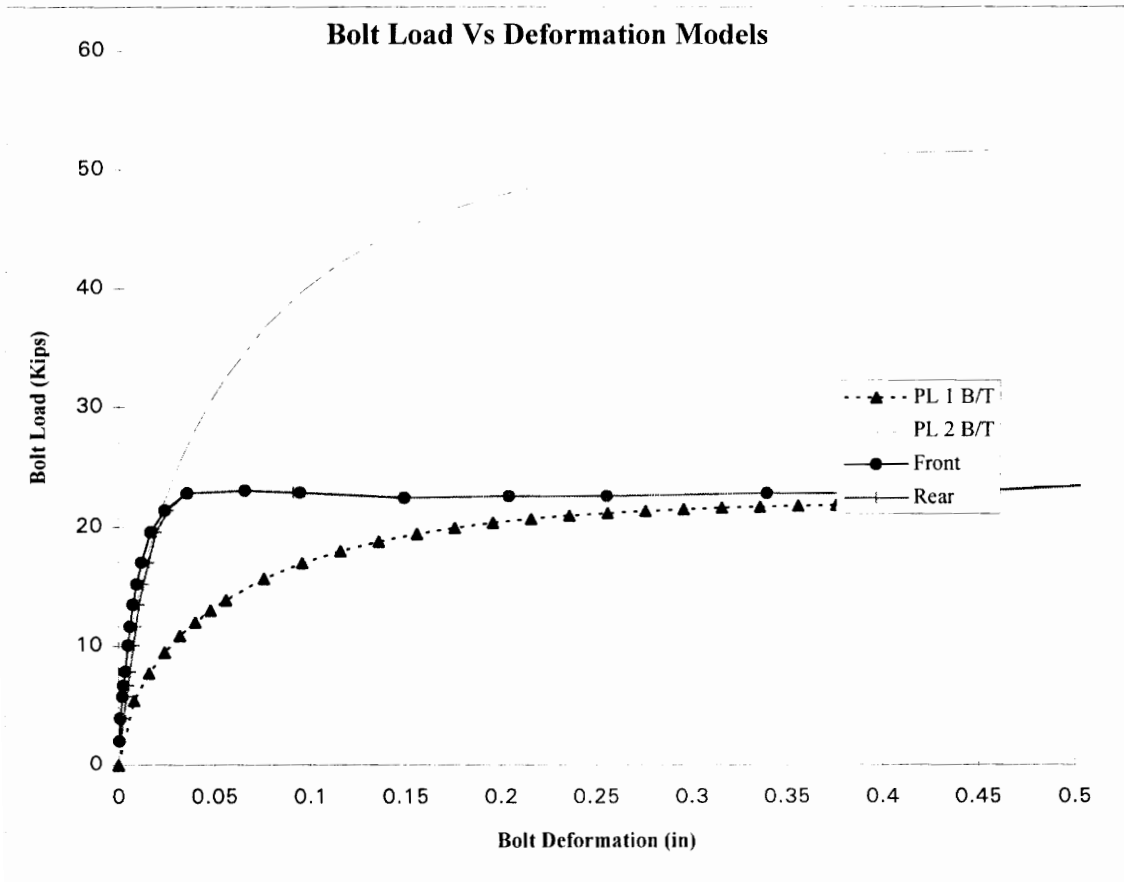

Figure C-73

Plate	tp	Fu	B/T	Bolt	A325
Plate 1	0.25	67.5	22.15	Bolt Dia.	0.875
Plate 2	0.625	63.3	51.90	Fv	72
				Bolt Shear	43.29

Richard Coefficients

K= 0 Kp= 0 Ro= 0
 K1= 0 n= 0

Data Point	Volts	Load	F1	F2	F3	F4	R1	R2	R3	R4	AVG(F)	AVG(R)
1	0.029	0.439	-0.001	-0.001	0.000	0.000	-0.001	0.000	0.000	-0.001	0.000	0.000
2	0.103	1.538	-0.001	-0.001	-0.001	-0.001	-0.002	0.000	0.000	-0.001	0.001	0.001
3	0.381	5.713	-0.002	-0.001	-0.003	-0.002	-0.004	-0.001	-0.001	-0.002	0.002	0.002
4	0.518	7.773	-0.003	-0.001	-0.004	-0.002	-0.004	-0.002	-0.001	-0.002	0.003	0.002
5	0.665	9.970	-0.004	-0.001	-0.006	-0.003	-0.005	-0.002	-0.002	-0.002	0.003	0.003
6	0.811	12.167	-0.006	-0.001	-0.007	-0.004	-0.006	-0.002	-0.002	-0.002	0.004	0.003
7	1.153	17.294	-0.015	0.002	-0.015	-0.002	-0.011	-0.003	-0.007	-0.002	0.007	0.006
8	1.319	19.785	-0.028	0.004	-0.028	0.001	-0.020	-0.002	-0.018	-0.001	0.013	0.010
9	1.475	22.128	-0.036	0.006	-0.035	0.002	-0.029	-0.002	-0.028	-0.001	0.016	0.015
10	1.548	23.227	-0.044	0.007	-0.043	0.004	-0.035	-0.001	-0.033	0.000	0.019	0.017
11	1.724	25.864	-0.058	0.010	-0.057	0.006	-0.049	0.001	-0.046	0.002	0.025	0.023

Table C-73

VITA

Burak Karsu was born in Bolu, Turkey on 10th of April 1971. In 1989, he graduated from Kadikoy Anatolian High School. He graduated with his Bachelor of Science Degree in Civil Engineering from Istanbul Technical University in June 1993. He worked for several engineering firms as an intern. In the fall 1993, he entered the Charles Edward Via, Jr. Department of Civil Engineering in pursuit of Master of Science degree in Civil Engineering in Fall of 1995.

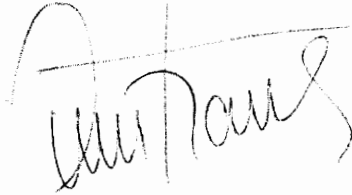
A handwritten signature in black ink, appearing to read "Burak Karsu". The signature is stylized with a large initial 'B' and a horizontal line crossing through the middle of the name.