

Structure

The structure for the project was developed using architectural elements of strong presence.
Seeking to reveal the interaction between structure and nature is the second approach.

DESIGN OF STRUCTURAL SYSTEMS

Two structural systems are designed in this project. The first is the steel truss system serving the 420-foot-long bridge; the second is the structure of the volumes containing the building's secondary functions.

The rectangular bridge is defined by steel truss, enclosed in a glass skin. The transparent bridge contrasts with the opaque elliptical volumes.

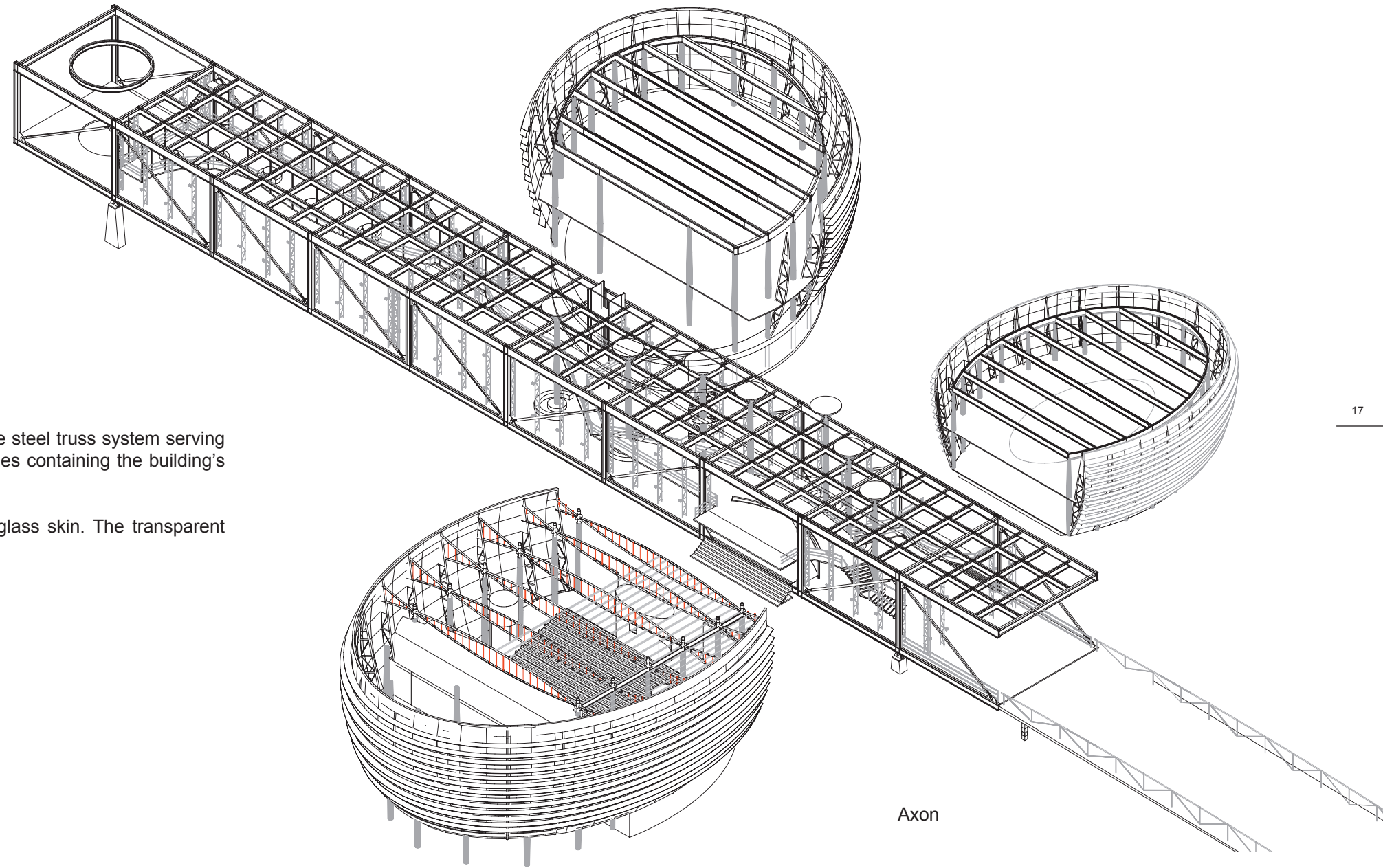

a. Primary Structure - Truss System

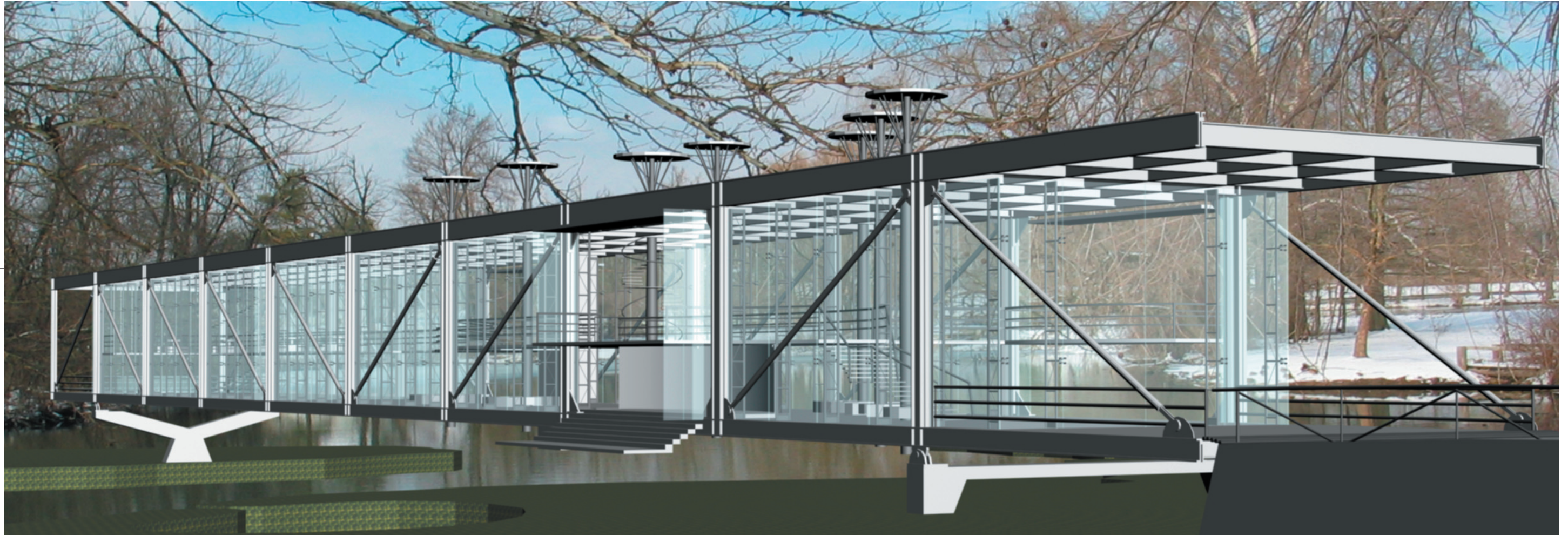

The panels of the truss, with their carefully proportioned, regular geometry, create an intervening structural layer between inside and outside, providing a contrasting frame for the irregular natural landscape of the duckpond.

The span of the truss is 420 feet long. Top and bottom chords and compression members are steel double channel sections; tension members are steel cables. The truss is composed of 10 panels, each 42'x30'.

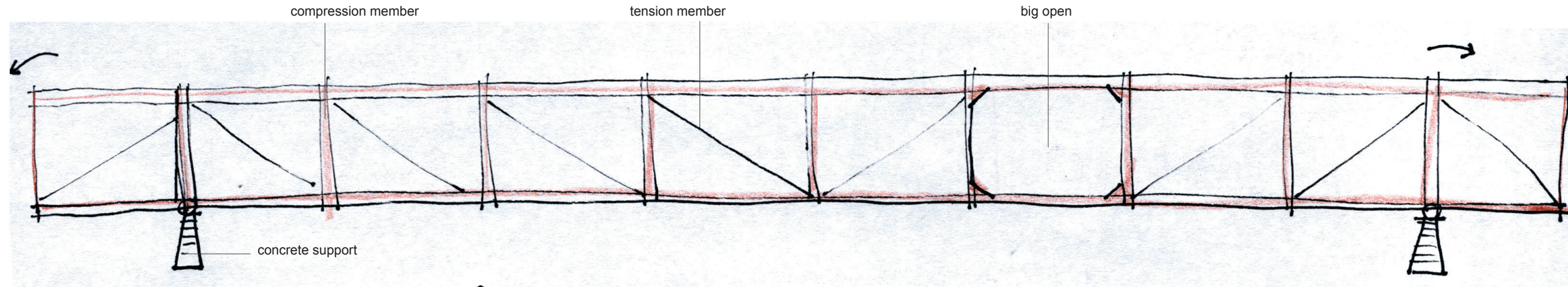

Schematic Diagram of Truss System

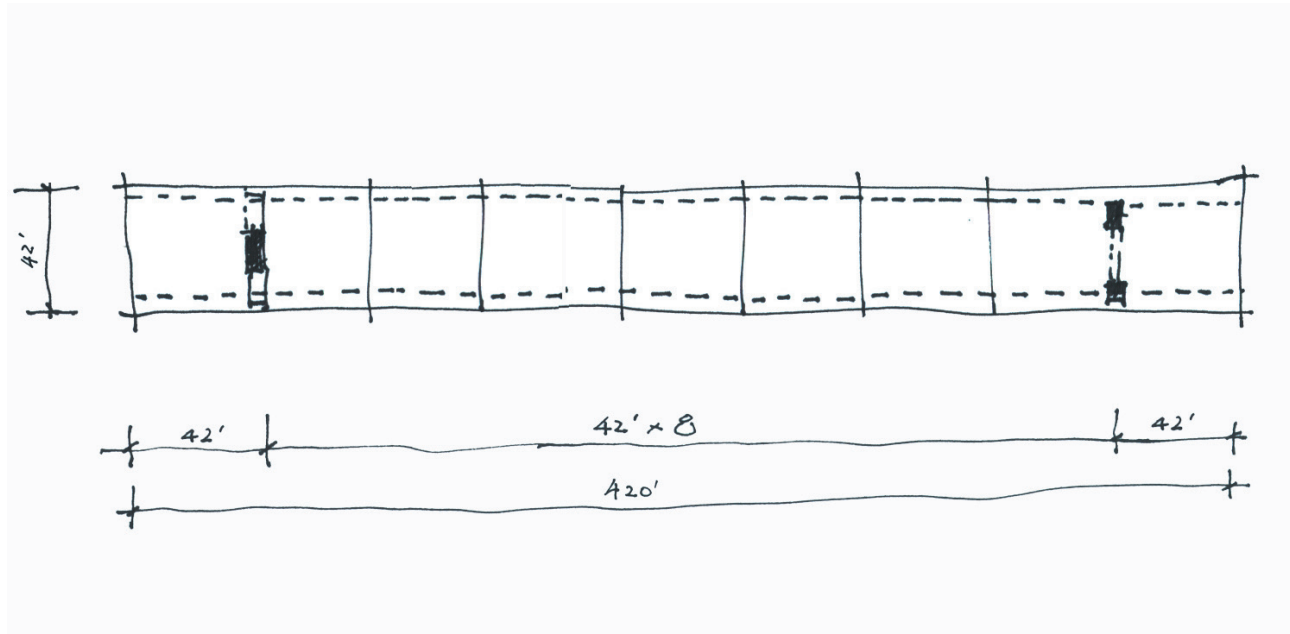

Supports of The Truss

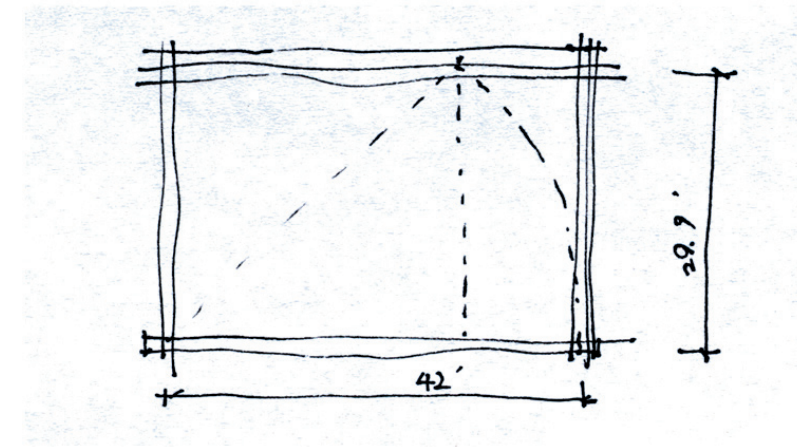

The Proportions of One Panel of The Truss

PRIMARY ARCHITECTURAL CONDITIONS

1. The support is not at the end of truss, helping to lessen deflection at the center, and enhance the sense of structure floating over the landscape.
2. The moment connections enable the truss to have large, unobstructed openings, where the three volumes connect with the bridge.

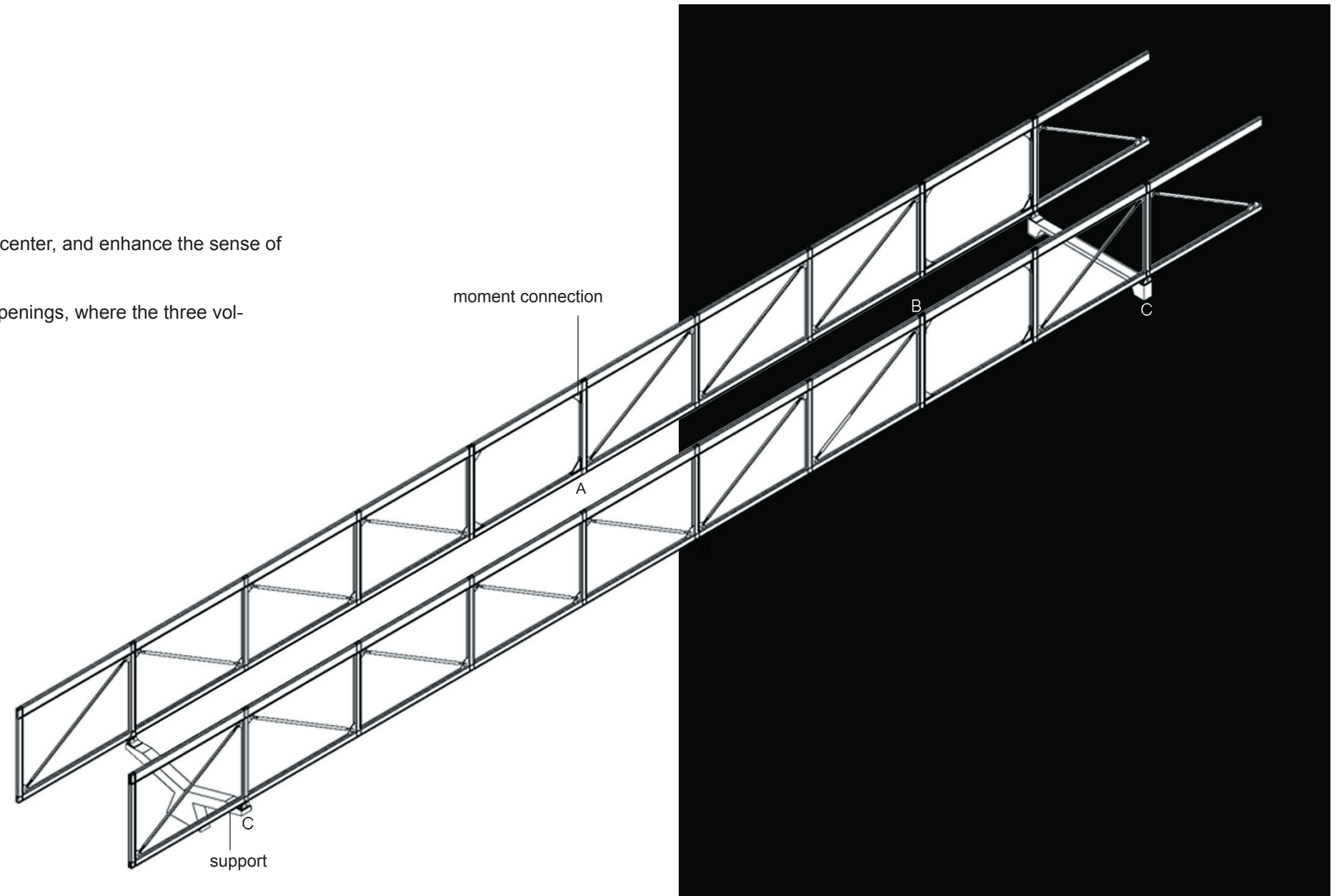

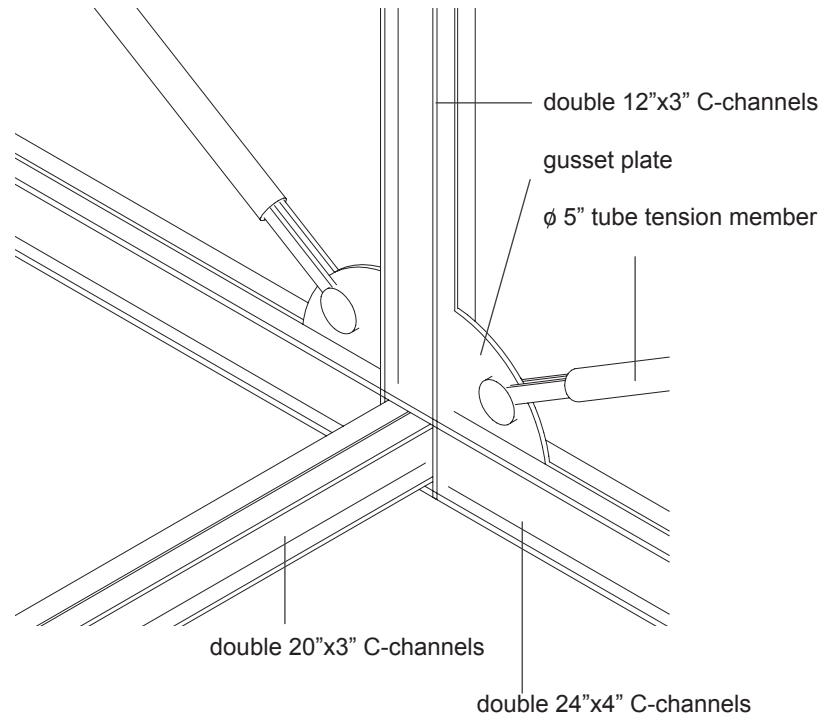

A

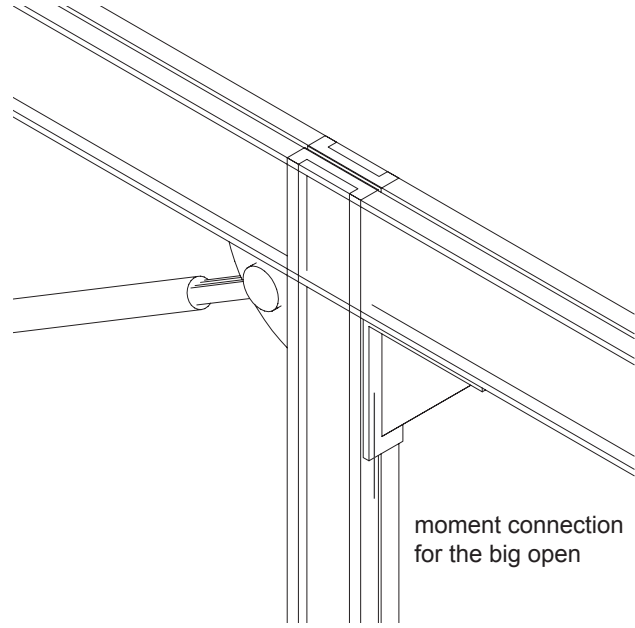

B

Details

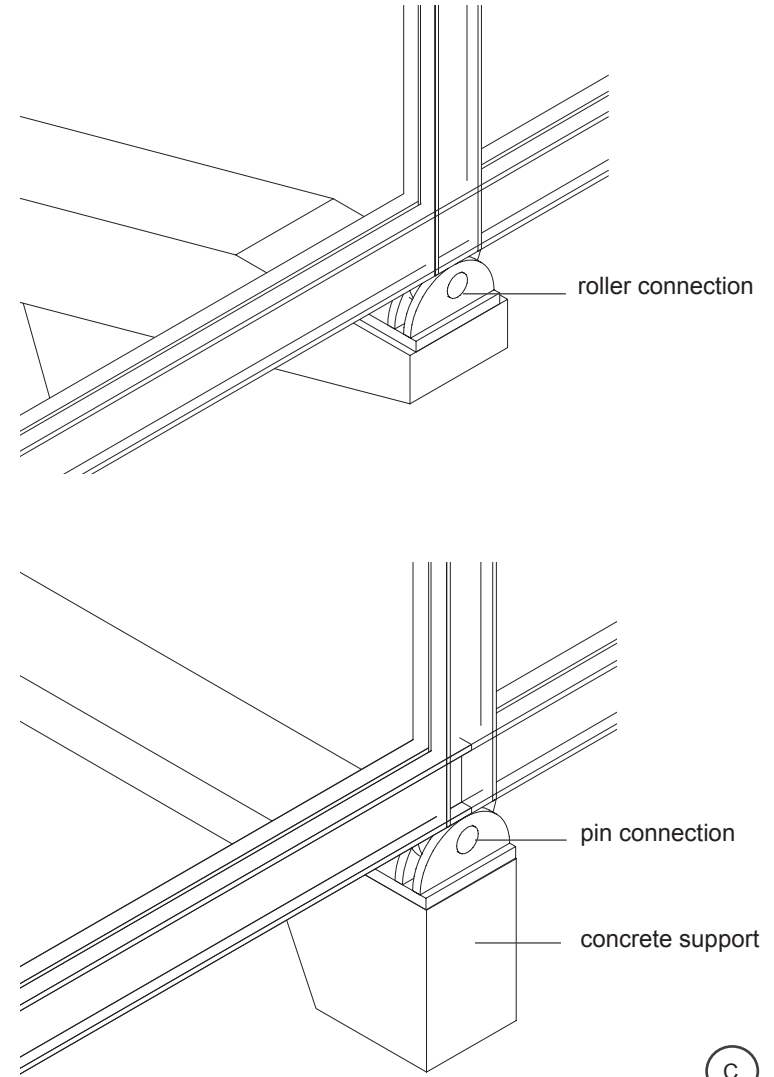

C

3. The three-point support of this bridge animates the structural system, making the strong concrete support an architectural moment as well as functional members.

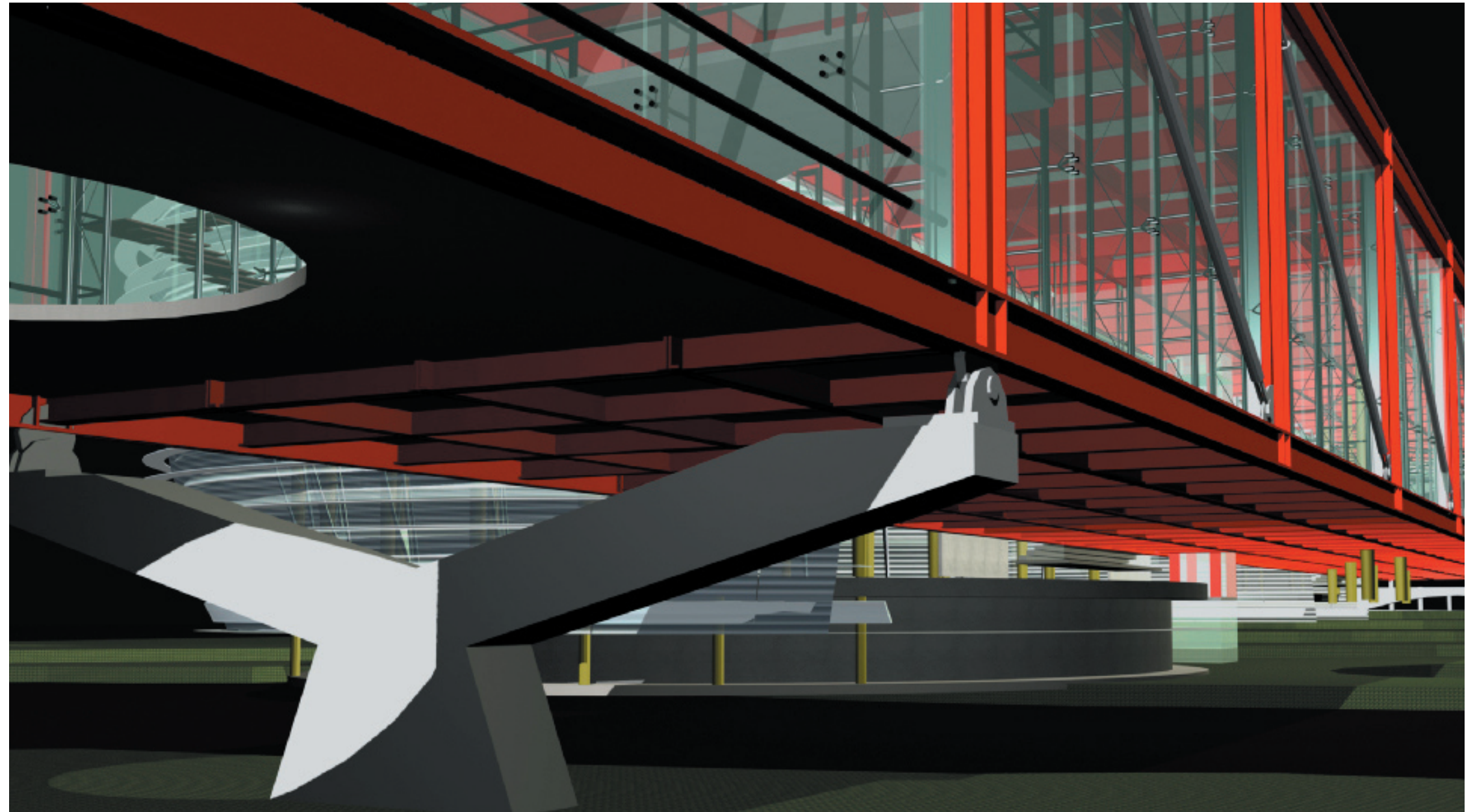

Perspective of Truss Supports

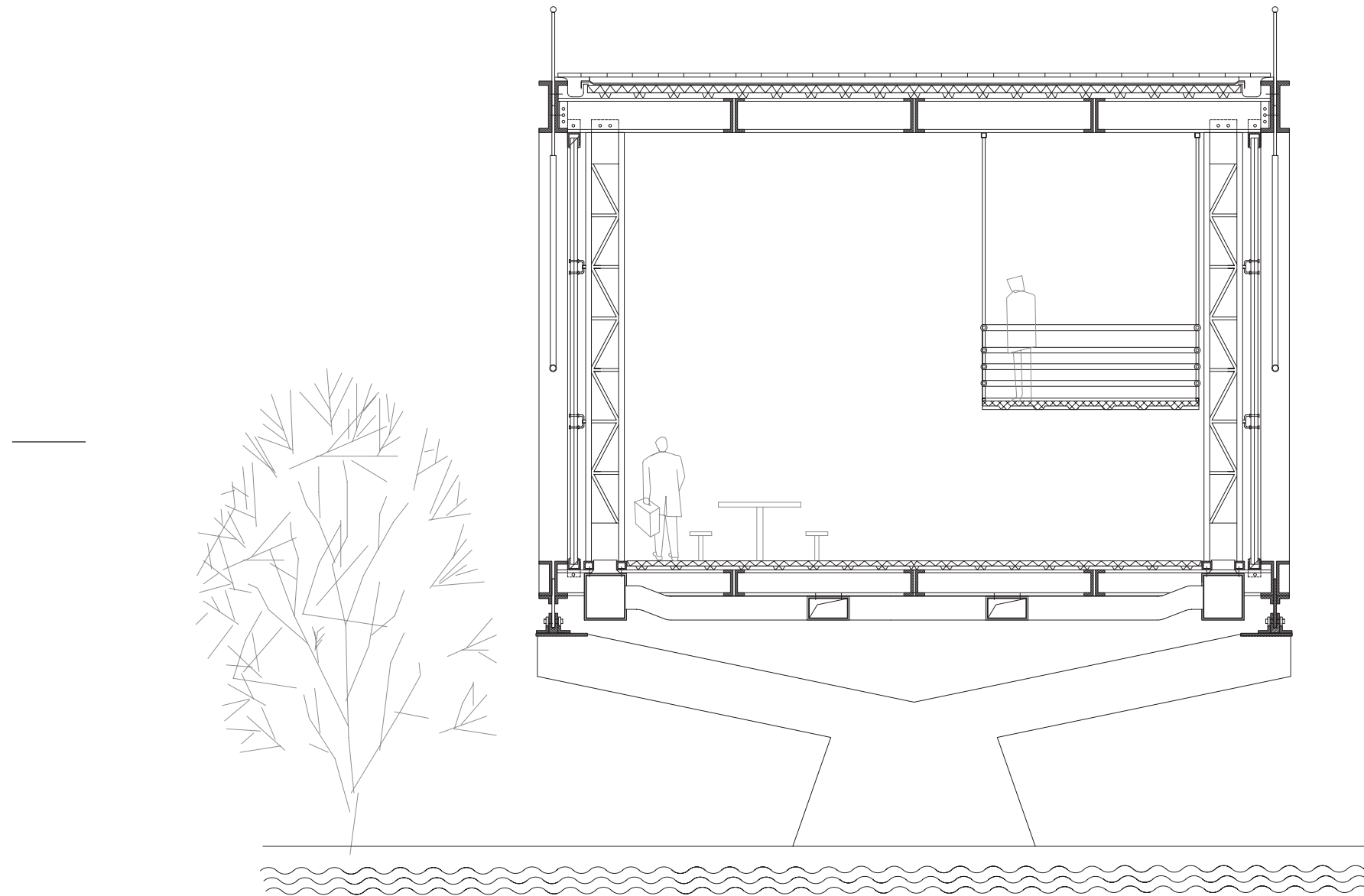

The transparent glass wall enables people to feel the sky, the sun, and the water. Here, the structure and the materials of the bridge work together to create a graceful space.

4, The first panel of the truss forms the entrance. There is a 2' gap between the ramp and the beginning of the truss, which is connected by steel tubes instead of touching the ramp directly. When people step onto the bridge from the ground, they can feel the moment that the space is changing physically and emotionally.

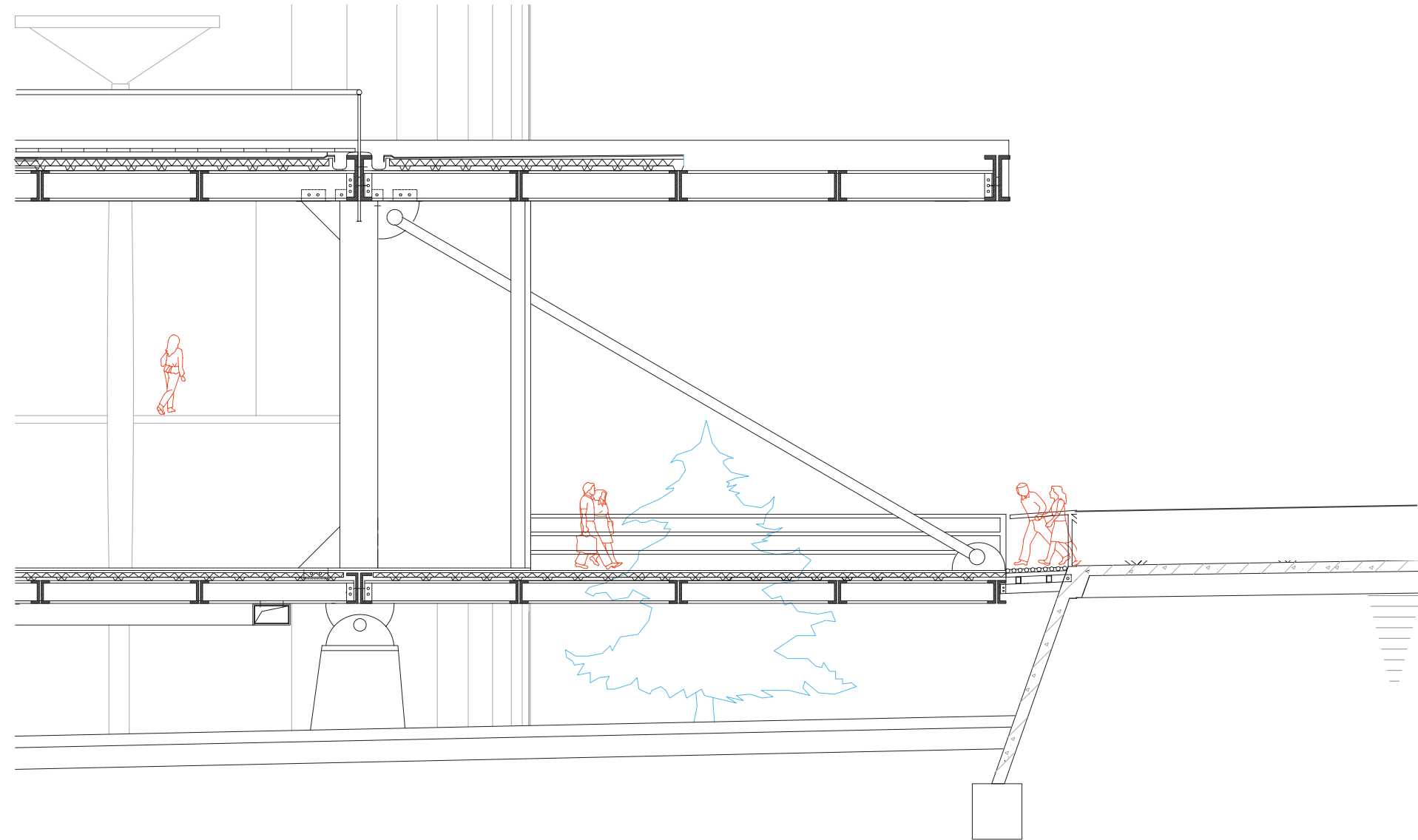

Details of The Entrance

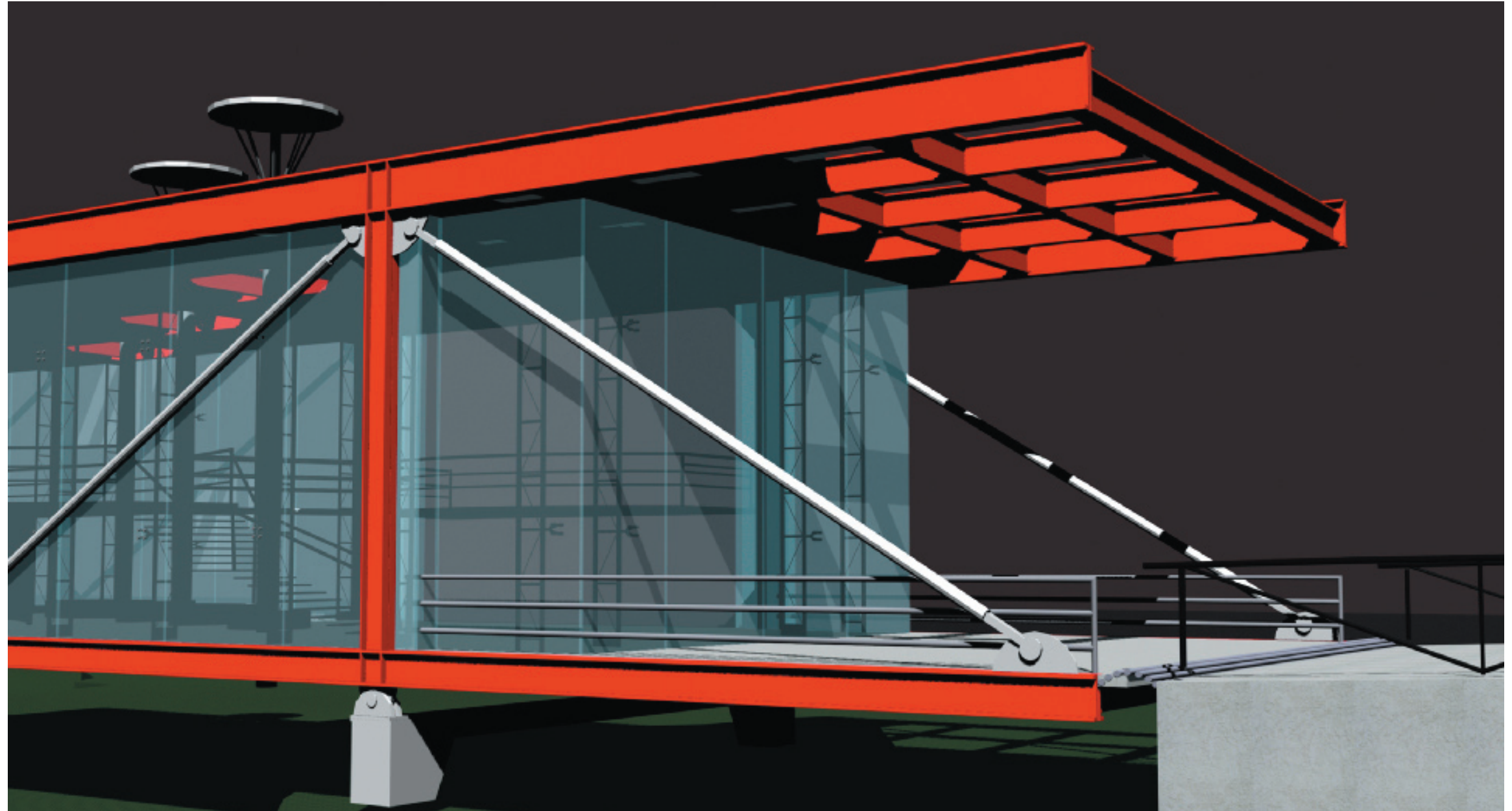

Perspective of The Entrance

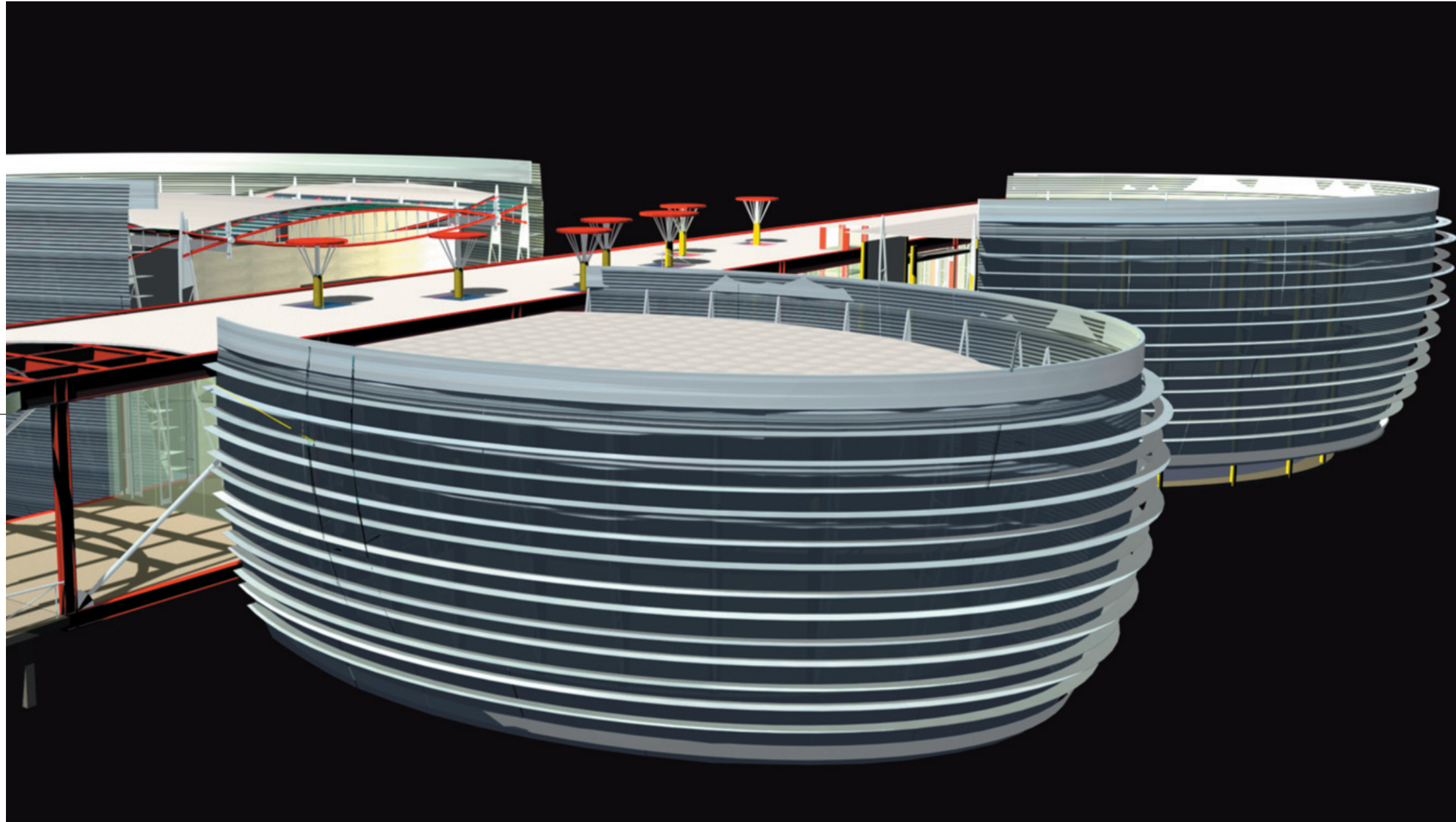

b. The Structure of The Volumes

In contrast to the building's primary space defined by the trusses, the building's secondary functions are contained by three elliptical volumes with an inner structure which carries the roof load and an independent outer structure which supports the curved panel skin.

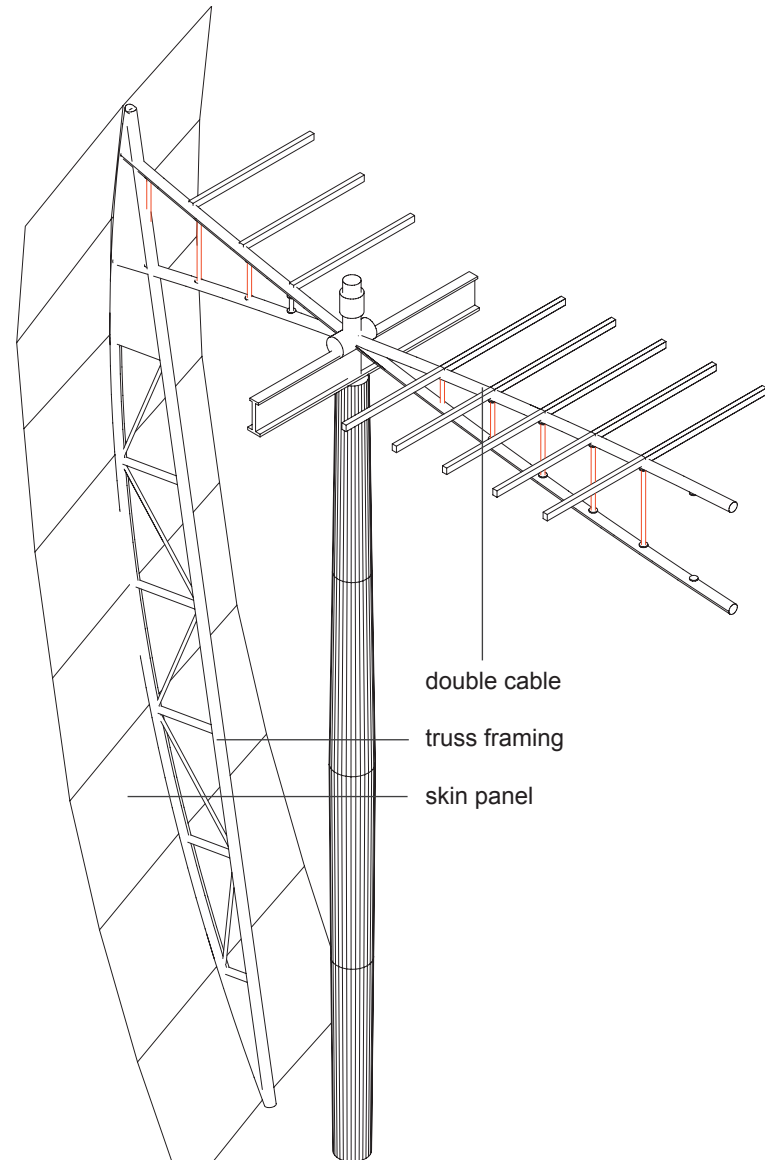

The steel columns and beams, the bones of the volumes, represent strength; the outer structure supports the skin of the building. The horizontal metal sunshading elements enrich the facade as well as preventing direct sunlight. There is no visual confusion between what supports the floor/ roof loads and what keeps out the weather.

The double cable roof structure of the theater creates the void space between roof and ceiling. The air space and the insulated double roof help to acoustically isolate the theater from outside noise.

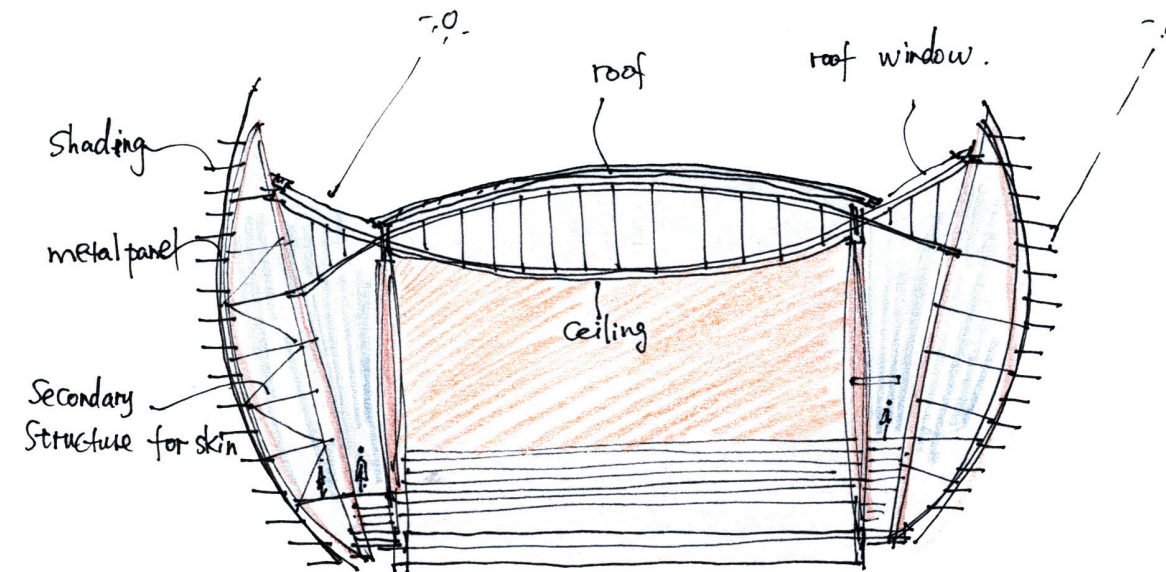

Details of the Double Structure

The skylight and semi-transparent skin illuminate the space between the inner structure and the outer structure. This bright space is available to the public as a part of the theater rooms. The double corridors keep out the noise.

Rendering of Space Between the Double Structure (Corridor of Theater)

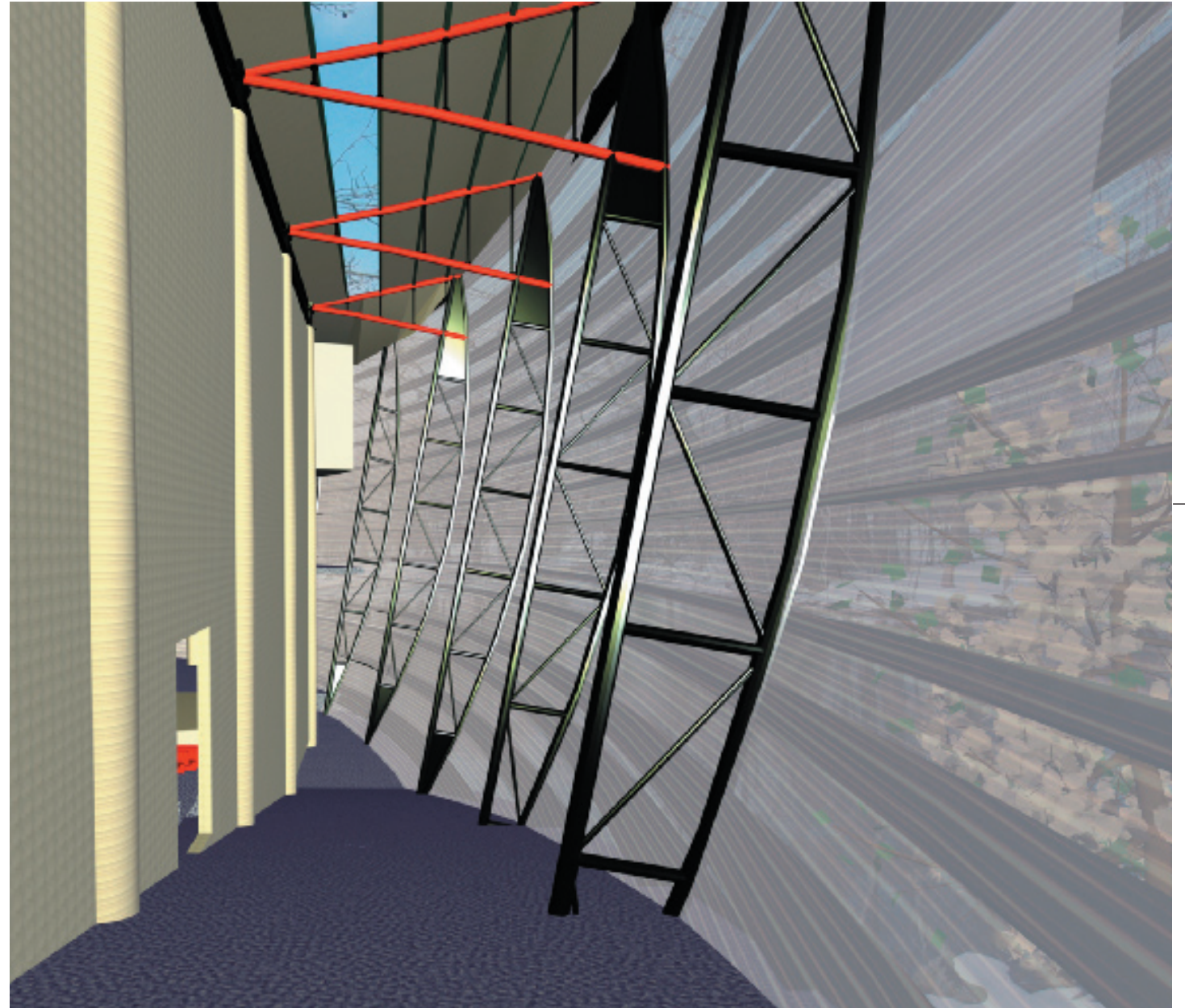

The design of double roof and double wall creates a quiet space for the theater, where people can enjoy the performances in a comfortable environment.

Rendering of Interior (Theater)

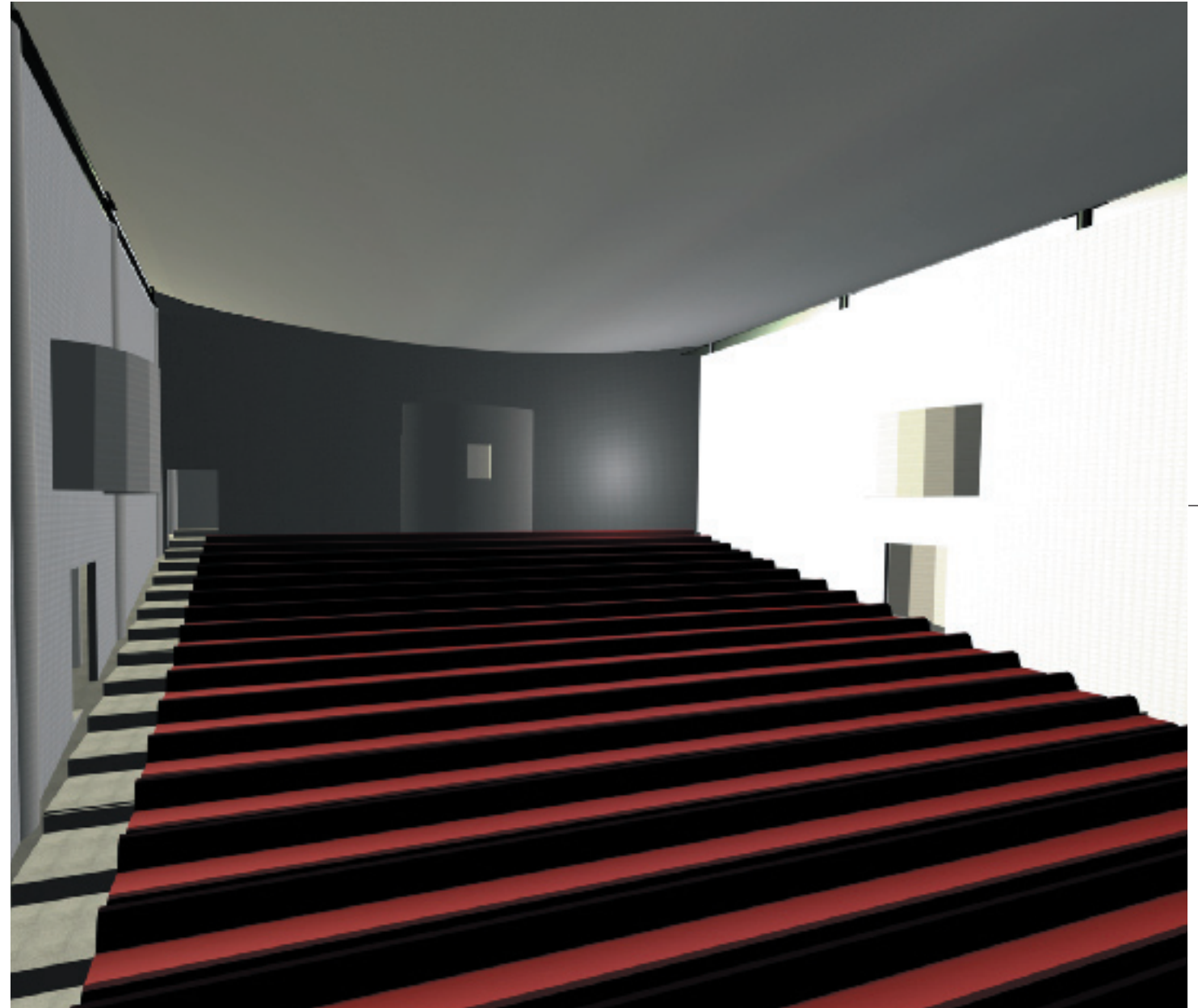

The connection between the two systems (the truss/ bridge structure and the volumes) is a kind of glass box. This makes the connection clear and it creates another moment where people can feel that the space is changing.

Through the glass roof, people can see the truss members from the elliptical space.

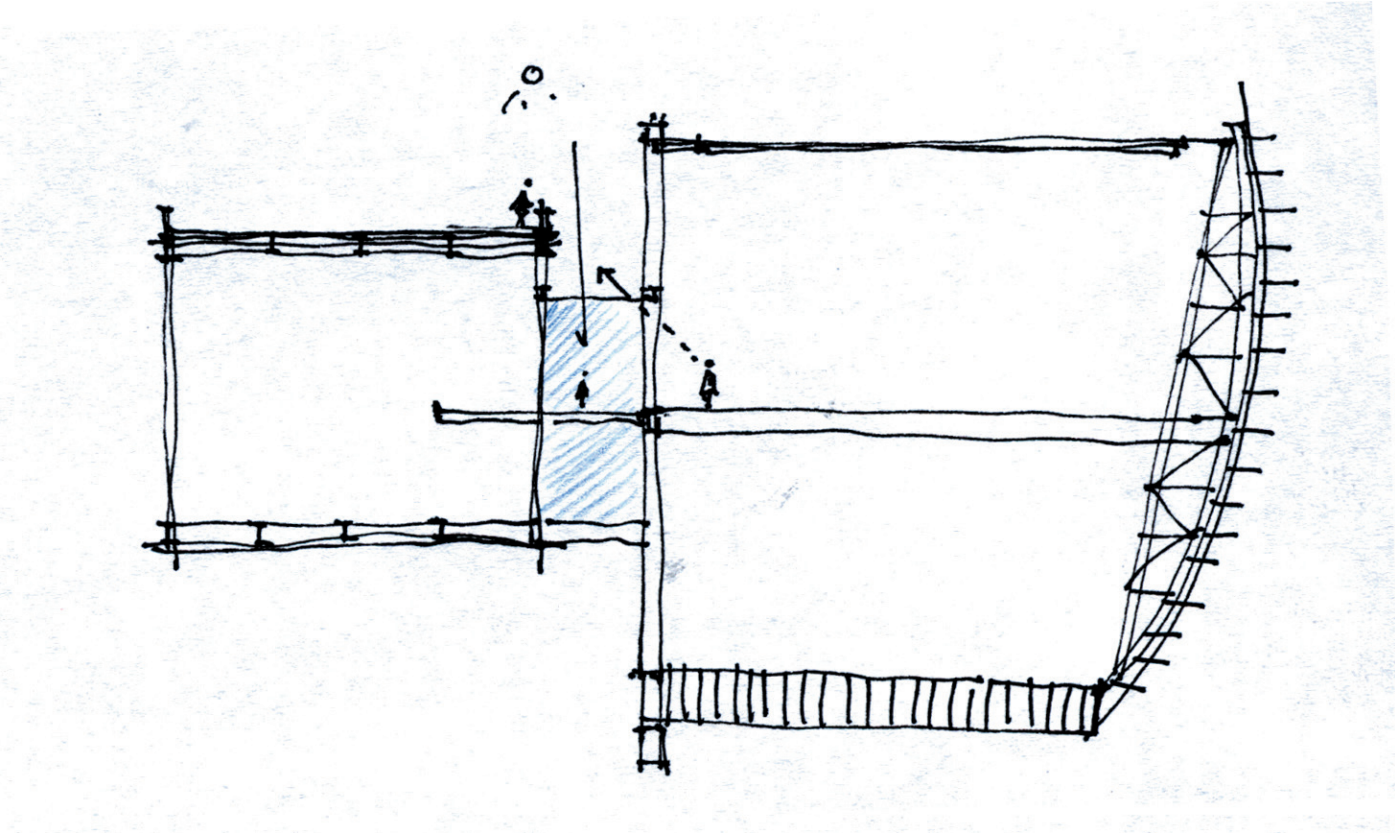

Section Analysis

Connection Between Bridge and Volume (View From Outside)

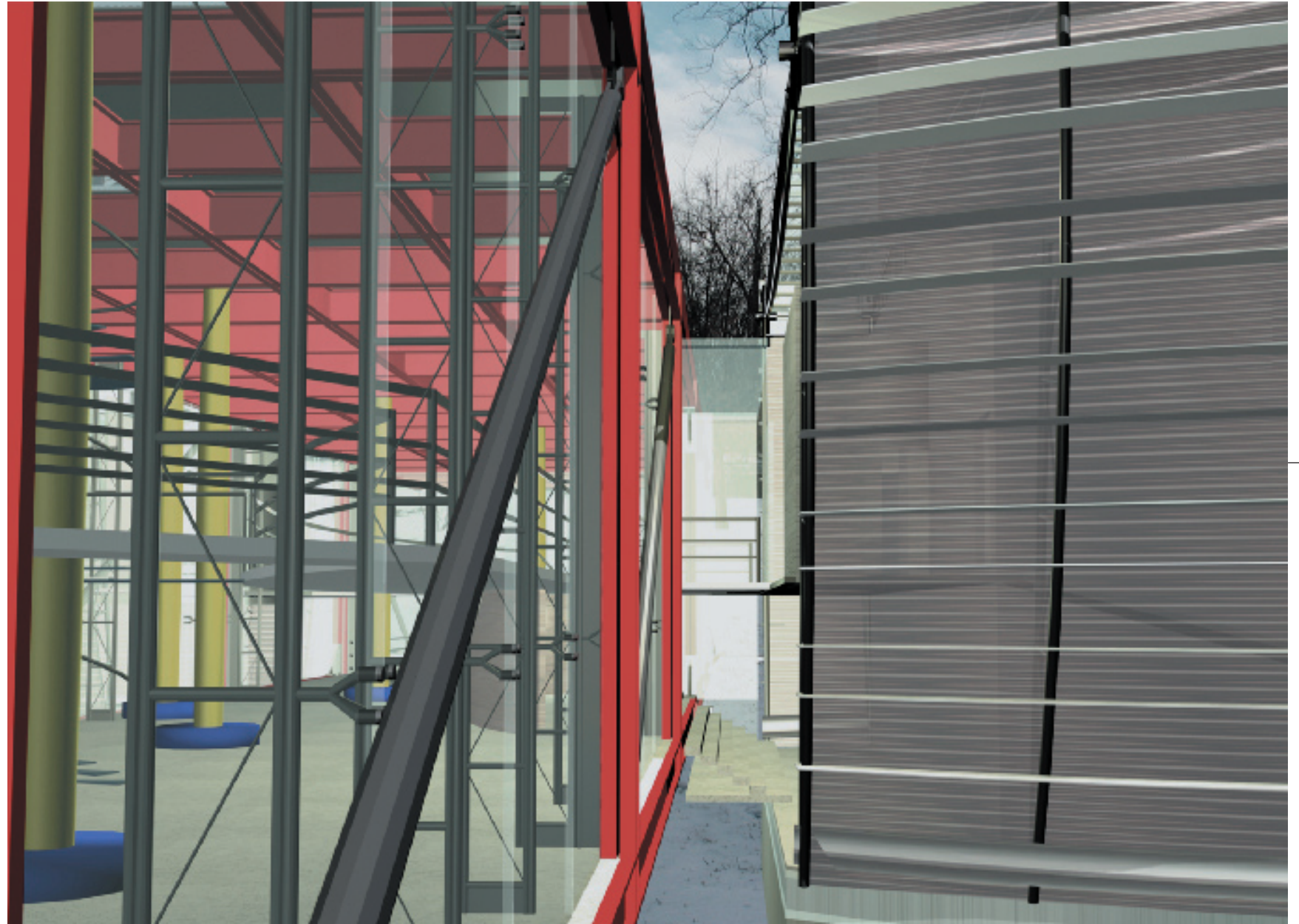

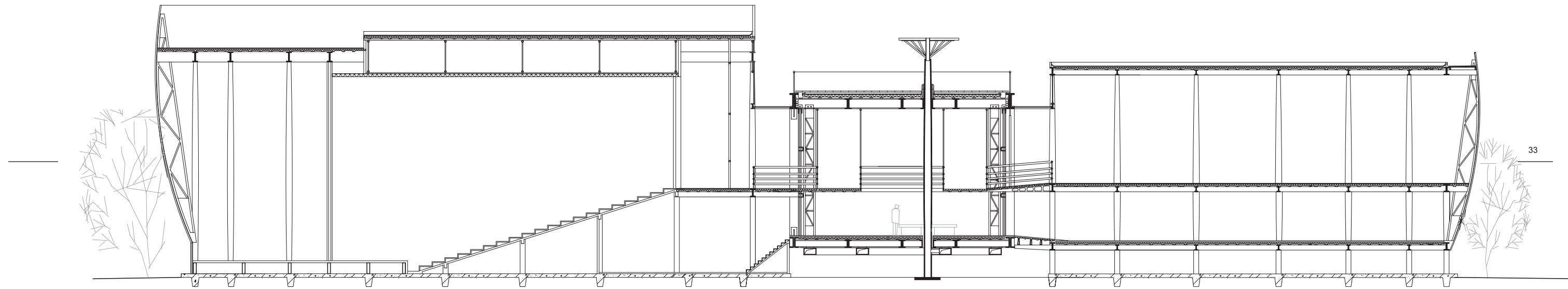

C-C SECTION

0 5 10 15

The section through theater and the bridge shows the relation between the primary truss structure and the structure of volumes containing the building's secondary functions.