

FIBER GLASS PRESTRESSED CONCRETE

by  
Taylor P. <sup>Fitz-Hugh</sup> Turner Jr.

Thesis submitted to the Graduate Faculty of the  
Virginia Polytechnic Institute  
in candidacy for the degree of  
MASTER OF SCIENCE  
in  
Civil Engineering

February, 1963  
Blacksburg, Virginia

## TABLE OF CONTENTS

	Page
I. LIST OF TABLES AND FIGURES. . . . .	4
II. NOMENCLATURE. . . . .	6
III. INTRODUCTION	
A. The Purpose of this Thesis . . . . .	8
B. A Brief History of Glass Reinforcement . . . . .	9
IV. SUMMARY . . . . .	13
V. THE INVESTIGATION	
A. Status of the Science . . . . .	15
1. The first work . . . . .	15
2. Fiber glass reinforcement. . . . .	16
3. Properties of fiber glass. . . . .	25
a. Molecular structure . . . . .	25
b. Production of the fiber . . . . .	29
c. Fiber strength. . . . .	29
4. Properties of glass plastic materials. . . . .	31
5. Conclusions. . . . .	33
B. Investigation of Suitable End Grip . . . . .	36
1. Purpose of investigation . . . . .	36
2. Plan of experimentation . . . . .	36
3. Materials. . . . .	37
a. Supreme Strand Chuck No. 780. . . . .	37
b. Reliable Strandwise No. 5102. . . . .	39
c. Tapered Dowel . . . . .	39
d. Reliable Squeeze Sleeve . . . . .	41
e. Fanngrip. . . . .	41
f. Fiber glass . . . . .	42
4. Procedure and results. . . . .	42
a. Supreme Strand Chuck No. 780. . . . .	43
b. Strandwise No. 5102 . . . . .	44
c. Tapered Dowel . . . . .	46
d. Epoxy and Squeeze Sleeve. . . . .	48
e. Fanngrip. . . . .	49
5. Discussion of Results. . . . .	49
a. Compression and shear . . . . .	50
b. Direct bond . . . . .	52
c. Wedge action. . . . .	53
6. Conclusions. . . . .	54
C. Design and Investigation . . . . .	56
1. Purpose of investigation . . . . .	56
2. Plan of experiment . . . . .	56

## TABLE OF CONTENTS (cont'd.)

	Page
3. Properties of fiber glass . . . . .	57
4. Design of post-tension beam . . . . .	59
5. Fabrication . . . . .	63
6. Test procedure . . . . .	65
7. Critical loads and deflection . . . . .	68
8. Discussion of results . . . . .	72
9. Conclusions . . . . .	74
VI. APPENDICES	
A. Design of Post-tension Beam . . . . .	77
B. Development of Deflection Equations from Revised Moment Area Theorems . . . . .	80
C. Test Data	
Test No. 1. Investigation of Suitable Grip . . . . .	85
Test No. 2.           "           "           "           " . . . . .	86
Test No. 3.           "           "           "           " . . . . .	87
Test No. 4.           "           "           "           " . . . . .	88
Test No. 5. Preliminary Study of Stress Strain Characteristics of Fiber Glass Rod . . . . .	89
Test No. 6. Investigation of Suitable Grip . . . . .	91
Test No. 7.           "           "           "           " . . . . .	92
Test No. 8.           "           "           "           " . . . . .	93
Test No. 9. Investigation of Ultimate Strength and Stress Strain Characteristics. . . . .	94
Test No.10. Calibration of Load Cell . . . . .	96
Test No.12. Investigation of Suitable Grip . . . . .	98
Test No.13.           "           "           "           " . . . . .	99
Test No.14. Investigation of Ultimate Strength and Stress Strain Characteristics. . . . .	100
Test No.15.           "           "           "           " . . . . .	102
Test No.16.           "           "           "           " . . . . .	104
Test No.17. Investigation of Suitable Grip . . . . .	106
Beam Tests . . . . .	107
VII. BIBLIOGRAPHY . . . . .	117
VIII. ACKNOWLEDGMENTS . . . . .	120
IX. VITA . . . . .	121

## I. LIST OF TABLES AND FIGURES

Figure	Page
1. Silica Tetrahedra . . . . .	27
2. Open Structure of Glass . . . . .	28
3. End Gripping Devices. . . . .	38
4. Tapered Dowel Grip . . . . .	40
5. Revised Supreme Strand Chuck . . . . .	45
6. Tapered Dowel Grip and Clamp . . . . .	47
7. a. Post Yield Strain Gage on Specimen . . . . .	53
b. Set up for Tensile Test . . . . .	58
8. Typical Stress Strain Curve . . . . .	61
9. Cross-section of Beam . . . . .	62
10. a. Test Beam . . . . .	64
b. Beam Mould . . . . .	64
11. a. Tensioning Device. . . . .	66
b. Method of Tensioning . . . . .	66
12. Tension Indicator . . . . .	67
13. a. Equipment set up for Post-tensioning . . . . .	69
b. Equipment set up for Beam Test . . . . .	69
14. Load Deflection Curves . . . . .	75
15. Beam Properties and Loading . . . . .	78
16. Curvature Geometry and Force Diagram . . . . .	82
17. Unit Rotation and Conjugate Beam Diagram. . . . .	84
18. Stress Strain Curve - Test No. 9 . . . . .	95
19. Calibration Curve for Load Cell . . . . .	97
20. Stress Strain Curve - Test No. 14 . . . . .	101

Figure	Page
21. Stress Strain Curve - Test No. 15 . . . . .	103
22. Stress Strain Curve - Test No. 16 . . . . .	105
23. Details of Tensioning Device . . . . .	108
24. Tension Indicator . . . . .	109

#### Table

I. End Grip Strength . . . . .	51
II. Ultimate Stress and Elastic Modulus for 1/4 inch Diameter Fiber Glass Rod. . . . .	60
III. Compressive and Flexural Strength of Concrete Test Specimens . . . . .	111
IV. Test Data Beam No. 1. . . . .	112
V. Test Data Beam No. 2. . . . .	114
VI. Test Data Beam No. 3. . . . .	116

## II. NOMENCLATURE

I	- Moment of inertia taken about centroid.
L	- Clear span of beam.
P	- Total load.
T	- Tension in prestressing element.
$A_c$	- Area of concrete.
$A_g$	- Area of fiber glass.
$E_c$	- Modulus of elasticity of concrete.
$E_g$	- Modulus of elasticity of fiber glass.
$M_L$	- Moment due to live load.
$M_D$	- Moment due to dead load.
$P_c$	- Cracking load.
d	- Effective depth of beam.
e	- Eccentricity.
p	- Percent of fiber glass to concrete.
w	- Weight of beam per foot.
x	- Distance measured from point of support.
$C_b$ & $C_t$	- Distance from bottom and top fiber to centroidal axis.
$f_b$	- Stress in bottom fiber of concrete.
$f_c$	- Stress in concrete.
$f_g$	- Stress in fiber glass.
$f_t$	- Stress in top fiber of concrete.
$f_{bi}$ & $f_{bf}$	- Initial and final stress in bottom fiber of concrete.

- $f_{ti}$  &  $f_{if}$  - Initial and final stress in top fiber of concrete.
- $f_c$  - Compressive strength of concrete.
- $f_t$  - Tensile strength of concrete.
- $\Delta_c$  - Deflection at first crack.
- $\Delta_f$  - Total change in stress between top and bottom flange of concrete from initial to final stage.
- $\Delta_u$  - Ultimate deflection.
- $\phi_c$  - Unit rotation at first crack.
- $\phi_u$  - Ultimate unit rotation.
- $\epsilon_c$  - Strain in concrete.
- $\epsilon_g$  - Strain in fiber glass.

### III. INTRODUCTION

#### The Purpose of the Thesis

The purpose of this thesis is threefold. First, to present a review of the literature available to acquaint the reader with the development of the science up to the present date and to give an understanding of the problems encountered in developing glass as reinforcement for concrete. Second, to report the findings of an investigation for a suitable grip for holding fiber glass rods\* during prestressing. And third, to discuss the results of several concrete beams designed as post tensioned members and tested in flexure to study deflection.

Even though there has been a great deal of study toward developing a working knowledge of the properties of fiber glass reinforced concrete, much remains to be accomplished before significant data is available from which sound engineering practice will dictate the application of such a system.

Two areas which require investigation are end gripping devices and developing sound design criterion to check members for working and ultimate loads and deflections.

The material presented in this paper will provide the reader with a background of previous work relating to fiber glass prestressed concrete and additional data pertaining to end grips and design criterion.

---

\* The term fiber glass as used in this thesis refers to glass fibers bonded together with either a polyester plastic or epoxy materials.

### A Brief History of Glass Reinforcement

It is known that glass has been considered for use as a structural material for over thirty years. (1)\* However, with the advent of the second World War the need of a substitute for steel was realized.

In 1940 a report (2) on a series of tests conducted in England showed that glass strips could successfully be used to replace steel as reinforcement for concrete. Not only were the tests encouraging for the possibility of finding a substitute for steel but there were indications that the physical properties of glass might allow the material to replace steel in many instances. The tests made in England were on rectangular beams in which strips of glass had been placed vertically in the bottom half of the beam thereby replacing the concrete which normally has little structural value other than to hold the steel reinforcing rods. It was concluded that plain sheet glass may provide suitable reinforcement for concrete under static loading but should not be used where impact loads are encountered.

Between the years 1940 and 1950 most of the work relating to glass reinforced concrete dealt with solid glass rods or strips. Even though this work was successful it was realized that the low modulus of elasticity of the glass resulted in an inefficient member for practical structural design.

---

\* Numbers in parentheses refer to the bibliography.

The first major development in the science of glass reinforcement came around 1951 when Professor Ivan A. Rubinsky, then working at Princeton University, published an article<sup>(4)</sup> in which he stated that the great tensile strength of glass together with its relatively low modulus of elasticity could be utilized in prestressing concrete.

Not only did Rubinsky foresee the possibilities for incorporating the physical properties of glass fiber into the production of prestressed concrete, but he understood the economics involved in areas of the world where steel was either out of the question due to high cost or where there was lack of the raw materials from which it is made.

The materials from which glass are made are found in almost all parts of the world in large quantities. Also the process for making fiber glass of suitable quality was readily available. These two facts and the fact that fiber glass has a strength to weight ratio equal to the best steel alloys available would allow fiber glass to compete favorably with ordinary reinforcing steel.

After preliminary investigations in which Professor Rubinsky experimented with fiber glass in the form of glass rope, tape, and polyester-bonded fiber glass rods, it was concluded<sup>(5)</sup> that, due to the difficulty of gripping the fiber glass, tapes would be desirable for post tensioning. The tape would eliminate the need for an expensive grip, since it would tend to

hold itself as it was wrapped around the beam. However, before serious consideration could be given to the use of fiber glass for construction it would be necessary to develop a means to protect the fiber glass from the effects of humidity and alkali reaction. Also it is necessary to find a method of increasing bond and anchorage between the fiber glass and the concrete.

From this beginning the work has been carried on in the United States under the combined efforts of the U. S. Navy Bureau of Yards and Docks; the Army Engineering Laboratories; and many of the leading universities and glass companies.

However, interest in the field of fiber glass prestressed concrete is not confined to the United States. There has been considerable research overseas especially in Germany and Russia.

It is interesting to note that all of the work has not been confined to laboratory investigation. Several instances of practical application are on record. The first use of fiber glass prestressed concrete is thought to be in window sills for a building at Princeton University, and recently there has been a report that: "Thin filaments of glass fibre coated and bound together with polyester resin are already used for the reinforcement of concrete pipes to carry water under pressure."(6)

Although fiber glass has been used to prestress concrete this should by no means infer that it is ready for acceptance as a practical construction material. There is much to be learned of its physical properties under varying conditions over a long period of time.

Two schools of thought exist today on the proper approach toward gathering data for furthering the science of prestressing concrete with glass fibers.

One school is of the opinion that before any constructive work can be accomplished much research is necessary on the individual components comprising the member. These are the glass fibers, the synthetic resin bonding the fibers together and the concrete in which the fiber glass is cast.

The other school is of the opinion that more knowledge would be derived from research directed to studying actual members prestressed with fiber glass.

Both of these approaches have merit but the latter may produce the answers to many questions long before detailed tests on the separate materials. In fact it is entirely possible that glass will come into prominent use as a structural material long before extensive knowledge has been acquired of the physical behavior of the individual materials from which a finished structural member is composed.

## IV. SUMMARY

Even though glass has been considered as a substitute for steel only a short time there are many favorable indications that glass in the form of fibers will eventually prove satisfactory as tensile elements in prestressed concrete.

This thesis presents a review of the available literature, the results of an investigation of end gripping devices, and the test results of beams designed as post tensioned concrete members having fiber glass tension elements.

Previous work has shown the physical properties of fiber glass to compare favorably with those of prestressing steel. Fiber glass has an elastic modulus from three to four times less than steel while the tensile strength and bonding property with concrete are reported to be in the same order of magnitude as steel.

The development of a practical end grip is one of the greatest single factors preventing the development of fiber glass prestressed concrete. Although many previous findings were verified during the investigation, no solution has been found to the problem of holding the fiber glass without premature failure of the rod. A satisfactory grip must be capable of carrying the ultimate tensile strength of the fiber glass.

Although there were only three beams designed and tested using fiber glass as the tension element, the data collected

show that the present design concepts should be adequate for fiber glass prestressed concrete. However, a method of calculating ultimate loads must be found before adequate safety factors can be chosen.

## V. THE INVESTIGATION

### Status of the Science

Although it has been reported that the use of glass as a material for reinforcing concrete began around 1930, much of the work reported on in this thesis has been done since 1950.

#### The first work

The only references to papers prior to 1940 were found in a bibliography published by the U.S. Army Corps of Engineers.<sup>(1)</sup> One of these papers was published by Graemer<sup>(7)</sup> in the early thirties dealing with glass reinforcement for concrete. The other was a paper by Goldstein and Bolocan<sup>(8)</sup> titled, "Perfection of the production of reinforced glass concrete with optimum water content."

In 1940, reports<sup>(2,3)</sup> were published of tests carried out in England which indicated glass had been successfully substituted in place of steel as reinforcement for concrete. The tests were carried out by Mr. A. W. Soden, Mr. J. A. Lincoln and Mr. W. S. Marshall. Using glass strips embedded in the bottom or tensile region of the beams, bending and impact tests were made. The results obtained in bending compared favorably with ordinary steel reinforced concrete. However, it was noted that there were several disadvantages, these being the sudden failure associated with brittle materials

and the low resistance to impact loads. Subsequent testing showed that the bond developed between glass and concrete was very good. It was concluded that glass should not be used as reinforcement when impact loads are likely to occur. The tests performed showed that for static loading glass would make a suitable reinforcement for concrete.

### Fiber glass reinforcement

The first thought of using glass fiber as reinforcement for concrete appears to have come from Ivan A. Rubinsky\*, who in 1951 was working at Princeton University, Princeton, New Jersey.

An article<sup>(4)</sup> published in March 1951, points out that Rubinsky realized the economic as well as the physical advantages of glass fiber for prestressing concrete.

According to Rubinsky there are many countries which cannot benefit from the use of prestressed concrete due to the lack of high strength steel. However, the raw materials for making glass can be found almost anywhere in the world in great quantities. This may make the substitution of glass for steel advantageous. Other advantages of glass are its high tensile strength and the apparent lack of plasticity. Due to the high strength to weight ratio of glass, the weight of

---

\* Mr. Rubinsky was an associate professor of engineering and physics at the American University, Beirut, Lebanon. He holds a Lebanon patent(+) on the use of fiber glass prestressed concrete.

+ Ibid. Ref. (1) p. 42.

glass in a prestressed concrete beam would be one or two percent of the weight of steel in an equivalent reinforced concrete beam.

Other advantages of glass fiber are pointed out by Rubinsky as being the high resistance to acids and alkalis of some special glasses and the ability to withstand high temperatures. Therefore concrete with glass as a prestressing element would be more resistant to heat than an equivalent member using steel and immune to corrosion by salt water and many chemicals.

The article then points out that some of the physical properties of glass introduce problems which must be solved before glass can be used in prestressed concrete. One of these is the change in strength between wet and dry fibers. The low strength is attributed to the effect of moisture upon the silica gel exposed through surface cracks in the glass. However, this would be reduced or eliminated in fiber glass since the glass fibers are protected from moisture. Another problem is the varying strength as the diameter changes.

In 1954 Rubinsky published an account<sup>(5)</sup> of his work while at Princeton University. Here he emphasizes the high strength of glass fibers by referring to the work of Anderegg, Jurkov, Aslanova and others which indicate values as high as  $2.0 \times 10^6$  to  $4.0 \times 10^6$  pounds per square inch. However, it is pointed out that these are only laboratory tested samples and that strengths of commercial fibers have been recorded that average 270,000 pounds per square inch.

Rubinsky further points out that static fatigue is an important property of fiber glass. It was found that the duration of load had a relation to the ultimate strength. However, he was unable to determine whether the effect of static fatigue was due to the properties of the glass fiber itself or to creep within the bonding material.

Among the major problems, found by Rubinsky, retarding the development of fiber glass reinforcement is that of effecting the transmission of tension from the reinforcement to the concrete. Preliminary studies have shown that the transmission of tension may be accomplished in the following ways:

1. Direct bond to concrete
2. Jaw grip
3. Winding cord around web of beam
4. Bonding glass to grip with adhesive

In the same year that Rubinsky's work was reported, Mr. Ray B. Crepps<sup>(9)</sup> presented a summary of information on the application of fiber glass in the design of prestressed concrete structures.

This paper, it was stated, was to point out several problems of concern in the application of fiber glass to prestressed concrete.

Mr. Crepps points out that due to the low modulus of glass it should be desirable as a material for prestressing

concrete. The low modulus would largely reduce the loss of prestress experienced in conventional design due to shrinkage and flow in concrete.

Among the desirable properties of fiber glass, reported by Crepps, were high tensile strength and the reliability of reproducing high strength strands in the production of commercial fibers. Also the stress strain curve is, for all practical purposes, a straight line. The material, unlike steel, experiences no yield point or yield strength.

The report further states that reinforced plastic rods using parallel glass fibers give tensile strengths per unit area which are only slightly lower than the combined strength of the individual fibers. Although strengths of 210,000 pounds per square inch have been obtained, most rod stock has a strength around 130,000 pounds per square inch. The modulus of elasticity may vary between  $4 \times 10^6$  and  $7 \times 10^6$  pounds per square inch.

Although fiber glass has several desirable properties Crepps outlines several problems which need further investigation.

One of these problems is finding a suitable grip for holding the fiber glass during the stressing operation. The grip should hold the fiber glass so that all strands are equally stressed to prevent failure before ultimate strength is

attained. Also, due to the low modulus of fiber glass, any prestressing system should be capable of three to five times the movement encountered with steel.

Another problem discussed by Crepps is the question of durability of glass fibers embedded in portland cement concrete. This concern is due to the fact that hydration of portland cement occurs at a pH of about 12 and a pH of eight or nine is undesirable for some glasses. However, there are many compositions of glass, some superior to others in the presence of alkalis. In the case where glass fibers are embedded inside a plastic, as in fiber glass, this problem is greatly reduced since several plastics are resistant to alkalis to at least a pH of twelve.

In 1952 Kenneth W. Keane<sup>(10)</sup> concluded a study of fiber glass as a prestressing element in concrete. This study was a continuation of the work begun by Rubinsky at Princeton in connection with a Navy contract.

Due to the difficulty, which Rubinsky encountered, of finding an end grip for holding the fiber glass, Keane devoted most of the study to an investigation of different types of grips. The grips used were of two basic types: mechanical grips which relied on friction developed by compressive force to transfer tension in the fiber glass to the grip, and grips using cold setting resins to either transfer the tension by direct bond or by wedge action.

Keane found that of the mechanical grips, the bolted plate grip gave a maximum stress in the rod of 123,000 pounds per square inch. However, the compressive force required to properly hold the rods caused partial failure within the grip before the fiber glass was subjected to tension. This led to the conclusion that a grip which transferred the load by direct bond may prove satisfactory.

The grips tested using cold setting resin to bond the fiber glass to the grip gave most promising results. The highest ultimate quick strength reported was 217,000 pounds per square inch.

Keane also investigated several of the physical properties of fiber glass and concluded that creep did occur. This is contrary to earlier reports by Rubinsky. Another property, that of static fatigue, is explained as the result of creep within the bonding matrix. The creep relieves stress within the matrix and redistributes it to the glass fibers. This redistribution results in the glass fibers on the outside being overstressed causing failure.

Much of the work done at Princeton by Keane and others had been supervised by Norman J. Sollenberger.<sup>(11)</sup> In 1953, Sollenberger reported on the development of an end grip believed to be satisfactory for determining the properties of 1/4 inch diameter fiber glass rods. The grip was patterned after a Standard Rocbling Strand Socket.

Sollenberger further reported the modulus of rupture of 1/4 inch diameter rod, having 54 per cent glass by volume, to be 150,000 to 200,000 pounds per square inch and the tensile strength to be 100,000 to 120,000 pounds per square inch. The allowable working stress was reported as one-half the ultimate quick tensile strength.

Following Keane's work at Princeton, John Maximillian Weis, working under the supervision of Sollenberger, reported on the effects of repetitive loading on fiber glass rods in prestressed concrete construction. (12)

When studying the effect of fatigue, Weis utilized concrete beams designed so that the tension in the fiber glass rods could be easily computed. A repetitional loading machine was used to load the beams. The cycle of loading remained constant and the load was varied between 300 and 780 pounds.

The results of tests made by Weis indicate that the endurance limit for fiber glass rods is approximately 52 per cent of the ultimate stress. The tests also showed that excessive flexure in beams should be investigated.

Work continued at Princeton and in 1960, Frank J. Maguire, working on a master's degree, wrote a report (13) that summarized the work done at that university. In this thesis Maguire reviews each phase of the work done at Princeton giving details of methods used for testing the fiber glass and the prestressed concrete members.

Among the findings reported by Maguire are that epoxy laminated fiber glass rods are superior to others in short time tests. The epoxy laminated rod has shown short time strengths as high as 224,000 pounds per square inch. Also the phenomenon of static fatigue was found to exist in glass fibers when exposed to moisture, but creep, at stress levels low enough to avoid static fatigue, was not thought to be present.

Maguire also reported on developments of holding devices and coatings to increase bond.

The holding device found to be best for making tensile tests on fiber glass rods was a concrete end block approximately two and one-half feet long, one foot wide, and three inches deep. A tensile specimen made with this end grip weighs about 250 pounds and is therefore good only in the laboratory. Another grip using bakelite resin to form a wedge inside a pipe gave ultimate quick strengths averaging 184,000 pounds per square inch.

To improve the bonding property of concrete to fiber glass Maguire reports that coating the rods with an abrasive material works satisfactorily. However, the coating used to bond the abrasive to the rod is sometimes adversely affected by elongation of the fiber glass rod under working stresses.

While the work at Princeton was in progress a paper<sup>(14)</sup> was published in Russia by K. L. Biryukovich dealing with glass fiber reinforcement for concrete. The author investigated the use of glass fiber in the form of woven rope and plastic coated bundles for reinforcing concrete.

It was reported that to protect the glass from alkali reaction, strands with diameter in excess of  $2 \times 10^{-6}$  inches are required. Smaller fibers are dissolved unless coated with synthetic resin films.

Tests made by Biryukovich on fiber glass indicate a maximum bond strength of around 410 pounds per square inch. This was obtained by applying prestress to the fiber glass before placing the concrete.

The most difficult problem found by Biryukovich was determining the proper amount of prestress due to the effect of static fatigue. It is noted that previous findings indicate that static fatigue occurs at loads approximately 63 per cent of the ultimate quick strength. But, the tests reported were insufficient to solve the question of permissible stress.

The only other work found relating to fiber glass prestressed concrete was reported in the Magazine of Concrete Research. This article,<sup>(15)</sup> written by Dr. Ing S. Kajfasz, presents test results of twelve beams designed as prestressed members using glass fiber cord as a tension element.

Dr. Kajfasz used an inverted tee cross-section, and the beams were cast in two sections. Tensioning was accomplished by wedging the two sections apart.

The results reported by Dr. Kajfasz show several interesting facts. First, the expected prestress force never developed in the glass fiber tendon. Secondly, it was observed that as cracks developed in the beam the moment varied and in some cases the permanent deflection increased after each crack.

In conclusion, Dr. Kajfasz states that the low initial stress which could be placed on the glass fiber cords caused unfavorable results when compared with steel prestressed beams. In his opinion, before glass fibers can be utilized satisfactorily not only must the initial stress be increased but a better bond must be developed between the concrete and glass.

#### Properties of fiber glass

As investigations continued to indicate that fiber glass might be feasible as reinforcement in prestressed concrete, questions arose as to the physical characteristics of glass fibers and how these properties might affect its use as reinforcement in concrete.

#### -- molecular structure --

Many of the physical and chemical properties of glass and glass fiber are best understood by studying the molecular structure.

According to Cameron<sup>(16)</sup> glass is composed mainly of silica\* which is most commonly found in the form of hexagonal quartz. In this state the molecule is formed by a silicon atom, Fig. 1, surrounded by a tetrahedron of oxygen atoms. When the quartz is melted the atoms rearrange into a less orderly or random structure forming silica glass.

In the random structure, Fig. 2, all of the molecules are shown connected. However, in reality many of the oxygen atoms are not connected directly to a silica atom. This forms, according to Cameron, a terminal structure with voids which may be filled with ions, Fig. 2, such as sodium or potassium. The terminal structure affects the physical properties of glass fiber.

If a glass having a terminal structure has sodium ions in the voids these ions are not bound strongly to the silica structure. Since glass fibers are cooled very rapidly the molecular structure is frozen in an expanded state corresponding to the structure at some higher temperature. In this expanded state the sodium ions are subject to attack by moisture which enters the voids of the terminal structure. Thus the sodium reacts with water forming a gel which expands and weakens the glass.

---

\* Silicon dioxide,  $\text{SiO}_2$ , is commonly referred to as silica.

FIG.1  
SILICA TETRAHEDRA

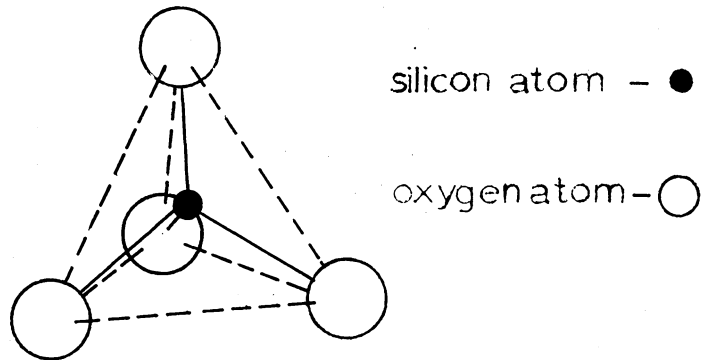

Three dimension sketch of  
silica tetrahedra.

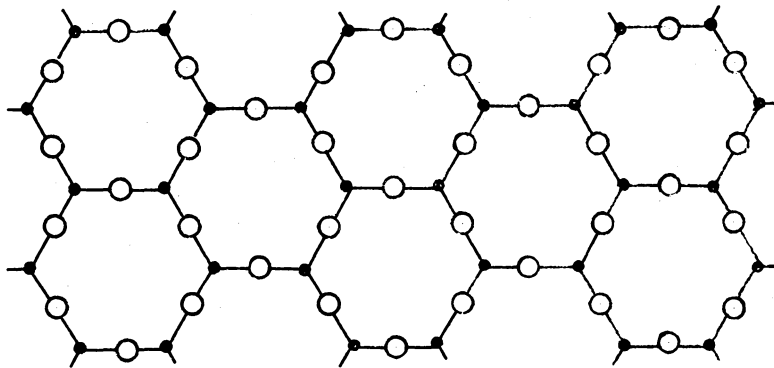

Two dimension sketch of  
silica structure.

FIG. 2  
OPEN STRUCTURE OF GLASS

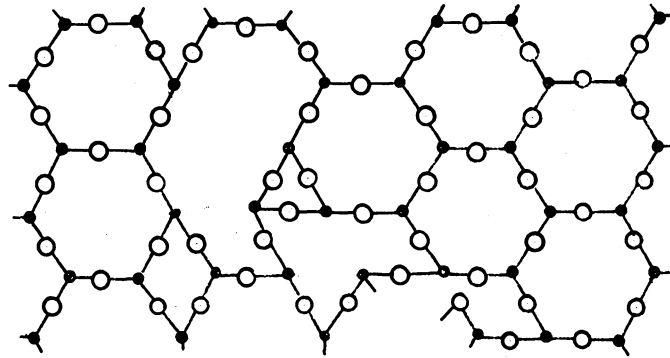

Open or random structure of glass.

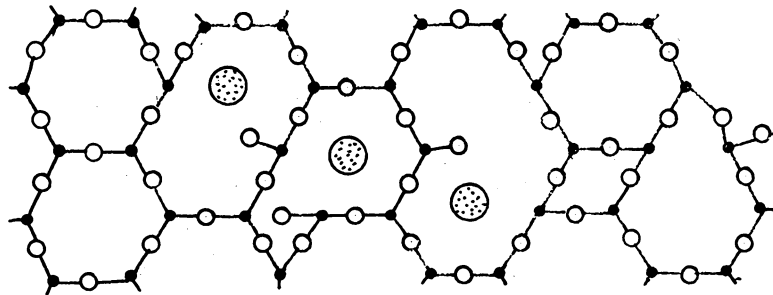

Terminal structure showing sodium ions in voids.

-- production of the fiber --

Although there are two methods used in forming glass fibers, the staple fiber process and the continuous fiber process, the latter will be described here.

When forming continuous glass fibers, bulk glass in the form of marbles is melted in a platinum crucible. The crucible has a nozzle through which 204 fibers of glass thread may be drawn.<sup>(17)</sup> When the glass is heated to melting temperature it begins to flow through the nozzle. The threads are then wound on rotating drums. The speed of the drum determines the diameter of the glass fiber. Usually all 204 fibers are wound together to form a single thread.

-- fiber strength --

Glass fibers have been produced in the laboratory with tensile strengths over 1,000,000 pounds per square inch. It is reported that commercial fibers are mass produced having strengths over 500,000 pounds per square inch.<sup>(4)</sup>

The strength of bulk glass is much less than the strength of glass fiber. This is explained by Cameron\*, as the result of two effects. First, the fiber structure and second the small number of flaws found in small volumes.

The structural difference between bulk glass and glass fiber is due to the rapid cooling of the fiber during

---

\* Ibid. reference (16), p.6

production. As the glass is heated the molecular structure rearranges itself from a crystalline form to a liquid form. When the fiber is drawn the glass cools from its melt temperature to room temperature in the order of  $10^{-5}$  seconds.\* This rapid cooling results in the glass fiber having a structure similar to that of glass at a higher temperature where the structure is expanded. Cameron suggests that anything which increases the distance between the silica and oxygen atoms may increase the strength of the glass fiber. This is due to the fact that when glass is in the expanded state the alkali present in the voids has less effect on the surrounding molecules. Since glass fibers are in the expanded state, this accounts for the increase in strength. Also, glass fiber in fiber glass is protected from the effect of moisture which protects the strength of the fibers.

Another structural difference is caused by the effect of drawing the fiber. Drawing the fiber tends to orient the strongest bonds between atoms in a direction parallel to the axis of the fiber and this results in an increase in strength.

Fiber strength is also related to the size and number of flaws in the glass. And, since the flaws in glass are related to volume it can be shown that as the fiber diameter decreases so does the number of flaws. This results in an increase of strength.

---

\* Ibid. reference (16), p.7

The strength of glass fiber is also related to the temperature of the melt from which the fiber is formed and the time of cooling. If the melt temperature is increased before drawing the fibers, any air bubbles in the molten glass can be removed easily thereby reducing the interior flaws. The only other flaws that may occur are on the surface. These surface flaws or cracks are formed when producing bulk glass. However, in forming glass fiber the extreme rapid cooling causes the glass to harden before surface cracks can form.

#### Properties of glass plastic materials

Among the first papers studied was a report<sup>(18)</sup> by the Battelle Memorial Institute on high temperature and creep rupture properties.

The investigations reported in this paper are a continuation of a study of elevated and room temperature properties of several plastic and resin-glass laminates. The study includes tensile and compressive creep studies and some short-time tensile testing.

Although many of the results were scattered and prevented a specific conclusion, the report points out one important fact. The tests show that short-time tensile tests give approximately the same strength relationship, for the materials tested, as do the normal creep rupture tests. The report

states that this may indicate short-time tensile tests could provide valuable information previously requiring years of careful laboratory work.

In 1954, Mr. Solomon Goldfein began publishing reports (19, 20, 21) dealing with predicting long-term test results from short-time tests at elevated temperatures.

By using the Larson Miller parameter<sup>(22)</sup>, Goldfein found that short time static tests lasting approximately two minutes gave satisfactory results for tests lasting as long as 20,000 hours. It was also found that creep properties, both tensile and flexural, of fiber glass laminates could be computed from modulus of elasticity data obtained at high temperatures.

As investigations continued on the properties of fiber glass laminates there were indications of deterioration of the plastic matrix under conditions of prolonged stress. It was known that some of the plastic materials, when used alone, were subject to stress cracking.

A report<sup>(23)</sup> issued in 1957 from the Picatinny Arsenal states that glass-polyester laminates would not stress crack when used in a stressed condition in an ordinary air atmosphere.

Even though stress cracking did not appear as detrimental as at first believed, other problems such as shear within the

matrix required study. The effect of shear within the plastic matrix of fiber glass has been reported by Rubinsky<sup>(5)</sup> and Maguire<sup>(13)</sup> as a cause of static fatigue. However, no solution to the problem of determining the effect or magnitude of shear was available.

In 1959, P. M. Goldfarb reported on methods being studied for determining the shear modulus of glass reinforced plastic laminates.<sup>(24)</sup> Three methods were reported to have been found which gave comparable results.

The last paper studied with respect to fiber glass was an article by Mr. Goldfein.<sup>(25)</sup>

Mr. Goldfein, investigating a formula for creep and rupture stresses, gives supporting data for his previous work and develops a parameter for use in predicting rupture and creep properties. This parameter was used, with other data from tests on different plastics and fiber glass material, to plot master curves from which creep and rupture properties were predicted. The predicted properties were for time periods from 0.01 seconds to 40,000 hours. High accuracy was obtained by this method for the materials investigated.

### Conclusions

From the papers reviewed the following conclusions are drawn:

1. The high strength to weight ratio, low elastic modulus, and the availability of raw materials justify the study of fiber glass prestressed concrete.

2. Fiber glass rods bonded with synthetic resin are superior to other products. The parallel fibers provide more even distribution of stress and therefore a stronger element than such products as woven rope or tape. Also the resin protects the glass fibers from moisture.

3. Sufficient bond can be developed between concrete and fiber glass rods to transfer stress from the rod to the concrete. However, more research is needed to develop an economical end grip capable of stressing the rods to their ultimate short time strength.

4. The property of static fatigue requires study to find how it occurs and the stress level below which it will not occur, should one exist. This study is necessary since the stress above which static fatigue occurs will dictate the allowable design stress. Indications are that a stress of less than 50 per cent of the ultimate short time strength will be necessary to eliminate static fatigue. Even so, the high strength to weight ratio should allow competition with modern steels.

5. Suitable end grips must be developed before considering fiber glass prestressed concrete as a competitor with

conventional prestressed concrete. To be suitable a grip must be capable of producing tensile forces within the fiber glass which exceed the tensile force at ultimate load.

6. It is necessary to determine reliable criterion by which members can be designed. Limits must be set on allowable working stress, load factors, and deflection - both at first crack and ultimate load.

7. The use of short time tests for predicting such properties as creep and rupture may provide answers to many questions previously unanswered. The limits on long time ultimate strength of fiber glass and the loss of prestress due to creep are the two most important values at this time.

## Investigation of Suitable End Grip

### Purpose of investigation

This investigation was conducted to determine if there were any practical gripping devices available which would provide sufficient anchorage for use in prestressing concrete with fiber glass.

The investigation was not intended to be an intensive study as to the best method of gripping fiber glass for prestressing. However, it was designed to aid in choosing a practical grip for use in prestressing beams analyzed in a later portion of this thesis.

### Plan of experimentation

At the present time most of the end grips available are designed to transfer tension in the rod to the concrete by compression and shear forces acting within the jaw assembly. Although many types have been tried, few are capable of practical application to fiber glass prestressed concrete because of size, weight or cost. The most promising exception to this is a grip, developed by Kenneth W. Keane, using a synthetic resin to bond the fiber glass to the metal.

Therefore end grips employing bond action between metal and fiber glass have been studied as well as devices used by the steel prestressing industry and the electric power industry for holding wire strands.

The grips are evaluated on the basis of results of tensile tests. The tensile specimens were tested in the Materials Testing Laboratory of Virginia Polytechnic Institute. The tests were run at atmospheric conditions with the load applied at a rate of strain of 0.05 inches per minute.

Due to the time involved only short time tests have been used to evaluate the grips. This should give accurate data since the ultimate long time effectiveness is believed to depend on a critical stress level rather than the mechanism holding the strand. However, in the case of an end grip using a bonding material the stability of the material under long time loading will be an important factor which is not considered in the present tests.

### Materials

-- supreme strand chuck no. 780 --

The Supreme Strand Chuck No. 780, Fig. 3a, is a grip commonly used in prestressing steel cable. Three of the grips were given by the Supreme Products Corporation, 2222 South Calumet Avenue, Chicago 16, Illinois.

This grip consists of an outside barrel which holds a conical jaw assembly. A spring loaded cap forces the jaw assembly around the prestressing strand thus holding it until load is applied. Any tensile force applied to the strand tends to tighten the jaws.

FIG. 3

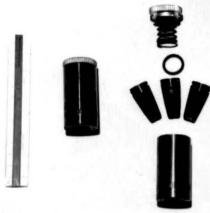

a. Supreme strand chuck

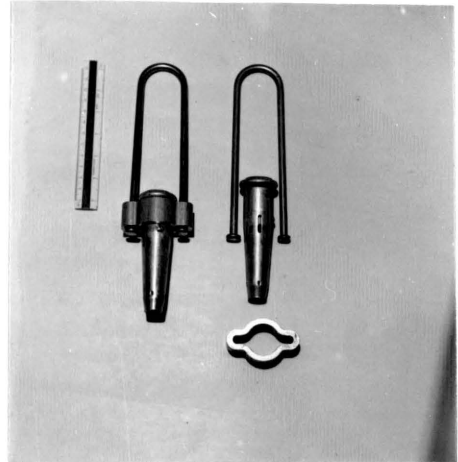

b. Reliable strandwise

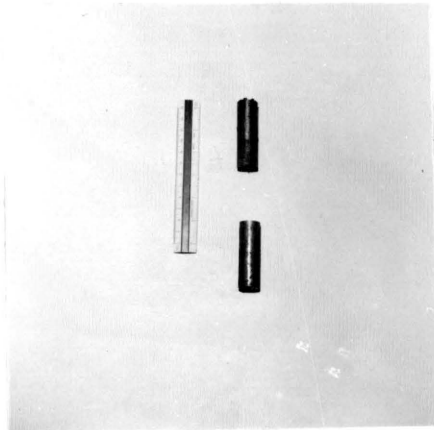

c. Tapered dowel

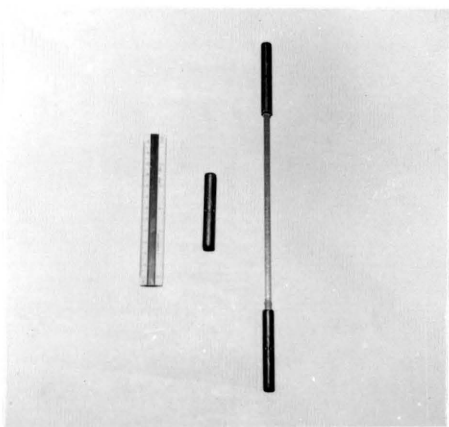

d. Reliable squeeze sleeve

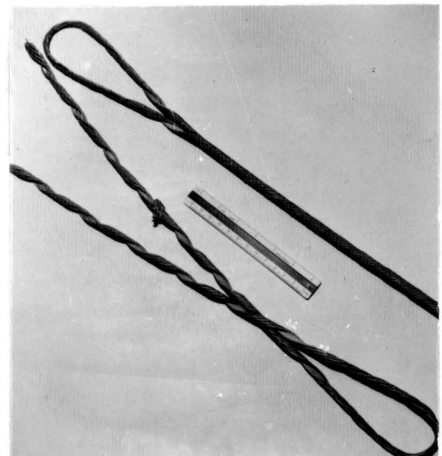

e. Fanngrip

-- reliable strandwise no. 5102 --

The Strandwise is a grip used in the electric power industry for holding cable. It is composed of a conical steel shell inside of which is a spring loaded jaw assembly.

To fasten the grip to the fiber glass rod the end is forced into the end of the grip. When the rod enters the jaw assembly it is held firm by the wedge action of the spring loaded jaws.

The Strandwise is designed to hold 10,000 pounds.

-- tapered dowel --

This grip is fashioned after similar grips made at Princeton University. The grip is made from a steel dowel. The dowel is drilled through the center and then the inside is tapered to form a conical shaped interior.

The fiber glass rods were split into four sections, Fig. 4, for a length of approximately two and a half inches. The sections were then wedged apart with short pieces of wire and the expanded end thus formed was bonded to the conical shaped grip using an epoxy resin.

Two types of resins were used during the tests:

1. Hysol Epoxi-Patch Kit, produced by Hysol Corp., Olean, New York.

FIG. 4  
PREPARATION OF TAPERED  
DOWEL END GRIP

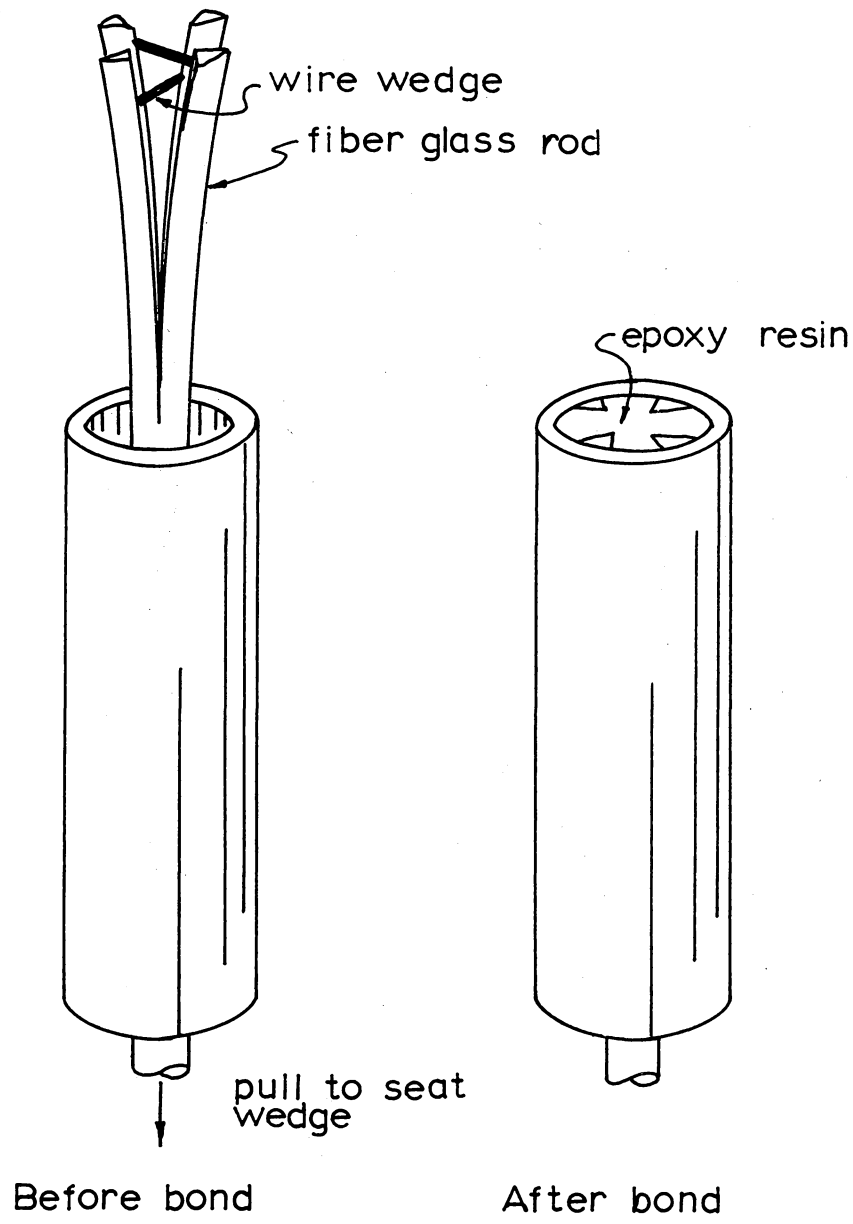

2. Marson's G-15 Epoxy Resin, produced by Marsons Corp., Revere, Mass.

-- reliable squeeze sleeve --

The Reliable Squeeze Sleeve is made by the Reliable Electric Company. The sleeve is copper having an inside diameter slightly larger than 1/4 inch. The inside of the sleeve is coated with a fine abrasive to improve the holding capacity of the sleeve. Inside the sleeve is a center stop which was removed by drilling before being used.

The grip is fastened by placing the rod inside and squeezing the sleeve.

-- fanngrip --

Fanngrips are made by the Fanner Manufacturing Co., Brookside Park, Cleveland 9, Ohio. The Fanngrip is normally used as a dead end for wire cable.

This grip is formed of pre-formed high tensile steel wires, Fig. 3e, which are wound in the shape of a helix. The wires are so shaped that when wound around each other they form a hollow cable. The inside surface of the cable is coated with a fine abrasive.

The Fanngrip is fastened to the fiber glass by wrapping the two ends around the fiber glass rod.

## -- fiber glass --

Fiber glass rods used in these tests were produced by the Columbia Products Company of Columbia, South Carolina. The rod stock was 1/4 inch diameter by ten feet long. All tensile specimens were cut from these ten foot lengths.

The glass fiber in the rods is made of boro silicate glass which is low in alkali content. The individual fibers are approximately 0.00036 to 0.00040 inches in diameter and are wound in a twelve strand roving. An 801 silane type binder is sprayed on the fibers to help bond the glass and epoxy resin. (17)

Shell Epon 828, epoxy resin, cured with Shell agent "Z" is used to bond the glass fibers forming the rod.

After the rod is moulded it is wrapped in cellophane and cured at 200°F for four hours.

The finished product contains 75 per cent glass by weight or 50 by volume and is reported to have an ultimate strength of 150,000 pounds per square inch.

Procedure and results

All of the end grips were tested in the same manner, the only difference being the method of placing the grip on the fiber glass.

After fastening the grips to the fiber glass the specimens were placed in a testing machine and loaded in tension until failure. The load was applied at a standard rate of strain<sup>(26)</sup> of 0.05 inches per minute.

Since the tests were all conducted using the same type fiber glass and at the same rate of loading the only other variables influencing the strength of fiber glass were temperature and humidity. However, this should give results approximating field conditions since these two factors are not normally controlled during construction.

Results of tests on the various end grips are discussed in the following paragraphs.

-- supreme strand chuck no. 780 --

In all of the tests conducted on this grip failure occurred within the jaw assembly as a result of crushing and/or cutting caused by the serrated face of the jaw assembly. Due to the type of failure some tests were made using a soft copper sleeve to cover the fiber glass to protect the surface.

The copper sleeves were made of standard copper pipe with a section cut out so that a tight fit would be obtained. Before placing the sleeve on the rod a fine coating of carborundum powder was placed on the surface of the rod to improve the resistance to slippage. A small amount of Duco Cement was used to hold the carborundum powder in place.

Although this procedure improved the capacity of the grip, failure still occurred due to crushing and/or cutting action of the serrated face on the jaws.

Examination of the failures showed that the leading edge of the jaw assembly had been forced into the rod. To eliminate this the jaws were altered to provide a more even bearing surface.

Alterations to the jaws were made by removing the teeth on the leading edge, Fig. 5, and removing the outer face for about 1/2 inch. These changes moved the centroid of the compressive force toward the back of the grip, therefore relieving part of the pressure on the forward edge. As a further precaution, the fiber glass was coated with carborundum and fitted with a copper sleeve.

This revised grip held a tensile force of 4,750 pounds. However, failure occurred within the grip itself. Failure was due to crushing of the fiber glass.

-- strandwise no. 5102 --

Since this grip has a jaw assembly much like the Supreme Strand Chuck, a soft copper sleeve was used to protect the fiber glass. The Strandwise will hold strands 3/8 inch to 11/32 inch in diameter. Therefore, there was sufficient clearance for placing the sleeve around the fiber glass rod.

In all of the tests with this grip the fiber glass rod slipped out of the sleeve.

FIG. 5  
JAW ASSEMBLY  
SUPREME STRAND CHUCK

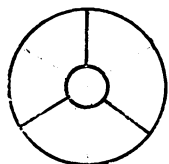
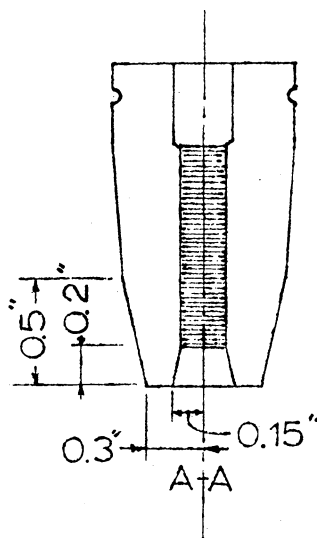
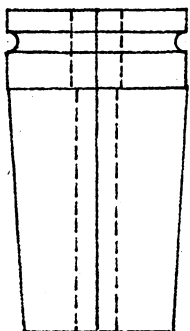
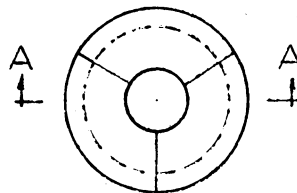
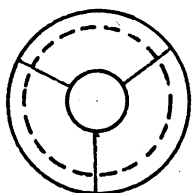

original

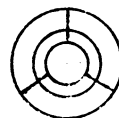

revised

scale 1=1

## -- tapered dowel --

The Tapered Dowel was made from one-inch diameter rod stock. Two three-inch lengths were cut and drilled with a 0.261 inch hole to allow free passage of the 1/4 inch fiber glass rods. The inside of the grip was tapered to form a wedge for securing the end of the fiber glass.

After the fiber glass rod was prepared by splitting the end and wedging the sections apart, the epoxy adhesive was placed in the grip, Fig. 6, to form the completed grip.

The specimen was then placed in a special jig for curing. Specimens were allowed to cure not less than 24 hours at room temperature.

The first test gave tensile strengths over 5,000 pounds. However, failure occurred within the grip. This indicated that full tensile strengths were not being developed. In all cases failure was sudden. Examination of the grip showed the point of failure to be where the taper began. To eliminate this the grip was reamed to form a smooth transition from taper to the centerhole.

Tests performed on this revised grip indicated no apparent improvement over previous tests.

Due to the brittle fracture noted in the Hysol Epoxy, which was used on the previous tests, a different epoxy was tried. This was done to determine whether the bonding material influenced the strength of the grip.

FIG. 6  
TAPERED DOWEL GRIP  
AND  
CLAMP

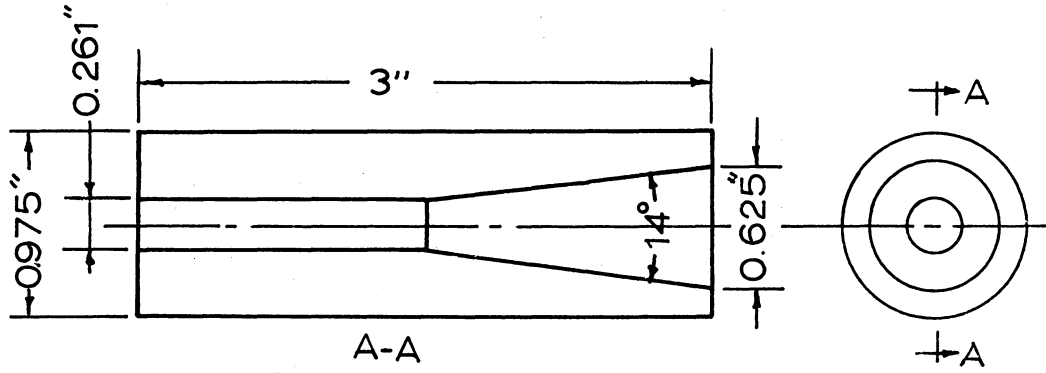

A-A  
Tapered dowel grip  
scale: 1" = 1"

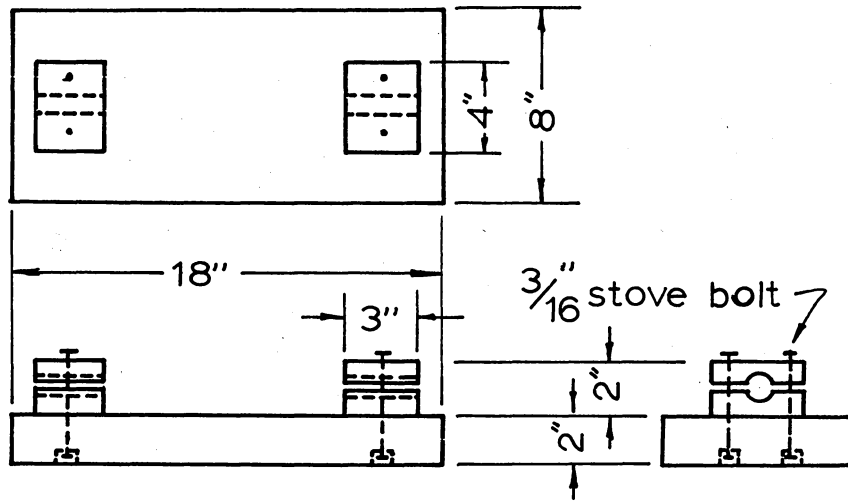

Clamp  
scale: 1/8" = 1"

Marson's G-15, epoxy resin, was mixed in the proportion of four parts resin to one part hardener. Before placing the epoxy into the grip heat was applied using an infrared lamp. The resin was then poured into the grip and heating was continued until the epoxy began to set.

Two tests were performed using the G-15 epoxy. Tensile strengths of 8,625 pounds and 9,400 pounds were recorded. The test having the smaller strength was made before complete cure of the resin. This was done through an error in mixing the materials which caused a slow cure. The second test was the first to approach the ultimate short time tensile strength of the fiber glass rods.

-- epoxy and squeeze sleeve --

Due to the good results, obtained with the tapered dowel, using the G-15 epoxy, several tests were made using the epoxy to bond a Reliable Squeeze Sleeve. In these tests the sleeve was not crimped.

After placing the sleeve over the fiber glass, the G-15 epoxy was poured into the open space and cured as described for the tapered dowel.

The specimen was placed in the testing machine and loaded until failure. Failure occurred at 5,580 pounds as a result of the rod slipping out of the grip.

## -- fanngrip --

The Fanngrip was placed on the fiber glass rod by wrapping the helical strands around the rod. To wrap the strands the rod is placed inside the loop. Then the ends are pulled away from the rod and at the same time twisted in a clockwise direction. This forms a closely wound steel wire cover which tends to tighten around the fiber glass rod when tension is applied.

When applying the grip care must be exercised to keep the wire strands away from the fiber glass. Otherwise, the abrasive coating will cut the outer surface, thereby reducing the strength of the rod.

During the test the load was observed to increase steadily up to 6,200 pounds. At this load surface cracks appeared to be progressing longitudinally along the rod. Failure occurred at a load of 6,400 pounds and was accompanied by a sudden shattering of the rod. Examination of the specimen showed that some damage to the rod had resulted while fastening the grip.

Discussion of results

All of the various gripping devices can be divided into three different groups with respect to the method employed to transfer load on the grip to tension in the rod. These

groups are: compression and shear, direct bond, and wedge action. Results of the tests are listed in Table I.

-- compression and shear --

The grips included in this category are the Supreme Strand Chuck, the Strandvise, and the Fanngrip. Of these grips the Fanngrip proved most successful, providing a tensile strength of 6,400 pounds for a 1/4 inch fiber glass rod.

Although the tensile strength was within the range of tension expected in the prestressed beams, this grip was not considered for use due to the fact that permanent damage was done to the fiber glass while applying the grip.

Even though the Fanngrip was not used in further tests, this is not intended to indicate the grip is unsuitable for use with fiber glass. The Fanngrip is a simple, easily applied grip capable of transferring tensile forces as great or greater than any other mechanical grip known to have been used on fiber glass rods. If this grip were produced with a finer grained abrasive the damage to the rod during application would be reduced and the ultimate strength increased.

Test results indicate the Strandvise grip did not provide sufficient tensile strength to be considered for further tests. This may have been due to the type sleeve used. Since the sleeve was split it could only develop friction to hold the rod through compression in the jaw assembly. Therefore,

Table I  
End Grip Strength

Test Number*	Type of Grip	Failure	Load (lb.)
1	Supreme Strand Chuck	Grip	3,000
2	Supreme Chuck & Sleeve	Grip	3,755
3	Strandvise No. 5102	Grip	75
4	Supreme Chuck & Sleeve	Grip	4,750
5	Supreme Chuck	Grip	2,700
6	Tapered Dowel, Hysol	Grip	5,125
7	" " "	Grip	6,550
8	" " "	Grip	5,475
12	Epoxy & Squeeze Sleeve	Grip	5,580
13	Tapered Dowel, Hysol	Grip	5,420
14	" " , G-15	Grip	8,625
15	" " , G-15	Rod	9,400
16	Fanngrip	--	6,440

\* See Appendices for details of each test.

if the coefficient of friction between the sleeve and fiber glass was low, slippage would occur when the tensile force in the rod overcame the friction force in the grip.

The Supreme Strand Chuck, like the Strandvise, uses a jaw assembly to hold a tension element. All of the tests performed on this grip resulted in failure due to crushing the rod. This substantiates the findings of Rubinsky, Crepps, and Keane. A revision of the jaw assembly increased the load carrying capacity 1,750 pounds. However, this was still insufficient for use in prestressed beams.

-- direct bond --

Only one grip was tested which used direct bond of fiber glass to a metallic grip. This was the Squeeze Sleeve bonded with Marson's, G-15, epoxy resin.

This grip provided adequate strength to stress the fiber glass over 110,000 pounds per square inch before failure. Failure resulted from loss of bond.

It is evident that the load capacity of this type grip is a function of surface area over which bond occurs. Therefore, increased loads could be attained by using a longer grip. However, the stability of the grip over a period of time will depend on the properties of the bonding material.

If the bonding material is subject to creep or plastic flow under working loads, a complete loss of prestress could occur.

With this in mind, plus the fact that yielding was observed during tests, this grip was not considered for use in prestressing.

-- wedge action --

The tapered dowel end grip, designed after a similar device developed by John Weis at Princeton University, utilizes wedge action and bond to hold the fiber glass. This grip employs the desirable properties of both the epoxy bond and the wedge action found in the jaw assembly of most mechanical grips.

Due to the construction of the grip, failure by crushing is eliminated and loss of prestress due to creep of the bonding material is reduced.

Test results, Table I, indicate good tensile strengths can be achieved using this grip. Comparing results of tests using Hysol epoxy with tests using Marson's, G-15, the latter appears to form a superior grip. Grips using G-15 as a bonding material will hold approximately 9,000 pounds, an increase of almost 60 per cent over grips formed with Hysol epoxy.

An explanation for the difference in strength is the hardness of the epoxy. The Hysol epoxy, when hard, is a very brittle material. On the other hand, the G-15 forms a hard, tough material when cured properly. The result of this difference is that the G-15 will allow an even distribution of

load while the Hysol epoxy causes stress concentrations and therefore premature failure within the grip.

Before this type of grip can be evaluated properly a study should be made using many different bonding materials.

There are several disadvantages to the tapered dowel grip. These include the time factor involved in preparing the grip and the grip is not recoverable.

The most significant advantages of the grip are its reliability in reproducing results, the high tensile strength obtained, and the fact that little damage is done to the fiber glass rod when applying the grip. For these reasons the tapered dowel grip was selected for use in prestressing test beams.

### Conclusions

1. The development of a practical end grip is one of the largest single factors preventing the development of fiber glass prestressed concrete.
2. Although relatively few tests were conducted to determine the existence of a practical gripping device, indications are that none of the grips tested are suited for use. It can generally be said that the grips are unsuitable because they do not provide adequate tensile strength. Also, the economics involved in production rule against their use.

3. With respect to the mechanical grips employing a jaw assembly, the combination of compressive and tensile stresses cause premature failure within the grip. If a mechanical grip were designed, giving careful attention to the distribution of compressive forces acting on the fiber glass, an effective end grip may result.

4. The most effective grip tried with regard to holding strength, time and ease of application, and cost, is the Fanngrip. This grip has all of the desirable properties not found in other mechanical grips. The load is transferred from grip to fiber glass gradually so no highly stressed portion will crush the rod. Also the compressive stress is minimized due to the fact that no initial compression is required to hold the fiber glass.

## Design and Investigation

### Purpose of investigation

Although there have been tests conducted on fiber glass prestressed concrete beams, most of the testing has been directed toward studying fatigue in the fiber glass and studying prestressing systems. Few, if any, tests have been made to check the adequacy of design concepts, presently used for conventional steel prestressed concrete, as applied to fiber glass.

This investigation is made to determine if current design procedure is acceptable for fiber glass prestressed concrete.

### Plan of experiment

The tests were to be performed on simply supported beams loaded at the third points. Measurements of strain were to be taken on the top and bottom flange of the concrete and also on the fiber glass.

Since the beam was designed using conventional steel prestressed concrete procedure, the test results should correspond to the calculated stress if the theories are valid.

Before a design could be made, the physical properties of the fiber glass had to be determined. The most important properties, ultimate short-time strength and elastic modulus,

were determined during the study of a suitable end grip. Although other properties such as bond strength, creep, and static fatigue are of concern, these were essentially eliminated when the post-tensioned beam was selected.

By post-tensioning the beam the elastic movements of both concrete and fiber glass would be completed during the stressing operation. This eliminates loss of prestress due to elastic movements. The problem of bond was avoided by leaving the open duct ungrouted, and since the duct was straight the losses due to friction were negligible. Creep and static fatigue were also neglected since all of the available data indicate these to be of no concern when stresses are kept below 50 per cent of ultimate.

#### Properties of fiber glass

To determine the elastic properties of the Columbia\* fiber glass rods stress strain data were recorded during tensile tests. Due to the high strain to stress ratio post yield strain gages were placed, Fig. 7a, on the fiber glass to record strain. The gages used were PA-3, special purpose gages. They were fastened to the specimen with post yield cement No. 103173. Both the gage and the cement are products of the Baldwin-Lima-Hamilton Corporation.

---

\* The fiber glass rods used for post-tensioning beams were supplied by Columbia Products Company, Columbia, S.C.

FIG. 7

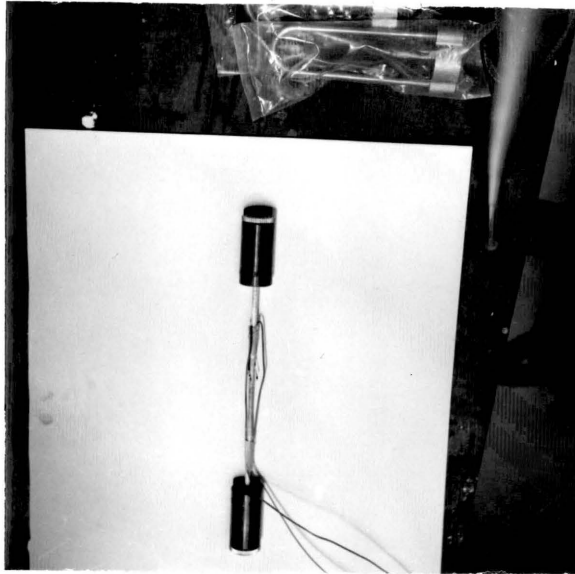

a. Post Yield Gage on Specimen

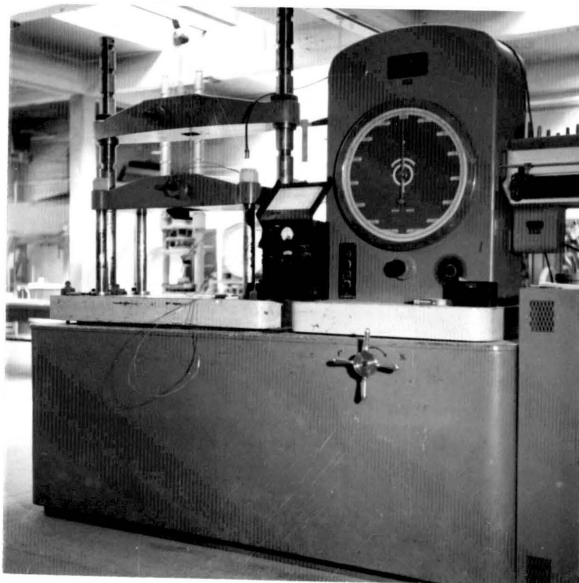

b. Setup for Tensile Test

The tensile specimens were placed in the testing machine, Fig. 7b, and loaded at a uniform rate of strain equal to 0.05 inches per minute until failure. Tests 5a through 5d, Table II, were made using a mechanical strain indicator coupled to an automatic recording device. Values for elastic modulus of these tests were calculated from the recorded graph.

All of the stress strain data show linear relationships, Fig. 8, throughout most of the curve. However, Test No. 15, which was the only test where stress strain data were recorded above a stress of 110,000 pounds per square inch, shows a non-linear relationship in the upper region of the curve.

An average value of elastic modulus is  $6.68 \times 10^6$  p.s.i. and the ultimate short-time tensile stress is taken to be around 180,000 pounds per square inch or higher.

#### Design of post-tension beam

The beam was designed by selecting a cross-section, Fig. 9, and checking the initial and final stress conditions. The final design was a seven foot "I" beam designed for a clear span of six feet to be loaded at the third points.

A design cracking load was calculated as 3242.6 pounds when using a prestressing force of 5000 pounds. Values of the compressive and tensile strength of concrete were determined from laboratory tests. The method of calculation may be found in the appendices.

Table II

Table of Ultimate Stress and Elastic Modulus  
for 1/4 Inch Diameter Fiber Glass Rod

Test No.	Failure Location	Ultimate Load (lb.)	Ultimate Stress (psi)	Elastic Modulus (psi)
5a	Grip	1500	--	--
5b	"	2700	--	$6.74 \times 10^6$
5c	"	1100	--	$6.45 \times 10^6$
5d	"	1500	--	$6.80 \times 10^6$
8	"	5475	113,000	$7.10 \times 10^6$
9	"	1500	82,000	$6.15 \times 10^6$
14	"	8625	164,000	$6.43 \times 10^6$
15	Rod	9400	180,000	$7.10 \times 10^6$
16	Grip	5425	104,800	$6.45 \times 10^6$

FIG. 8  
TYPICAL STRESS STRAIN CURVE  
TEST NO. 8

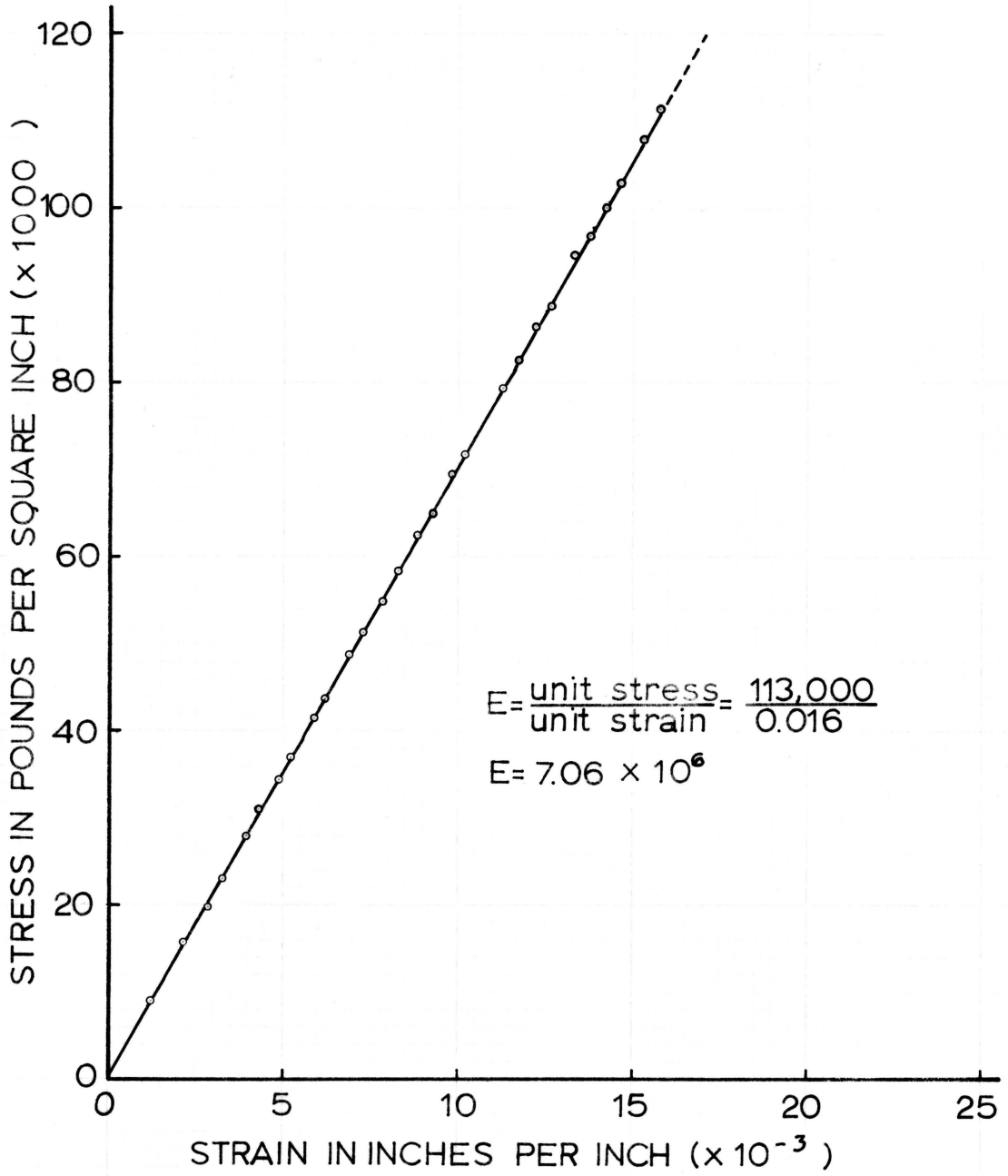
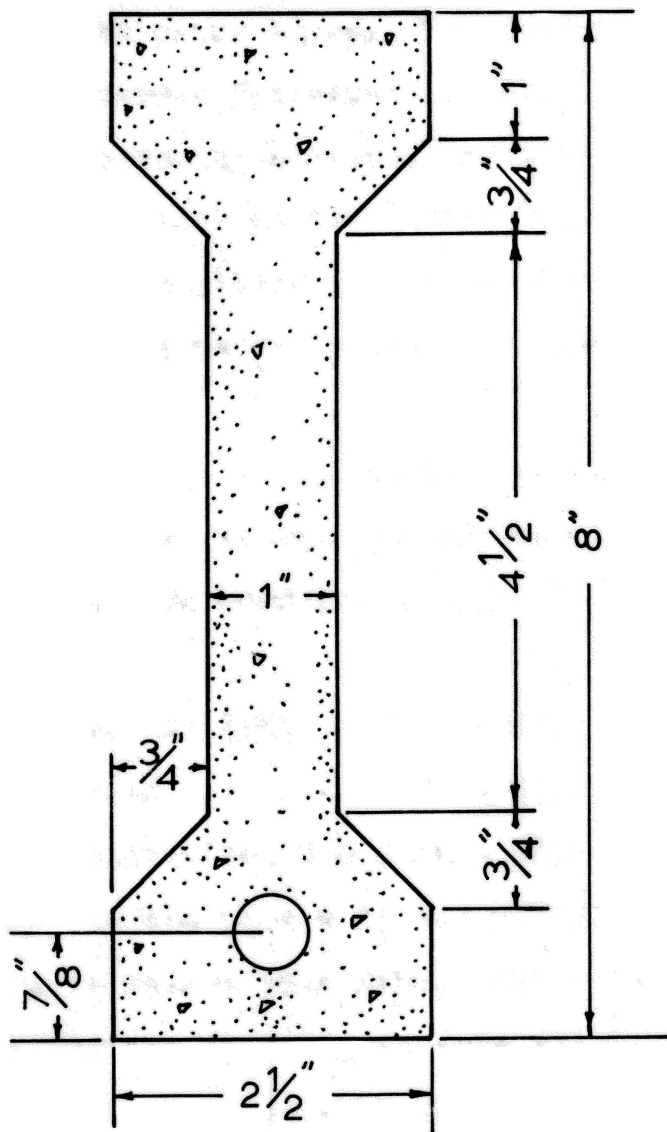

FIG. 9  
CROSS SECTION OF BEAM



scale:  $\frac{2}{3}'' = 1''$

### Fabrication

Concrete beams, Fig. 10a, were made in a form, Fig. 10b, designed so that two members could be cast at one time.

The open duct, through which the tension element was placed, was formed with paper tubes. The tubes, donated by Virginia Prestress Concrete Corporation, were the type used to break bond on prestressing strands, and they were coated with paraffin for protection against moisture. A number three steel reinforcing bar was placed in the open tube while pouring concrete. This was done to insure that the opening remained straight.

The concrete mix used for the beams was taken from a book<sup>(27)</sup> published by the Portland Cement Association. The following proportions were used for a cubic foot of concrete:

water	- 12.4 pounds
cement, Type III (AE)	- 27.2 pounds
limestone sand	- 54.8 pounds
limestone aggregate, 3/4 down	- 54.8 pounds

When the concrete was placed it was vibrated, with an electric vibrator, to reduce honeycomb. The beams were then covered with polyethylene sheeting to cure for three days. After curing, the forms were removed and the beams were stored at atmospheric conditions until testing.

FIG. 10

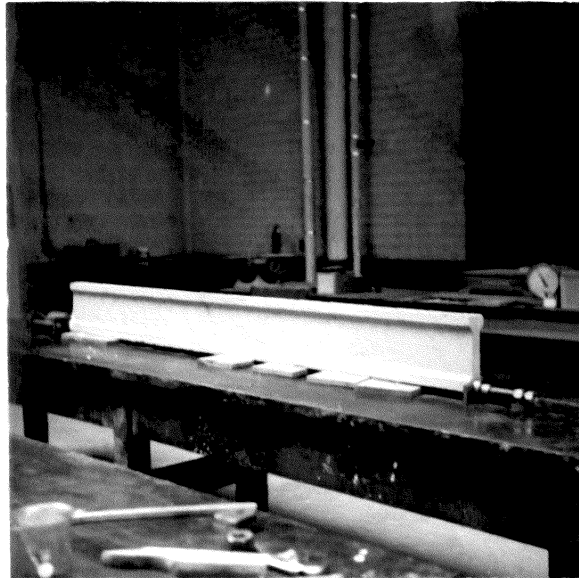

a. Test Beam

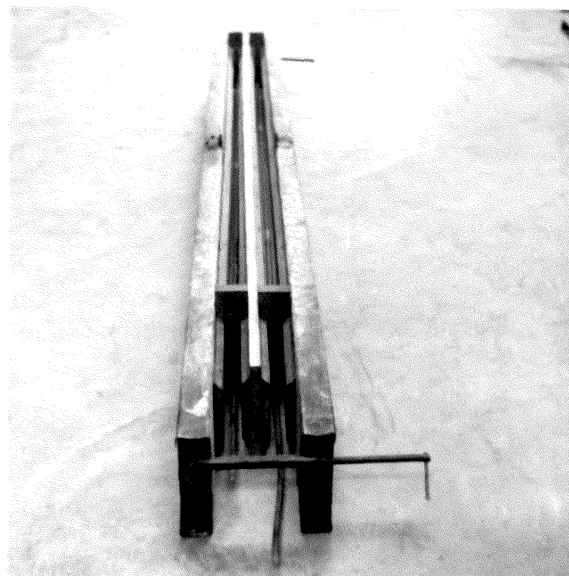

b. Beam mould

Due to the success obtained with the tapered dowel end grip, this grip was used to post-tension the test beams. A tensioning device, Fig. 11a, which includes the end grip was designed to stress the post-tensioned members.

The fiber glass rod was stressed by turning, Fig. 11b, the tension\* nut. This forces the end grip away from the member and places the fiber glass in tension.

On the end opposite the tension device a tension indicator, Fig. 12, was placed to record tension in the fiber glass during the initial stressing and also during the tests. The tension indicator\* was composed of a load cell and an end grip. The end grip was threaded to fit inside the load cell. The load cell was then fastened to a frame which fit on the end of the beam.

The end grips were placed on the fiber glass 24 hours before testing.

### Test procedure

Since the purpose of testing the beams is to check the design calculations against test results it was necessary to record stress and strain data during the post-tensioning of the member as well as during the test.

---

\* Details of the tension device are shown in Fig. 23.

+ Details of the tension indicator are shown in Fig. 24.

FIG. 11

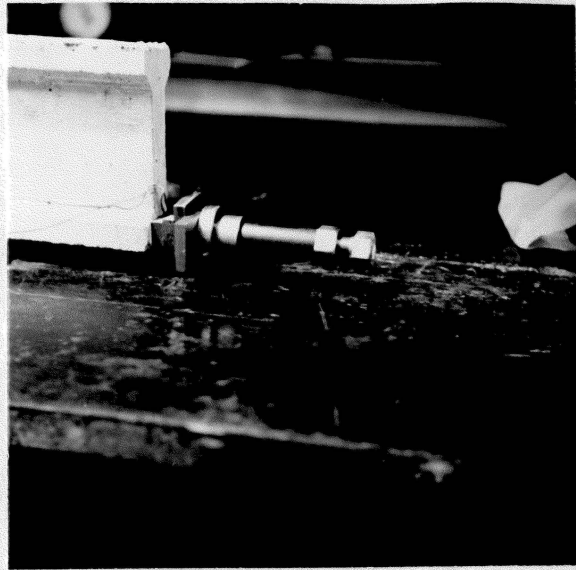

a. Tensioning Device

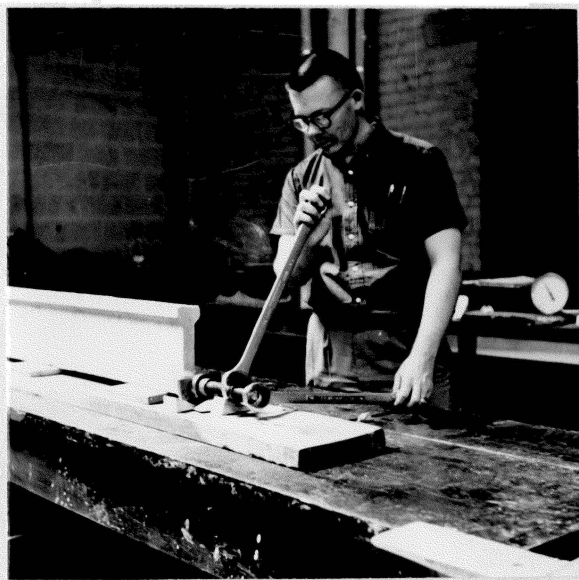

b. Method of Tensioning

FIG. 12



Tension Indicator

To record data, strain gages were fastened to the center of the top and bottom flange. A strain gage was also fastened to the fiber glass rod.

As the beams were stressed data were recorded to show the tension in the fiber glass and strain in the concrete. When the tension in the fiber glass reached the design value the post-tension operation was complete. The beams were then placed in the testing machine.

The equipment setup for recording data during the post-tension operation and the beam test are shown in Fig. 13a and 13b, respectively.

During the beam tests the load was applied in 200 pound increments. Readings of total load, center line deflection, concrete strain, and fiber glass strain were recorded at each load increment until the member cracked. After the beam cracked the only significant data were deflection, fiber glass strain, and total load. These data were recorded until failure of the beam.

#### Critical loads and deflection

When designing a prestressed member the load and deflection are often important depending on its type and function. Several important stages in loading a beam are the design load, the cracking load, and ultimate load. Both load and deflection should be checked against allowable values.

FIG. 13

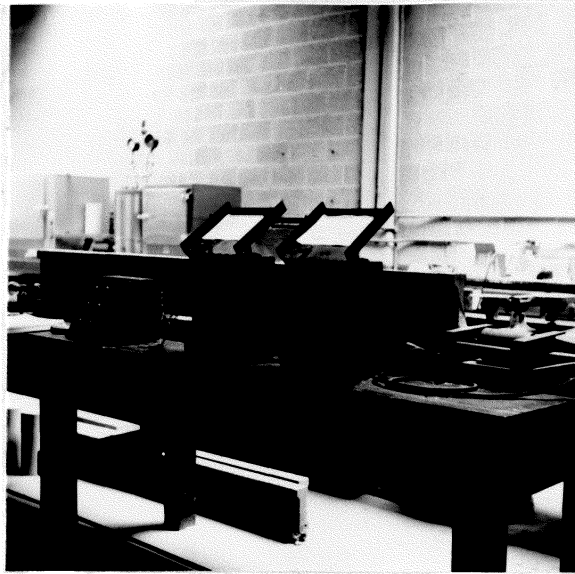

a. Equipment setup for Post-tensioning

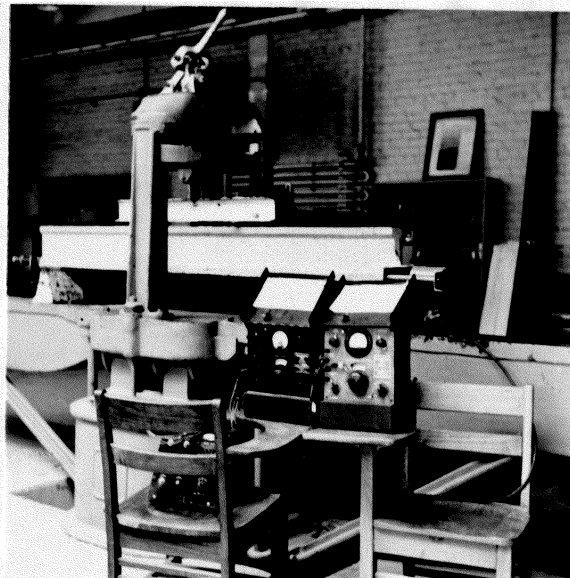

b. Equipment Setup for Beam Tests

Since there was no reason to believe the design or working load and deflection would be different from values calculated for an equivalent steel prestressed member, it is assumed that a similar procedure could be used in each case. However, as a beam approaches the ultimate load the situation is quite different from that of an equivalent steel prestressed beam.

As a steel prestressed beam reaches the ultimate load the steel cable is stressed to yielding. This allows the designer to calculate the compressive area of concrete and the ultimate moment. Knowing the ultimate moment the ultimate load can easily be calculated.

It has been shown that fiber glass has no yield point. Therefore, when trying to calculate the ultimate load, the designer does not know the stress in the fiber glass. As a result of this unknown the ultimate moment cannot be determined.

Calculations of deflection at ultimate and cracking load are taken after the work of George C. Ernst.<sup>(28)</sup> Two equations were developed after revising the first and second moment area theorems.\* These equations are:

$$\begin{aligned} \text{deflection at crack, } \Delta_c &= 23/216 \phi_c L^2 \\ \text{ultimate deflection, } \Delta_u &= \left( \frac{\phi_c}{27} + \frac{5}{72} \phi_u \right) L^2 \end{aligned}$$

---

\* The revised moment area theorems and the development of the two basic equations is shown in the appendices.

where:  $\phi_c =$  rotation at first crack  $= \frac{\xi_c + \xi_t}{d}$

$\phi_u =$  ultimate rotation  $\frac{\xi_c f_{av}}{dp f_g}$

To arrive at a working equation for deflections the equations for  $\Delta_c$  and  $\Delta_u$  were rewritten.

Rewriting the expression for unit rotation:

$$\phi_c = \frac{\Delta_f}{E_c d} \quad \text{where: } \Delta_f = f_{ti} - f_{tf} + f_{bf} - f_{bi}$$

In this equation  $E_c$  is the modulus of concrete and  $\Delta_f$  is the total change in concrete stress between bottom and top flange and from initial prestress to the load condition for which the deflection is desired.

Since all of the quantities required to calculate  $\Delta_f$  are known during the design, the deflection at first crack can be found. Assuming the modulus,  $E_c$ , to equal one thousand times the compressive strength of the concrete, the deflection at first crack is:

$$\Delta_c = \frac{23}{216000} \frac{L^2}{d f_c'} \Delta_f$$

Using the same procedure the equation for ultimate deflection is rewritten as:

$$\Delta_u = \left( \frac{\Delta_f}{27000 f_c'} + \frac{5 \xi_c f_c'}{72 p f_g} \right) \frac{L^2}{d}$$

In this equation the value of  $\epsilon_c$  is the failure strain of concrete and may be assumed to be 0.003 inches per inch. This leaves one unknown term, the stress in the fiber glass at ultimate load. Due to the low modulus of elasticity of the fiber glass, sufficient yield should occur in an unbonded post-tensioned member to cause a compressive failure in the concrete with only a small increase in fiber glass stress. For this reason only a slight error is introduced if the initial post-tensioning stress is used in the deflection equation.

The equations developed for deflection are for short time loads. Deflections under long time loading can be calculated by substituting  $0.85 f_c'$  for  $f_c'$  in the expression for ultimate rotation and substituting  $500 f_c'$  for the modulus of concrete in the expression for rotation at first crack. The ultimate deflection is then:

$$\Delta_u = \left( \frac{\Delta f}{13500 f_c'} + \frac{4.25 \epsilon_c f_c'}{72 p f_g} \right) \frac{L^2}{d}$$

### Discussion of results

The results obtained in the tests correspond well with the calculated values of cracking load and deflection. Data recorded during the test were:

Beam No.	Initial Prestress (lb.)	Cracking Load (lb.)	Deflection at Cracking Load (inches)	Ultimate Deflection (inches)
1	4570	2000*	0.045	1.23
2	5620	3400	0.055	--+
3	5585	3400	0.060	1.25

If the measured value for initial prestress is used in the design calculation the following theoretical values are obtained:

Beam No.	Cracking Load (lb.)	Deflection at First Crack (inches)	Ultimate Deflection (inches)
1	1957	0.037	1.46
2	3100	0.059	1.56
3	3190	0.066	1.57

Comparing the above results with design values above, the design deflection is about 25 per cent higher. This is due to the use of the initial post-tension force in calculating the final fiber glass stress. Since the initial stress is the lower, the calculated deflection is larger than it would be if the actual value were used. Using beam No. 3 as an

\* This beam not loaded to failure.

\* Beam No. 1 was cracked during fabrication. The cracking load was measured when the crack first became visible.

example, and substituting the actual final fiber glass stress, 123,000 psi, into the ultimate deflection equation, the deflection is 1.31 inches. This is within 10 per cent of the measured deflection.

The test results indicate that fiber glass post-tensioned concrete members may be designed by existing theories except for finding ultimate loads.

A plot of load and deflection, Fig. 14, shows that after the post-tensioned member cracks, very little increase in load occurs before failure. After the first crack deflections increase rapidly.

Due to the apparently small safety factor between cracking and ultimate loads a suitable safety factor must be found which would insure against cracking. This may be accomplished by designing according to section 205.2 of the present code.<sup>(29)</sup>

### Conclusions

Considering test results of beams designed by presently acceptable theories, the following conclusions are made:

1. Design concepts used with conventional steel prestressed concrete are adequate for fiber glass post-tensioned concrete, up to the cracking load. There is also no indication that fiber glass prestressed concrete will require changes in design procedure.

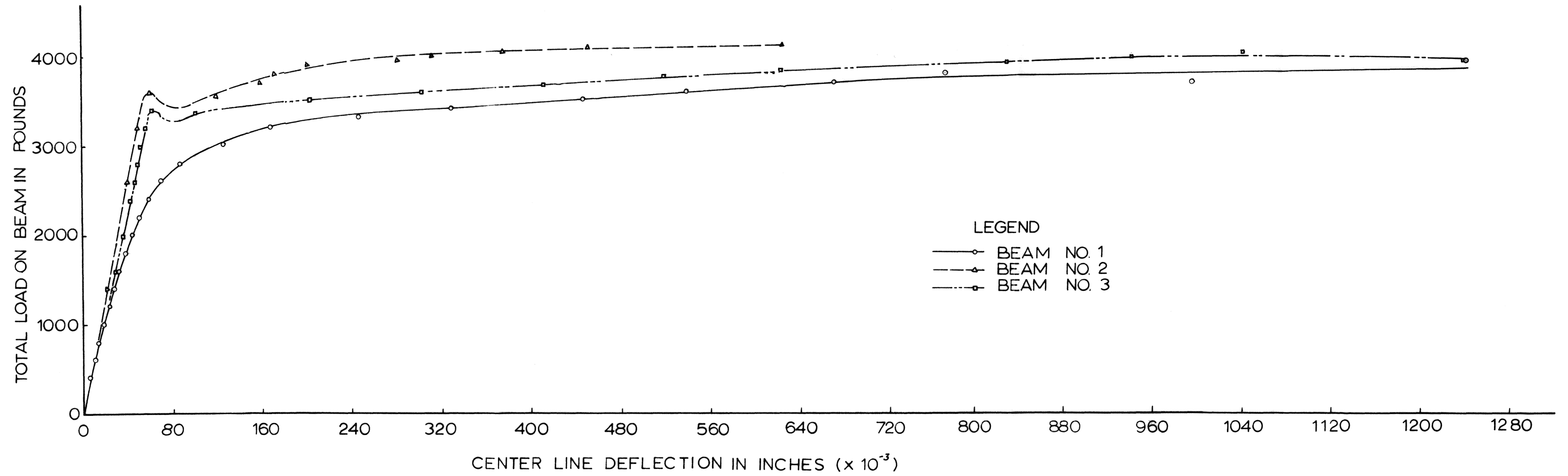
FIG. 14  
LOAD DEFLECTION CURVES

2. Excessive deflection will not become a problem as long as working loads are maintained below the cracking load.

3. Deflections computed according to the revised moment area theorems appear to correlate well with actual deflections. However, these equations should be checked with many different designs to determine their adequacy.

4. A method of calculating ultimate loads must be studied before reliable safety factors can be chosen to insure against failure.

## VI. APPENDICES

Design of Post-tension Beam

For the design of a member it was necessary to know the value of  $f_c'$  and  $f_t'$ . These values were determined from tests of standard cylinders and flexural beams. The beams used to determine  $f_t'$  had the same cross-section as the actual member. The values used for design purposes were:

$$f_c' = 4,341 \text{ psi and } f_t = 645 \text{ psi}$$

The beam was designed by choosing a cross-section and checking the stress at various load stages. Calculation of design load and stress are as follows:

$$\text{Stress in concrete, } f_c = -\frac{T}{A_c} \pm \frac{T e_c}{I} \pm \frac{M_{DC}}{I} \pm \frac{M_{LC}}{I}$$

The beam properties are shown in Fig. 15, and also the method of loading.

The moments  $M_D$  and  $M_L$  taken at the centerline are:

$$M_D = 1/8 wL^2 = 734.4 \text{ in. lb.}$$

$$M_L = \frac{P}{2}x = 12 P \text{ in. lb.}$$

Using  $T = 5000 \text{ lb.}$ , the equation for concrete stress in the top and bottom flange respectively become:

$$f_t = +327.5 - 0.537P - 32.84$$

$$f_b = -1110 + 0.55P + 33.67$$

FIG. 15.  
BEAM PROPERTIES AND LOADING

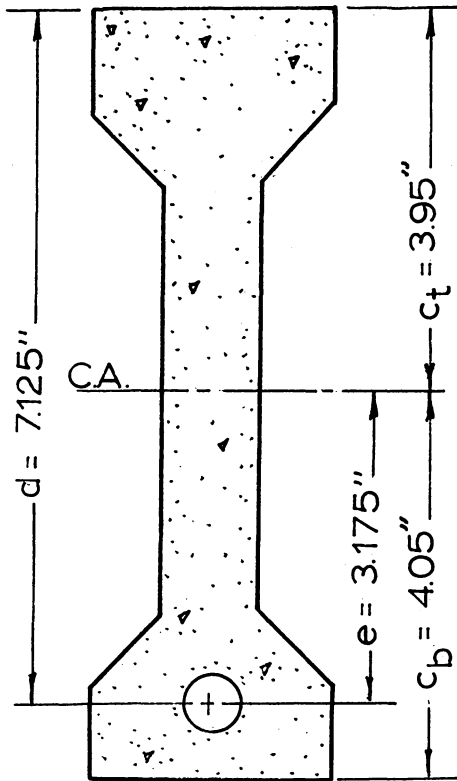

$$A_c = 13.08 \text{ sq. in.}$$
$$A_g = 0.052 \text{ sq. in.}$$
$$I = 88.69 \text{ in.}^4$$
$$p = 0.00398$$

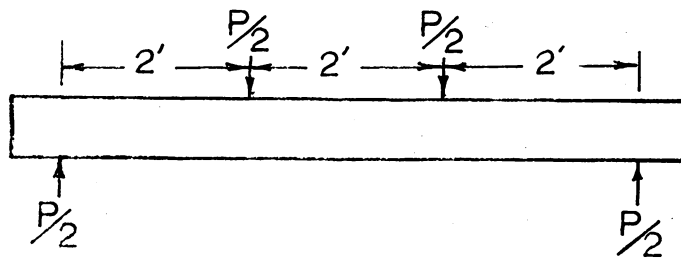

Now if the limit values of  $f_c'$  and  $f_t'$  are substituted into the above equations, the cracking load,  $P_c$ , is found to be:

$$P_c = 3242.6 \text{ lb.}$$

Values for the initial stress at zero load and final stress at cracking load are found to be:

$$f_{ti} = + 294.7 ; f_{tf} = - 1446.6$$

$$f_{bi} = -1076.3 ; f_{bf} = + 707.1$$

Deflections are calculated by equations developed from the revised moment area theorems. These equations are:

$$\Delta_c = \frac{23}{216000} \frac{L^2}{d f_c'} \Delta f, \text{ and}$$

$$\Delta_u = \left( \frac{\Delta f}{27000 f_c'} + \frac{5 C_e f_c'}{72 p f_g} \right) \frac{L^2}{d}$$

Where  $\Delta f = f_{ti} - f_{tf} + f_{bf} - f_{bi}$  is obtained from previous calculations. Substituting the proper values the design deflections are:

$$\Delta_c = 0.053 \text{ inches}$$

$$\Delta_u = 1.61 \text{ inches}$$

Development of Deflection Equations  
from Revised Moment Area Theorems

A method of computing deflections was taken after the work of George C. Ernst<sup>(28)</sup> who revised the moment area theorems to derive ultimate slope and deflections.

The revised theorems are:

1. The change in slope between any two points is equal to the sum of the area of the unit rotation diagram and the angular yield of plastic hinges between the two points.
2. The deflection of one point on the elastic curve to a tangent to the curve at some other point is the static moment of the area of the unit rotation diagram and the first moment of the angular yield of plastic hinges between the two points, taken with respect to the point for which deflection is desired.
3. The slope at any point is the shear at that point of an imaginary end-supported beam loaded with the unit rotation diagram combined with the angular yield of plastic hinges as concentrated loads located at their respective points of development.

4. The deflection at any point is equal to the moment at that point of an imaginary end-supported beam loaded with the unit rotation diagram combined with the angular yields of plastic hinges as concentrated loads located at their respective points of development.

Considering a short section of beam, Fig. 16a, the rate of change of slope is

$$d\theta = \left( \frac{\epsilon_c + \epsilon_t}{d} \right) ds,$$

and therefore  $\phi = \frac{d\theta}{ds} = \frac{\epsilon_c + \epsilon_t}{d}$  (1)

For a concrete beam, that is under-reinforced, Fig. 16b, an expression for unit rotation is developed thusly:

From statics it is known that  $C = T$  and therefore,

$$p f_g = \frac{1}{2} k f_c = k f_{av}. \quad (2)$$

where  $p = A_g/bh$  and  $k = a/h$ . If a plane section remains plane after loading the following expression results:

$$\frac{\epsilon_c}{\epsilon_t} = \frac{k}{1 - k} \quad (3)$$

now by combining equation (2) and (3)

$$\epsilon_c + \epsilon_t = \frac{\epsilon_c f_{av}}{p f_g} \quad (4)$$

FIG. 16

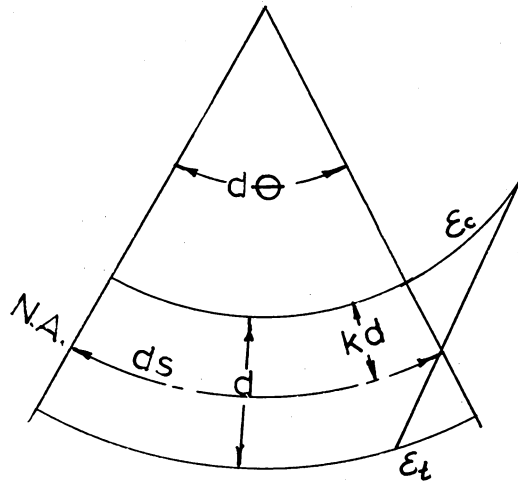

a. CURVATURE GEOMETRY

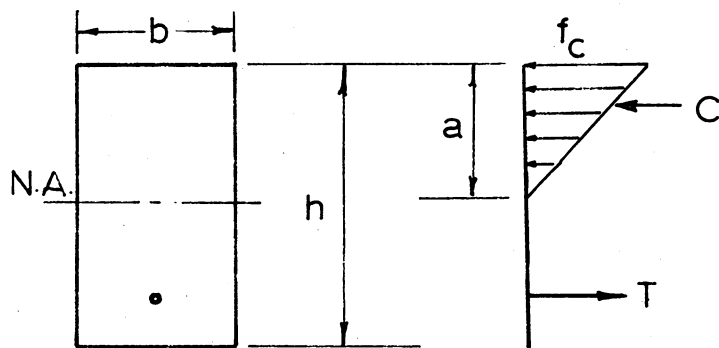

b. FORCE DIAGRAM

and since  $\phi d = \epsilon_c + \epsilon_t$ , the unit rotation at first crack and at ultimate load are:

$$\phi_c = \frac{\epsilon_c + \epsilon_t}{d}$$

and

$$\phi_u = \frac{\epsilon_c f'_c}{d p f_g}$$

By using the revised moment area theorems, deflection equations are developed for a simple supported beam, Fig. 17, loaded at third points.

The deflection at first crack is the moment of the left side of the conjugate beam about the center line:

$$\Delta_c = \frac{\phi_c L^2}{72} + \frac{5 \phi_c L^2}{108} - \frac{\phi_c L^2}{6}$$

or

$$\Delta_c = \frac{23}{216} \phi_c L^2$$

Likewise ultimate deflection is the moment of the right side of the conjugate beam about the center line.

$$\Delta_u = \frac{\phi_c L^2}{72} + \frac{5 \phi_c L^2}{108} + (\phi_u + \phi_c) \frac{L^2}{72} - (\phi_u + \phi_c) \frac{L^2}{12}$$

$$\Delta_u = \left( \frac{\phi_c}{27} + \frac{5 \phi_u}{72} \right) L^2$$

FIG.17

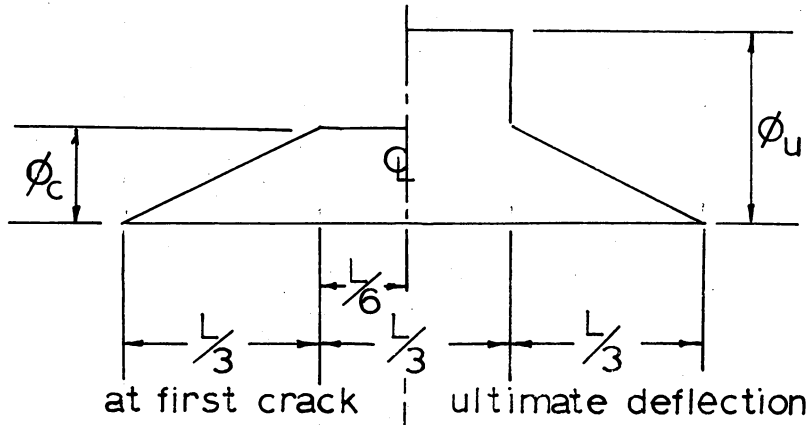

a. UNIT ROTATION DIAGRAM

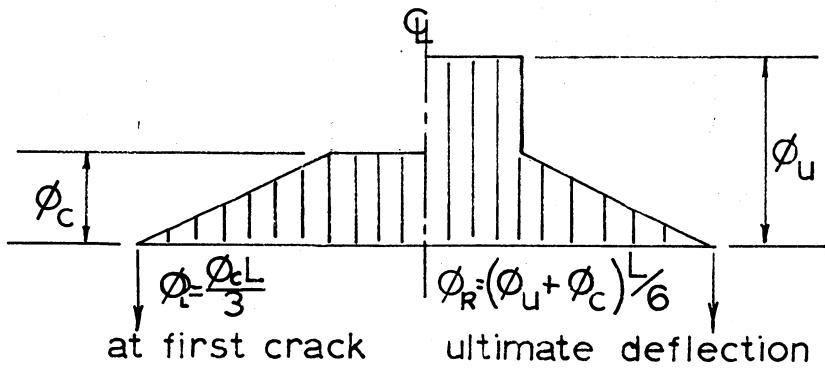

b. CONJUGATE BEAM

Test DataTest No. 1 - Investigation of Suitable Grip

Date: 4-9-62.

Type of Grip: Supreme Strand Chuck #780.

Specimen: Avg. dia. = 0.251 inches; length 18 inches.

Test Machine: Tinius Olsen - 60,000 lb. cap., #45659.

Specimen loaded at rate of 0.05 in./min. (strain). Load increased at steady rate until failure. Failure occurred at load of 3000 pounds. This corresponds to a unit stress of 63,200 psi computed over the gross area of the rod.

Failure occurred in top grip by cutting of the rod within the jaw assembly. Rod failed after being cut, by shattering along vertical planes. Examination of rod indicated an uneven bearing in the grip.

Note: Try placing protective cover between rod and grip.

Test No. 2 - Investigation of Suitable Grip

Date: 4-9-62.

Type of Grip: Supreme Strand Chuck #780.

Specimen: Avg. dia. = 0.251 inches; length 18 inches.

Test Machine: Tinius Olsen - 60,000 lb. cap., #45659.

Specimen coated with fine carborundum powder and a copper sleeve 1/32 inch thick was fitted over the end to protect glass rod from the jaw assembly. The copper sleeve was made from standard copper pipe, split and formed around end of rod.

Specimen was loaded at rate of strain of 0.05 in./min. until failure. Load increased at uniform rate to 3,755 pounds at which time failure occurred. This corresponds to a unit stress of 76,500 psi, figured over gross area of rod.

During initial stage of loading slippage occurred in the top grip. Test was stopped and the grip tightened. Before tightening, load was removed. After correction the test was continued.

Failure occurred due to crushing within grip. Examination of rod indicated uneven bearing as cause of failure.

Test No. 3 - Investigation of Suitable Grip

Date: 4-9-62.

Type of Grip: Reliable Strandvise #5102.

Specimen: Avg. dia. = 0.251 inches; length 12 inches.

Test Machine: Tinius Olsen - 60,000 lb. cap., #45659.

Specimen coated with fine carborundum powder and covered with a copper sleeve 1/16 inch thick. Copper sleeve was made from standard copper pipe, split and formed around end of rod.

Specimen was loaded at strain rate of 0.05 in./min. Slippage occurred in bottom grip at a load of 75 pounds. This could not be corrected during test.

Rod was examined and no apparent damage had occurred.

Note: Since slippage has occurred in previous tests using sleeve, try softer copper or lead. This may cause plastic flow of the sleeve with less load, and gripping action may take place sooner.

May also try revising jaw assembly of grips to eliminate crushing.

Test No. 4 - Investigation of Suitable Grip

Date: 4-13-62.

Type of Grip: Supreme Strand Chuck #780 (revised).

Specimen: Avg. dia. = 0.251 inches; length 9 inches.

Test Machine: Tinius Olsen = 60,000 lb. cap., #45659.

For this test the conical jaws were revised as shown in Fig. 5. The lower portion of each section was removed for a distance of one-half inch so that bearing would take place in the upper half of the grip. The teeth on the inner surface were also removed.

The ends of the rod were coated with carborundum powder. This was done by first applying a thin coat of duco cement and rolling the rod over a sheet of glass on which the powder had been spread. The rod also had a copper sleeve 1/32 inch thick placed over the ends.

Specimen was loaded at strain rate of 0.05 in./min. until failure. Failure occurred at load of 4,750 pounds. This corresponds to a unit stress of 97,000 psi computed over gross area.

Failure was caused by misalignment of grips. Examination of rod showed that bearing within the grip was much improved; however, some local crushing did occur before failure.

Test No. 5 - Preliminary Study of Stress Strain  
Characteristics of Fiber Glass Rod

Date: 4-20-62.

Type of Grip: As noted.

Specimen: Avg. dia. = 0.251 inches; length 15 inches.

Test Machine: Tinius Olsen - 60,000 lb. cap., #45659.

This test is to provide preliminary data of the stress strain properties of the fiber glass rods used in the tests and at the same time investigate several types of end grips.

Four types of grip were employed. These are as follows:

1. Supreme Strand chuck #780 (Revised) with lead sleeve.
2. Supreme Strand chuck #780 (Revised) no sleeve.
3. Strandwise 5102 with lead sleeve.
4. Crimped copper pipe.

Specimens were loaded at strain rate of 0.05 in./min. until failure. Stress strain data were recorded using mechanical recording device coupled with the testing machine.

All of the specimens tested showed a characteristic straight line stress strain relationship throughout the range of load applied. Several specimens were subjected to three or more load cycles and each indicated perfect elastic properties.

## Test No. 5 - (Cont'd)

## Data

Grip	Ultimate Load (lb.)	Stress (psi)	Strain (in./in.)	Modulus of Elasticity (psi)
1	1500	30380	--	--
2	2700	55700	0.0826	$6.74 \times 10^6$
3	1100	22300	0.0346	$6.45 \times 10^6$
4	1500	30380	0.0445	$6.8 \times 10^6$

Test No. 6 - Investigation of Suitable Grip

Date: 4-14-62.

Type of Grip: Tapered Dowel.

Specimen: Avg. dia. = 0.251 inches; length 12 inches.

Test Machine: Tinius Olsen - 60,000 lb. cap., #45659.

End grips were made using 7/8 inch diameter steel dowel. The dowel was drilled through center with a drill slightly larger than 1/4 inch for a snug fit around glass rod. One end was then tapered as shown in Fig. 4.

The grips were placed in a clamp with the fiber glass rod inserted into the end as shown in Fig. 1. The rod was then split into quarters using a knife blade and the sections wedged apart using small sections of metal. The fiber glass was then bonded to the grip with an epoxy adhesive\* and allowed to cure for 33 hours at room temperature.

Specimen was placed in testing machine and loaded at a strain rate of 0.05 inches per minute. Load and strain increased according to a straight line until at a load of 1500 pounds, then some deviation was noted. Slippage occurred in the top grip at 3450 pounds. Loading was continued but load dropped off. Slippage in bottom grip noted at 2000 pounds. Load continued until failure at 5125 pounds. This corresponds to stress of 104,600 psi computed on gross area of the rod.

The large strain observed during first of test is attributed to low modulus of epoxy or possibly the grip not being filled completely thus allowing slippage.

---

\* Hysol Epoxi-Patch Kit produced by Hysol Corp., Olean, N.Y.

Test No. 7 - Investigation of Suitable Grip

Date: 4-18-62.

Type of Grip: Tapered Dowel.

Specimen: Avg. dia. = 0.251 inches; length 12 inches.

Test Machine: Tinius Olsen - 60,000 lb. cap., #45659.

Specimen prepared as in Test No. 6, however, the ends of the rod which had been split were wedged apart with short pieces of wire. The wire was cut so that the rod would be forced against the sides of the steel grip.

The specimen was loaded at the standard rate of strain of 0.05 in./min. Slight slippage occurred at load of 5250 pounds but load was continued since there was no apparent damage to rod.

Failure of specimen occurred at load of 6550 pounds which corresponds to approximately 133,900 psi computed over the gross area of the rod.

Examination of the failure indicated diagonal shear failure occurred at the point of intersection of the taper and the drilled hole.

It is proposed to change the grip used by eliminating the sharp breaking point believed to have caused the failure.

Test No. 8 - Investigation of Suitable Grip

Date: 5-2-62.

Type of Grip: Tapered Dowel.

Specimen: Avg. dia. = 0.251 inches; length 12 inches.

Test Machine: Tinius Olsen - 60,000 lb. cap., #45659.

The grip used for this test was the same as that used for Test No. 7, but the inside taper was revised to eliminate the sharp transition from center hole to taper.

The specimen was prepared in the same manner as those for Tests No. 6 and No. 7. A post yield strain gage, type PA-3, was placed on the fiber glass rod for recording strain data.

Specimen loaded at standard rate of strain of 0.05 in./min. Slippage noted at load of 5525 pounds. After slippage the load fell off and then recovered until failure at load of 5475 pounds.

The results of this test indicate ultimate short time strength of 113,000 psi computed over gross area. Ultimate strain at failure was 0.016 inches per inch. The elastic modulus calculated from data was  $7.1 \times 10^6$  psi. Fig. 10 shows stress strain curve.

It appears that this grip will give good service up to 100,000 psi or better.

Test No. 2 - Investigation of Ultimate Strength  
and Stress Strain Characteristics

Date: 5-2-62.

Type of Grip: Supreme Strand Chuck.

Specimen: Avg. dia. 0.251 inches; length 15 inches.

Test Machine: Tinius Olsen - 60,000 lb. cap., #45659.

The specimen for this test was prepared according to Federal Test Method Standard No. 406, Method 1011, with the exception that the temperature and humidity were not controlled.

To prepare the specimen it was placed in a metal lathe and turned down to 60 per cent of its original diameter.

Strain was measured using a post yield strain gage, PA-3, fastened to the necked down portion of the specimen.

Specimen loaded at standard rate of strain, 0.05 in./min.

Stress strain curve is shown in Fig. 18.

FIG. 18  
STRESS STRAIN CURVE  
TEST NO. 9

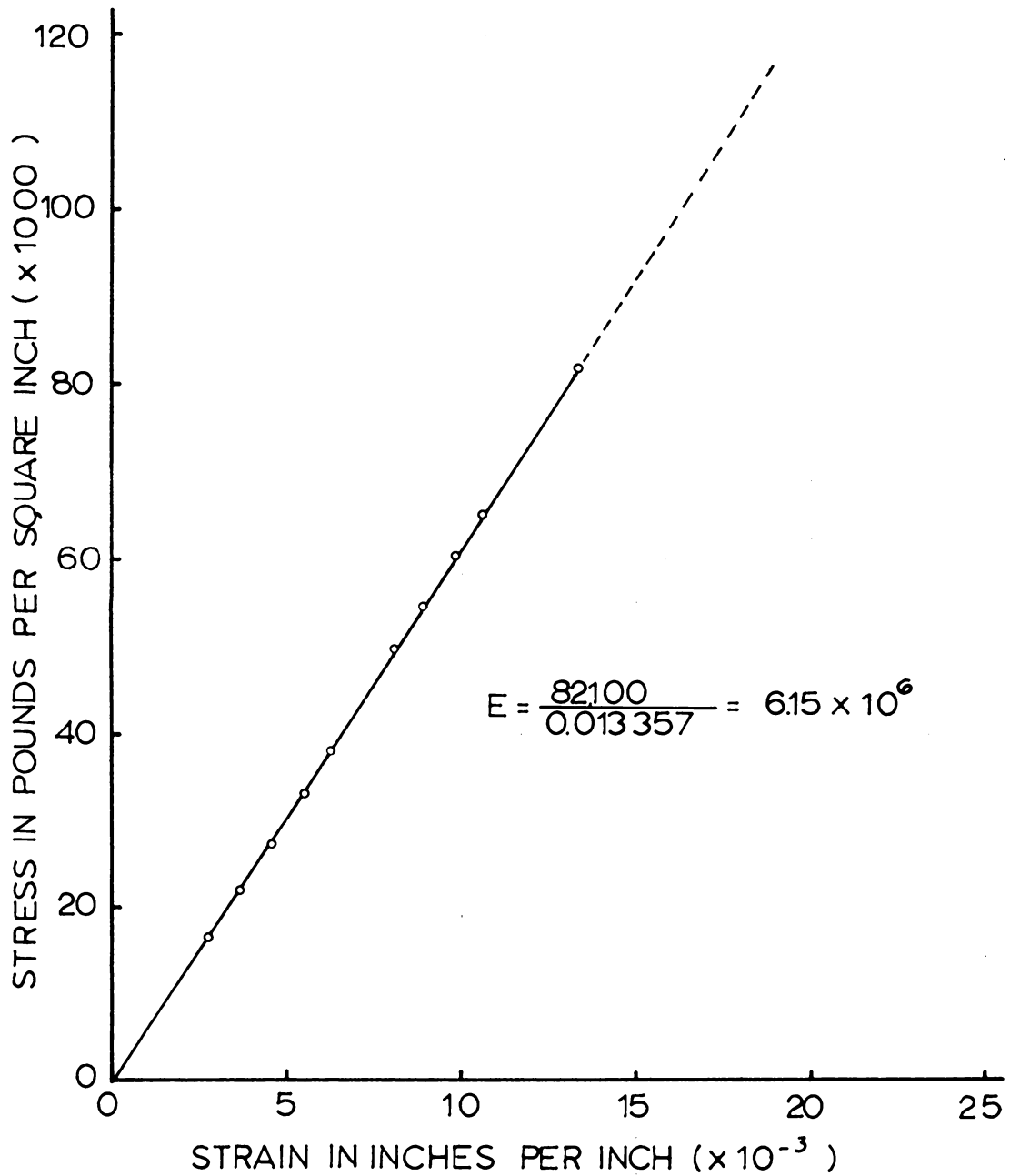

Test No. 10 - Calibration of Load Cell

Date: 5-15-62.

Test Machine: Tinius Olsen - 60,000 lb. cap., #45659.

The load cell to be used in measuring the post-tension force within the fiber glass did not have a name plate with data. Therefore, before loads could be determined the load coefficient had to be determined for the load cell.

The load coefficient was determined in the following manner. After placing the load cell in the testing machine and connecting the proper electrical strain recorder, the load cell was subjected to three repetitions of load. During the load cycles, readings of strain and load were recorded at 1000 pound intervals. Using the recorded data a calibration curve was drawn, Fig. 19, so that loads could be determined from strain readings. The load coefficient,  $k$ , is the load divided by the strain. Therefore loads above those on the curve can be calculated by multiplying strain by the load coefficient.

$$k = \frac{\text{load}}{\text{strain}} = 2.5 \times 10^6$$

FIG. 19  
LOAD CELL  
CALIBRATION CURVE  
TEST NO. 10

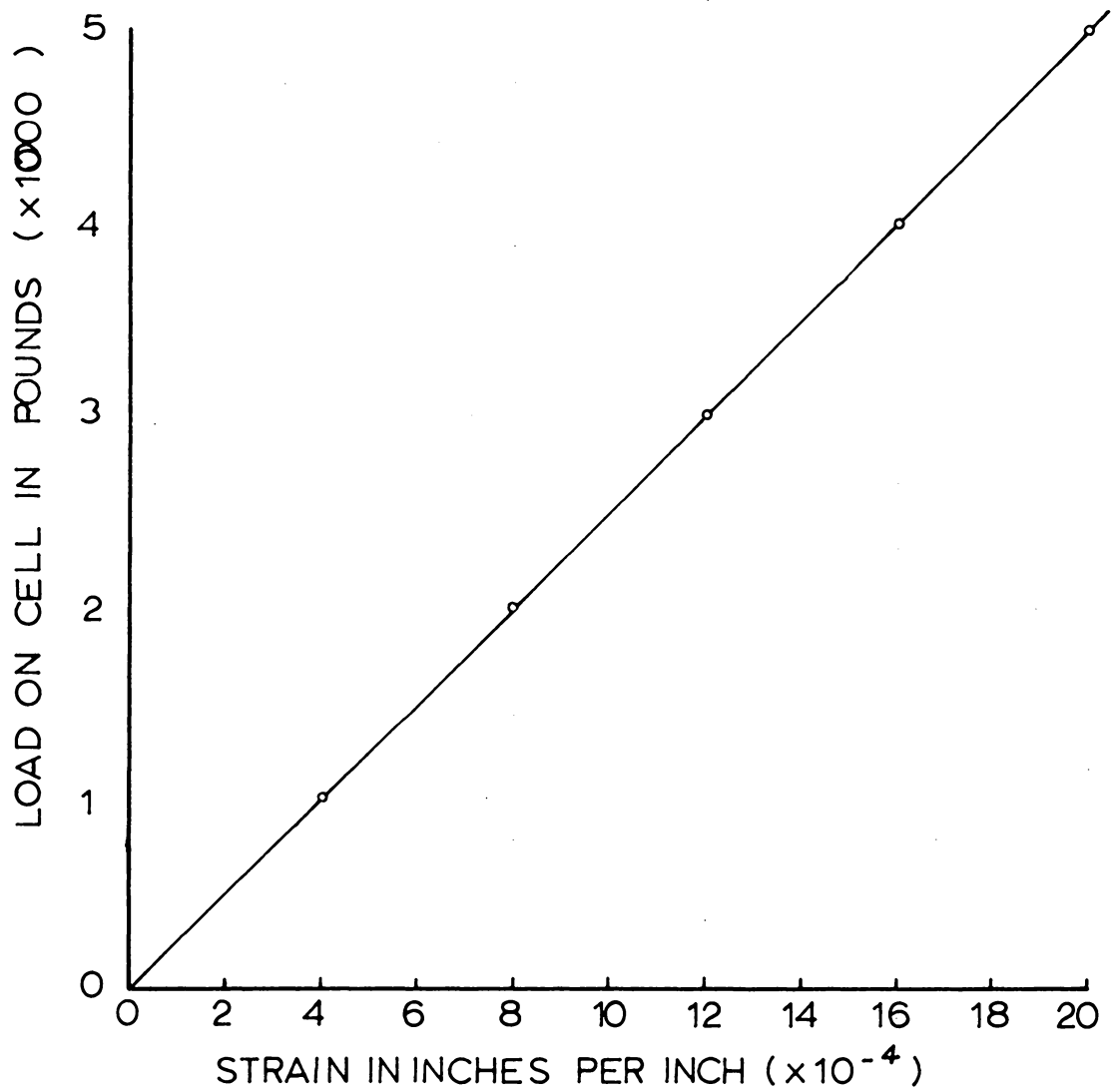

Test No. 12 - Investigation of Suitable Grip

Date: 6-4-62.

Type of Grip: Reliable Squeeze Sleeve.

Specimen: Avg. dia. = 0.250 inches; length 15 inches.

Test Machine: Tinius Olsen - 60,000 lb. cap., #45659.

The sleeve was placed over the end of the specimen and epoxy hysol cement was used to bond the fiber glass to the metal.

Specimen loaded at standard strain rate of 0.05 in./min. until failure. Failure occurred at a load of 5580 pounds, corresponding to a stress of 116,000 psi. The failure occurred within the grip by the rod slipping out of the sleeve.

Slippage resulted from loss of bond between epoxy and fiber glass. Before failure occurred yielding was observed in the specimen. Since there were no indications of yield within the fiber glass it is assumed that this occurred within the grip.

Test No. 13 - Investigation of Suitable Grip

Date: 6-4-62.

Type of Grip: Tapered Dowel, with Marson's epoxy.

Specimen: Avg. dia. = 0.25 inches; length 15 inches.

Test Machine: Tinius Olsen - 60,000 lb. cap., #45659.

The grip in this test is the same as used in Test No. 8, with the exception of the resin. The resin was Marson's G-15 epoxy resin produced by Marson Corporation, Revere, Mass. The epoxy was mixed four parts resin to one part hardener.

When mixing the epoxy too much hardener was used and the mix did not harden properly. The specimen was cured for seven days at room temperature and atmospheric pressure. At the time of testing the epoxy was still not hard.

Specimen loaded at standard rate of strain of 0.05 in./min. No slip observed until failure which occurred at a load of 5420 pounds. This corresponds to a stress of 110,800 psi computed over gross area of the rod.

Test No. 14 - Investigation of Ultimate Strength  
and Stress Strain Characteristics

Date: 6-7-62.

Type of Grip: Tapered Dowel.

Specimen: Avg. dia. = 0.259 inches; length 18 inches.

Test Machine: Tinius Olsen - 60,000 lb. cap., #45659.

Specimen prepared as in Test No. 13 and a post yield strain gage, PA-3, was used to record strain data.

Specimen loaded at standard rate of 0.05 in./min. until failure. Failure occurred at a load of 8625 pounds or a stress of 164,000 psi figured on gross area of the rod.

Strain readings were recorded until a load of 5650 pounds at which time the meter ran off the scale. The data recorded to this point indicate, Fig. 20, elastic stress strain relationship and an elastic modulus of  $6.42 \times 10^6$  psi.

FIG. 20  
STRESS STRAIN CURVE  
TEST NO. 14

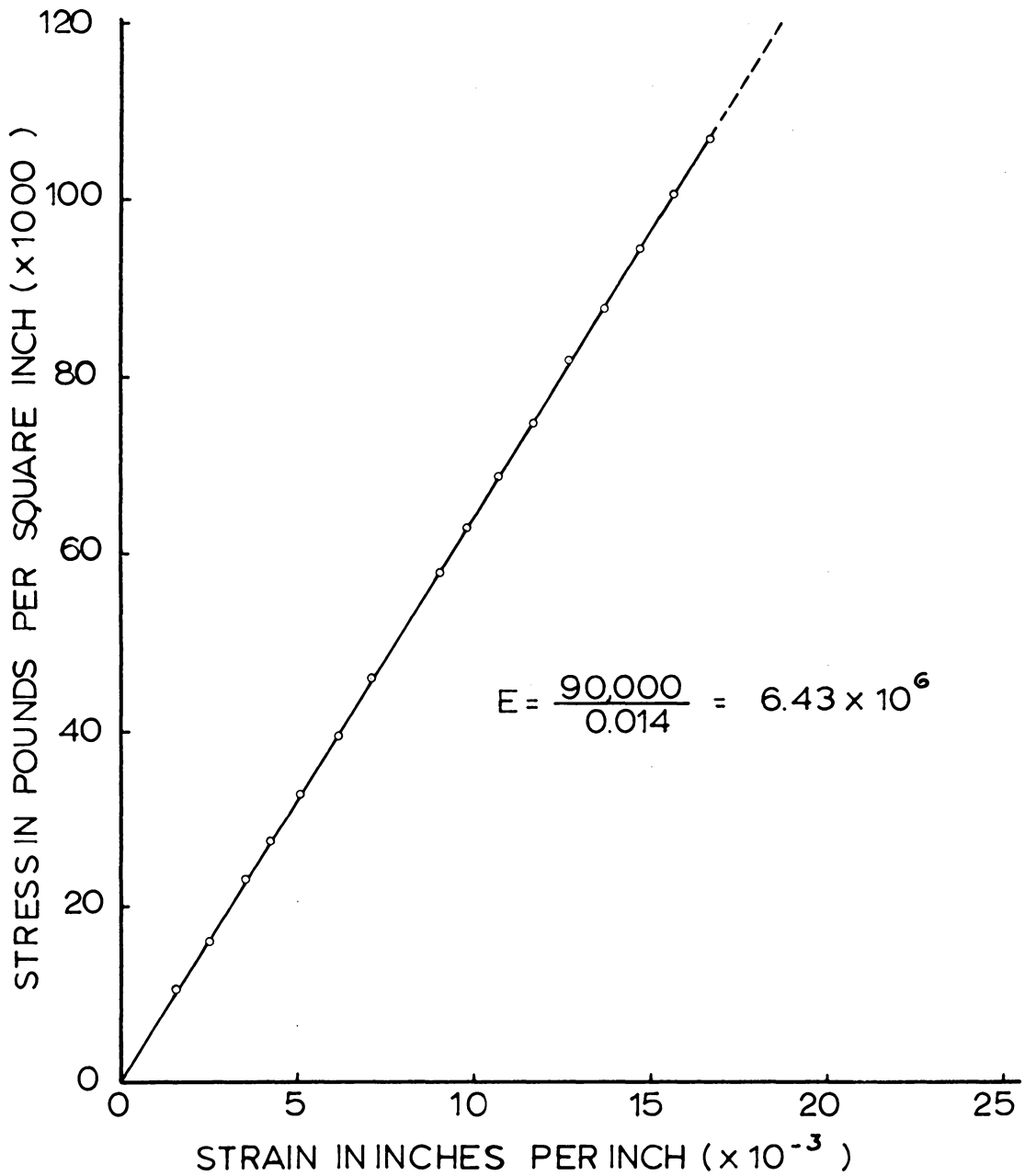

Test No. 15 - Investigation of Ultimate Strength  
and Stress Strain Characteristics

Date: Not recorded.

Type of Grip: Tapered Dowel with Marson's epoxy.

Specimen: Avg. dia. = 0.258 inches; length 18 inches.

Test Machine: Tinius Olsen - 60,000 lb. cap., #45659.

This specimen was taken from a section of the rod used in tensioning beam number two. The end grips were prepared as in Test No. 14.

In order that the strain readings could be recorded over a wider range a variable resistor was placed in the circuit.

Data recorded show that the specimen had an ultimate strength of 9400 pounds or 180,000 psi and an elastic modulus of  $7.1 \times 10^6$  computed over the straight portion of the curve, Fig. 21.

Failure in this test occurred in the rod itself. The failure was very sudden, much like an explosion, with glass and plastic dust filling the air.

The slight deviation from the straight line relation of stress strain noted on the curve may be due to yielding in the epoxy bonding material within the grip.

FIG. 21  
STRESS STRAIN CURVE  
TEST NO. 15

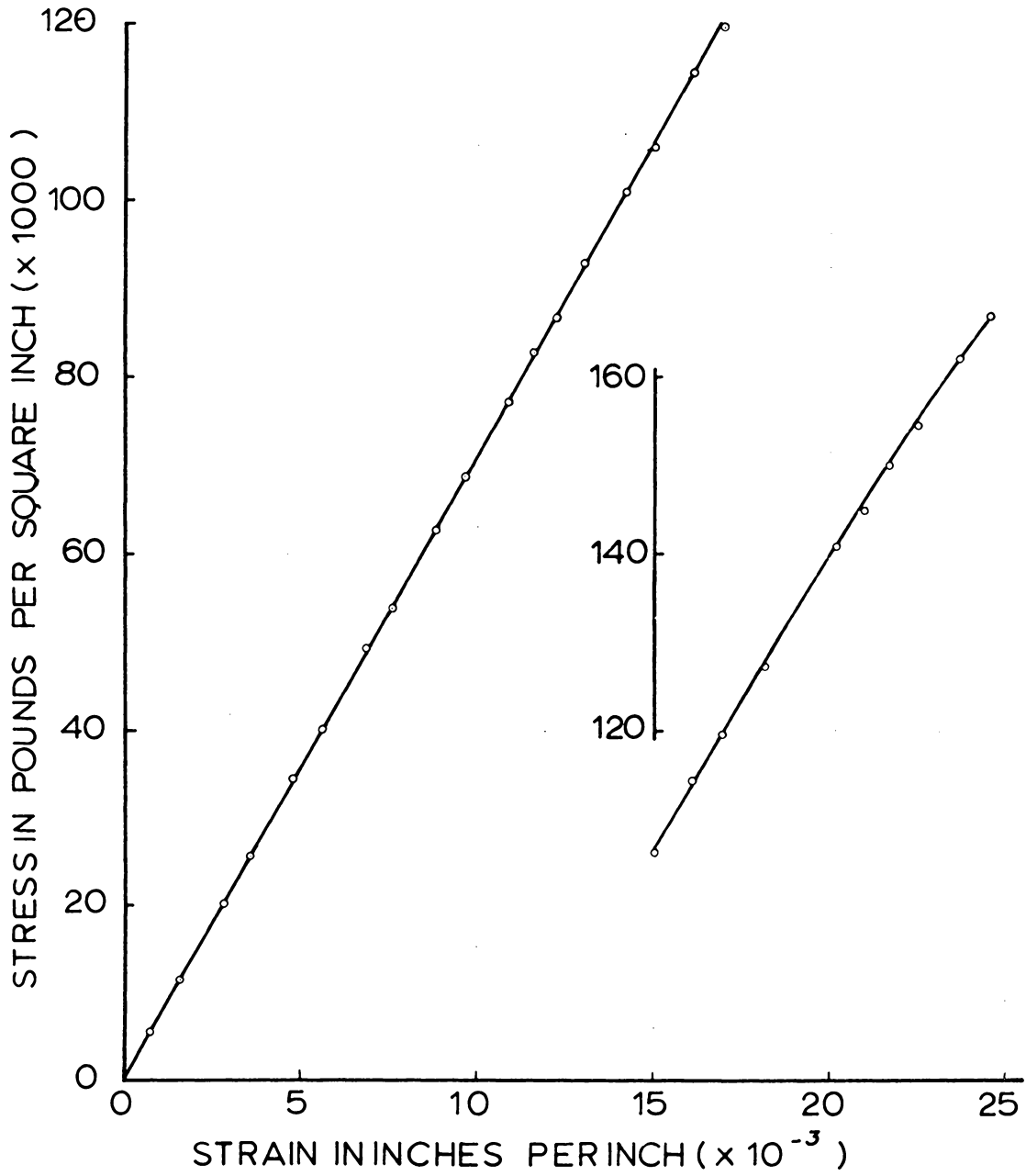

Test No. 16 - Investigation of Ultimate Strength  
and Stress Strain Characteristics

Date: 6-14-62.

Type of Grip: Reliable Squeeze Sleeve bonded with Marson's epoxy.

Specimen: Avg. dia. = 0.257 inches; length 18 inches.

Test Machine: Tinius Olsen - 60,000 lb. cap., #45659.

The specimen was prepared by placing Reliable Squeeze Sleeves on the end of the fiber glass rod and filling the void with Marson's G-15 epoxy. The grips were cured as in Test No. 14.

In order that strain readings could be recorded a PA-3 post yield strain gage was fastened to the specimen.

The specimen was loaded at a rate of strain of 0.05 in./min. Failure occurred at a load of 5425 pounds and was due to slippage within the grip.

Data was recorded and a stress strain curve, Fig. 22, drawn for the fiber glass rod.

FIG. 22  
STRESS STRAIN CURVE  
TEST NO.16

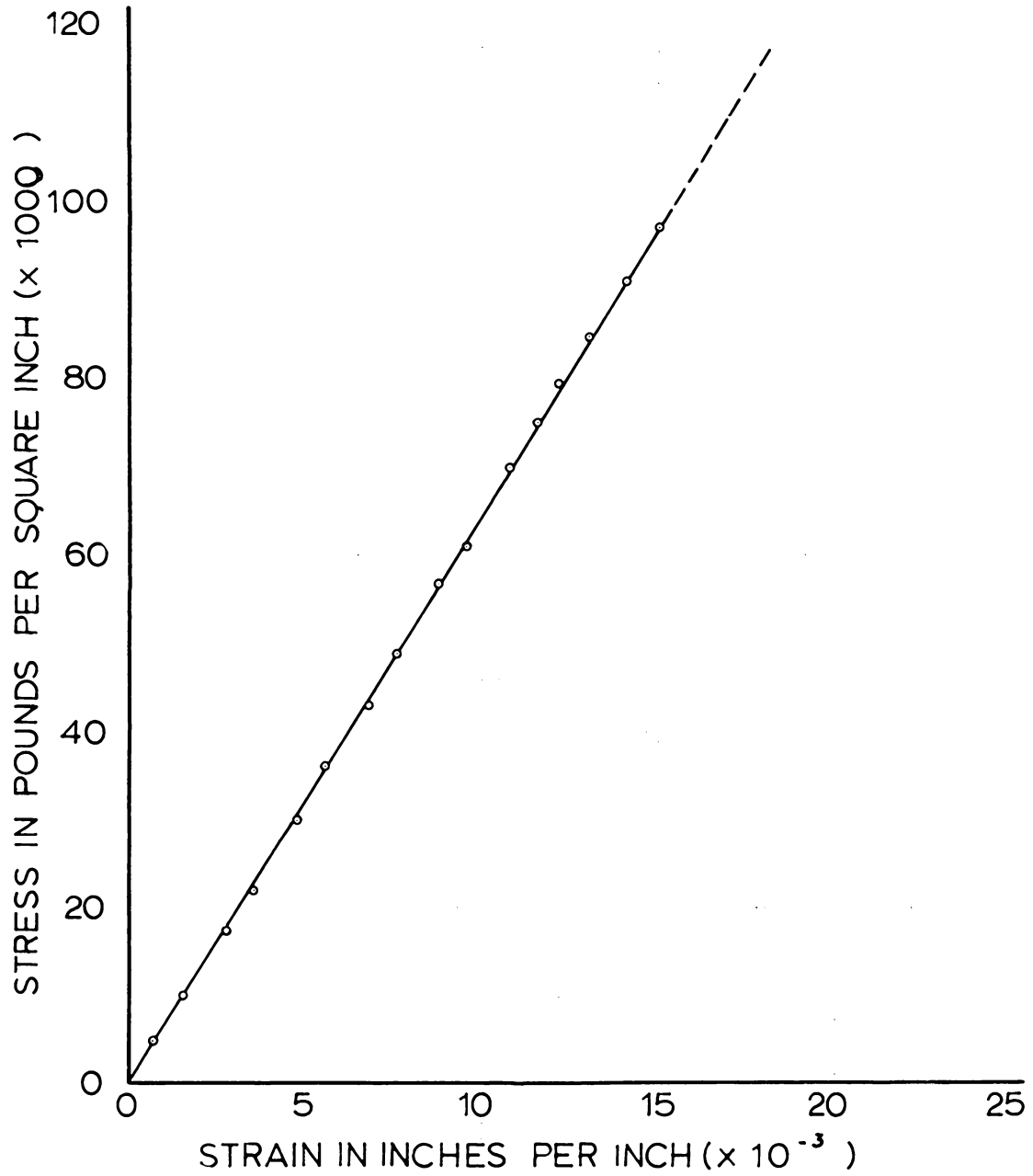

Test No. 17 - Investigation of Suitable Grip

Date: 9-22-62.

Type of Grip: Fanngrasp.

Specimen: Avg. dia. = 0.258 inches; length 4.0 feet.

Test Machine: Tinius Olsen - 60,000 lb. cap., #45659.

The specimen was prepared by wrapping the ends of the Fanngrasp about the fiber glass rod. To wrap the rod the ends of the grip are pulled away from the fiber glass and wrapped with a clockwise motion. Since the inside of the grip is coated with an abrasive, care must be taken not to damage the fiber glass.

The specimen was placed in the testing machine and loaded at a rate of strain of 0.05 in./min. until failure. Failure occurred at a load of 6440 pounds. This corresponds to a stress of 123,500 psi, computed over the gross area of the fiber glass.

Investigation of specimen after failure indicated possible damage to fiber glass while placing grip on rod.

Beam tests

-- general --

Three precast beams were made for performing flexural tests. After the concrete had cured the fiber glass prestressing rod was inserted into the member through a preformed duct. Special designed grips were then fastened to the fiber glass before the stressing operation, Fig. 23.

To measure the tensile stress in the fiber glass rod two methods were employed. A post yield strain gage PA-3 was fastened to the rod before placing in the member for recording stress changes. Also a load cell, Fig. 24, was fastened to one of the end grips in such a way that tensile forces could be measured. The load cell was used as a check against the strain gage and to provide measurements in case of failure of the gage.

Strain measurements within the concrete were made using A-9 strain gages fastened to the top and bottom flange at the mid point of the beam.

During testing readings were taken simultaneously of total load, deflection, concrete strain, and fiber glass strain.

The beams were post-tensioned in the concrete laboratory and then carried to the materials testing laboratory, in an adjoining room, for testing.

FIG. 23  
DETAIL OF TENSIONING DEVICE

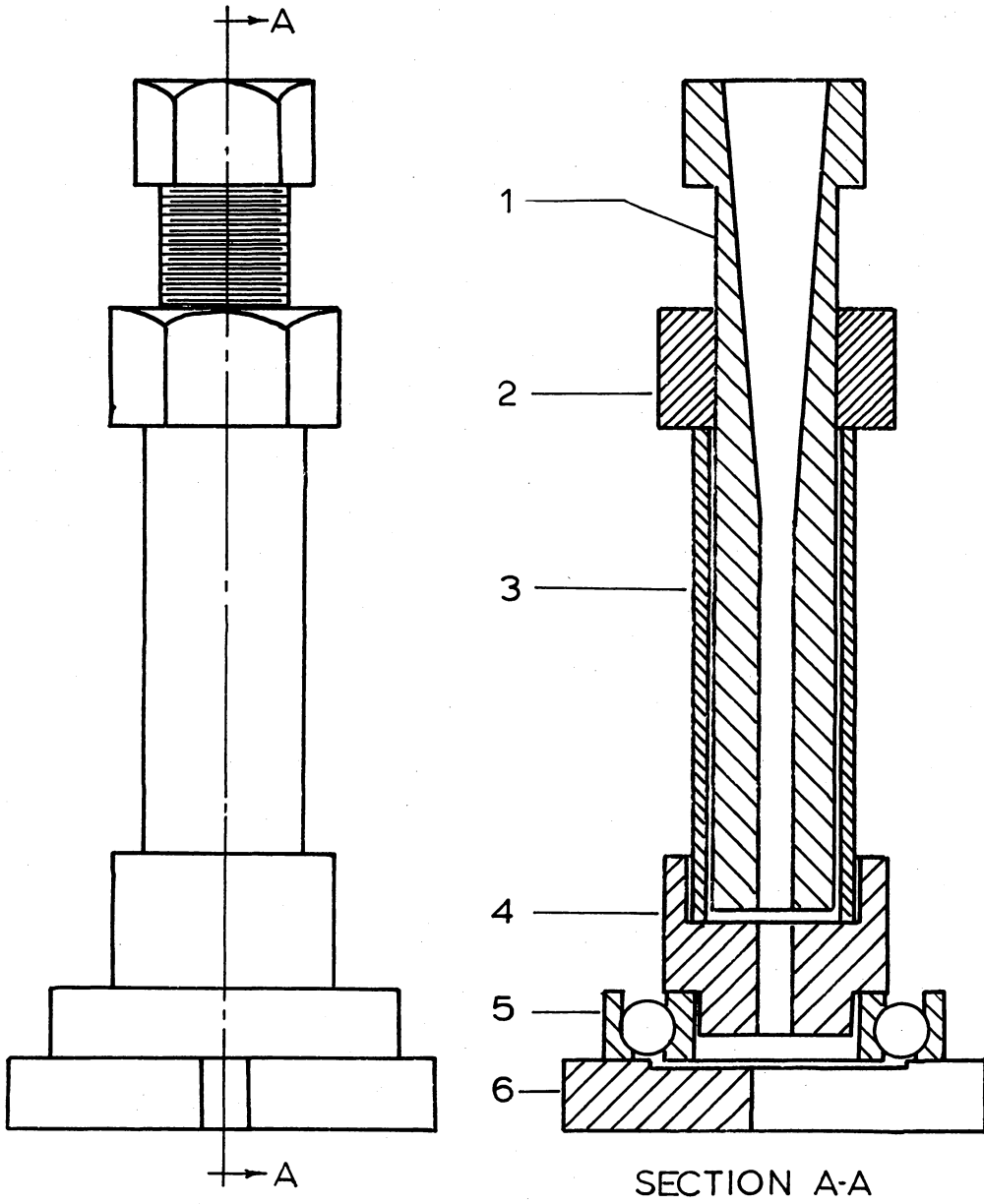

Scale:  $\frac{3}{4}'' = 1''$

- |                      |                  |
|----------------------|------------------|
| 1 End Grip           | 4 Adapter        |
| 2 Tensioning Nut     | 5 Thrust Bearing |
| 3 Compression Collar | 6 Bearing Plate  |

FIG. 24  
TENSION INDICATOR

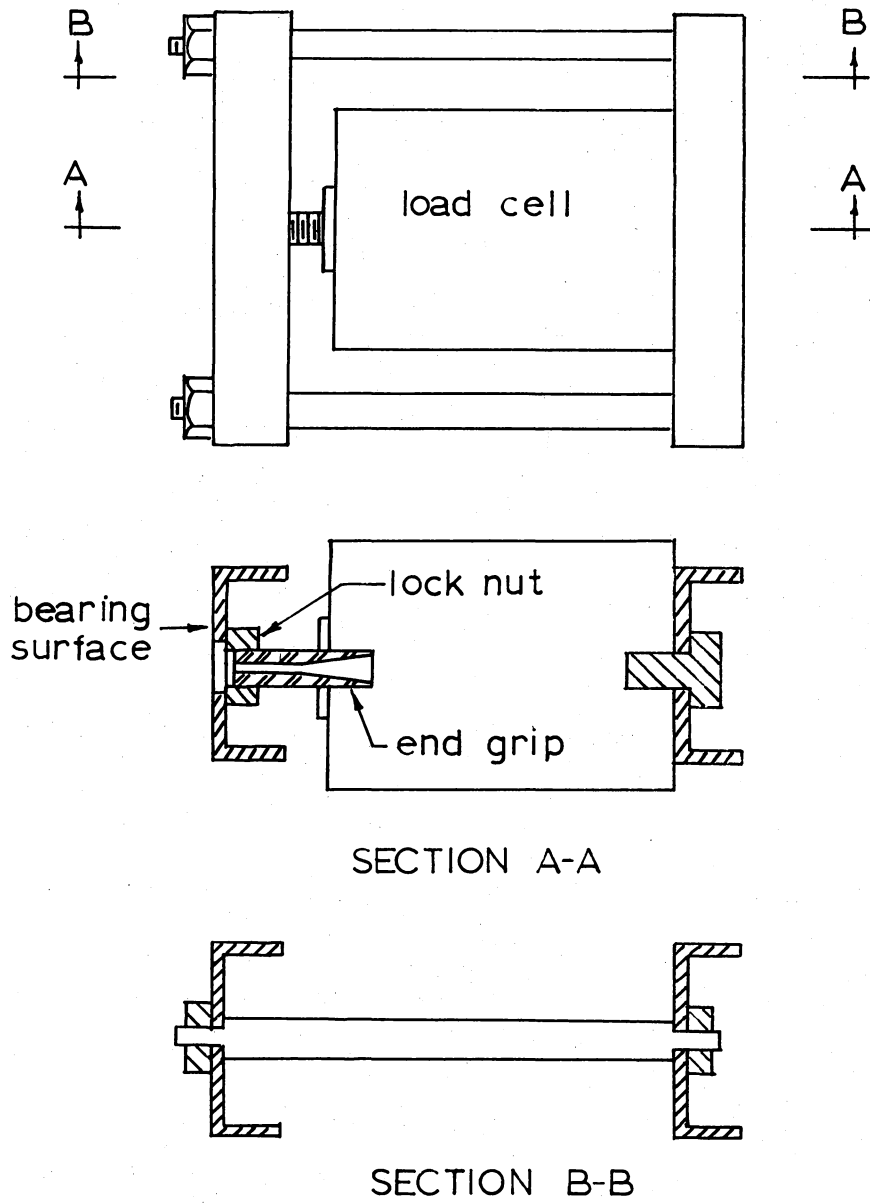

Concrete test cylinders and flexural specimens were made for each member tested. These tests were made at the same time as the beam test to obtain actual compressive and flexural strengths. Table III shows the value of the compressive strength  $f'_c$  and flexural strength  $f'_t$  for each of the specimens.

-- beam no. 1 --

The beam used in this test was broken in half during the post-tensioning operation. The end grip fastened to the load cell slipped releasing the 3000 pound compressive force exerted by the fiber glass. This release of energy split the concrete beam.

The epoxy resin being used for bond when the beam broke was Hysol Epoxi-Patch Kit. This was replaced with Marson's G-15 epoxy resin. Marson's epoxy resin appears to have superior qualities over the Hysol.

After replacing the end grips the member was again post-tensioned. Due to the crack only 4570 pounds of tensile force was applied to the fiber glass.

Since the member was cracked no strain gages were placed on the concrete, but a post yield gage PA-3 was placed on the fiber glass rod and a load cell was fastened to one grip to measure the prestressing force.

During the test readings were taken of total load, deflection and fiber glass stress.

Table IV shows the tabulated test data.

Table III

Compressive and Flexural Strength of Concrete  
at Time of Testing Beams

Specimen* No.	Taken From Beam No.	$f'_c$ (psi)	$f'_m$ (psi)
1	1	687.8	
2	1		5,060
3	2	633.4	
4	2		4,575
5	3	684.3	
6	3	674.0	
7	3		4,040
8	3		4,325

\* All compressive test cylinders were made according to procedure stated in ASTM C31-44 with the exception of curing. Specimens were cured at atmospheric conditions as were the precast beams.

Flexure test specimens were taken from the end of the precast members used for beam tests.

Table IV

## Test Data Beam No. 1

Load (lb.)	Deflection (in.)	Post-tension Force (lb.)	Remarks
35	0.000	4570	Begin test
200	0.002		
400	0.006		(Note $A_g = 0.0510$
600	0.011		$E_g = 6.757 \times 10^6$
800	0.014		= avg. value)
1000	0.018	4570	
1200	0.024		
1400	0.028		
1600	0.033		
1800	0.038	4600	
2000	0.045	4600	Visible crack in bt. flange
2200	0.051	4610	
2400	0.058	4630	
2600	0.069	4640	
2800	0.087	4700	Yielding
3000	0.126	--	"
3200	0.168	4750	"
3300	0.245	4850	"
3400	0.327	4990	"
3500	0.445	5150	"
3600	0.539	5270	"
3710	0.671	5460	"
3800	0.774	5600	"
3750	0.995	5750	"
3960	1.228	6000	Failure - compression failure in top flange of member.

-- beam no. 2 --

This beam was tested in flexure having load applied at the third points. The recorded test data included total load, deflection, fiber glass strain, concrete strain and tension on load cell.

The beam was post-tensioned with a tensile force of 5,620 pounds which for the rod diameter of 0.259 inches corresponds to a stress of 107,000 pounds per square inch. Load was applied until the top flange began to fail in compression. The load was then removed and readings were taken during recovery.

Table V lists the tabulated data and calculated concrete stresses in the top and bottom flange. The post-tension force was determined by the use of a PA-3 strain gage fastened to the fiber glass rod. Concrete strain was measured with A-9 strain gages fastened at the center line of the flange. An ames dial was placed at the mid point of the beam for recording deflection.

The beam was loaded at a uniform rate with data recorded at each 200 pound increment of load. Loading was continued until compression in the top flange caused spauling. The load was removed and a final deflection reading was taken.

Table V

Test Data Beam No. 2

Total Load (lb.)	Post-tension		Def. (in. x 10 <sup>-3</sup> )	Concrete Strain		Calculated f <sub>c</sub>		Remarks
	Gage (lb.)	Cell (lb.)		Top (psi)	Bottom (psi)	Bottom (psi)	Top (psi)	
0	5620	5500	0.0	100	-220	-1199	+331	
300			5	80	-190			
400			6.5	75	-180			
600			9.8	50	-165			
800			12.5	40	-140			
1000	5644	5500	15.5	15	-130	-652	-205	
1200		5520	18.9	0	-110			
1400			22.0	-20	-90			
1600			24.9	-35	-80			
1800			28.9	-60	-55			
2000			31.5	-75	-40			
2200	5660		34.9	-100	-20	+3.3	-848	
2400			37.0	-120	-5			
2600			40.1	-135	+20			
2800			43.9	-155	35			
3000			47.0	-175	60			
3200			50.1	-190	70			
3400			54.8	-220	100			Crack heard
3600	5681	5520	60.0	-235	115	+771.2	-1599	Crack visible
3570	5790	5570	119.0	--	--			@ 1/3 pt.
3700	5840	5600	159.0					yielding
3800	5890	5600	174.0					1/16" crack
3900	5910	5610	199.0					
3950	6040	5650	280.0					
4000	6090	5675	307.0					1/8" crack
4050	6200	5720	376.0					
4100	6280	5800	451.0					1/4" crack
4110	6510	5925	625.0					
0	--	--	63.0					Permanent deflection

-- beam no. 3 --

This beam was post-tensioned with a force of 5585 pounds and tested in the same manner as beam no. 2. Table VI shows the tabulated test data.

Table VI

Test Data Beam No. 3

Total Load (lb.)	Post-tension Force (lb.)	Def. (in.)	Concrete Strain		Calculated $f_c$		Remarks
			Top (psi)	Bottom (psi)	Top (psi)	Bottom (psi)	
0	5585	0.0	+333	-1205	90	-325	
400		0.006			45	-280	
600		0.012			5	-230	
800		0.012			5	-220	
1000	5598	0.015	-203	-659	-20	-205	
1200		0.019			-45	-175	
1400		0.022			-60	-155	
1600		0.026			-85	-125	
1800	5612	0.030	-632	-222	-105	-110	
2000		0.038			-130	-80	
2200		0.036			-150	-50	
2400		0.040			-170	-30	
2600	5625	0.044	-1061	+215	-200	0	
2800		0.048			-220	+25	
3000		0.052			-240	50	
3200		0.055			-265	75	
3400	5638	0.060	-1490	+652	-285	100	Crack 1/3 pt. yielding
3380	5742	1.102					
3500	5794	0.205					
3600	--	0.306					
3700	5899	0.412					
3800	6003	0.519					
3850	6107	0.624					
3900	6160	0.728					
3950	6264	0.833					
4000	6316	0.938					
4050	6395	1.040					
3920	6447	1.250					Failure

## VII. BIBLIOGRAPHY

1. U.S. Army Engineer Waterways Experiment Station, C.E., manuscript of Plastic-Glass Fiber Reinforcement for Reinforced and Prestressed Concrete, Summary of Information Available as of July 1955. Technical Memorandum No. 6-421, Report No. 1, Vicksburg, Miss., Nov. 1955.
2. Engineering (London). 1940 "Glass reinforcement for concrete." 150 No. 3897 September 20, 225.
3. \_\_\_\_\_ 1940, "Glass reinforcement for concrete." 150, No. 3897 October 4, 264-265.
4. Ivan A. Rubinsky, 1951. "Glass fiber being studied." Engineering News Record 147 No. 4, July 26, 47.
5. Ivan A. Rubinsky and Andrew Rubinsky. 1954. "A preliminary investigation of the use of fibre-glass for prestressed concrete." Magazine of Concrete Research 6 No. 17, September 71-73.
6. Editorial notes. "A word is wanted: a competition." Concrete and Constructional Engineering (Including Prestressed Concrete) Vol. 54, No. 9 (London September 1959), p. 292.
7. H. Craemer. 1930. "Monolithic glass and reinforced concrete construction." Beton u. Eisen 29:6, 109-113 (Zement 19 1930 pp. 1185-1188); ibid ref. No. 1, p.1.
8. A. L. Goldstein-Bolocan. 1938. "Perfection of the production of reinforced glass concrete with optimum water content." Cemento Armato Ind. Cemento, Vol. 35, 8-11, 29-34, 52-56 (C.Z.II, 1938, 920); ibid ref. No. 1 p.64.
9. Ray B. Crepps, 1951. "Glass fiber as tensioning element in prestressed concrete." Proceedings First U.S. Conference on Prestressed Concrete, Mass. Inst. Tech. August. 228-830.
10. Kenneth W. Keane, 1952. Investigation of the feasibility of using fiber glass for prestressing concrete. Masters Thesis, Princeton University, Princeton, New Jersey, pp. 62.

11. Norman J. Sollenberger, 1953. Glass fibers for tension materials. Paper presented April 30, at eighth session of conference on prestressed concrete, Newark College of Engineering, Newark, N.J.; Ibid ref. No. 1 p. 45.
12. John M. Weis, 1954. An investigation of the effect of repetitive loading on fiber glass rods in prestressed concrete construction. Master's thesis. Princeton University, Princeton, N. J., 112 pp.
13. Frank J. Maguire III, 1960. Report on Further Investigation Concerning the Feasibility of the Use of Fiber Glass Tendons in Prestressed Concrete Construction, Princeton University, Princeton, N.J.
14. K. L. Biryukovich et al Yu L. Biryukovich, 1957. "Concrete with Fibre Glass Reinforcement," Straitelnaya Promyshlennost, Vol.6, p.23-27; Translation C.T.S. 542.
15. Dr. Ing Stanislaw Kajfasz, 1960. "Some tests on beams prestressed by fibre glass cords." Magazine of Concrete Research Vol. 12 n. 35 July pp. 91-98.
16. N. M. Cameron. An Introduction to the Factors Influencing the Strength of Glass Fibres, T.&AM Report No. 186, Department of Theoretical and Applied Mechanics, University of Illinois, March 1961.
17. Trewhella, S.; Personal Communication, March 27, 1962, Columbia Products, Columbia, S.C.
18. Battelle Memorial Institute. High Temperature Creep Rupture Properties of Glass-Fabric-Plastic Laminates, NADC Technical Report 53-491, 1953.
19. Goldfein, Solomon. "Time Temperature Relationship for Rupture Stresses in Reinforced Plastics," Proceedings American Society of Testing Materials, Vol. 54, p.1344, 1954.
20. \_\_\_\_\_ "Long-Term Rupture and Impact Stresses in Reinforced Plastics." American Society for Testing Materials. ASTM Bulletin No. 224, September 1957.
21. \_\_\_\_\_ "Creep of Glass-Reinforced Elastics." American Society for Testing Materials, ASTM Bulletin No. 225, October 1957.

22. Larson, F. R. and J. Miller, "A time-temperature relationship for rupture and creep stresses." Transactions, American Society Mechanical Engineers, pp. 765-775 (1952).
23. Kuchkuda, Joan M. Effect of Prolonged Stress on Glass Reinforced Polyester Laminates. Picatinny Arsenal, Dover, N. J., Technical Notes 14, Ordnance Project TB4-721, Department of the Army Project 593-13-004, November (1957).
24. Goldfarb, P. M., Research on Methods for Determining the Shear Modulus of Glass Reinforced Plastic Laminates, Lab Project 5995-1, Final Report N.S. 034-045, Subtask 18, Material Laboratory, New York Naval Shipyard, August 31 (1959).
25. Goldfein, Solomon. "General formula for creep and rupture stress in plastics." Modern Plastics, Technical Section, April (1960).
26. Plastics: Method of Testing. Federal Test Method Standard Number 406, October 5 (1961).
27. Portland Cement Association, Design and Control of Concrete Mixtures. Ninth edition. (1948).
28. Ernst, George C., "Ultimate Slopes and Deflections, a brief for limit design." Proceedings of American Society of Civil Engineers. Vol. 81. Separate No. 583, January (1955).
29. Portland Cement Association. "Tentative Recommendations for Prestressed Concrete." (1958) Reprint from American Concrete Institute Proceedings, v. 54.

## VIII. ACKNOWLEDGMENTS

The author is indebted to Professor W. W. Payne for his guidance and assistance throughout the author's graduate studies.

Sincere appreciation is expressed to Dr. H. M. Morris, Head, Department of Civil Engineering, for assistance throughout the author's graduate studies.

Sincere appreciation is also expressed to Dr. G. A. Gray, Department of Civil Engineering, for his assistance throughout the author's graduate studies.

The author expresses thanks to \_\_\_\_\_,  
 \_\_\_\_\_,  
 \_\_\_\_\_,  
 and \_\_\_\_\_ for literature aiding this  
 thesis.

The author is indebted to \_\_\_\_\_, Columbia  
 Products Company; \_\_\_\_\_, Supreme Products Corpora-  
 tion; and \_\_\_\_\_ for donating materials, and to  
 \_\_\_\_\_ for the many hours of assistance given in the  
 laboratory.

**The vita has been removed from  
the scanned document**

## Abstract

### FIBER GLASS PRESTRESSED CONCRETE

by

Taylor F. Turner Jr.

The use of glass reinforcement in concrete was conceived over thirty years ago. However, it has been within the past ten years that the advantages of glass fiber over steel for use in prestressing have become known. Past research shows that, even though the physical properties of glass fiber in the form of laminated rods are desirable for prestressing concrete, the material presents several problems. The most difficult problem is that of gripping the fiber glass rods. Other problems are creep and developing adequate design criterion.

The present investigation confirms many of the previous findings with respect to gripping devices and presents data on tensile tests performed on modified commercial grips. The Fanngrip is the most promising commercial grip investigated.

Post-tensioned beams are designed and tested in flexure. The recorded test data is compared with the design data to verify existing design criterion. Present design formulas provide reliable results up to the cracking load. Deflections are calculated with sufficient accuracy by empirical equations; however, a method of finding ultimate load remains to be found.