

Effectiveness of Afterschool 4-H Enrichment Programs

By

Kaila Anglin

Report submitted to the Faculty of
Virginia Polytechnic Institute and State University
In partial fulfillment of the requirements for the degree of
Masters of Science in Agricultural and Life Sciences

Blacksburg, Virginia

Committee:

James C. Anderson II, Chair
Kim Niewolny
Kathleen Jamison

Abstract

The purpose of this project was to determine the effectiveness of afterschool 4-H enrichment programs to increase interest and participation in the Clarke County 4-H program. Ten of the youth program participants completed a survey to rate their level of satisfaction with the program, personal perception of science, and aspirations toward future participation in science activities. The results showed that 60% of the participants like to see how things are made or invented, get excited about science, and want to learn more about science; 70% of the participants like experimenting and testing ideas while 80% of the participants reported liking science; and 100% of the participants indicated at least some interest in participating in another afterschool science program. Recommendations were made to create a logic model that reflects intentional programming and opportunities for expanded evaluation, to conduct a follow-up survey or interview with youth participants in 3 to 6 months after participation in the program, to expand STEM learning opportunities to include in-school 4-H enrichment programs, to provide youth with choice of electives and 4-H projects based on interest and prior exposure and to conduct future studies to evaluate aspirations, awareness, and participation in afterschool programs that is contingent on school day participation in this content area is proposed.

Table of Contents

Chapter One	5
Introduction	5
<i>Background and Setting</i>	5
<i>Statement of the Problem</i>	6
<i>Purpose of the Project</i>	8
<i>Project Objectives</i>	9
<i>Definition of Terms</i>	9
<i>Limitations</i>	10
<i>Significance of the Problem</i>	10
Chapter Two	12
Review of Literature	12
<i>Education in the U.S.</i>	12
<i>Factors Impacting Youth Attendance</i>	13
<i>STEM Education</i>	14
<i>Expanding Learning Opportunities in Youth Development through 4-H</i>	16
<i>Theoretical Framework</i>	17
Chapter Three	20
Methodology	20
<i>Participants</i>	20
<i>Program Overview</i>	21
<i>Data Collection</i>	22
Chapter Four	23
Project Outcomes	23
<i>Overview</i>	23
<i>Program Evaluation</i>	23
Chapter Five	28
Conclusions and Implications	28
<i>Insights</i>	31

<i>Recommendations</i>	31
References	33
Appendix A: Pre-test and Post-test	39
Appendix B: Virginia 4-H Electricity School Enrichment Curriculum	40
Appendix C: Participant Survey	63
Appendix D: Teacher Survey	63
Appendix E: Promotional Flyer	66
Appendix F: Virginia 4-H STEM Program Logic Model	67

Chapter One

Introduction

Background and Setting

Traditionally, the 4-H program provided instruction in the format of community clubs and was centered on livestock and farming projects. Though in recent years, the demand to offer a variety of 4-H programs has dramatically increased. 4-H school enrichment programs are widespread and have expanded to serve more youth than any other delivery mode (Diem, 2001). Today, to support the research and evaluation mission, the 4-H program extends knowledge to children, youth, families, and communities by utilizing and providing education using research-based information.

The 4-H program also creates supportive communities that provide access and opportunities to youth through the acquisition of knowledge, skills, positive attitude, development of positive relationships, and engagement in behaviors that enable them to thrive (University of Georgia Cooperative Extension, n.d.). 4-H out-of-school programming, in-school enrichment programs, clubs and camps also offer a wide variety of science, engineering, technology and applied math educational opportunities (National 4-H Council, 2013). Thus, increased participation could mean participating in several activities or participating at a higher level in a few activities (Boyd, Herring, & Briers, 1992). The advantages of 4-H participation for contribution, educational achievement, and motivation for further education are robust (Lerner, Lerner, Phelps & colleagues, 2009). Therefore, 4-H participants are 1.6 times as likely as youth in other out-of-school-time (OST) programs to report better grades (“B and above” grades), 1.4 times as likely as youth in other OST programs to report high academic competence, 1.5 times as likely as youth in other OST programs to report high engagement in school, and 1.8 times as

likely as youth in other OST programs to expect to go to college (Lerner, Lerner & colleagues, 2009).

The 4-H program also provides training on applied research, program implementation and program evaluation to volunteers that conduct local 4-H programs. With 540,000 volunteers, 3,500 professionals, and more than 60 million alumni, the 4-H movement supports young people from elementary school through high school with programs designed to shape future leaders and innovators (National 4-H Council, 2013). For this reason it is critical to train the educators that play such a vital role in shaping today's youth and tomorrow's future.

Statement of the Problem

Regarding youth development specifically, Astroth (2003) reported that academic credentials and foundations for 4-H youth development work are strong. Since 1986, the 4-H professional research and knowledge taxonomy has provided a scholarly and theoretical framework for non-formal learning and positive youth development (Astroth, 2003). Currently, local, state, and national communities are emphasizing the importance of non-traditional 4-H programs being offered to youth participants and the impact they play in developing our youth. The Developing Positive Youth: Prepared & Engaged Youth Serving American Communities: National 4-H Impact Assessment Project indicated that youth should have opportunities to develop their potential to become self-directing and autonomous adults and realize that they can have an impact over their life's events (Peterson et al., 2001).

The main goal of the 4-H program for youth development focuses on the needs, concerns and interests of young people. Paid and volunteer staff members who work closely with 4-H youth helps them develop a positive self, teach them how to behave in society and increase the knowledge and skills they need to solve problems. This is achieved through completion of

individual projects, attendance at 4-H meetings and participation in group activities and various planned events. Consequently, the members develop new skills, learn to cooperate with their peers, improve leadership skills and increase citizenship involvement in their communities, all while having fun. In compliance with the official mission of empowering youth to reach their full potential, 4-H must find a way to incorporate more opportunities to help youth succeed (Harder, 2006). In Clarke County, families are looking for additional 4-H opportunities to enhance their children's overall 4-H experience outside of the traditional 4-H club. Therefore, additional efforts to establish and evaluate the effectiveness of non-traditional 4-H programs as well as collaborating with other organizations, school systems, and our communities are vital to the success of 4-H programs offered in our localities. Expanding the scope of programming to include parent, school, and community contexts should reflect diversity of populations in communities, and a variety of delivery modes.

In Extension, opportunities to work across 4-H youth and family program areas are an organizational advantage. 4-H Extension Agents witness how the 4-H program impacts the lives of youth and how the importance of establishing community partnerships affects the overall success of their county 4-H program. Helping youth fulfill their basic needs while developing competencies important to their immediate and future success is the role of the youth development professional (Norman & Jordan, n.d.). The 4-H Agent is also indirectly educating the 4-H member's parents by encouraging the youth to not only explore project areas that range from science to healthy living, but share their experiences with their families.

Accordingly, it is vital to have parents, volunteers, and community members –who are devoted to the positive development of young people helping and supporting the 4-H program in all facets. The caring support of adult volunteers and mentors inspires young people in 4-H to

work collaboratively (National 4-H Council, 2013). Without trained and caring individuals who have a desire to help 4-H youth reach their maximum potential, 4-H loses intentionality as a learning experience. Knowing that positive relationships with caring adults is an essential element of 4-H Club indicates to 4-H educators that they should support volunteer leaders to develop the qualities needed to relate well to young people (Grégoire, 2004). Throughout the 4-H experience, members develop a capacity to care for themselves and for the wellbeing of others around them and to follow through on projects (Grégoire, 2004). Well-trained volunteers assist in modeling and coaching these personal actions.

After training volunteers, the next step is interpreting the value of these programs to legislators, university administrators, and other key leaders. These groups must be made aware that 4-H activities don't simply teach youth skills in agriculture and home economics, but include non-formal, experiential educational programs that teach youth valuable life and content skills (Boyd, Herring, & Briers, 1992). 4-H continues to provide evidence that youth develop positive life skills and become contributing, productive citizens in their societies through lessons learned as a 4-H youth participant. According to the first Annual Report from the 4-H Study research showed that youth active in 4-H showed higher scores across critical PYD components (Lerner, Lerner, Phelps & colleagues, 2009).

Purpose of the Project

The purpose of this project is to determine the effectiveness of afterschool 4-H enrichment programs to increase interest and participation in the Clarke County 4-H program. This will be accomplished through increasing interest and excitement around science, technology, engineering and math (STEM) in out-of- school time learning and academic enrichment. 4-H exposes youth to different environments, introduces new information, provides

opportunities to learn about postsecondary education and ways to find these opportunities, and engages youth in fun and educationally challenging activities. Together, members, volunteer leaders, and parents of 4-H clubs provide a variety of educational workshops and physical activities that motivate youth to succeed. The 4-H Study of Positive Youth Development, shows youth engaged with 4-H are: nearly two times more likely to get better grades in school; nearly two times more likely to plan to go to college; 41 percent less likely to engage in risky behaviors; and 25 percent more likely to positively contribute to their families and communities (National 4-H Council, 2013).

Through continuous research efforts, 4-H involvement is proven to positively impact the lives of youth participants. The National 4-H Council also reported that young people in 4-H: report better grades, higher levels of academic competence, and an elevated level of engagement at school; are nearly two times more likely to plan to go to college; and are more likely to pursue future courses or a career in science, engineering, or computer technology (2013). The "Targeting Life Skills Model" (Hendricks, 1998) was developed at Iowa State University and also places 35 life skills into four major categories—Head, Heart, Hands, and Health (Harder, 2006).

Project Objectives

The objectives for this project are to: (1) increase the interest in 4-H youth of STEM learning opportunities; (2) increase benefits of youth participating in STEM; and (3) increase youth aspiration to participate in future STEM learning opportunities.

Definition of Terms

Experiential learning (EL) – "the process whereby knowledge is created through the transformation of experience. Knowledge results from the combination of grasping and

transforming experience"(Kolb 1984, p. 41); a holistic integrative perspective on learning that combines experience, perception, cognition and behavior.

Positive Youth Development (PYD) – the approach that emphasizes providing services and opportunities to help youth develop a sense of competence and belonging and to help them to acquire the knowledge and skills they need to become healthy and productive citizens in their communities (Commission on Children and Families, n.d.).

Extension Leadership Council (ELC) – council formed of local stakeholders and community members that support Cooperative Extension and their programs (Kaufman, 2009).

Limitations

Due to limited time, resources, and access to target population, a convenience sample was used for the evaluation of the program. As a result, the outcomes of this program are limited to the participants and cannot be used to generalize to a larger population. Additionally, baseline data on students' interests in STEM were not collected nor were proper experimental procedures employed to make a definitive claim that the program increases interests in STEM. Although, an increase in interest was not determined based on the results, the data did indicate that students were not discouraged from pursuing interest in STEM-related subjects after participating in the program.

Significance of the Problem

Studies show that youth that youth who participate in 4-H clubs and programs do better in school, are motivated to help others, develop leadership life skills, public speaking, increase self-esteem, accept greater responsibility, increase communication and planning skills, and are making lasting friendships (Junge, 2006). Therefore, local stakeholders in Clarke County such as the Public Schools, ELC, and Clarke County Farm Bureau identified the need to take additional

steps to enhance learning and life skill development through afterschool enrichment programs like those offered through 4-H.

Chapter Two

Review of Literature

Education in the U.S.

The educational achievement and attainment of young people in the United States has been a longstanding concern. Over time, some basic assumptions have been made about our education system; one being that time-based testing measures educational attainment. Therefore, our students simply learn to memorize content but do not have the necessary skills to apply it to their everyday lives. Another basic assumption is the way we establish our classrooms and learning environments often organizing students into age-determined roughly equal sized groups where separate academic disciplines and learning occurs with all the students in a particular class receiving the same content at the same pace. Today, the focus of our education system is shifting from “teaching” to “learning” where educator roles are beginning to change from primarily lecturing to “designers of learning methods and environments” (Barr & Tagg, 1995) while Brookfield (1985) argues that the role of teachers is to “facilitate” the acquisition of content knowledge.

The National Education Technology Plan, *Transforming American Education: Learning Powered by Technology* (2010) is the U.S. Department of Education’s plan to transform our education system through technology to improve student learning, accelerate the use of effective practices, and use data and information for continuous improvement. Overall, the plan addresses technology trends that could transform education, such as mobility and accessibility, using digital content and online social networks for collaboration and learning; however, the plan stresses that technology in the classroom only works when paired with effective teaching. In an interview during the State Educational Technology Directors Association Education Forum, U.S.

Education Secretary Arne Duncan stated, "Technology will never replace good teachers. We all know that the most important factor in a student's success is the teacher leading the class. That will not change" (U.S. Department of Education, 2010).

Factors Impacting Youth Attendance

Improving School Attendance: A Resource Guide for Virginia Schools developed by the Virginia Department of Education focuses on the importance of school attendance, the significance of truancy and the many causes of truancy. Truancy, at its most basic, means unexcused absence from school; however, in the absence of a legal definition, the Virginia Department of Education is using a proxy measure to report truancy: the number of students with whom a conference was scheduled after the student had accumulated six absences during the school year, in accordance with '§22.1-258, Code of Virginia (Virginia Department of Education, 2005). Truancy is a multifaceted problem and by examining truant behaviors, educators can begin to understand which students are experiencing some sort of barrier to learning.

Today, students often find education irrelevant for several reasons including that the course does not interest them, they fail to recognize the value of what they are learning, or that many teachers rely heavily on lectures for transmitting information. If you walk into most classrooms today, you are more than likely to still find a teacher standing at the front of the room delivering content to a large group of students; however, few students tend to grasp the content while many struggle to follow along or ultimately disengage altogether. One way student disengagement can be observed in classrooms across our nation is through declining course attendance or lack of school attendance overall.

Building a Culture of Attendance: Schools and Afterschool Programs Together Can and Should Make a Difference, the leaders of SHINE (Schools and Homes in Education) Afterschool

Program conducted a study that recently resolved to improve the school-day attendance for the students at their 21st Century Community Learning Centers in rural Pennsylvania (Chang & Jordan, n.d.). To improve school-day attendance, students in the program were offered incentives including that they were unable to attend the afterschool program if they did not come to school during the school day. The of the study results show that a school attendance rate significantly higher than similar programs nationally, improved communications with parents, and a remarkable collaboration with school teachers that could prove a model for out-of-school-time programs” (Chang & Jordan, n.d.). Data analysis of this study demonstrates that the more students attend SHINE afterschool program, the better they do in school and the more regular their attendance was during the school day. Specific results showed that 88% of the SHINE students had satisfactory school-day attendance, 96% of SHINE students were promoted to the next grade, and altogether 78% of the SHINE students improved their academic performance (Chang & Jordan, n.d.).

STEM Education

Today’s society is largely based on the advancements of science and technology. Many students’ lives today are filled with technology that gives them mobile access to information and resources anytime, anywhere. However, the challenge remains for our education system to leverage learning science and modern technology to create engaging, relevant, and personalized learning experiences for all learners. Carl Wieman (2007), author of *Why not try a scientific approach to science education?* argued that we need a more scientifically literate populace to address global challenges, as well as to make wise decisions, informed by scientific understanding. The modern economy is largely based on science and technology and for that economy to thrive and for individuals within it to be successful, we need technically literate

citizens with complex problem-solving skills (Wieman, 2007). Therefore, as a society of educators, we need to make science education effective and relevant for today's youth. In doing so, Wieman suggests that we utilize modern technology in our education system. By making education relevant to our students through applicable concepts like STEM and utilizing technology as a tool to help facilitate learning, students begin to develop skills in communication, teamwork, critical thinking and problem solving, and even have the ability and desire for lifelong learning.

STEM Learning in Afterschool: An Analysis of Impacts and Outcomes, the Afterschool Alliance- an alliance of public, private, and nonprofit groups committed to raising awareness and expanding resources in afterschool programs, conducted a 10-month study that asked experienced afterschool providers and supporters to identify appropriate and feasible STEM outcomes for youth in afterschool programs. Three major outcomes were identified and the consensus is that afterschool programs help youth to: (1) develop an interest in STEM and STEM learning activities, (2) develop capacities to productively engage in STEM learning activities, and (3) come to value the goals of STEM and STEM learning activities (Afterschool Alliance, 2011). Increasing interest early on is critical so that students are motivated to develop the knowledge and skills required to pursue STEM courses in high school. While improvements in formal K-12 education systems nationwide are necessary, children spend less than 20 percent of their waking hours in school; therefore, opportunities lie in all aspects of student education, including enrichment programs that take place during the afterschool hours and the summer (Afterschool Alliance, 2011).

Expanding Learning Opportunities in Youth Development through 4-H

Increasing the number of hours that today's youth attend school every year has become an increasingly popular suggestion to remedy poor school performance and widespread education gaps; however, research examining extended school-day models is not conclusive (Redd et al., 2012). Thus, 4-H afterschool educational programs fit the bill. 4-H educational programs are offered to youth outside of school hours, usually during the times parents or guardians are in need of safe, caring and enriching environments that offer expanding learning opportunities for their children. Afterschool educational programs, such as 4-H, engage youth in real-world problems where the instructor helps facilitate learning by probing students on their thought processes and giving them guidance as they analyze, debate, and solve problems. Wieman (2007) suggests that after some time is spent in an primarily facilitated environment rather than a lecturing environment, students will turn into experts because they are actively engaged in cognitive processes that are required for developing expert competence.

In Evaluating the 4-H Science Initiative: The 2010 Youth, Engagement, Attitudes and Knowledge (YEAKE) Survey, 4-H youth were asked to report in a self-guided questionnaire their length of involvement in 4-H Science programs and how many hours per week they spent in those programs. Older 4-H youth, ages 13-18, reported they were capable of: recording data accurately (76 percent), using data to create a graph for presentation to others (75 percent), and using the results of an investigation to answer the questions asked (73 percent) (National 4-H Council, 2010). Fifty percent of the respondents also reported they want to pursue a science career, seventy-one percent of the 4-H Science participants said science is one of their favorite subjects, and fifty-nine percent of the respondents would like to have a job related to science when they graduate from school (National 4-H Council).

Theoretical Framework

Experiential learning (EL) will be used as the theoretical framework for this project to guide activities and increase youth knowledge about scientific inquiry and participation in nontraditional 4-H programs. The foundational premise of experiential learning is that experience matters. Thus, there needs to be a sequence of three discrete components: 1) A “concrete **experience**” (Enfield, 2001, Kolb, 1984), where the learner is involved in an exploration, actually doing or performing an activity of some kind; 2) a “contemplation” phase, which is usually referred to in the literature as a **reflection** stage (Enfield, 2001; Kolb, 1984; Pfeiffer & Jones, 1981), whereby the learner reflects, shares reacts and observes publicly, discussing and analyzing the experience; and 3) the “**application**” phase that helps the learner deepen and broaden their understanding of the concept or situation by cementing their experience through generalizations and applications (Carlson & Maxa, 1998). Another key point of the process is that it is cyclical, referred to as a "recurring cycle" by Kolb (1984).

The Experiential Learning Model developed by Pfeiffer and Jones (1985) and modified by 4-H includes five specific steps: (1) participant(s) experience the activity – perform or do it; (2) participant(s) share the experience by describing what happened; (3) participant(s) process the experience to determine what was most important and identify common themes; (4) participant(s) generalize from the experience and relate it to their daily lives; (5) participant(s) apply what they learned to a new situation (see Figure 1). The Experiential Learning Model encourages a hands-on exploration by learners with guidance from an adult facilitator. When this model is used, youth both experience and process the activity. They learn from personal and peer thoughts and ideas about the experience; thus, each step contributes to their learning.

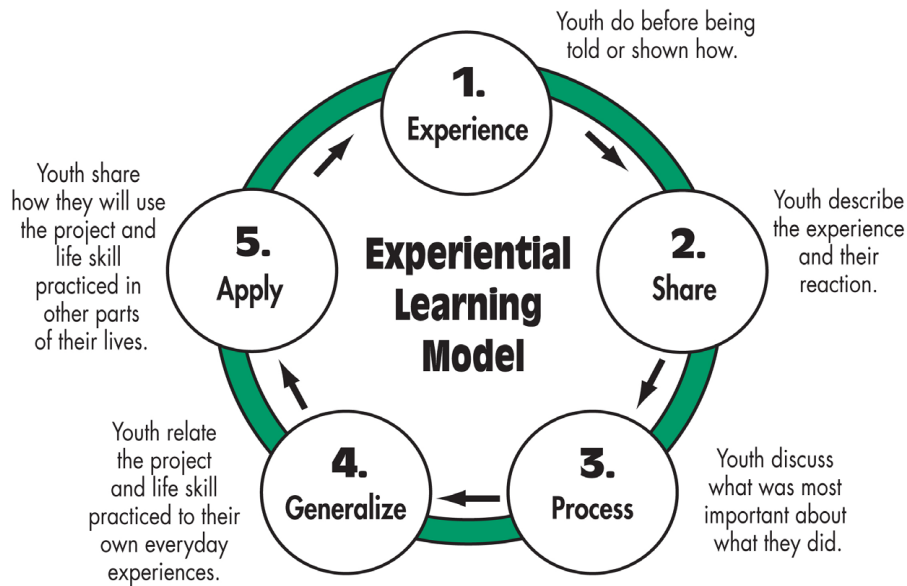

Pfeiffer, J.W., & Jones, J.E., "Reference Guide to Handbooks and Annuals"
© 1983 John Wiley & Sons, Inc.
Reprinted with permission of John Wiley & Sons, Inc.

Figure 1: Experiential Learning Model

As stated, the first step in the model is experience. Providing an experience alone does not create experiential learning; students need to be presented with a problem, task, situation or activity and be able to interact with it. The participant should then be able to understand what happened and hopefully sees patterns in their observations. The second step is that the participant should be able to generalize the observations and be able to “share” with other participants and their peers their findings.

Next, “processing” the experience is what moves an experience beyond “learning by doing.” The primary purpose of processing is to allow participants the opportunity to integrate their learning and have a sense of completeness to their experience. In order for youth to take what they have just experienced and use it effectively in their everyday lives, they must think about it and interpret its meaning for themselves (Hammel 1986). It is this reflective processing

that takes place after the initial hook or involvement that sets experiential learning apart from simply “experiencing” or “doing” an activity.

Lastly, the “generalizing” and “applying” processing steps of the experiential learning model help expand the participant’s learning potential. Open-ended questioning works best to promote inquiry and helps the participant make connections and apply their learning experiences to real-life situations in the future. If the questions help youth explore the activity from their own perspectives, relate it to their own lives and see how to apply what they learned, then the goal has been reached. However, if the questions are perceived by the participants to be a test of their knowledge, then much of the benefits of using the experiential model are lost and participants will only respond to the questions based on the “correct answer” not on what their experience.

According to this theory, if a participant gained knowledge by participating in the after-school science program, he would likely have an increased interest in learning more about science. The likelihood that he would actually participate in other science-based 4-H programs would also be increased. Using this framework, the after-school 4-H science program would, in theory, ultimately help increase participation within other 4-H programs by providing participants with additional experiential and deepened content learning opportunities.

Chapter Three

Methodology

Increasingly policy makers, community funders, and youth program educators are looking for concrete ways to see that the dollars and effort they expend on programs indeed have a positive impact on the youth they are intended to serve. As a result, afterschool programs including 4-H programs are turning their attention and efforts to effectively evaluate those programs. Thus, this project used a variety of assessment methods to provide a better-rounded picture of the afterschool 4-H science program.

Participants

The afterschool 4-H science program took place at Boyce Elementary School (BES) in Boyce, VA and D. G. Cooley Elementary School (CES) in Berryville, VA and targeted youth in grades 3rd to 5th grade. The program was open to all youth at BES and CES within those grades and registration was permitted on a first-come, first-serve basis. The 4-H agent served as the instructor while parent volunteers, club leaders, and teen 4-H members served as facilitators for the length of the program. The population sample was collected from the 4-H enrollment form in which youth participants indicated their race, gender, and ethnicity. From this information, the afterschool 4-H program population sample relative to the county population as a whole was able to be identified. This information was entered into the online 4-H Access database and was generated through the ES-237 Federal Report which maintained accurate records for the population sample throughout the length of the program. This database also allowed the 4-H agent to determine which youth crossover into different 4-H programs and project areas and/or become long-standing 4-H members by showing their participation levels in different programs

as a result of participating in the afterschool 4-H science program at Boyce Elementary School and D.G. Cooley Elementary School.

The 4-H Access database allows the 4-H agent to re-enroll 4-H youth members in a specific project. The enrollment process includes the 4-H agent documenting the projects or activities of interest chosen by the youth member. The 4-H agent can then sort the entire database for youth year by length of enrollment in specific activities and years of participation.

Program Overview

This project was implemented in the spring of 2014 at Boyce Elementary School in Boyce, VA and D. G. Cooley Elementary School in Berryville, VA. For the purposes of this project, regular evaluations were used to provide feedback on the effectiveness of the program's work and to help focus efforts to improve the program by targeting the areas in greatest need of change such as more programming time, pairing groups with similar interests or academic levels, and even changing the topic areas on a frequent basis.

A pre-post evaluation of science terminology and the youth participants' interest in science programs was given on the first and last day of the program sessions (see Appendix A). The Virginia 4-H Electricity School Enrichment Curriculum was used for the Simply Science Afterschool 4-H Program (see Appendix B). The pre-post evaluation indicators were chosen in alignment with the Standards of Learning for the 4th grade level. Although, the curriculum was written in correlation with 4th grade electromagnetism standards the participant grade level range was 3 through 5. During each afterschool session youth were asked to complete the knowledge assessment that was associated with each corresponding lesson. Using the knowledge assessment results, the researcher was able to construct engaging, hands-on activities to reinforce STEM concepts.

Data Collection

An overall evaluation survey was developed by the researcher and reviewed by the school administrator at the school where the enrichment program took place. This ensured that the data collected was applicable both to the 4-H program and the public school system. The survey methodology was used to collect the participants' perception of the afterschool 4-H enrichment program and the knowledge gained from participating in the program. Various questions were asked including the participant's level of satisfaction with the program, personal perception of science, and future participation in science activities.

At the conclusion of the afterschool 4-H enrichment program, all participating youth were asked to complete voluntary questionnaires (see Appendix C). Their answers remained confidential and were used in an aggregated report that included survey results from one other afterschool 4-H program. No youth information was identifiable on the survey or through the collection process. Also, their participation in the survey was entirely voluntary and did not affect whether they could participate in the afterschool 4-H program. There were no known risks for the participants. The survey completion time was approximately 15 minutes.

Additionally, teachers and facilitators who were responsible for organizing, conducting, or coordinating 4-H school enrichment programs in their classrooms were also invited to participate in a post-program survey (see Appendix D). A printed questionnaire was mailed to the teachers and facilitators and email reminders were sent to maximize response. Teachers were able to provide feedback on how the curriculum relates to the Experiential Learning model and answer questions on their perception of the curriculum in achieving the program objectives.

Chapter Four

Project Outcomes

Overview

Ten of the 15 participating youth responded to the participant survey and three of the 5 participating teachers and facilitators responded to the teacher survey. The survey data was transferred to an Excel spreadsheet. One hundred percent of the surveys collected were used as data and analyzed. Five of the 15 participating youth did not complete the survey due to lack of attendance on the post-testing day. The research project results were based on the ten youth participants and three participating teachers with completed surveys. The researcher acknowledges that the results of this evaluation are not generalizable and are only representative of the participants that responded.

Demographic information collected consisted of age, grade, and gender of the youth participants. The gender split for respondents was equal with five girls and five boys. Four of the respondents were 9 years old, forty percent of the participants were 10 years old, and the remaining two were 11 years old. Additionally, five respondents were in the 4th grade and the other five were in the 5th grade.

Program Evaluation

The responses from the participants indicated that the majority of the youth had an interest in STEM, benefited from participating in a STEM program, and expressed aspiration for participating in future STEM learning opportunities. Objective one was to increase the interest of 4-H youth in STEM learning opportunities. Although this evaluation did not explicitly measure if interest increased after the program, an assessment of if the majority of the participants expressed some interest in science was possible. It is hypothesized that if the majority of students

exposed to STEM activities express an interest in STEM, then exposing more students to these activities will lead to an increase in interest overall.

To assess interest, youth participants were asked to express their personal feelings about science (see Table 1). Sixty percent of the participants responded that they like to see how things are made or invented, that they get excited about science, and that they want to learn more about science. Seventy percent of the participants responded that they like experimenting and testing ideas while eighty percent of the participants responded that they like science. Sixty percent of the participants felt that they are sometimes good at science while fifty percent said they do science activities that are not for school.

Table 1
Participant Personal Feelings about Science

Item	Yes	No	Maybe
I do science activities that are not for school.	5	3	2
I would like to have a job related to science.	2	4	3
I am good at science.	4	6	0
I like science.	8	2	0
I want to learn more about science.	6	4	0
I get excited about science.	6	4	0
I like experimenting and testing ideas.	7	3	0
I like to see how things are made or invented.	6	4	0

Objective two was to increase benefits of youth participating in STEM. Participants were asked to describe their favorite part of the program. The majority of the responses were related to

hands-on experiences or experiential learning. Additional responses were related to interacting with others. Specific responses from the participants were:

“I was with my friends and learned at the same time.”

“Building things and having fun.”

“When we learned how to make a light bulb come on by using batteries, battery holders, wires and lights. Then they formed a circuit or circle.”

“Meeting new people.”

“Experiments.”

“Making circuits.”

“The circuits.”

“Using magnets.”

“Learning everything.”

Objective three was to increase youth aspiration to participate in future STEM learning opportunities. Participants were asked if they would like to attend the science program again. Of the 10 participants surveyed, all of the participants indicated at least some interest in participating in another afterschool science program. Seven responded yes and three responded maybe.

To evaluate the Virginia 4-H Electricity School Enrichment Curriculum as to how it is an appropriate reflection of the five specific steps of the Experiential Learning model, teachers and facilitators were asked to rank their responses from strongly disagree to strongly agree and then asked to provide feedback on their response. As the first step of the Experiential Learning model is to experience, teachers were asked if the curriculum provides students with the opportunities to explore, examine, or arrange through hands-on learning experiences. Of the 3 teachers

surveyed, all indicated they strongly agreed with that statement and provided the following responses:

“Many experiments, uses circuits- batteries, wires, etc. (open/ closed) to explore.”

“Students love to hold materials in their hands, the excitement really ramps up when they get hands-on and interest.”

To assess the second step, share, in the Experiential Learning model, teachers and facilitators were asked if the curriculum provides students with the opportunity to share what happened through their results and reactions. One hundred percent of the teachers strongly agreed with the statement and provided the following responses:

“Students became excited about science.”

“Students enjoy the challenge and experience of their hands-on experiment.”

“I put them in teams, this allows sharing. When the first group has success, the share and help those who are not getting it.”

To evaluate the third step, process, in the Experiential Learning model teachers and facilitators were asked if the curriculum provides students with an opportunity to discuss and analyze their results. Of the 3 respondents, all indicated they strongly agreed and provided the following responses: feedback was given throughout experiments; good responses to questions about the experiment; we discuss what worked, what did not, and the reasons. They are interested since they experienced it.

To assess the fourth step, generalize, in the Experiential Learning model teachers and facilitators were asked if the curriculum provides students with an opportunity to connect their experiences to real-world examples. Of the 3 respondents, two indicated they strongly agreed and one indicated they agreed with the statement. They also provided the following responses:

Mr. Thomas provided many examples of electricity in the real-world; as best as possible- home lights vs Christmas tree; hooking up multiple bulbs to one battery, too many and light dims, compare to lights dimming on overloaded circuit.

To evaluate the last step, apply, in the Experiential Learning model, teachers and facilitators were asked if the curriculum provides students with an opportunity to apply and practice what they learned. Of the 3 respondents, two indicated they strongly agreed and one indicated they were neutral on the statement. They also provided the following responses: students were given time to do experiments on their own; at most a better grasp of concept; encourage home check of appliance labels, look at breaker box, do safety check.

To assess whether you will have an increased interest in STEM learning opportunities, benefit from participating in STEM learning opportunities, and aspire to participating in future STEM learning opportunities as a result of participating in a program that utilizes the Virginia 4-H Electricity School Enrichment Curriculum and emphasizes on experiential learning, teachers were asked to respond 'yes' or 'no' and then provided an additional comment box on the teacher survey. All three respondents answered yes to all three questions and specific responses were:

“We have enjoyed this program for a number of years and watching the students’ enthusiasm and curiosity is a joy.”

“Great project that can be delivered in many ways.”

“We look forward to [presenter] coming in each year to do his science lesson.”

Chapter Five

Conclusions and Implications

The purpose of this project was to determine the effectiveness of afterschool 4-H enrichment programs to increase interest and participation in the Clarke County 4-H program. Although, an increase in interest was not determined based on the results, the data did indicate that students who participated in the program were not discouraged from pursuing interest in STEM-related subjects. Implications gained from this study included facing unexpected challenges and recognizing positive student growth. For example, students at the 3rd grade level became frustrated when they faced challenges that required a stronger skill set or prior knowledge. Often, 5th graders became bored or disengaged when they had stronger skill sets than the activity required. Considerations for a study expansion could include a more homogenous group of youth based on their skill, grade, or experience level. When an adult facilitator/leader was assigned to the groups that were having difficulty, students were more engaged and successfully completed the assigned activities. This finding stresses the need for an adult facilitator who recognizes struggling students and is effectively available to address student concerns as needed.

Another goal was to increase the academic enrichment opportunities available to youth to participate in programs that revolve around STEM concepts. The major findings showed that youth were eager and excited to expand their knowledge about STEM concepts and participation in future STEM learning opportunities. Additional findings showed that youth were eager and excited to participate in hands-on activities and indicated a desire to participate in future STEM learning opportunities. Although, pre-post knowledge tests were given, results were inclusive on increased knowledge gains.

Responses from teacher surveys indicated a strong gain in participants' interests in and aspirations toward participating in STEM-related learning opportunities using Experiential Learning model concepts. By using multiple senses through an experiential learning cycle - experience, share, process, generalize, and apply- youth experience an increase in knowledge retention. Also, by placing students in groups and allowing for pair-share or group discussion allows youth to share and generalize their experiences, which ultimately allowed them to build on their experiences by applying and practicing what they learned. For example, youth were encouraged to think about the circuits they encounter on a daily basis such as home appliances, Christmas tree lights or even their home breaker boxes and then a discussion was carried out about how those specific examples employ the basic electricity terms and circuits they built using the Virginia 4-H Electricity School Enrichment Curriculum.

The findings shed light on what may be the crux of the issue when it comes to the need for 4-H youth participation and the importance of positive youth development afterschool STEM programs. The immediate effects and long-term impact of 4-H programs may not be realized by evaluating a short-term program as a one-shot case study. However, the current literature and the findings with this group of participants demonstrate that there is a significant need to introduce youth at the elementary school age to programs that encourage exploration of different interest areas in a safe, positive environment.

As the Afterschool Alliance discovered through their 10-month study, afterschool programs help youth to: (1) develop an interest in STEM and STEM learning activities, (2) develop capacities to productively engage in STEM learning activities, and (3) come to value the goals of STEM and STEM learning activities (Afterschool Alliance, 2011). The benefits of youth participating in 4-H STEM learning opportunities include: (1) lifelong learning where youth

become invested in their own learning and (2) engaging, hands-on activities where youth gain practical application skills. Afterschool 4-H STEM enrichment programs allow youth to get the hands-on real world experience they need to become tomorrow's leaders. They can gain the knowledge, skills, and confidence that are needed in order to succeed in life and become productive, contributing citizens in their communities.

Another benefit that youth gain from participating in STEM programs is that they aspire to participate in future STEM learning opportunities, become life-long learners or possibly hold careers in STEM related fields because they are more aware. Thus, afterschool STEM programs that are strategically placed in underserved and underrepresented communities help close the opportunity gap that many children and youth face when programs are offered in locations that they cannot attend. In an effort to reduce school absences, afterschool STEM programs can also be utilized to provide students more time on STEM competencies through quality learning environments. Policy makers have higher confidence in afterschool STEM programs' abilities to impact skills such as problem-solving abilities, demonstrating STEM skills, career awareness and "21st century skills" such as teamwork. Therefore, these skills are as important as academic outcomes for the longer term to broaden access, program participation, and to maintain an interest in STEM fields and careers.

Nevertheless, there is great value in 4-H programs and discovering what is of importance to today's youth and developing new programs that focused on that interest and retaining their attention long-term will increase participation in the overall 4-H program. The results of this study support this argument and further emphasize the need for change in approaching the way we create STEM learning opportunities for 4-H youth.

Insights

There is a need for better articulation of program impact on student learning and attitudes towards STEM education. Although, considerations from Virginia 4-H STEM Program Logic Model (see Appendix F) were utilized in the initial program design, there wasn't enough attention paid to aligning the activities and the processes through the outcomes of the program to provide strong context for evaluation.

There is a need to develop additional enrichment opportunities to deepen out-of-school project time and scaffold in-school learning through electives.

Recommendations

Four recommendations were gleaned from the findings. They are:

1. Create a logic model that reflects intentional programming and opportunities for expanded evaluation. For example, measures could be used such as parent interviews, focus groups and youth follow-up after a 3-6 month period.
2. Conduct a follow up survey or interview with youth participants in 3 to 6 months after participating in the program. This would assess whether the youth participants program experience has changed their perception about STEM leading them to participate in other 4-H STEM programs.
3. Expand STEM learning opportunities to include in-school 4-H enrichment programs. Since 4-H curricula is designed to enhance existing classroom STEM units, students participating in in-school 4-H enrichment opportunities would be exposed to similar hands-on, experiential science learning opportunities as the youth who participate in afterschool 4-H enrichment programs.

4. Provide youth with choice of electives and 4-H projects based on interest and prior exposure.
5. Conduct future studies in increased aspirations, increased awareness, and comparison of afterschool participation that is contingent on school day participation in this area is proposed.

References

- Astroth, K. A. (2003). Doorway, doormat, or doghouse? The Challenges Facing 4-H Youth Development Scholarship in Land-Grant Universities. *Journal of Extension*, 41(6).
- Afterschool Alliance. (2009). America After 3pm. Retrieved from <http://www.afterschoolalliance.org/AA3PM.cfm>
- Afterschool Alliance. (2011). STEM Learning in Afterschool: An Analysis of Impacts and Outcomes. Retrieved from <http://www.afterschoolalliance.org/STEM-Afterschool-Outcomes.pdf>
- Afterschool Alliance. (2011). Afterschool: A Vital Partner in STEM Education. Retrieved from http://www.afterschoolalliance.org/Afterschool_as_STEMpartner.pdf
- Afterschool Alliance. (2012, April 13). The Expanded Learning and Afterschool Project: Afterschool Programs Improve Attendance, Behavior and Coursework. Retrieved April 13, 2014, from <http://search.proquest.com.ezproxy.lib.vt.edu:8080/docview/963985521>
- Afterschool Alliance. (2013). Afterschool Programs: Making a Difference in America's Communities by Improving Academic Achievement, Keeping Kids Safe and Helping Working Families. Retrieved from http://www.afterschoolalliance.org/Afterschool_Outcomes_2013.pdf
- Barr, R.B., and Tagg, J., 1995, From Teaching to Learning: A New Paradigm for Undergraduate Education. *Change*, v. 27, p. 13-25.
- Beede, D. et. al, (2011). Education Supports Racial and Ethnic Equality in STEM. Retrieved from <http://esa.gov/Reports/education-supports-racial-and-ethnic-equality-stem>
- Beede, D. et al, (2011) Women in STEM: A Gender Gap to Innovation. Retrieved from <http://esa.gov/Reports/women-stem-gender-gap-innovation>

- Bourdeau, V. D. (2004). 4-H Experiential Education-A Model for 4-H Science as Inquiry. *Journal of Extension, 42*.
- Boyd, B., Herring, D., & Briers, G. (1992). Developing Life Skills in Youth. *Journal of Extension, 30, (4)*.
- Brookfield, S.D., editor, 1985, Self-Directed Learning: From Theory to Practice. New Directions for Adult and Continuing Education, no. 25. Jossey-Bass Publishers, San Francisco, CA.
- Cannon, J., Broyles, T., Seibel, G. & Anderson, R. (2009). Summer Enrichment Programs: Providing Agricultural Literacy and Career Exploration to Gifted and Talented Students. *Journal of Agricultural Education, 50(2)*.
- Chang, H. N., & Jordan, P. W. (n.d.). Building a Culture of Attendance: Schools and Afterschool Programs Together Can and Should Make a Difference. *Expanded Learning & Afterschool: Opportunities for Student Success*. Retrieved April 13, 2014, from http://www.expandinglearning.org/docs/chang_jordan.pdf
- Commission on Children and Families. (n.d.) Best Practices: Positive Youth Development. Retrieved from <http://www.npcresearch.com/Files/StrengthsTrainingBinder/44.BestPracticiesPositiveYouthDevelopment.pdf>
- Diem, K. (2001). National 4-H School Enrichment Survey. *Journal of Extension, 39(5)*.
- Diem, K. (2009). Preparing Youth Development Professionals to Be Successful: How Do the Needs of Extension/4-H Compare to Those of Other Organizations. *Journal of Extension, 47(1)*.
- Each day in America. (2011). Retrieved from <http://www.childrendefense.org/childresearch-data-publications/each-day-in-america.html>

- Educate to Innovate. (n.d.). *The White House*. Retrieved from <http://www.whitehouse.gov/issues/education/k-12/educate-innovate>
- Enfield, R., Schmitt-McQuitty, L., & Smith, M. (2007). The Development and Evaluation of Experiential Learning Workshops for 4-H Volunteers. *Journal of Extension*, 45(1).
- Ferrari, T. & Turner, C. (2006). An Exploratory Study of Adolescents' Motivations for Joining and Continued Participation in 4-H Afterschool Program. *Journal of Extension*, 44(4).
- Gestsdóttir, Steinunn; Lerner, Richard M. (2007). Intentional Self-regulation and Positive Youth Development in Early Adolescence: Findings from the 4-H Study of Positive Youth Development. *Developmental Psychology*, 43(2).
- Grégoire, H. (2004). Gathering Wisdom from 4-H Youth Development Clubs. *Journal of Extension*, 42(3).
- Harder, A. (2006). The Neglected Life Skill. *Journal of Extension*, 44(1).
- Junge, S. (2006). *4-H Afterschool Resource Guide: 4-H Youth Development Programming in Underserved Communities*. Retrieved from <http://www.4-h.org/Programs/Afterschool/4-H-Youth-Development-Programming-in-Underserved-Communities.dwn>
- Kaufman, E. (2009). Extension Leadership Councils: Planning for Success. Publication 490-394. Retrieved from http://pubs.ext.vt.edu/490/490-394/490-394_pdf.pdf
- Krishnamurthi, A., Bevan, B., Coulon, V. R., & Rinehart, J. (2013, January 1). Defining Youth Outcomes for STEM Learning in Afterschool. *Afterschool Alliance*. Retrieved April 13, 2014, from http://www.afterschoolalliance.org/STEM_Outcomes_2013.pdf
- Kolb, D. A. (1984). *Experiential learning: Experience as the source of learning and development*. New Jersey: Prentice-Hall.

Langdon, D., McKittrick, G., Beede, D., Khan, B., & Doms, M. United States Department of Commerce, (2011). *Stem: Good jobs now and for the future*. Retrieved

<http://www.esa.doc.gov/Reports/stem-good-jobs-now-and-future>

Lerner, R. (2005). Positive Youth Development, Participation in Community Youth Development Programs, and Community Contributions of Fifth-Grade Adolescents : Findings From the First Wave of the 4-H Study of Positive. *The Journal of Early Adolescence, 25(1)*.

Lerner, R. M., Lerner, J. V., Phelps, E. and colleagues. (2009). Waves of the Future: The First Five Years of the 4-H Study of Positive Youth Development. *National 4-H Website*.

Retrieved from <http://www.4-H.org>

Lerner, R.M., Lerner, J.V. and colleagues. (2009). Waves of the Future- 2009: Report of the Findings from the First Six Years of the 4-H Study of Positive Youth Development.. Retrieved from http://www.4-h.org/uploadedFiles/About_Folder/Research/Tufts_Data/4-H-Positive-Youth-Development-Study-Wave-6.pdf

National 4-H Council. (2010). Evaluating the 4-H Science Initiative: The 2010 Youth, Engagement, Attitudes and Knowledge Survey Results. Retrieved from http://www.4-h.org/uploadedFiles/About_Folder/Research/Science/FinalYEAKReport.pdf

National 4-H Council. (2013). National 4-H website. Retrieved from <http://www.4-h.org/about/youthdevelopment-organization/>

Norman, M. N., & Jordan, J. C. (n.d.). *United States Department of Agriculture*. Retrieved from http://www.csrees.usda.gov/nea/family/res/pdfs/Targeting_Life_Skills.pdf

University of Georgia Cooperative Extension. (n.d.). Outlook 2012: Trends, Issues, and Resources. Retrieved from

[http://www.caes.uga.edu/intranet/coextopr/development/documents/2012_outlook_state
ment_book.pdf](http://www.caes.uga.edu/intranet/coextopr/development/documents/2012_outlook_state_ment_book.pdf)

Paisley, J. & Ferrari, T. (2005). Extent of Positive Youth-Adult Relationships in a 4-H After-School Program. *Journal of Extension*, 43(2).

Peterson, W. L., Gerhard, G., Hunter, K., Marek, L., Phillips, C., & Titcomb, A. (2001). Developing Positive Youth: Prepared & Engaged Youth Serving American Communities: National 4-H Impact Assessment Project. Retrieved from <http://www.ca4h.org/files/13698.pdf>

Price, M. (2012, July 06). Pushing Students Toward STEM. *Science Career Magazine*, Retrieved from [http://sciencecareers.sciencemag.org/career_magazine/previous_issues/articles/
2012_07_06/carecredit.a1200076](http://sciencecareers.sciencemag.org/career_magazine/previous_issues/articles/2012_07_06/carecredit.a1200076)

Redd, Z., Boccanfuso, C., Walker, K., Princiotta, D., Knewstubb, D., & Moore, K. (2012, August). *Expanding Time for Learning Both Inside and Outside the Classroom: A Review of the Evidence Base*. Retrieved from [http://www.wallacefoundation.org/knowledge-
center/summer-and-extended-learning-time/extended-learning-
time/Documents/Expanding-Time%20for-Learning-Both-Inside-and-Outside-the-
Classroom.pdf](http://www.wallacefoundation.org/knowledge-center/summer-and-extended-learning-time/extended-learning-time/Documents/Expanding-Time%20for-Learning-Both-Inside-and-Outside-the-Classroom.pdf)

Seevers, B., & Graham, D. (2012). *Education through Cooperative Extension*. (3rd ed.). Fayetteville, Arkansas: University of Arkansas.

U.S. Department of Education. (2010). *Transforming American Education: Learning Powered by Technology*. Retrieved from [http://www.ed.gov/technology/netp-2010/executive-
summary](http://www.ed.gov/technology/netp-2010/executive-summary)

U.S. Department of Education. (2010, November 9). U.S. Department of Education Releases Finalized National Education Technology Plan. Retrieved from <http://www.ed.gov/news/press-releases/us-department-education-releases-finalized-national-education-technology-plan>

Virginia 4-H STEM Program Logic Model. (2011, February). Retrieved from <http://www.intra.ext.vt.edu/4h/documents/4hstem/Virginia4HSTEMLogicModel2014.pdf>

Virginia Department of Education. (2005, August). Improving School Attendance: A Resource Guide for Virginia Schools. Retrieved from http://www.doe.virginia.gov/support/prevention/dropout_truancy/improving_school_attendance.pdf

Wieman, C. (2007, September). Why Not Try a Scientific Approach to Science Education?. *Change: The Magazine of Higher Learning*, 9-15. Retrieved from http://www.cwsei.ubc.ca/SEI_research/files/Wieman-Change_Sept-Oct_2007.pdf

Appendix A: Pre-test and Post-test

Name: _____

For each of the following questions, circle the correct answer.

1. Magnets have
 - a. east and west poles
 - b. north, south, east, and west poles.
 - c. left and right poles
 - d. north and south poles
2. "Like" poles of a magnet
 - a. attract each other
 - b. repel each other
 - c. both attract and repel each other
3. When you rub a magnet against a needle, what happens?
 - a. the needle changes color
 - b. the needle is magnetized
 - c. the needle is energized
 - d. nothing happens to the needle
4. The needle in a compass lines up with:
 - a. the electric field around the earth
 - b. the magnetic field around the earth
 - c. the gravitational force around the earth
 - d. all of the above
5. What charge do electrons have?
 - a. positive
 - b. negative
 - c. neutral
6. Electricity can be defined as the flow of
 - a. Electrons
 - b. Protons
 - c. Neutrons
7. When we talk about "electricity" we are usually referring to
 - a. static electricity
 - b. current electricity
 - c. neutron electricity
 - d. proton electricity
8. All materials allow electrons (electricity) to flow.
 - a. True
 - b. False
9. Which of the following would not be a good conductor of electricity?
 - a. copper
 - b. aluminum
 - c. wood
 - d. metal
10. Which of the following would not be a good insulator of electricity?
 - a. rubber
 - b. metal pipe
 - c. plastic
 - d. glass
11. In a series circuit the electrons:
 - a. have only one path to follow
 - b. have more than one path to follow
 - c. only flow if it is an open circuit
12. In a parallel circuit the electrons:
 - a. have only one path to follow
 - b. have more than one path to follow
 - c. only flow if it is an open circuit

As a result of my experience in this 4-H program...	Yes	No
I can do an experiment to answer a question	<input type="radio"/>	<input type="radio"/>
I can tell others how to do an experiment	<input type="radio"/>	<input type="radio"/>
I can explain why things happen in an experiment	<input type="radio"/>	<input type="radio"/>

Appendix B: Virginia 4-H Electricity School

Enrichment Curriculum

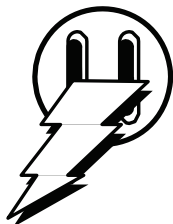

Acknowledgments:

A special thank-you to the following individuals for their vision, hard work and dedication in the design, development, and implementation of the Virginia 4-H In-School and School Enrichment Curriculum.

Science, Engineering, and Technology Curriculum Committee

Virginia Power Review Committee

Kathleen Jamison — Virginia Tech

Linda Burcham — Virginia Tech Tim

FisherPoff — Virginia Tech Elizabeth

Guinn — Virginia Tech

Revised 2009

Publication 388-800

Virginia Cooperative Extension



40

ELECTRICITY

Introduction

Lesson 1

Magnetic Attractions

Lesson 2

The Magnetic Field Around the Earth

Lesson 3

Static Electricity

Lesson 4

Current Electricity and Circuit Building

Lesson 5

Conductors and Insulators

Lesson 6

Author: Lori Marsh

Virginia Cooperative Extension programs and employment are open to all, regardless of race, color, religion, sex, age, veteran status, national origin, disability, or political affiliation. An equal opportunity/affirmative action employer. Issued in furtherance of Cooperative Extension work, Virginia Polytechnic Institute and State University, Virginia State University, and the U.S. Department of Agriculture cooperating. Rick D. Rudd, Interim Director, Virginia Cooperative Extension, Virginia Tech, Blacksburg; Wondi Mersie, Interim Administrator, 1890 Extension Program, Virginia State, Petersburg.

ELECTRIC ENERGY

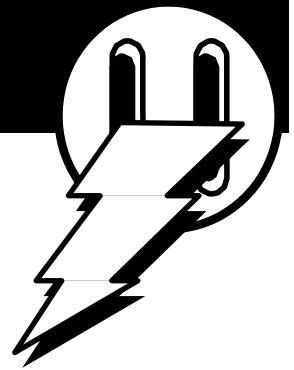

Introduction

The following lesson plans are designed to satisfy Virginia Science Standard of Learning 4.3. In addition, they support several of the goals in science SOL 4.1. Specifically, Science SOL 4.3 states:

The student will investigate and understand the characteristics of electricity. Key concepts include:

- a) conductors and insulators;
- b) basic circuits (open/closed, parallel/series);
- c) static electricity;
- d) the ability of electrical energy to be transformed into heat, light, and mechanical energy;
- e) simple electromagnets and magnetism; and
- f) historical contributions in understanding electricity.

The portions of Science SOL 4.1 that this curriculum supports are the following:

The student will plan and conduct investigations in which:

- distinctions are made among observations, conclusions, inferences, and predictions;
- hypotheses are formulated based on cause-and-effect relationships;
- variables that must be held constant in an experimental situation are defined;
- data are displayed using bar and basic line graphs;
- numerical data that are contradictory or unusual in experimental results are recognized; and predictions are made based on data from picture graphs, bar graphs, and basic line graphs.

Science SOL

4.1 & 4.3

ELECTRIC ENERGY

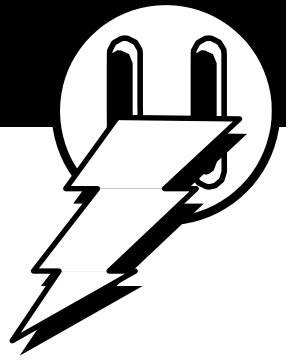

■ Format

Each Lesson contains both information for the teacher and copy-ready Activity Sheets and Youth Evaluation forms. The teacher section begins by identifying both a life-skill objective and the connection to the SOLs. An estimate of the time required to conduct the lesson and a supply list are provided. A Background Information section prepares the teacher to present the material. The Procedure section describes how to conduct the activity. This is followed by a Answers to the Youth Activity Sheet, which discusses the questions/answers presented to the students by the activity. The Evaluation section contains the questions presented to the students on the Student Evaluation form, along with the answers.

■ Resources

Electric Kit. This kit contains most of the supplies required to conduct these lessons. Most 4-H offices in Virginia have a kit that can be borrowed. Please call your local Virginia Cooperative Extension office to arrange to use the kit.

Science SOL

4.1 & 4.3

Lesson 1—Magnetic Attractions

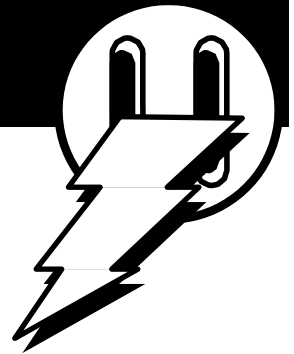

Life Skill Objective-Learning through Observation

Connections to the Standards of Learning

Science SOL 4.3 (e) states that students will investigate and understand simple electromagnets and magnetism.

Time Required - 50 minutes

Supply List

- Bar magnets with marked poles, two per group
- Bar magnet with unmarked poles, one per group
- Bowl with water in it
- Several metal paper clips
- Various materials that students can test for magnetic attraction (paper, plastic, wood, metal, etc.)
- Pencils
- Youth Activity Sheet

Background Information (For Group Discussion)

The goal is for youth to “investigate and understand magnets.” There are several concepts and characteristics that should be understood:

- A magnetic field surrounds all magnets;
- A magnetic field surrounds the earth;
- A magnetic field is strongest at the poles and weaker as the distance from the poles increases;
- A magnet field is invisible, but we can see the effect a magnetic field has on metal objects;
- A magnetic field will pass through materials such as glass, plastic,

Science SOL
4.1 & 4.3

Lesson 1 — Magnetic Attractions

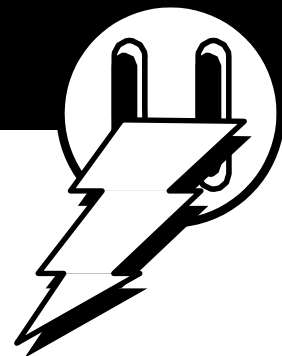

- The poles of a magnet are classified as North and South;
- Like poles repel and opposite poles attract each other.
- Magnets will attract metal objects that contain iron or nickel, but have no effect on other objects. NOTE: A nickel (five cent piece) does not contain the metal nickel and is not attracted by a magnet.

Magnetism is a naturally occurring force that acts on certain metals. Magnets radiate a force field that we call a magnetic field. The earth has a magnetic field around it. Another example of a force field is the force generated by the earth that we call gravity or the gravitational force field.

Hold up a magnet for the class and ask if they can see the magnetic field. Next, ask how we know that a magnetic field exists. Even though a magnetic field is invisible, it is possible to observe the effect of a magnetic field on iron filings. One way to do this is to place the magnet on an overhead projector, lay a blank transparency over the magnet, and lightly sprinkle iron filings over the transparency. The iron filings will align with the magnetic field. Another way to visualize the magnetic field is with the magnetic field demonstrator that is included in the 4-H Electric Energy Kit.

Magnets are said to have a north and a south pole. Scientists named the north pole of a magnet to be the part of the magnet that points toward the magnetic north pole of the earth. The south pole of the magnet is the pole opposite the north pole, or the pole that points towards the magnetic south pole of the earth. THIS IS A LITTLE TRICKY! A north pole of one magnet will attract the south pole of another magnet. Two similar poles will repel or push away from each other. However, the north pole of a magnet will point or be attracted to the north pole of the earth because that is the convention that scientists chose-the north pole of a magnet is the NORTH SEEKING pole, that is, the pole that is attracted to the north pole of the earth.

In this activity youth explore the properties of magnets. In the next activity, they will explore the response of magnets to the magnetic field around the earth.

Lesson 1 — Magnetic Attractions

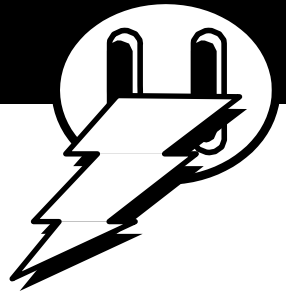

■ Procedure (Conducting the Activity)

Divide the class into groups and give each group two marked bar magnets and one unmarked bar magnet, a bowl with a small amount of water in it, a few metal paper clips, and a Youth Activity Sheet. They should also have access to other materials to determine which ones are attracted to the magnets. Such things as paper, pencils (wood), pens (plastic), etc are fine.

Have the students complete the activities outlined on the Youth Activity Sheet. Once they have had time to explore and complete the activities discuss the results with the class.

■ Answers to Youth Activity Sheet

1. The students should discover that opposite poles attract and like poles repel.
2. Based on the knowledge that opposite poles attract, students can use the marked bar magnet to determine the poles of the unmarked one. For example, the pole of the unmarked magnet that is attracted to the N pole of the marked magnet must be a south pole.
3. One way to check their determination of N and S poles on the unmarked magnet would be to compare with another group. If two groups bring what they determined to be N poles together, and they repel each other, that is an indication that they marked them correctly.
4. Magnets only attract materials with iron or nickel in them. Please note that the nickel (five cent piece) does not contain the metal nickel, and is not attracted by a magnet.
5. A magnetic field is strongest at the poles and weakest at the greatest distance from the poles (in the center of the bar).
6. A magnetic field can pass through materials such as air, water, paper, plastic, etc. The thickness of material that the magnetic field will pass through depends on the field strength. Since a compass works inside of buildings, the earth's magnetic field is passing through the building materials!

Science SOL
4.1 & 4.3

Lesson 1 — Magnetic Attractions

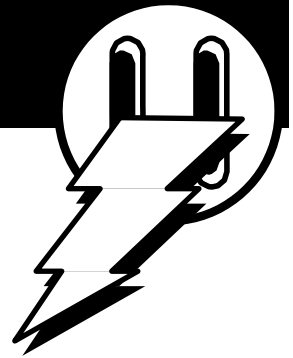

Evaluation (Answer Sheet)

Ask the students to write a short story with the ending “it just goes to show that likes repel” or “it just goes to show that opposites attract!”

For each of the following questions, mark the correct answer.

1. A magnetic field can be thought of as
 - something unnatural
 - a force field
 - something seen
2. Magnets have
 - east and west poles
 - north, south, east, and west poles.
 - left and right poles
 - north and south poles
3. “Like” poles of a magnet
 - attract each other
 - repel each other
 - both attract and repel each other
4. The north pole of a magnet is attracted to a certain part of the earth. That part is
 - London, England
 - the south pole
 - the north pole
 - Washington, D.C.
5. Magnets are attracted to
 - water
 - certain types of metal
 - wood
 - sunlight

Lesson 2 - The Magnetic Field Around the Earth

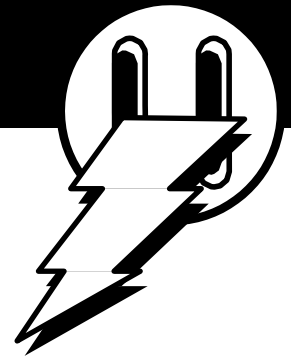

Life Skill Objective—Learning through Observation

Connection to Standards of Learning

Science SOL 4.3 (e) states that students will investigate and understand simple electromagnets and magnetism.

Time Required—30 minutes

Supply List

One set of the following for each group. Groups no bigger than three are recommended:

- bowl with small amount of water in it
- large needle
- a bar magnet with the poles marked (use magnets from previous exercise)
- styrofoam disk, about 1 inch in diameter, cut from a disposable plate, fast food clam shell, etc.
- Youth Activity Sheet

Background Information (For Group Discussion)

A magnetic field surrounds the earth. This magnetic field has two poles—a north and a south. Just as opposite poles of a magnet will be attracted to each other, a magnet that is allowed to turn freely will be attracted to the magnetic poles of the earth. This is the principle that a compass uses to point north. The needle of a compass is a magnet, and the needle is allowed to turn freely. It will align itself with the magnetic poles of the earth. The magnetic poles of the earth are close to the geographical poles, but not in exactly the same location. This means that a compass points to the magnetic pole, but not true north/south. To navigate with a compass, it is necessary to correct the compass reading to true north/south. The exact correction depends on where you are relative to the poles. In Virginia, the correction is very small—approximately 2 degrees.

Science SOL
4.1 & 4.3

Lesson 2 - The Magnetic Field Around the Earth

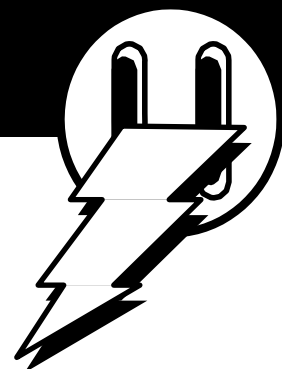

Today you will build a compass and observe how it responds to the earth's magnetic field.

■ Procedure (Conducting the Activity):

Divide the class into working groups and give each group one set of materials. You may want to give each group one activity sheet, or you may choose to give one sheet to each child. Instruct the groups to follow the directions provided to build a compass. You may wish to use class discussion to answer the questions on the Youth Activity Sheets.

Note to the Instructor: Once the needle is magnetized and put in the bowl to float, it should point to magnetic north/south. However, if there is a permanent magnet somewhere close to the bowl, the magnet field from the magnet may be stronger than the earth's magnetic field, and it will attract the needle. Caution students not to leave the permanent magnet near their bowl when they are trying to use it as a compass.

■ Answers to Youth Activity Sheet:

1. The needle points north/south because it has been magnetized and a magnet will respond (be attracted/repelled) to the magnetic field of the earth.
2. You really can't tell which direction is north and which is south from looking at the needle. You need some other way of knowing, such as knowing where the sun rises and sets, or by using a magnet with known poles. The end of the needle that points north will be attracted to the south pole of a magnet and repelled from the north pole. Once you know which way is north, you can mark that end of the needle for future reference. If you look at a real compass, you will see that one end is colored or shaped like an arrow. The colored end (or the arrow end) is the north seeking pole of the magnetic needle and it points north.
3. If all the needles in the bowls are pointing the same way, it makes sense to think that "something" is causing it—it isn't just a random occurrence. With only one needle in a bowl, there is no way to be sure it didn't point north by chance alone.
4. Scientists conduct an experiment more than once (use repeated trials) to make sure something is repeatable—that it will occur the same way every time. This provides evidence that something is happening for a reason, not just by chance.

Science SOL
4.1 & 4.3

Lesson 2 - The Magnetic Field Around the Earth

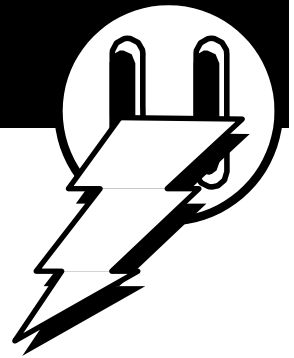

Evaluation (Answer Sheet)

Ask your students to write a paragraph that explains how a compass works. A compass works because there is a magnetic field around the earth and the needle of a compass is a magnet. The compass needle is attracted to the magnetic poles of the earth, so it points north/south.

For each of the following questions, mark the correct answer.

1. When you rub a magnet against a needle, what happens?
 - the needle changes color
 - the needle is magnetized
 - the needle is energized
 - nothing happens to the needle
2. The needle in a compass points:
 - north/south
 - east/west
 - it depends on where you are when you use it
 - toward the nearest electric outlet
3. The needle in a compass lines up with:
 - the electric field around the earth
 - the magnetic field around the earth
 - the gravitational force around the earth
 - all of the above

Lesson 3—Static Electricity

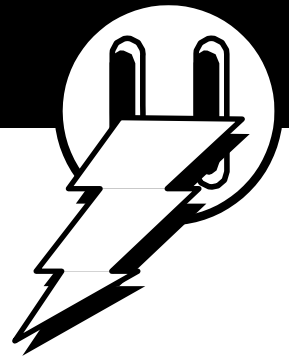

Life Skill Objective—Learning through Observation

Connection to Standards of Learning

Science SOL 4.3 (c) states that students will investigate and understand the characteristics of electricity including static electricity.

Time Required—35 minutes

Supply List

- balloons (two per cooperative learning group)
- about 2 feet of string or thread per group
- 1/4 sheet of notebook paper per group
- a small piece of cloth, preferably wool
- a copy of the Youth Activity Sheet for each student or each group

Background Information (For Group Discussion)

All matter is composed of atoms. Even though we can't see the atom, scientists have discovered many interesting things related to the atom and electricity.

An atom has both positive and negative charges, which are in balance. The center of an atom, called the nucleus, contains neutrons and protons. Neutrons have no electrical charge—they are neutral. Protons have a positive charge.

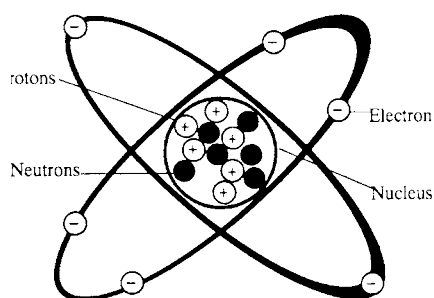

A Carbon Atom

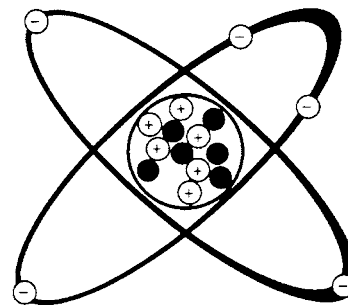

Positive Ion

Science SOL
4.1 & 4.3

Lesson 3—Static Electricity

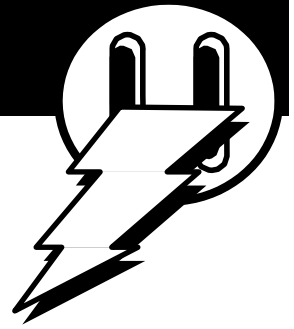

Moving in an orbit around the nucleus are electrons. Electrons have a negative charge and are free to move about the nucleus. The movement of electrons makes it possible for atoms to share electrons and is what binds matter together.

The electrons farthest from the nucleus are easiest to move. When it is cold and dry and you rub your feet across a carpet, you can rub electrons off the carpet and collect them on your body. This collection of electrons creates a negative charge relative to the things around you—it is called static electricity. After you collect electrons, you can cause an electrical discharge by touching another object. This is what happens when you get a small shock after running across carpet on a cold day.

You saw that with magnets opposite poles attracted each other and like poles repelled each other. This concept applies to electrical charges too. A negative charge is attracted to a positive charge but two negative charges will repel or push away from each other. Now you will have a chance to “collect electrons” and build some negative charges.

■ Procedure (Conducting the Activity)

After discussing the concept of an atom orbited by electrons and introducing the idea that electrons can be “collected,” thus resulting in a negative charge, break the class into working groups. Groups of three are probably best. Give each group two balloons, two pieces of string, and a piece of paper. Note: These activities work best in the winter, when the air is dry. Very humid conditions make the collection of a static charge difficult.

Distribute copies of the Youth Activity Sheets to each student (or each group). Ask them to read the instructions, conduct the experiments, and record their results. You may want each child to record results for themselves, or you may ask each group to select a group recorder. After everyone has conducted the experiments, discuss the results with the class.

■ Additional Activity (Optional)

Here is an additional activity that you may want your students to conduct at home.

Find a plastic comb and something made out of wool. Charge the comb with static electricity by rubbing it several times on the wool cloth. Turn on the faucet in a bathroom or kitchen to make a SMALL stream of

Science SOL
4.1 & 4.3

Lesson 3—Static Electricity

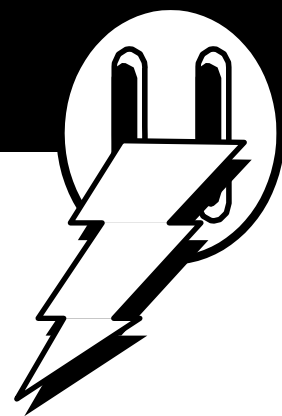

water. Hold the comb very near the stream of water BUT DO NOT GET IT IN THE WATER. What happens?

Next, put the comb in the stream of water for a few seconds. After getting the comb wet, put it back close to the stream, but not in it. Does the comb still attract the water? Why or why not?

Answers to Youth Activity Sheet:

1. The team member's hair "stands up" or is attracted to the balloon because the balloon has a charge because it has exchanged electrons with the cloth. The balloon and cloth will have opposite charges. It's not really obvious which has a positive charge and which has a negative charge.
2. The pieces of paper are attracted to the balloon because it carries a static charge.
3. When the two balloons are brought close together, they will repel each other because they both have the same charge and "likes" repel.

The take home exercise: Rubbing the comb with wool put a static charge on it, which attracted the stream of water. Putting the comb in the water allowed the water to carry away the charge, leaving the comb uncharged. After the comb lost its charge, it did not attract the stream of water.

Evaluation (Answer Sheet)

Static electricity is a collection of electrons.

Two balloons with a static charge will attract or repel each other? repel

For each of the following questions, mark the correct answer.

1. All matter is composed of:

- fiber
- cells
- atoms
- minerals

Science SOL
4.1 & 4.3

Lesson 3—Static Electricity

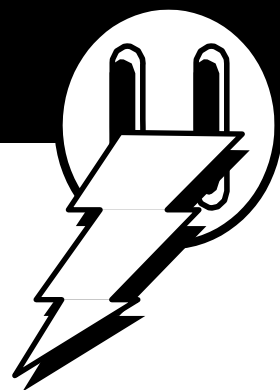

2. Two types of charges of an atom are:

- positive and negative.
- up and down.
- left and right.
- neutral and positive.

3. Moving in an orbit around an atom's nucleus are:

- electrons
- protons
- neutrons

4. When it is cold and dry and you rub your feet across a carpet, you can rub _____ off the carpet and collect them on your body.

- electrons
- protons
- atoms
- neutrons

5. What charge do electrons have?

- positive
- negative
- neutral

Lesson 4 — Current Electricity & Circuit Building

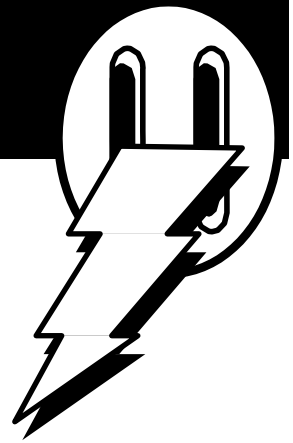

Life Skill Objective—Learning through Observation

Connection to Standards of Learning

Science SOL 4.3 (a and b) states that students will investigate and understand basic circuits (open/closed, parallel/series) and conductors and insulators.

Time Required—One hour

Supply List

For each group:

- two D-cell battery holders
- two D-cell batteries
- two flashlight bulbs (1.5 or 3 volt)
- two light bulb holders
- six pieces of insulated wire (22 to 26 gauge, solid core) with the ends stripped about 1/2 inch.
- Youth Activity Sheet

Background Information (For Group Discussion)

Static electricity is one form of electricity, but it is not very useful—we cannot control it to do useful work for us. Another form of electricity is current electricity. Whenever we talk about electricity, we are referring to current electricity.

Electricity is the flow of electrons. What does it take to make electrons flow? It takes two things—something to push the electrons and a path for the electrons to travel. The force that pushes electrons is called voltage and is measured in volts. The flow of electrons is called current and is measured in amperes or just amps for short.

Science SOL
4.1 & 4.3

Lesson 4 — Current Electricity & Circuit Building

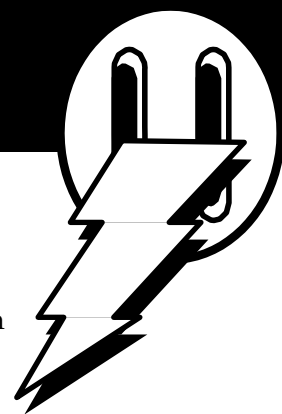

A good analogy to understand electricity is to compare it to the flow of water. Voltage, the force that pushes electrons, is analogous to water pressure, the force that pushes water in pipes. Amperage, which is a measure of the rate of flow of electrons, is analogous to the rate of flow of water. We measure water pressure in pounds per square inch (psi); we measure electrical pressure in Volts. We measure the flow of water in gallons per minute (gpm); we measure the flow of electrons (electricity) in Amperage or Amps for short.

Another component of a water system is resistance. A good example of a variable resistance in a water “circuit” is a faucet. The more open the faucet, the less the resistance to the flow of water, and the more water that will flow. When the faucet is closed, the resistance to the flow of water is so high that no water can flow. In an electrical circuit, the components (light bulbs, toasters, hair dryers, etc.) each have an internal resistance. Switches have a very low resistance when they are closed (ON) and a very high resistance when they are open (OFF). For a given electrical pressure (voltage), the higher the resistance (measured in Ohms) in a circuit, the less electricity will flow.

If you build two circuits—one with one battery and one light bulb and a second with one battery and two light bulbs in series, you will see that the bulb in the circuit with only one bulb burns much brighter than the bulbs in the circuit with two bulbs. This is because the two-bulb circuit has twice the resistance to the flow of electricity—the amperage flowing in the two-bulb circuit is only half of the amount flowing in the one-bulb circuit. A two-bulb circuit (compared to a one-bulb circuit) is like a half open faucet compared to a completely open faucet—two bulbs have twice the resistance of one and a half-closed faucet has more resistance than a completely open faucet.

If you build one circuit with one battery and one bulb and a second circuit with two batteries and one bulb, you will see that the bulb in the circuit with two batteries is brighter than the one with only one battery. This is because the voltage (electrical pressure) is greater with two batteries. This would be analogous to observing the flow of water from your faucet at some faucet setting, and then increasing the water pressure in your house and observing the flow from the faucet without changing the setting on the faucet.

Note: The path that electrons follow through a light bulb is not obvious, because you cannot see the connections from the filament to the filament supports. If you could cut open a light bulb (Figure 1), you would find that one end of the filament support connects to the metal case that screws in to the light bulb receptacle, and the other end of the filament

Lesson 4 — Current Electricity & Circuit Building

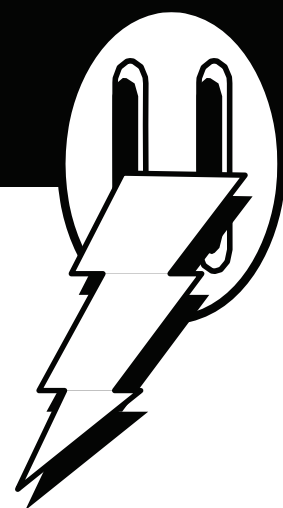

support connects to the nub end of the bulb. Note that there is a ceramic ring (this is an insulator) that separates the metal case from the metal nub end. So, electrons flow from the nub end, through the filament support, to the filament, to the other filament support, to the metal case. One of the electrical leads on a bulb holder connects to the metal case and the other to the nub end.

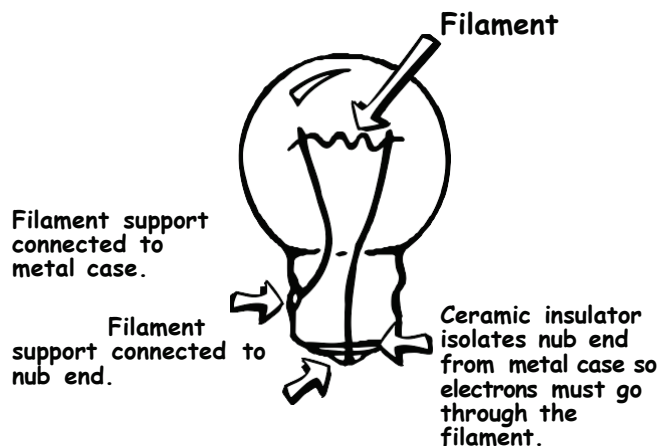

Figure 1. Schematic showing the path electrons follow through a light bulb.

■ Procedure (Conducting the Activity)

Explain briefly to the class the concept of static versus current electricity. Tell them that they are going to explore current electricity. It is important to discuss electrical safety with your students. You might say something like the following:

I'm sure you have been told that electricity is dangerous—that it can kill you. This is true. However, the 1.5 volt batteries that we will be working with in class cannot hurt you. They do not have enough “push” or voltage to make current flow through your body. So do not worry that any of the exercises that you do in class are dangerous—they are not. However, the 120 volts at an electrical outlet does have enough push to kill you. You should never experiment with the wiring in your home without the help and supervision of an adult who knows what they are doing.

Explain the concept of an electrical circuit by saying that it contains something to push electrons (in this case—a battery), a path for the electrons to flow along (in this case—wire) and something for the electrons to do (in this case—light a bulb). If the path for electrons to follow is complete (makes a circle), then it is called a closed circuit, electrons will flow, and the light will be on. If the path is not complete, then it is called an open circuit, electricity will not flow, and the light will not be on. Explain to the class the analogy between water pressure and electrical pressure, water flow and electron flow, and resistance in a faucet and resistance in an electrical circuit.

Science SOL
4.1 & 4.3

Lesson 4 — Current Electricity & Circuit Building

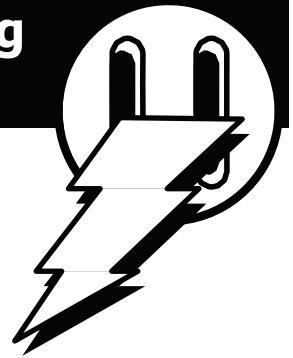

Divide the class into working groups and give each group a battery, a light bulb and a piece of wire (about 6 inches long). Note: Depending on the students, you may want to strip about one-half inch of insulation off each end of the wire or you may want to give them wire with the insulation left on and make them figure out that it needs to be stripped. They may have no basis for knowing about insulation on wire—this concept is introduced in the next lesson. Ask them to work together to make the bulb light. There are four ways to accomplish this (Figure 2). Note that all four ways involve connecting the screw-in bulb case to one side of the battery and the nub end to the other side of the battery.

Figure 2

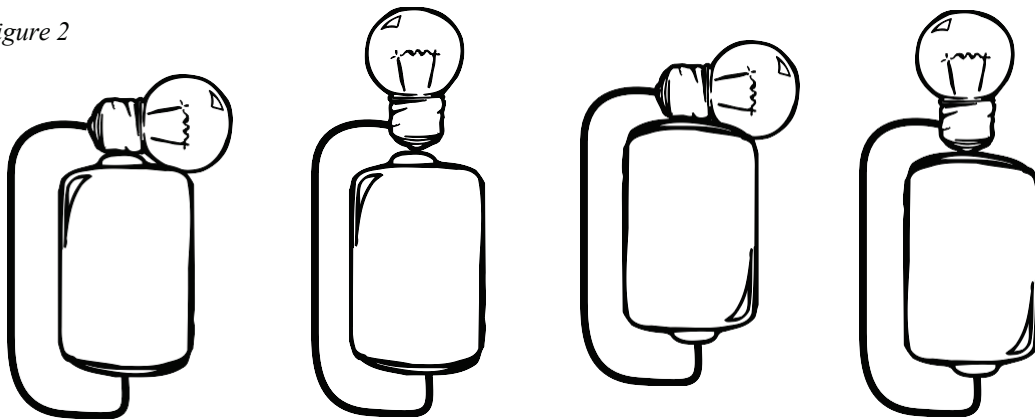

Figure 2. Possible ways to light a light bulb with a battery, bulb and single piece of wire. Note: the third and fourth approach are identical to the first and second, except the battery is turned over (bulb sitting on opposite battery terminal). In every case, one terminal of the battery is touching the screw-in case of the bulb (either directly or connected by a wire) and the other terminal of the battery is touching the nub end of the bulb.

After the students have accomplished this task, distribute holders for batteries and bulbs, an additional battery, bulbs, and wires to each group. Give each group (or each student) a Youth Activity Sheet and ask them to follow the instructions given on the activity sheets. You may have to demonstrate to students how to put the batteries in the battery holders and how to connect wires to the clips on the battery and bulb holders.

Answers to Youth Activity Sheet

1. Closed, on
4. Open, off

2. Open, off
5. Open, off

3. Closed, on

Science SOL
4.1 & 4.3

Lesson 4 — Current Electricity & Circuit Building

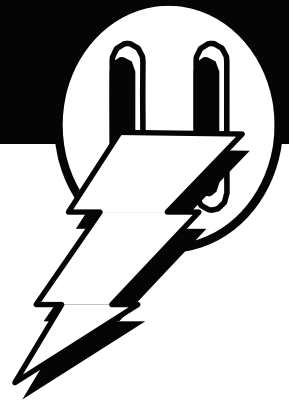

Evaluation (Answer Sheet)

1. An open circuit will allow electrons to flow (true or false).
2. If a light is on, the circuit is closed (open or closed).
3. Mark the following, as open or closed.

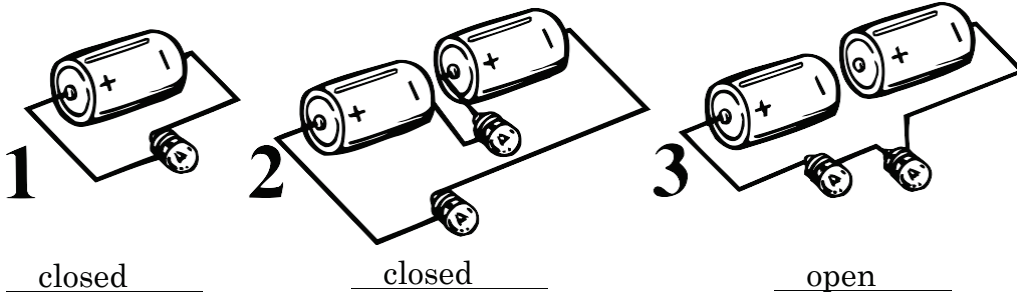

For each of the following questions, circle the correct answer.

4. When we talk about “electricity” we are usually referring to
 - static electricity
 - current electricity
 - neutron electricity
 - proton electricity
5. Electricity can be defined as the flow of
 - neutrons
 - protons
 - electrons
 - water
6. For electricity to flow, two things are necessary-something to push electrons and a path for them to follow
 - True
 - False

Science SOL
4.1 & 4.3

Lesson 4 — Current Electricity & Circuit Building

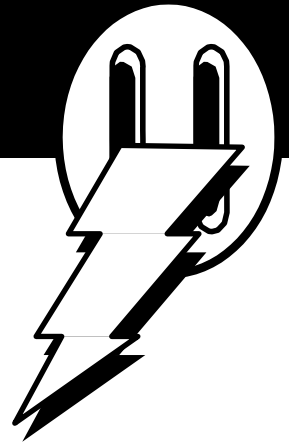

7. The force that pushes electrons is called:
- voltage
 - current
 - magnetism
 - gravity
8. The flow of electrons is called:
- voltage
 - magnetism
 - current
 - gravity
9. The flow of electrons is measured in units called:
- amperes
 - volts
 - ohms
 - millimeters
10. The resistance to the flow of electrons is measured in:
- volts
 - amps
 - ohms
 - gallons



Lesson 5—Conductors and Insulators

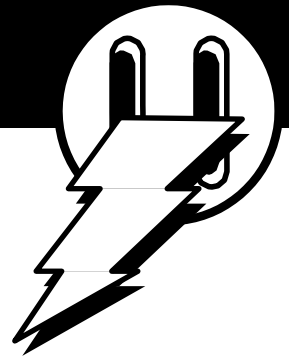

Life Skill Objective—Learning through Observation

Connection to Standards of Learning

Science SOL 4.3 (a) states that the student will investigate and understand conductors and insulators.

Time Required—45 minutes

Supply List:

For each group:

- 1 index card
- 1 pair of scissors
- 1 metal paper clip
- 2 metal paper fasteners/brads (at least 1/4 inch; 1/2 inch are OK too)
- 2 D-cell batteries
- 2 D-cell battery holders
- 1 flashlight bulb (1.5 or 3 volt)
- 1 light bulb holder
- 6 pieces of insulated wire (22 to 26 gauge, solid core) with the ends stripped about 1/2 inch
- Materials for testing to determine if they are insulators or conductors. Possible materials include: wood (a pencil); plastic (a pen); paper, rubber (rubber bands), metal (aluminum foil, etc.)
- Youth Activity Sheets

Science SOL
4.1 & 4.3

Lesson 5 — Conductors and Insulators

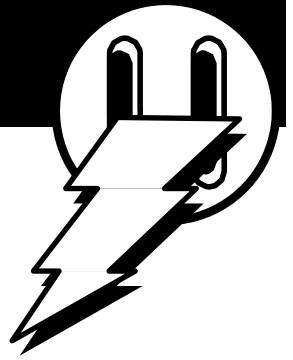

■ Background (For Group Discussion)

An electrical circuit requires three things: a path for electricity, something to push the electrons—a voltage source, and some kind of appliance or device for the electricity to power. Generally, a circuit also contains a switch, which allows the circuit to be opened and closed easily, turning the flow of electricity (and therefore the appliance) on or off.

Some materials allow electrons to flow and are called conductors. They have a low resistance to the flow of electrons. Other materials have a very high resistance to the flow of electrons and are called insulators.

Metals have low resistance to electricity flow and make good conductors. That is why electrical wiring, which is designed to provide a path for electricity to flow, is made out of copper or aluminum. Plastic, glass and rubber are good electric insulators. Electricians and others who work around electricity wear rubber protective clothing to avoid being shocked.

■ Procedure (Conducting the Activity)

Tell the students that they are going to make a switch that they will be using for other activities. Distribute to each group an index card, two metal paper fasteners (brads), a metal paper clip and two pieces of solid core wire (about 6 inches long, with 1/2 inch of insulation stripped from each end of the wires), and the Youth Activity Sheet.

After the switches are made (this should take no more than 10 minutes), explain to the students the concept of insulators (that do not allow electrons to flow) and conductors (that do allow electrons to flow).

Tell the students that they are going to use their switch to make a conductivity tester and use it to decide if a material is an insulator or conductor. Distribute materials to be tested.

Have students list the materials they have in the first column of their data table. Next, have them guess or predict if the material is a conductor or insulator. Finally, have them test their prediction by opening their switch and placing the material to be tested across the metal paper fasteners on the switch. In other words, have them use the material to be tested in place of the paper clip. Make sure the material is really touching both metal paper fasteners. If the light comes on, then the material is allowing electricity to flow. That means the material is a conductor. If the light does not come on (and they are making a good connection between the material they are testing and the metal paper

Lesson 5—Conductors and Insulators

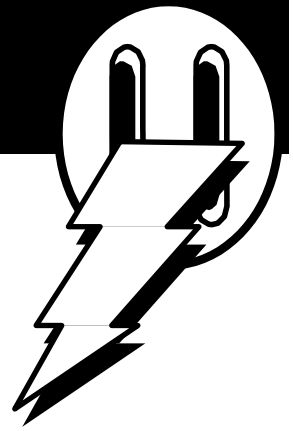

fasteners), then the material will not allow electricity to flow, and it is an insulator. Have the youth record the results of each test in the data table provided.

Answers to Youth Activity Sheet

1. By using the conductivity tester they built, students should discover that metal objects conduct electricity (allow electrons to flow), while other objects (paper, plastic, glass, air) are insulators and do not allow electricity to flow.
2. Air is an insulator. Students should know this because in the previous exercise, when the circuit was “open”, i.e., part of the path from one terminal of the battery back to the other terminal consisted of air, the light bulb was not on.
3. Electricians wear clothing that insulates them from electricity because they do not want to be part of an electrical circuit. People who work with high-voltage electricity wear rubber gloves and rubber soled shoes. Rubber is a good insulator.
4. Extension cords are covered with rubber or plastic because both are good insulators. Since the cord is insulated, it doesn't matter what it touches, because anything it touches will not be “exposed” to electricity. If an extension cord were made covered with a conductor, i.e., metal, and it touched any other conducting material, then the material it touched would provide a path for electricity to flow. The electricity would then be taking an unintended path. This is called a SHORT circuit or just a “Short”.

Evaluation (Answer Sheet)

For each of the following questions, mark the correct answer.

1. For each material, mark I for insulator or C for conductor.

	I	C	I	C
Plastic	<input checked="" type="radio"/>	<input type="radio"/>		
Wood	<input checked="" type="radio"/>	<input type="radio"/>	Rubber	<input checked="" type="radio"/> <input type="radio"/>
Copper	<input type="radio"/>	<input checked="" type="radio"/>	Glass	<input checked="" type="radio"/> <input type="radio"/>
Metal	<input type="radio"/>	<input checked="" type="radio"/>	Air	<input checked="" type="radio"/> <input type="radio"/>

Lesson 5—Conductors and Insulators

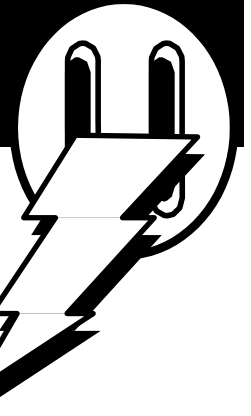

2. The purpose of an electric switch is
- to measure amounts of electricity
 - to redirect the flow of electricity
 - to turn the flow of electricity off and on
 - Don't know
3. All materials allow electrons (electricity) to flow.
- True
 - False
4. Materials called conductors have _____ resistance to the flow of electrons (electricity).
- Low
 - High
 - Medium
5. Materials called insulators have _____ resistance to the flow of electrons (electricity).
- Low
 - High
 - Medium
6. Which of the following would not be a good conductor of electricity?
- copper
 - aluminum
 - wood
 - metal
7. Which of the following would not be a good insulator of electricity?
- rubber
 - metal pipe
 - plastic
 - glass

Lesson 6 -Circuit Building-Series and Parallel Circuits

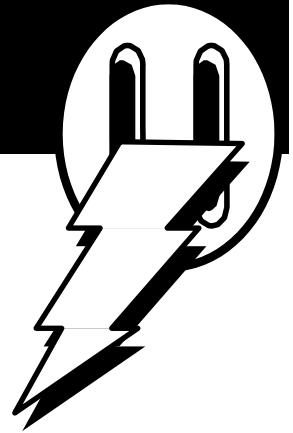

Life Skill Objective-Learning through Observation

Connections to Standards of Learning

Science SOL 4.3 (b) states that students will investigate and understand characteristics of basic circuits (open/closed, parallel/series).

Time Required-One hour

Supply List

For each group:

- One D-cell battery holder
- One D-cell battery
- Two flashlight bulbs (1.5 or 3 v)
- Two light bulb holders
- Four pieces of insulated wire (22 to 26 gauge, solid core) with ends stripped about 1/2 inch.
- Youth Activity Sheet

Background (For group discussion)

There are two basic types of circuits—one is called a series circuit and the other is called a parallel circuit. In a series circuit, there is only one path for electrons to follow from one terminal of the battery back to the other terminal. In a parallel circuit, there is more than one path that the electrons can follow in their journey from the negative terminal back to the positive one. To decide how many paths a circuit has, you can do the following:

1. Start at the negative terminal of a battery in the circuit.
2. With your index finger, trace the path that the electrons will follow (along a wire, or through a component such as a light bulb or buzzer etc) by moving your finger along the path. Remember, any conductor can be a path for electrons, but an insulator (such as air, glass, rub-

Science SOL
4.1 & 4.3

Lesson 6 -Circuit Building-Series and Parallel Circuits

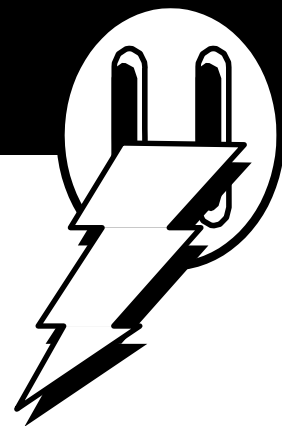

ber, or plastic) will not provide a path for electrons. Also, remember that a battery is a path for electrons. If there is not a complete path, the circuit is open, electrons will not flow, and the appliance will not be on.

3. As you trace the path, check and see if there is more than one way the electrons can flow in the circuit-there is more than one way that electrons can flow if there is more than one wire connected together at a single point.

Series circuits behave differently from parallel circuits. If two light bulbs are wired in series, then the electrons must flow through one bulb to get to the next one (see Figure 1). This means if the first bulb burns out (and becomes an open circuit!) then the second bulb will not glow, because the electrons cannot reach it. Also, when two light bulbs are in series, their resistances add, so the total resistance in the circuit is increased and the amount of electricity flowing is reduced (just like closing down on a faucet increases resistance and decreases the flow of water). With less electricity flowing, the bulbs will be less bright.

In a parallel circuit, each bulb will have a path to the battery that can carry electrons, so if one bulb is removed from the circuit (or burns out), the other bulb will continue to burn because it still has a path for electrons (see Figure 2) to travel back to the battery. Also, each bulb will burn as brightly as if the other was not there. This is because the resistance to the flow of electrons is just one bulb's worth in each path, not the combined resistance of two bulbs.

A good analogy for thinking of series and parallel circuits is a bucket of water, with two faucets attached to it. Imagine that this is a magic bucket that always remains full, no matter how much water is running out of it.

If the water has more than one way to leave the bucket (two faucets open) then it is analogous to a parallel circuit. If there is only one way for water to leave the bucket (one faucet open), then it is analogous to a Series circuit. With the two-faucet/parallel circuit analogy, you can see that closing one faucet will have no effect on the other. Also, the rate of flow from each faucet when both are wide open would be the same as the rate of flow from one faucet wide open. This is why two bulbs in a parallel circuit each burn as brightly as one bulb in a series circuit.

So how can this analogy be used to describe two light bulbs in series? It is a bit of a stretch, but first remember that since we are talking about a series circuit, there must be only one way for water to leave the bucket, so think of one faucet. With one bulb, the faucet is open at some setting; when the second bulb is added, it is like forcing the water through a

Lesson 6 -Circuit Building-Series and Parallel Circuits

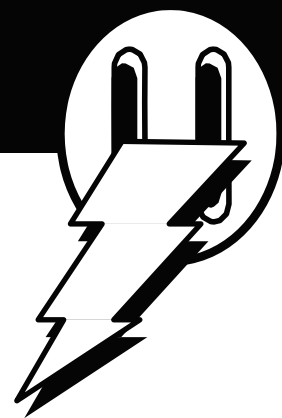

second restriction (more resistance), as if the faucet were partially shut

down. The effect will be to reduce the flow of water out of the bucket.

Likewise in a series circuit, adding a second bulb in the same path (remember, a series circuit only has one path for electrons to follow) will

increase the resistance and therefore reduce the flow of electrons. The effect of reducing the flow of electrons on the light bulbs is to reduce the amount of light produced by the bulbs.

The bucket analogy can also be used to see the effect of increasing the voltage (adding more batteries) to the circuit. Remember, voltage is electrical pressure, so increasing the batteries (voltage) is like increasing the water pressure. This could be accomplished by increasing the height of the water column in the bucket. As the height of the water above the faucets increases, the water pressure on the faucets increases, and the flow of water from a given faucet opening (fixed resistance) will increase. Likewise as the number of batteries in a circuit increases, the electrical pressure (voltage) increases, and the flow of electrons (amperage) also increases for a given number of light bulbs (fixed resistance); thus the bulb(s) burn brighter.

Build the circuits shown in Figures 1 and 2 and make sure you can follow the path of the electrons before introducing this lesson to your students.

Looking at Figure 1: We think of electrons being repelled from the negative pole of the battery and being attracted to the positive pole. The path for electrons is through wire 1 to bulb 1, through the bulb to wire 2, through wire 2 to bulb 2, through bulb 2 to wire 3, and through wire 3 back to the battery. Note that removing either bulb from the circuit will eliminate the path for electrons, since air is an insulator and the electrons can't travel through the air (where the bulb was) to continue their journey back to the battery.

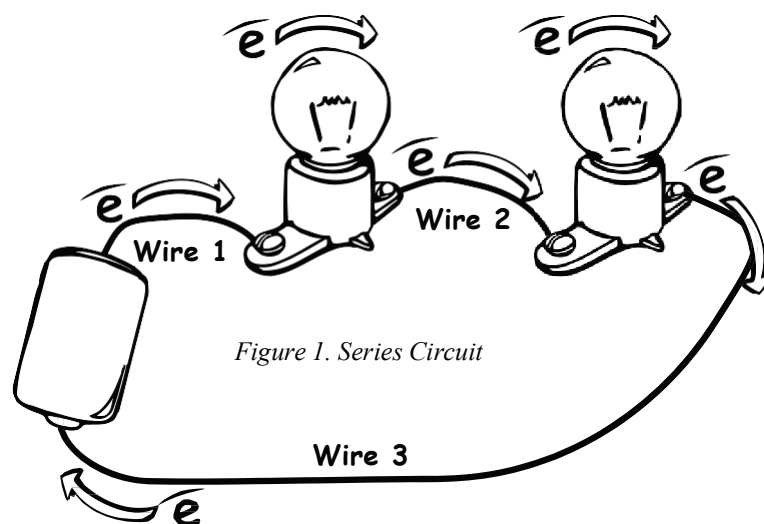
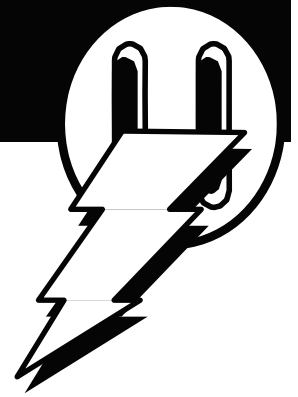

Figure 1. Series Circuit

Lesson 6 -Circuit Building-Series and Parallel Circuits



Looking at Figure 2:

Electrons travel through wire 1 to bulb 1. At this point, there are two possible paths back to the battery- either through bulb 1 and then wire 4 OR through wire 2, bulb 2, wire 3 and wire 4 back to the battery. Note that

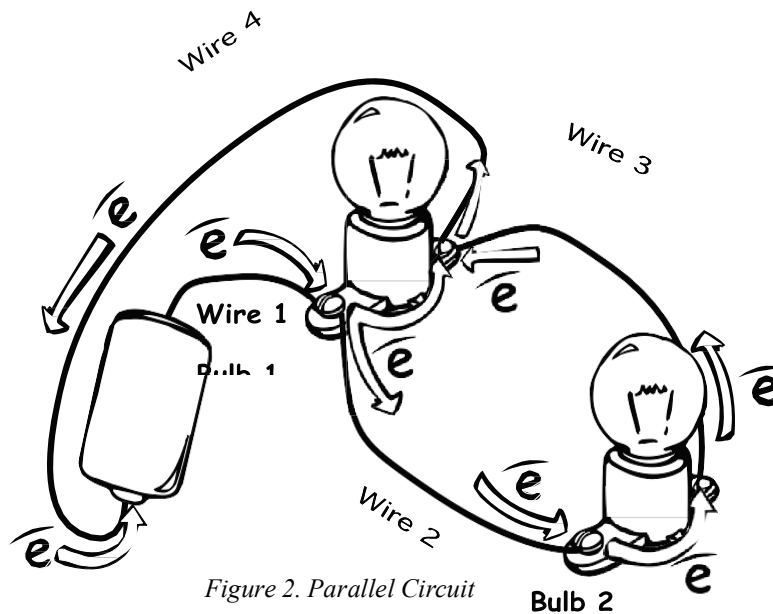

Figure 2. Parallel Circuit

with either path, the electrons must go through a light bulb to get back to the

battery. Why is this important? The amount of electrons that follow each path is inversely proportional to the resistance along the path-put more simply, a lot of electrons will take a path with little resistance, and very few electrons will take a path with a great deal of resistance. In this instance, the resistance in either path is the same (the added resistance due to longer wires is negligible!), so the same number of electrons will take each path. This means the two bulbs will be at the same brightness.

Try this experiment: Take the ends of wires 2 and 3 and disconnect them from bulb 2. (Note what happens to bulb 1.) Now, connect the ends of wires 2 and 3 together. What happens to bulb 1? In this case, there are two paths for electrons to follow back to the battery-the path through bulb 1 OR the path through wire 1 to wire 2 to wire 3 to wire 4 back to the battery. In one path, the light bulb represents high resistance compared to the resistance in the other path, which is just wire. The vast majority of electrons take the path with little resistance, so there are not enough electrons flowing through the light bulb to make it light.

Procedure (Conducting the Activity)

Organize your students into working groups. Explain to the students that they will be building series and parallel circuits and learning how each one behaves. Distribute the materials to each group and ask them to follow the directions on the Student Activity Sheet.

Science SOL 4.1
& 4.3

Lesson 6 -Circuit Building-Series and Parallel Circuits

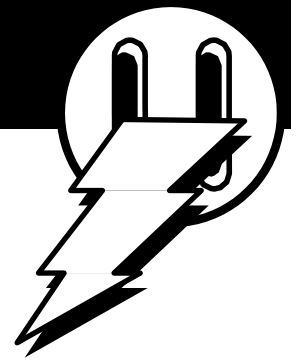

■ Answers to Youth Activity Sheet

On the Youth Activity Sheet, the students are asked to describe the path the electrons take in words. For the series circuit (the first activity), a suitable answer is: The electrons travel along the first wire to the bulb, through the first bulb to the second wire, through the second wire to the second bulb, through the second bulb to the third wire and through the third wire to the positive terminal of the battery.

When one bulb is unscrewed in the series circuit, the other bulb goes out because the missing bulb causes an open circuit and the electrons do not have a complete path to follow.

When they traced the path for electrons to follow, there was only ONE path for electrons to follow.

This type of circuit is called a **SERIES** circuit.

For the second circuit, a suitable description is:

The electrons travel along the first wire to the first bulb. When they get to the first bulb, some of the electrons go through the bulb, but some of the electrons go through the second wire to the second bulb. After the electrons go through the first bulb, they travel through the fourth wire back to the battery. The electrons that go through the second bulb travel through the third wire back to the first bulb, but instead of going through the first bulb, they follow the fourth wire back to the battery.

Was there ever a point when the electrons could go to more than one place (a branch in the circuit)? Yes. At bulb one, some of the electrons went through the bulb back to the battery, but some went on to the second bulb without going through the first bulb.

This is a **PARALLEL** circuit.

When one bulb is unscrewed, the other remains on, because it still has a complete path for electrons.



Lesson 6 – Circuit Building-Series and Parallel Circuits

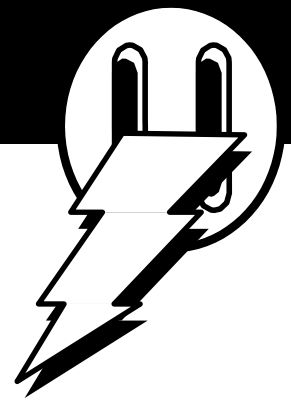

Evaluation (Answer Sheet)

- In a series circuit with two light bulbs, if one of the bulbs burns out, the other bulb will:
 - go out also
 - burn more brightly
 - not change at all burn
 - less brightly
- In a parallel circuit with two light bulbs, if one of the bulbs burns out, the other bulb will:
 - go out also
 - burn more brightly
 - not change at all
 - burn less brightly
- In a series circuit the electrons:
 - have only one path to follow
 - have more than one path to follow only flow if it is an open circuit
 - a and c are both correct answers
- In a parallel circuit the electrons: have only one path to follow
 - have more than one path to follow only flow if it is an open circuit
 - a and c are both correct answers
- The circuits in my house are wired in parallel because:
 - if they were in series, and I turned off one appliance, all the other appliances on the same circuit would go out too.
 - it takes less wire to make a parallel circuit
 - a parallel circuit is safer
 - they are wired in series, not parallel.

Science SOL
4.1 & 4.3

Lesson 7 — Electromagnets

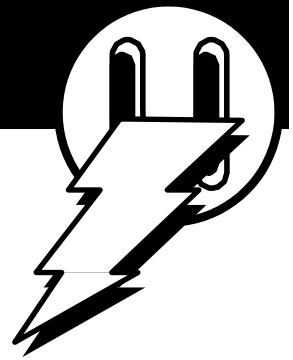

Life Skill Objective—Learning through Observation

Connection to Standards of Learning

Science SOL 4.3 (e) states that students will investigate and understand characteristics of electromagnets and magnetism.

Time Required—One hour

Supply List

- One set of the following for each working group:
- two D-Cell batteries
- two battery holders
- about 3 feet of insulated wire (20, 22, or 24 gauge is fine) with about 1/2 inch of insulation removed from each end
- one large nail (3 or 4 inches)
- several metal paper clips
- the switch from the previous lesson
- pencils
- Youth Activity Sheets

Background Information (For Group Discussion)

Whenever electricity flows, a magnetic field is present—this is a phenomenon that scientists have observed. No one knows why, any more than we know why there is gravity or why there are magnetic fields. You can demonstrate the fact that a magnetic field is present when electricity flows by building an electromagnet.

Explain to the class that they are going to work in groups to build an electromagnet and to conduct an experiment to see if the number of times they wrap the wire around the nail in the electromagnet will affect

Science SOL
4.1 & 4.3

Lesson 7 — Build an Electromagnet

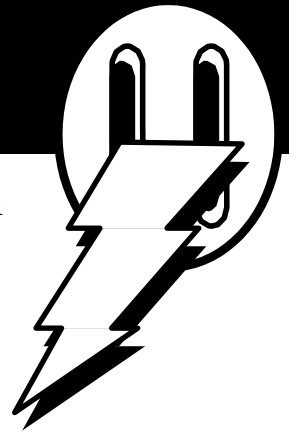

how strong the magnet is. Each group will collect one set of data and then share their data with the class. Each group will serve as one trial, and all the groups together will make a set of repeated trials.

Explain to the class that if they test 5 wraps and then 10 and then 15 and then 25, the batteries will be getting a little weaker with each test and they won't be sure if any differences they see are due to a difference in the number of wraps or a difference in battery strength. You might ask the class for ideas of how to solve this problem. Possible solutions include using fresh batteries for every test or using a 6-volt power supply instead of batteries (the power supply uses electricity and won't get weaker over time.) Another solution is to randomize the order in which the number of wraps are tested. That way, some groups will test high wrap numbers with fresh batteries, and some will test low wrap numbers with fresh batteries; the effect of battery freshness will be averaged out. Tell the groups that they will randomize the order in which they conduct their tests.

Procedure (Conducting the Activity)

Divide the class into groups and give each group a set of materials to build an electromagnet. You may want each group to complete one Youth Activity Sheet, or you may want each student to complete his or her own sheet.

Tell the students to follow the directions on the Youth Activity Sheet and complete the data table.

Make sure that each group connects its batteries correctly—the positive terminal from one battery must be connected to the negative terminal of the next.

After the groups have had a chance to collect their data, have each group report their data to the class and record the observations on the board. In this way, each group serves as a repeated trial in the experiment. The number of paper clips picked up for each number of wraps of wire will vary from group to group.

Once the data is collected and displayed on the board, have the groups find the average number of paper clips picked up for each number of wraps of wire (average the observations of all the groups.)

Ask the groups to plot the data that they generated as a class. You might have some groups make bar graphs and some make line graphs.

Lesson 7 — Build an Electromagnet

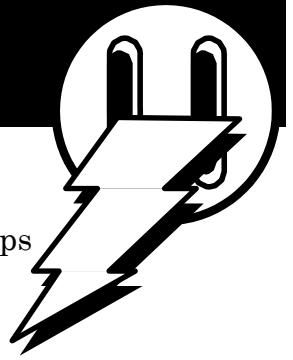

Ask the class to draw a conclusion from their data. Does the number of wraps of wire around the nail affect the strength of the electromagnet?

In general, the greater the number of wraps of wire the stronger the electromagnet, and the more paper clips picked up.

■ Evaluation (Answer Sheet)

1. Why did you draw numbers to determine the order in which you tested the number of wraps of wire?

2. Why did the class combine their data?

For each of the following questions, mark the correct answer:

3. When electricity flows, a magnetic field is present.

- True False

4. An electromagnet demonstrates that

- electricity produces a magnetic field.
 gravity is a natural force.
 static electricity can be used.
 Don't know.

5. When conducting an experiment, why is data collected?

- To take up class time
 To practice writing
 To provide information about the experiment

Lesson 8 — Electrical Safety



■ **Life Skill Objective** - decision-making for personal safety

■ **Connection to Standards of Learning**

SOL 4.3 (a) states that the student will investigate and understand the characteristics of electricity.

■ **Time Required** - 1 hour

■ **Supply List**

- Pencils
- Youth Activity Sheet

■ **Background Information**

Electricity is always looking for the easiest path to ground. In this sense, ground is any avenue through which electricity travels to reach the earth. Electricity will travel through anything that is a “conductor” or something that is used to get to something else. Just as electricity travels from a battery through a wire to light a bulb or power an electromagnet, electricity could travel from energized equipment through a person to get to the earth, making people great conductors.

When electricity passes through the body, it’s called electrical shock and can be very damaging. The current may cause 1st, 2nd, or 3rd degree burns. It can be crippling, and a victim may lose one or more limbs where the electricity has destroyed tissue. An electrical shock can cause a person’s heart to stop, and sometimes, electrical shock victims die.

The typical voltage in a common household outlet is about 100 times greater than what is in a (D-cell) flashlight battery. But even the amount of voltage in an electrical outlet can push enough current through the human body to injure or kill a person, should he or she become a path to ground! Outside electrical equipment operates at thousands of times more voltage than what is found at a household outlet. Examples of outdoor electrical equipment include the following: substations, transmission towers, underground cables, pad-mount transformers, distribution lines and meter bases (see illustrations in youth activity sheet).

Science SOL
4.1 & 4.3

Lesson 8 — Electrical Safety

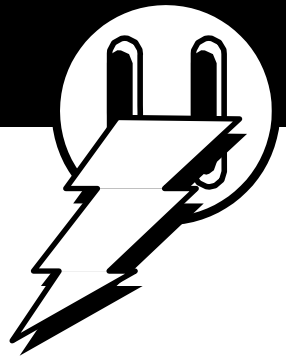

It's important to respect the power of electricity. For their own safety, youth must understand that they should stay away from outdoor electrical equipment. This means they should never climb transmission towers, service poles, substation fences, etc. No one should go near exposed or downed wires. Students should be instructed to immediately report such a problem to an adult; in turn, the adult should call the power company to get the problem corrected.

■ Procedure

Make sure that the students understand the following:

- Everyone should stay away from outdoor electrical equipment - it poses a potential hazard to anyone who tries to interact with it.
- Youth should use their knowledge about electrical safety to negotiate out of peer pressure situations.
- Youth should immediately report electrical hazards to an adult, who, in turn, should call the power company to get the problem corrected.

Show the various illustrations of outdoor electrical equipment to the class and discuss them to familiarize the students with the terminology. You might ask if they have seen any of this equipment, and if so, where is it located (near the school, their homes, etc.)?

Divide the class into groups and assign a different skit to each group. Tell the students to follow the directions on the Youth Activity Sheet. Each group will:

- assign actors
- read through one of the skits
- role play the scenario that is outlined, practicing a couple of times
- be prepared to perform its skit to the class

After the groups have had a chance to practice, ask each group to present its skit to the class.

Ask the students to complete the evaluation provided in the Youth

Science SOL
4.1 & 4.3



Lesson 8 — Electrical Safety



■ Answers to Youth Activity Sheet (none)

■ Evaluation

Evaluation Scenario #1

After explaining to Bobby that he could be seriously injured if he touches anything inside the transformer, Jenny should keep some distance from the transformer and seek adult intervention if possible. In the event that Bobby did get inside the transformer, Jenny should not approach it or Bobby, even if he is hurt. She should seek adult help.

QUESTION: What should Jenny do in this situation?

ANSWER: Jenny should step back from the hazard and continue to warn Bobby to stop. If he persists, she should get an adult or the bus driver to intervene. The adult should also call the power company to report damage to the equipment. These transformers are safe when locked, but they are equipment-not toys. Children shouldn't play on or around them, and if something looks damaged, the child should report it to an adult so the power company can be called.

Evaluation Scenario #2

Dennis should not retrieve the kite because in doing so, they might become a path for electricity and be seriously injured. Dennis and Kara should inform an adult about the kite and either they or the adult should inform the power company.

QUESTION: What should Dennis do? Should Dennis retrieve the kite? Why/why not?

ANSWER: No, Dennis should not retrieve the kite because electricity is always looking for a path to ground, and the current can travel through the string - and through Dennis - to reach the earth. Dennis should use his knowledge about electrical safety and refuse to retrieve the kite. The children should then go get an adult to call the power company.

Science SOL

4.1 & 4.3

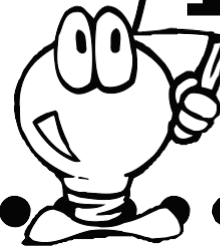

Magnetic Attractions

Name _____

1. Take the two bar magnets with the marked poles and bring them close together. A marked bar magnet will either be stamped with a N on one end and a S on the other, or one end will be painted and the other will not. Usually, the painted end is the north pole.

Write what happens when the magnets come close together:

Hint: What happens if you put two N poles together? _____

What happens if you put a N and a S pole together? _____

2. Using what you learned in number 1, how can you decide which end of the UNMARKED magnet is the N pole and which end is the S pole? _____

Take the pencil and mark the poles of the unmarked magnet N and S.

3. How can you check and see if you marked the poles on the unmarked magnet correctly? _____

4. What will the magnet attract? Test to see what materials the magnets are attracted to. _____

Complete the following table:

Material	Magnet Will attract	Magnet WILL NOT attract
paper	_____	_____
plastic	_____	_____
wood	_____	_____
paper clip	_____	_____
aluminum can	_____	_____
other (you list)	_____	_____

Magnetic Attractions



5. Determine where the magnetic field is the strongest. To do this, hold the magnet by one end and use the other end to pick up paper clips. How many did it pick up? _____

Now, hold the magnet by placing your fingers over both ends and see how many paper clips it can pick up in the middle of the bar. How many did it pick up? _____

Where is the magnet field stronger - near the poles or away from the poles in the middle?

6. What materials can a magnetic field pass through?

Place paper clips on the top of a piece of paper and put the magnet under the paper. Does the magnet attract the paper clips? Can a magnetic field pass through paper?

Place the paper clips in the water in the bowl. Hold the magnet above the paper clips. Can a magnetic field pass through water?

Will the magnetic field pass through air? _____ How can you test to find out? _____

What other materials can you test to see if a magnetic field will pass through?

Does it matter how thick the material is? (Example: a magnetic field will pass through one piece of paper, but will it pass through 25 pieces? 50 pieces?)

Assessment

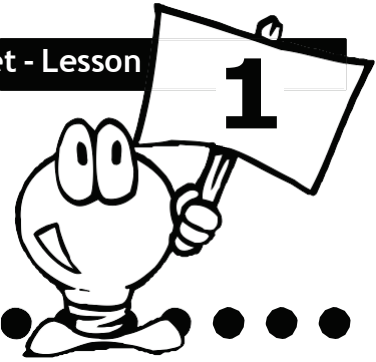

Name _____

For each of the following questions, mark the correct answer.

1. A magnetic field can be thought of as
 - something unnatural
 - a force field
 - something seen

2. Magnets have
 - east and west poles
 - north, south, east, and west poles.
 - left and right poles
 - north and south poles
3. "Like" poles of a magnet
 - attract each other
 - repel each other
 - both attract and repel each other

4. The north pole of a magnet is attracted to a certain part of the earth. That part is
 - London, England
 - the south pole
 - north pole
 - Washington, D.C.

5. Magnets are attracted to
 - water
 - certain types of metal
 - wood
 - sunlight

The Magnetic Field Around the Earth

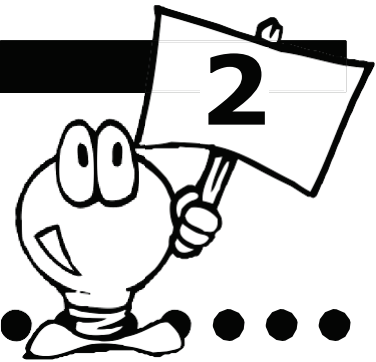

Name _____

Select one person in your group to magnetize the needle. To do this, stroke the needle **IN THE SAME DIRECTION** (not back and forth!) 50 times with the magnet.



Next, place the styrofoam disk in the bowl of water and place the magnetized needle on the styrofoam disk. The disk and needle should be able to float freely. The needle will point north /south.

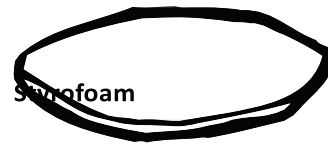

Answer the following questions:

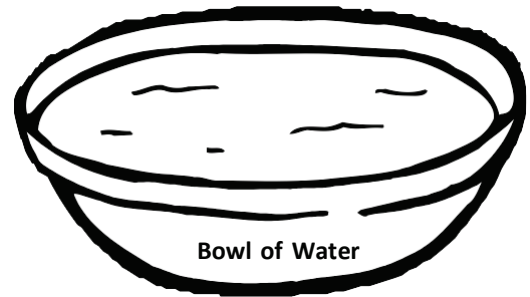

1. Why does the needle point north/south?
2. How can you tell which way is north and which is south? [Hint: How could you use the bar magnet to find out?]
3. Look at the compass another group has made. Is it pointing the same way as yours? How does it increase your confidence that the compass you made really works by looking at compasses other groups have made?
4. Why do you think scientists do the same experiment more than once?

Assessment

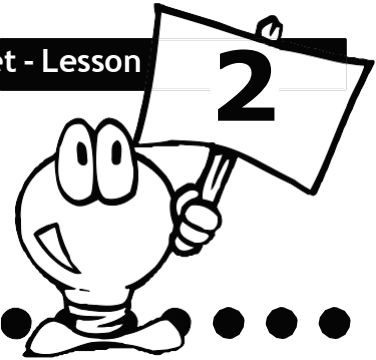

Name _____

For each of the following questions, mark the correct answer.

1. When you rub a magnet against a needle, what happens?

- the needle changes color
- the needle is magnetized
- the needle is energized
- nothing happens to the needle

2. The needle in a compass points:

- north/south
- east/west
- it depends on where you are when you use it
- toward the nearest electric outlet

3. The needle in a compass lines up with:

- the electric field around the earth
- the magnetic field around the earth
- the gravitational force around the earth
- all of the above

Assessment

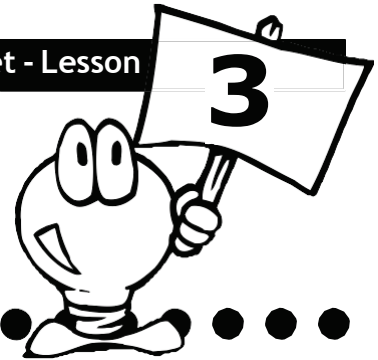

Name _____

Static electricity is a collection of _____.

Two balloons with a static charge will attract or repel each other?

For each of the following questions, mark the correct answer.

- All matter is composed of:
 fiber cells atoms minerals
- Two types of charges of an atom are:
 positive and negative.
 up and down.
 left and right.
 neutral and positive.
- Moving in an orbit around an atom's nucleus are:
 electrons protons neutrons Don't know
- When it is cold and dry and you rub your feet across a carpet, you can rub _____ off the carpet and collect them on your body.
 electrons
 protons
 atoms
 neutrons
- What charge do electrons have?
 positive
 negative
 neutral

Current Electricity and Circuit Building

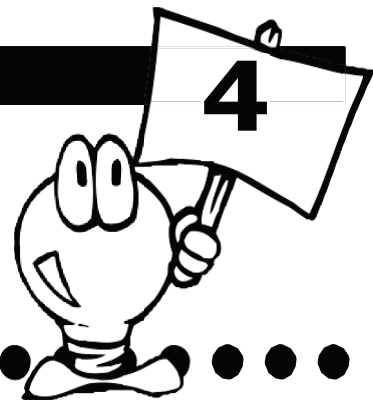

Name _____

Look at each of the electrical circuits and decide if there is a complete (closed) path for electricity to flow. If there is, when the circuit is built, the light will be on. If there is not a complete path, then the circuit is open and, when you build the circuit, the light will not be on. For each drawing, first predict if the light will be on, then build the circuit and test your results.

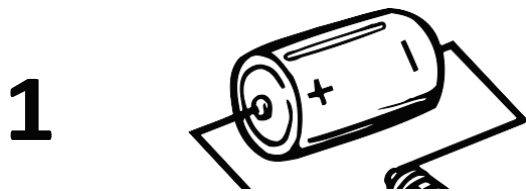

Predict: OPEN CLOSED
 Test Results: OFF ON

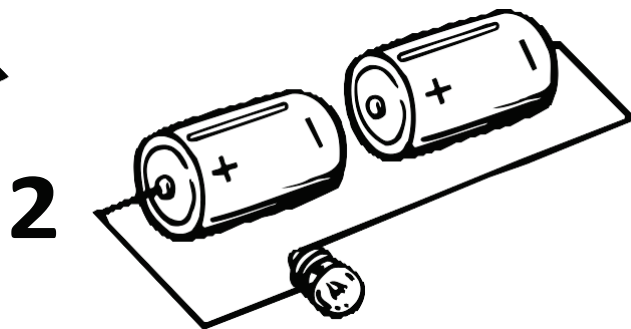

Predict: OPEN CLOSED
 Test Results: OFF ON

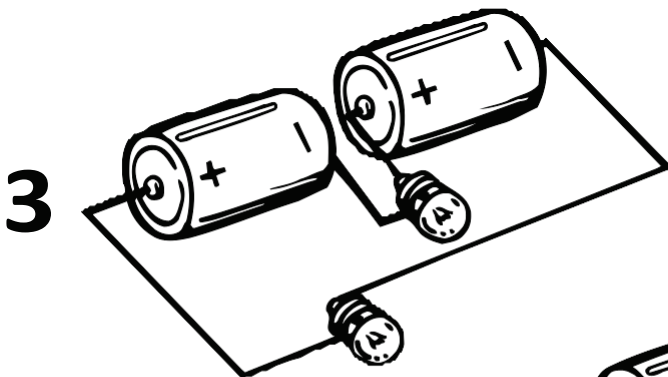

Predict: OPEN CLOSED
 Test Results: OFF ON

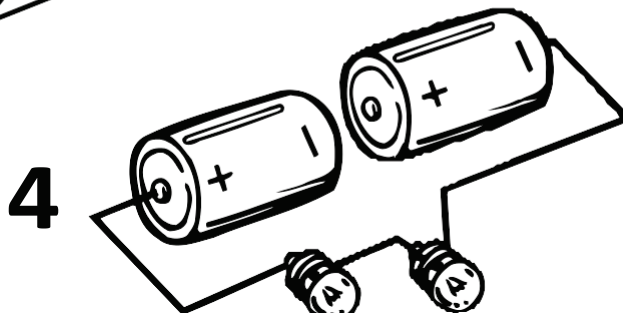

Predict: OPEN CLOSED
 Test Results: OFF ON

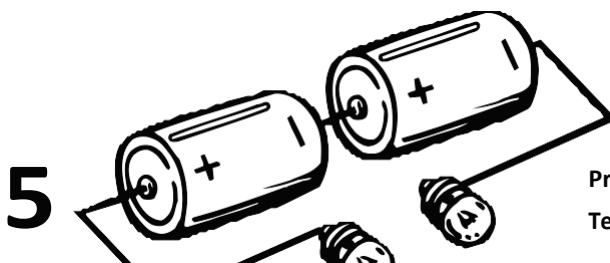

Predict: OPEN CLOSED
 Test Results: OFF ON



Assessment

Name _____

1. An open circuit will allow electrons to flow.
 - True
 - False
2. If a light is on, the circuit is _____ (open or closed).
3. Mark the following, as open or closed.

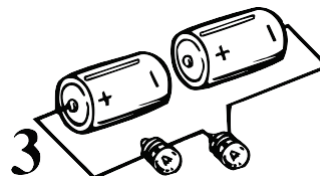
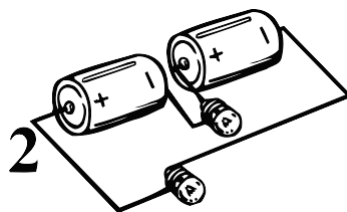
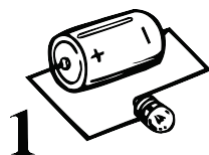

For each of the following questions, mark the correct answer.

4. When we talk about “electricity” we are usually referring to
 - static electricity
 - current electricity
 - neutron electricity
 - proton electricity
5. Electricity can be defined as the flow of
 - neutrons
 - protons
 - electrons
6. In order for electricity to flow, two things are necessary-something to push and a path to travel.
 - True
 - False
7. The force that pushes electrons is called:
 - voltage
 - current
 - magnetism
 - gravity
8. The flow of electrons is called:
 - voltage
 - magnetism
 - current
 - gravity
9. The flow of electrons is measured in units called:
 - amperes
 - feet
 - pounds
 - millimeters

Conductors and Insulators

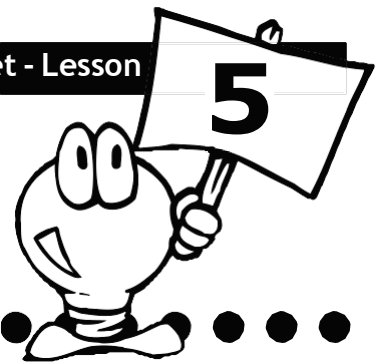

Name _____

Wrap the stripped end of one wire around one of the brass paper fasteners.



After making a switch, build a circuit with a battery, a light bulb and your switch. Try opening and closing the switch and see if it will turn the light on and off. When the light is on, is the circuit open or closed?

Place the brass paper fastener with the wire attached through the paper clip.



Wrap the second wire around the second brass fastener (just like step 1).

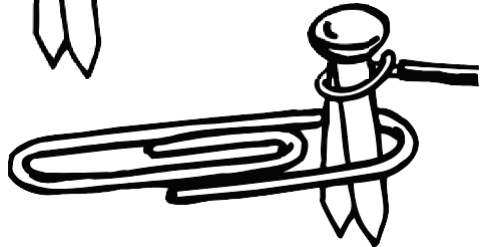

Make a hole in the piece of cardboard with a pencil and stick the first fastener with the paper clip through the hole.

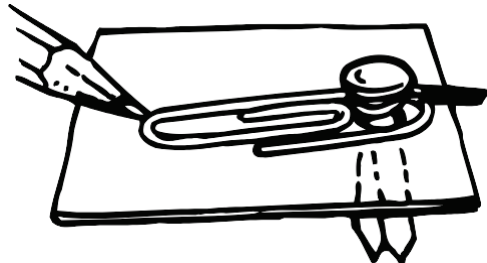

Mark the place where the end of the paper clip falls on the cardboard.

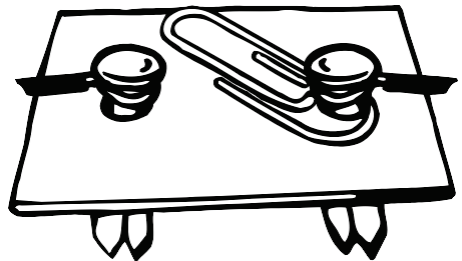

Make another hole with your pencil at the mark on the cardboard and push the second paper fastener through it.

Turn the cardboard over and open up the fasteners. You can put tape over the open fasteners to hold them securely.

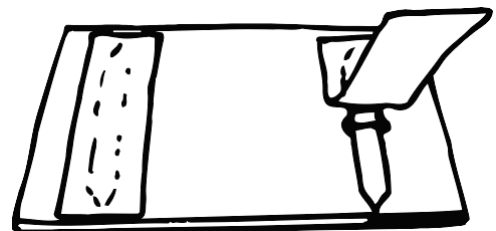

Conductors and Insulators



Name _____

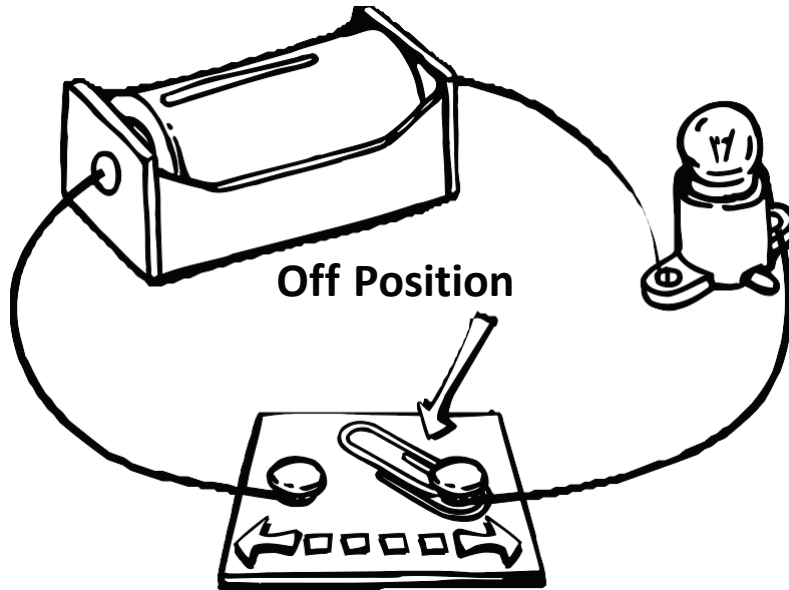

Place your material across both paper fasteners to complete the circuit test.

Data Table

Material	Prediction (conductor or Insulator)	Test Light (on or off)	Test Result (conductor or insulator)
<u>Metal paper clip</u>	_____	_____	_____
_____	_____	_____	_____
_____	_____	_____	_____
_____	_____	_____	_____

Is air an insulator or conductor? How do you know?

What type of clothing do you think should be worn when working with electricity?

Why do you think extension cords are covered with plastic or rubber?

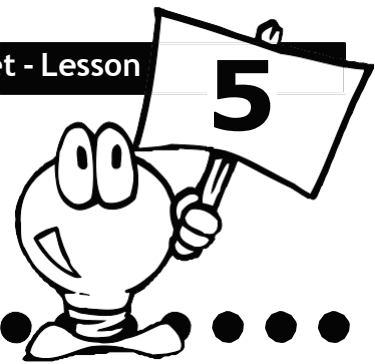

Assessment



Name _____

For each of the following questions, mark the correct answer.

1. For each material, mark I for insulator or C for conductor.

I		C		I	C		I	C
Wood	<input type="radio"/>	<input type="radio"/>	Rubber	<input type="radio"/>	<input type="radio"/>	Plastic	<input type="radio"/>	<input type="radio"/>
Copper	<input type="radio"/>	<input type="radio"/>	Glass	<input type="radio"/>	<input type="radio"/>	Air	<input type="radio"/>	<input type="radio"/>
Metal	<input type="radio"/>	<input type="radio"/>						

2. The purpose of an electric switch is

- a. to measure amounts of electricity
- b. to redirect the flow of electricity
- c. to turn the flow of electricity off and on

3. All materials allow electrons (electricity) to flow.

- True
- False

4. Materials called conductors have _____ resistance to the flow of electrons (electricity).

- Low
- High
- Medium

5. Materials called insulators have _____ resistance to the flow of electrons (electricity).

- Low
- High
- Medium

6. Which of the following would not be a good conductor of electricity?

- copper
- aluminum
- wood
- metal

7. Which of the following would not be a good insulator of electricity?

- rubber
- metal pipe
- plastic
- glass

Circuit Building



.....
Name _____

Using the materials you have, build the following circuit:

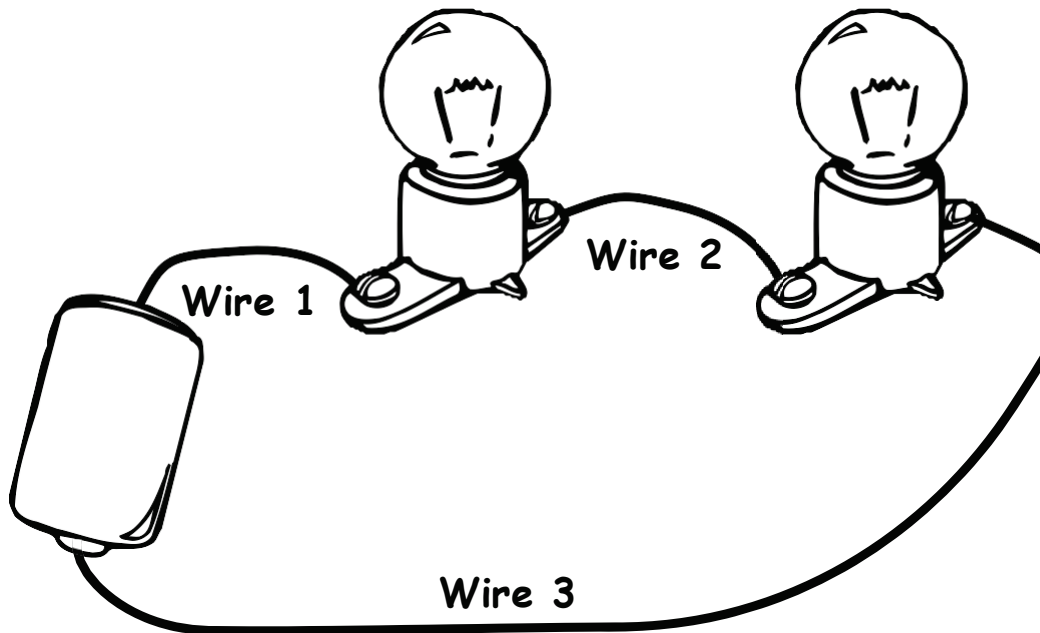

After you have built the circuit, take your finger and trace the path that the electrons follow from the negative terminal of the battery back to the positive terminal. Describe the path in words:

Unscrew one of the bulbs in the circuit. What happens and Why? Record your answer.

When you traced the path for electrons to flow, was there more than one path?

Circuit Building

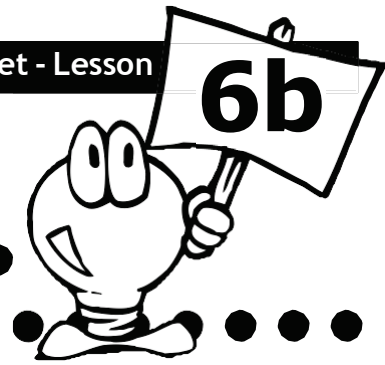

Name _____

What do you call this type of circuit? _____

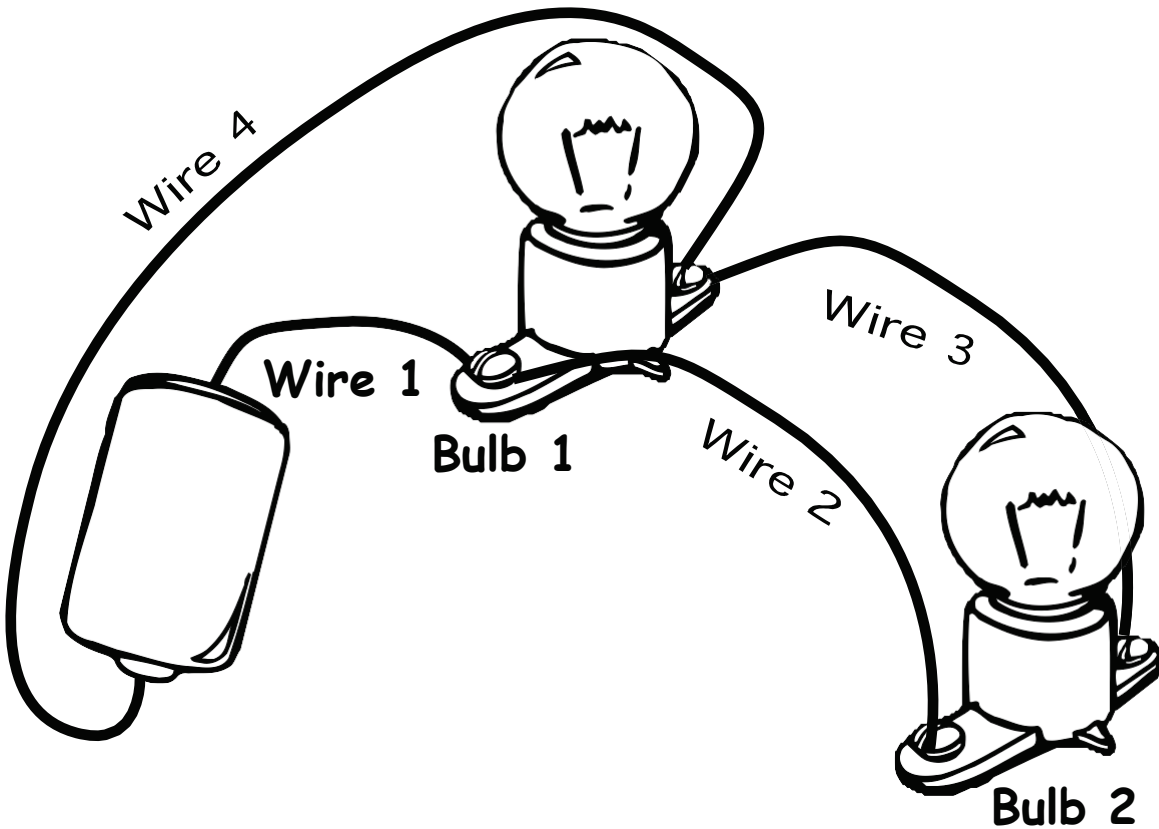

Build the following circuit:

After you have built the circuit, take your finger and trace the path that the electrons follow from the negative terminal of the battery back to the positive terminal. Describe the path in words:

Was there ever a point when the electrons could go to more than one place (a branch in the circuit)? What type of circuit is this? _____

Unscrew one of the light bulbs in the circuit. What happens to the other one and why?

Assessment

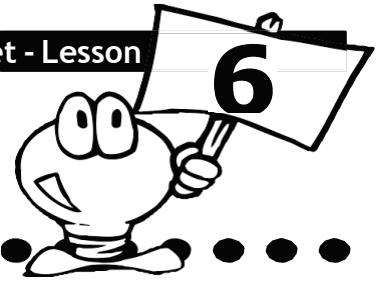

Name _____

For each of the following questions, mark the correct answer.

1. In a series circuit with two light bulbs, if one of the bulbs burns out, the other bulb will:
 - go out also
 - burn more brightly
 - not change at all
 - burn less brightly
2. In a parallel circuit with two light bulbs, if one of the bulbs burns out, the other bulb will:
 - go out also
 - burn more brightly
 - not change at all
 - burn less brightly
3. In a series circuit the electrons:
 - have only one path to follow
 - have more than one path to follow
 - only flow if it is an open circuit
 - a and c are both correct answers
4. In a parallel circuit the electrons:
 - have only one path to follow
 - have more than one path to follow
 - only flow if it is an open circuit
 - a and c are both correct answers
5. The circuits in my house are wired in parallel because:
 - if they were in series, and I turned off one appliance, all the other appliances on the same circuit would go out too.
 - it takes less wire to make a parallel circuit
 - a parallel circuit is safer
 - they are wired in series, not parallel.

Build and Test an Electromagnet



Name _____

Start by randomizing the order in which you will collect your data. To do this, on separate slips of paper, write the numbers 5, 10, 15, and 25. Fold the papers and let one person in the group hold them. Have someone draw a number. In the data table, write down the number drawn in the first row under “number of wraps.” Then have another group member draw another number. Write the second number drawn in the data table in the second row, same column. Draw a third number and write it in the data table in the third row. Record whatever number is left in the fourth row of the data table. Conduct your tests in the order you just listed in the data table. For example, if the first number drawn was 10, then the first test will be done with 10 wraps of wire.

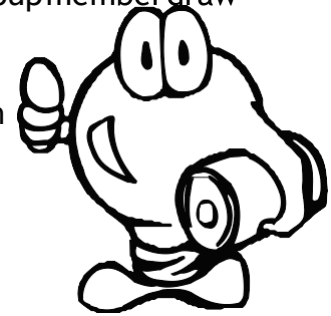

Number of Wraps of Wire (determined by random drawing)	Number of Paper Clips Picked Up (observed from test)

To make the electromagnet, hold the wire about 6 inches from one end and begin wrapping it around the nail. Wrap the wire around the nail the number of times needed for the first test (see your data table—this is the first number that you drew).

Next, build a battery source by putting your two batteries into the battery holders and connecting them in series. Make sure you connect them in the right order (think about how you put batteries in a flashlight—does the order matter?). Next, add the switch that you made in the last activity.

Connect your electromagnet to the batteries and the switch (see the circuit diagram).

Build and Test an Electromagnet



.....
Name _____

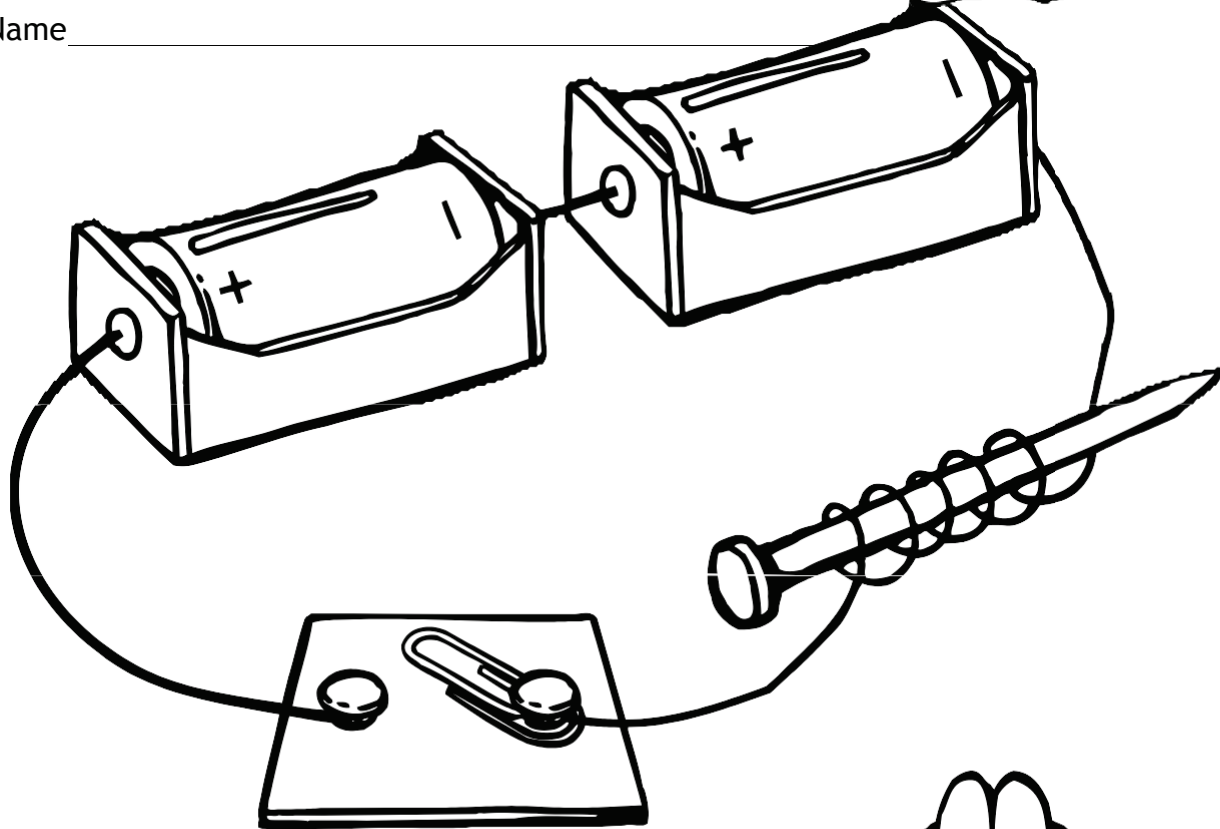

Close the switch and hold the electromagnet near the pile of paper clips. Count how many paper clips your electromagnet picked up. Record in the data table the number of paper clips the electromagnet picked up for the corresponding number of wraps of wire. Now open the switch.

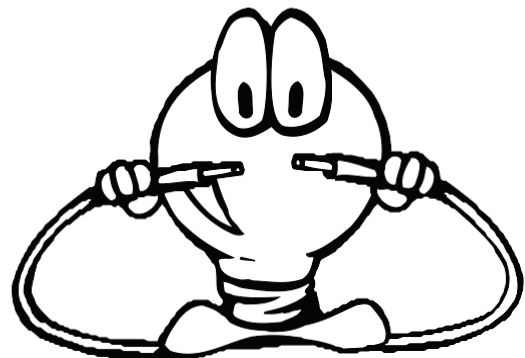

Change the number of wraps of wire around the nail to the number for the second test (whatever order you randomly selected). Close the switch and try again to see how many paper clips the electromagnet will pick up. Record your observation. Continue your test for the remaining numbers of wraps of wire. Be sure and open your switch between tests so that you do not use up your batteries.



Build and Test an Electromagnet



Name _____

Class Data Table

Number of paper clips picked up

Number of Wraps	Group 1	Group 2	Group 3	Group 4	Group 5	Group 6	Group 7	Group 8	Group 9	Avg.
5										
10										
15										
25										

After each group has collected its data, they will share their data with the class. Record the data as the teacher writes it on the board.

Now find the average number of paper clips picked up for each number of wraps of wire. To do this, add all the numbers and divide by the number of groups.

Draw a graph with the number of paper clips picked up on the y-axis and the number of wraps of wire on the x-axis.

Does the number of wraps of wire make a difference on the number of paper clips picked up?



Assessment



Name _____

1. Why did you draw numbers to determine the order in which you tested the number of wraps of wire?

2. Why did the class combine their data?

For each of the following questions, mark the correct answer:

3. When electricity flows, a magnetic field is present.

- True
- False

4. An electromagnet demonstrates that

- electricity produces a magnetic field.
- gravity is a natural force.
- static electricity can be used.
- Don't know.

5. When conducting an experiment, why is data collected?

- To take up class time
- To practice writing
- To provide information about the experiment

Electricity Skit #1

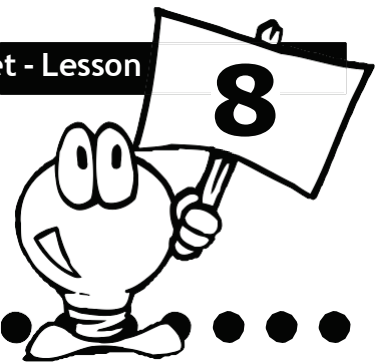

Name _____

Your group has been assigned one of the skits below. In order to be prepared to perform your skit to the class, you will need to:

- assign actors
- read through the skit
- role play the scenario that is outlined, practicing a couple of times

Skit #1: The Transmission Tower: To Climb or Not to Climb

Chris, Shayne and Lee are riding their dirt bikes along a back road. When they see the transmission tower, they decide to take a little break...

Chris: Hey, this looks like an awesome place to play.

Shayne: Yeah, man, check out the tower! It looks pretty cool!

Lee: I don't know. It looks dangerous.

Chris: Dangerous!? What, are you scared to climb it? I dare you.

Shayne: Yeah, climb it! I'll bet you can see my house from up there!

Lee: No, listen, I'm serious. I think that's a transmission tower, and has dangerous stuff on it. I think electrical wires are on it.... I don't think we should climb it.

Chris: Whatever. You're just scared!

Lee: I've heard what happens to people who "touch" electricity- they get shocked. You could lose your arms or legs. That's not cool.

Chris: There's no electricity on there. You're just too scared to try and climb it. I'm gonna tell everyone at school that you're too scared to climb up a stupid tower!

Shayne: Hold on- Lee might be right. I saw this on t.v. once. Electricity is always looking for something to take it to the ground, and it can travel through us - so if electrical lines are attached to the tower, and you climb the tower, then you could get zapped and get hurt badly.

Electricity Skit #1 cont'd

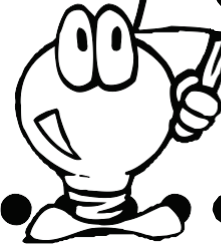

Chris: Oh no, not you too! Why do I hang out with such wimps!

Lee: Listen - I'm not being a wimp. I just don't think climbing the tower is a good thing to do. I mean, yes, there's electricity there, and even though I'll bet the town looks really cool from up there, I'm not going to be the one that gets zapped.

Shayne: (to Lee) I'm with you, man. Come on. Let's keep on riding.

Chris: Whatever... I wanted to go home and play video games anyway.

Electricity Skit #2

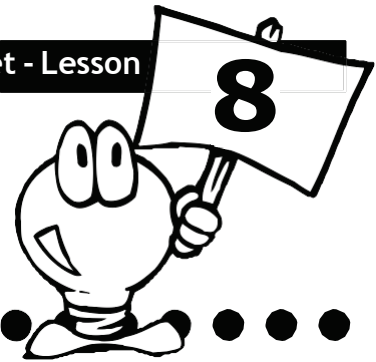

Your group has been assigned one of the skits below. In order to be prepared to perform your skit to the class, you will need to:

- assign actors
- read through the skit
- role play the scenario that is outlined, practicing a couple of times Skit #2: Substation Drama

Emily, Sidney, Flynn and Joe are playing soccer. Emily accidentally kicks the ball into the nearby substation...

Emily: Wow, did you see how far that ball went?

Sidney: Yeah... I think it was a goal!

Flynn: Way to go, look where it went... great. Now who's going to go get it?

Sidney: Hey, Emily, you kicked the ball over there. You go get it!

Emily: I can't really see it. I think it went over there by that building with all the wires... I'll be right back. Don't worry, we'll be playing again in just a minute.

Joe: Wait a minute - I wouldn't.

Emily: What, are you crazy or something? Don't you want to go get the ball and keep playing?

Joe: It looks kind of dangerous. That building with the wires, well, my dad said that's a substation - and it's full of live electricity.

Sidney: How do you know that?

Flynn: Joe doesn't know anything. Joe, you're just mad because Emily scored a goal and now you want to quit playing.

Joe: No way, I'm for real! We'll go get another ball and keep playing. But if we go over there, we could really get hurt!

Electricity Skit #2 cont'd

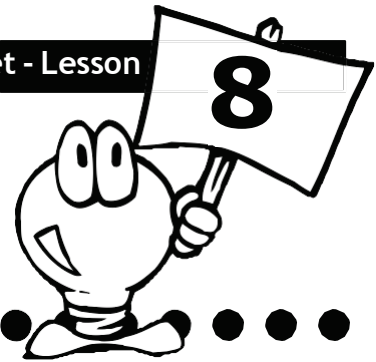

Emily: What do you mean? It's just a bunch of wires.

Joe: My dad told me all about substations. They supply all the power and electricity for the town, which means they're full of electrical equipment. Plus, electricity is always looking for a path to ground - and that means it can even travel through the wires and through us to get there. Not cool!

Emily: Well, so what? It can't hurt us.

Sidney: Yeah, it can't hurt us.

Joe: That's not what my dad said! You could get shocked, or burned, or worse. You could even die. Losing the ball is no big deal... I'll run home and get my mother to call the power company to get it out of there. It's their land anyway. I'll get another ball while I'm home so we can keep playing in the meantime.

Flynn: Alright. Hurry back!

Electricity Skit #3

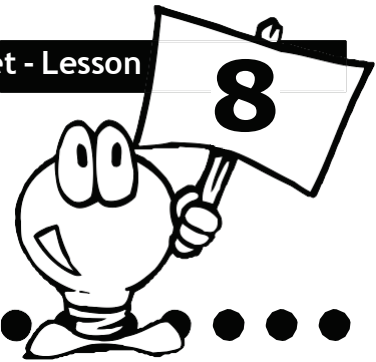

Name _____

Your group has been assigned one of the skits below. In order to be prepared to perform your skit to the class, you will need to:

- assign actors
- read through the skit
- role play the scenario that is outlined, practicing a couple of times

Drama Skit #3: Downed Wires

Pat, Sam and Kelly are walking home together after a storm and talking about it when they come across a wire down in the middle of the road...

Pat: That was an awesome storm!

Sam: Yeah! The lightning was so cool!

Kelly: Look! There's something up ahead lying in the middle of the road! It looks like a giant snake!

Sam: It's not a snake. It's just a wire coming from the pole that probably fell in the storm. I'll race ya to it!

Pat: (running) Last one there has to jump it!

(The children run toward the line, but stop just before. Kelly is last.) Pat:

(to Kelly) You lose. You have to jump over the wire now. A-ha!

Kelly: What's your problem? You're not supposed to jump over wires on the ground. It could be an electric power line and have electricity in it.

Pat: Whatever. It's just a little wire! It's probably a telephone line. Wait, shouldn't we move it out of the street somehow so cars don't drive over it?

Kelly: You must not know anything about electricity and the harm it can do. If that's a power line, anything coming down from the pole could carry electricity, and electricity is always looking for a path to ground... so we shouldn't touch it or go near it at all.

Electricity Skit #3 cont'd

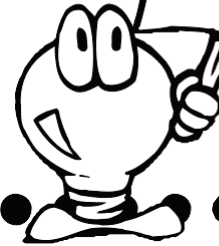

Sam: (sarcastically) Oooh, Pat doesn't know anything about electricity.

Kelly: I'm serious, man! That's powerful stuff - I've heard that just the electricity in an outlet in your house is enough to kill you if you touch it - so imagine how much electricity is in this wire!

Pat: You're just afraid your hair is gonna stand up if you go near it. Heh. Heh.

Kelly: You could actually get seriously burned and not be able to walk again. You could lose your arms or legs. Sometimes people even die when electricity "touches" their bodies.

Sam: Really? I didn't know that.

Pat: Let's cross the street and get away from the line. When I get home, I'll get my aunt to call the power company and get it taken care of.

Kelly: That's cool... I was getting hungry anyway.



Evaluation



Name _____

Evaluation Instructions - Read each scenario below and answer the question(s) that follow. All answers should be in paragraph form, using complete sentences.

Evaluation Scenario #1

Bobby and Jenny are waiting at a school bus stop. There is a pad-mounted transformer nearby and Bobby and Jenny decide to play around it. Bobby starts poking the door of the transformer with a metal ruler and jimmies the door open a crack. Jenny asks Bobby to please stop, but he won't.

QUESTION: What should Jenny do in this situation?

Evaluation Scenario #2

Kara and Dennis are flying a kite. The kite blows into some power lines. Kara tells Dennis to go get the kite.

QUESTION: What should Dennis do? Should Dennis retrieve the kite? Why/why not?



1 Power

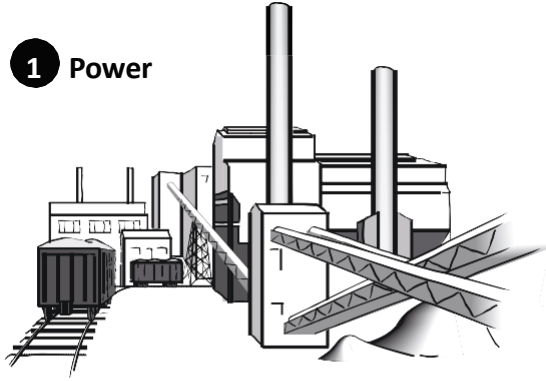

2 Transmission Tower &

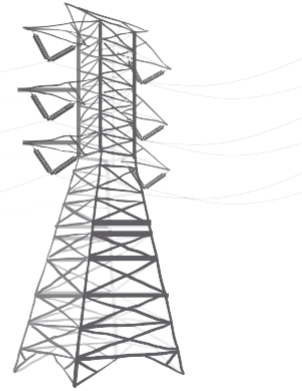

3

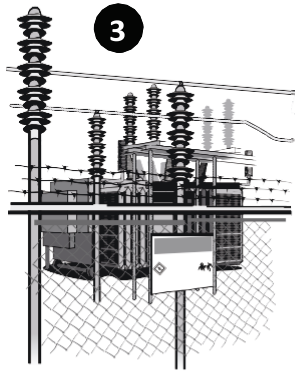

4 Distribution

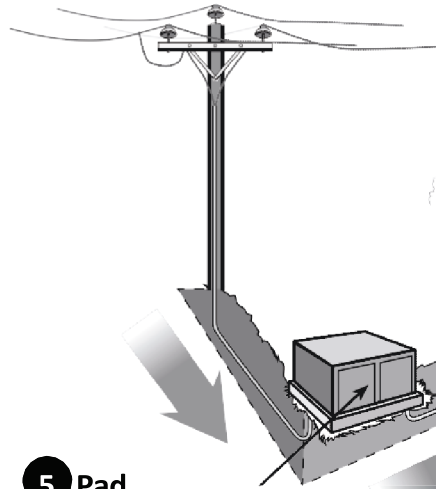

5 Pad Mounted

6 Meter

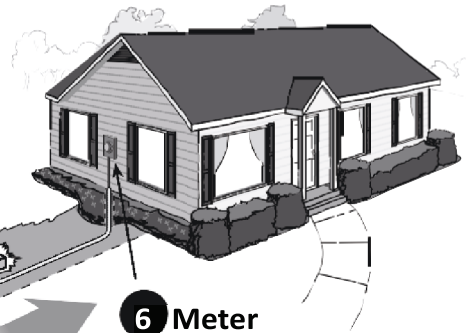

© 2000 Dominion

Power Station to Home

Electricity is generated at power stations (1). It then travels long distances through transmission lines (2) to substations (3). At a substation, special equipment “steps down” the electricity from extremely high voltage to lower voltage and regulates its flow. Electricity is then transported through distribution lines (4) to local places such as neighborhoods. A pad-mounted transformer (5) or pole-mounted transformer (not shown) lowers the voltage again before the electricity is sent to houses. The meter base (6) is where the electricity enters your home.



Clarke County 4-H After-School Program Participant Survey

FY 14 (October 2013- September 2014)

Circle or print the best answer to each question. There are no right or wrong answers and they will not be shared with anyone.

Are you a boy or a girl?

Boy Girl

What was your favorite part of this program?

How old are you?

Would you like to attend the science program again?

What grade are you in?

Color the face that best answers each question.



	Yes	Sometimes	No
I like to see how things are made or invented			
I like experimenting and testing ideas			
I get excited about science			
I want to learn more about science			
I like science			
I am good at science			
I would like to have a job related to science			
I do science activities that are not for school			

www.ext.vt.edu

Experiential Learning Survey

I. Experiential Learning Objectives

Please place an 'X' in the box that best answers the question.

Does this curriculum provide students with the opportunities to ...	Strongly disagree	Disagree	Neutral	Agree	Strongly agree
<p>a. Explore, examine or arrange through hands-on learning experiences</p>					
<p>Please provide feedback for your response:</p>					
<p>b. Share what happened through their results and reactions</p>					
<p>Please provide feedback for your response:</p>					
<p>c. Discuss and analyze their results</p>					
<p>Please provide feedback for your response:</p>					
<p>d. Connect their experiences to real-world examples</p>					
<p>Please provide feedback for your response:</p>					
<p>e. Apply and practice what they learned</p>					
<p>Please provide feedback for your response:</p>					

II. Program Objectives

Please place an 'X' in the box that best answers the question.

As a result of participating in a program that utilizes this curriculum and emphasizes on experiential learning, youth will...	Yes	No
a. Have an increased interest in STEM learning opportunities		
b. Benefit from participating in STEM learning opportunities		
c. Aspire to participate in future STEM learning opportunities		

III. Additional Comments

Please provide any additional comments you have about the survey or about experiential learning as it relates to the Virginia 4-H Electricity School Enrichment Curriculum.

Simply Science



BES 4-H Enrichment Program

Brought to you in collaboration with Boyce Elementary School

Class Day: Tuesdays, 3:30– 5:00 p.m.

5 Week Program, April 1st– May 6th

(There will be no session on April 15th due to CCPS Spring Break)

Cost: Free for grades 4-5;

however, please provide a snack for your child!

Location: BES cafeteria

Registration Deadline: Friday, March 28th

To register, please call the VCE Clarke Office at 540.955.5164

or email kailamh@vt.edu and return the attached 4-H Health History Form

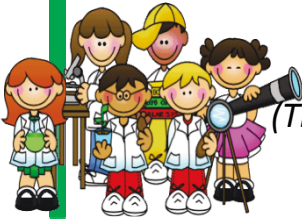

ELECTRIFY your ENTHUSIASM for SCIENCE & EXPLORE the FUN-damentals of ELECTRICITY!

Magnetic Attractions: Opposites Attract

Become a mad scientist, unlock the mysterious powers of magnets and learn some tricks of the magnet magic trade!

Static Electricity: Charge vs Shock

Learn all about static charge and static shock while comparing the affect of these electric charges on moving objects!

Current Electricity and Circuit Building

Think like a electrical engineer, assemble your own circuit and learn about different circuits and electrical behaviors.

Flow of Electricity: Conductors vs Insulators

Is it a conductor? Is it an insulator? Become an electricity expert while learning about what can conduct electricity, what can stop its flow, and the important parts of circuits.

Electromagnets

Electromagnets aren't just used for picking up scrap metal at the dump; come explore how electromagnets are used everyday!



“Clarke County 4-H”

If you are a person with a disability and desire assistance or accommodation, please notify Clarke County Extension Office at (540-955- 5164/TDD*) during business hours of 8:30 a.m. and 5 p.m. *TDD number is (800) 828-1120.

