

Algorithms and Simulation Framework for Residential Demand Response

Rajendra Adhikari

Dissertation submitted to the faculty of the Virginia Polytechnic Institute and State University in partial fulfillment of the requirements for the degree of

Doctor of Philosophy in Electrical Engineering

Saifur Rahman, Chair
Manisa Pipattanasomporn
Virgilio A. Centeno
Guoqiang Yu
Narendran Ramakrishnan

December 07, 2018
Arlington, Virginia

Keywords: Demand Response, DR Simulation Framework, Aggregated HVAC Control, Regulation, Load Reduction, Residential Building Control

Algorithms and Simulation Framework for Residential Demand Response

Rajendra Adhikari

Abstract

An electric power system is a complex network consisting of a large number of power generators and consumers interconnected by transmission and distribution lines. One remarkable thing about the electric grid is that there has to be a continuous balance between the amount of electricity generated and consumed at all times. Maintaining this balance is critical for the stable operation of the grid and this task is achieved in the long term, short term and real-time by operating a three-tier wholesale electricity market consisting of the capacity market, the energy market and the ancillary services market respectively. For a demand resource to participate in the energy and the capacity markets, it needs to be able to reduce the power consumption on-demand, whereas to participate in the ancillary services market, the power consumption of the demand resource needs to be varied continuously following the regulation signal sent by the grid operator. This act of changing the demand to help maintain energy balance is called demand response (DR). The dissertation presents novel algorithms and tools to enable residential buildings to participate as demand resources on such markets to provide DR.

Residential sector consumes 37% of the total U.S. electricity consumption and a recent consumer survey showed that 88% of consumers are either eager or supportive of advanced technologies for energy efficiency, including demand response. This indicates that residential sector is a very good target for DR.

Two broad solutions for residential DR are presented. The first is a set of efficient algorithms that intelligently controls the customers' heating, ventilating and air conditioning (HVAC) devices for providing DR services to the grid. The second solution is an extensible residential demand response simulation framework that can help evaluate and experiment with different residential demand response algorithms.

One of the algorithms presented in this dissertation is to reduce the aggregated demand of a set of HVACs during a DR event while respecting the customers' comfort requirements. The algorithm is shown to be efficient, simple to implement and is proven to be optimal. The second algorithm helps provide the regulation DR while honoring customer comfort requirements. The algorithm is efficient, simple to implement and is shown to perform well in a range of real-world

situations. A case study is presented estimating the monetary benefit that can be obtained by implementing the algorithm in a cluster of 100 typical homes and shows promising result.

Finally, the dissertation presents the design of a python-based object-oriented residential DR simulation framework which is easy to extend as needed. The framework supports simulation of thermal dynamics of a residential building and supports house hold appliances such as HVAC, water heater, clothes washer/dryer and dish washer. A case study showing the application of the simulation framework for various DR implementation is presented, which shows that the simulation framework performs well and can be a useful tool for future research in residential DR.

Algorithms and Simulation Framework for Residential Demand Response

Rajendra Adhikari

General Audience Abstract

The total power generation and consumption has to always match in the electric grid. When there is a mismatch because the generation is less than the load, the match can be restored either by increasing the generation or by decreasing the load. Often, during system stress conditions, it is cheaper to decrease certain loads than to increase generation, and this method of achieving power balance is called demand response (DR).

Residential sector consumes 37% of the total U.S. electricity consumption and is largely unexplored for demand response purpose, so the focus of the dissertation is on providing solutions to enable residential houses to provide demand response services.

This dissertation presents two broad solutions. The first is a set of efficient algorithms that intelligently controls the customers' heating, ventilating and air conditioning (HVAC) devices for providing DR services to the grid while keeping their comfort in mind. The second solution is a simulation software that can help evaluate and experiment with different residential demand response algorithms.

The first algorithm is for reducing the collective power consumption of an aggregation of residential HVAC, whereas the second algorithm is for making the collective power follow a signal sent by the grid operators. It is shown that the algorithms presented can intelligently control the HVAC devices such that DR services can be provided to the grid while ensuring that the temperatures of the houses remain within comfortable range. The algorithms can enable demand response service providers to tap into the residential demand response market and earn revenue, while the simulation software can be valuable for future research in this area.

The simulation software is simple to use and is designed with extensibility in mind, so adding new features is easy. The software is shown to work well for studying residential building control for demand response purpose and can be a useful tool for future research in residential DR.

Acknowledgements

First, I would like to thank my advisor, Dr. Saifur Rahman, as this dissertation would not have been possible without his guidance from the start to the end. His advice to look at the big picture of what I am doing in terms of how and if it is valuable to others have been the guideline for my work. His terse but effective comments have many times helped me find my path when I was lost. I am grateful to have him as my advisor.

Next, I cannot thank Dr. Manisa Pipattanasomporn enough. She has always been the go to person to seek help when I was stuck, a cheerleader to encourage me when I was feeling inadequate, reviewer and second author for most of my papers, and a caring friend who always kept the environment lively and cheerful. I could always count on her on rooting me, and that meant a lot.

I would also like to thank Dr. Virgilio Centeno, Dr. Guoqiang Yu, and Dr. Naren Ramakrishnan for serving in my PhD committee and providing valuable comments and suggestions.

I also thank Dr. Murat Kuzlu for his support and guidance during my initial stage of PhD and engaging me with pointed questions. I was very fortunate to have the pleasure to work with him.

I have to thank Yonael Teklu for being an awesome colleague and helping me throughout my time at ARI with all the different technical problems without ever getting annoyed no matter what.

I would also like to thank Xiangyu Zhang for being my closest friend at ARI from the beginning of my PhD journey, and always being there to listen to my rants, jokes, and my nonsense with supporting ears. Without venturing into exaggeration, I can say that your presence in the lab single handedly transformed my PhD from a lonely journey into a joyous adventure with a friend.

I can also not remain without thanking Mengmeng Cai, for being a very good friend at ARI. It has always been a lot of fun talking with you and your frankness and cheerfulness is admirable.

I would also like to thank Ashraful Haque, who has become a very close friend in a very short time. Thanks for being there to listen to my most bizarre thoughts and ideas, and supporting me during my stressful times.

I would also like to thank my past and present colleagues at ARI, Sneha, Kruthika, Avijit and Warodom, for helping me get started and for providing the support when required.

Lastly, I would like to thank my family; my parents, my brothers and my sister for always being there for me, believing in me and providing the love and care necessary to arrive to this point.

Thank you.

Table of Contents

1.0 Introduction	1
1.1 Background	1
1.2 Motivation.....	2
1.3 Objectives and Scope of the Work	3
Objective 1: To Develop a Set of Algorithms for an Effective DR Program for Aggregated HVAC Control that Respects Customers' Comfort Requirements	3
Objective 2: To Develop an Extensible Residential DR Simulation Framework	4
1.4 Tasks and Contributions	4
Task 1: Develop Optimal DR Algorithms for Controlling Aggregated HVAC Loads.....	4
Task 2: Develop an Extensible DR Simulation Framework	5
Task 3: Perform Simulation Studies to Evaluate the Effectiveness of the Developed DR Algorithms and the DR Simulation Framework	6
2.0 Literature Review	8
2.1 Demand Side Management and Demand Response.....	8
2.1.1 DR at the Retail Level	8
2.1.2 DR in the Wholesale Market	11
2.2 DR at Residential Sector	16
2.3 DR Implementations	18
2.3.1 Task Scheduling based DR.....	18
2.3.2 Energy Management based DR	18
2.3.3 Electricity Cost Minimization in Dynamic Pricing Scheme.....	18
2.3.4 Maximization of Social Welfare.....	19
2.3.5 Minimization of Power Consumption.....	20
2.3.6 DR Implementation Targeting HVAC control	20
2.3.7. DR implementation for providing regulation services using HVAC control.....	23
2.4 Residential Building and HVAC Control Based DR Simulation Tools	24
2.5 Knowledge Gaps.....	26
2.6.1 Optimal Aggregated HVAC Control DR Algorithms	26
2.6.2 Extensible DR Simulation Tool with Detailed Residential Module	27
3.0 Methodology.....	28
3.1 Optimal Aggregated HVAC Control DR Algorithm.....	28
3.1.1 Optimal Load Reduction DR Algorithm	28

3.1.2 Optimal Regulation DR Algorithm	39
3.2 Extensible DR simulation Framework with the Detailed Residential Module.....	50
3.2.1 Residential Building Thermal Model and HVAC Model Based on Physical Equations .	50
3.2.2 Appliances Models.....	53
3.2.3 Encompassing the Models into a Comprehensive Residential Building Simulation Framework	56
4.0 Case Study.....	65
4.1 Optimal Aggregated HVAC Control DR Algorithm Case Study.....	65
4.1.1 Case Study for Optimal Load Reduction DR Algorithm	65
4.1.2 Case Study for Optimal Regulation DR Algorithm	76
4.2 Extensible Residential DR Simulation Framework	82
4.2.1 House Thermal Behavior and HVAC Operation Simulation Case Study	82
4.2.2 Appliance schedule driver	83
4.2.3 A simple DR implementation with an appliance	83
4.2.4 Whole house simulation with 1000 houses	84
5.0 Conclusion and summary	86
6.0 Future Work	88
7.0 Appendix	90
8.0 References	95

List of Figures:

Figure 1: Electricity delivery overview	1
Figure 2. PJM Estimated Revenue for Economic and Load Management DR Markets	13
Figure 3: DR capacity commitment in the PJM market over time	14
Figure 4: DR company types in the PJM market [22].....	16
Figure 5: Contribution of various sector to the wholesale DR	16
Figure 6: US electricity use by sectors.....	17
Figure 7: US electricity use by end-use types	17
Figure 8: Framework for optimal DR.....	29
Figure 9: ETP model for a house	31
Figure 10: (a) Illustration of the typical operation of AC (b)Alternate view of the problem	34
Figure 11: (a) Illustration of the implication of transforming the y-axis from temperature to time-to-boundary. (b) Results after transforming the representation in figure 10(b) to represent the time-to-boundary as the height of each ball.....	35
Figure 12: RegA regulation signal generation block diagram.....	39
Figure 13: Test RegA signal from PJM	39
Figure 14: RegD Regulation signal generation block diagram.....	40
Figure 15: Test RegD signal from PJM	40
Figure 16: Illustration of regulation service	41
Figure 17: Proof of non-existence of optimal regulation algorithm	44
Figure 18 Performance of the Greedy Algorithm(GA) with a test regulation signal	48
Figure 19 Performance of the Lazy Algorithm(LA) with a test regulation signal	48
Figure 20 Average PS and regulation credit variations with RegMW for RegD.	50
Figure 21: ETP model of a house	51
Figure 22: Simulating a bunch of bouncing balls in a box.....	56
Figure 23: Illustration of discrete event simulation process	59
Figure 24: Clothes washer load shape	60
Figure 25: Flowchart of Appliance model and schedule driver model working together	61
Figure 26: Simulation Framework.....	63
Figure 27: Class inheritance diagram of major processes of the simulation framework	64
Figure 28: Solution Time growth rate with problem size.....	67
Figure 29: Aggregated HVAC power, outdoor and indoor temperatures in the base case without control (Base Case).....	69
Figure 30: Aggregated HVAC power, outdoor and indoor temperatures with the JA (Case I).	69
Figure 31: Aggregated HVAC power, outdoor and indoor temperatures with the set-point change based control (Case II).....	70
Figure 32: Aggregated HVAC power, outdoor and indoor temperatures with JA and a restrrike limit (Case III.1).	71
Figure 33: Aggregated HVAC power, outdoor and indoor temperatures with JA with conservative demand limit (Case III.2).....	72
Figure 34: Aggregated HVAC power, outdoor and indoor temperatures with JA, demonstrating randomized constraints (Case IV).	73
Figure 35: Distribution of comfort violation index among the houses.....	74

Figure 36 PS for various regulation cases with GA and LA algorithms	76
Figure 37 A typical example day difference in PS: (a) LA performing better than GA; and (b) GA performing poorly than LA	78
Figure 38 (a) Impact of base set point on regulation credit; (b) Impact of comfort range on PS; (c) Impact of time delay on PS; (d) Average PS and regulation credit variations with RegMW for RegA signals; and (e) Impact of regulation on AC cycling.	79
Figure 39 Total regulation credit in dollars. Black areas are hours when the total regulation capacity was less than 100kW and no regulation is provided.	81
Figure 40: Comparison between the simulation result of the proposed Simulator and GridLAB-D	82
Figure 41: Aggregated power of a collection of clothes washers	83
Figure 42: DR event response of a group of clothes washers	84
Figure 43: Code sample for 1000 house simulation	84
Figure 44: Simulation result for 1000 houses DR	85
Figure 45: Transformation of the problem to represent the time-to-boundary as the height of each ball.....	90
Figure 46: Dividing the DR periods into z intervals.....	90
Figure 47: Illustration of the exchange step at time step $t=k$	93

List of Tables

Table 1: Wholesale market DR opportunities	15
Table 2: Summary of load reduction simulation Results	73
Table 3: Regulation DR results summary	80

1.0 Introduction

Introduction to this dissertation begins with a brief background about the electricity market and its needs, followed by the motivating problems. Then it is followed by listing out the objectives and scope of the dissertation. Finally, specific tasks completed and their contributions are listed out.

1.1 Background

An electric power system is a complex network consisting of a large number of power generators and consumers interconnected by transmission and distribution lines, as shown in Figure 1.

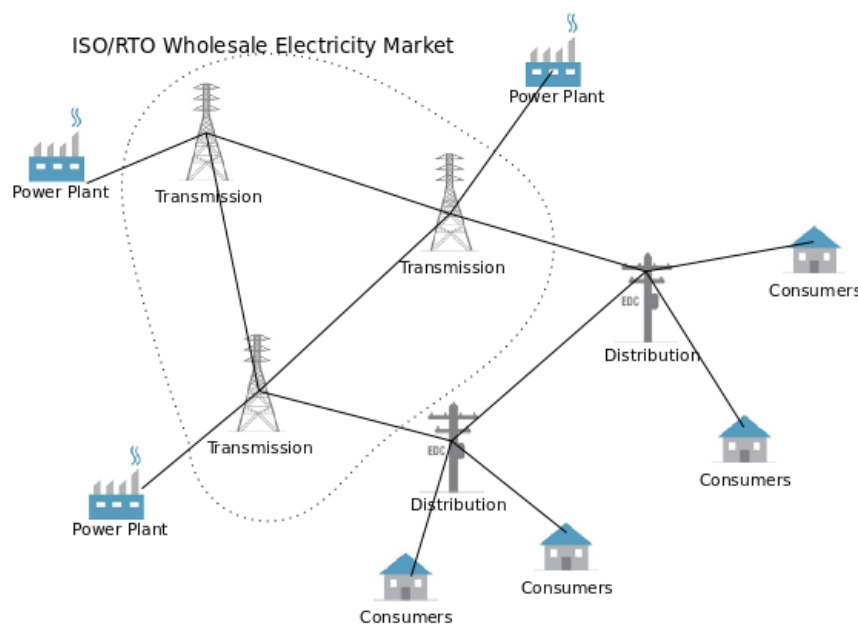

Figure 1: Electricity delivery overview

One remarkable thing about the electric grid is that there has to be a continuous balance between the amount of electricity generated and consumed at all times. Maintaining this balance is critical for the stable operation of the grid, and in deregulated electricity market, such as that in the US, this task is overseen by non-profit organizations called Independent System Operators (ISOs) or Regional Transmission Operators (RTOs) [1]. RTOs, such as the PJM RTO operating in the eastern region of the US, achieve the long term, short term and real-time energy balance by operating a three-tier wholesale electricity market consisting of the capacity market, energy market and the ancillary services market [2]. The capacity market helps procure enough generation capacity in

advance (e.g. 3 years in PJM) to meet the future load with adequate reserve to ensure reliability. The energy market helps achieve rough energy balance for each hour of the day. The ancillary services market, which contains the regulation market is responsible for ensuring real-time energy balance. Participants in the regulation market who win the bid are required to vary their generation in response to a dynamic signal sent by the RTO so that the energy balance can be maintained in real time.

There has been a recent trend in allowing large commercial customers or private entities acting on behalf of residential customers (such as aggregators) to bid into these markets by offering to change the end-use consumption for a price. This allows them to effectively act as a supplier in the market, and are termed demand resources; and the act of changing the load is called demand response (DR). For a demand resource to participate in the energy and the capacity markets, it needs to be able to reduce the power consumption on-demand, whereas to participate in the regulation market, the power consumption of the demand resource needs to be varied continuously following the regulation signal sent by the RTO. Participating in the wholesale market as a demand resource has become a viable business opportunity and has spurred research on many different DR programs. The dissertation presents novel algorithms and tools to enable residential buildings to participate as demand resources on such markets.

1.2 Motivation

Residential sector consumes 37% of the total U.S. electricity consumption [3]. A recent consumer survey showed that 88% of consumers are either eager or supportive of advanced technologies for energy efficiency [4]. This indicates that residential sector is a very good target for DR services.

There are two common solutions for load reduction DR implementation in the residential sector. First is the direct load control in which a DR service provider remotely turns off or cycles customer's power intensive equipment (usually HVAC or water heaters) to provide load reduction DR. While this scheme is simple in implementation, customer participation is not encouraged as participating customers have no control over the acceptable level of load control, which may cause customer discomfort. For example, the HVAC might be turned off for very long time during a hot summer afternoon resulting in unbearable temperature. The second common DR scheme is dynamic pricing schemes in which customers pay variable rates for electricity at different times. The theory is that customers are encouraged to shift their electrical consumption from peak time to off-peak time, thereby reducing the load at peak times. However, since most residential buildings typically lack an automatic energy management system, adjusting end-use consumption thus solely relies on manual human engagement and understandably has a lack-luster performance. So, there is a clear need of DR programs targeted at residential HVACs that works efficiently and automatically without much of a consumer engagement.

Many of the existing research work on the regulation DR focuses on commercial building control, such as varying the power consumption of the commercial AC with variable frequency drive. Residential HVACs have a much lower power consumption and do not have variable frequency drives, so cannot provide regulation service independently. However, if large number of residential HVACs are aggregated together, and if we could cycle them intelligently so that their collective power follows the regulation signal, it may be possible to participate in the regulation market. This dissertation presents an algorithm to do just that.

The process of finding good DR schemes involves testing out different ideas. While researchers have been able to test out simple ideas by writing custom programs or adapting readily available distribution system simulation software, a dedicated simulation tool for DR is invaluable for comprehensive DR research studies. While some of the available simulation tools designed especially for DR (details on the literature review section) are lacking in detailed modeling for residential buildings, the other simulation tools that have detailed residential modules are lacking in customizability in implementing custom DR. As such, there is a clear need of a comprehensive DR simulation tool for detailed study of residential DR that allows flexibility in implementation.

1.3 Objectives and Scope of the Work

In order to address the needs identified in the motivation section above, this dissertation has identified two broad objectives:

Objective 1: To Develop a Set of Algorithms for an Effective DR Program for Aggregated HVAC Control that Respects Customers' Comfort Requirements

In the residential sector, HVAC alone consumes almost 22% of the electricity [3], and because of the inherent thermal energy storage characteristic of HVAC units, they are excellent candidates for DR. Unlike the control of other household appliances, such as dishwashers, clothes dryers or clothes washers, where their starting time can be delayed, the control of HVAC units involves continuous cycling the units while taking care of the indoor air temperature. Because of the complexity of their control, this work focuses on development of a set of novel DR algorithms for controlling the operation of HVAC—the most energy-consuming appliances in a residential house. The algorithms are designed from the perspective of an aggregator to control a group of residential customers.

The algorithm will be focused on two kinds of DR services:

a) Develop an Optimal Load Reduction DR Algorithm

ISOs allow DR participants to bid into a capacity market or a reserve market with the amount of power they can guarantee to reduce when called for (called load reduction DR event). The objective is to develop a set of algorithms that lets an aggregator find the maximum aggregated load reduction achievable by controlling a group of HVACs and also mechanism to optimally control those HVACs to keep their aggregated power below a demand limit level.

b) Develop an Optimal Regulation DR Algorithm

ISOs also allows DR participants to bid into a regulation service market, where participants bid the amount (in MW) of regulation service they can provide. If participants win the bid, their consumption will need to be controlled to follow a reference regulation signal dispatched by the ISO. The objective is to develop a set of algorithms to determine the maximum regulation capability and the corresponding mechanism for controlling the aggregated HVAC power consumption to follow a regulation signal.

Objective 2: To Develop an Extensible Residential DR Simulation Framework

The second objective involves the development of an extensible DR simulation framework, especially written to support evaluation of various residential DR algorithms that can be used by other researchers and implemented as a python library. This allows researchers to import the library and use it in their work with minimal additional coding while enjoying limitless extensibility. The DR simulation framework supports the residential building module with built-in HVAC and various appliance modules such as clothes dryer, water heater, dish washer and clothes washer. It also allows injecting input data such as the outdoor temperature and solar insolation. The modules is developed to follow object oriented design allowing inheritance and function over-rides. Also, a DR aggregator module, with built-in DR algorithms support is developed as a part of this objective.

1.4 Tasks and Contributions

In order to achieve the aforementioned objectives, the key tasks accomplished are summarized below together with the identified contributions of each task.

Task 1: Develop Optimal DR Algorithms for Controlling Aggregated HVAC Loads

It involves completing the following sub tasks:

- a. Develop an algorithm to determine the maximum demand reduction potential for an aggregation of residential HVACs while the temperatures are maintained within preset upper and lower temperature boundaries.
- b. Develop an optimal algorithm to control those HVACs so that their aggregated power is kept below a limit while the temperatures are maintained within preset upper and lower temperature boundaries.
- c. Develop another algorithm to determine the maximum regulation service that can be implemented by controlling aggregation of residential HVAC units while respecting customers' comfort requirements.
- d. Develop associated algorithm to control the group of HVACs such that the aggregated power follows the reference regulation signal most closely

And the contributions from the optimal load reduction solution are:

- i. A novel algorithm to find the maximum load reduction potential for an aggregation of houses such that the temperatures are maintained within desired range.
- ii. Associated algorithm to optimally control the HVACs in those houses such that their aggregated power is kept at the minimum value while the temperatures are maintained within desired range.
- iii. HVAC control problem is transformed into an intuitive form of Job scheduling problem which provides theoretical clarity to the problem.
- iv. The optimality of the proposed algorithm is analytically proven.

The contributions from the regulation DR solution are:

- v. Theoretical proof for why universal optimal regulation algorithm cannot exist is presented.
- vi. A complete framework for implementing residential HVAC control based regulation service for demand aggregators, including the process of determining the regulation capability is presented.
- vii. A set of real-time heuristic algorithm is derived for controlling the set of HVAC to closely follow the regulation signal that has good performance on wide range of real-world regulation signal

Task 2: Develop an Extensible DR Simulation Framework

This can be divided into the following sub tasks:

- a. Develop a detailed residential building thermal model and HVAC model based on physical equations.

- b. Develop a DR authority module to dispatch DR signal to the group of houses.
- c. Develop physical appliances models for various appliances with realistic schedules and power consumption profiles and incorporate into the residential module.
- d. Develop a DR aggregator module that communicates with a DR authority to receive a DR signal and can control appliances in the houses accordingly.
- e. Formulate probabilistic usage schedules for the appliances which preserve the aggregated load shape for these appliances.
- f. Design object oriented architecture for the simulation framework which makes modification and extension easy and intuitive.
- g. Encompass all the above models into a comprehensive residential building simulation framework that is extensible and allows testing with any custom DR schemes.

The contributions consist of:

- i. An open source customizable DR simulation framework, including residential appliance-level modules, that can be used for studying residential building control-based DR. The DR simulation framework is made publicly available in GitHub.
- ii. The whole DR simulation framework is developed as a Python library, comprising the detailed house thermal model, a wide range of controllable appliance models, and a DR aggregator. Hence, any aspect of the framework (e.g., HVAC operation, DR algorithms) can be modified.
- iii. Agent-based approach is used in the design of the simulation framework, which enables close semblance with reality and facilitates easy extension of features and behaviors.
- iv. The developed framework also allows researchers to compare and evaluate different DR algorithms for load control and regulation services.

Task 3: Perform Simulation Studies to Evaluate the Effectiveness of the Developed DR Algorithms and the DR Simulation Framework

The task can be divided into:

- a. Perform a simple base case simulation and validate the simulation models against a standard building simulation tool
- b. Validate the proposed load reduction DR algorithms by running simulations over hundreds of houses to ensure that the aggregated power is kept below the minimum demand limit threshold
- c. Validate the regulation DR algorithm by running simulations over hundreds of houses to ensure that the aggregated load profile follows the reference regulation signal closely

- d. Implement reference DR algorithms, such as direct load control for HVACs and water heaters, and/or delayed start time for other appliances, to ensure that the proposed framework behaves as expected to control the residential end-use appliances and test their effectiveness in providing DR services
- e. Analyze the impact of different constraints (such as acceptable temperature range, minimum compressor ON times etc.) on the DR capability

Contributions from this task are:

- i. The proposed algorithms and the DR simulation framework is validated for correctness of operation.
- ii. Provides an insight into the efficacy of the proposed aggregated HVAC control algorithm in providing load reduction DR and regulation services.
- iii. Impact of various constraints on the DR capability is better understood.

2.0 Literature Review

In this section, a comprehensive literature survey is conducted. First, a big picture overview of DR and various kinds of existing DR algorithms and programs are presented. This is followed by literature survey of DR specially targeting residential sector and HVAC control. Finally, the knowledge gaps are identified and discussed.

2.1 Demand Side Management and Demand Response

DEMAND side management is an alternative to achieving energy balance in the electric grid by means of altering electrical demands to suit available supply, as opposed to changing the supply to meet the demand. Historically, demand side management has been used for long term energy balance through energy efficient appliances, financial incentives, consumer education and government regulation [5].

The early concept of demand side management (DSM) for the electric grid was formalized in the 1980s [6]. During that time, DSM was basically treated as a tool for utilities to influence the load shape, both seasonal and daily. Utilities were interested in fulfilling load shaping objectives such as valley filling (encourage more loads during the valley period), peak clipping (discourage loads during the peak hours), load shifting (encourage loads to shift from peaks to valleys), strategic load growth or conservation (encourage load growth or conservation in a way that facilitates flatter load shapes) and flexible load shapes (encourage loads that are flexible in their reliability requirement which means they can be shut off if required).

DSM then evolved to incorporate load profile management through energy audits, direct load control and subsequently real time pricing [7]. Demand response (DR) is one method of demand side management where end-use electricity consumption changes in short period of time (in the order of seconds to hours) in response to changes in electricity price or to alleviate system stress condition [8].

DR is either initiated at ISO/RTO level, called the wholesale DR or at a utility (Load Serving Entity or Electric Distribution Company) level, called retail DR.

2.1.1 DR at the Retail Level

At retail level, DR can be broadly classified into two groups, incentive based and price based [9], each of which is described below:

a) Price Based DR

In price-based DR, the end use customers' change in consumption pattern is achieved via variable pricing mechanism. Their eventual motivation is the reduced electricity bill at the end of the month. Some common forms of price-based DR are:

Real-time Pricing (RTP)

In this scheme, the end use customer simply is billed using a time varying price, that mirrors the wholesale price of electricity. The price might also reflect the distribution system constraints. It is expected that the customer will shift their loads so that they increase their consumption during low price period and decrease consumption during high price periods, at which time, the system is usually more stressed. Real time price varies in the order of 5-minutes. Currently in the U.S. market, there are two prominent RTP programs: Comed's Residential Real Time Pricing (RRTP) program [10] in the PJM ISO and Power Smart Pricing program from Ameron in the Midcontinent ISO [11]. Comed bills the customers with the real-time hourly wholesale market price (calculated by averaging the twelve 5-minute real-time prices) whereas Ameron uses the day ahead hourly wholesale market price in the MISO.

Time-Of-Use (TOU) Rates

It is similar to RTP except that the price changes are much less granular and are usually set by the utility (as opposed to wholesale market). The prices are varied between the off-peak (the night time), the mid-peak periods (the day time) and the peak periods (evenings). These type of rate plans are available from almost all utilities, especially for large customers. For example, the time-of-use pricing program from Pacific Gas and Electric utility in California provides a program where the customer can choose between two TOU schedules [12]: peak time between 4pm to 9pm on weekdays and off-peak other hours and holidays or peak time between 3 to 8pm and off peak other hours and holidays. The customer pays higher price during peak hours and lower price during off-peak hours.

Critical Peak Pricing (CPP)

CPP follows a base rate structure similar to TOU, however, during some rare system stress condition, the price can surge to very high value for a few hours. The customers aren't required to shed their load during that time, but they are highly encouraged to do so to avoid excessive charges. An example of such program is the San Diego Gas and Electric's (SDGE) Time of Use Plus program [13] where customers follow a TOU rate for most part, but on some days, called Event days, the prices will surge to high value. SDGE promises to keep the Event days under 18 days per year, and the event day lasts from 2pm to 6pm. Also, customers can have a certain base capacity, called capacity reservation, for which they need not pay the high price even during the event.

b) Incentive Based DR

Incentive based DR is based on providing some form of incentive (usually a fixed monthly or yearly rebate) for agreeing to participate in DR. The DR can either be enforced by having the DR service provider (DRSP), which could either be a utility or a CSP, directly control some of the end use devices of the customer, or by the DR service provider sending a dispatch message / signal requesting the customer to respond. There often is penalty for non-compliance since the service provider is counting on the customer. These DR operations are requested during the time of high wholesale electricity price, or when the system reliability is in danger.

Three classical examples of Incentive Based DR programs that an end user customer can sign up for are given below:

Direct Load Control (DLC)

In this form of DR, the DRSP remotely shuts down or cycles a customer's end use device (usually an HVAC or water heater for residential or small commercial customers) as needed. The customer usually has no ability to over-ride and dictate how long the device will be shut down. However, most program limit the event to a few days per year, and a few hours per event. The customer gets either one-time rebate for participating on the program or gets a bill credit. There are several DLC programs in use [14]. For example, Entergy-Arkansas has a summer advantage program that gives \$25 rebate for installation and \$25 each year for allowing to cycle the HVAC 50% less [15]. The reward is increased to \$40, if cycling is allowed to be 75% less.

Interruptible/Curtailable Load:

This is comparable to DLC in that it involves shutting down a certain load during DR need. However, this program is geared towards industrial or large commercial customers with single large loads and the DRSP doesn't directly control them. They dispatch a request in short notice, and large penalties maybe charged for failure to comply. The customer gets rate discount or bill credit for participating. The response time requirement is 20 to 60 minutes. SDGE's Base Interruptible program [16], for example, gives 20 minutes' notification time and the event lasts for upto 4 hours, with the annual total hours capped at 120 hours. The rewards is based on the amount of kW reduction and it varies from 1.8\$/kW to 10.8\$/kW based on month.

Emergency Demand Response:

In this case the customers are called by the DRSP during system emergency condition, and are paid based on the power consumption they reduce during the emergency period, and often compliance is optional.

Capacity Market DR

These programs pay a customer who pledged to reduce the demand by a certain amount whenever called for. This acts as a guaranteed load reduction capability, which helps the utility mitigate some of its capacity requirement obligation. Capacity Bidding Program of SDGE is an example [17].

By end of 2015, it is estimated that retail DR has contributed to a peak saving of 32,875 MW, out of which 8,703 MW was contributed by residential sector, 6,989 MW by commercial sectors and 17,169 MW by the industrial sectors [18].

2.1.2 DR in the Wholesale Market

In the wholesale level (i.e. at the ISO/RTO market), demand resources can provide DR service in one of the three markets, Energy Market, Ancillary Services Market and the Capacity Market [19], [20]. The following discussions are based on the PJM RTP market, but any other RTO/ISO should have similar provision.

a) Energy Market DR

In the energy market, a demand resource can participate in either the day-ahead hourly energy market or the real-time energy market. In either market, the demand resource should submit a bid for energy reduction in a given hour of the next day (for hour-ahead market) or in a given 5-minute interval, in a real-time market. This bid is treated as supply bid in the market clearing process, and should the bid clear, the demand resource is obligated to full fill the promise by either reducing the energy demand by the proposed amount, or making purchase of the energy from the real-time market if it cannot full-fill the obligation. There is a comprehensive guideline for measuring and validating the energy reduction by using consumer base load (CBL) profile. CBL is the energy consumption profile of the load under control by the demand resource, should there be no control. Any qualifying Demand resource should calculate its CBL profile based on most recent historical data and have it approved and verified by the ISO, who might routinely test it.

b) Ancillary Market DR

In the Ancillary market, Demand Resources are allowed to bid into three sub-markets to offer their DR services

Regulation Market

Regulation is a capability of either generation or demand resource to produce/consume variable amount of power as per a regulation signal. Regulation is used in the electricity grid to continuously maintain the power balance between production and consumption so that the frequency can be kept constant at 60 Hz. In order for a demand resource to be eligible to participate in the Regulation Market in PJM it must meet the following requirements:

- Be able to provide 0.1 MW of Regulation Capability
- Have a controller capable of AGC Control
- Be able to receive an AGC signal and have proper telemetry with PJM
- Pass initial Qualification test performance

The qualification test involves following a test Regulation signal for a period of 40 minutes, and evaluating how quickly and closely the resource is able to match the power consumption with that in the signal.

Day-ahead Scheduled Reserve Market

Day-Ahead Scheduling Reserve Resources comprise of all those resources that can provide reserve capability that can be fully converted into energy within 30 minutes from the request of the PJM dispatcher at the time of the request and is provided by equipment which may not necessarily at the time of the request be electrically synchronized to the system. Load response resources must be registered in the Economic Load Response program, indicate that they can be dispatchable by PJM in real-time and be able to be reduced within 30 minutes. Resources may participate and be compensated in both the Day-Ahead Scheduling Reserve and Synchronized Reserve Markets. Demand resources providing Day-Ahead Scheduling Reserve are required to provide telemetry that is capable of providing metering information at no less than a one minute scan rate. Demand resource participation will be limited to 25% of the RTO Day-Ahead Scheduling Reserve Requirement.

Synchronized Reserve market

In real-time PJM will jointly optimize the remaining RTO reserve needs simultaneously with energy and regulation and calculate a clearing price for Synchronized Reserve every 5 minutes based on the current system conditions

The MW synchronized reserve capacity of a demand response resource is the quantity of the load reduction achievable in ten (10) minutes. Demand resources providing Synchronized Reserve are required to provide metering information at no less than a one-minute scan surrounding a synchronized reserve event. Demand resources are limited to providing 33% of the Synchronized Reserve requirement of PJM system

Resource owners wishing to sell synchronized reserve or regulation service must supply an offer by 14:15 the day prior (the close of the Generation Rebidding Period); however, hourly updates may be submitted or changed up until sixty-five (65) minutes prior to the operating hour, at which time the Regulation, Synchronized Reserve and Non-Synchronized Reserve markets close.

c) Capacity Market DR

PJM Capacity Market is designed to ensure the adequate availability of necessary resources that can be called upon to ensure the reliability of the grid and will help to support infrastructure investment. As shown in figure 2 below, capacity market DR is predominant DR method in the wholesale market by revenue.

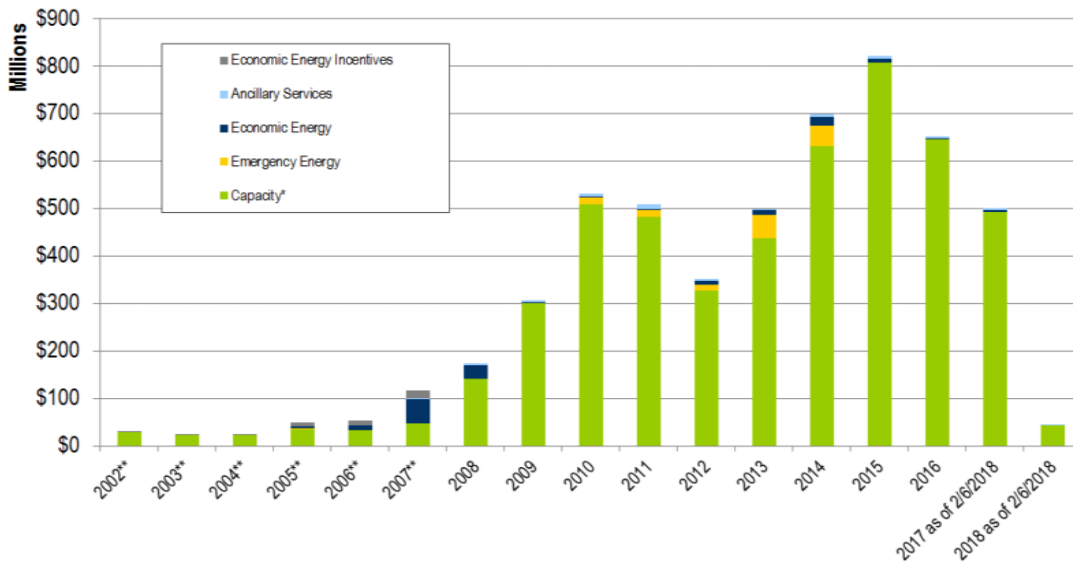

Figure 2. PJM Estimated Revenue for Economic and Load Management DR Markets

There are two markets within capacity market that a demand resource can participate in

Fixed Resource Requirement (FRR) Alternative Market

In this market, utilities can meet their capacity requirement not by buying capacity from the RPM market, but submitting its own plan capacity plan of securing those capacity. Demand resources can also participate in FRR market by providing a plan of load reduction via DR.

Reliability Pricing Model (RPM) Market

In the RPM market, electricity producers submit bid 3 years in advance to for the amount of production capacity they are willing to supply for a given price. Consumers, usually the utilities, need to submit buyer bid in the RPM market to meet their expected load in 3 years. Demand Resources can also submit bid in the RPM market as a supplier by promising a guaranteed load reduction when required to meet the capacity. This is termed as load management DR and the PJM dispatches the load management event when promised capacity is required by the system (possibly due to other power plants being shut-down or a certain transmission line being jeopardized).

There has been rapid growth of DR participation in the RPM market in the past 10 years, attributed to wider accessibility to enabling technology and lucrative capacitive market payments (see figure 3 below).

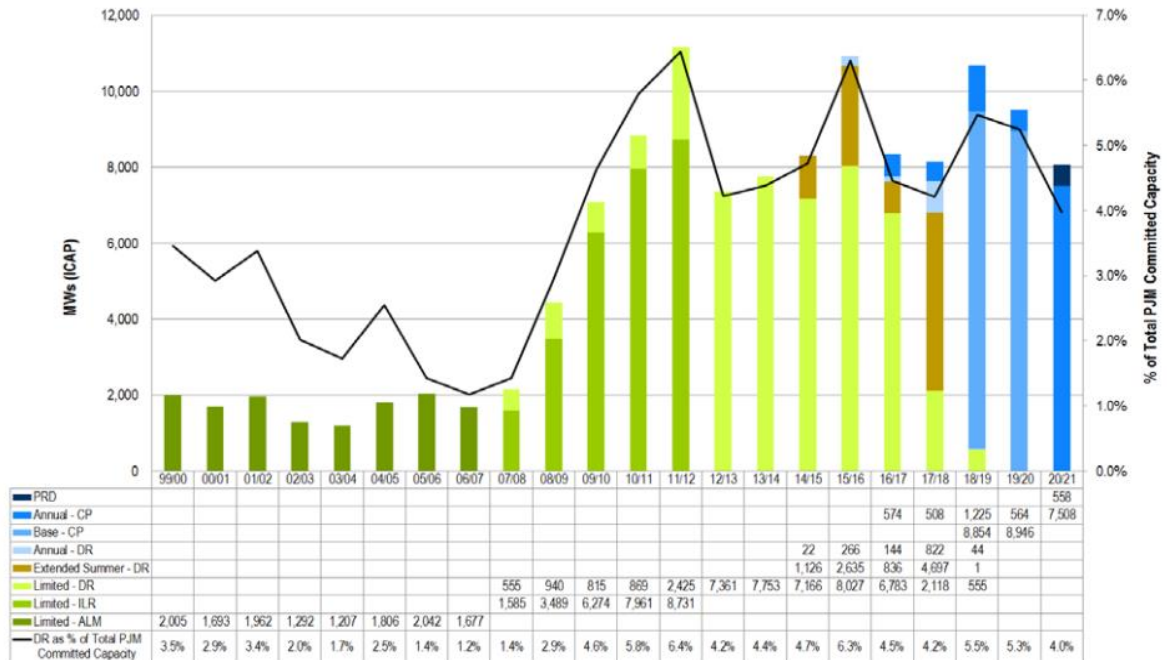

Figure 3: DR capacity commitment in the PJM market over time

Until now, demand resources were allowed to bid only as a Limited DR capability providing DR only during the summer or extended summer months, and that too with a capped interruptions of 10 per year for a limited hours of the day. Starting the year 18/19 PJM is phasing them out and starting year 20/21 all resources will be required to be enrolled as a Capacity Performance (CP) resource that is capable of providing load management any day of the year for any number of interruptions [21]. This is done in order to make it a fair competition between resources that can provided the capacity any time of the year versus resources that are available one some of the time. However, to accommodate demand resources only available for summer, PJM is introducing a separate summer period DR capacity market, that runs from May to October, and operating hours between 10:00 AM to 10:00 PM. However, the resource should support unlimited interruptions.

The table below summarizes the various DR opportunities in the wholesale market.

Table 1: Wholesale market DR opportunities

Energy Market	Ancillary Services Market	Capacity Market
<ul style="list-style-type: none"> • Day-ahead Energy Market • Real-time (balancing) Energy Market 	<ul style="list-style-type: none"> • Regulation Market • Synchronized Reserve Market (10-minute notification) • Day-ahead scheduled Reserve Market (30-minute notification) 	<ul style="list-style-type: none"> • Reliability Pricing Model (RPM) market • Fixed Resource Requirement (FRR) Alternative

By the end of 2016, wholesale DR contributed 28,673 MW of capacity in the U.S., which corresponds to 5.7 % of the peak demand [18]. It accounted for 9,836 MW capacity in the PJM ISO, in which 18% came from residential, 46% from Manufacturing and the rest from various sectors such as Hospitals, schools, retail stores etc.

Aggregators

Since the entry bar for participation in the wholesale DR market is quite high (requires considerable amount of DR capability and has to be registered as a PJM member), most end use customer need to participate via Aggregators, called curtailment service provider (CSP) in the PJM market. CSP can either be entities without any physical energy generation or consumption infrastructure, or a traditional utility (LSE or EDC) that have binding contract with a group of end-

users to represent them collectively in the wholesale market. The overwhelming majority of CSP in the PJM market are not affiliated with any LSE or EDC.

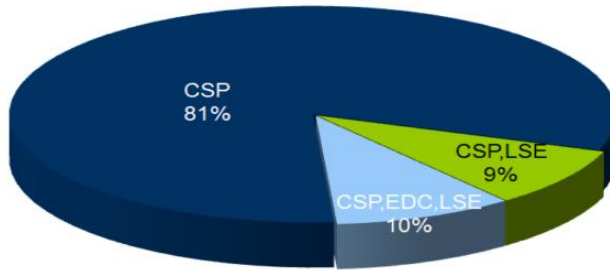

Figure 4: DR company types in the PJM market [22]

CSPs need to submit a form with the list of end user accounts registered in an EDC, the load reduction methods and the load reduction MW to enroll as a player in the Market [20]. The application will be reviewed by PJM to check their eligibility and other criteria (such as absence of double representation of same end user customer on multiple CSPs). There are close to hundred CSPs enrolled in the PJM market [23] as of 2018.

More details on DR methods can be found in surveys [24]–[26] and real-world applications can be found in [27].

2.2 DR at Residential Sector

The figure below from the PJM Demand Response report [22] shows that residential sector contributes to 18% of the total DR market in the wholesale market, whereas the data from [18] shows that it represents about 25% of DR market in the retail area.

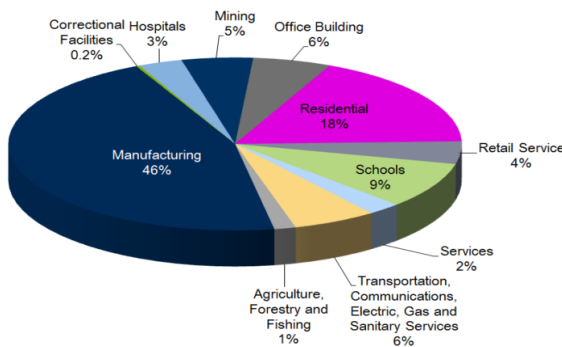

Figure 5: Contribution of various sector to the wholesale DR

However, in the US electricity market, residential sector consumes 37% of the total electricity.

U.S. electricity use by sectors (2014)

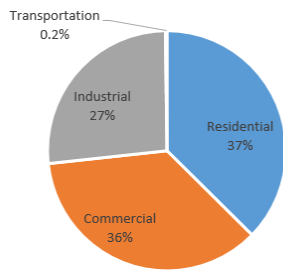

Figure 6: US electricity use by sectors

The energy consumed by the residential sector primarily go into Heating Ventilating and Air conditioning (HVAC) system followed closely by lighting and water heating requirements.

Electricity end use in U.S. homes (2014)

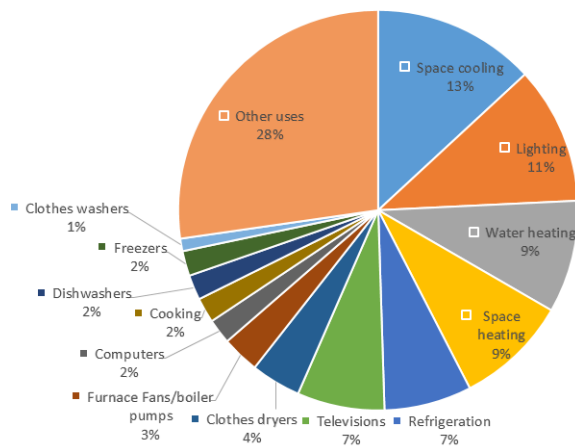

Figure 7: US electricity use by end-use types

All of the retail DR methods discussed in the previous section have been used and available in the residential sector. Because of their built-in energy storage mechanism and their large share of the household energy consumption, HVAC and water heating are the most attractive targets for DR at a residential house. In this respect, the most commonly used form of DR at residential building is DLC [14] where a cycling device installed at the HVAC device simply turns off the device at the signal from utility or DR service provider.

Except for DLC based DR where the equipment is automatically controlled by the utility, for other kinds of retail DR discussed, the customer has to use his own energy management system or manually control the loads to perform DR. And large number of research has been conducted on how to perform this task optimally, under various constraints and objectives, which will be discussed next

2.3 DR Implementations

DR implementations can broadly be classified into two groups based on their techniques: Task Scheduling based DR and Energy management based DR [24].

2.3.1 Task Scheduling based DR

The objective in task scheduling based DR implementation is to find optimal schedules for different appliances such that a power demand during certain hours is minimized. It relies on the assumption that various loads have predefined running time requirements and some of them have flexible start time requirements, so that it's possible to temporally shift some of the loads around and still meet the load requirements. Loads can be designated as either non-interruptible and non-flexible (such as coffee machine), non-interruptible but flexible (meaning the load cannot be stopped once started, but the start time can be flexible, for example washer), and interruptible and flexible (such as water heaters or EV charging). In [28] authors find best schedules for such loads to have minimum cost in a dynamic pricing scenario, whereas authors in [29] try to find the optimum schedule that reduces the peak power consumption. In [30], DR at a single house is achieved by scheduling loads according to their priority and comfort requirement.

2.3.2 Energy Management based DR

The objective in energy management-based DR is to reduce the power consumption of a particular load so that the total energy/power consumption is reduced during certain peak hours. So, as opposed to loads with flexible schedule in case of task-scheduling, it requires load with flexible consumption. For example, the set-point of a thermostat can be increased to cycle it less frequently or the brightness of a dimmable light is decreased to reduce its power consumption. Most of the HVAC control-based DR, which will be discussed later, falls under this category.

Based on the optimization objectives, DR can be divided into the following categories:

2.3.3 Electricity Cost Minimization in Dynamic Pricing Scheme

Largest amount of research work in DR is dedicated to finding the optimal schedules for running various load such that the total cost of electricity is minimized.

The generic optimization problem solved by DR schemes in this category is:

$$\min Cost = \sum_{t=0}^T P_t * C_t$$

Where P_t is the power consumption in time interval t and C_t is the electricity cost for that time. There are usually lots of constraints that defines the power profile, and the problem is to find the best scheduling in light of those constraints. For example, authors in [31] find the optimal schedule for a set of appliances in a house with a RTP scheme, such that the peak energy on any hour is kept below a threshold and the total cost is minimized, while respecting the start and end time restrictions of all the appliances. Similarly, in [32] uses price and consumption forecast of a water-heater load to help with the scheduling and minimizing cost.

In [33], in addition to cost minimization, consumer dis-satisfaction minimization is also explored.

In [34] solve the optimal DR as a unit-commitment problem of minimizing the cost associated with operation, reserve and expected load not served.

In [35], renewable energy generation and battery energy storage is added in the problem. The appliance binary status constraint is relaxed using regularization technique to make the optimization problem more tractable in [36].

All of the above mentioned research uses a complex convex optimization formulation to find the optimal schedule, which might be time consuming and inefficient for large problem size. In [37] evolutionary algorithm is used to find the optimal load shifting strategy to find the load curve that matches the objective curve such that the cost is minimized. [38] presents an efficient minMax scheduling algorithm that is shown to provide near-optimal solution to cost minimization on dynamic pricing scheme for a household.

2.3.4 Maximization of Social Welfare

Another class of research work in DR is focused on maximizing the social benefit, which is defined as the benefit remaining after subtracting out the utility's cost of generation and transmission from the profit made from charging energy cost to the customers. This form of objective inevitably requires taking into account a collection of customers as well as consideration of generation cost as a function of energy demand. [39] presents an efficient pricing algorithm so that participants are forced to act in a manner that maximizes the social welfare. The algorithm works because each participant is assumed to try to maximize their own benefit, but the mechanism is cleverly designed such that the social welfare is maximized when that happens.

In [40] two period electricity market and uncertainty in renewable energy generation guide the optimal pricing scheme to be used in real-time market to achieve demand response that maximizes the social benefit.

In a more recent work [41], the aggregated control of group of thermostatically controlled loads (TCL) is formulated as a mechanism design problem for maximizing the social welfare. Each consumer is assigned a comfort function that depends upon their energy use, and are expected to bid their price vs energy requirement in the utility level market. The mechanism forces each user to bid their true function to maximize their individual utility, but under certain assumptions, it also leads to maximum social utility.

2.3.5 Minimization of Power Consumption

The minimization of power is achieved by finding optimal schedule for running appliances, similar to minimizing cost, but there is an absence of a price signal, but instead a distinct objective to reduce the peak power or power during certain hours. In [42] authors uses ILP to solve scheduling problem for a house with shiftable and non-shiftable appliances so that the hourly total power for all the hours is minimized while meeting the appliance energy requirement. In [43] each controllable load groups (AC, pool pump) have predefined pay-back patterns and authors use LP to find the optimal set of load control strategies for different groups to minimize system peak.

2.3.6 DR Implementation Targeting HVAC control

Since HVAC constitutes the largest electricity consumption device in buildings, it is the focus of this research work. (Parts of the literature review in this section has been borrowed from my previous publication [44].)

Direct load control [45] is one of the most popular method of demand response for the residential sector [46] where a utility can remotely turn off (and then turn on) a consumers electrical equipment during the time of system stress. As per the classification in [24], this can be classified as incentive based centralized demand response. Several approaches can be found in the literature for this form of control. The most primitive one is to just turn off the appliances during the critical period disregarding any customer preference or comfort. We will review some of the literature on HVAC direct load control strategies which attempt to take customer comfort and preferences next.

In the literature on smart DLC for HVAC, authors in [47] and [48], divided HVACs crudely into different groups based on their comfort requirements and building thermal characteristics, and applied some empirical fuzzy rule [47] or predictive control [48] to control the duty-cycle for each group during the direct load control period. While, this can result in load reduction, while having some degree of customer comfort, this method neither explicitly takes care of each customer's

comfort requirement, nor achieves optimal load reduction. Authors in [49] use peculiar chilled water thermal storage capacity to offer DLC in commercial buildings, which cannot be generalized for the residential settings. In [50] adaptive control based DLC is explored where a power reduction requirement is converted to set-point change requirement to feed into a classical thermostat based controller. While this system enables power-reduction to a desired level on aggregate but it is not optimal. Also, there is no way to determine the maximum allowable power reduction. The study shows a simulation result where the power has been successfully limited to 100 kVA (which is 10% lower than before the control, and is arbitrarily chosen) of the original peak but whether that is the maximum reduction attainable is unknown. Similarly arbitrary change of temperature set-points are shown to achieve some arbitrary reduction of power consumption during a critical period in [51]. In [52] double auction based transactive control is used to set-up a capacity market to limit the aggregated HVAC power. However, the power limit imposed is arbitrarily chosen and the transactive control used may not be optimal to control the population of HVACs. In [53] dynamic price based transactive control is studied for its efficacy in reducing the peak. But the price signal used is arbitrarily chosen and the reduction attained is far from optimal. Our work on transactive control [54] shows that a simple price signal based transactive control can reduce load during a high price period but creates a restrike after the event.

There are substantial number of research work on optimal demand response [55][56][35][38][57][58], but they mainly focus on task scheduling based demand response, where several house-hold appliances are assumed to have either a total running time requirement or energy consumption requirement, along with their power requirement, and an optimization problem is solved for each house individually, to calculate the optimal schedule for each appliances to incur minimum cost to the household. This only addresses scenarios where the buildings are concerned about their cost minimization in the presence of an upstream real time price, and the presence of other households trying to do the same thing has no effect on the solution. However, the objective of this dissertation is to find optimal direct load control, where we want to reduce the maximum possible load, for a collection of houses (not individual), during a control period; taking into account only the consumer comfort requirement. [55] indirectly addresses this problem by setting the upstream price to be function of the aggregated power, hence taking into account the aggregated dynamics; however, it is still based on primitive task-scheduling, and as such doesn't take into account the fine dynamics of TCL. In [57] the TCLs thermal dynamics are incorporated, but it doesn't explicitly takes care of the comfort constraints. Also, it ignores the aggregated dynamics since it relies on a fixed upstream price for solving the optimization problem. [58] applies learning algorithm to establish relationship between setpoints, outdoor temperature and other variables and the energy consumption to help with scheduling. This avoids having to do thermal simulation. [59] takes TCL dynamics into account and optimizes for cost reduction based on dynamic price, but it disregards aggregated behavior. None of these optimal DR consider TCL dynamics, user comfort constraints and aggregation effects all together.

There is also research work that specially targets aggregated control of HVAC or thermostatically controlled loads (TCL). In [60] probabilistic aggregate model of a collection HVAC system is developed, that explicitly takes compressor off times into account, and its application on power reduction is explored. It roughly achieves power limit within the reference, and temperatures within the range, but since it is based on probabilistic method, the aggregate power frequently exceeds the reference and also the temperatures of some buildings exceed the constraints (especially when compressor cannot be turned on because of time-delay constraints) In [61] an aggregated model is developed for HVACs and their potential for load following is explored. HVACs are controlled based on priority established by calculating temperature distance from the boundary. Authors in [62] develop a similar approach for water heater control.

In [61]–[65], aggregated model is developed for Electric water heater or HVACs and are controlled based on priority established by calculating the temperature distance from the boundary. Although, the control method employed is intuitive for minimizing the switching requirement, its optimality is not proven. [64] Converts HVACs into generic second order continuous time TCLs and creates a aggregated battery model to study the collective behavior on average, but it cannot take into account instantaneous co-occurrence event of different HVACs. [66][67][43] Look at aggregated control of appliances through optimal scheduling to reduce peak power and flatten the load curve, but they ignore the peculiar TCL dynamics.

In [68], an iterative demand bidding is used to arrive at an optimal schedule of customers so that their collective utility is maximized—but there is no direct control on the amount of power reduction and might take long time for the iterative bidding to stabilize and deliver HVAC control schedules.

In more recent works, an aggregated model of AC has been developed and an optimal DR based on dynamic programming that respects comfort constraints has been proposed in [69]. Similarly, aggregated control of residential HVAC for peak load shaving has been explored in [70] and optimal DR using MPC approach can be found in [71]–[73]. In [74], authors present mechanism for optimal scheduling of smart appliances in the context of a smart community for the purpose of peak load reduction. Transactive control based DR is explored in [75]. A generic modelling technique also applicable to HVAC for fast-acting DR can be found in [76]. However, all of these research is concerned with optimal DR in presence of an upstream price signal or by creating various pricing scheme, which is not applicable to the problem being explored. In [77], aggregated control of HVAC for frequency regulation using a sliding-window based control is explored while their control for load balancing service is explored in [78].

In the area of DLC for HVACs for peak shaving, recent work close to the one proposed in this dissertation can be found in [79]. While authors in [79] minimize user comfort violations by doing a fair allocation of the comfort violations to reduce the peak load by an arbitrarily set amount, this work aims at meeting the user comfort requirement (that the user agreed to in the contract), and achieving maximum attainable load reduction.

2.3.7. DR implementation for providing regulation services using HVAC control

A regulation service requires participants to vary their generation (or consumption in the case of a demand response (DR) resource) in response to regulation signals dispatched by RTO. Two kinds of regulation signals are available in the PJM market: the slow changing traditional regulation signal (RegA) and the fast changing dynamic regulation signal (RegD). Participants can bid the amount, price and type of regulation services (RegA or RegD) for each hour of the next day. And, if they win the bid, they are expected to adjust their generation (or consumption) to closely follow the regulation signals during that hour.

One type of participants for a regulation service is a DR aggregator who aggregates at least a certain amount of building-level loads (e.g., at least 0.1MW for PJM) and control them to make the aggregated power follow the regulation signal. Typical building-level loads that can be aggregated/controlled are a group of residential Heating, Ventilation and Air Conditioning (HVAC) units. Aggregated control of HVACs has a number of unique challenges. First challenge comes from the requirement to keep the indoor temperature of each house within an acceptable homeowner's comfort range. This constraint forces HVACs to turn ON or OFF to maintain the indoor temperature around the pre-set set point (e.g., 77°F). And, with simultaneous operation of many HVACs, it will create inadvertent and large aggregated power fluctuation that interferes with the objective of controlling their aggregated power consumption. The second challenge comes from the fact that AC compressors cannot be cycled very quickly due to their built-in protection mechanism to ensure the minimum amount of time an HVAC is turned ON. This poses a challenge in controlling the aggregated power of HVACs to track fast moving regulation signals.

To tackle these challenges, methods to control a group of HVACs have been discussed in the literature. In [80], researchers have presented a mechanism (called safe protocol) to produce positive and negative power pulses without disturbing the state diversity and creating peaks due to inadvertent synchronization. In [81], the authors propose a temperature priority-based algorithm to control an aggregation of HVAC units for load following where compressor lockouts (because of the minimum ON/OFF time constraint) are taken into account. The work is extended in [82] to take into account the thermal behavior variations among different houses. The work however was done using a one-minute signal as opposed to the two-second regulation signal. Also, the HVAC rated capacity has been assumed to be the same for all houses. The weighted minimization problem of difference between wind power and residential demand and between desired temperature and actual temperature is explored in [83]. However, the model assumes continuous variability of HVAC power. It also ignores minimum ON/OFF time requirements or problem of inadvertent synchronizations. Authors in [84] have added frequency control into a simple dead-band based HVAC control as a means to provide frequency response to the Great Britain grid. The work disregards hard temperature limits and the aggregation effect is not

properly tackled to make the power follow a regulation signal. Authors in [85] present a state-space model for aggregated HVAC control that can be used for load following. However, it is a simplified aggregated model that does not consider individual HVAC dynamics and minimum ON/OFF time requirements. In [86], sliding mode set point change-based controller is used for making an aggregated HVAC power follow Automatic Generation Control (AGC) signals. The meta-heuristic natural aggregation algorithm is used to solve the HVAC status scheduling problem for load-shape modification and cost-minimization in [87]. But the approach is only applicable for cases when the aggregated HVAC power needs to follow a known power profile, which is not the case for constantly changing regulation signals.

Some work has also been carried out in the area of commercial HVAC control. Their use in regulation services has been explored in the case with variable and controllable fans [88][89]. A decentralized control algorithm for HVACs for load-shape management is explored in [90] and a partial differential equation-based aggregated model incorporating set-point change is developed in [91]. However, these aggregated mathematical models do not consider individual compressor ON/OFF time requirements. While commercial HVACs have clearly been identified as a great resource for regulation services [92], the residential sector on the other hand provides untapped demand-side resources and is expected to contribute significantly in the regulation market of the future [93].

The work most closest to the one propose in this dissertation is found in [94] where the AC compressor's minimum ON/OFF times are explicitly modelled in the state-space model. Authors tackle unpredictability of regulation signal by maximizing the 'regulation capacity', defined to be proportional to the number of unlocked HVACs. The state queuing model employed, however, has been shown to be not very accurate [95].

2.4 Residential Building and HVAC Control Based DR Simulation Tools

Research work on residential building HVAC control requires the use of tools that can simulate the building thermal dynamics and the HVAC power consumption to fairly accurate degree and allow for implementing control strategies. Next some of the popular candidate tools that for residential thermal dynamics simulation and HVAC control are presented.

EnergyPlus [96] (currently version 8.8.0) is one of the most popular and comprehensive building simulation tool available for free. The strength of EnergyPlus lies in its capacity to consider detailed thermal model of building as well as detailed HVAC equipment models. In addition to HVAC and thermal simulation, it can also do illuminance and lighting simulation. It's mainly geared towards accurate energy consumption modelling and helping designers find the pros and cons of particular design element on the energy consumption. Although it can do sub-hourly

simulation, the HVAC system is modelled using part-load curves and does not simulate the dead-band based control [97], [98]. Although this modelling approach is adequate for energy consumption analysis, it is not suitable for studying the impact of a demand response algorithm that relies on modifying the dead-band based control algorithm. EnergyPlus provides its built-in EMS scripting [99] platform and external interface [100] to Building Controls Virtual Test Bed (BCVTB) [101] for user defined control . While BCVTB opens up lots of possibility, the built-in EMS scripting is quite limited. However, due to EnergyPlus's inherent limitation of thermal simulation using part-load curves, a more nuanced HVAC control cannot be implemented either-way.

Other similar tools for building energy simulation such as DOE-2.2 [102], [103] and simulation environment based on it, the QUick Energy Simulation Tool (eQuest) [104], can perform similar energy consumption analysis, but they are restricted to hourly interval and are inadequate for dynamic HVAC simulation.

There commercial software such as TRNSYS [105] and IDA ICE [106] that can perform detailed multi-zone thermal simulation of buildings and have comprehensive and easy to use library of HVAC devices. However, they are proprietary and have limited capability for customization and user defined control.

All of the building simulation software discussed are geared towards single building simulation, and cannot be used for studying DR when a population of buildings are controlled. Distribution system simulation software such as openDSS [106] and PowerFactory [107] while adequate to do a basic DR study involving load reduction, are inadequate for studying a detailed HVAC control based DR that relies in building thermal simulation. In this respect, GridLAB-D [108], [109] , a distribution system simulation tool, with its residential thermal model is the only available tool for studying large-scale HVAC control based DR. There are built-in controllers that can perform common DR operation, such as transactive control [54], [110], [111] or a simple load reduction based on set-point increase at a pre-defined time. Though GridLAB-D supports user customization through external interface [112], the capabilities are limited by what internal variables GridLAB-D exposes and other immutable operating characteristics of built-in model (such as minimum requirements for dead-bands).

There are a few simulators specially targeting for DR. Multi-agent based simulation framework is proposed in [113] for performing city-wide DR simulation. The framework supports entities like Households, Appliances, Vehicles, Power Stations and Cities. The appliances are modelled using simple ON/OFF schedules with fixed power consumption.

A simple DR implementation software that performs a cost minimization optimization is proposed in [114]. The software models air conditioner as capable of running at three distinct power levels as a means of accounting the duty cycle changes. Then it finds optimum schedules for the appliances so as to meet their requirement as well as minimize cost .

Demsi [115] is a demand response simulator geared towards studying the impact of Distributed generation in the distribution network and the capability of DR in assimilating them. Loads are just classified as critical or flexible and lacks detailed modelling.

In [116] authors propose a DR analysis software that generates appliance and house type distribution pattern based on the census data. It can help study large-scale impact of certain simple DR strategy based on simply turning of some categories of appliances, but is inadequate for a more complex DR as it lacks appliance physical models.

DRSim [117] is DR simulation framework that takes into account historical usage data to predict appliance usage patterns. It defines three types of agents: house agent, appliance agent and human agents and uses probabilistic modelling to simulate the impact of humans on the appliance. However, it is focused on a single house, and considers only human-controlled appliances with fixed power consumption. As such, it lacks detailed physical appliance models.

The SMASH (SiMulated Adaptable Smart Home) simulation platform proposed in [118] uses a three layer architecture consisting of physical layer, monitoring and controlling layer and the reasoning layer. This facilitates a cleaner and safer DR control algorithm integration. Unlike other DR simulation tools, SMASH does take into account the indoor temperature, however it uses a simple first order model and provides limited capability of controlling the HVAC operation. Also, it is focused on a single house and lacks the capability to perform large scale multi-house simulation as it follows time-step based approach.

2.5 Knowledge Gaps

The literature review in the preceding section points to knowledge gaps and research needs in three key areas:

2.6.1 Optimal Aggregated HVAC Control DR Algorithms

Although there is abundant research that considers HVAC thermal dynamics and user comfort constraints for aggregated HVAC control, there is no research work that looks at the problem from first principle and intuitive angle. Most of the research work formulates an optimization

problem after making some simplifying assumptions and focuses on finding a solution using standard techniques. A deeper look into the exact limitation and intuitive problem formulation is lacking.

In respect to load reduction DR, existing research work seems to arbitrarily choose a load reduction amount and demonstrate that whatever control algorithm proposed can meet the load reduction requirement. No attempt has been made to find the maximum attainable load reduction in light of customer comfort constraints.

Similarly, for a regulation service-based DR for an aggregation of HVACs, existing research work shows acceptable load following result when temperature set-points of thermostats were controlled based on the load following signal. However, no attempt is made to find out the maximum attainable regulation capability nor optimal control strategy for regulation.

2.6.2 Extensible DR Simulation Tool with Detailed Residential Module

Even though there are many high quality building simulation tools, due to the lack of full customization capability and because of focus on single building, they are inadequate for studying DR.

While many distribution system simulation software tools exist, most of them focus on aspects of distribution system such as distribution lines, transformers, capacitors, and voltage stability and do not have a detailed residential module. This renders them useless for studying DR based on residential building control. One notable exception, GridLab-D, does have a detailed residential module. However, because of the closed nature of the software and limited user customization capability, it is very hard to use Gridlab-D to study all but the simplest kinds of DR implementation.

There are other tools recently developed specially for DR study which have residential modules composed of various appliances. But most of them use simple appliance schedules and do not model the house thermal dynamics governing HVAC operation. While they are useful for studying simple DR schemes such as priority based appliance scheduling, the lack of thermal model renders them almost useless for HVAC control based DR. Some of the platforms are focused on DR at a single building, so even if they had a proper HVAC model, they would not be suitable for studying aggregated HVAC control based DR.

Hence a proper DR simulation tool that can facilitate the study of aggregated HVAC control based DR is clearly lacking.

3.0 Methodology

Formal definition of the problems and the details of the proposed solution to meet the objectives of the dissertation is presented in this section. First, the algorithm for optimal load reduction DR is presented, following by the problem definition of the algorithm for optimal regulation DR. Finally, the structure of the residential DR simulation framework is explained in terms of simulation technique, house thermal model, and appliances models.

3.1 Optimal Aggregated HVAC Control DR Algorithm

3.1.1 Optimal Load Reduction DR Algorithm

(Parts of the methodology in this section can match with my previous publication [44])

a) Framework and Problem definition

Consider that N residential customers, which can be spread among different distribution network or be on the same network, have signed up with a DR aggregator such as EnerNoc. The aggregator can perform collective control of these customers to provide load reduction DR service to the utility or it can bid this demand reduction potential into a capacity market [119]. It must not be very difficult to find willing customers for the program as there are already customers who are participating in traditional HVAC direct load control programs where they consent to let the utility remotely turn off their HVAC for a fixed duration of time (without regards for the indoor temperature) in exchange for some rebates. At the minimum, those customers should be willing to participate in the proposed form of DR which guarantees that the temperature will always be maintained within a pre-agreed upper and lower threshold. The overall framework is illustrated in Figure 8, where the aggregator has established communication link with an IoT-based thermostats in each of the N houses. There is also a conceptual controller assigned for each house. Although the controller logically belongs to the house, it can be implemented as an independent agent at the aggregator.

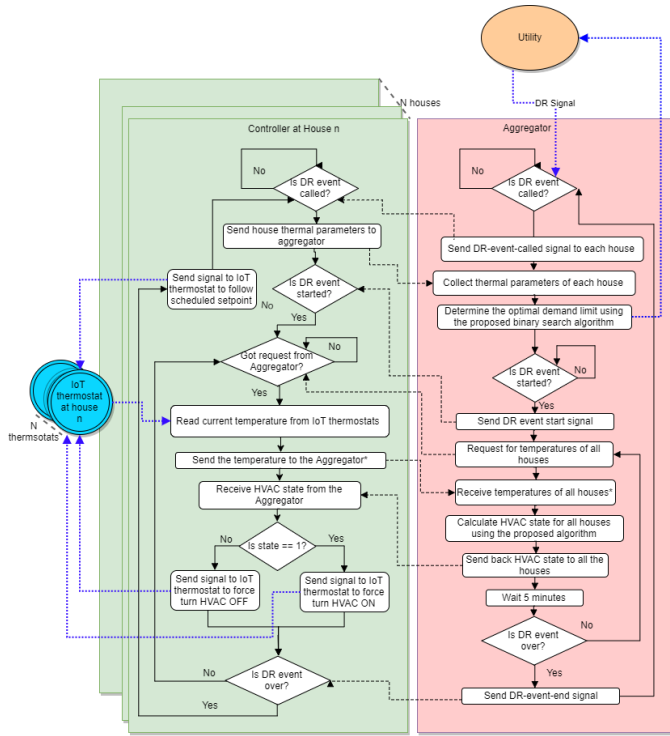

Figure 8: Framework for optimal DR

When the aggregator receives a signal from the DR authority, which could be a utility or an ISO, it sends a DR-event called signal to the house controllers and asks for the house thermal parameters and customer's preferred temperature boundaries. The controller can estimate house thermal parameters based on known properties (such as, floor area, insulation types, etc.) or from house thermal response using maximum likelihood based estimator [120]. The aggregator then uses the binary search algorithm (discussed in Section III(A)) to determine the optimal demand limit (kW) which it can then report to the utility.

At the time for DR event, the aggregator dispatches a signal to each house-controllers and the controller enters DR mode. At the beginning of each subsequent control interval throughout the DR event, the aggregator requests for the internal temperature of each house by communicating with the house-controller which in turn communicates with its respective IoT-based thermostat to get the current temperature and calculates the time for the temperature to hit the comfort limit. The house-controller forwards this temperature and the time it will take for the temperature to hit the comfort boundary to the aggregator.

After receiving the information from all houses, the aggregator calculates the optimal HVAC state for the current control period for each house using the proposed greedy algorithm (discussed in Section III(B and C)) which it sends back to each controller for execution. The house-controller then maintains the HVAC state as OFF or ON for the duration of the current control period based on the state assigned. Contemporary IoT-based thermostats typically do not provide a mechanism for direct compressor control, but this can be achieved fairly easily by

remotely setting their set-points to be at least 5 degrees above/below their current temperature readings, forcing them to turn ON or OFF instantly. 5 degrees is sufficient margin to overcome the typical deadband to force instant turn on/off. The process is repeated until the end of the DR event. At the end of the event, the controller restores the scheduled set-point on the IoT-based thermostat which will then follow the regular deadband based set-point following mode.

For load reduction demand response purpose, such as the New York ISO special case resources program [121] or NYSEG's Distribution Load Relief Program (DLRP) [122], it is required to reduce the load by a certain value to qualify for the incentives. The problem can be formulated as finding the optimal demand response to a load reduction DR event that is scheduled from time t_{start} to t_{end} , for a duration of T , so that the aggregated power consumption during the event is kept at the minimum possible value, while respecting the comfort constraints of each individual customers. This can be mathematically expressed as:

$$\oplus \quad \min D_L \quad (1)$$

Subject to:

$$\begin{aligned} \theta_{lower_n} &\leq T_{A_n}^{t_k} \leq \theta_{upper_n} \quad \forall n, \forall k \\ \sum_{n=1}^N P_{HVAC_n} * U_n^{t_k} &\leq D_L \quad \forall k \\ T_{A_n}^{t_{k+1}} &= f(T_{A_n}^{t_k}, T_{M_n}^{t_k}, C^{t_k}, T_o^{t_k}, \Delta t, U_n^{t_k}) \end{aligned}$$

Where,

- D_L : the demand limit (kW)
- t_k : time step. Duration T is divided into a series of time steps $t_{start} \leq t_k < t_{end}$
- $T_{A_n}^{t_k}$: indoor air temperature of house n at time step t_k (°F)
- θ_{lower_n} : lower bound of acceptable temperature - house n (°F)
- θ_{upper_n} : upper bound of acceptable temperature - house n (°F)
- P_{HVAC_n} : rated power of HVAC at house n (kW)
- $U_n^{t_k}$: HVAC state (1=ON/0=off) for house n at time step t_k
- $T_{A_n}^{t_{k+1}}$: air temperature in the next time step - house n (°F)
- f : a function that models second order thermal dynamics of a house and expresses indoor air temperature in the next time step based on the following parameters
- $T_{A_n}^{t_k}$: air temperature in at time step t_k (°F)

- $T_{Mn}^{t_k}$: building mass temperature at time step t_k (°F)
- C^{t_k} : house thermal parameters (e.g., insulation, heat gains and thermal capacity) at time step t_k
- $T_o^{t_k}$: outdoor air temperature at time step t_k (°F)
- Δt : the interval between two time steps

The function f modelling the thermal behavior is based on the second order equivalent thermal parameter (ETP) model [123][124] as shown in Figure 9.

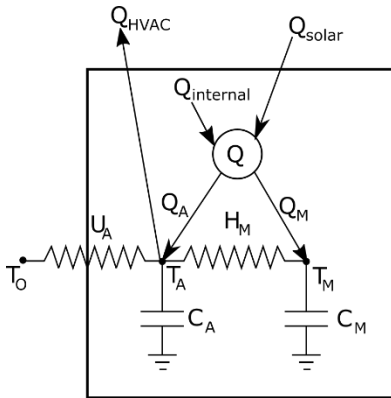

Figure 9: ETP model for a house

Where,

- Q_A : fraction of heat injected into indoor air by internal sources ($Q_{internal}$), and solar radiation (Q_{solar}) (Btu/hr)
- Q_M : the other fraction of heat injected into building mass by $Q_{internal}$ and Q_{solar} (Btu/hr)
- Q_{HVAC} : Heat removed from indoor air by the HVAC (Btu/hr)
- T_A : indoor air temperature (°F)
- T_M : building mass temperature (°F)
- T_o : outdoor air temperature (°F)
- H_M : building mass conductivity to the indoor air (Btu/°F·hr)
- C_M : heat capacity of the building mass (Btu/°F)
- C_A : heat capacity of the air mass (Btu/°F)

U_A : heat conductivity of the building envelop
(Btu/°F·hr)

The house thermal dynamics is driven by the following two equations [125]:

$$Q_A - Q_{HVAC} - U_A(T_A - T_o) - H_M(T_A - T_M) - C_A \left(\frac{dT_A}{dt} \right) = 0 \quad (2)$$

$$Q_M - H_M(T_M - T_A) - C_M \left(\frac{dT_M}{dt} \right) = 0 \quad (3)$$

Solving (2) and (3) for T_A and T_M gives a closed form solution of function f as:

$$\begin{aligned} T_A^{t_{k+1}} &= A_1 e^{r_1 \Delta t} + A_2 e^{r_2 \Delta t} + \frac{d}{c} \\ &= f(T_{A_n}^{t_k}, T_{M_n}^{t_k}, C^{t_k}, T_o^{t_k}, \Delta t, U_n^{t_k}) \end{aligned} \quad (4)$$

$$T_M^{t_{k+1}} = A_1 A_3 e^{r_1 \Delta t} + A_2 A_4 e^{r_2 \Delta t} + g + \frac{d}{c} \quad (5)$$

Variables $A_1, A_2, A_3, A_4, d, c, r_1, r_2$ are constants related to house thermal parameters, the initial value of air, mass and outdoor temperature, heat gains and the HVAC state. All of the houses in this study are assumed to be located in the same geographical area and it is assumed that the outdoor temperature prediction for the next day is available and accurate.

b) Proposed Solution

The solution for (1) consists of binary search algorithm to determine the maximum load reduction possible. The binary search algorithm uses a novel greedy algorithm to optimally control HVACs to determine if it is possible to meet a certain demand limit without exceeding the temperature comfort boundary of all the houses. This is discussed below:

Determination of Optimal D_L

This algorithm searches for the minimum value of D_L using binary search. We know that equation (6) gives the possible range of solution for D_L , because at most, we can limit the total power to be equal to zero by completely turning off all the HVAC, or at max we can surely limit the power within the sum total power of all HVAC units.

$$0 \leq D_L \leq \sum_{n=1}^N P_{HVAC_n} \quad (6)$$

The binary search is started with the first trial equal to the middle of the range in (6).

$$D_{L_1} = \frac{1}{2} \sum_{n=1}^N P_{HVAC_n} \quad (7)$$

Then, for this trail value of D_{L_0} and for any subsequent trail value D_{L_k} we need to determine if it is possible to control the set of HVAC for the control duration such that the aggregate power is always kept below the D_{L_k} and the comfort constrains are also respected; or in other words, we need to check if a solution exist such that the constraints in the equation (1) can be satisfied. In order to check if a solution exist for a given D_{L_k} , we could just try to apply an optimal HVAC control algorithm, that always try to keep the aggregate power below D_{L_k} , and maintains the comfort constraint for as long as possible. If this algorithm cannot maintain the comfort constraint for the control duration while maintaining aggregated power below D_{L_k} , no other algorithm can (since this is an optimal algorithm), and hence it's not possible to satisfy the constraint in equation (1) with that D_{L_k} . We can think of this optimal algorithm as a function $f_O(D_{L_k})$ (discussed in Section III(C)) that returns true if the algorithm can satisfy the constraint with the power limit D_{L_k} and returns false otherwise. Then the next trail value is calculated following the binary search algorithm, increasing the value if the demand limit can be met, and decreasing the value if not, until the changes on the demand limit is below certain threshold (0.1% of the maximum demand limit, $D_{L_{max}}$). The algorithm is shown below:

Algorithm 1 Finding

optimal D_L

1: $right = \sum_{k=1}^n Phvac_n$	10: else:
2: $left = 0$	11: break
3: $D_{L_0} = right$	12: if $f_O(D_{L_k})$:
4: $k = 1$	13: $right = D_{L_k}$
5: $tol = 0.001 * right$	14: else:
6: while True:	15: $left = D_{L_k}$
7: $mid = (right + left) / 2$	16: $k = k + 1$
8: if $abs(D_{L_{k-1}} - mid) > tol$:	17: end while
9: $D_{L_k} = mid$	18: return D_{L_k}

Since the time complexity of a binary search algorithm is $O(\log(N))$, up to 0.1% of the $\sum_{k=1}^n Phvac_n$ can be reached within at most 10 iterations ($\lceil \log_2(1000) \rceil = 10$), which is very efficient.

Optimal HVAC Control for a Given D_L

Now, we describe the function $f_O(D_{L_k})$, which, for a given D_{L_k} , optimally controls the HVAC so that the aggregated power is always kept below D_{L_k} , and maintains the comfort constraints

for as long as possible. If the comfort constraints can be maintained for the whole control duration, it returns true, otherwise it returns false.

For the function $f_O(D_{L_k})$ to determine if the aggregated power can be kept below D_{L_k} , an optimal HVAC control algorithm is described next. This algorithm selects a set of HVACs during each time step, so that the comfort constrained is maintained and the aggregated power remains below the demand limit D_{L_k} .

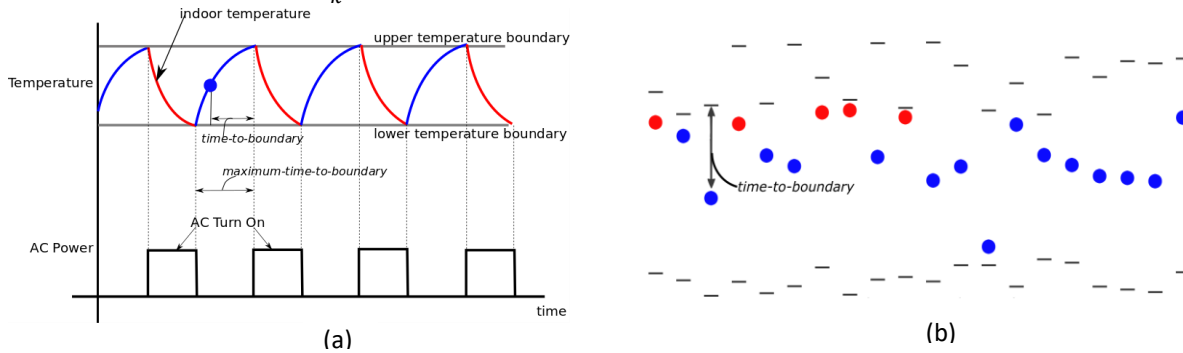

Figure 10: (a) Illustration of the typical operation of AC (b) Alternate view of the problem

To explain the motivation of the algorithm, first, let us look at the typical operation mechanism of HVAC (termed just AC) during cooling mode of operation, illustrated in Figure 10 (a). Based on the setpoint set by the user and the deadband of operation, the thermostat will turn on/off the AC so as to always maintain the temperature to be within the upper and lower temperature boundary. As the temperature rises and reaches the upper temperature boundary, the AC is turned ON, and the temperature starts falling down. When the temperature reaches the lower temperature boundary, the AC is turned off, and the temperature starts rising up again.

In Figure 10 (b), the same mechanism is illustrated for multiple houses using a set of balls between floor and ceilings as an analogy. The vertical position of the (red and blue) balls represent the indoor air temperature for each house, and the black bars on the top and bottom correspond to the upper and lower temperature bounds of respective houses. Different balls have different weights that correspond to different rated powers of corresponding HVACs. Considering the cooling mode of operation, the temperature naturally rises because of the outdoor temperature and heat gains, which is analogous to the balls vertical positions rising. The rise rate is different for different balls as the heat gain and insulation are different for different houses. The rates are assumed to remain constant for the duration of control, though. Now, during each time step, there is a choice of bringing down a subset of balls (so that their total weight doesn't exceed a limit) out of these N balls at their respective cooling-down rate (which can be different for different balls). The problem then is to repeatedly select the proper subset of the balls to bring down at each time step (and let the rests rise up) so that we prevent any of

these balls from hitting the boundary for maximum possible time, and the total weights of the balls chosen to be brought down doesn't exceed the limit.

This problem can be formulated as a job scheduling problem. First, let us define 'time-to-boundary' for the temperature of house n at a given time t_k as the time it takes for the temperature to hit the upper boundary if the AC is kept turned off. This is the time it takes for a ball to hit its upper wall in Figure 10 (b). The *time-to-boundary*, $B_n^{t_k}$, can be calculated using (4) by solving for Δt that would make the temperature hit the upper boundary, as shown in (8):

$$\theta_{upper_n} = f(T_{A_n}^{t_k}, T_{M_n}^{t_k}, C^{t_k}, T_o^{t_k}, B_n^{t_k}, 0) \quad \forall n \quad (8)$$

Where,

- $B_n^{t_k}$: time to boundary for HVAC of house n at time t_k
- 0 : number zero (because the HVAC state is turned off)

Also, the maximum allowable time-to-boundary, B_n^{max} , for each ball, which is basically the time it takes for the temperature to rise from the lower boundary to the upper boundary can be determined by solving (8) with the $T_{A_n}^{t_k}$ and $T_{M_n}^{t_k}$ replaced by the lower temperature boundary.

Now, instead of looking at individual HVACs in terms of their temperature, upper boundary and lower boundary, they can be viewed in terms of their *time-to-boundary*. This lets us transform Figure 10(b) into Figure 11 (b).

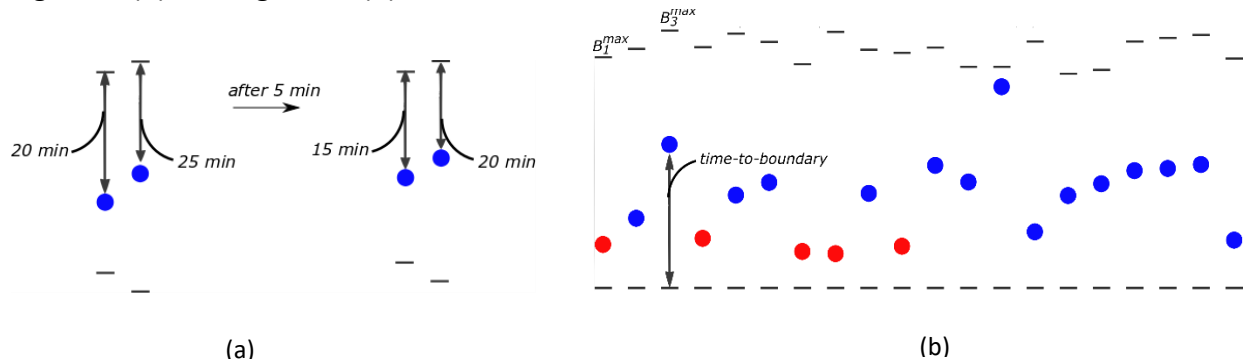

Figure 11: (a) Illustration of the implication of transforming the y-axis from temperature to time-to-boundary. (b) Results after transforming the representation in figure 10(b) to represent the time-to-boundary as the height of each ball

The height of the balls in Figure 11(b) now represent their time-to-boundary, and the lower solid lines represent the lower limit for time-to-boundary, which is 0 for all balls. In this transformed view of problem, all balls fall down at the same rate, except the red balls that are selected to rise up during the current control intervals. The reason why the balls fall at the same rate can be explained by figure 11 (a). Consider two balls at current time which have time to boundary of 20 minutes and 25 minutes. After 5 minutes, if those balls aren't controlled, their

time to boundaries both be reduced by 5 minutes to 15 minutes and 20 minutes. That is their time to boundaries decrease at the same rate, which means the falling rate of all the balls in figure 11 (b) must be the same.

By how much the red balls (which are the balls selected to rise during the control interval) rise depends on the individual house thermal parameters and HVAC cooling capacities. Also, the upper boundary for each ball can be different because the maximum allowable time-to-boundary for each ball is different. Also, the weight of each ball can be different owing to different HVAC rated power.

The proposed algorithm then corresponds to greedily selecting the bottom-most balls in Figure 11(b) during each control interval until their total weight reaches D_L . The balls that would hit the upper boundary if chosen to rise are skipped. The state of the corresponding HVACs remain constant for each control period, and is updated at the beginning of the next control period. This algorithm is analogous to a showman juggling several tennis balls where, at any given time, only two balls are being thrown up and the rest are falling down, but by cleverly switching between the balls, he manages to keep the height of all balls above the ground. As such, this greedy algorithm for HVAC control is named Juggling Algorithm (JA). The algorithm is as follows:

Algorithm 2 Juggling Algorithm (JA) for HVAC control

1: Get D_L	11: if $P_{HVAC_n} +$
2: for each time step k :	$sum \leq D_L$:
3: for each HVAC n :	12: $U_n^{tk} = 1$
4: Calculate B_n^{tk} by	13: $sum =$
solving (7)	$sum + P_{HVAC_n}$
5: end for	14: else:
6: $sorted_hvac \leftarrow$ sort	15: $U_n^{tk} = 0$
based on B_n^{tk}	16: $full = true$
7: $sum = 0$	17: else:
8: $full = false$	18: $U_n^{tk} = 0$
9: for $HVAC_n$ in	19: end for
$sorted_hvac$:	20: end for
10: if $B_n^{tk} + D_n \leq$	
B_n^{max} and not full:	

The D_n in the above algorithm is the time by which the *time-to-boundary* of $HVAC_n$ is delayed (increased) when it is controlled in a control period. It depends on house properties and HVAC capacity. Its numerical value can be determined by calculating the difference between two *time-to-boundary* values obtained using (7): one—chosen at the current temperature, and the other—

made equal to the temperature attained when the HVAC cools the building for one control period. For the proof of optimality of the Algorithm 2 in the Appendix, it is assumed that D_n remains constant for any choice of the starting temperature. This is a valid assumption as D_n has been numerically verified to vary less than 5% when the temperature falls in a narrow region, and is regarded to be insignificant enough to be treated as constant for the proof.

This method of controlling HVACs by holding their state during each control period has also been called deadband free control and is shown effective in eliminating demand drift [126], which is a phenomenon where the aggregated power drifts away from the dispatched power due to natural dispersion of thermostat states [127].

The inspiration for this algorithm comes from classical earliest deadline first algorithm, and the *time-to-boundary*, as we have defined, is equivalent to deadline for the job of controlling the HVAC. More details on this algorithm and its proof of optimality is found in Appendix. It is also easy to show that the smaller the control time steps, the better the chance of satisfying the constraint for the longest time. This is because, if the time steps are large, the temperature in the non-controlled set of houses will have longer time to keep rising and have more chances of hitting the boundary before the start of next time. Having smaller time steps, enables the algorithm to switch between different HVACs more frequently which is conducive to maintaining the temperature of all the HVACs within bounds. However, due to physical limitation of the HVAC compressor, they can't be cycled arbitrarily fast, so there is a lower limit imposed by the compressor health. For this study, the allowed cycling time for the HVAC is assumed to be 5 minutes and is chosen to be the control time step. However, the methods developed here would be applicable to any length of time steps.

Determination of Function f_o

Algorithm 3 shown below serves to complete the function $f_o(D_{Lk})$ that determines if the HVAC control dictated by Algorithm 2 can satisfy the comfort requirement of all customers (i.e., maintaining all house temperature within bounds) while keeping the aggregated HVAC power below D_{Lk} .

Algorithm 3 Algorithm for $f_o(D_{Lk})$

- 1: **for** each time step k:
 - 2: **for** each HVAC n:
 - 3: Calculate $T_{A_n}^{tk}$ using equation(4)
 - 4: **if not** $\theta_{lower_n} \leq T_{A_n}^{tk} \leq \theta_{upper_n}$:
 - 5: **return false**
 - 6: **else:**
 - 7: Assign U_n^{tk} using Algorithm 2
 - 9: **end for**
-

```
10: end for  
11: return true
```

At the beginning of each control period during a DR event, the temperature of each HVAC is calculated using (4). If any of the temperature is found to violate the comfort constraint, then it is deemed unfeasible to meet the requirement of keeping the power below $D_{L,k}$ and the function returns false. If all temperature is found to be within the comfort constraints, then the set of HVAC that needs to be turned on are determined using Algorithm 2. Their states are updated to ON, and the algorithm moves to the next control period. The process repeats, and if, by the end of the DR event, none of the temperature violates the comfort constrain, it is deemed feasible to keep the power below $D_{L,k}$ and the function returns true.

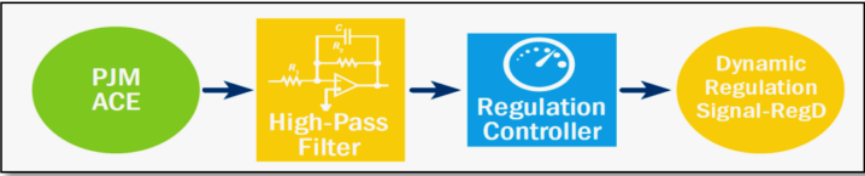

Figure 14: RegD Regulation signal generation block diagram

And a normalized test REGD signal looks like Figure 15.

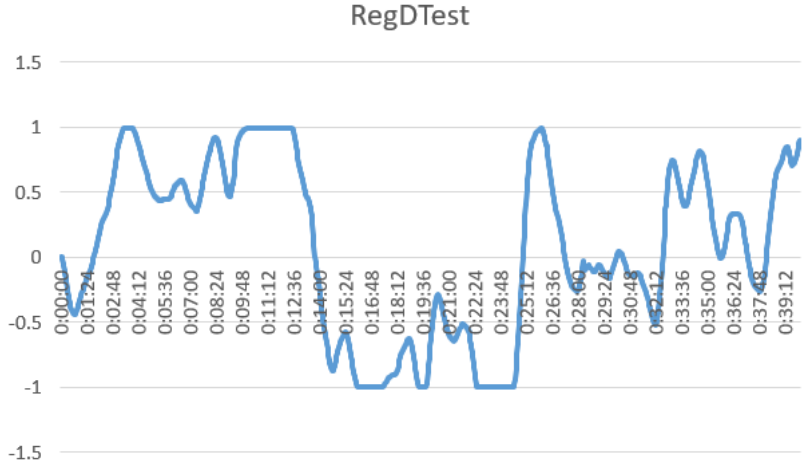

Figure 15: Test RegD signal from PJM

The regulation signal varies every 2 seconds, however a single HVACs cannot be turned on and off every 2 seconds, as it will severely reduce its operating life. So, a minimum on/off time requirement for HVACs needs to be fulfilled. Hence, there is a challenge of controlling the aggregated power to vary 2 seconds so as to follow the regulation signal, while at the same time avoiding controlling the same HVACs too frequently. An efficient algorithm to achieve this needs to be developed.

a) Framework and problem formulation

In this study, a DR framework similar to that proposed in section 3.1.1 is used, where a DR aggregator is in charge of controlling a collection of houses and provide regulation services to the grid. The objective here is to come up with a set of methods and algorithms for the aggregator to control the collection of HVACs so as to gain maximum credit.

i) Calculation of Performance Score (PS) and Regulation Service Pay-off

PJM allows for using sub-metered data to verify the delivery of regulation services [20]. Hence, it is sufficient to collect HVAC power consumption data from each participating house and submit

their aggregation as a proof of regulation service delivery. DR resources providing regulation services must provide at least 0.1 MW of regulation capability (RegMW) and should submit their midpoint MW value [20], [129].

Fig. 1 illustrates the basic principle of regulation. Participants need to vary their power to follow regulation signals as closely as possible. The power varies around a midpoint value, called midPower, by a certain range, called the regulation capability (RegMW). PJM ranks and pays regulation resources based on the performance score (PS) and RegMW a resource can provide. The more closely and quickly the aggregated power follows the regulation signal, the higher will the PS be.

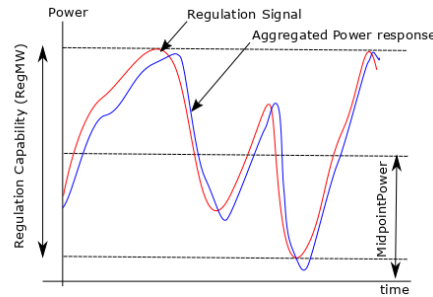

Figure 16: Illustration of regulation service

According to PJM [129], PS is calculated hourly by averaging the correlation score (C_s), the delay score (D_s) and the precision score (P_s) [129], as shown in below.

$$PS = \left(\frac{C_s + D_s + P_s}{3} \right)$$

Each score is explained below:

i) *Correlation score*: This measures the co-relation between the regulation signal at time t ($signal_t$) and the (delayed) load power profile ($response_{t+\delta}$).

$$C_s = \max_{\delta} (cov(signal_t, response_{t+\delta}))$$

Given that the delay (δ) can be between $0 \leq \delta \leq 5min$, hence up to five minutes of delay is allowed to find the maximum covariation between the regulation signal and the load response.

ii) *Delay score*: This is the measure of the delay between the change in the regulation signal and the corresponding change reflected in the load power. This is calculated as:

$$D_s = \left| \frac{\delta_{max} - 5min}{5min} \right|$$

Where, $\delta_{max} = \operatorname{argmax}_{\delta} (cov(signal_t, response_{t+\delta}))$

iii) *Precision score*: This measures how closely the aggregated power matches the regulation signal in magnitude.

$$P_s = 1 - \frac{1}{n} \sum_{i=0}^n \left| \frac{response_i - regulation_i}{regulation_i} \right|$$

Where, n is the number of 10-second intervals in an hour; $response_i$ is the actual MW load during a two-second interval, i ; and $regulation_i$ is the regulation signal for that period, which varies between $-RegMW/2$ and $+RegMW/2$ around the midPower.

PJM requires the PS to be 75% or better on three consecutive tests to qualify for participating in the regulation market. And during participation, the historical running average PS of past 100 participation hours cannot be less than 40%.

The pay-off for regulation services, i.e., Total Regulation Credit (TRC), is determined as the sum of Capacity Credit ($C_{capacity}$) and Performance Credit ($C_{performance}$) [129], where:

$$C_{capacity} = RegMW \times PS \times CCP \quad (9)$$

$$C_{performance} = RegMW \times PS \times MR \times PCP \quad (10)$$

$$TRC = C_{capacity} + C_{performance} \quad (11)$$

The CCP (Capability Clearing Price) and PCP (Performance Clearing Price) are determined by PJM through the wholesale market clearing process and can be considered independent variables for the optimization purpose. MR (Hourly Mileage Ratio) is the ratio of the hourly mileage of the regulation signal to the 30-day average of mileage of RegA and is an independent variable as well.

ii) Maximizing Regulation Service Pay-off

The objective is to maximize the TRC. Assuming that the regulation service is to be provided for a period T (from t_{start} to t_{end}), to maximize the total credit which is proportional to $PS \times RegMW$ (as per (11)), the objective can be stated as:

:

$$\text{maximize } PS \times RegMW \quad (12)$$

Subject to:

$$\begin{aligned} \theta_{lower_n} &\leq T_{A_n}^{t_k} \leq \theta_{upper_n} \quad \forall n, \forall k \\ response_{t_k} &= \sum_{n=1}^N P_{HVAC_n} * U_n^{t_k} \quad \forall k \\ T_{A_n}^{t_{k+1}} &= f(T_{A_n}^{t_k}, T_{M_n}^{t_k}, C^{t_k}, T_o^{t_k}, \Delta t, U_n^{t_k}) \\ U_n^{t_k} &= 1 \text{ if } U_n^{t_{k-1}} = 1 \text{ and } t_k - t_{last_{ON}}^n \leq MIN_ON \\ U_n^{t_k} &= 0 \text{ if } U_n^{t_{k-1}} = 0 \text{ and } t_k - t_{last_{OFF}}^n \leq MIN_OFF \end{aligned}$$

Where,

$RegMW$: The regulation capability provided (kW)

- PS : The performance score, calculated based on response and regulation signal as per [129].
- t_k : Time step. Duration T is divided into a series of time steps $t_{start} \leq t_k < t_{end}$
- $T_{An}^{t_k}$: Indoor air temperature of house n at time t_k ($^{\circ}F$)
- θ_{lower_n} : Lower/upper bounds of acceptable temperature of house n ($^{\circ}F$)
- θ_{upper_n}
- P_{HVACn} : Rated power of HVAC at house n (kW)
- $U_n^{t_k}$: HVAC state (1=ON/0=OFF) for house n at time t_k
- $T_{An}^{t_{k+1}}$: Air temperature in the next time step - house n ($^{\circ}F$)
- f : A function that models second order thermal dynamics of a house and expresses indoor air temperature in the next time step
- $T_{An}^{t_k}$: Air temperature at time step t_k ($^{\circ}F$)
- $T_{Mn}^{t_k}$: Building mass temperature at time step t_k ($^{\circ}F$)
- C^{t_k} : House thermal parameters (e.g., insulation, heat gains and thermal capacity) at time step t_k
- $T_o^{t_k}$: Outdoor air temperature at time step t_k ($^{\circ}F$)
- Δt : The interval between two time steps
- $t_{last_ON}^n$: The latest time step before t_k when HVAC n was turned ON
- $t_{last_OFF}^n$: The latest time step before t_k when HVAC n was turned OFF
- MIN_
ON : The minimum time for which an HVAC must run once it is turned on (i.e., two minutes in this study)
- MIN_
OFF : The minimum time for which an HVAC must remain off once it is turned OFF (i.e., three minutes in this study)

The decision variables are RegMW, midPower and the HVAC state during each control interval $U_n^{t_k}$. The objective in plain words is to find the best RegMW and control strategy for all participating HVACs so that the TRC is maximized, while meeting the comfort requirements and device constraints of all houses. The second order equivalent thermal parameter (ETP) model [21,22] is used to determine function f , same as that was done in section 3.1.1.

iii) Proof for Non-existence of Optimal Solution

In section 3.1.1, an optimal control strategy for a group of HVACs was derived to keep the aggregated HVAC power below a fixed minimum possible level during a DR period while respecting homeowners' comfort constraints. One might think that a similar optimal strategy might exist that makes the aggregated HVAC power optimally follow a regulation signal while respecting comfort constraints. However, regulation signals change every two seconds, which is

much shorter than the minimum HVAC ON/OFF time constraint (e.g., 2-3 minutes) introduced to prevent short cycling of AC compressors. Therefore, no algorithm can preemptively perform optimal control of a group of HVACs to make the aggregated power follow a regulation signal most closely. The proof-by-counterexample for non-existence of optimal solution is presented next.

Consider a simplified regulation problem with just two HVACs, HVAC A in house A and HVAC B in house B. The rated power of both HVACs is assumed to be one unit and the minimum ON/OFF time is set to be three time steps. The HVACs are considered to be in cooling mode of operation and by the beginning of the regulation period at t_0 , both HVACs are assumed to have fulfilled their minimum ON/OFF time requirements, and are free to change their states. Two different cases of regulation signals are considered, Case I and Case II, as outlined at the bottom of Figure 17.

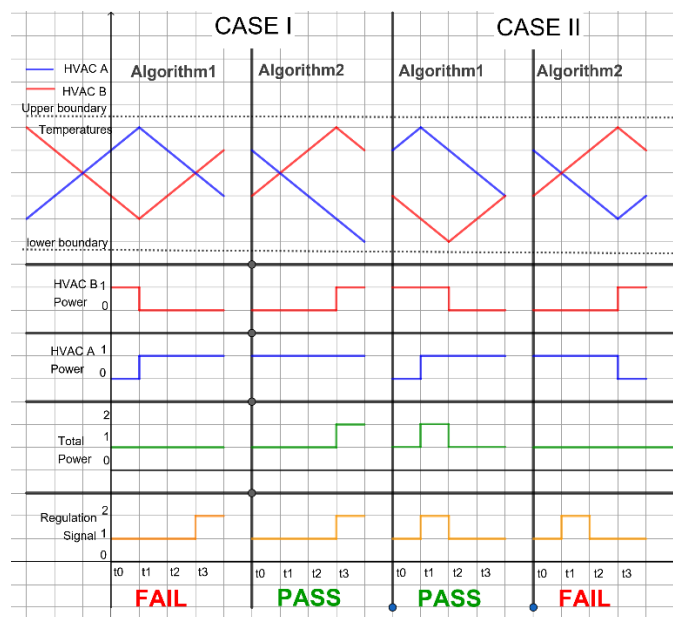

Figure 17: Proof of non-existence of optimal regulation algorithm

First, let us consider Case I.

At t_0 : the regulation signal dictates that the aggregated power be equal to one unit. There can only be two algorithms that can meet this requirement, Algorithm 1 which turns on HVAC B at t_0 and Algorithm 2 which turns on HVAC A at t_0 . No other scenario is possible.

At t_1 : Algorithm 1 turns on HVAC A and turn off HVAC B to prevent house A's indoor temperature from hitting the upper boundary, while Algorithm 2 is forced to keep HVAC A turned on to maintain its minimum ON time requirement.

At t_2 : the states of HVACs need to be maintained same as that at t_1 to fulfill the minimum ON/OFF time requirements. Up till t_2 , the aggregated power matches the regulation signal.

At t_3 : the regulation signal increases the required aggregated HVAC power needs to two units. This requires both HVACs to turn ON. Algorithm 2 can do it by keeping HVAC A on and turning on HVAC B as well, which by now has completed minimum off time requirement. Algorithm 1, however, cannot turn on HVAC B as that would violate the minimum OFF time requirement. Thus, for Case I, Algorithm 2 can follow the regulation signal, and is optimal, whereas Algorithm 1 cannot.

Now, let us consider Case II.

At t_0 : the regulation signal is same as before (at one unit), so both algorithms behave exactly as before.

At t_1 : however, the regulation signal becomes two units, so both HVAC units need to be turned ON to track the signal. Algorithm 1 can turn on HVAC A, and keep also the HVAC B ON to meet the requirement, but Algorithm 2 which just turned OFF HVAC B at t_0 cannot turn it back on just yet, so it cannot meet the regulation signal requirement. Both algorithms can track the signal from t_2 onwards. Thus, for Case II, Algorithm 1 acts optimally, whereas Algorithm 2 does not.

This counter example shows that the same decision made at time t_0 can become either: (i) the only choice to make the aggregated HVAC power follow the regulation signal most closely; or (ii) the choice that *prevents* the aggregated HVAC power from following the regulation signal most closely depending upon how the regulation signals change from t_1 onwards.

Hence, a preemptive optimal regulation algorithm cannot exist. As such, only heuristic algorithms can be designed that can perform decently well in a range of situations. The proposed heuristic algorithms are discussed in the next section.

b) The Proposed Algorithms

Two heuristic algorithms are proposed to deal with aggregated HVAC control following regulation signals, namely: Greedy Algorithm (GA) and Lazy Algorithm (LA). Note that because regulation signals vary every two seconds, our control time step is also chosen to be two seconds. Effectively, the aggregated HVAC power is expected to vary every two seconds following regulation signals, while at the same time, allowing no compressor to cycle faster than the minimum ON/OFF times, which is chosen to be two/three minutes, respectively, in this study.

i) Greedy Algorithm (GA)

At each time step, this algorithm turns on the HVACs with the earliest *time-to-boundary* to track dynamic two-second-interval regulation signals, taking into account customer comfort and additional minimum HVAC ON/OFF time constraint. This algorithm is detailed below. The algorithm is an extension of the juggling algorithm presented in section 3.1.1 with incorporation of minimum HVAC ON/OFF time constraint and modified to track a dynamic two-second-interval regulation signal as shown below:

Algorithm 1 Greedy Algorithm (GA) for HVAC control	
1: Get $RegMW$	15: $U_n^{tk} = 0$
2: for each time step k:	16: $sorted_hvac.remove(HVAC_n)$
3: for each HVAC n:	17: for $HVAC_n$ in $sorted_hvac$:
4: Calculate B_n^{tk} [130]	18: if $B_n^{tk} + D_n^{tk} \leq$
5: end for	B_n^{max} and not full:
6: $sorted_hvac \leftarrow$ sort based on B_n^{tk}	19: if $P_{HVAC_n} + sum \leq D_L^{tk}$:
7: $sum = 0$	20: $U_n^{tk} = 1$
8: $full = false$	21: $sum = sum + P_{HVAC_n}$
9: for $HVAC_n$ in $sorted_hvac$:	22: else:
10: if mustRun($HVAC_n$):	23: $U_n^{tk} = 0$
11: $U_n^{tk} = 1$	24: $full = true$
12: $sorted_hvac.remove(HVAC_n)$	25: else:
13: $sum = sum + P_{HVAC_n}$	26: $U_n^{tk} = 0$
14: if mustNotRun($HVAC_n$):	27: end for
	28: end for

The *time-to-boundary* for the HVAC of house n (B_n^{tk}) at a given time t_k is defined as the time it takes for the temperature to hit the upper limit if the HVAC remains OFF. The D_n^{tk} in the above algorithm is the time by which the *time-to-boundary* of $HVAC_n$ is delayed (increased) when it is turned ON in a control period. It depends on house properties and HVAC capacity. Its numerical value can be determined by calculating the difference between two *time-to-boundary* values obtained using: one—chosen at the current temperature, and the other—made equal to the temperature attained when the HVAC cools the building for one control period, as done in section 3.1.1. The control period is the control time step (2 seconds) if the HVAC is already ON, or is the minimum-turn-on-time (2 minutes) if the current status of HVAC is OFF.

B_n^{max} is the maximum allowable *time-to-boundary* for the HVAC n , which is a proxy for the lower temperature limit.

The regulation MW level to be met (D_L^{tk}) at time step t_k is calculated as:

$$D_L^{tk} = reg^{tk} * RegMW^{hr} / 2 + midPower^{hr} \quad (5)$$

Where,

- reg^{tk} : Current regulation signal value (varys from -1 to +1) at time t_k
- hr : Current hour, $int(t_k/3600)$
- $RegMW^{hr}$: Regulation capability being delivered for the current hour (hr)
- $midPower^{hr}$: Midpoint power level of the current hour

Determination of $RegMW^{hr}$ and $midPower^{hr}$ is discussed in Subsection III.C.

The function $\text{mustRun}(\text{HVAC}_n)/\text{mustNotRun}(\text{HVAC}_n)$ determines if HVAC_n must run/not-run in the current time step. It returns true if any of the following conditions are met: (i) it was recently turned ON/OFF less than its minimum ON/OFF time ago; (ii) if it is turned ON/OFF right now but turning it OFF/ON for at-least minimum OFF/ON time would result in the indoor temperature hitting the upper/lower boundary; and (iii) if it is turned OFF/ON, but letting it remain OFF/ON for an additional time step would make the indoor temperature hit the upper/lower boundary.

This algorithm is named ‘greedy’ because it greedily prioritizes HVACs with the earliest *time-to-boundary* for being candidates to turn ON.

ii) Lazy Algorithm (LA)

This algorithm is a modification to the GA in that instead of prioritizing HVACs with their earliest *time-to-boundary*, it prioritizes maintaining the state of HVACs (ON or OFF) so as to minimize the state changes. It tends to avoid the job of changing HVAC states for as long as possible, so it is named lazy algorithm. The detail of this algorithm is outlined below:

<p>Algorithm 2 Lazy Algorithm (LA) for HVAC control</p> <p>Replace line 6 in Algorithm 1 by:</p> <p>6: $\text{sorted_hvac} \leftarrow \text{sort based on } B_n^{t,k}$</p> <p>7: $\text{sorted_hvac} \leftarrow \text{sort again based on ON/OFF (ON first)}$</p>
--

The LA is mostly the same as the GA except that the sorted_hvac is stable-sorted again based on current ON/OFF status of the HVACs. This results in HVACs that are already ON to be prioritized for remaining ON (and consequently the HVACs which are OFF are prioritized for remaining OFF) in the current time step. If the current power requirement is unmet by the currently ON HVACs, only then OFF HVACs are considered for turning ON. Within the ON and OFF groups, the decisions remain prioritized by their *time-to-boundary*.

iii) Strength and Weakness of the GA and LA

As GA tends to turn ON the HVACs with the earliest *time-to-boundary*, GA always favors to keep *time-to-boundaries* of different houses close and as much away from zero as possible. Hence, it results in frequent HVAC state changes. If there is an abrupt change in a regulation signal at any given time, many HVACs are likely to be locked out (because of recent state transitions) and cannot immediately respond to the signal. However, because the *time-to-boundaries* are concentrated and away from zero, HVAC states would likely be maintained for considerably long time compared to LA before the HVACs are forced to turn ON/OFF to prevent *time-to-boundary* from becoming zero (i.e., the temperature hitting the boundary).

On the other hand, LA lets HVACs maintain their states unless the temperature comfort constraints are to be violated. This minimizes unnecessary state transitions, and reserves the opportunity to abruptly change states if required in a short notice as per the regulation signal.

However, it lets the *time-to-boundaries* to disperse and float near zero or *maximum-time-to-boundaries*. Hence, should an abrupt change of large magnitude occur in the regulation signal (this will require ON/OFF responses from most of the participating HVACs), because the *time-to-boundaries* are already near the limits, this algorithm will not be capable of delivering that level of power for an extended period of time.

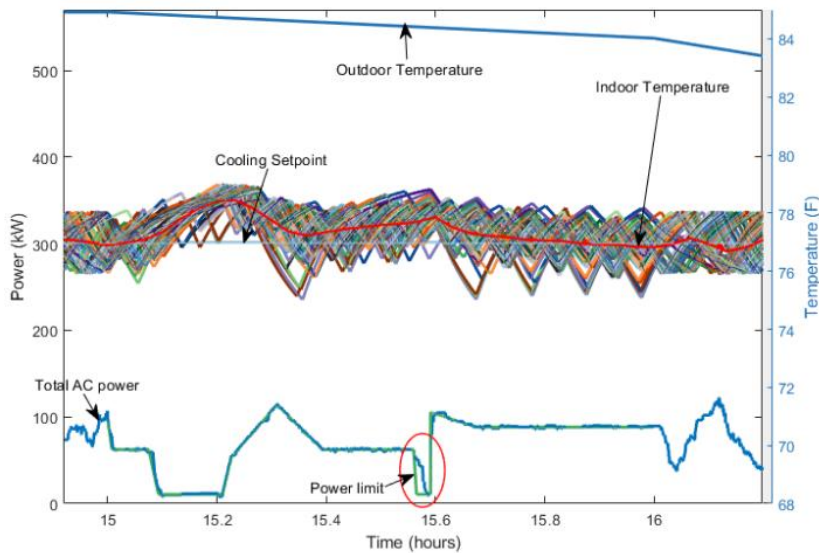

Figure 18 Performance of the Greedy Algorithm(GA) with a test regulation signal

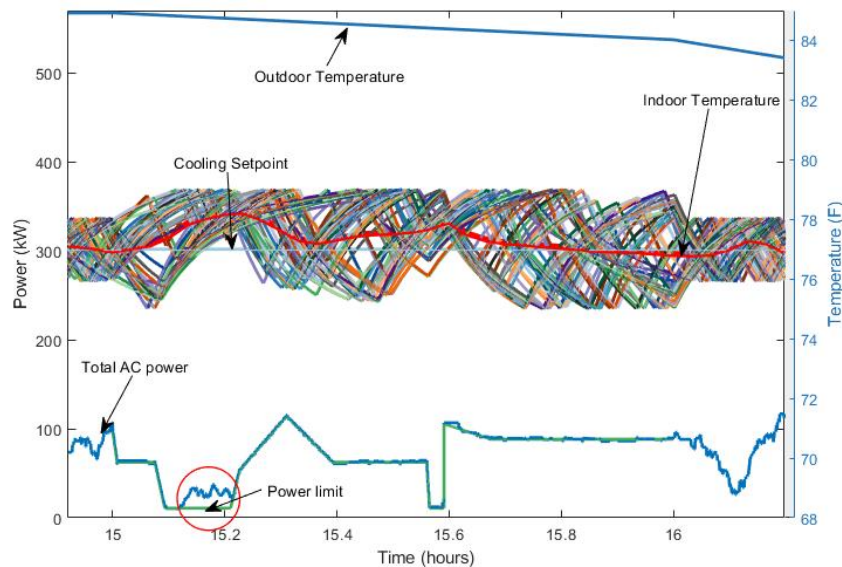

Figure 19 Performance of the Lazy Algorithm(LA) with a test regulation signal

A simulation study (the parameters of simulation will be described in detail in next section) is conducted with 50 houses, for a custom designed regulation signal for one hour (from HE15 to

HE16) designed to bring out the weakness and strength of each algorithm. Figure 18 shows the result with using GA and Figure 19 shows the result with LA. Around hour 15.2, the LA fails to maintain the low power limit required by the regulation signal, because it had lazily allowed many HVACs to remain off and those HVACs now needed to be turned ON to prevent them from hitting the upper boundary. The GA has no such problem at this point and can maintain the power limit. At around time 15.6, when the power limit abruptly shoots down as per the regulation signal, the GA cannot quickly follow it, because it have had recent state transitions of HVACs and they are locked out (so cannot respond), however, LA has no such problem and can swiftly follow the regulation signal. This shows that none of the algorithm is universally better, and each has its weakness and strength, so the overall performance will depend upon the regulation signal. In the simulation study in the next section, we test the performance with various real-world regulation signal and find out which algorithm performs best in real-world cases. In addition, the impacts of temperature comfort range, regulation signal type and signal delay on the PS and TRC are evaluated.

c) Determining $midPower^{hr}$ and RegMW

$midPower^{hr}$ and RegMW are determined as follows:

i) Determining the midpoint level ($midPower^{hr}$)

One of the major constraints is to maintain the indoor temperatures of all participating houses within the upper and lower temperature boundaries. The indoor temperature is a function of the cooling energy expended by an HVAC. If the total hourly energy expenditure during a regulation period remains the same as the energy expenditure without regulation, the average indoor temperature of the house can be expected to be about the same level with or without regulation. Studying PJM's historical RegD signals shows that although the mean value varies hour to hour, on average in a year the mean is centered around zero. This implies, if the midpoint level is chosen to be same as the hourly average HVAC power consumption (without regulation), the same amount of energy is consumed with regulation as without regulation. Hence, the average indoor temperature can be more or less maintained to be around the same value without letting them drift. Thus, the midpoint power level is chosen as: $midPower^{hr} = basePower^{hr}$, where, $basePower^{hr}$ is the average power consumption of all HVACs for hour hr without regulation. Participating in the day-ahead market, the average power consumption of the HVACs can be estimated for the next day by using load forecasting techniques [131].

ii) Determining the RegMW

RegMW should be selected such that the total regulation credit (TRC, which is proportional to $PS * RegMW$ as per (3)) is maximized. Since the midpoint power is fixed at $basePower^{hr}$, the maximum

value of $\text{RegMW} = \text{RegMW}_{\max} = \min(2 * \text{midPower}^{hr}, 2 * (\text{maxPower}_{hr} - \text{midPower}^{hr}))$ where maxPower_{hr} is the total power of all the HVACs combined.

As RegMW is decreased from its maximum value, PS can increase, thereby having the potential for the credit to increase. A binary search algorithm, similar to that used in section 3.1.1[130] to determine best demand limit, could be used that determines the optimal RegMW for each hour by iterating the RegMW value and using a simulation model to determine the performance score and calculating the TRC at each iteration step. However, simulation study carried out by varying the RegMW down from the maximum towards its 50% value for a various assortment of real world regulation signals and for various hours of the day, show that the PS does not increase fast enough or at all to compensate for the reduced RegMW. Hence, the maximum credit is always available at the maximum RegMW. This is illustrated in Figure 20 for various values of RegMW normalized with respect to RegMW_{\max} for a simulation run of 100 houses using LA for demonstration, as GA and LA exhibit similar properties.

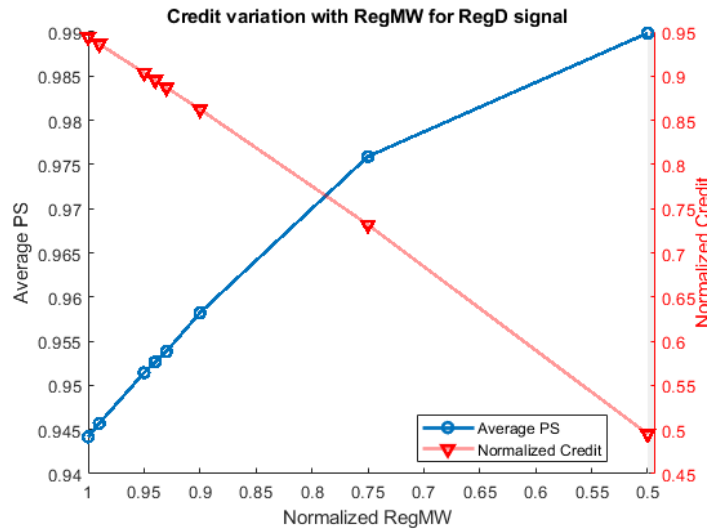

Figure 20 Average PS and regulation credit variations with RegMW for RegD.

3.2 Extensible DR simulation Framework with the Detailed Residential Module

3.2.1 Residential Building Thermal Model and HVAC Model Based on Physical Equations

The first step in designing the DR simulation tool is to have a detailed residential thermal model. The thermal modelling for the house follows that used in GridLAB-D [125], [132].

The houses are modelled using second order equivalent thermal parameter model [123][124], as shown in Figure 21 below:

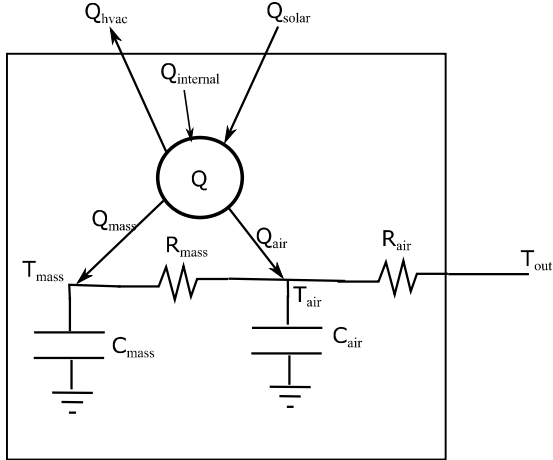

Figure 21: ETP model of a house

Where,

- Q_A : fraction of heat injected into indoor air by internal sources (Q_{internal}), and solar radiation (Q_{solar}) (Btu/hr)
- Q_M : the other fraction of heat injected into building mass by Q_{internal} and Q_{solar} (Btu/hr)
- Q_{HVAC} : Heat removed from indoor air by the HVAC (Btu/hr)
- T_A : indoor air temperature ($^{\circ}\text{F}$)
- T_M : building mass temperature ($^{\circ}\text{F}$)
- T_O : outdoor air temperature ($^{\circ}\text{F}$)
- H_M : building mass conductivity to the indoor air (Btu/ $^{\circ}\text{F}\cdot\text{hr}$)
- C_M : heat capacity of the building mass (Btu/ $^{\circ}\text{F}$)
- C_A : heat capacity of the air mass (Btu/ $^{\circ}\text{F}$)
- U_A : heat conductivity of the building envelop (Btu/ $^{\circ}\text{F}\cdot\text{hr}$)

The thermal dynamics is driven by the following two differential equations, one for the indoor air temperature T_A and the other for the mass temperature T_M :

$$Q_A - Q_{HVAC} - U_A(T_A - T_O) - H_M(T_A - T_M) - C_A \left(\frac{dT_A}{dt} \right) = 0 \quad (9)$$

$$Q_M - H_M(T_M - T_A) - C_M \left(\frac{dT_M}{dt} \right) = 0 \quad (10)$$

Solving (2) and (3) for T_A and T_M gives a closed form solution of function f as:

$$T_A^{t_{k+1}} = A_1 e^{r_1 \Delta t} + A_2 e^{r_2 \Delta t} + \frac{d}{c} = f(T_{A_n}^{t_k}, T_{M_n}^{t_k}, C^{t_k}, T_o^{t_k}, \Delta t, U_n^{t_k}) \quad (11)$$

$$T_M^{t_{k+1}} = A_1 A_3 e^{r_1 \Delta t} + A_2 A_4 e^{r_2 \Delta t} + g + \frac{d}{c} \quad (12)$$

Where,

$$a = \frac{C_M C_A}{H_M}$$

$$b = \frac{C_M (U_A + H_M)}{H_M} + C_A$$

$$c = U_A$$

$$d = Q_M + Q_A + U_A T_o$$

$$r_1 = \frac{-b + \sqrt{b^2 - 4ac}}{2a}$$

$$r_2 = \frac{-b - \sqrt{b^2 - 4ac}}{2a}$$

$$A_1 = \frac{r_2 T_{A_o} - \frac{dT_{A_o}}{dt} - r_2 \frac{d}{c}}{(r_2 - r_1)}$$

$$A_2 = T_{A_o} - \frac{d}{c} - \frac{r_2 T_{A_o} - \frac{dT_{A_o}}{dt} - r_2 \frac{d}{c}}{(r_2 - r_1)}$$

$$g = \frac{Q_M}{H_M}$$

$$A_3 = \frac{r_1 C_A}{H_M} + \frac{U_A + H_M}{H_M}$$

$$A_4 = \frac{r_2 C_A}{H_M} + \frac{U_A + H_M}{H_M}$$

Building thermal model requires that the user input the geometric parameters of the building such as floor area, ceiling height, number of stories, window-to-wall surface area ratio, number of doors etc. All of these parameters are optional, and if not supplied, they will default to either: i) a standard average value or ii) randomly selected from a normal distribution reflecting the real-world variation in the value.

The geometry information enables to calculate the air mass and the thermal mass which in turn is used to calculate the C_M , heat capacity of the building mass, and C_A , heat capacity of the air mass using the specific heat capacity and the building mass conductivity to the indoor air, H_M

Also, the geometry along with the R-value (defaults to a standard or randomized value if not supplied) for the floors and walls is used to calculate U_A , the heat conductivity of the building envelope

The calculation of the HVAC cooling capacity, Q_{HVAC} is a bit more involved. First of all, design cooling capacity is calculated based on the design cooling setpoint and design day outdoor temperature and solar radiation. The design capacity is rounded to nearest 6000 btu/hr unit as it matches with market availability.

The cooling capacity is then adjusted for to account for outdoor temperature changes which reduces its capacity. The capacity of performance of HVAC is also adjusted for according to outdoor temperature.

The adjusted cooling capacity is used as the HVAC cooling capacity, Q_{HVAC} , and it is divided by the adjusted cooling capacity of performance to calculate the HVAC power consumption.

Similar procedure is followed for calculating the Heating capacity and power consumption during heating mode.

The internal gain, $Q_{internal}$, is either fed as a predefined heat load with fixed schedule read from a file, or in the comprehensive model, calculated from various appliances usage schedule and occupancy status. The heat gain from internal gain is divided into internal air and internal mass. Similarly, the solar gain, Q_{solar} , is divided into internal air and mass with user chosen (or default) proportion.

The outdoor temperature, T_O , is read from a weather data file.

Finally, equation (11) and (12) is used to calculate the indoor air temperature, T_A and indoor mass temperature T_M after a certain time-step Δt . How the time step is calculated is discussed in Section 3.2.3 - the simulation framework.

3.2.2 Appliances Models

HVAC is inherently linked with house temperature and thermal model so is explicitly modelled as a discrete component of the house. By default, all the rest of the appliances are grouped together into intrinsic end-use device and follow a single intrinsic endues load-profile supplied by the user. This modelling might be adequate for studying HVAC control-based DR in isolation, however, researchers might also be interested in more comprehensive DR that considers other appliances in addition to HVACs. Customizable appliance modules are developed to fill this need.

a) Water Heater

A water heater consists of a water tank with inlet for cold water at the bottom and outlet for hot water at the top. There is a heating element inside the tank, and the power consumed by the heater is modelled as:

$$P_t = P_{rated} * U_t$$

where,

P_i is the electric power consumption of the water heater at time t ,

P_{rated} is the rated power consumption of the water heater. Can be different for different heaters.

U_t is the heater status. 1 for ON and 0 for OFF

The status of the water heater is controlled using a thermostat, which starts heating (turn it ON) once the temperature falls below certain lower level and turns it off once the preset temperature is reached. This default operation will be over-ridable using a DR controller.

The temperature falling rate is dependent upon many factors such as the inlet water temperature, the ambient temperature around the water heater, the insulation of the heater tank, and the water usage. This is modelled by using a temperature fall rate which can be different for different houses, and is modulated using hourly water-usage fraction obtained from survey [133].

b) Clothes Dryer

A clothes dryer consists of a tumbler and a circulation fan rotated using electric motor, and heating coils with variable power level. The clothes dryer is assumed to consume constant power during its operation. The power demand by the dryer is modelled as:

$$P_t = P_{rated} * U_t$$

where,

P_i is the electric power consumption of the dryer at time t ,

P_{rated} is the rated power consumption of the dryer. Can be different for different dryers.

U_t is the dryer status. 1 for ON and 0 for OFF

Once started, the dryer will run for a predetermined duration at the rated power consumption level and cannot be interrupted during DR. It's start time can be delayed, if required. The starting of the dryer is handled by the appliance driver.

c) Clothes Washer

The model of clothes washer is constructed based on the load profile observed in [134].

The washer is assumed to be under one of the four state: Rinse, Wash, Spin and OFF. There are different power consumption and time-duration associated with each of the wash cycle

The following simplified load profile is used:

1. Rinse: 6 watts 2 minutes
2. Wash: 500 watts 15 minutes
3. Spin: 600 watts 2 minutes
4. Rinse: 6 watts, 2 minutes
5. Wash: 500 watts 9 minutes
6. Spin: 600 watts 2 minutes

Once started, the clothes washer will go through the cycles listed above, consuming different power at different stages and when the process is completed, it stops. The starting of clothes washer is handled by the appliance driver.

d) Dish Washer

The model of dish washer is constructed based on the load profile observed in [134]. The various states with their power consumption and duration are listed below:

1. Pre-wash: 10 minutes; 250 to 300 watts
2. Wash-Heating: 10 minutes; 1180 watts
3. Wash: 30 minutes; 250 to 300 watts
4. Drain: 4 minutes; 36-44 watts
5. Rinse-Heating: 10 minutes; 1180 watts
6. Rinse: 10 minutes; 250-300 watts
7. Drain: 4 minutes; 36-44 watts
8. Wait: 5 minutes; 0 watts
9. Dry: 15 minutes; 600 watts

Similar to clothes washer, once started, the dish washer goes through it's various stages, consuming different amount of power. The starting of the dish washer is handled by the appliance driver as well.

3.2.3 Encompassing the Models into a Comprehensive Residential Building Simulation Framework

a) Introduction to Discrete Event Simulation

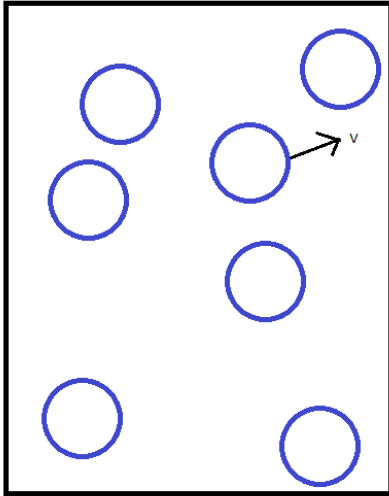

Figure 22: Simulating a bunch of bouncing balls in a box

Consider the problem of simulating a bunch of bouncing balls in a box in a gravity free environment, as depicted in Figure 22 above. Given that each of the balls have a current velocity and are moving in random direction, we need to track the trajectory of a particular ball. A common approach is as follows:

1. Select a small time-step, and find the position of each balls after that time using their current velocity.
2. Check if there is collision between any balls and between balls and walls
3. If there is a collision, update the velocity (to reflect the bouncing).
4. Go to 1

The above approach suffers from two key issues. First, the time-step has to be made very small, so that the balls don't run inside the walls or inside into each other before bouncing back, and thus impacting the accuracy. And, this leads to the second problem: that we need to iterate through a lot of time steps to make progress which slows down the simulation. This simulation paradigm is called continuous simulation. It is powerful in the respect that it can be used for all kinds of situation where the time evolution of the states can be calculated.

Discrete event simulation can help resolve the issues raised in the above paragraph. Here is how discrete event simulation for the above problem would work:

1. Based on the current velocity of each balls, and assuming they move in straight lines, find the earliest future time of collision of each ball with the wall or other ball. This gives rise to a table of N collisions, one each for each of the N balls, and sort them in ascending order, as follows

Ball	Earliest collision time	Collison with
1	2 seconds	2
2	2 seconds	1
3	5 seconds	1
4	8 seconds	3
5	10 seconds	4
6	10 seconds	wall

2. Advance the current time to the earliest event (the top event) in the event queue. Update the position of each balls to the current time. It should be noted that no other collision except for the first collision in the table happens when the time is advanced because the collision times for other balls comes later.
3. Update the velocity of the colliding balls and remove the top entry from the table corresponding to their collision.
4. Calculate the new collision time for the colliding balls and all the other balls in the table which previously collided with the current balls. In the example table above, this means the collision times for balls 3 needs to be updated, as it was going to collide with ball 1 in 5 seconds (but since ball 1's trajectory has now changed at 2 seconds; this needs updating). All other collision time is kept unchanged. Also, new collision times for ball 1 and ball 2 needs to be calculated and updated in the table

After this step, in the first iteration, the above table can look something like this:

Ball	Earliest collision time	Collison with
1	4 seconds	wall
4	6 seconds	3
5	8 seconds	4
6	10 seconds	wall
2	10 seconds	4
3	20 seconds	wall

5. Goto Step 2

It clear that this approach gets rid of the small time-step requirement for accuracy. At first, it might seem that having to calculate the future collisions for all balls in Step 1 is much more time-consuming task. It is time consuming; however, this needs to be done only at the

beginning. During each subsequent iteration, only the state of those balls needs to be updated which got influenced by the previous collision. Because the time can simply jump from event to event, this can considerably speed up the simulation, while at the same time maintain very high accuracy.

It should be noted that discrete event simulation is only possible for systems in which the closest future event time can be pre-calculated. If there are elements of chance/randomness or unpredictable external input in the system, or in some other way not feasible to predict future event time, then discrete event simulation cannot be used. More details on discrete event simulation can be found in [135] and [136].

b) Discrete Event simulation of the proposed residential model

The proposed residential thermal model along with the various appliances model is a good candidate for simulating using discrete event simulation.

i) Discrete event simulation for HVAC

Simulation of the HVAC devices starts with some assumed state for the HVAC (ON or OFF) and calculating their next natural state update time. The state of the HVACs will need to be updated in one of these cases:

Case I: If the current state of HVAC is ON, the state needs updating (to OFF) at the earlier of the following two times:

- i) the time it takes for the indoor temperature to reach the lower boundary. This can be calculated by finding the inverse of the function f in (11) and using $U_n^{tk}=1$ to indicate that HVAC state is ON

$$T_{\text{event}} = \text{lower temperature boundary}$$

$$\text{next_}T = f^{-1}(T_{\text{event}}) \Big|_{T_A, T_M, C, T_O, U_n=1}$$

- ii) The state over-ride event time (from some DR controller)

Case II: If the current state of HVAC is OFF, the state needs updating at the earlier of the following two times:

- i) the time it takes for the indoor temperature to reach the upper boundary. This can be calculated using the inverse of function f in (11) and using $U_n^{tk}=0$ similar to what was done in the Case I
- ii) The state over-ride event time (from probably some DR controller)

The Figure 23 below shows the discrete time events to which the simulation can jump to.

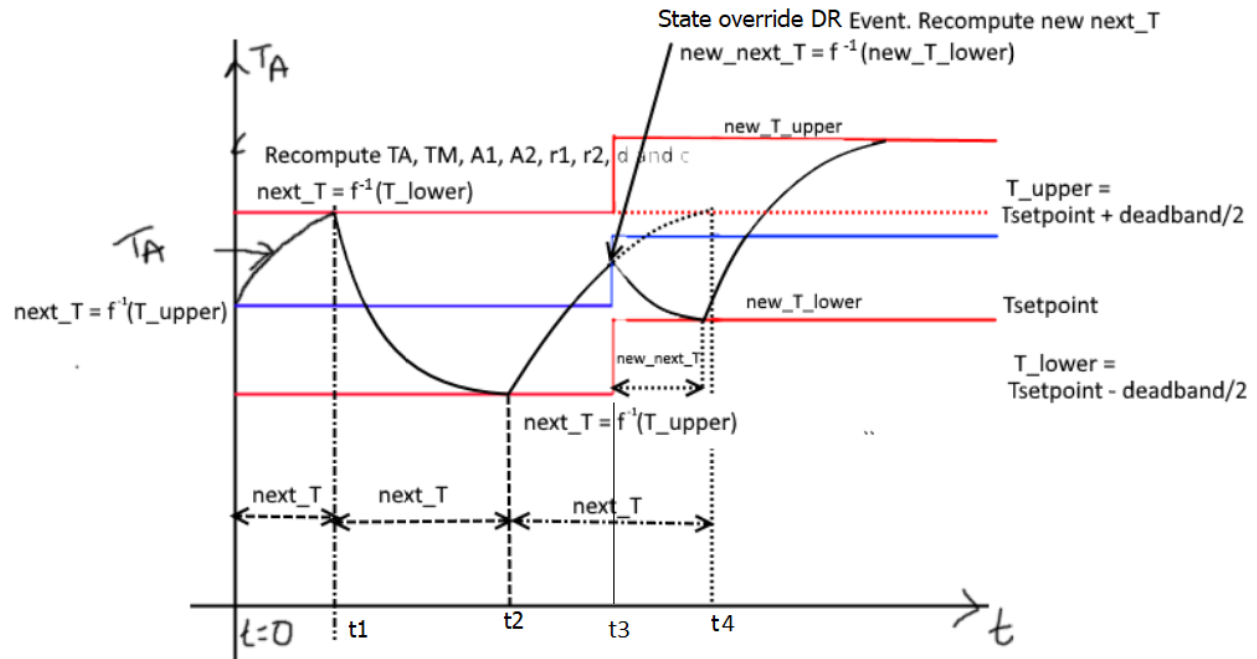

Figure 23: Illustration of discrete event simulation process

At $t=0$, HVAC is turned OFF (room temperature rising) and the next state transition time is calculated as $\text{next_T} = t_1$ by calculating the time required by the indoor temperature to reach the upper boundary. As far as this HVAC is concerned, the simulation can now jump to t_1 at which point the HVAC will turn ON and temperature will start falling down. Similarly, the next state transition time is calculated to be $\text{next_T} = t_2$, which corresponds to the temperature hitting the lower boundary. The simulation can now jump to t_2 and update the HVAC state. At t_2 , there are two tentative state transition time; t_3 when there is a state over-ride event from a DR controller and t_4 when the temperature hits the upper boundary. Since, t_3 comes earlier than t_4 , the simulation should only jump to t_3 at which point the state and the time to next transition both is updated.

ii) Discrete Event simulation for appliances and schedule driver

Schedule driver is the entity that determines when each of the appliance should run. Once the appliance starts running, the appliance model itself determines the power consumption profile for the duration of the run. When a simulation is conducted with an aggregation of multiple houses, if the appliances are to be scheduled realistically, the power consumption profile of the sum of all the appliances should match with the aggregated load shape data obtained from

survey [137]. Figure 24 below shows the load-shape data for an aggregation of clothes washer, for example. As can be seen, there is a variation on the usage pattern based on day of the week or month of the year. Also, the load-shape changes each hour of the day, and have distinct pattern for the weekdays and the weekends.

Figure 77. Clothes Washer Load Shapes

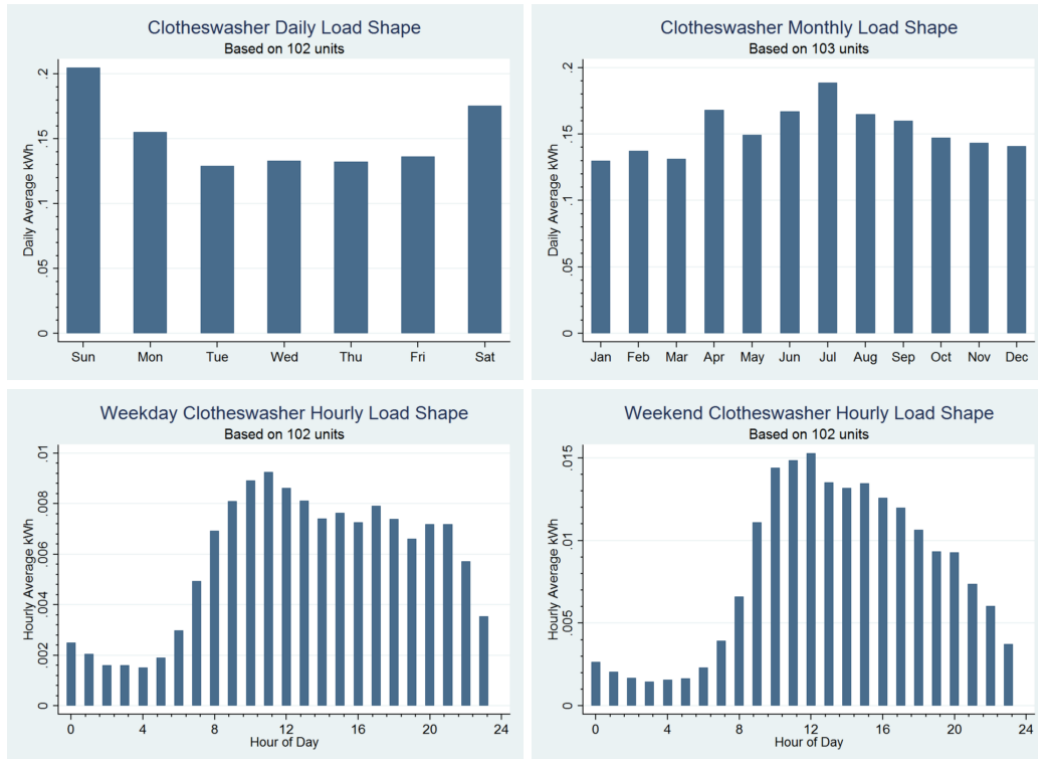

Figure 24: Clothes washer load shape

Gridlab-D, EnergyPlus and other simulation tool achieve the match of the aggregated power consumption and the real-world load-shape data by simply making the power consumption of the implicit appliances be a fraction of the aggregated load-shape. While this does achieve the objective of making the aggregated profile follow the real-world load-shape (since it is just the sum of individual fractional load-shape), at the individual household level, this is a very unrealistic simulation of power consumption of appliances such as dryer, or clothes-washer. Their power consumption does not smoothly vary throughout the day following the load-shape; instead, they run intermittently throughout the week, consuming huge power during operation and no power when not running. It is only the aggregated power of multiple of these appliances among different houses, that follows the load-shape data.

So, the appliance schedule driver should achieve two objectives:

- i) Probabilistically turn on appliances, such that they reflect the real-world use cases, such as the probability of running the washer becomes higher when the amount of accumulated unwashed clothes goes up

- ii) When doing i), the aggregated power consumption profile of the appliances should follow the load-shape data obtained from survey

Both of these objectives can be elegantly solved by using a appliance driver model that turns on appliances exactly the same way the greedy algorithm turns on the HVAC in section 3.1.2. Here, the regulation signal would be the load-shape data, and the time to boundary would be the appliance load (for e.g. amount of accumulated unwashed clothes for the clothes washer). In the case of HVAC, the greedy algorithm prioritizes HVAC with earlier time to boundary; here the greedy algorithm will give the appliance with more load higher chance of running. And, only the that many numbers of appliances would have chance to run in a given time, which would result in the aggregated power being equal to the load-shape data. This is illustrated in the Figure 25 below:

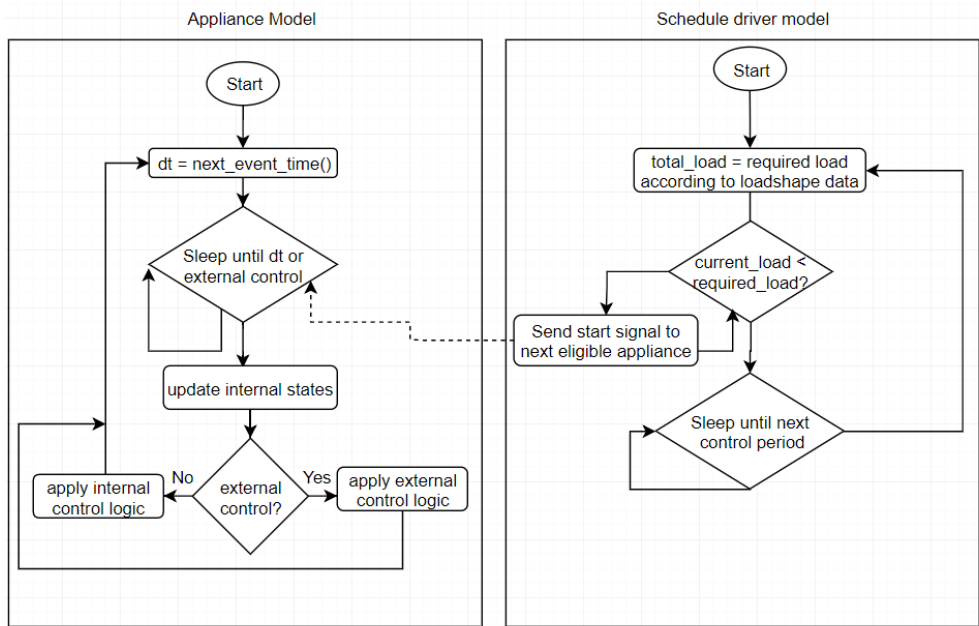

Figure 25: Flowchart of Appliance model and schedule driver model working together

The appliance model begins by calculating the time until next event. For clothes washer, it could be the time until the amount of unwashed clothes reaches above a threshold, or if the washer is already in operation, it could be the time until the next stage of the wash cycle. Then, if no external interruption (control) happens until that time, the appliance will advance to that stage and will update it's internal state (such as advancing the current stage of the wash-cycle, and changing power consumption level according to the stage). It will also apply internal control logic (such as stopping the washer cycle after the end of the last stage). The process is repeated. If there is an external control, such as from a DR controller, or a schedule driver, the state of the appliance is changed according to the external control request.

The schedule driver starts by loading the load shape data for the particular type of appliance and determining the required total load for the particular time to match the load-shape data. It checks if the current_load (which is the total load of all the appliances currently running) is less

than the required load, and if so, dispatches external turn-on control to those appliances, prioritizing based on their current load. The load for dryer, washer and dishwasher would be amount of undried clothes, unwashed clothes or uncleaned dishes, whereas the load for the water heater would be the difference between the preset temperature and the current temperature of the water. This ensures that appliance which are likely to run in the real world (that is those which have high loads) will be likely to run in the simulation as well.

c) Discrete Event simulation in SimPy

SimPy, a python based discrete event simulation library [138], is used as the backbone of the simulation framework. SimPy is used because it allows to develop process-oriented (as opposed to event-oriented) simulation models (and unlike other process-oriented simulation library, doesn't use threads) [136], which helps modularize the different parts of the simulation and is easier to debug and understand.

In SimPy, simulation time advancement and the program control is based on event triggering and yielding. Processes should yield after they are done with state update for the current event, and the program control is not resumed until an event the process is listening to is triggered again. If multiple processes are listening to the same event (for example all DR controller processes in all house will be listening to DR event from the DR service provider), then all those processes get program control one after the other without the system time being advanced. This effectively simulates as if all the processes got chance to operate simultaneously to respond to the event. Only after all the process that are triggered in current time has got chance to run, the simulation time advances to the next earliest event time. So, the simulation alternates between processes updating their internal system states, yielding to one or more events to occur, and repeating the process until the simulation ends.

d) Overall simulation Framework:

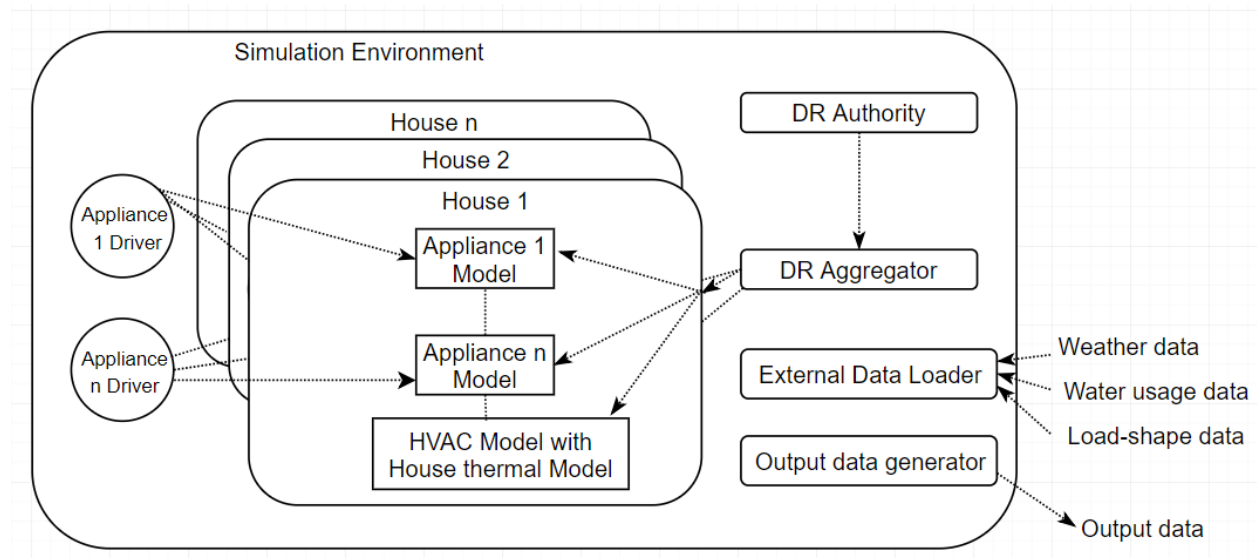

Figure 26: Simulation Framework

In the proposed DR simulation framework, as depicted in Figure 26, each of the distinct entity or agent has been modelled as a SimPy process, which follows object-oriented design paradigm. Hence, there is a House process class, DR Authority and Aggregator process class, Appliance driver process class and various appliance process classes. DR controller. The Appliance process classes are nested inside the house process class for logical consistency.

Each of the appliance process yield to (are listening for) usage driver event, DR aggregator state over-ride event or their own natural state transition event (such as AC being turned on after the indoor temperature rises above the upper threshold). In the absence of DR event, the process jumps from one state transition event to another event, each time updating the house internal variables, and reporting the states (such as power or internal temperature) to the whatever upstream aggregator is attached to the house it resides in. Sometimes, however, the appliance process is triggered by a DR control event, at which case, it's state will be updated as per the control.

The appliance driver process is responsible for triggering the usage of appliances such as clothes washer or the dishwasher such that the aggregated power profile match the load-shape data. This process also aggregates the power consumption of all the appliances for easy output through the output data generator.

The DR authority process, on a predefined time period, can trigger DR event, which it will send to the DR aggregator. The DR aggregator process, upon being triggered by the DR Authority, will dispatch DR start signal to all the registered houses. It can also turn-off or turn-on individual appliances on the registered houses to respond to the DR event, as required.

The external data loader module is accessible to all the processes to load external data, as required during simulation. Finally, the output generator module can be used to save the simulation result.

The class inheritance diagram of the major processes of the simulation framework is shown in Figure 27 below:

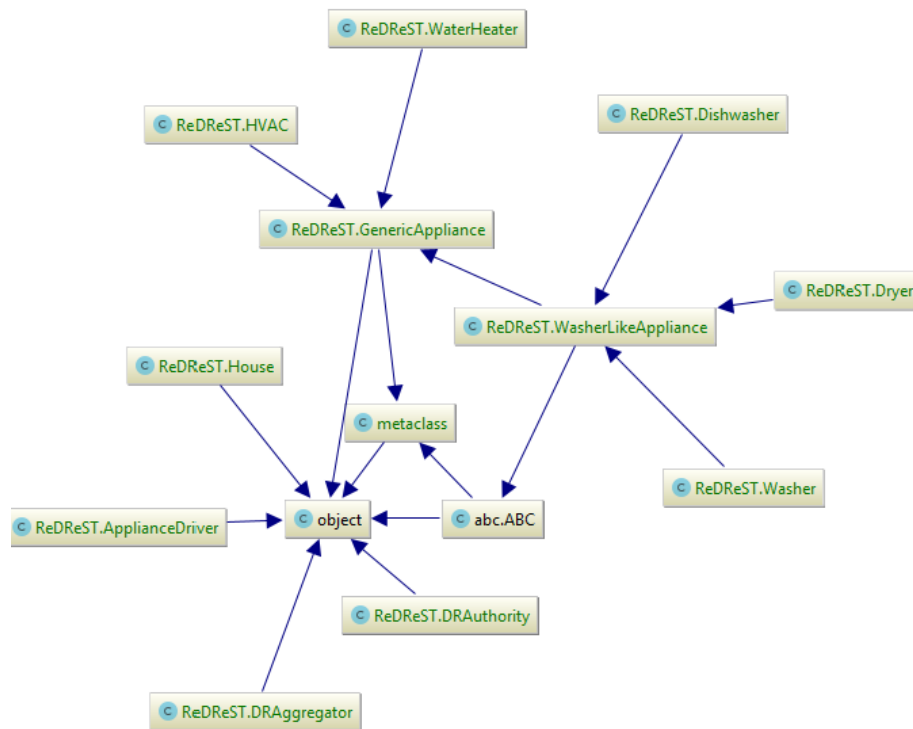

Figure 27: Class inheritance diagram of major processes of the simulation framework

As can be seen, all the appliances inherit from the GenericAppliance class, which provides all the fundamental structure for a generic appliance. This makes it very easy to extend the framework by adding new appliances.

The full source code with documentation for the simulation framework is available at GitHub at: <https://github.com/rajeee/ReDReST>

4.0 Case Study

Some case studies to evaluate the proposed algorithms and the simulation framework is presented in this section. A completed simulation case study consisting of 200 houses for performance evaluation of the optimal load reduction DR algorithm is presented first. It is followed by describing the case study for showcasing the optimal regulation DR algorithm and the proposed method to evaluate its performance. For the simulation framework, a case study composed of a simple base case simulation for validating the house thermal model is presented, and is followed by a case study showing the working of the appliance schedule driver. Finally, an example DR of controlling the clothes washer is shown.

4.1 Optimal Aggregated HVAC Control DR Algorithm Case Study

4.1.1 Case Study for Optimal Load Reduction DR Algorithm

(Parts of this section can match with my previous published work [44])

SimPy, a python based discrete event simulation library [138], has been used to perform the simulation study of the proposed algorithms and framework. SimPy allows process-oriented (as opposed to event-oriented) simulation models and unlike other process-oriented simulation library, does not use threads) [136], which helps modularize the different parts of the simulation and while being easy to debug and understand.

The simulation model consists of the house model, the house controller model and the aggregator model each of which is described below:

House Process:

The house process is based on a simplified version of the house_e model in GridLAB-D [125], [132]. The thermal dynamics has been modelled but the electrical circuits and power flow has been dropped because only the HVAC is being considered. During no-DR event period, the state update of the HVAC doesn't change and equivalently the house process yields until the internal temperature hits the upper or lower level of deadband around the scheduled setpoint. During the DR event, the states are updated only every 5-minute as per the signal from the aggregator as illustrated in Figure 8 which means the process yields to the signal from the aggregator during this time.

House controller process:

The house controller is a nested process inside the house process described above. The controller receives the DR start event signal from the aggregator and sends the house thermal parameters to the aggregator. The controller also calculates the *time-to-boundary* based on its reading of the current temperature from the house model and sends this to the aggregator. Upon receiving the state information from the aggregator, the controller process forces the HVAC in the house process to be ON or OFF accordingly. Basically, it implements the actions illustrated in Figure 8, except that instead of sending signal to the IOT thermostat, it directly modifies the state of HVAC in the house process (which is possible due to nesting). It only yields to the signal from the aggregator.

Aggregator Process:

The aggregator process follows the structure illustrated in Figure 8. The process only yields to time out event which happens every 5-minutes. The DR event time is predefined, and the aggregator waits until that time is reached, after which it starts sending signals to the house controllers to collect information.

The simulation study is conducted on an aggregation of 200 residential houses assumed to be located in Chicago, Illinois. Typical metrological year outdoor temperature and solar insolation data for the same location were used. Thermal parameters for houses were randomized as follows:

- Floor area is randomized using a normal distribution with the mean area of 2,200 square feet and the standard deviation of 400 square feet.
- Aspect ratio of each house is varied uniformly from 1.2 to 1.8.
- R values for windows were varied normally with mean of 1/0.6 and standard deviation of 0.2. R values of doors were varied between 4 to 6.
- Air change is varied from 40% to 80% per hour.
- AC rated capacities were calculated based on floor area [125], [132], and rounded to nearest 6000 BTU/hr.

The simulation study is conducted on a computer with core-i7 3280 3.6Ghz CPU and 16 GB RAM. For the case with 200 houses, the Algorithm 1 took 2.29 seconds to find the optimum D_L , while each step of Algorithm 2, which is used to find the state of HVACs during each control interval in real-time, took only 0.009 seconds per step. In order to confirm the growth order (the time complexity) of these algorithm, simulation is also conducted for 50, 100, 500, 1000, 2000 and 4000 houses and the solution time measured. The result is demonstrated in Figure 28. It can be seen that the solution for real-time scheduling can be obtained in sub-second time even for large number of houses. This demonstrates the feasibility of implementing this algorithm in the real world. The optimal demand limit can also be found out moderately quickly (under a minute), and since the DR requirement is generally communicated several hours in advance by the utility, it makes the algorithm feasible to be used to find the optimal load reduction as well. The measured

linear growth order is consistent with the theoretical growth order that can be inferred from the structure of the algorithms.

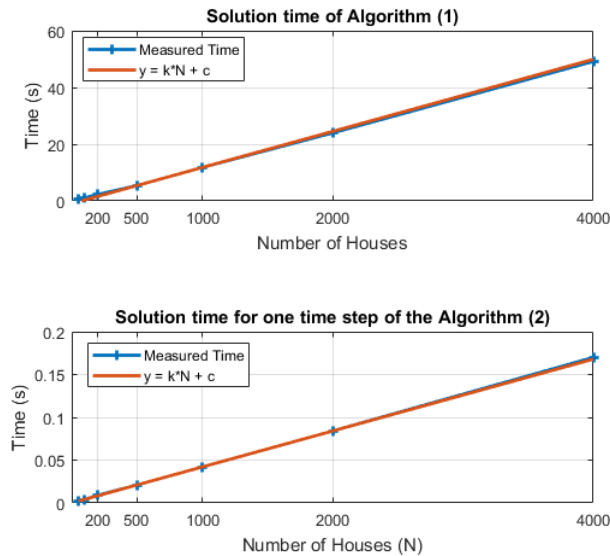

Figure 28: Solution Time growth rate with problem size

The study compares the proposed JA based load control approach with the set-point change based method which is a standard load control method in a transactive control based approach. To make the comparison fair, the upper and lower comfort boundaries during the event were kept the same for both approaches, and were chosen to be 82°F and 72°F respectively. This comfort boundary matches the 22°C to 28°C boundary used in [59] and is based on the ASHARE standard [139]. In order to help the customers, make rational choice about their comfort limits, the aggregator can provide some charts that gives guidelines based on comfort vs savings. To ensure the temperature did not exceed the upper comfort boundary of 82°F during the event, for set-point change based method, the thermostat set-point is set to 81°F with 1°F deadband. During the non-DR period, the set-point is kept at 77°F. The simulation is conducted for a day in August and the DR event is assumed to start from 14:00 to 18:00.

a) Base Case: No Control

First, the case without any DR response is examined. If no action is taken, i.e., HVAC set-points of all houses held constant at 74 F throughout the DR period, the aggregated HVAC power consumption would be as shown in Figure 29. The aggregated HVAC power starts close to zero in early morning and gradually rises in the afternoon owing to increasing outdoor temperature and shaves off towards the evening as the temperature falls. The peak power is 355.4 kW at around 14:47. The individual temperatures of each houses are tracking the 77 F setpoint to within their 1 F deadband, except for the early morning when the temperature is low due to cooler outdoor and no HVACs run during this period as is evident by zero power consumption before 5 a.m.

b) Case I: Juggling Algorithm (JA)

The optimal demand limit from 14:00 to 18:00 was found to be 118.87kW using algorithms proposed in Section III, and the result of controlling the thermostats according to the JA is shown in the Figure 30. During the DR event period, it can be seen that the aggregated power has been kept below the optimal value, maintaining more or less constant level, with the low of 115.14 kW which is just 3.1% less (or 3.73 KW less) than the limit. This is equal to the power of one HVAC unit, so it can be seen that the aggregated power level is kept below the demand limit to within the power level of a single unit.

Indoor temperatures of the houses are same as the base case up until the start of the DR event. After that, the indoor temperature of most of the houses start rising and the temperatures of some of the houses begins to fall at the beginning. This is because the HVACs that are selected to run during the first control period has to operate for the whole 5-minute control interval, since the states of the HVAC are only changed every control interval. This might result in the temperatures of some of these houses selected to run their HVAC during the first few initial period to go below their regular temperature setpoint. This is akin to storing thermal energy (in form of cooled house) at the initial stage of the DR-event which will be useful at the later stage. Near the completion of the DR event, almost all the indoor temperatures approach their upper boundaries (but none exceeds it). This signifies the optimal use of resources.

There is a prominent peak in the aggregated HVAC power after the DR event ends. This is typical occurrence in many demand response programs, and is called demand restrike, where the power consumption momentarily increases to high value after a demand event as the loads synchronously consume power to serve their postponed duty. In this particular problem, the restrike occurs because the set-point based control at 77°F is resumed at the end of DR event and since the indoor temperatures of all the houses are greater than the setpoint, they synchronously turn on. This problem is tackled in Case III discussed in sub-Section D.

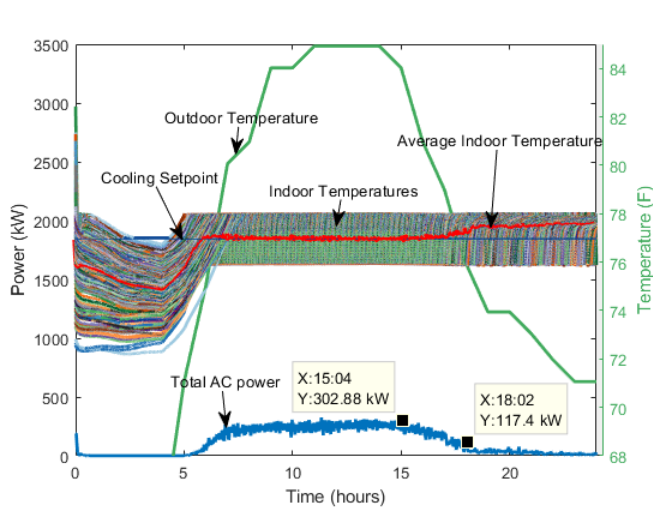

Figure 29: Aggregated HVAC power, outdoor and indoor temperatures in the base case without control (Base Case).

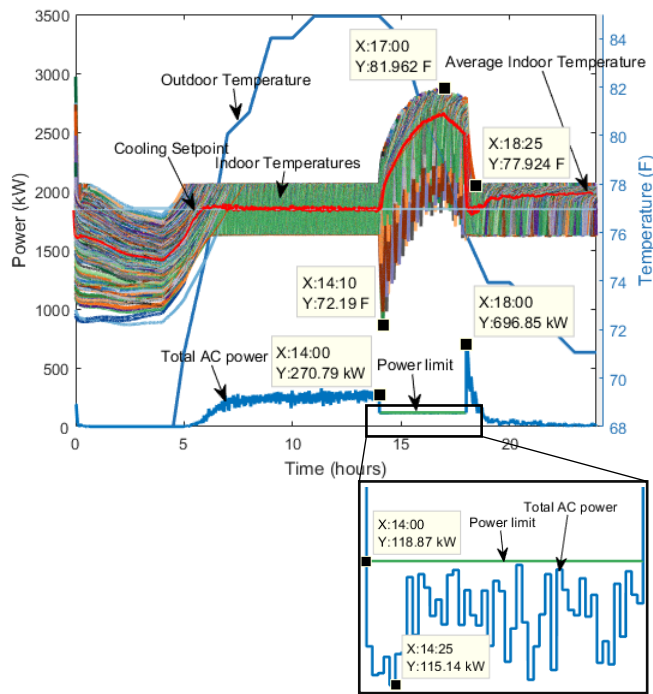

Figure 30: Aggregated HVAC power, outdoor and indoor temperatures with the JA (Case I).

c) Case II: Set-point Change based Control

In this case, the set-points of all thermostats were raised during the DR event to 81°F (deadband is still 1°F, so the upper limit is maintained same as before, 82 °F) to achieve the desired power reduction. The result is shown in Figure 31.

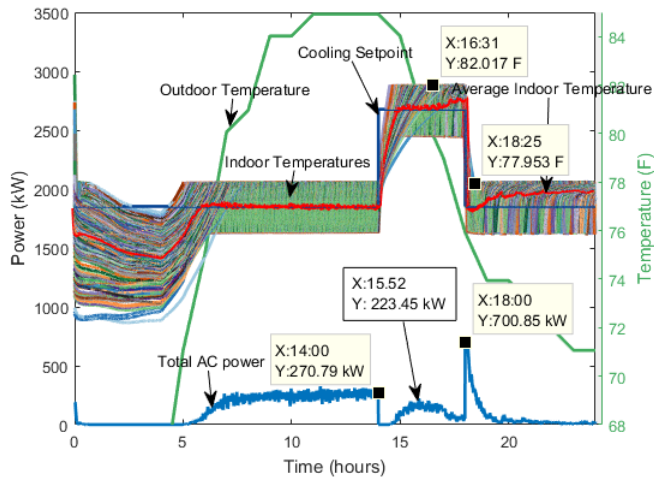

Figure 31: Aggregated HVAC power, outdoor and indoor temperatures with the set-point change based control (Case II).

There is an immediate power reduction (to 0 kW) at the start of the DR event, but the aggregated power creeps up during the middle of the DR event and reaches the peak of 223.45 kW, which is much higher than the case of the JA at 118.87 kW. The energy consumption (detailed in Table 2) at 2.7 MWh is slightly lower than 2.74 in the case of JA though. This reduced energy consumption, however, comes at the price of higher average indoor temperatures. The reason JA is able to maintain a lower demand limit is because, in this case, during the initial stage of the DR event, the aggregated power goes down to zero, but during the later stage, much higher power is required to keep the temperature within boundary. In the JA case, however, the power consumption of 118.87 kW is uniformly maintained, which results in pre-cooling some of the houses at the beginning stage of the DR and that becomes valuable at the later stage so that the temperature can be kept below the upper limit by expending less power. This pre-cooling phenomenon is an inherent feature of JA.

d) Case III: JA with Demand Restrike Mitigation Methods

Two approaches are explored for limiting the demand restrike seen in Case I. They are explained below:

Using demand restrrike limit

A demand limit can be extended for some time even after the DR event. This DR limit, which can be set to be the same power level as the aggregated power before the start of DR event, can be enforced for a duration of D_T such that the demand restrrike is prevented. D_T can be conservatively made equal to at least half of the event duration or its value can be optimally determined by using binary search similar to that used in Algorithm 1. As a case study, the result of limiting the aggregated power to the pre-DR event value of 270.79 kW for up to 35 minutes after the event is shown in Figure 32.

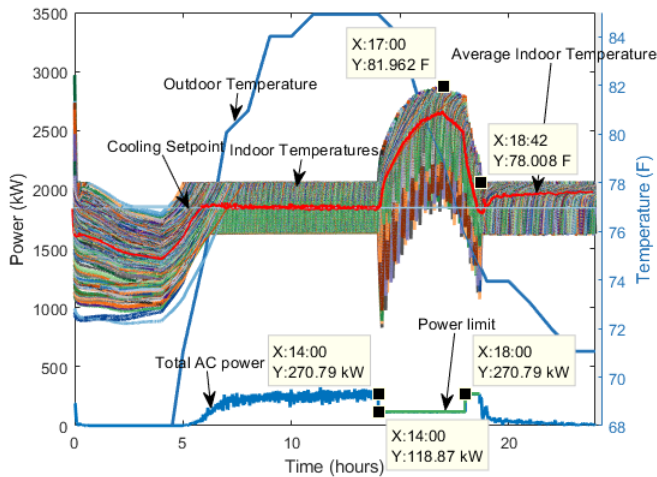

Figure 32: Aggregated HVAC power, outdoor and indoor temperatures with JA and a restrrike limit (Case III.1).

As can be seen, the restrrike has been successfully suppressed below the pre DR-event level. It should be noted that this is realized in expense of delaying the recovery of temperatures in the houses. While the temperatures of all houses returned to within 1 F deadband of 77 F after the event in 25 minutes in case I, it now takes 42 minutes. This delay, however, comes with a slight bonus in the form of reduced energy consumption of 2.72 MWh compared to 2.73 MWh for case I.

Using conservative demand limit (CDL)

One might think that the demand restrrike is the result of the harsh restriction of aggregated power below the absolute minimum demand limit during the DR event, and it is tempting to use a more liberal demand limit in hope of reducing the restrrike. As a case study, the DR limit is made equal to the 1.25 times the value used in Case I, and the result is shown in Figure 33.

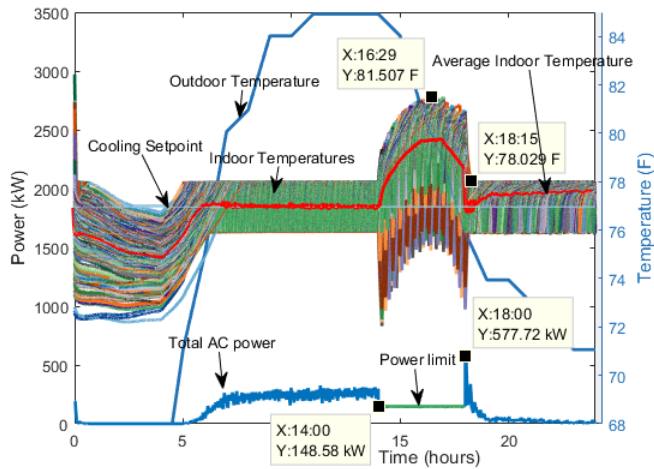

Figure 33: Aggregated HVAC power, outdoor and indoor temperatures with JA with conservative demand limit (Case III.2).

The figure shows that the peak of the aggregated power consumption during restrike decreases from 696.85 kW to 577.72 kW. While, the restrike peak is reduced, it is still significantly higher than the before DR event peak power. It can be noted that the indoor temperatures never reach near the upper boundary of 82°F (signifying non-optimal utilization). This shows that increasing the DR-limit does not help eliminate the demand restrike and supports the previous finding that the restrike occurs because of loss of state diversity [127].

e) Case IV: Effect of randomized constraints

In all of the case studies so far, the desired set-points of all houses were assumed at 77°F and the upper temperature boundary was assumed to be 5°F above that at 82°F. In real world scenario, different houses can have different setpoint, so to test the impact of randomizing the setpoints on the efficacy of the proposed algorithm, a simulation is conducted, where the setpoints have been randomly assigned from 75 to 79. The result is shown in Figure 34. Interestingly, the result remains almost the same as Case III.1 demonstrating that the algorithms are robust enough to handle different setpoints.

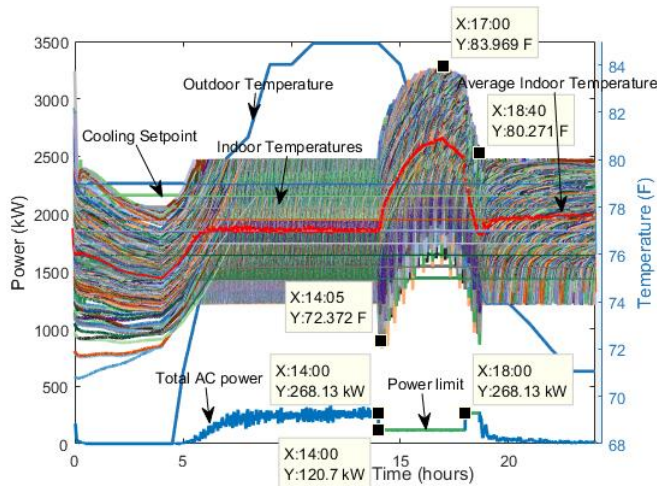

Figure 34: Aggregated HVAC power, outdoor and indoor temperatures with JA, demonstrating randomized constraints (Case IV).

The aggregated power and the average indoor temperature follow almost the same profiles as Case III.1. Even the individual temperatures, although much different than those in Case III.1 at first glance, follow similar profiles in terms of their own set-points and boundaries. This demonstrates that the study so far is directly applicable for the real-world case where houses have different preferred set-points and comfort preferences.

f) Summary and Other Observations

Results of all case studies are summarized in **Error! Reference source not found.2**.

Table 2 Summary of load reduction simulation Results

Control Method	Peak power during DR (kW)	Peak power after DR (kW)	Time to normal temp	Comfort violation degree (°F-h)	Energy Consumption (MWh)	Average AC cycles per day
No Control	302.88	117.4	-	2.10	2.85	66.63
Case I	118.87	696.85	00:25	12.78	2.73	58.75
Case II	223.45	700.85	00:25	16.21	2.70	61.64
Case III.1	118.87	270.79	00:42	13.33	2.72	59.17
Case III.2	148.58	577.72	00:15	9.57	2.76	59.77
Case IV	120.7	268.13	00:40	13.24	2.74	59.80

From the table: the peak power during DR event is reduced in all cases – but the proposed JA yields the optimal control, i.e., limiting the peak power to around 118 kW (Cases I, III.1 and IV).

Mitigating the demand restrike problem by extending the demand limit even after the DR event (Case III.1) reduces the restrike by more than half (i.e., from 696kW to around 270kW).

After the DR event, it takes some time for the temperatures to get back to their regular values for all cases. The discomfort associated with the demand response can be quantified using comfort violation index, which measures the degree-hour time integral of the absolute difference between the desired temperature (which is 77°F) and the actual temperature [79]. The fifth column gives the average comfort violation index for the time interval from 14:00 to 19:00 as that is the time interval influenced by the DR. As can be seen, the setpoint change based control in Case II has the worst performance. The distribution of the comfort violation among different houses is shown in the Figure 35:

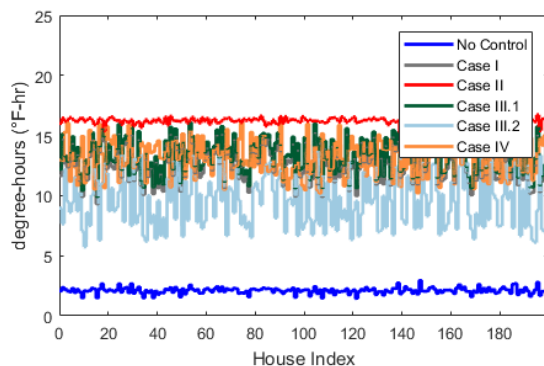

Figure 35: Distribution of comfort violation index among the houses

Figure shows that JA with restrike mitigation (Case III.1) keeps the comfort violation below the setpoint control (Case II) based method for all the cases. But unlike the setpoint control based method, there is quite a variation among houses. This is because, unlike in [79] where even distribution of comfort violation was one of the objective, the objective here is to maximize the load reduction while only *meeting* the comfort requirement. As such, the algorithm might exploit some houses more than the others to maximize the load reduction. In order to make this fair to the customers, the aggregator can make the rewards proportional to the comfort violation endured by the house.

The energy consumption difference between various cases is quite intuitive to explain. All cases perform better than the base case because the comfort requirement is relaxed during DR event which allows HVAC to run less frequently during the event, saving energy. Case II with setpoint change based control, although has a slightly smaller energy consumption than case I, it comes with expense of higher average indoor temperature during DR-event. Case III.1 has even smaller energy consumption which can be attributed to delayed temperature and the price is paid in

terms of higher indoor temperature for longer period. Case III.2 is worse than case III.1 in all aspect except for faster temperature recovery. Finally, the energy consumption of case IV matches pretty closely with case III on which it is based, as expected.

To make sure the algorithms don't severely increase the number of AC cycling, which would decrease the life of AC compressor, the number of AC cycling was tracked and listed in the table. It is observed that the average number of AC cycles actually decreases in all cases compared to the base case. It reduces to an average of 59.17 cycles with Case III.1 compared to average of 66.63 cycles in the base case. This decrease is because during DR event a large fraction of the HVACs remains off and only a small fraction is selected to run during each control interval. This shows that the proposed approach will not result in reduced operating life of the AC due to increased AC cycling.

Although the problem was formulated to make the aggregated power below the maximum limit, DL, it has been observed that the aggregated power is always maintained very close to this limit. As such the work can be extended for applications where the aggregated power needs to track a reference value.

g) Conclusion

The novel algorithm for an advanced load control for HVAC presented for load reduction DR performed much better than existing setpoint change based method in reducing the peak power during DR event. It successfully reduced the peak power by up to 60% which is much better than the set-point change based control that reduced the power by only 26% under the same temperature limits. The proposed algorithm was also successful in efficiently limiting the DR restrike, a feature not typically available in other approaches. Since the proposed algorithm can be readily deployed using IoT based smart thermostats, aggregators can make use of it without additional infrastructures. This can be a great business opportunity for aggregators to sell demand response capability as a service to the grid.

4.1.2 Case Study for Optimal Regulation DR Algorithm

Simulation studies for a collection of 100 houses were conducted using SimPy [138] – a python based discrete event simulation library, using the ETP model [21, 22] as the thermal models of residential houses, similar to the house_e model in GridLAB-D [24, 25]. House floor areas and other thermal parameters were randomized around typical values (e.g., floor area avg of 2200 sq ft) similar to that in [130]. Typical metrological year outdoor temperature and solar insolation data for Sterling, VA, were used. The simulation duration has been set to 20 days starting on August 2nd, and the regulation signals for the same period have been downloaded from PJM. Simulations without regulation services have been conducted with comfort range of $\pm 1^\circ\text{F}$ (a typical thermostat deadband) to determine the basePower for various base set points.

Because the minimum RegMW quantity that would qualify for participating in the wholesale market is 100kW, participation in the regulation services only occurs when $RegMW^{hr}$ is at least 100kW. In the following case studies, LA with the comfort range of $\pm 2^\circ\text{F}$, the base set point of 77°F, RegD signal and no communication delay has been used, unless otherwise noted.

a) GA vs. LA

The variation of PS for all hours during the simulation when regulation was provided is plotted in the Figure 36 for both GA and LA. As shown, for almost all of the cases, LA outperforms the GA by a good margin. The average PS for GA was 89.37% while it was 94.42% for LA.

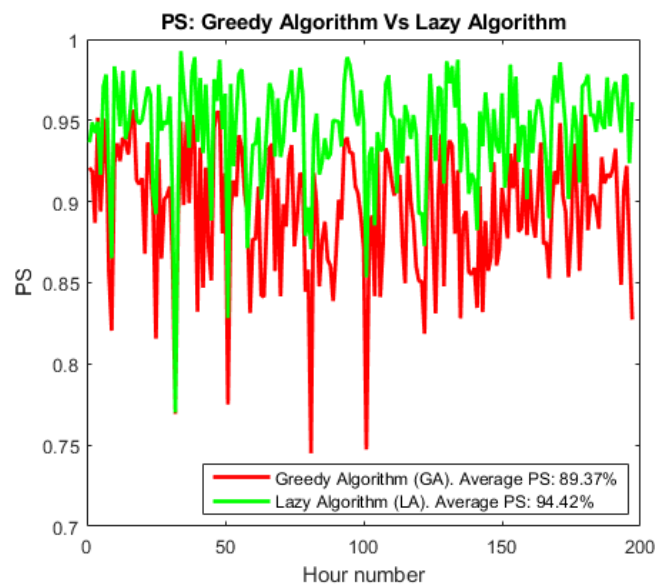

Figure 36 PS for various regulation cases with GA and LA algorithms

A typical example day difference in performance between GA and LA is shown in Figure. 37(a) and Fig. 37(b), respectively. Figure 37(a) shows LA making the aggregated power follow the regulation signal during hours 9 to 10 with PS of 94.78%. During the same condition, the GA in Fig. 37(b) performs slightly poorly, and has PS of only 90.36%. Although there are a few hours

during which GA performs slightly better than LA, LA is found to perform much better than GA for almost all the cases. Hence, LA is used for the remaining analysis in determining the impacts of set points, thermal comfort constraint, communication delay and regulation signal type on regulation services.

b) Effects of using Different Base Set Points

The base set point, i.e., the midpoint value of the temperature comfort range of the houses, is chosen to be 77°F in this study. A simulation sweep was conducted with the base set point chosen to be 75, 76, 77, 78, and 79°F to study its effect on PS, $RegMW_{max}^{hr}$ and consequently the regulation credit (TRC). The plot in Fig. 38(a) shows that as the base set point is lowered from 77°F, the average $RegMW_{max}^{hr}$ increases. This is understandable because it requires more energy to maintain a lower average temperature, and hence the $basePower^{hr}$ needs to increase, which allows for higher $RegMW_{max}^{hr}$. The average PS remains more or less the same, so the regulation credit increases with lower set points, though not by much.

c) Effects of Varying the Comfort Range

A sweep of comfort range from 1°F to 5°F was conducted to study its impact on PS (and consequently directly on TRC). The result in Fig. 38(b) shows that there is a sharp increase in PS when going from comfort range of 1°F to 2°F, but it quickly saturates. Hence, $\pm 2^\circ\text{F}$ seems to be a reasonable tradeoff between comfort and performance.

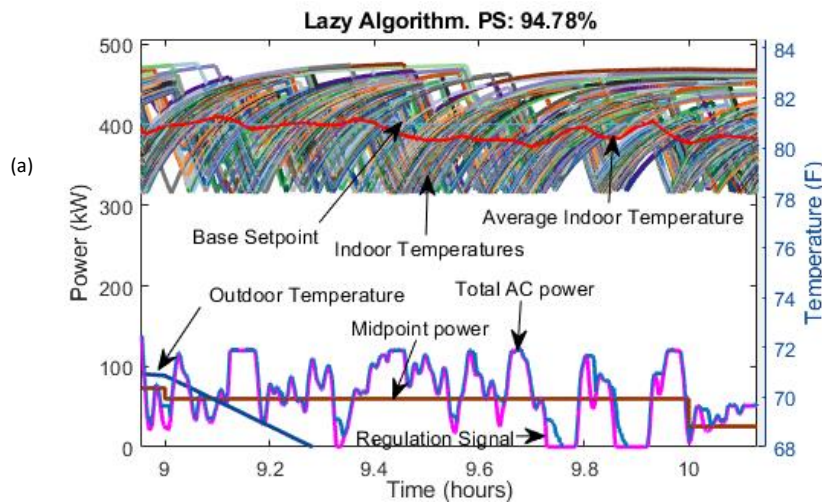

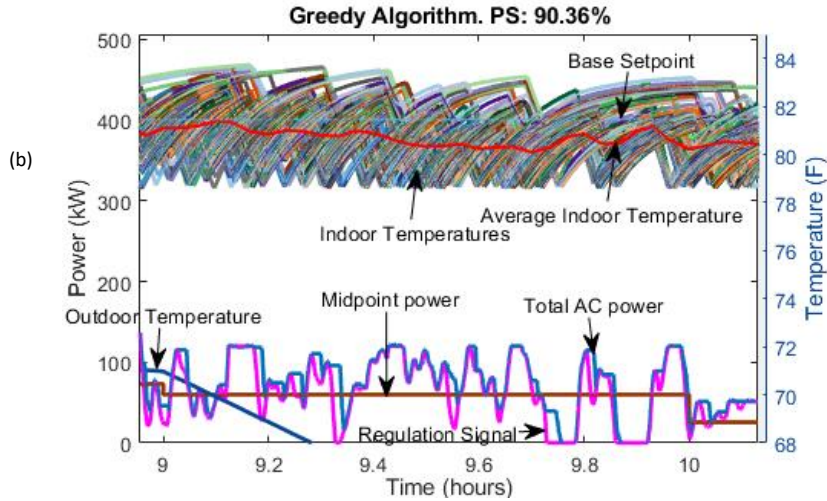

Figure 37 A typical example day difference in PS: (a) LA performing better than GA; and (b) GA performing poorly than LA

d) Effects of Communication Time Delay

So far, we have been assuming that the DR aggregator can change the ON/OFF status of AC compressors with negligible time delay. However, time delays always exist when communicating with smart thermostats, i.e., sending control commands to adjust HVAC set points in real-world implementation. The impact on PS when various communication delays are introduced is studied and Fig. 38 (c) shows the resulting PS when varying the delay from 0 to 20 seconds. As expected, the PS keeps degrading as the delay is increased, but it still remains quite high even up to five (5) seconds of communication delay. As such, the LA algorithm can perform quite well even in real-world scenarios with delays.

e) Performance Analysis with RegA Signals

So far, RegD has been used because, unlike RegA, it is expected to be zero centered. As such, for RegA it is expected that temperatures of participating houses to be saturated at near their upper/lower comfort boundaries more often, and the PS to be not as good as with RegD. Fig. 38 (d) shows the PS while using RegA signal with various value of RegMW, normalized with respect to $RegMW_{max}$. The PS does improve, in general, when RegMW is reduced considerably. However, the PS does not improve fast enough to compensate for the reduced RegMW to improve the regulation credit. As such, just as in the case of RegD, the maximum credit is still obtained at $RegMW_{max}$. But this credit is about 0.7434 units compared to the 0.944 units in the case of RegD (Fig. 3), which is 21.2% less. As such, aggregated HVAC control is much more suitable for RegD signal than RegA. The peculiar decrease and increase of PS around the normalized RegMW of 0.95 and higher (see Fig. 38(d)) is because of the peculiarity of the regulation signal. Serving a higher RegMW in general is harder because it requires turning ON/OFF a large number HVACs which might not always be possible because of the temperature constraints. However, sometimes, the opportunity to turn ON greater number of HVACs can become useful to keep the

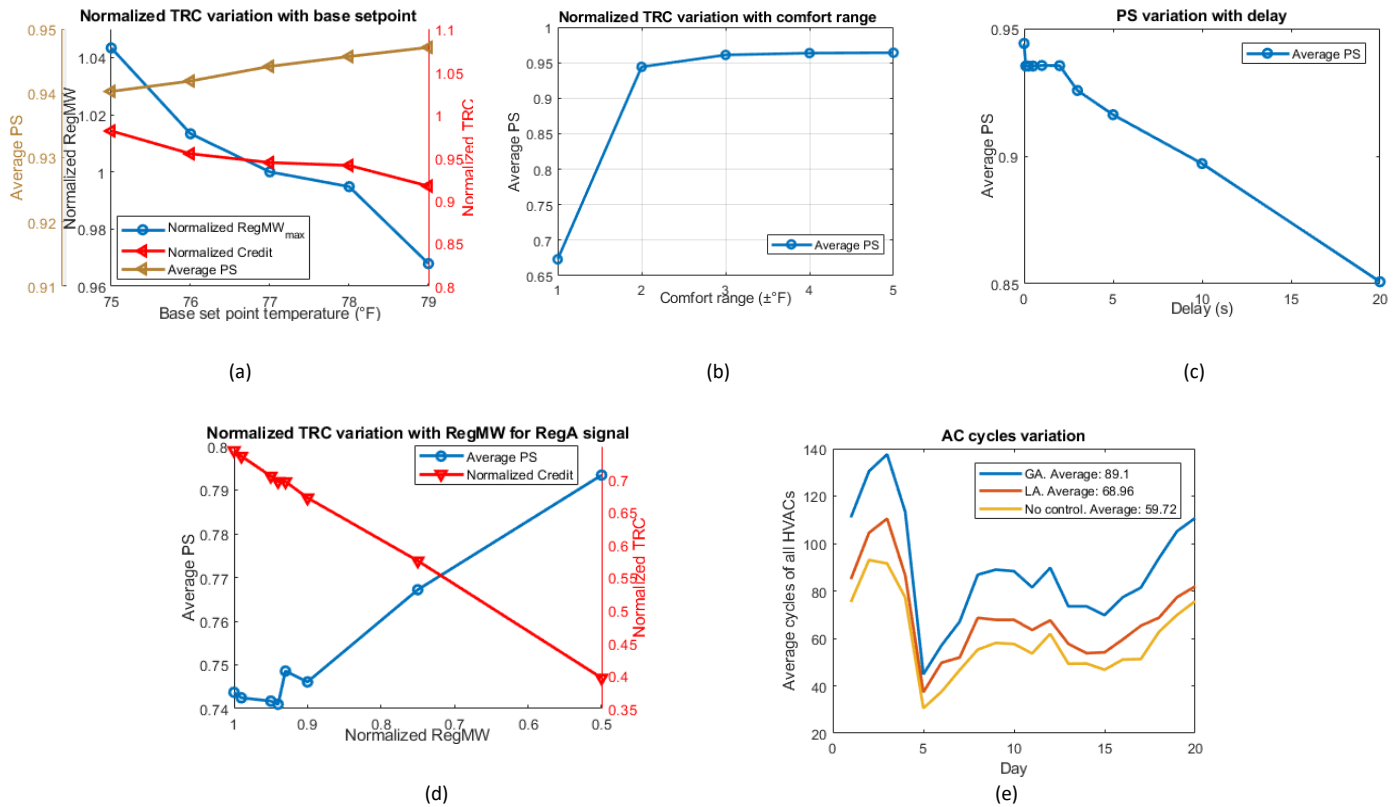

Figure 38 (a) Impact of base set point on regulation credit; (b) Impact of comfort range on PS; (c) Impact of time delay on PS; (d) Average PS and regulation credit variations with RegMW for RegA signals; and (e) Impact of regulation on AC cycling.

temperatures within constraints, if in the preceding time period, they have been turned OFF for a long period of time.

f) Impact on the Number of AC Cycling

One concern while performing DR using HVAC is if the control results in an increased number of AC cycling, thereby reducing the service life of the compressor. Fig. 38(e) shows the average number of daily cycles of all ACs for each of the 20 days, which varies based on the control algorithm used. It can be seen that GA always results in a substantial increase in the average number of AC cycling, but LA results in a much less increase in the AC cycling. This is understandable since LA tends to avoid cycling as much as possible (hence lazy).

g) Summary

The various results of the simulation studies have been summarized in the Table 3. The light blue tags highlight the parameters that are swept, and the orange tags highlights the values that were influenced by that sweep. The dark orange highlights the best result of each sweep.

Table 3 Regulation DR Results summary

Index	Algorithm	RegMW	Base Set point	Comfort Range	Delay	Reg Signal	PS	TRC
1	LA	1.0	77	2	0	D	.944	.944
2	GA	1.0	77	2	0	D	.894	.894
3	LA	1.0	77	2	0	D	.944	.944
4	LA	0.9	77	2	0	D	.958	.862
5	LA	0.75	77	2	0	D	.976	.732
6	LA	1.0	77	2	0	A	.743	.743
7	LA	0.9	77	2	0	A	.746	.672
8	LA	0.75	77	2	0	A	.767	.575
9	LA	1.043	75	2	0	D	.940	.981
10	LA	1	77	2	0	D	.944	.945
11	LA	0.968	79	2	0	D	.947	.916
12	LA	1.0	77	1	0	D	.673	.673
13	LA	1.0	77	2	0	D	.944	.944
14	LA	1.0	77	3	0	D	.961	.961
15	LA	1.0	77	5	0	D	.964	.964
16	LA	1.0	77	2	0	D	.944	.944
17	LA	1.0	77	2	5	D	.916	.916
18	LA	1.0	77	2	10	D	.897	.897

Rows 1-2 indicates that LA has superior performance to GA with RegD. Rows 3-8 indicate that the performance of LA is better with RegD than RegA, and that PS and TRC decrease with the decrease in RegMW. Rows 9-11 illustrate the impact of base set point variation. Rows 12-15 shows the impact of comfort range variations. And, rows 16-18 is for communication delay variation. Base set point of 75°F, comfort range of ±5°F and no communication delay gives the maximum TRC for each of those sweeps.

h) Regulation Credit Estimate for 100 Houses

The final simulation run was conducted using LA, assuming a realistic 2-second communication delay for smart thermostat control, to find the annual TRC that can be expected. The study period was from April 1st to October 31st (214 days, when the AC is in operation). Regulation services were assumed to be provided during all hours when at least 100kW of RegMW could be provided. The CCP, PCP and MR for those time periods was downloaded from PJM. Using (3) TRC was calculated for all those hours, and the result is shown in the heatmap in Figure 39.

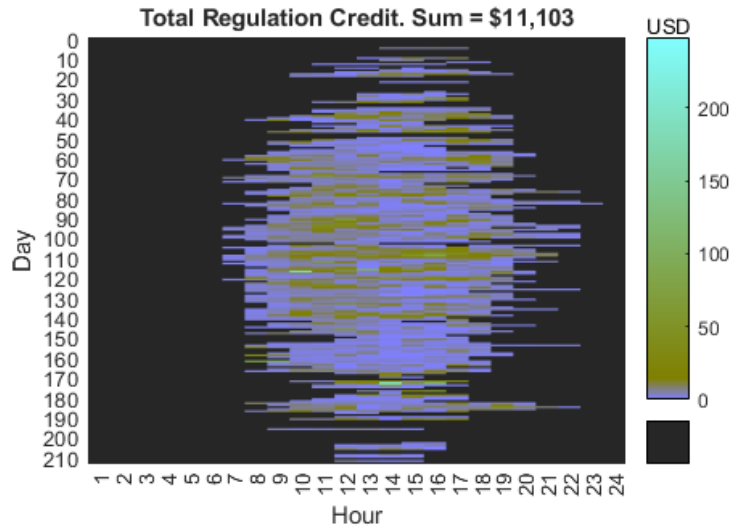

Figure 39 Total regulation credit in dollars. Black areas are hours when the total regulation capacity was less than 100kW and no regulation is provided.

The figure indicates that the credits are low for most hours, but occasionally, credits can be higher than \$100 for some hours. These occur when the CCP and PCP become exceptionally high due to market dynamics. In this study, the total credit added up to \$11,103, effectively averaging out to be about \$111 per house per annum.

i) Conclusion

The LA proposed in this paper was found to be able to provide up to 94.2% performance score while following the real-world RegD signal from the PJM, compared to 89.37% provided by GA. Also, HVAC control is found to be more suitable for RegD signals, providing about 27% more credit than RegA signals. This is understandable since RegD is zero centered and does not require as much energy storage capability in the resource as RegA. An example simulation with 100 houses for the whole year conducted using market clearing price data from PJM showed that a total regulation credit of up to \$11,103 per annum can be obtained. This provides a practical tool for DR aggregators to explore the market for regulation services through an aggregated control of residential HVACs.

4.2 Extensible Residential DR Simulation Framework

4.2.1 House Thermal Behavior and HVAC Operation Simulation Case Study

In order to check the correct operation of the residential thermal and the HVAC module, a single day simulation of a reference house with floor area of 2457 sq. ft. located in Illinois, Chicago weather zone is conducted for a summer month. The thermostat setpoint is kept fixed at 77 degree. Identical simulation is performed in GirdLAB-D with exact same building geometry and properties. For the internal gain, implicit end use devices is used in GridLAB-D, and the exact same implicit end use power profile is fed into the residential simulation module. The comparison between the simulation result between the proposed simulation framework and GridLAB-D shows perfect match, as seen in Figure 40 below:

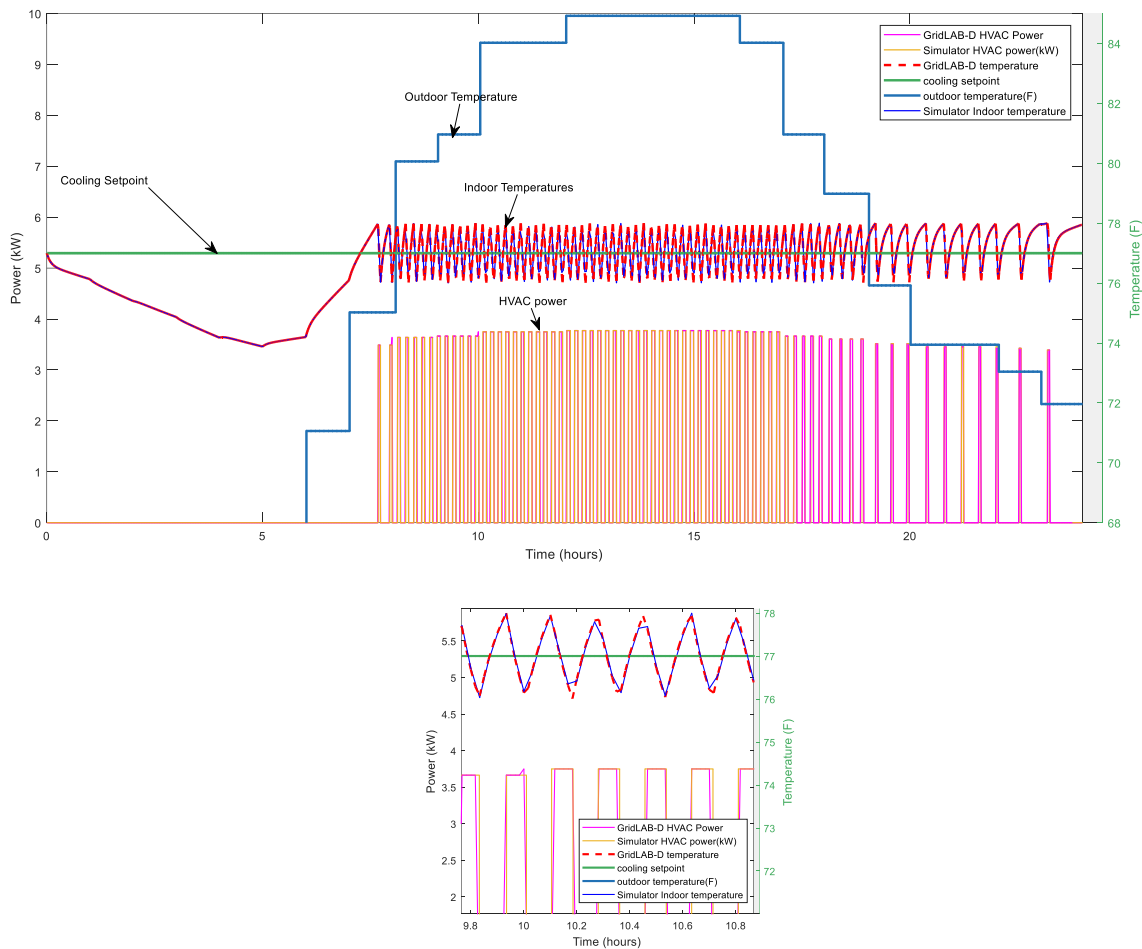

Figure 40: Comparison between the simulation result of the proposed Simulator and GridLAB-D

Hence, the house thermal simulation and the HVAC operation is consistent with what is expected based on their modelling.

4.2.2 Appliance schedule driver

To test the operation of the appliance schedule driver, a simulation of 1000 washers having the individual load-shape as described in section 3.2.2.c is conducted for a duration of 10 days. Also, the aggregated load shape data obtained from [134] is used as the target for the aggregated power profile.

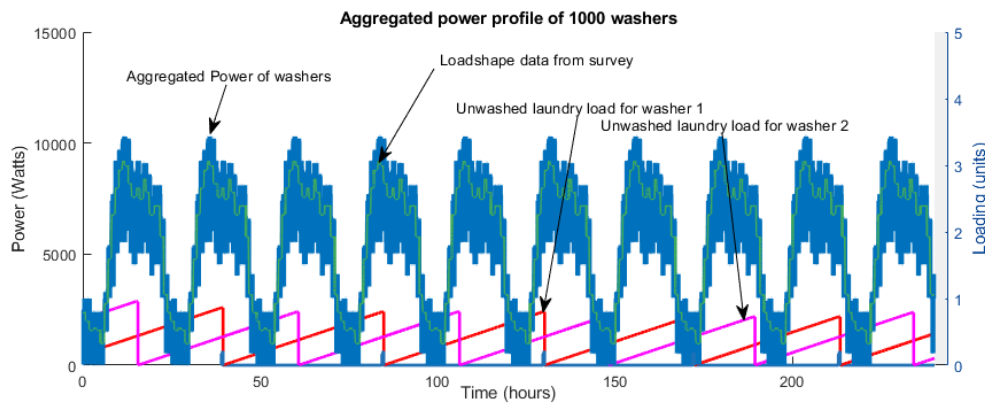

Figure 41: Aggregated power of a collection of clothes washers

As seen the in the Figure 41 above, the aggregated power consumption profile closely follows the load-shape data. And the individual washer behavior is quite realistic, as can be understood by looking at their loading profile. The loading increases linearly and then abruptly jumps down to zero, indicating the operation of the appliance. As can be seen, the appliance is almost always run when the loading is sufficiently high, and is run a few times a week, with higher chance of running during the hours that coincide with the peak of the load-shape data. The fact that the loading doesn't increase to excessive value indicates that the appliance are scheduled sufficiently enough times. Hence, the appliance schedule driver works as expected.

4.2.3 A simple DR implementation with an appliance

The case study in 4.2.2 is extended to study the behavior of the washers when a simple DR event is scheduled. A DR event is scheduled from hour 55 to hour 62. During the DR event, the washers already in operation, continue operating, but for washers which would have otherwise started (based on appliance driver), are delayed until the end of the DR event. As can be seen in the result in Figure 42, the aggregated power has been cleanly limited to almost zero during the DR event time, and after the event, the effect of rebound of the delayed washers can be seen. The aggregated power consumption profile gets influenced for quite some time after the DR event, but it eventually recovers and follows the load-shape as per the appliance driver.

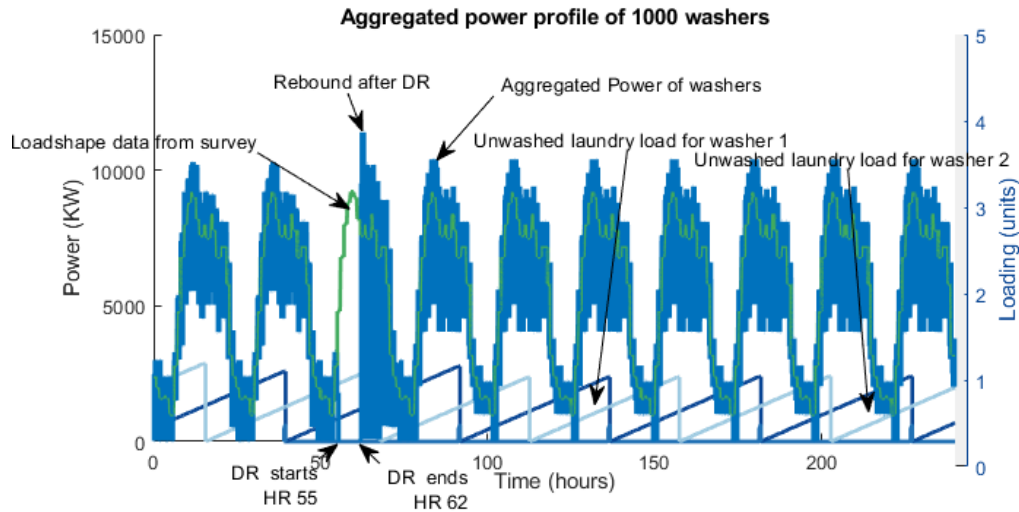

Figure 42: DR event response of a group of clothes washers

4.2.4 Whole house simulation with 1000 houses

```

from ReDreST import ReDreST
from ReDreST.ReDreST import House, DRAuthority, DRAggregator
from ReDreST.definitions import RunType, DRType, ApplianceType, EDType
from ReDreST.writeOutput import OutputData
import random

N=1000
PJM = DRAuthority()
PJM.createDREvent(start_hour=14, end_hour=18, dr_type=DRType.LoadReduction)
PJM.start()
EnerNOC = DRAggregator(dr_authority=PJM)
houses = [House(house_id=i, dr_aggregator=EnerNOC,
                floor_area = random.gauss(2200, 400)) for i in range(N)]
print("Haven't run anything yet")
ReDreST.simulate(start_hr=213*24, end_hr=214*24)

OD = OutputData(axes=[('Power', 'Watts', 0, 5000*N), ('Temp', '(F)', 40, 180)])
OD.addData('Power', 'Total Power (W)', EnerNOC.power_record)
OD.addData('Power', 'Agg Washers Power (W)', ReDreST.washer_aggregator.power_record)
OD.addData('Power', 'Agg Dryers Power (W)', ReDreST.dryer_aggregator.power_record)
OD.addData('Power', 'Agg Dishwasher Power (W)', ReDreST.dishwasher_aggregator.power_record)
OD.addData('Power', 'Agg HVAC Power (W)', ReDreST.hvac_aggregator.power_record)
OD.addData('Power', 'Agg Water heater Power (W)', ReDreST.water_heater_aggregator.power_record)
for i in range(50):
    OD.addData('Temp', 'Water Heateter %i Temperature (F)' % (i,),
              houses[i].appliances[ApplianceType.WaterHeater].temp_record)
    OD.addData('Temp', 'HVAC temp %i Temperature (F)' % (i,),
              houses[i].appliances[ApplianceType.HVAC].temp_record)
OD.addData('Temp', 'Outdoor Temperature (F)',
          ReDreST.inputData.getTSD(EDType.OutdoorTemp, 0, 24), linear_interpolate=True)
OD.writeOutput('redrestresult.rplt', duration_hr=24)

```

Figure 43: Code sample for 1000 house simulation

The code sample above in Figure 43, shows that running a simple DR simulation is very straightforward with the simulation framework. The first step is to import various modules from the library. Then, a DR authority is setup, and a DR event is added. After which, a DR aggregator is created and assigned to the DR authority. Then a list of 1000 houses is created, and the DR aggregator created earlier is bound to those houses. Also, the floor area of the houses are randomly initialized. Various other parameters, such as the house aspect ratio, can be changed, if required, but they would take the default values otherwise. Then, finally, the simulation is run for 24 hours for a particular day.

The bottom section of the code is for generating the required output data. The output data module lets the user choose different output axis, with their label, units and range. Then, different simulation data can be added to each of the axes as required.

The result of running the above code is shown in Figure 44 below:

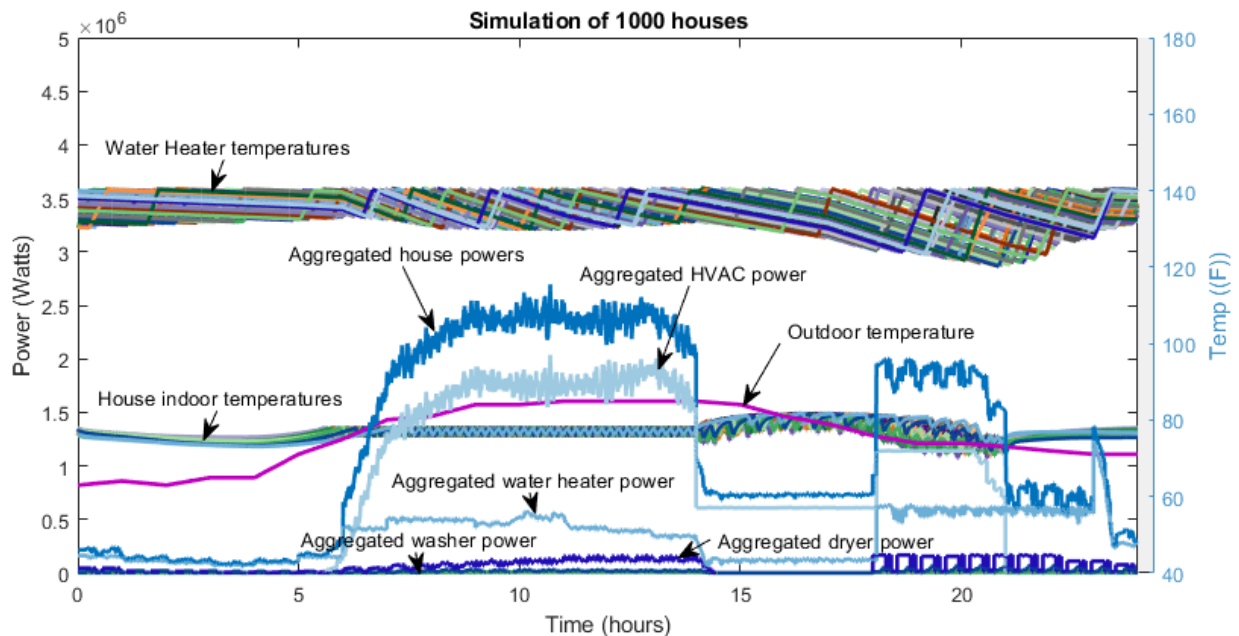

Figure 44: Simulation result for 1000 houses DR

We can see that the result includes all the variables that were selected for output in the OutputData module. The water heater temperature is maintained close to the default setpoint of 140 F. The house temperatures, shown only for 50 out of 1000 houses, is maintained close to the default setpoint of 77 F, except during the DR event hours between 14:00 to 18:00. And, it can be seen that the aggregated power of the whole house, or the individual aggregated power of water heater, HVAC and other appliances, have been reduced during the DR event, showing that the simulation framework is working correctly as expected.

5.0 Conclusion and summary

The dissertation presented two broad solutions for facilitating demand response for residential buildings. The first was a set of algorithms for controlling an aggregation of residential HVACs to provide load reduction and regulation service to the grid. The second was a residential DR simulation framework to enable future research in residential DR.

HVAC are the most energy consuming load in the residential buildings, and also the one that can be controlled with minimal impact on the customer comfort; especially when controlled using intelligent algorithm as the one presented in this dissertation. Hence, HVAC was chosen as the target for the DR algorithms. A set of algorithms were presented for finding the maximum load reduction possible by controlling an aggregation of HVAC devices, and the associated algorithm to control them such that the temperatures are maintained within comfort boundaries. Also, another set of algorithms to control the HVACs such that their aggregated power profile follows a reference regulation signal from ISO were presented for enabling regulation DR.

For a case study with typical scenario, the load reduction algorithm was found to successfully reduce the peak power by up to 60% while keeping indoor temperatures within comfort limits. This is much better than typical set-point based control that reduced the power demand by 26% under the same temperature limits. The algorithm was also shown to be successful in efficiently limiting the DR restrike, a feature not typically available in other approaches.

For another case study, the presented regulation algorithm was found to be able to provide up to 94.2% performance score while following the real-world RegD signal from the PJM. Also, HVAC control is found to be more suitable for RegD signals, providing about 27% more credit than RegA signals. This is understandable since RegD is zero centered and does not require as much energy storage capability in the resource as RegA. An example simulation with 100 houses for the whole year conducted using market clearing price data from PJM showed that a total regulation credit of up to \$11,103 per annum can be obtained.

Since, in terms of hardware, the proposed algorithms only require the presence of IoT-based smart thermostats in buildings, demand aggregators can readily use it without additional infrastructures. This shows a great business opportunity and provides a practical tool for DR aggregators to explore the market for regulation services and load reduction demand response through an aggregated control of residential HVACs.

The residential DR simulation framework presented in this dissertation brings together useful features from various existing tools and solutions, and sews them into a single framework that is

easy to use and extend. It uses the standard second order equivalent thermal parameter model for the residential buildings, and its operation and correctness of operation has been validated against existing standard software tools. The framework has a novel appliance schedule driver which has cleverly maintains realistic load-shape for both individual appliances power profile and their aggregation. This is a great improvement over existing tools that has one or the other feature only.

The contributions of this dissertation can be summarized as follows:

The optimal Load Reduction DR solution consists of:

- A novel linear-time algorithm to find the maximum load reduction potential for an aggregation of houses and associated algorithm to optimally control the HVACs while respecting the comfort requirement.
- Transformation of the HVAC control problem into an intuitive form of job scheduling problem, which provides theoretical clarity to the problem.
- Analytical proof of the optimality of the algorithm.
- Comparison of the performance of the algorithm with existing set-point control based algorithm.
- A complete framework for implementing a residential HVAC control based load reduction DR for DR aggregators, including the process of determining the maximum load reduction capability.

The regulation DR algorithm solution consists of:

- Proof by counter example for why universal optimal regulation algorithm cannot exist.
- A complete framework for implementing a residential HVAC control based regulation service for DR aggregators, including the process of determining the regulation capability.
- A set of real-time heuristic algorithms for controlling the group of HVACs to closely follow the regulation signal that has good performance on wide range of real-world regulation signals.
- Analysis of the impact of communication delay, signal type and homeowner comfort preference on the regulation service based on the performance score calculation method defined by PJM.
- An estimation for the regulation credit obtainable annually by controlling the HVACs of a typical set of 100 residential houses.

The DR Simulation Framework solution consists of:

- An open source residential DR simulation framework, made publicly available in GitHub.

The simulation framework is developed as a importable python library, following object-oriented agent-based design principle which makes customization and extension easy.

- Detailed house thermal model, a wide range of controllable appliance models, and a DR aggregator module.
- A novel appliance usage driver which makes it possible to study appliances at individual level while making their collective load profile match the real-world load-shape data.
- Ability to compare and evaluate different DR algorithms for load control and regulation services.

6.0 Future Work

The HVAC load-reduction presented aggregates only the HVAC load from a collection of residential buildings, without regard to other loads in those buildings. While this is acceptable mechanism of DR for a participant in the PJM wholesale market, the algorithm has potential for higher load reduction (and higher payment), if other controllable house-hold loads (such as the water-heater) are also considered together. This could be a possible direction for future research. Also, a case-study with real-world implementation of the presented algorithm can reveal further limitations of the algorithms and guide research direction.

The regulation algorithm relies solely on controlling the HVAC. While controlling HVAC is the most accessible means of DR and hence the reason for focusing on HVACs, having plug-in electric vehicles or battery storage at homes is becoming more common. Another possible future research direction could be to estimate the regulation capability when HVAC control is combined with battery/inverter system. Also, a large collection of water heater or dryers might be feasible to provide regulation services, and this could be another direction for future research. Also, although the presented regulation algorithm does allow for some delays, a more explicit consideration of the controller processing time delays could be one way to improve on the work presented.

Both the load-reduction and regulation algorithm rely on building thermal information to build the thermal model required to predict their indoor temperature and make control decisions. This time-consuming and error-prone method could be substituted with machine learning based temperature prediction algorithm that builds implicit thermal model internally and can learn and improve with time as new data are obtained. This method can be much more robust as it can evolve with the building, and this could be another direction for future research.

Finally, the residential DR simulation framework can be extended by adding many more appliances such as the microwave oven, electric range, electric vehicles, TVs, lights etc. The appliance schedule driver does make the aggregated power consumption profile of appliances match the real-world load-shape data while still doing individual on/off control of appliances (as opposed to making their power vary continuously), it still doesn't fully consider the relationship of appliance uses with household size. For example, larger households are more likely to use the clothes washer more frequently than smaller households. There is room for future work in making the appliance usage even more realistic by considering those aspects.

7.0 Appendix

Consider the transformed view of the problem in Figure 45, copied below in Figure 33 for easy referencing:

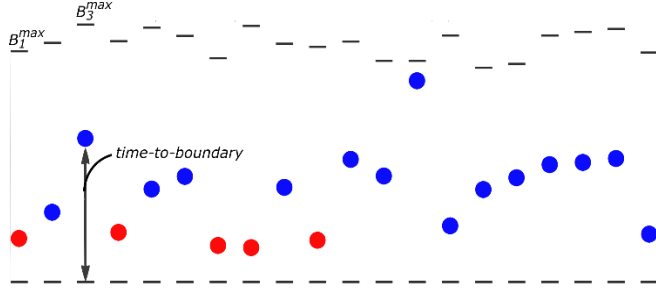

Figure 45: Transformation of the problem to represent the time-to-boundary as the height of each ball

Without loss of generality, let us assume that the control period (T) from t_{start} to t_{end} be divided into Z intervals of length L , which is assumed 5 minutes, so that $Z = T/L$, as shown in Figure 46. During each control period, JA selects a subset of HVACs to run according to Algorithm 2.

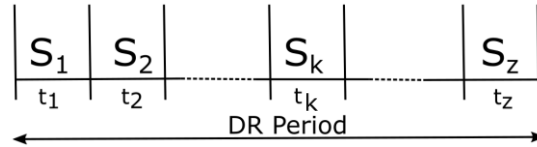

Figure 46: Dividing the DR periods into z intervals

At the beginning of k^{th} control period, the *time-to-boundary* for HVAC n that has previously been ran x times can be obtained as:

$$B_n^k = B_n^1 + D_n * x - L * (k - 1 - x) = g_n(k, x) \quad \forall n \quad (\text{A1})$$

Where,

B_n^k is the *time-to-boundary* for the HVAC n , at the beginning of control period k

B_n^1 is the *time-to-boundary* for the HVAC n , at the beginning of DR event

D_n is the time by which the *time-to-boundary* of HVAC $_n$ is delayed when it is controlled in a control period (defined in Algorithm 2)

x is the number of times HVAC $_n$ has already run by the k^{th} control period

L is the control period length (5-minutes)

The objective is to ensure that, at all control periods, indoor temperatures of all houses are within the bounds, which is equivalent to ensuring that

$$0 \leq B_n^k \leq B_n^{max} \quad \text{for } 1 \leq k \leq Z + 1$$

This enables us to reformulate this problem as a job scheduling problem [140]. Let us define a job J_n^i as the task of running HVAC n for the i -th time. The job J_n^i can be delayed until the time to

boundary for HVAC n would become negative. Hence, the deadline ($d_{J_n^i}$) for job J_n^i can be obtained as:

$$d_{J_n^i} = \max_k g_n(k, i - 1) > 0$$

$$d_{J_n^i} = \left\lfloor \frac{B_n^{t_1} + (D_n + L) * (i - 1) + L}{L} \right\rfloor$$

$x = i - 1$ is used in the above equation because, for HVAC to be run for the i^{th} time, it must have had run for $i - 1$ times before.

Similarly, the job J_n^i can be scheduled as soon as its time to boundary does not exceed B_n^{max} when controlled. That is, the release time ($r_{J_n^i}$) can be obtained as:

$$r_{J_n^i} = \min_k g_n(k, i - 1) + D_n \leq B_n^{\text{max}}$$

$$r_{J_n^i} = \left\lfloor \frac{B_n^{t_1} + (D_n + L) * i - B_n^{\text{max}}}{L} \right\rfloor$$

Hence, the deadlines and release times for J_n^i is fixed and independent of how other jobs are scheduled. That is the window of time during which a HVAC needs to be operated for the i^{th} time is independent of when its history of operation. The only constraint is the precedence constraints where Job J_n^i must occur strictly before job J_n^{i+1} (which is just to say that an HVAC must be run for i^{th} time before running it for $i+1^{\text{th}}$ time).

It should be noted that a feasible schedule is an optimal schedule in our case, because if the optimal schedule were to finish scheduling the jobs earlier than the feasible schedule, the number of parallel jobs would be decreased in the next iteration of the Algorithm 1 and so-on until only the optimal schedule remains feasible. In rest of the appendix, feasible and optimal is used interchangeably when talking about the schedule.

Now, let the set of jobs selected to run during some control interval i by the optimal scheduling algorithm (O) be O_i , and that by the proposed JA (A) be A_i .

Let JA agree with the optimal algorithm for up to some control period k such that $0 \leq k < n$. That is,

$$O_i = A_i \text{ for } i < k$$

$$O_i \neq A_i \text{ for } i = k$$

Let G jobs be scheduled during the interval k by the optimal algorithm and be given by:

$$O_k = \{O_{k,1}, O_{k,2}, \dots, O_{k,G}\}$$

And let F jobs be scheduled during the interval k by JA and be given by:

$$A_k = \{A_{k,1}, A_{k,2}, \dots, A_{k,F}\}$$

These jobs are sorted in the ascending order of their *deadlines*. Note that $F \neq G$ since the number of jobs scheduled during each control period by the algorithms can be different because of different weights. Also, it is straightforward to show that JA as defined in Section III is equivalent to selecting jobs with earliest deadlines that have been released such that the sum of their weight is just less than the demand limit. It is assumed that for all k , due to the weight constraint, there is no more room for any other job in A_k .

The algorithm A is now proved to be optimal using an exchange argument [141], which is a proof technique where a test algorithm is proved optimal by gradually modifying the optimal algorithm and finally making it the same as the test algorithm, and never losing the optimality in the process. Below, it is shown that the optimal algorithm can be modified into the JA without losing its optimality.

Let $A_k - O_k = \{A_{k,j}, A_{k,j+1}, \dots, A_{k,F}\} = \{J_{p_j}^{x_j}, J_{p_{j+1}}^{x_{j+1}}, \dots, J_{p_F}^{x_F}\}$ (Jobs in A_k but not in O_k)

And $O_k - A_k = \{O_{k,j}, O_{k,j+1}, \dots, O_{k,G}\} = \{J_{q_j}^{y_j}, J_{q_{j+1}}^{y_{j+1}}, \dots, J_{q_G}^{y_G}\}$ (Jobs in O_k but not in A_k)

... sorted in the ascending order of their *deadlines*.

$A_k - O_k$ cannot be empty because if O_k contains all jobs of A_k then it cannot have any space for more jobs and it would be exactly equal to A_k negating our presumption of that $O_i \neq A_i$ for $i = k$. $O_k - A_k$ can be empty, though.

Let us assume that $J_{p_\alpha}^{x_\alpha}$, the job of running HVAC p_α for x_α th time, (for all $j \leq \alpha \leq F$ and $J_{p_\alpha}^{x_\alpha} \in \{A_k - O_k\}$) occurs at some later time at $t=r_\alpha$ at O . Or, it does not occur at all in O . For example, $J_{p_F}^{x_F}$ if present, occurs at $t=r_F$. If it does not exist, it is assumed to exist after the control period, so that $r_F = Z+1$.

Assume that for HVAC q_β (for all $j \leq \beta \leq G$), there are v_β number of jobs that occur between time $k \leq t < r_F$ in O . These jobs occur at times $t = s_\gamma$ (for all $0 \leq \gamma < v_\beta$) and are denoted by $J_{q_\beta}^{y_\beta + \gamma}$. This includes the job $J_{q_\beta}^{y_\beta}$ at $t=k$, and this means $s_0 = k$ (because $J_{q_\beta}^{y_\beta + 0}$ is assumed to run at $t = s_0$). It is possible that $v_\beta = 1$, which means only $J_{q_\beta}^{y_\beta}$ job occurs for HVAC q_β in O after time k , or in other words, HVAC q_β runs for the final time at $t=k$ in O .

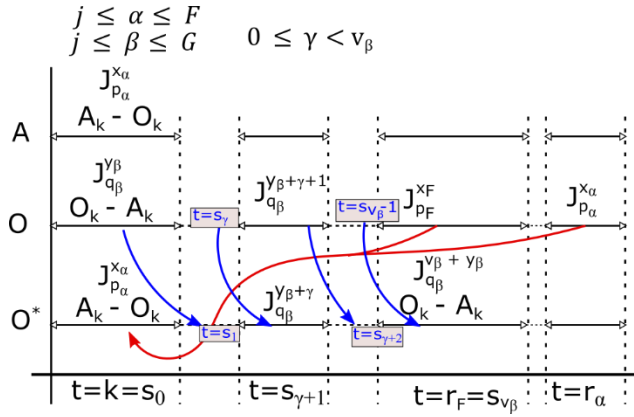

Figure 47: Illustration of the exchange step at time step $t=k$

Now, create a new schedule O^* by modifying the schedule O as illustrated in the Figure 47. The jobs in $A_k - O_k$ are moved from various places in O (if they exist in O) to $t = k$ in O^* (illustrated by the red line in Figure 47). If any of the jobs in $A_k - O_k$ does not exist in O , they are simply created at $t = k$ at O^* (instead of moving).

All the jobs $J_{q_\beta}^{y_{\beta+\gamma}}$ are moved from $t = s_\gamma$ in O to $t = s_{\gamma+1}$ in O^* and s_{v_β} is defined to be equal to r_F .

It is next shown that these changes still ensure that all jobs are run after release times and before deadlines in O^* (if it does in O , and it should since it is assumed to be an optimal (feasible) algorithm).

The jobs $A_k - O_k$ are run before deadline in O^* at $t = k$, since they were run later than $t = k$ (or not run at all) in O . Also, they will run after release in O^* since, they run in A at $t = k$, and A only runs jobs after their release time.

Jobs $J_{q_\beta}^{y_\beta}$ have deadline later than any jobs in A_k because $J_{q_\beta}^{y_\beta}$ are not present in A_k and A_k has jobs with earliest deadlines that are released by $t = k$ (and $J_{q_\beta}^{y_\beta}$ are released by $t = k$ since they are present in O_k). Job $J_{p_F}^{x_F}$ is in A_k and it runs at $t = r_F$ in O_k , so jobs $J_{q_\beta}^{y_\beta}$ must have deadline after $t = r_F$. Since for any job $d_{j+1} > d_{j_i}$, all jobs $J_{q_\beta}^{y_{\beta+\gamma}}$ have deadline after $t = r_F$ and are guaranteed to run before deadline in O^* since they are run at or before $t = r_F$.

Also all jobs $J_{q_\beta}^{y_{\beta+\gamma}}$ are run later in O^* than in O , so they are guaranteed to be run after release.

Since all other jobs in O are left unaffected in O^* , they must continue to run before deadline and after release. Hence, O^* is still feasible schedule.

When this process is completed:

$$O_i^* = A_i \text{ for } i \leq k$$

$$O_i^* \neq A_i \text{ for } i = k + 1$$

That is, O^* agrees with A for one more time step than O , and O^* still runs all jobs before deadline and after release time. This procedure can then be repeated for all future time steps,

such that $O_i^* = A_i$ for all i , which means $O^* = A$. Since O^* always remains feasible, finally when O^* becomes equal to A , it should remain feasible and also meet the weight constraint because A does. It was argued before that a feasible algorithm is optimal in our case. This concludes the proof that A is optimal.

8.0 References

- [1] Gilstrap and Matt, "United States Electricity Industry Primer," 2015.
- [2] "PJM 101 The Basics," 2017. [Online]. Available: <http://www.pjm.com/training/~/media/2F50B2D760BF44F1BC7C5A2A42EA2D2A.ashx>. [Accessed: 19-Feb-2018].
- [3] "U.S. Energy Information Administration." [Online]. Available: <http://buildingsdatabook.eren.doe.gov/TableView.aspx?table=1.1.3>. [Accessed: 17-Jul-2016].
- [4] SmartGrid Consumer Collaborative, "Consumer Pulse and Market Segment Study-Wave 6," 2017.
- [5] K. Gillingham, R. Newell, and K. Palmer, *Retrospective examination of demand-side energy efficiency policies*. 2004.
- [6] C. W. Gellings, "The concept of demand-side management for electric utilities," *Proc. IEEE*, vol. 73, no. 10, pp. 1468–1470, 1985.
- [7] K. Spees and L. Lave, "Demand response and electricity market efficiency," *Electr. J.*, 2007.
- [8] Q. Qdr, "Benefits of demand response in electricity markets and recommendations for achieving them," *US Dep. energy*, 2006.
- [9] Q. Qdr, "Benefits of demand response in electricity markets and recommendations for achieving them," 2006.
- [10] "Comed R RTP." [Online]. Available: <https://www.comed.com/documents/customer-service/rates-pricing/real-time-pricing/rrtpprogramguide.pdf?FileTracked=true>. [Accessed: 25-Oct-2015].
- [11] "Prices - Power Smart Pricing." [Online]. Available: <https://www.powersmartpricing.org/prices/>. [Accessed: 01-Mar-2018].
- [12] "PGE Time-of-Use rate plans." [Online]. Available: https://www.pge.com/en_US/residential/rate-plans/rate-plan-options/time-of-use-base-plan/not-enrolled.page. [Accessed: 01-Mar-2018].
- [13] "Time of Use Plus (Critical Peak Pricing- CPP-D) | San Diego Gas & Electric." [Online]. Available: <https://www.sdge.com/business/demand-response/cpp>. [Accessed: 01-Mar-2018].
- [14] "ClearlyEnergy Residential Direct Load Control Programs." [Online]. Available: <https://www.clearlyenergy.com/residential-demand-response-programs>. [Accessed: 01-Mar-2018].
- [15] "Entergy Arkansas, Inc. - Summer Advantage Program." [Online]. Available: http://www.energy-arkansas.com/your_home/save_money/EE/summer-advantage.aspx. [Accessed: 01-Mar-2018].
- [16] "Base Interruptible Program | San Diego Gas & Electric." [Online]. Available: <https://www.sdge.com/business/bip>. [Accessed: 01-Mar-2018].
- [17] "Capacity Bidding Program | San Diego Gas & Electric." [Online]. Available: <https://www.sdge.com/business/demand-response/capacitybidding>. [Accessed: 01-Mar-2018].
- [18] FERC, "2017 Assessment of Demand Response and Advanced Metering," 2017.
- [19] *PJM Manual 18: Capacity Market*. 2017.
- [20] PJM, "PJM Manual 11: Energy & Ancillary Services Market Operations," 2017. [Online]. Available: <http://www.pjm.com/~/media/documents/manuals/m11.ashx>. [Accessed: 22-Feb-2018].
- [21] "Demand Response (and PRD) Opportunities in PJM Wholesale Markets."
- [22] "2018 Demand Response Operations Markets Activity Report: February 2018 James McAnany PJM Demand Side Response Operations," 2018.
- [23] "PJM - Curtailment Service Providers." [Online]. Available: <http://www.pjm.com/markets-and-operations/demand-response/csps.aspx>. [Accessed: 01-Mar-2018].
- [24] J. S. Vardakas, N. Zorba, and C. V. Verikoukis, "A Survey on Demand Response Programs in Smart Grids: Pricing Methods and Optimization Algorithms," *IEEE Commun. Surv. Tutorials*, vol. 17, no. 1, pp. 152–178, 2015.
- [25] M. Albadi and E. El-Saadany, "A summary of demand response in electricity markets," *Electr. power Syst. Res.*, vol. 78, no. 11, pp. 1989–1996, 2008.
- [26] P. Siano, "Demand response and smart grids—A survey," *Renew. Sustain. Energy Rev.*, vol. 30, pp. 461–478, 2014.
- [27] N. G. Paterakis, O. Erdinc, and J. P. S. Catalão, "An overview of Demand Response: Key-elements and international experience," *Renew. Sustain. Energy Rev.*, vol. 69, pp. 871–891, Mar. 2017.
- [28] M. Rastegar, M. Fotuhi-Firuzabad, and F. Aminifar, "Load commitment in a smart home," *Appl. Energy*, vol. 96, pp. 45–54, Aug. 2012.
- [29] J. Lee, G.-L. Park, S.-W. Kim, H.-J. Kim, and C. O. Sung, "Power consumption scheduling for peak load reduction in smart grid homes," in *Proceedings of the 2011 ACM Symposium on Applied Computing*, 2011.
- [30] M. Pipattanasomporn, M. Kuzlu, and S. Rahman, "An Algorithm for Intelligent Home Energy Management and Demand Response Analysis," *IEEE Trans. Smart Grid*, vol. 3, no. 4, pp. 2166–2173, Dec. 2012.
- [31] A.-H. Mohsenian-Rad and A. Leon-Garcia, "Optimal Residential Load Control With Price Prediction in Real-Time Electricity Pricing Environments," *IEEE Trans. Smart Grid*, vol. 1, no. 2, pp. 120–133, Sep. 2010.
- [32] P. Du and N. Lu, "Appliance Commitment for Household Load Scheduling," *IEEE Trans. Smart Grid*, vol. 2, no. 2, pp. 411–419, Jun. 2011.
- [33] N. Gatsis and G. B. Giannakis, "Residential demand response with interruptible tasks: Duality and algorithms," in *IEEE Conference on Decision and Control and European Control Conference*, 2011, pp. 1–6.
- [34] M. Behrangrad, H. Sugihara, and T. Funaki, "Analyzing the system effects of optimal demand response utilization for reserve procurement and peak clipping," in *IEEE PES General Meeting*, 2010, pp. 1–7.
- [35] Y. Guo, M. Pan, and Y. Fang, "Optimal Power Management of Residential Customers in the Smart Grid," *IEEE Trans. Parallel Distrib. Syst.*, vol. 23, no. 9, pp. 1593–1606, Sep. 2012.
- [36] K. M. Tsui and S. C. Chan, "Demand Response Optimization for Smart Home Scheduling Under Real-Time Pricing," *IEEE Trans. Smart Grid*, vol. 3, no. 4, pp. 1812–1821, Dec. 2012.
- [37] T. Logenthiran, D. Srinivasan, and T. Z. Shun, "Demand Side Management in Smart Grid Using Heuristic Optimization," *IEEE Trans. Smart Grid*, vol. 3, no. 3, pp. 1244–1252, Sep. 2012.
- [38] Jin Xiao, Jae Yoon Chung, Jian Li, R. Boutaba, and J. Won-Ki Hong, "Near optimal demand-side energy management under real-time demand-response pricing," in *2010 International Conference on Network and Service Management*, 2010, pp. 527–532.
- [39] J. Cao, B. Yang, C. Chen, X. G.-C. C. (CCC), and U. 2012, "Optimal demand response using mechanism design in the smart grid," in

- Proceedings of the 31st Chinese Control Conference, 2012.*
- [40] L. Jiang and S. H. Low, "Multi-period Optimal Procurement and Demand Responses in the Presence of Uncertain Supply," in *Proceedings of IEEE Conference on Decision and Control (CDC)*, 2011.
- [41] S. Li, W. Zhang, J. Lian, and K. Kalsi, "Market-Based Coordination of Thermostatically Controlled Loads—Part I: A Mechanism Design Formulation," *IEEE Trans. Power Syst.*, vol. 31, no. 2, pp. 1170–1178, Mar. 2016.
- [42] Z. Zhu, J. Tang, ... S. L.-I. S. G., and undefined 2012, "An integer linear programming based optimization for home demand-side management in smart grid," *ieeexplore.ieee.org*.
- [43] C. N. Kurucz, D. Brandt, and S. Sim, "A linear programming model for reducing system peak through customer load control programs," *IEEE Trans. Power Syst.*, vol. 11, no. 4, pp. 1817–1824, 1996.
- [44] R. Adhikari, M. Pipattanasomporn, and S. Rahman, "An algorithm for optimal management of aggregated HVAC power demand using smart thermostats," *Appl. Energy*, vol. 217, pp. 166–177, May 2018.
- [45] P. Palensky and D. Dietrich, "Demand Side Management: Demand Response, Intelligent Energy Systems, and Smart Loads," *IEEE Trans. Ind. Informatics*, vol. 7, no. 3, pp. 381–388, Aug. 2011.
- [46] T. Samad and S. Kiliccote, "Smart grid technologies and applications for the industrial sector," *Comput. Chem. Eng.*, vol. 47, pp. 76–84, 2012.
- [47] K. Bhattacharyya and M. L. Crow, "A fuzzy logic based approach to direct load control," *IEEE Trans. Power Syst.*, vol. 11, no. 2, pp. 708–714, May 1996.
- [48] A. Molina, A. Gabaldon, J. A. Fuentes, and F. J. Canovas, "Approach to multivariable predictive control applications in residential HVAC direct load control," in *Power Engineering Society Summer Meeting (Cat. No.00CH37134)*, 2000, vol. 3, pp. 1811–1816.
- [49] C. Chi-Min, J. Tai-Long, and H. Yue-Wei, "A direct load control of air-conditioning loads with thermal comfort control," in *Power Engineering Society General Meeting, 2005. IEEE, 2005*, p. 664–669 Vol. 1.
- [50] T. Tran-Quoc, J. Sabonnadiere, N. Hadjsaid, and C. Kiemy, "Air conditioner direct load control in distribution networks," in *2009 IEEE Bucharest PowerTech*, 2009, pp. 1–6.
- [51] S. Katipamula and N. Lu, "Evaluation of Residential HVAC Control Strategies for Demand Response Programs (SYMPOSIUM PAPERS - CH-06-7 Demand Response Strategies for Building Systems)," *ASHRAE Trans.*, no. 112(1):535, pp. 1–12, 2006.
- [52] J. C. Fuller, K. P. Schneider, and D. Chassin, "Analysis of Residential Demand Response and double-auction markets," in *2011 IEEE Power and Energy Society General Meeting*, 2011, pp. 1–7.
- [53] K. P. Schneider, J. C. Fuller, and D. Chassin, "Analysis of distribution level residential demand response," *2011 IEEE/PES Power Syst. Conf. Expo. PSCC 2011*, pp. 1–6, 2011.
- [54] R. Adhikari, M. Pipattanasomporn, M. Kuzlu, and S. Rahman, "Simulation study of transactive control strategies for residential HVAC systems," in *2016 IEEE PES Innovative Smart Grid Technologies Conference Europe (ISGT-Europe)*, 2016, pp. 1–5.
- [55] A.-H. Mohsenian-Rad, V. W. S. Wong, J. Jatskevich, and R. Schober, "Optimal and autonomous incentive-based energy consumption scheduling algorithm for smart grid," in *2010 Innovative Smart Grid Technologies (ISGT)*, 2010, pp. 1–6.
- [56] A.-H. Mohsenian-Rad and A. Leon-Garcia, "Optimal Residential Load Control With Price Prediction in Real-Time Electricity Pricing Environments," *IEEE Trans. Smart Grid*, vol. 1, no. 2, pp. 120–133, Sep. 2010.
- [57] Jidong Wang, Zhiqing Sun, Yue Zhou, and Jiaqiang Dai, "Optimal dispatching model of Smart Home Energy Management System," in *IEEE PES Innovative Smart Grid Technologies*, 2012, pp. 1–5.
- [58] D. Zhang, S. Li, M. Sun, and Z. O'Neill, "An Optimal and Learning-Based Demand Response and Home Energy Management System," *IEEE Trans. Smart Grid*, vol. 7, no. 4, pp. 1790–1801, Jul. 2016.
- [59] J. H. Yoon, R. Bladick, and A. Novoselac, "Demand response for residential buildings based on dynamic price of electricity," *Energy Build.*, vol. 80, pp. 531–541, Sep. 2014.
- [60] W. Zhang, J. Lian, C.-Y. Chang, and K. Kalsi, "Aggregated Modeling and Control of Air Conditioning Loads for Demand Response," *IEEE Trans. Power Syst.*, vol. 28, no. 4, pp. 4655–4664, Nov. 2013.
- [61] N. Lu, "An Evaluation of the HVAC Load Potential for Providing Load Balancing Service," *IEEE Trans. Smart Grid*, vol. 3, no. 3, pp. 1263–1270, Sep. 2012.
- [62] E. Vrettos, S. Koch, and G. Andersson, "Load frequency control by aggregations of thermally stratified electric water heaters," in *2012 3rd IEEE PES Innovative Smart Grid Technologies Europe (ISGT Europe)*, 2012, pp. 1–8.
- [63] J. L. Mathieu, S. Koch, and D. S. Callaway, "State Estimation and Control of Electric Loads to Manage Real-Time Energy Imbalance," *IEEE Trans. Power Syst.*, vol. 28, no. 1, pp. 430–440, Feb. 2013.
- [64] H. Hao, B. M. Sanandaji, K. Poolla, and T. L. Vincent, "Aggregate Flexibility of Thermostatically Controlled Loads," *IEEE Trans. Power Syst.*, vol. 30, no. 1, pp. 189–198, Jan. 2015.
- [65] S. Parkinson, D. Wang, C. Crawford, and N. Djilali, "Comfort-Constrained Distributed Heat Pump Management," *Energy Procedia*, vol. 12, pp. 849–855, 2011.
- [66] C. Joe-Wong, S. Sen, S. Ha, and M. Chiang, "Optimized Day-Ahead Pricing for Smart Grids with Device-Specific Scheduling Flexibility," *IEEE J. Sel. Areas Commun.*, vol. 30, no. 6, pp. 1075–1085, Jul. 2012.
- [67] Ziming Zhu, Jie Tang, S. Lambotharan, Woon Hau Chin, and Zhong Fan, "An integer linear programming based optimization for home demand-side management in smart grid," in *2012 IEEE PES Innovative Smart Grid Technologies (ISGT)*, 2012, pp. 1–5.
- [68] N. Li, L. Chen, and S. H. Low, "Optimal demand response based on utility maximization in power networks," in *2011 IEEE Power and Energy Society General Meeting*, 2011, pp. 1–8.
- [69] E. Reihani, S. Sepasi, and R. Ghorbani, "Scheduling of price-sensitive residential storage devices and loads with thermal inertia in distribution grid," *Appl. Energy*, vol. 183, pp. 636–644, Dec. 2016.
- [70] W. J. Cole, J. D. Rhodes, W. Gorman, K. X. Perez, M. E. Webber, and T. F. Edgar, "Community-scale residential air conditioning control for effective grid management," *Appl. Energy*, vol. 130, pp. 428–436, Oct. 2014.
- [71] G. Bianchini, M. Casini, A. Vicino, and D. Zarrilli, "Demand-response in building heating systems: A Model Predictive Control approach," *Appl. Energy*, vol. 168, pp. 159–170, Apr. 2016.
- [72] M. Liu and Y. Shi, "Model Predictive Control for Thermostatically Controlled Appliances Providing Balancing Service," *IEEE Trans.*

- Control Syst. Technol.*, vol. 24, no. 6, pp. 2082–2093, Nov. 2016.
- [73] Y. Zhou, C. Wang, J. Wu, J. Wang, M. Cheng, and G. Li, "Optimal scheduling of aggregated thermostatically controlled loads with renewable generation in the intraday electricity market," *Appl. Energy*, vol. 188, pp. 456–465, Feb. 2017.
- [74] S. Nan, M. Zhou, and G. Li, "Optimal residential community demand response scheduling in smart grid," *Appl. Energy*, vol. 210, pp. 1280–1289, Jan. 2018.
- [75] S. Behboodi, D. P. Chassin, N. Djilali, and C. Crawford, "Transactive control of fast-acting demand response based on thermostatic loads in real-time retail electricity markets," *Appl. Energy*, vol. 210, pp. 1310–1320, Jan. 2018.
- [76] D. P. Chassin and D. Rondeau, "Aggregate modeling of fast-acting demand response and control under real-time pricing," *Appl. Energy*, vol. 181, pp. 288–298, Nov. 2016.
- [77] K. Ma, C. Yuan, J. Yang, J. Li, S. Hu, and Y. Wang, "Controller design and parameter optimization of aggregated thermostatically controlled loads for frequency regulation," in *2016 35th Chinese Control Conference (CCC)*, 2016, pp. 10035–10040.
- [78] M. Liu and Y. Shi, "Model Predictive Control of Aggregated Heterogeneous Second-Order Thermostatically Controlled Loads for Ancillary Services," *IEEE Trans. Power Syst.*, vol. 31, no. 3, pp. 1963–1971, May 2016.
- [79] O. Erdinc, A. Tascikaraoglu, N. G. Paterakis, Y. Eren, and J. P. S. Catalao, "End-User Comfort Oriented Day-Ahead Planning for Responsive Residential HVAC Demand Aggregation Considering Weather Forecasts," *IEEE Trans. Smart Grid*, vol. 8, no. 1, pp. 362–372, Jan. 2017.
- [80] N. A. Sinityn, S. Kundu, and S. Backhaus, "Safe protocols for generating power pulses with heterogeneous populations of thermostatically controlled loads," *Energy Convers. Manag.*, vol. 67, pp. 297–308, Mar. 2013.
- [81] N. Lu and Y. Zhang, "Design Considerations of a Centralized Load Controller Using Thermostatically Controlled Appliances for Continuous Regulation Reserves," *IEEE Trans. Smart Grid*, vol. 4, no. 2, pp. 914–921, Jun. 2013.
- [82] M. Vanouni and N. Lu, "Improving the Centralized Control of Thermostatically Controlled Appliances by Obtaining the Right Information," *IEEE Trans. Smart Grid*, vol. 6, no. 2, pp. 946–948, Mar. 2015.
- [83] M. Ali, M. Humayun, M. Degefa, A. Alahaivala, M. Lehtonen, and A. Safdarian, "A framework for activating residential HVAC demand response for wind generation balancing," in *2015 IEEE Innovative Smart Grid Technologies - Asia (ISGT ASIA)*, 2015, pp. 1–6.
- [84] M. T. Muhssin, L. Cipcigan, N. Jenkins, S. Slater, M. Cheng, and Z. Obaid, "Dynamic Frequency Response from Controlled Domestic Heat Pumps," *IEEE Trans. Power Syst.*, pp. 1–1, 2018.
- [85] J. Hu *et al.*, "Load Following of Multiple Heterogeneous TCL Aggregators by Centralized Control," *IEEE Trans. Power Syst.*, vol. 32, no. 4, pp. 3157–3167, Jul. 2017.
- [86] K. Ma, C. Yuan, J. Yang, J. Li, S. Hu, and Y. Wang, "Controller design and parameter optimization of aggregated thermostatically controlled loads for frequency regulation," in *2016 35th Chinese Control Conference (CCC)*, 2016, pp. 10035–10040.
- [87] C. Li, Y. Chen, F. Luo, Z. Xu, and Y. Zheng, "Real-Time Decision Making Model for Thermostatically Controlled Load Aggregators by Natural Aggregation Algorithm," in *2017 IEEE International Conference on Energy Internet (ICEI)*, 2017, pp. 279–284.
- [88] Y. Lin, P. Barooah, S. Meyn, and T. Middelkoop, "Experimental Evaluation of Frequency Regulation From Commercial Building HVAC Systems," *IEEE Trans. Smart Grid*, vol. 6, no. 2, pp. 776–783, Mar. 2015.
- [89] I. Beil, I. Hiskens, and S. Backhaus, "Frequency Regulation From Commercial Building HVAC Demand Response," *Proc. IEEE*, vol. 104, no. 4, pp. 745–757, Apr. 2016.
- [90] B. M. Sanandaji, T. L. Vincent, and K. Poola, "Ramping Rate Flexibility of Residential HVAC Loads," *IEEE Trans. Sustain. Energy*, vol. 7, no. 2, pp. 865–874, Apr. 2016.
- [91] M. Ghanavati and A. Chakravarthy, "Demand-Side Energy Management by Use of a Design-Then-Approximate Controller for Aggregated Thermostatic Loads," *IEEE Trans. Control Syst. Technol.*, pp. 1–10, 2017.
- [92] H. Hao, T. Middelkoop, P. Barooah, and S. Meyn, "How demand response from commercial buildings will provide the regulation needs of the grid," in *2012 50th Annual Allerton Conference on Communication, Control, and Computing (Allerton)*, 2012, pp. 1908–1913.
- [93] K. Dehghanpour and S. Afsharnia, "Electrical demand side contribution to frequency control in power systems: a review on technical aspects," *Renew. Sustain. Energy Rev.*, vol. 41, pp. 1267–1276, Jan. 2015.
- [94] M. Liu and Y. Shi, "Optimal control of aggregated heterogeneous thermostatically controlled loads for regulation services," in *2015 54th IEEE Conference on Decision and Control (CDC)*, 2015, pp. 5871–5876.
- [95] Yu-Qing Bao, Jia-Qi Ju, Qi Wang, and Gang Ma, "On the accuracy of the state-queueing model for the thermostatically controlled loads," in *2016 IEEE PES Asia-Pacific Power and Energy Engineering Conference (APPEEC)*, 2016, pp. 1990–1994.
- [96] "EnergyPlus | EnergyPlus." [Online]. Available: <https://energyplus.net/>. [Accessed: 07-Mar-2018].
- [97] W Wang and S Katipamula, "Part-Load Performance Characterization and Energy Savings Potential of the RTU Challenge Unit: Daikin Rebe."
- [98] "Partload Curves in EnergyPlus." [Online]. Available: <https://unmethours.com/question/17507/inputting-temperature-driftpoints-in-energyplus/>. [Accessed: 07-Mar-2018].
- [99] "Application Guide for EMS," 2017.
- [100] "External Interface(s) Application Guide," 2017.
- [101] "Building Controls Virtual Test Bed." [Online]. Available: <http://simulationresearch.lbl.gov/bcvtb/FrontPage>. [Accessed: 07-Mar-2018].
- [102] F. C. Winkelmann *et al.*, "DOE-2 supplement: Version 2.1E," Berkeley, CA (United States), Nov. 1993.
- [103] "DOE-2." [Online]. Available: <http://doe2.com/DOE2/index.html>. [Accessed: 07-Mar-2018].
- [104] "eQUEST." [Online]. Available: <http://www.doe2.com/equest/>. [Accessed: 08-Mar-2018].
- [105] "TRNSYS : Transient System Simulation Tool." [Online]. Available: <http://www.trnsys.com/>. [Accessed: 08-Mar-2018].
- [106] "Building Performance - Simulation Software | IDA ICE | EQUA." [Online]. Available: <https://www.equa.se/en/>. [Accessed: 08-Mar-2018].
- [107] "PowerFactory - DigSILENT." [Online]. Available: <https://www.digsilent.de/en/powerfactory.html>. [Accessed: 08-Mar-2018].
- [108] "GridLAB-D Simulation Software." [Online]. Available: <http://www.gridlabd.org/>. [Accessed: 01-Oct-2015].
- [109] D. Chassin, J. Fuller, and N. Djilali, "GridLAB-D: An agent-based simulation framework for smart grids," *J. Appl. Math.*, vol. 2014, pp. 1–12, 2014.

- [110] S. Katipamula, D. Chassin, D. Hatley, R. G. Pratt, and D. J. Hammerstrom, "Transactive Controls: Market-Based GridWise™ Controls for Building Systems," Pacific Northwest National Laboratory, Richland, WA, 2006.
- [111] H. Hao, C. D. Corbin, K. Kalsi, and R. G. Pratt, "Transactive Control of Commercial Buildings for Demand Response," *IEEE Trans. Power Syst.*, pp. 1–1, 2016.
- [112] "GridLAB-D Interfacing with External Software - GridLAB-D Wiki." [Online]. Available: http://gridlab-d.shoutwiki.com/wiki/Chapter_9_-_Interfacing_with_External_Software. [Accessed: 08-Mar-2018].
- [113] S. Karnouskos and T. N. De Holanda, "Simulation of a smart grid city with software agents," *EMS 2009 - UKSim 3rd Eur. Model. Symp. Comput. Model. Simul.*, pp. 424–429, 2009.
- [114] N. Gudi, L. Wang, V. Devabhaktuni, and S. S. R. Depuru, "Demand response simulation implementing heuristic optimization for home energy management," in *North American Power Symposium 2010*, 2010, pp. 1–6.
- [115] P. Faria, Z. A. Vale, and J. Ferreira, "Demsi — A demand response simulator in the context of intensive use of distributed generation," in *2010 IEEE International Conference on Systems, Man and Cybernetics*, 2010, pp. 2025–2032.
- [116] Y. K. S. Lee, "A Consumer Level Simulation Model For Demand Response Analysis On Smart Grid," *Digit. Sch. Univ. Nevada*, no. April 2012, p. 5, 2012.
- [117] T. K. Wijaya *et al.*, "DRSim: A cyber physical simulator for Demand Response systems," in *2013 IEEE International Conference on Smart Grid Communications (SmartGridComm)*, 2013, pp. 217–222.
- [118] K. Dittawit and F. A. Agesen, "Demand side focused simulation platform for the evaluation of demand side management approaches," *IEEE PES Innov. Smart Grid Technol. Conf. Eur.*, vol. 2015–Janua, no. January, pp. 1–6, 2015.
- [119] H. A. Aalami, M. P. Moghaddam, and G. R. Yousefi, "Demand response modeling considering Interruptible/Curtailable loads and capacity market programs," *Appl. Energy*, vol. 87, no. 1, pp. 243–250, 2010.
- [120] A. Pahwa and C. Brice, "Modeling and System Identification of Residential Air Conditioning Load," *IEEE Trans. Power Appar. Syst.*, vol. PAS-104, no. 6, pp. 1418–1425, Jun. 1985.
- [121] NYISO, *Special Case Resources: Evaluation of the Performance and Contribution to Resource Adequacy*. 2012.
- [122] NYSEG, "Distribution Load Relief Program." [Online]. Available: <https://www.nyseg.com/YourBusiness/demandresponse/distributionloadrelief.html>. [Accessed: 11-Jan-2018].
- [123] R. Sonderegger, "Dynamic models of house heating based on equivalent thermal parameters," 1978.
- [124] Z. Taylor, K. Gowri, and S. Katipamula, "GridLAB-D technical support document: Residential end-use module version 1.0," Oak Ridge, 2008.
- [125] "Residential module user's guide - GridLAB-D Wiki." [Online]. Available: http://gridlab-d.shoutwiki.com/wiki/Residential_module_user%27s_guide. [Accessed: 26-Jun-2017].
- [126] D. P. Chassin, J. Stoustrup, P. Agathoklis, and N. Djilali, "A new thermostat for real-time price demand response: Cost, comfort and energy impacts of discrete-time control without deadband," *Appl. Energy*, vol. 155, pp. 816–825, 2015.
- [127] N. Lu and D. P. Chassin, "A State-Queueing Model of Thermostatically Controlled Appliances," *IEEE Trans. Power Syst.*, vol. 19, no. 3, pp. 1666–1673, Aug. 2004.
- [128] *Regulation Training*. 2017.
- [129] "PJM Manual 12: Balancing Operations," 2017. [Online]. Available: <http://www.pjm.com/~media/documents/manuals/m12.ashx>. [Accessed: 22-Feb-2018].
- [130] R. Adhikari, M. Pipattanasomporn, and S. Rahman, "An algorithm for optimal management of aggregated HVAC power demand using smart thermostats," *Appli*, pp. 1–12.
- [131] M. Cai, M. Pipattanasomporn, and S. Rahman, "Day-ahead building-level load forecasts using deep learning vs. traditional time-series techniques," *Appl. Energy*, vol. 236, pp. 1078–1088, Feb. 2019.
- [132] "GridLAB-D House_e model source code." [Online]. Available: http://www.gridlabd.org/documents/doxygen/latest_dev/house__e_8cpp-source.html. [Accessed: 27-Jun-2017].
- [133] "DOMESTIC HOT WATER SYSTEM MODELING FOR THE DESIGN OF ENERGY EFFICIENT SYSTEMS," Upper Marlboro, MD, 2002.
- [134] M. Pipattanasomporn, M. Kuzlu, S. Rahman, and Y. Teklu, "Load Profiles of Selected Major Household Appliances and Their Demand Response Opportunities," *IEEE Trans. Smart Grid*, vol. 5, no. 2, pp. 742–750, Mar. 2014.
- [135] G. Fishman, *Principles of discrete event simulation*. 1978.
- [136] N. Matloff, "Introduction to discrete-event simulation and the simpy language," *Davis, CA. Dept Comput. Sci. Univ. Calif. Davis. Retrieved August*, vol. 2, p. 2009, 2008.
- [137] B. Larson *et al.*, "Residential building stock assessment: Metering study," Northwest Energy Efficiency Alliance, 2014.
- [138] A. Meurer *et al.*, "SymPy: symbolic computing in Python," *PeerJ Comput. Sci.*, vol. 3, Jan. 2017.
- [139] ANSI/ASHRAE 55-2010, "Thermal Environmental Conditions for Human Occupancy, ANSI/ASHRAE Standard 55," vol. 2010, p. 42, 2010.
- [140] M. Pinedo, *Scheduling: theory, algorithms, and systems*, 3rd ed. 2016.
- [141] Tim Roughgarden, A. Sharp, and T. Wexler, "120 Guide to Greedy Algorithms | Mathematical Optimization | Algorithms." [Online]. Available: <https://www.scribd.com/document/295073643/120-Guide-to-Greedy-Algorithms>. [Accessed: 23-Jun-2017].