

Along the River's Edge
A Bed and Breakfast Residence



Along the River's Edge

A Bed and Breakfast Residence

by Jennifer Ann Organsky

This thesis is submitted to the Graduate Faculty of
Virginia Polytechnic Institute and State
University in partial fulfillment for the degree of

Master of Architecture

Approved by:

William W. Brown - Thesis Chairman

Michael J. O'Brien

Warren Kark

February 2001
Blacksburg, VA

Abstract

There are many forces at work in a design process. Each element of a design sketch reacts to ones before and after it. As an designer, one must be able to look at each as an individual and as part of the whole. In addition, the ideals and experience brought to a project works its magic as well. It is the tension and the balance between the elements and ideals that create architecture.

With a Bed and Breakfast as a project vehicle, the connection to the site, the relationship between public and private areas, and how the materials and structure form spaces were studied. These considerations led to a process of discovery and the challenge to weave the site, structure, and materials in a cohesive design.

“Two roads diverged in a wood, and I--
I took the one less traveled by,
And that has made all the difference.”

Robert Frost



Table of Contents

Nature
Site
Order
Material
Structure
Light
Conclusion
Credits
Bibliography
Acknowledgments
Vita



Nature

“The idea of the country house immediately conjures up a whole series of images associated with proximity to nature and the desire to live in a landscape, to live life at a less hectic pace. In today’s society, centered on cities that impose their geometric landscape and their speed, the country implies a shift towards a different class of activity. Anyone who decides to build a house on a prairie or on the edge of a forest assumes an initial decision: the desire for a degree of isolation, the achievement of greater tranquility and the beginning of a two-fold journey: toward a heightened awareness of simple irreducible things. Mornings in the shade of the trees, afternoons by the river, the starry night sky, the sight of the horizon and the sun setting, and at the same time a gradual release from the webs of relationships and obligations which make up the urban fabric, and a move towards different facets of oneself, other personalities, which emerge as one’s rhythm of life slows down.”

F.A. Cerver in *Rustic and Country Houses*

Spending time in the countryside gives one a whole new sense of being. One comes in contact with nature first hand. The smell of the rain, the sound of a stream, the sight of deer, the power of nature is inescapable. When I was a child, I spent family vacations at my father's cabin. It was a modest hunting cabin set in the rural countryside of Potter County, Pennsylvania. Through the years, I have learned about the hard work and dedication it has taken to make the cabin that we enjoy today. I have gained an appreciation for nature, solitude, and simplicity of small structures. The founding fathers, as well as friends, helped build the 800 sq.ft. retreat over a 22 year period, with changes occurring throughout that time.



"I went to the woods because I wished to live deliberately, to front only the essential facts of life, and see if I could learn what it had to teach, and not, when I came to die, discover that I had not lived." (Thoreau 1996:118)





This time spent in the country helped to shape my thesis project. The decision was made to design a Bed and Breakfast. The purpose of the design was to create a place for family, friends, and guests to gather, relax, and enjoy the wonders of the countryside. A rural site in Bath County, Virginia was chosen encompassing a wide variety of site conditions. Mountains, valleys, streams, and rivers surround the location for the project. Important considerations for the design were: *the connection to the site, the relationship between public and private areas, and how the materials and structure form spaces.* A timber frame system and massive curved stone walls are the two major structural systems of the building. These considerations led to a process of discovery and the challenge to weave the site, structure, and materials in a cohesive design.

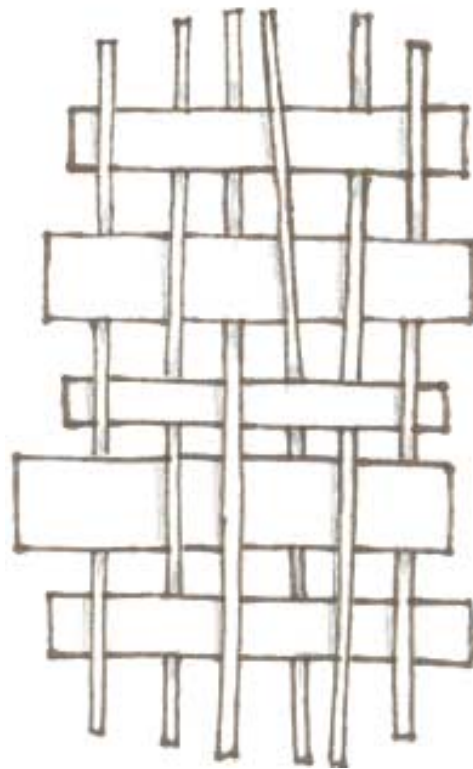

Give me the splendid silent sun...Give me an arbor...Give me nights perfectly quiet as on high plateaus...and I looking up at the stars...Give me solitude, give me Nature,give me again O Nature your primal sanities!

Walt Whitman *Give Me the Splendid Silent Sun*



Site

“The Site constitutes the land within its boundaries
And yet it extends beyond.

The Site is the hill, the valley, the rocks,
The very earth itself.

The Site is the climate, the sun, the rain, the wind
The lights and shadows which fall on it.

The Site is the sum of the very materials which constitute it:
Materialistic and etheric.

The Site is the tradition: the background, the past, the present
The whole totality of that particular place: visible and invisible

The Site is place

The Site is totality

The Site is environment.”

Richard England from *Voices of a Site*

Bath County is located in the West central portion of Virginia. In 1766, the first hotel on the present site of the Homestead Resort was built. Visitors began coming to Bath County and by the early 19th century, 6,000 visitors were arriving annually. In the 1800's and today, Bath County is recognized as a major outdoor recreation and resort destination. The "lush forests, rushing crystal rivers, hot and warm springs, and beautiful mountain scenery" are what draw thousands of visitors each year. Many of the visitors stay at The Homestead Resort, located in Hot Springs. This elegant hotel is regarded as one of the finest year round resorts in the world. Scattered throughout the small communities are additional hotels, rustic lodges, and bed and breakfasts for the use of the thousands of visitors.



"Although there are rugged peaks and deep ravines, it is essentially a peaceful, gentle land. the landscape has a feminine charm, with its high hills, buttressed by rounded shoulders, sweeping smoothly down to the valleys. It bespeaks of fertility and life, with its wooded hillsides overlooking green pastures."
(Ingalls 1949:1)

Five miles from the Homestead, a site was chosen for the project for this thesis, a bed and breakfast. One must travel from Hot Springs, over Warm Springs Mountain (2900 feet) and continue east descending into a valley. This scenic journey over the mountain, which descends some 1300 feet is breathtaking. Once over the mountain the land flattens in areas before once again erupting into a mountainous terrain. In the flattened areas along rural route 629, farmland clearings and forests change the density of the landscape. As one continues, two mountains appear in the distance. The site is located on the edge of this new change in elevation. The Cowpasture River flows at the foot of the mountains where a canopy of trees emerge on the riverbank and cover the mountain. Through the shade of trees one gets the first glimpse of the bed and breakfast.

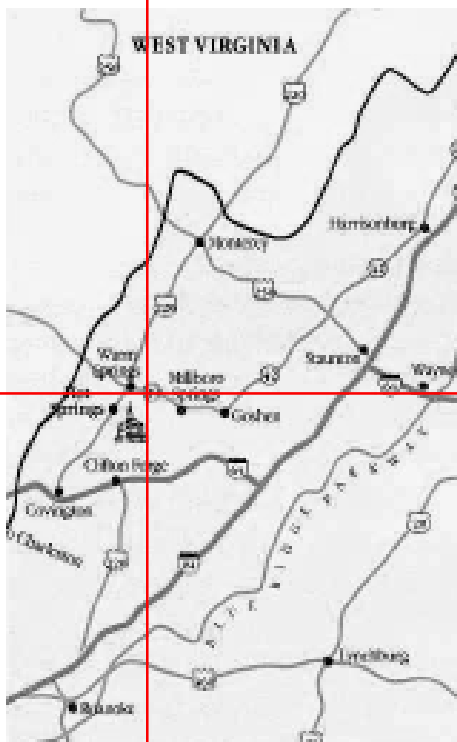
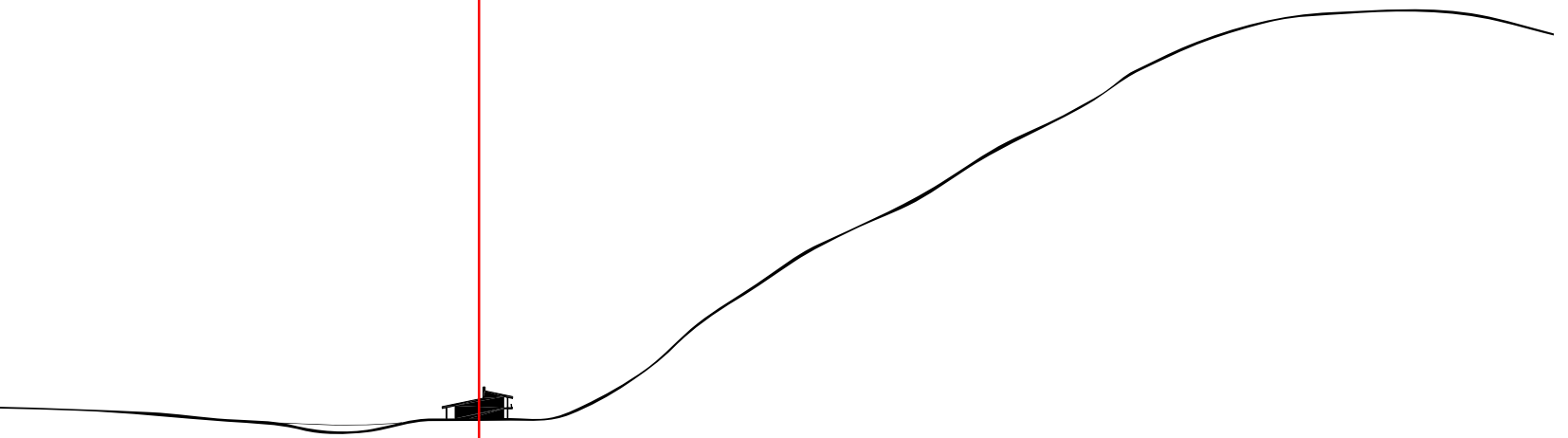
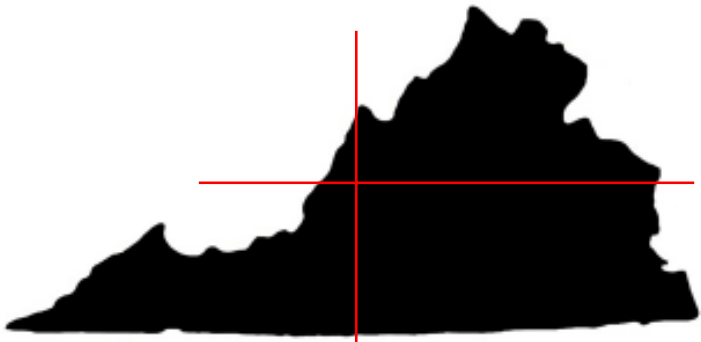

Traveling farther from the highway one becomes more in tune with their surroundings. Narrow roads lead past small towns twisting and turning to follow the contours of mountains. Dense forests shade the road, with rays of light breaking through bringing glimpses of the sun. Local shopkeepers wave good morning as one passes. Visitors are welcome to enjoy what the locals love about this area, the slower pace of life and the beauty of the countryside.



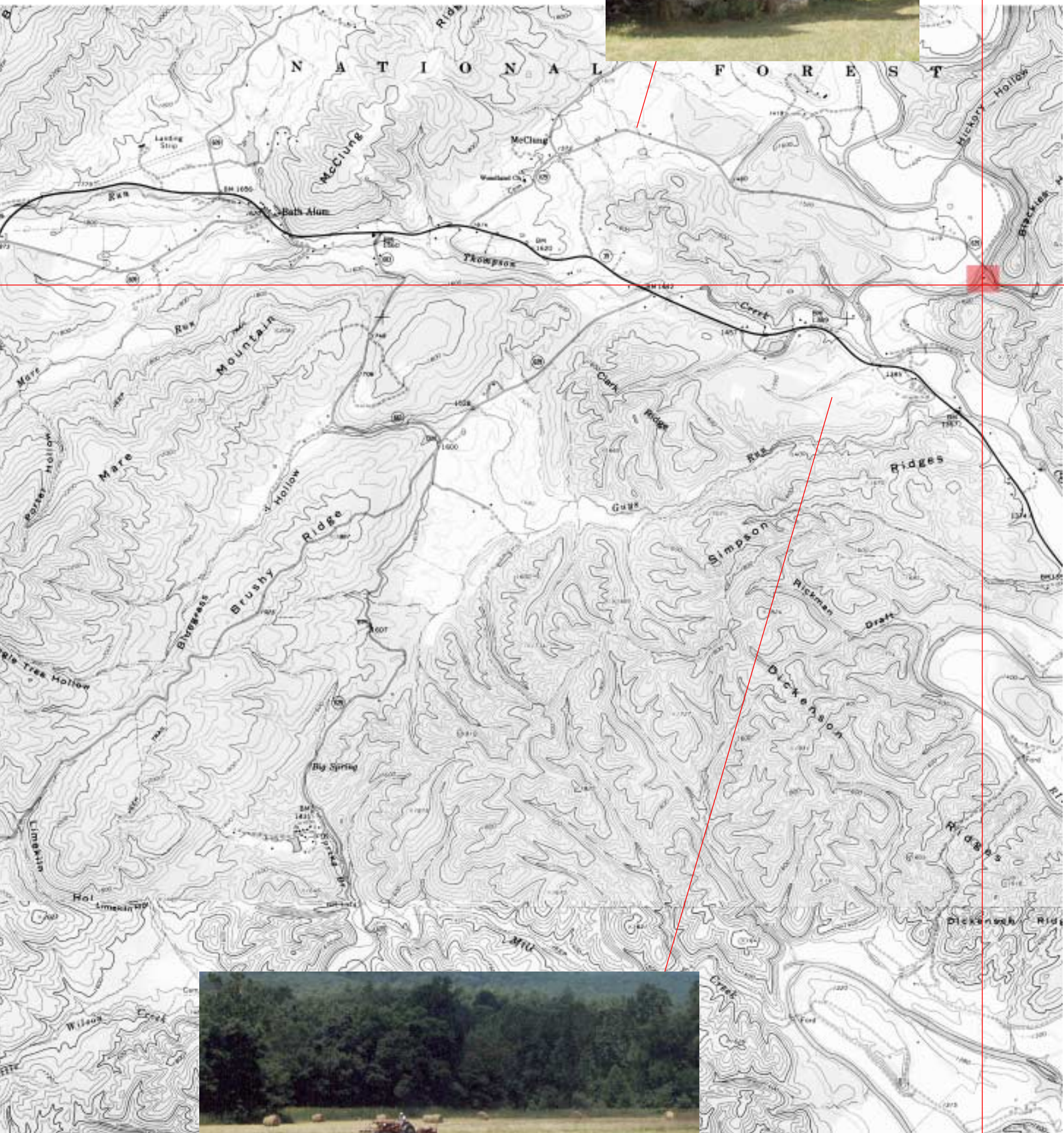

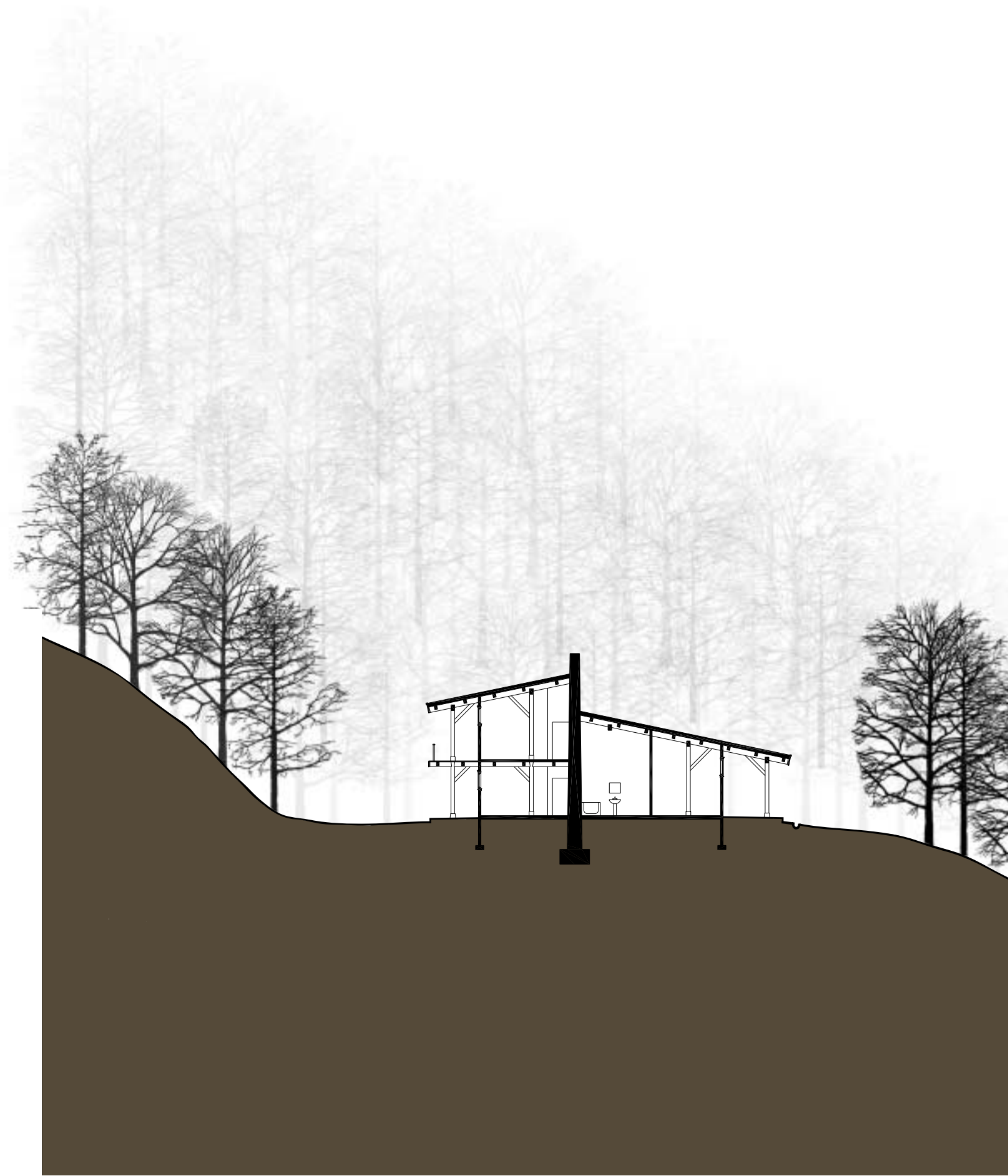

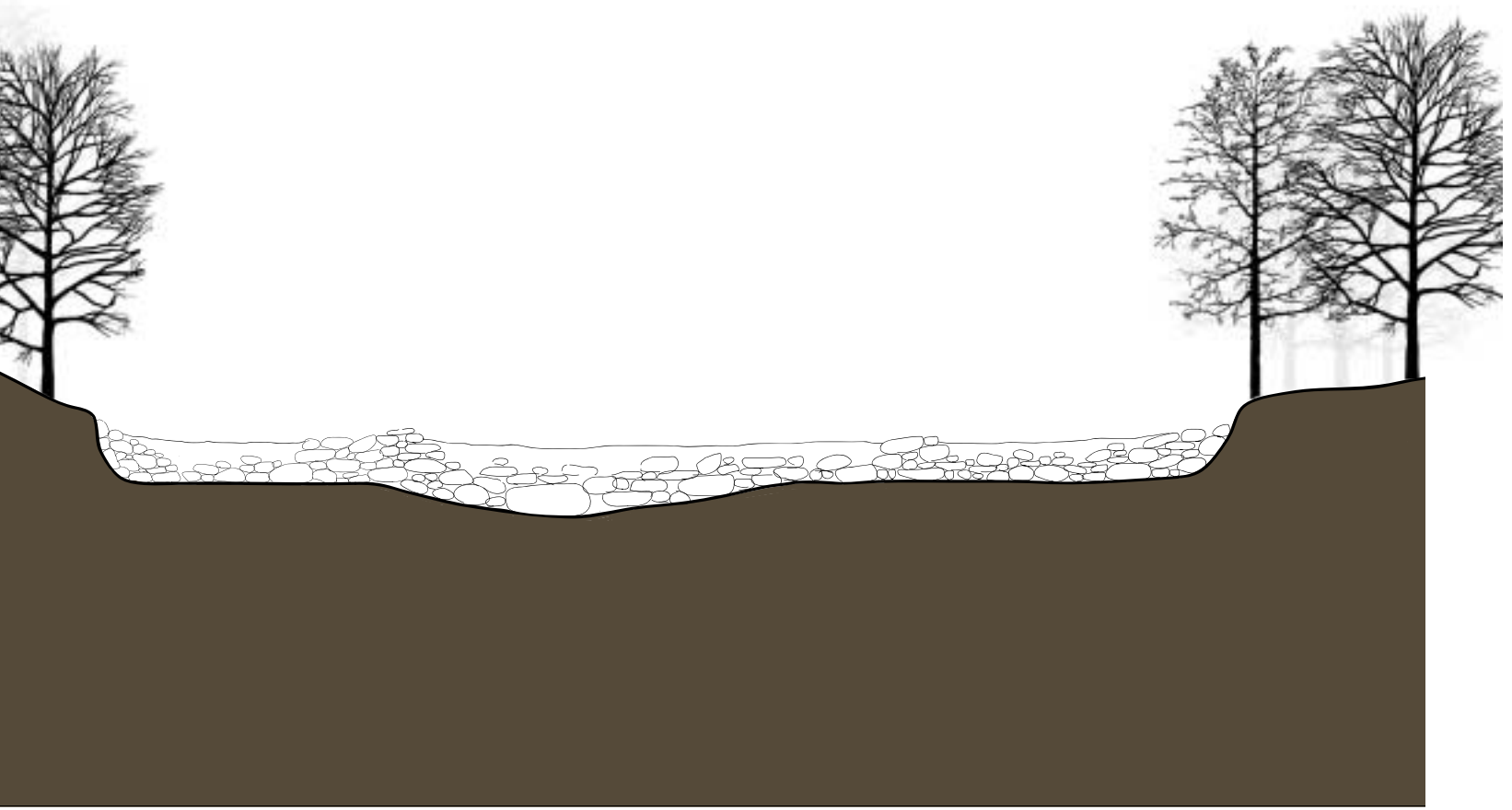

The overall idea about placement of the structure on the site developed from the topography. Early investigations placed a curved wall following the contour lines of the site and directed itself toward the river. A path was designed to start at the driveway entrance, continue to the parking area, cross a smaller bridge, and arrive at the front door.

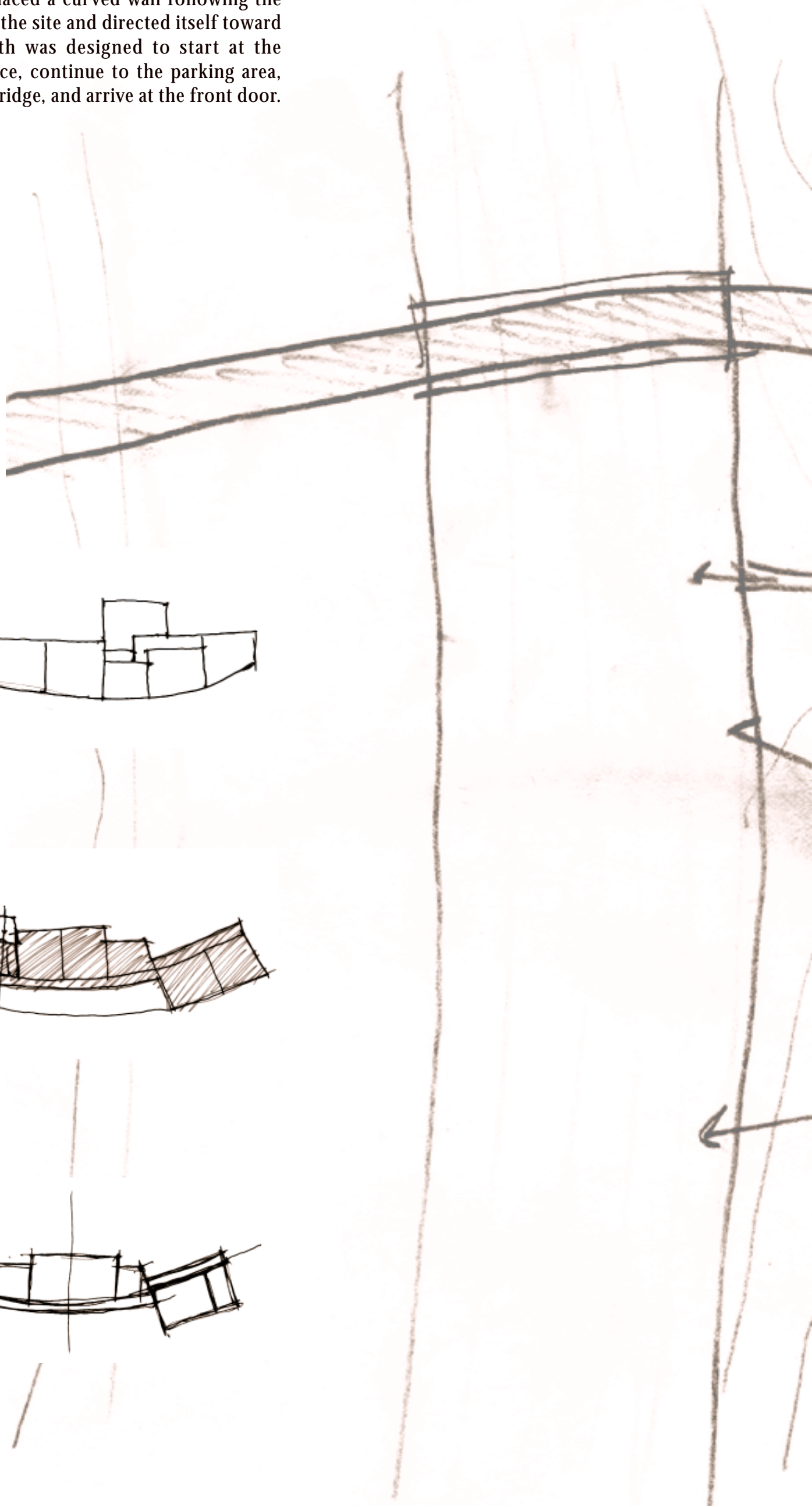
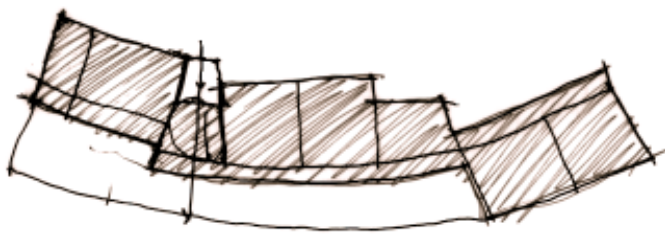



“One of the essential elements of good architecture is the route, the way in, the way through and the way out of a building.”
Tom Ellis “The Discipline of the Route”

“An architectural response to a site can begin with a symbolic gesture that is expressive of an attitude of the users toward the site.”
(Jensen 1990:92)

Crossing the river, one enters the realm of the site. Descending twenty feet into the canopy of trees, a closer view of the house is revealed. A stream that leads into the river lies between the visitor and the guest house. Together, the river, the canopy of trees and the stream are elements in the procession to the house, each one offering a different perspective and greater anticipation of inside. Once over the stream, the house is positioned far enough from each natural element so each remains untouched. This placement offers the best vantage point to view the mountain, stream, and river, creating a special place for a retreat. The placement of the house between the three natural elements allows one to reflect back on what brought them to this place in the woods; the desire to gain a new perspective of life, rest in the wonder of nature, and enjoy the slower pace of life.



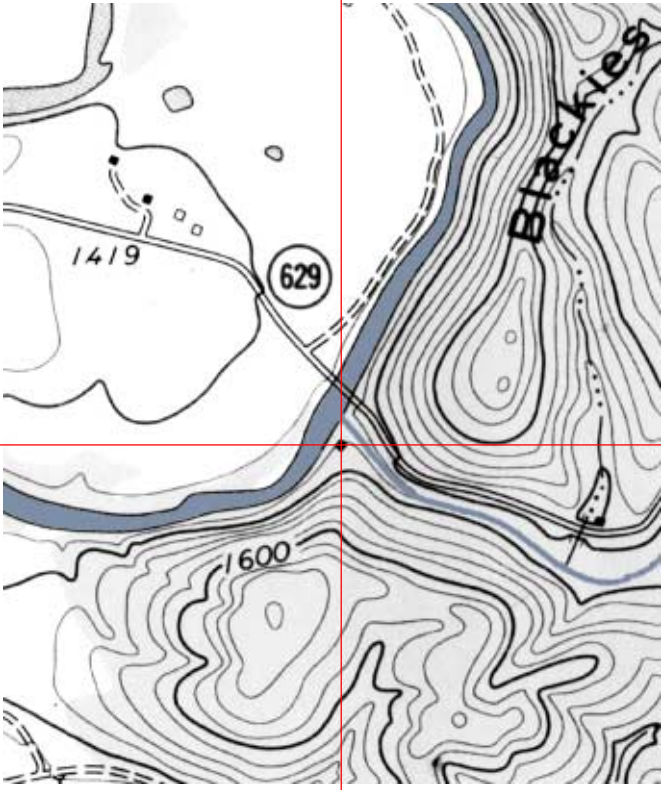



Cowpasture River

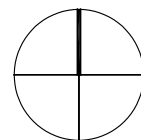

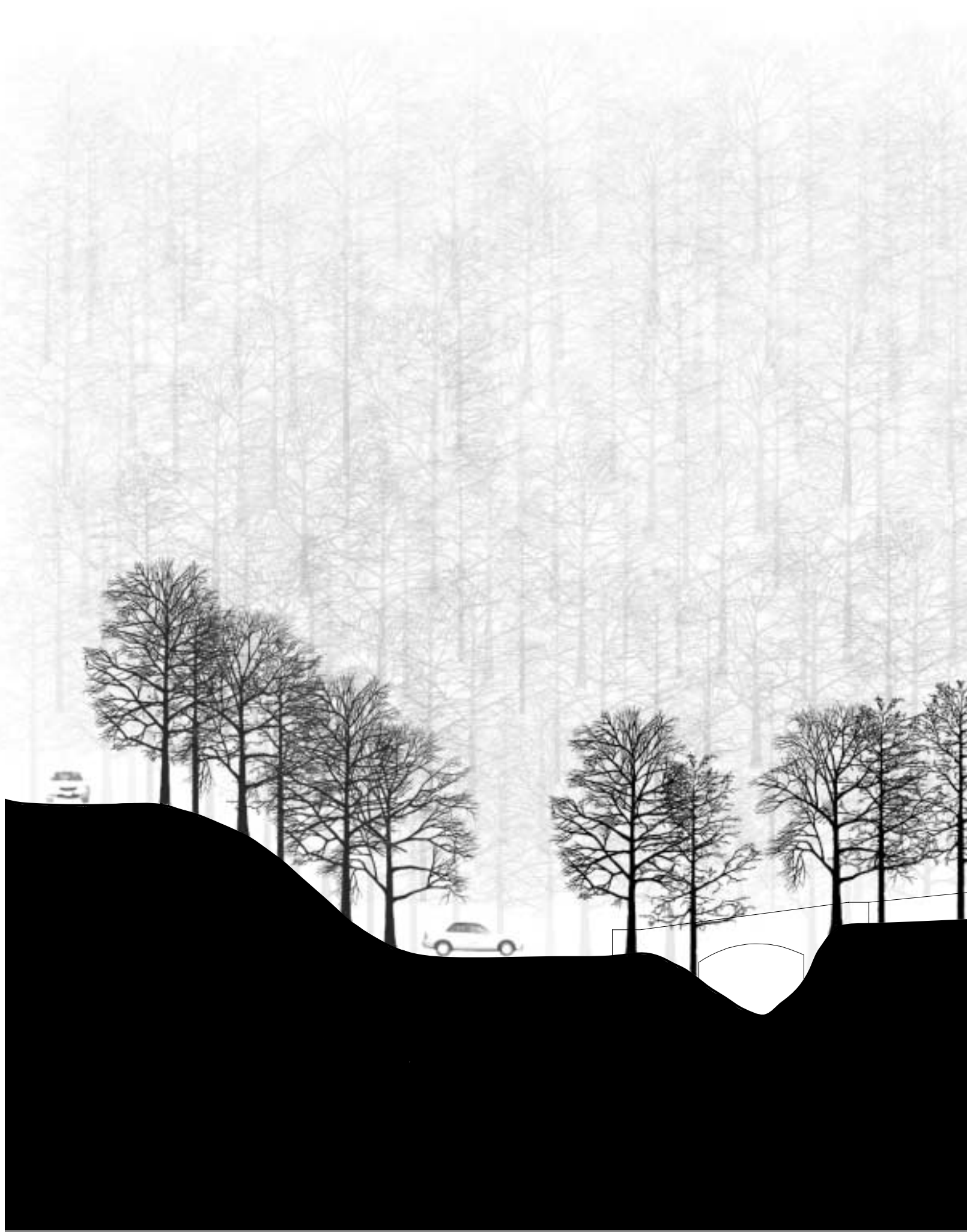

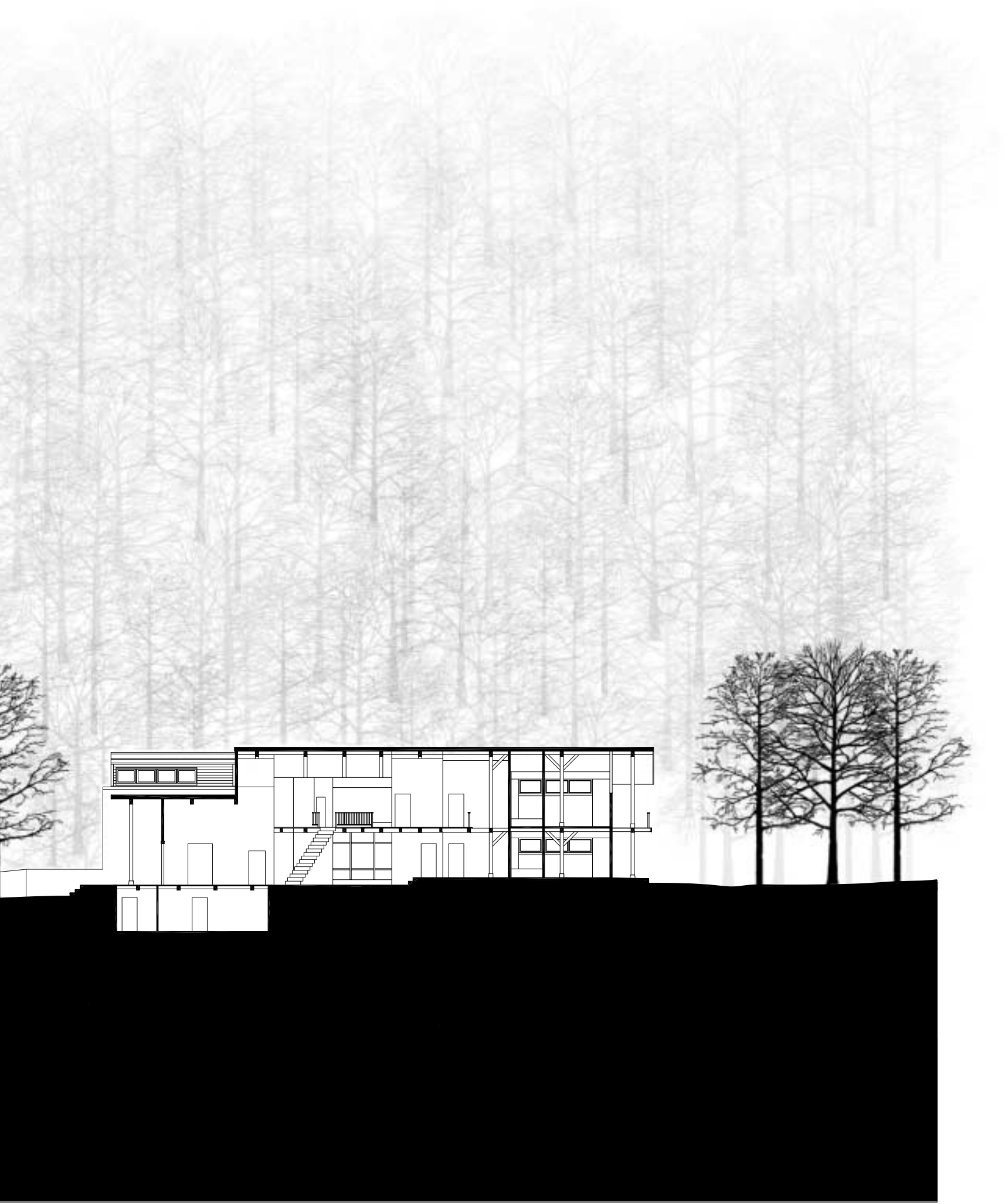

As I sat in the shade of a timber framed covered porch, the rocking chair creaked with every sway. I was taken away to another place. There were no sounds of traffic, no sounds of people chattering, no sounds of the hustle and bustle of everyday life I left behind. I found the sounds here to be soothing. The river rushed along, and the leaves were rustled by the wind's gentle hand. With birds chirping in song, I was able to look around and take in all that nature offered. Shadows of tree branches dancing in the wind, a deer with her fawn grazing in the field, and two butterflies twirling about. It is here in the countryside that we can slow down enough to see and hear these wonders of nature.





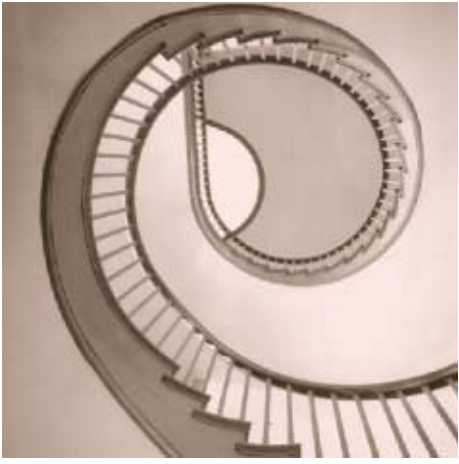

Order

“Design is necessary for the relative materialization of form. A balance between forces must be attained if unity is to be achieved within a field of perpetual change. When everything is released and emptiness is full, there is balance.

Form maintains its space in order to experience the time associated with it. Three dimensional form possesses both a mental and an aesthetic quality; both of which are characteristics of time.

Design is a dimensional vehicle. In form, design maintains a space, is finite and self limiting. In form, design becomes a vehicle traveling in time, yet design's capacities are infinite and its goals immeasurable.”

Carl Garant from Tao of Design

STONE WALLS

Stone walls are the primary element in the hierarchy of order. Studies of the entry sequence proposed that the wall starts in the landscape and continues inside to become part of the structure. At first there was one central wall that ran through the building. This wall curved and followed the contours of the site, as well as separating the public and private parts of the house. The wall was a static object, it did not change. Passing through rooms, it had the same thickness, and you only experienced one side of it. Qualities, such as the thickness, of the wall were not revealed.

The desire for a more complex wall led the way to break the wall into many pieces. The stone wall became rectilinear. The one wall was cut and shifted parallel to its original location. The trace of the movement was recorded by a stone floor. Where the pieces were displaced, a stone threshold recorded its original position. The repositioning of the pieces allowed the wall to change, as well as allow the viewer to experience the wall in more than one way. The wall now was a piece of a larger puzzle, each piece able to change in height, width, and function, to engage the spaces differently. The viewer now was able to walk around a wall, see it from all sides, and view its mass in section. This one act of breaking the wall into many pieces elevated its complexity and usefulness.

The development of the stone wall changed with the realization that connecting the building to the site was of utmost importance. The rectilinear scheme was analyzed for its orientation to the entrance path, the desire to direct views back to the outside, and its topographic position. A 30 degree shift was studied, splitting the building into two zones. This split was evaluated for its ability to address the above concerns as well as activate interior spaces. A direct link from the parking area to the front door and face to welcome guests was achieved. The views to the outside from the living space were redirected from a large concrete bridge located adjacent to the site, to the river and downstream. Guest rooms located in the south zone, had broad river views from the front rooms and partial river views from the rear rooms.

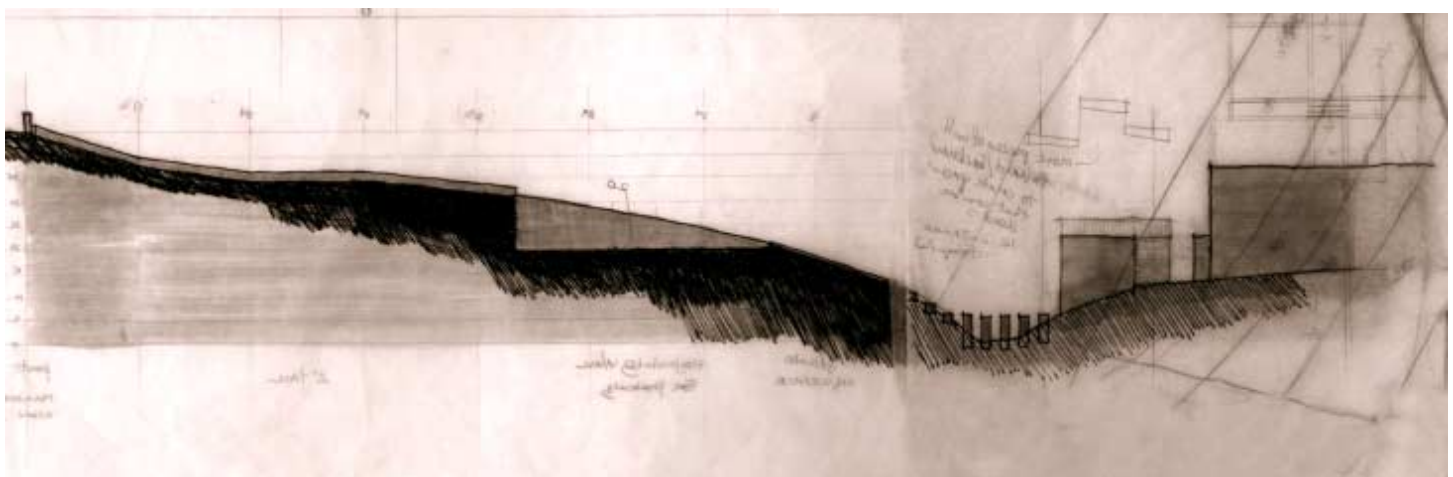
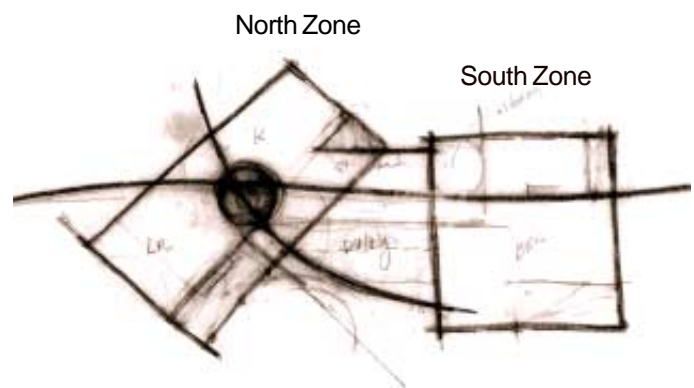
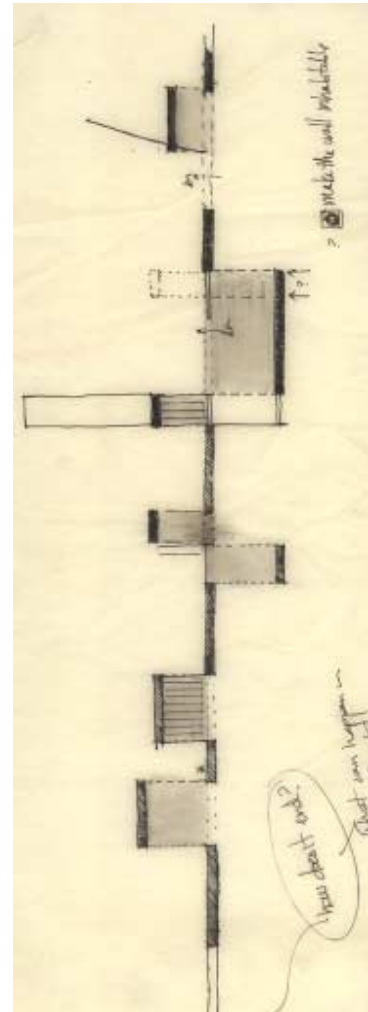
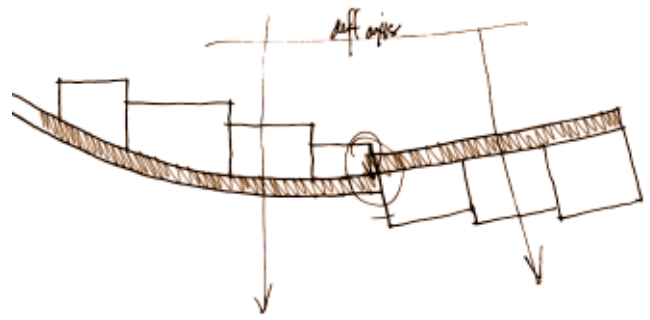



With functional concerns resolved, the relationship between the north and south zones with the stone wall needed to be addressed. As in earlier studies, the walls curve following the site topography, affirming the divide between the two zones. Following the curve made by the land, the stone wall leads the visitor into the house, and shifts inside to guide through the spaces to the guest rooms. The second wall of the two major walls becomes the actual connector to enclose the space between the north and south zones from the outside. It is a facade toward the river-view and continues into the living space and guest rooms. These curves soften the hard angles created by the 30 degree shift in the massing. This shift, along with the transformation of the stone walls, organizes the building spatially into living, guest rooms, and owner's zones.

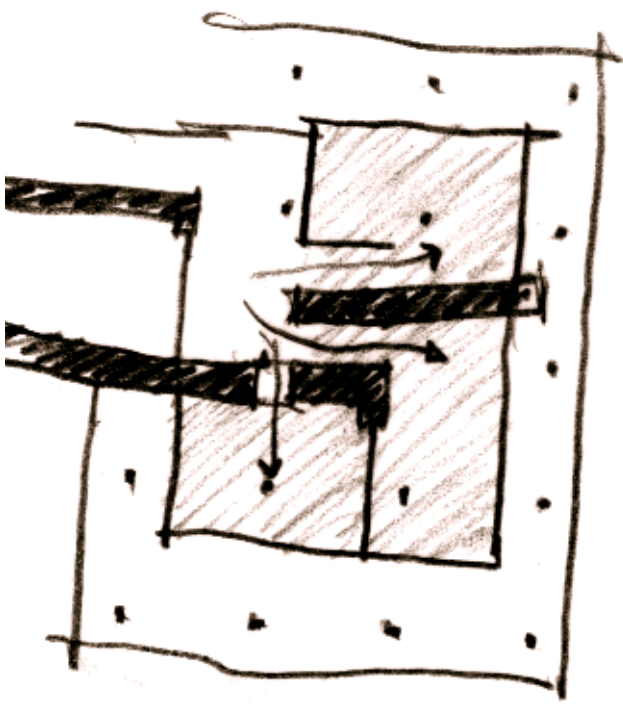

The stone walls that begin in the landscape and continue through the building activate the spaces by adding mass, texture and density. The walls direct attention toward entry spaces adjacent to them. By shifting the broken walls and allowing them to overlap in different planes, a space between the walls is made to emphasize passage from the sitting area to a river-facing room. This spatial compression is released when entering the room. The route to a forest-facing room leads you along the wall compressing you between a stone wall and a light framed wall, giving a release toward the lighter away from the sense of the mass and weight of the stones. A third route directs you through the wall to another river-facing room, engaging the guest with the stone mass reinforcing entry. The stone walls reinforce the act of entry into the guest rooms.



COLUMNS

Timber columns are the second element in the hierarchy of architectural order. The columns were introduced when the stonewall was in its final development. The 30 degree rotation of the plan had occurred and general placement of the stone walls were determined. In the first stages, sketches studied the minimum and maximum density of the grid. In the minimum study, the two rectangles of the split were 'outlined' to make a connection on the exterior with the site full of trees, and in the interior to reinforce the split. The result, was no interplay of the two elements. To address this concern, the maximum number of columns in the grid were studied. In places where the stone walls and the grid crossed, the stonewall replaced the column, however, in the area where the two grids met no rules were made. If the stone walls were to be used as a structural member, the amount of columns overrode this decision. (page 30 - sketches a,b)

A decision was made to utilize the stone walls more efficiently in the column order by sharing the responsibility of holding up the building. Reducing the number of column bays from four to three, changed the grid from 9'x9' to a 12'x14' grid. Another decision was made to remove the columns in-between the stone walls. These columns were redundant because the space between was short enough to span. The important decisions of changing grid spacing and removing columns helped to reduce the total amount of wood required and utilized both systems more efficiently by making one rely on the other to support the entire structure. (page 30 - sketch c)

Within the framework of stone walls and columns, light framed walls were used to enclose interior spaces. But where would the grid place the columns in relation to these walls? Would they be in the *plane* of the wall, just *inside* the wall, or just *outside* the wall? Many sketches showing different solutions resulted with no final decision. In frustration, columns were removed from the back side of the stone walls, leaving only two areas bound by the front wall in the column grid. Could this decision be justified? The areas left out of the grid were the private kitchen and living quarters for the owners and two guest rooms. Framing these areas in light wood construction was considered. Differentiating public and private areas was a possible answer, but this decision did not follow the rule. Having some guest rooms timber framed, some not, was investigated. How could these guest rooms be 'connected' to the private spaces but still be light wood construction? (page 30 - sketch d)

In the process of investigating the 'connection' questions the presence of wood in each space was investigated. Could elements of timber framing as well as light wood construction be used to build the same guest room? If so, what elements were required to make the decision cohesive? Timber rafters in the rooms were considered, for it would bring the texture, size, and presence of wood into these spaces. This decision seemed additive, it did not belong in the same language. Tying them into the light frame structure wasn't being true to the use of timber frame. I envisioned the timber frame structure as part of the entire order of guest activity. Perhaps the answer would come from another part of the project.

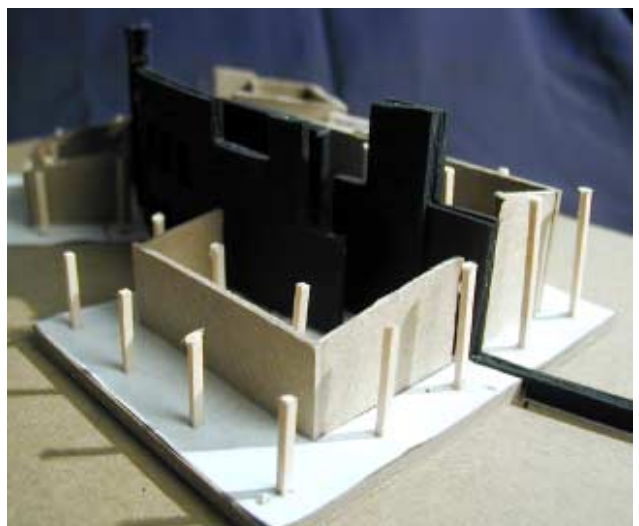

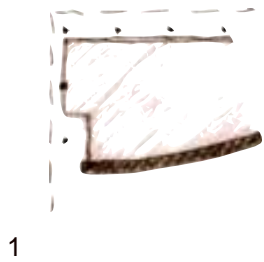

1



2



3

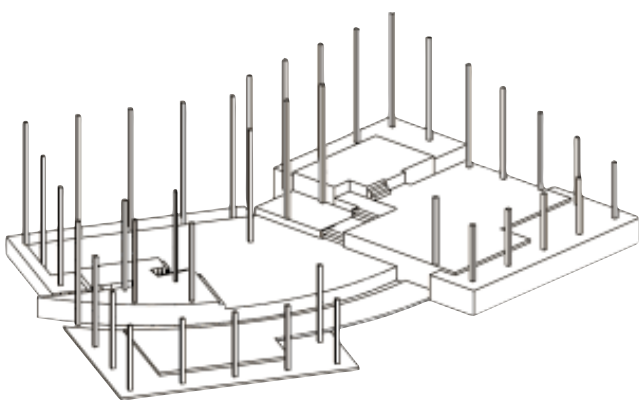
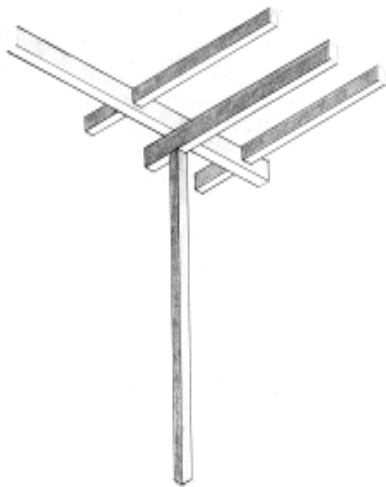

About this same time the roof enclosure was evolving. Three roof planes, living and kitchen, guest rooms, and the second floor, enclosed the spaces. The second floor roof helped to 'connect' the two split parts just as the stone walls did. The two front parts were 'connected' by way of the timber structure. One question still remained. How do the guest rooms (in the back section) 'connect' with the rest of the building intelligently? The solution was found by investigating how the roof and the stone walls came together. In section, the design of the three roofs and the stonewalls that supported them created a potential water runoff problem. The second floor roof, as well as the other two roofs, sloped toward the river. A barrier for the water was created between the two planes. The problem could be resolved with 'mechanical' devices, but perhaps a change in the architectural form would best overcome this obstacle.

With alterations in massing, issues regarding the use of timber frame *or* light wood construction became clear. Underlying ideas of function began to play a vital role. Intelligently connecting guest areas and private areas with construction methods was needed. Revisiting the question, how do the back guest rooms relate both to private and other public areas was crucial. Roof massing now connected the private owners quarters with the back guest rooms. How would the other guest rooms be connected? The solution was to continue the timber frame to join the four guest rooms on either side of the stone wall, and to have the stacked private owners space be light wood construction. From the exterior the form reinforced the function. This differentiation in form and function completed most of the puzzle, but one piece still remained.

With the stone walls and general guidelines of the grid in check, exact placement of the columns was left to be designed. Structurally, the stone walls and columns work together each carrying its share of the roof. Spacing from stone wall to column was such that spanning members did not have to be sized differently. With general spacing requirements understood about the structure, studies again turned to the position of the columns in relation to light framed walls which enclosed the interior spaces. Where would the grid place the columns in relation to these walls? Would they be in the *plane* of the wall, just *inside* the wall, or just *outside* the wall? (sketch 1,2,3) Through continual studies and the changes that occurred in organizing the ordering elements, the decision was clear. The final scheme positions the columns *free* of the walls. The columns stand apart far enough from the wall so as to be seen as a separate element. It was essential that one could walk around the column. A radius of three feet around each column was designed to be unobstructed. This gave the column its own presence in each room. This was also true of exterior spaces. As an extension of the house, sheltered places for sitting, which made a transition from inside to outside, were designed. The three foot rule sized the exterior spaces shaping places for sitting and walking. The final result of the three foot rule located one timber column in four of the five guest rooms. (The fifth room, located between the stonewalls utilizes the stone walls for support not timber columns.) The one timber column, with its beam, rafter, and purlins overhead to support the roof, provide a wonderful presence overhead in the small space. Together, the ordering of the stone wall and the timber column grid complement each space beautifully. (page 30 - sketch e)

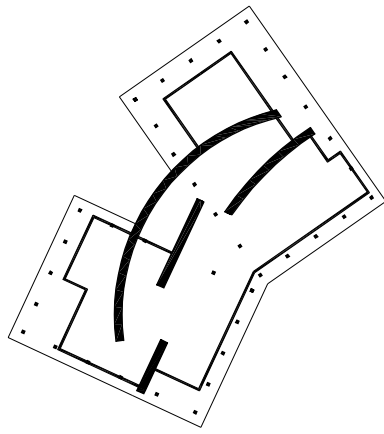

a

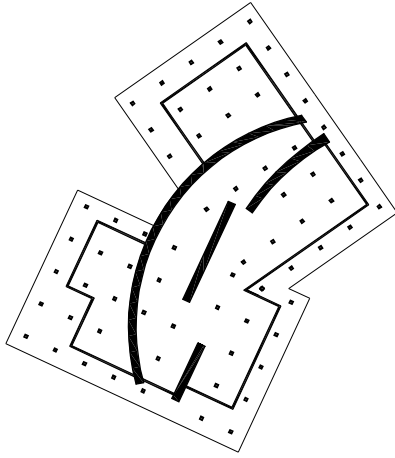

b

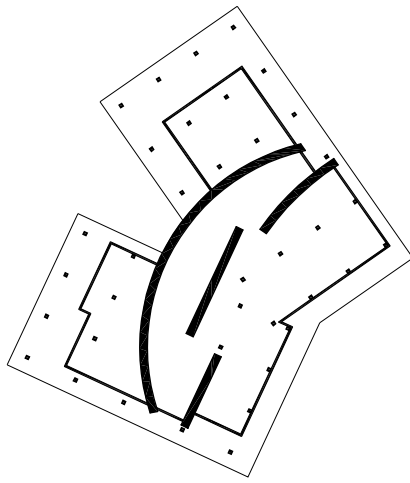

c

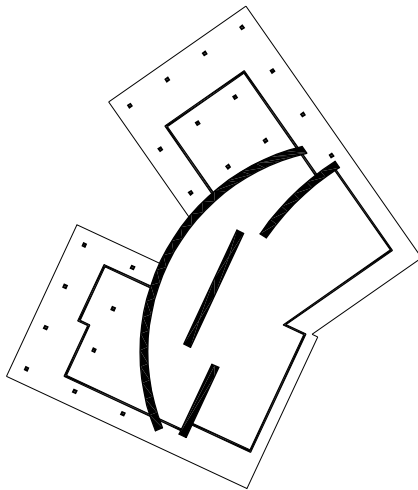

d

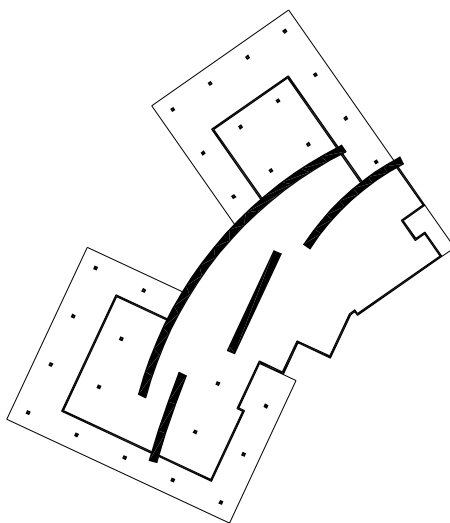

e

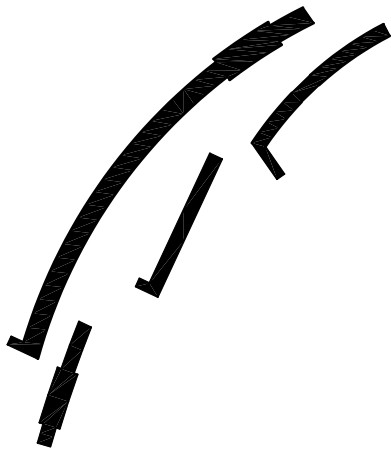

Stone Walls



Wood Columns

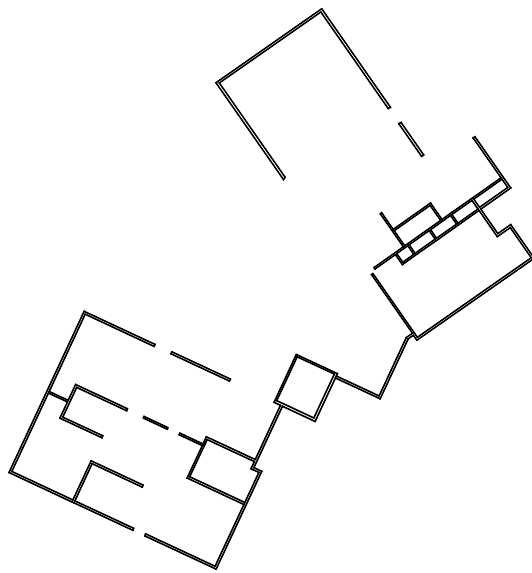

Light Frame Walls

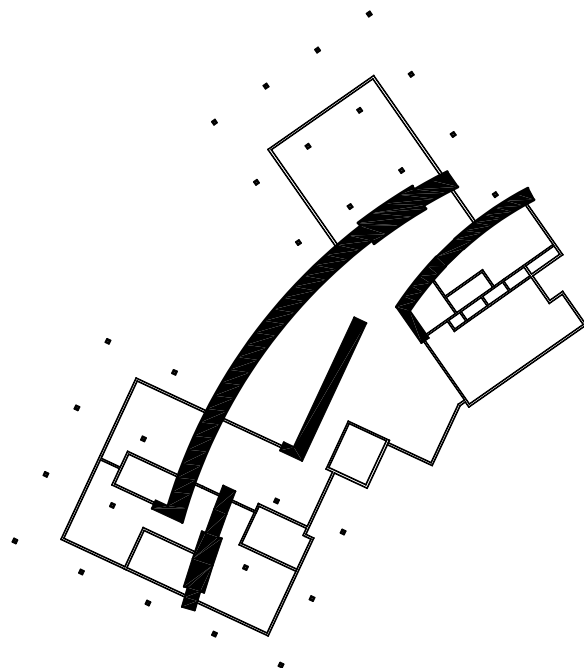

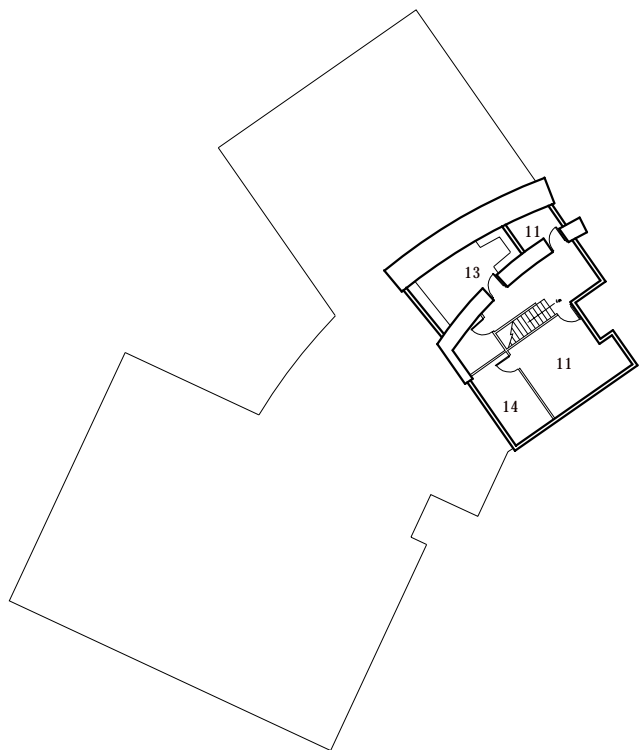
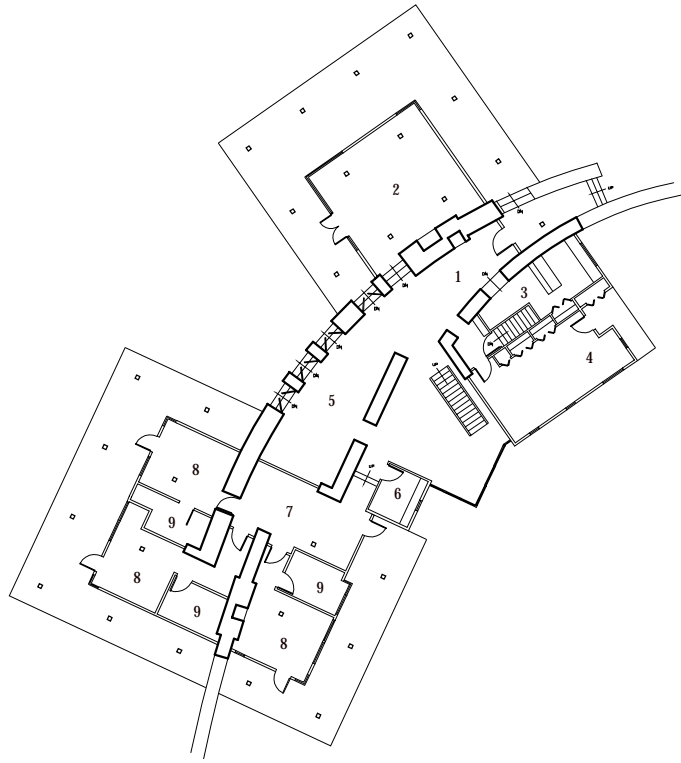
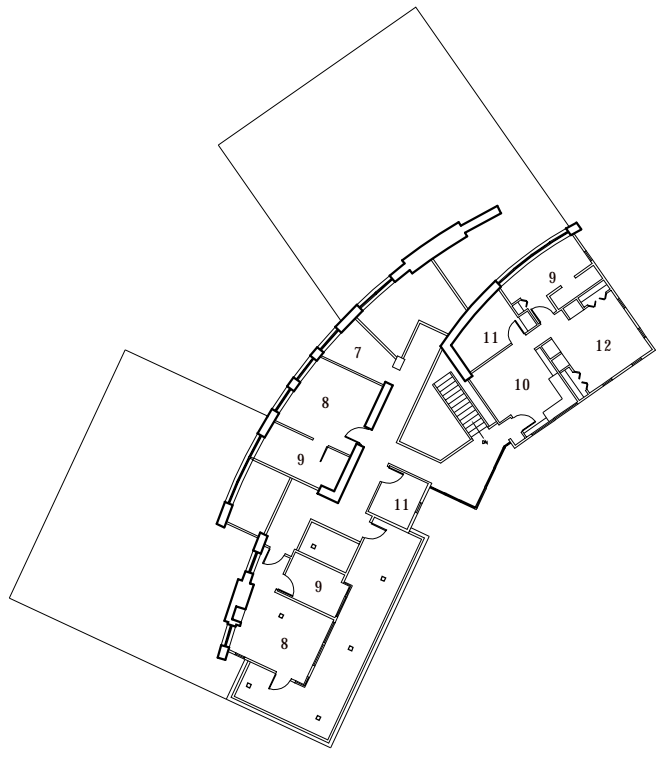

- 1-Entry
- 2-Living room
- 3-Office
- 4-Kitchen
- 5-Dining room
- 6-Laundry
- 7-Sitting area
- 8-Guest room
- 9-Bathroom
- 10-Sitting(owner)
- 11-Storage
- 12-Bedroom (owner)
- 13-Wine Cellar
- 14-Utility

1 5 10

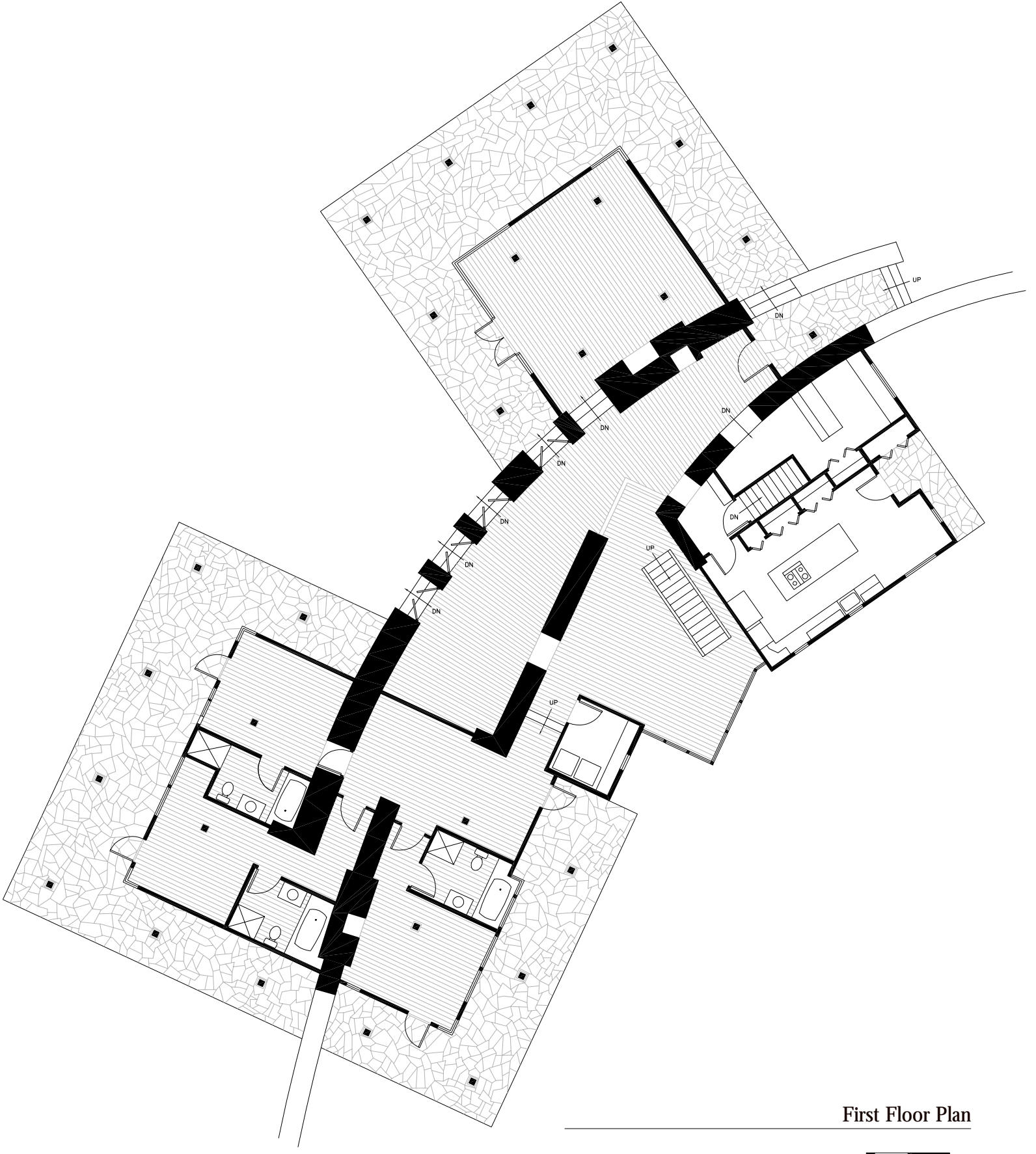

First Floor Plan

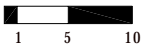



Second Floor Plan

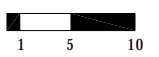

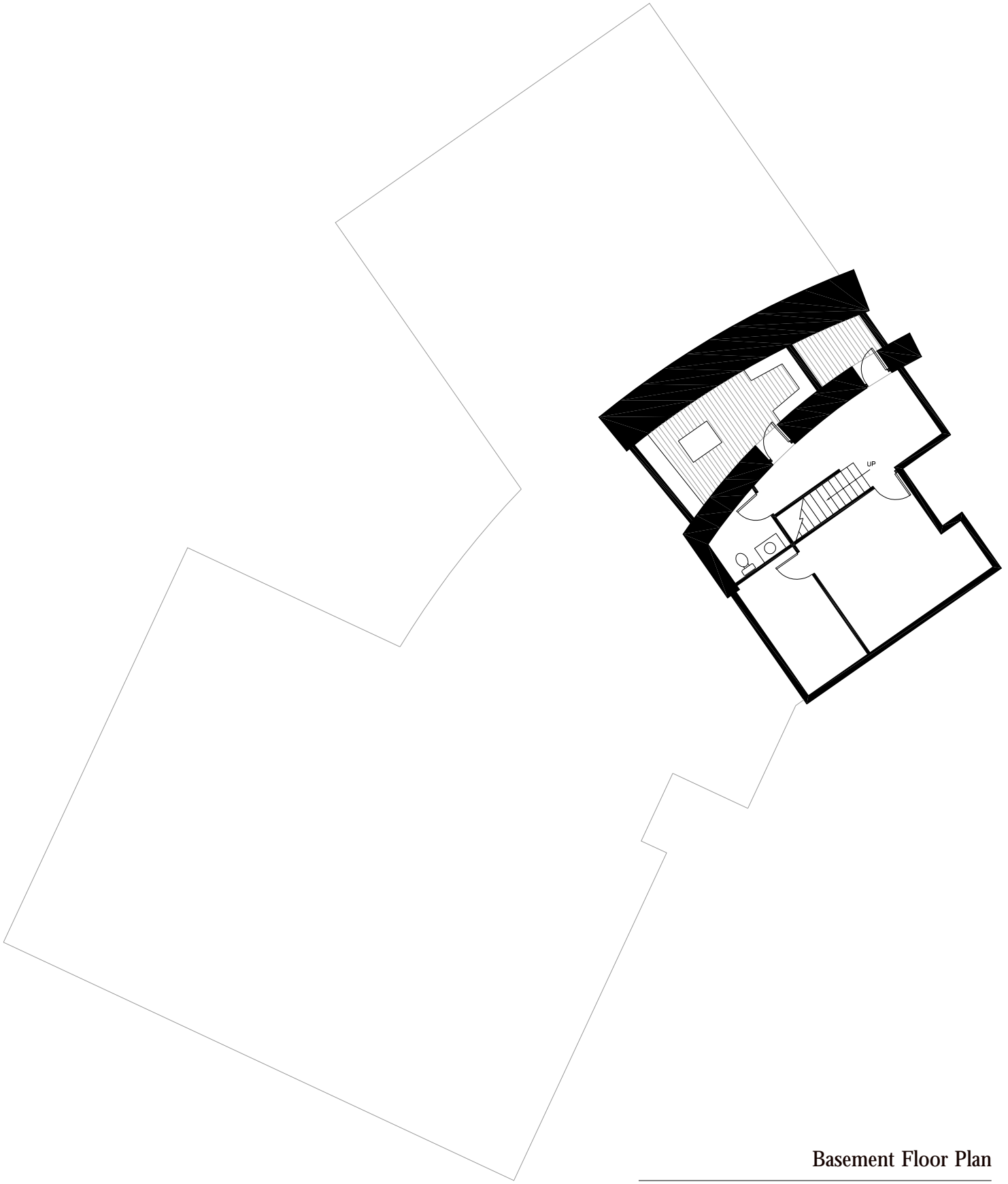

Basement Floor Plan





Material

Marco Polo describes a bridge stone by stone.

“But which is the stone that supports the bridge?”
Kublai Khan asks.

“the Bridge is not supported by one stone or another,”
Marco answers, “but by the line of the arch that they form.”

Kublai Khan remains silent, reflecting.

Then he adds: “Why do you speak to me of the stones?
It is only the arch that matters to me.”

Polo answers, “Without the stones there is no arch.”

Italo Calvino from *Invisible Cities*

STONE

I had an opportunity to see a stone wall under construction in the town of Ballymacward, located in county Galway, Ireland. Two men were rebuilding a tumbled down wall adjacent to an older one. Centuries old, it was getting a new face, using the same weathered stones. The wall was approximately 500 feet long and about 4 feet tall. Guiding you through the small town, the wall turned the corner and ended in front of the church. This wall was a landmark holding its place near the town center. The two men had been working on the wall every day for about four months and had many more hard days of working to go. In all, it is a labor of love to construct such a wall.

After seeing these men put forth the effort and craftsmanship required to construct such a beautiful wall, I began to see the stones differently. The countryside is filled with miles of stone walls used for retaining the land, fencing in pastures, lining driveways, and forming small bridges over streams. A strong and very durable material, it is with good reason some of these walls have been around for hundreds of years. Thinking back to those two men choosing the one stone that would fit nicely against the last, I realized that the same time and skill was required for these walls as well. Each stone presented a design challenge and might be handled three or four times before being chosen for placement in the wall. The cracks, indentations, convolutions, irregularities, and differences of light and dark add to the value of each stone. In a fieldstone, wall attention is given to these characteristics to distribute the random colors and sizes throughout the wall. The individual characteristics of each stone bring beauty to the whole composition making a masterpiece of the parts.



“Man has always treated stone more imaginatively. It began when Glog-the-caveman picked up a stone and heaved it at his neighbor. That is the problem with a single stone. I mean, what else can you do with one stone but throw it? A pile of stones is a far more constructive thing.” (Schwenke 1975:5)



In the Valley Verrzacsca, located in the Ticino region of Switzerland, an array of stone buildings from old to new capture a sense of material. Sognogno is a small town located in the valley where the buildings are constructed from the local indigenous stone. The stairs, the load bearing walls, up to the roof 'shingles', are all laid in stone. Modern construction methods have not changed dramatically. The use of timber is added for structural roof supports, and stones remain the material for the roof covering in lieu of wood or metal. Walking around the all stone village one is taken back to a world of building from long ago. One is made aware of the material and construction, and the grandeur of its presence.

For this thesis project, I chose to use a local weatherface building stone with colors ranging from grays to pinks for the structural walls and arches. The sills and tops of the walls are capped with a limestone, which refines parts of the stone massing. The exterior stone of the covered porches is an irregular bluestone flagstone, and its smooth texture nicely contrasts the rough building stone.



A section drawing through the guest area shows the connection where the timber frame meets the plane of the stone wall.

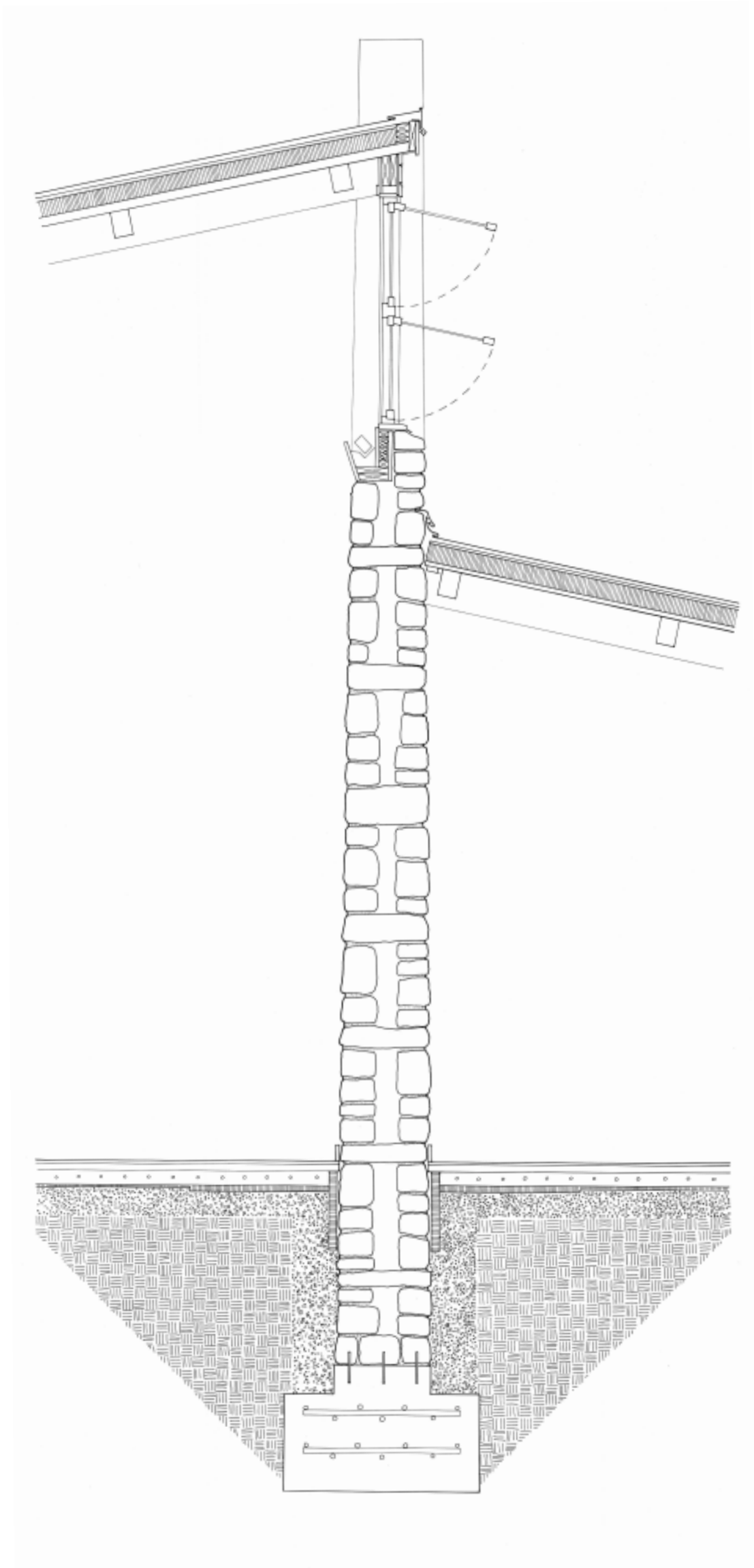

The repetition of wooden beams and rafters forming the timber frame structure are depicted in this section drawing of the guest area.

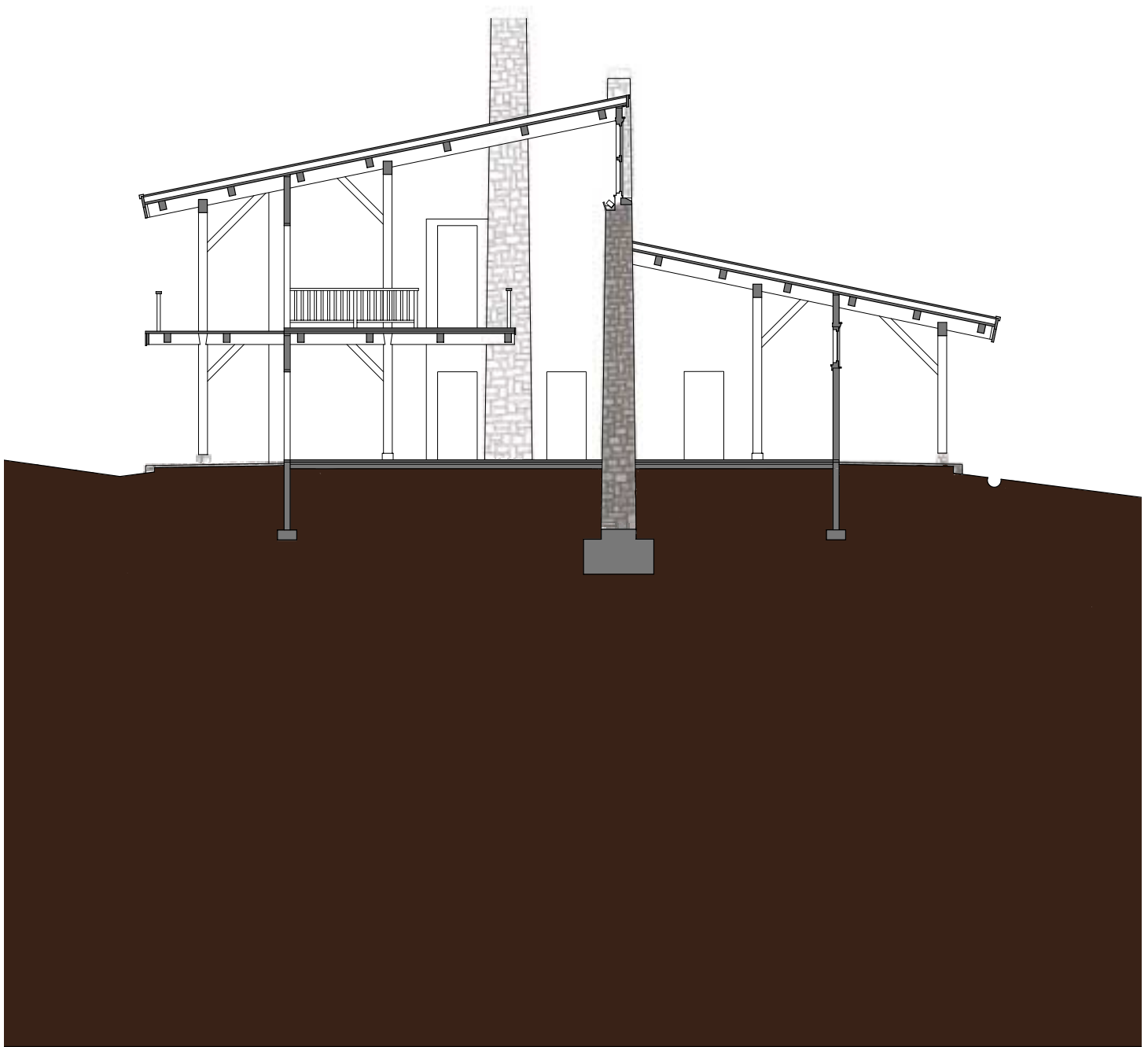

WOOD

“The sight of a barn can still inspire awe not only because of the power of its size and the beauty of its structure, but because of what it stands for as well; human perseverance, ingenuity, and craftsmanship.” (Larkin 1995:64) Viewed in the landscape, a barn has a recognizable form; however, once inside, the materials of the structure speak a different language. The massive timbers crisscross and soar up to the roof. The strength, age, mass, and presence of the wood capture one’s attention. Unlike a fieldstone wall where each stone is used based on its present form, each wooden member must be shaped to an exact form so all the pieces will fit together. I had the opportunity to visit Blueridge Timberwrights, a local timber frame company in Elliston, Virginia. I was able to see firsthand the labor and precision needed to make each timber connection. I watched the craftsmen planing, sanding and chiseling the wood to shape the pieces. The framework of refined pieces becomes a magical work of art.

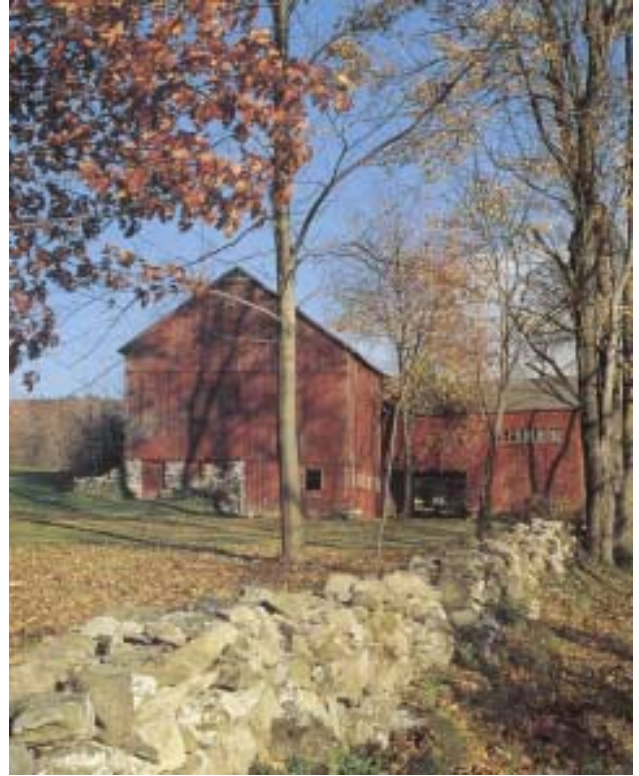



Over the centuries many craftsmen have manipulated wood into marvelous works. The shakers were one such people. Woodworking in the Shaker manner is simple and functional. This entails furniture, millwork, and interior moulding to cite a few examples which are committed to balance and order. Devoid of all forms of decoration and ornamentation, each piece is handmade to perfection. The beauty derives from its perfect functionalism. The pieces may appear to be plain, but if closely admired, there is care in the proportions. Dresser drawers decrease slightly in height as they rise. Each peg is threaded at the base to twist easily into or out of a pegboard. When the constraints and possibilities of a material are mastered, one can create refined objects that survive the test of time.



It is in the language of refinement that I envision the use of wood in my thesis project. Reclaimed douglas fir timbers are employed for the structural members. In keeping with environmental concerns, recycled timbers have the added benefit of bringing something from a past project to a newly built structure. The timbers will be newly planed achieving a refined quality but still show the marks of the past in previous joints. Cherry wood will be used for cabinets in the kitchen, bath, and for built-in furniture pieces. Oak will be used as a flooring material throughout the main living spaces and guest rooms, and as accents in cabinetry.



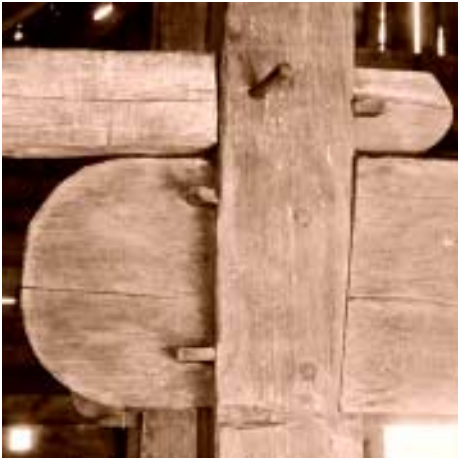

Structure

Look there!

 It stands today
As strong as six-score memoried years ago;
A big barn built to hold fat crops in its massive mows,
As provender to last the long rows of sleek cows,
In the stables underneath,
The long dark winter through.

 Examine, if you will,
These giant plates and beams,
These stalwart loins and limbs and thighs.
Each one was once upon a splendid time
A giant pine
Singing a hundred feet towards the skies,
Then topped to sixty feet of needed length,
Hewed from the round to fourteen inches square.

 See There!

The marks of hewing axe and adze,
Swung straight and true.

 Read there the tale
Of toil and seat and fine pride
In shaping these great timbers.

 Stand with me
A wondrous moment.

 In that crafted tree
Is history enough of old great-grandsire times
A centry ago and more.

 Those sheathing boards,
Those tenons, mortices and dowells,
Those thews and sinews,
Those mitres bevelled true,
Fitted in tight embrace to fight the winds
And the strong side-thrust of the sheaves and hay.
There stands my barn!

 Monument to the past!
 Feast for the present!
 Song for the future!

My Barn by Dean Hughes

Load Bearing Stone Wall

The first stone shelters were caves; houses by subtraction. Before long, caveman realized the reverse could apply, and used the addition process to construct a wall. By placing flat rocks one on top of another, he could 'design' the dwelling to his liking. Except for the addition of mortar, this process has not changed remarkably to the present day. (Schwende 1975:17) In this thesis project the walls are constructed in the same traditional manner with the joints struck fairly deep so that the mortar is in shadow. Being the primary structural element they are the first element to be built. The large footings must accommodate walls from 4 feet to 45 feet tall for the chimneys. Being fairly tall, the walls gain more stability due to the curve shape. When the stones are laid, two walls will actually be built with tie-stones across both to connect them together. As the walls are built, arched openings, fireplaces, and places to receive the timber structure are built.

Timber Frame

Due to the 30 degree shift in the rectilinear masses, two timber framed structures are tied into the stone walls. There are two stages in assembling the frame. Bents are assembled to stand parallel to the stone walls. Each bent is constructed of columns, beams, and bracing. The columns, spaced every 12 feet, are connected to beams by mortise-and-tenon joinery with a peg for extra support. Bracing between the two members helps stabilize and prevent racking. The columns are then tied into pier foundations with exterior columns sitting on stone bases protecting the end grain from water. After these bents are put in place and temporarily braced, one rafter at a time connects each bent and ties the timber frame structure to the stone wall. As each rafter is put into place, purlins are connected in between to support the roof decking. Additional bracing prevents lateral racking perpendicular to the walls. As the bents are assembled in the forest-facing guest rooms, floor joists and bracing are connected into each column. Each column, beam, rafter, knee brace, joist and purlin must be crafted with uncompromising workmanship for the structure to be sound.

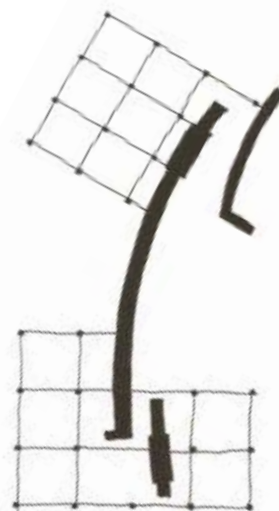

"A stones' innate beauty should figure in any house building effort, but its functional nature as a supporting and enduring component in a wall are of primary importance." (Schwenke 1975:18)

Exposed Members

A modern day light frame building hides all structural members typically inside the wall itself. Walls are covered with gypsum board or plaster with structural walls looking no different from the others. The homogeneity of these blank walls supporting the roof and floors say nothing of the structural nature of these elements. In contrast, the bearing conditions of a timber frame are completely revealed. The strength, stability, and craftsmanship are exposed. The details of joinery adorn the space, and the dance of columns and beams hardly goes unnoticed. The dovetails, mortise-and-tenon, and beveled shoulder connections “are practically the definition of the product. Without the joinery there is a structure made with posts and beams, but it is not a timber frame.” (Benson 1997:41). By exposing the wood in a very special and unique way this allows one to celebrate the construction of wood. This honesty in construction is the value in a timber frame structure.



An isometric drawing of the living room shows all the pieces of the timberframe structure. A segment of the stone wall is shown that holds the fireplace for this two storey space. The following pages show details of the connections and layers of the framework.

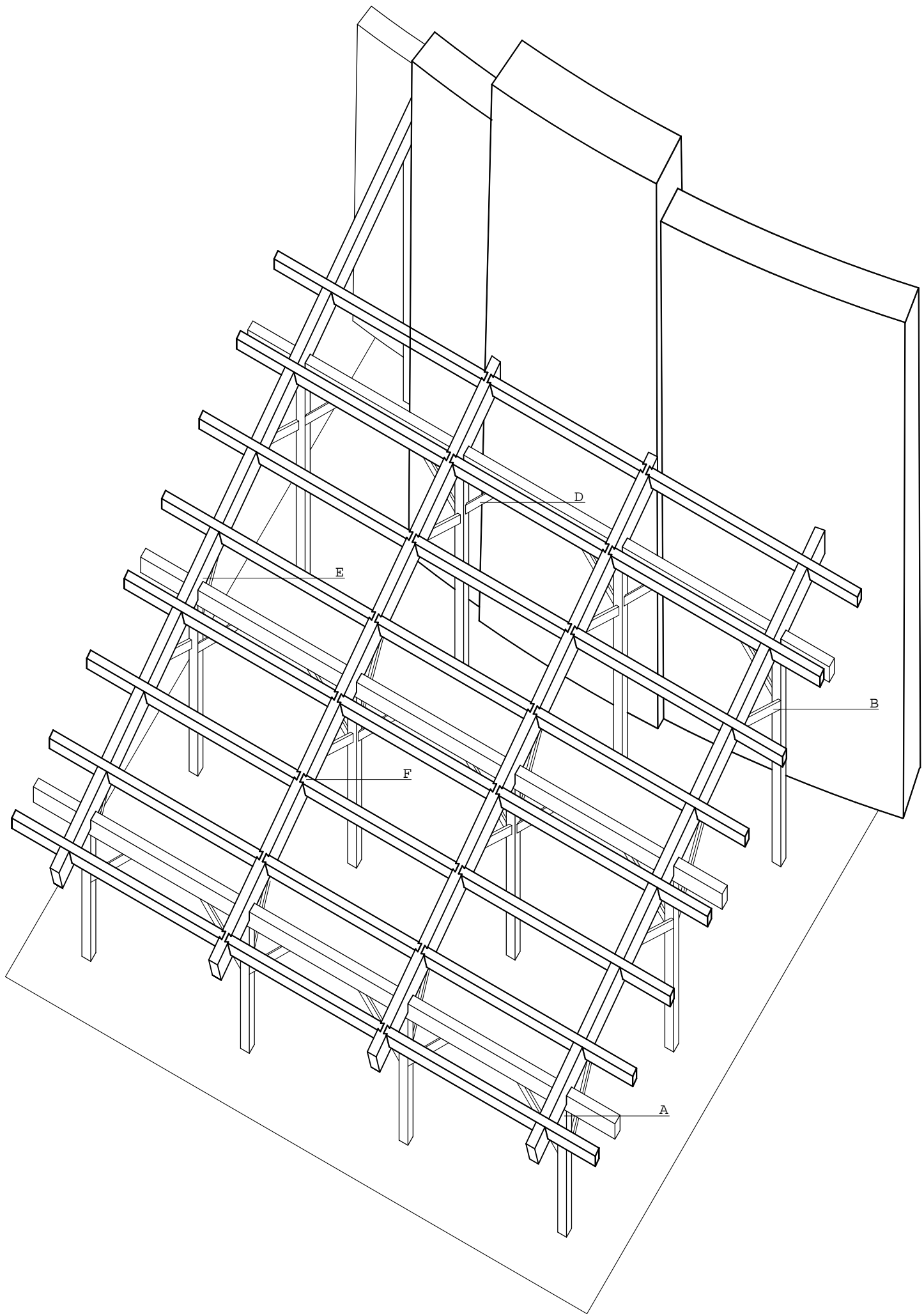

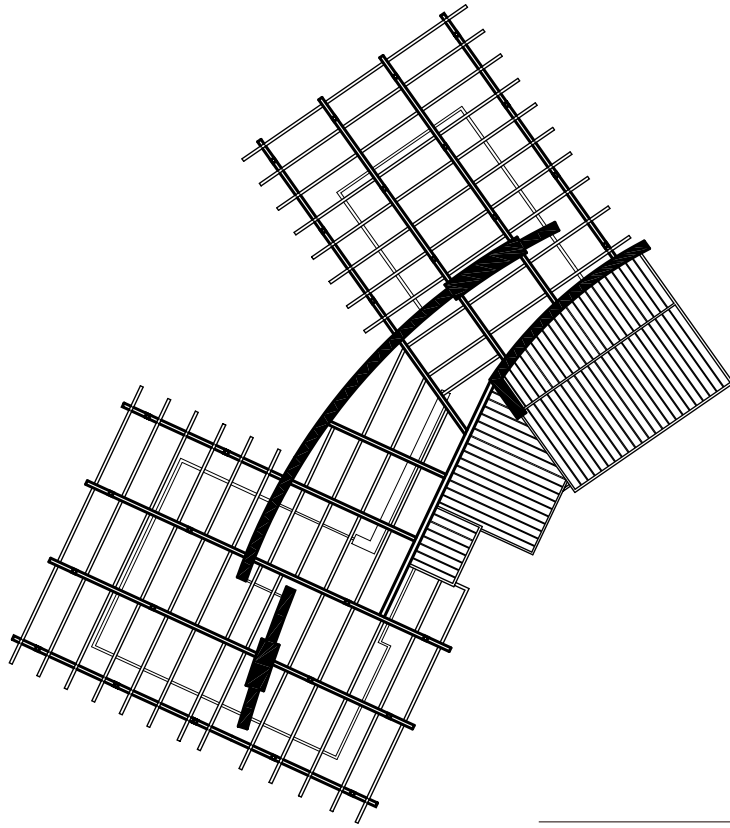

Roof

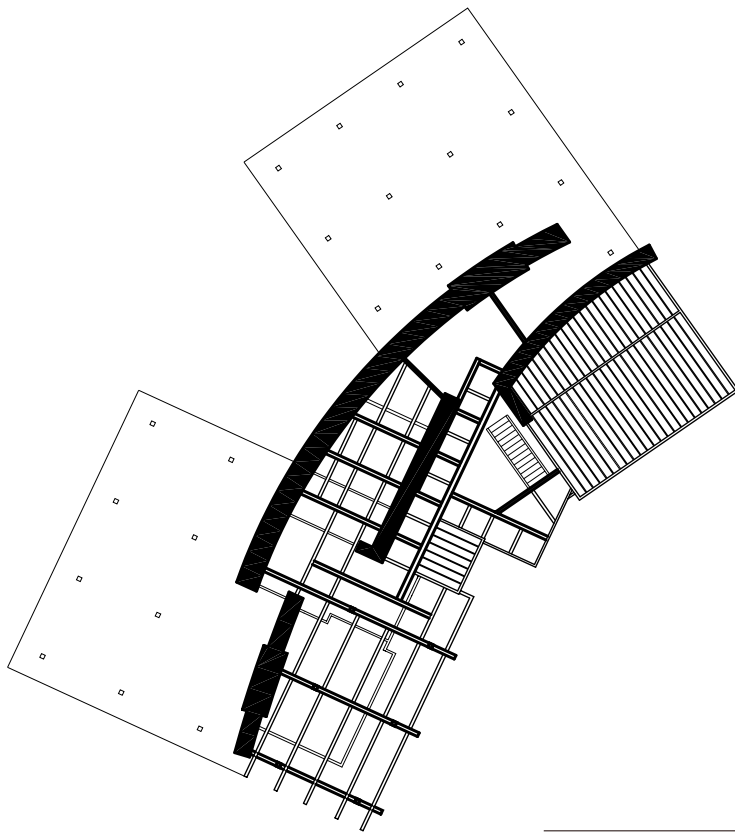

Second Floor

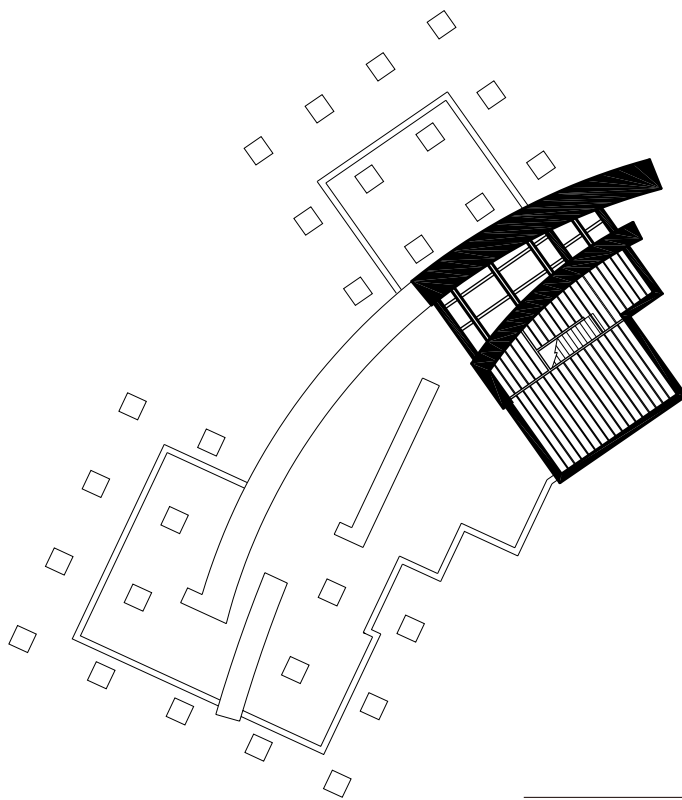

First Floor

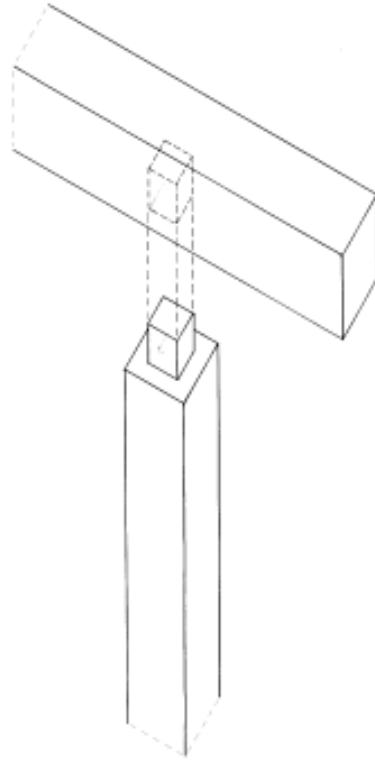

Beam to Post - a

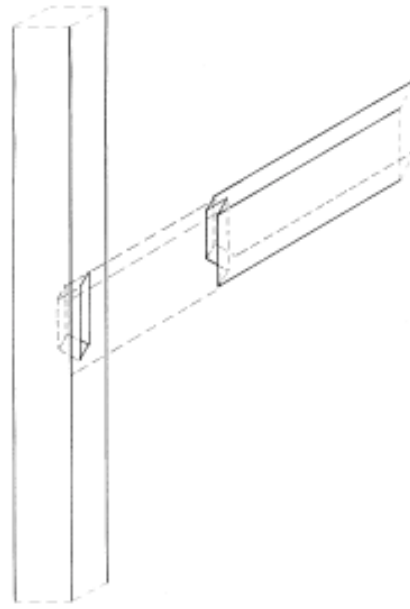

Exterior Bracing - b

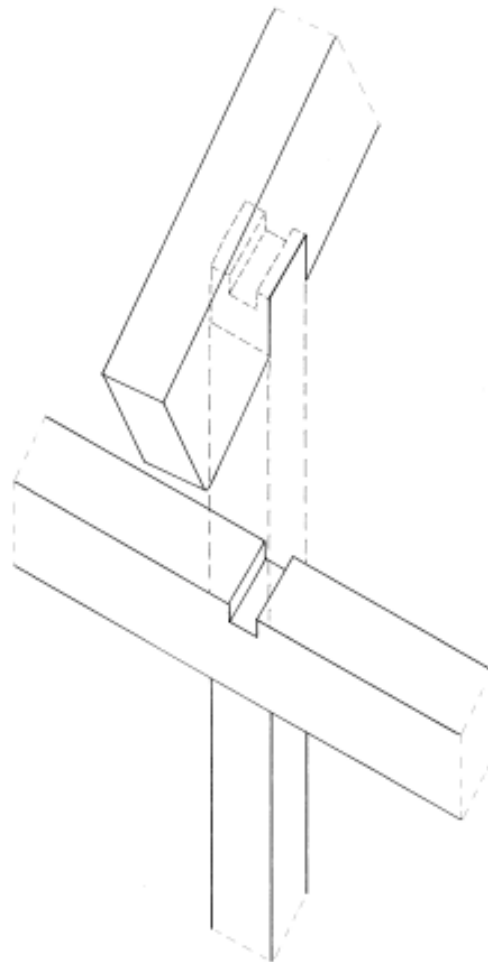

Rafter to Beam - c

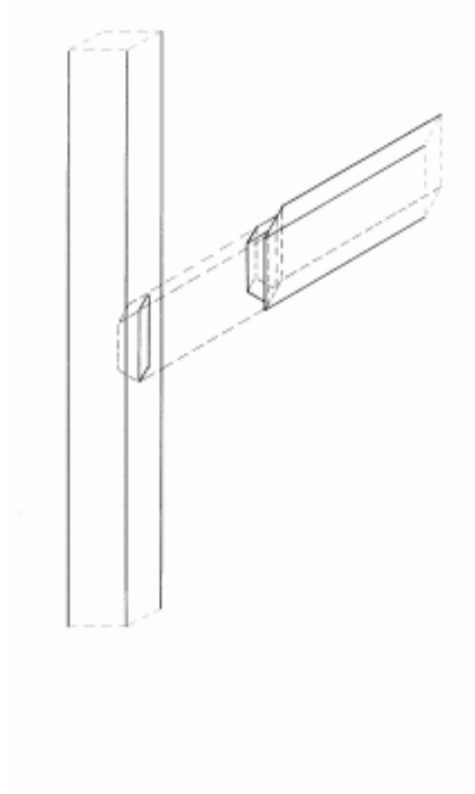

Interior Bracing - d

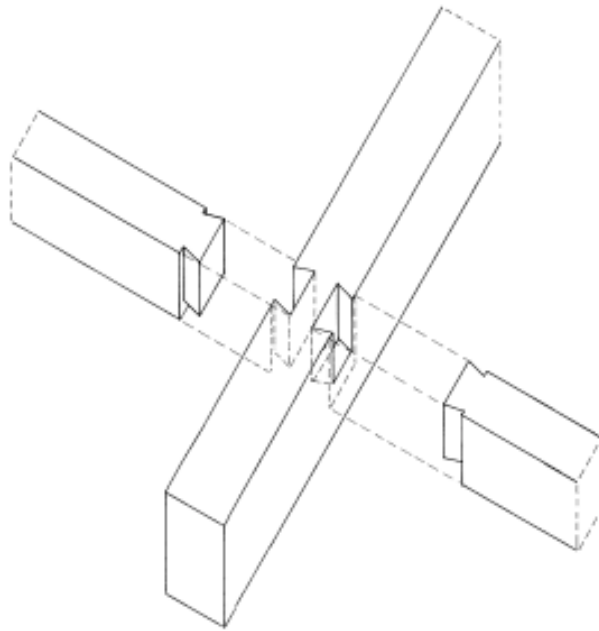

Purlin to Rafter - e

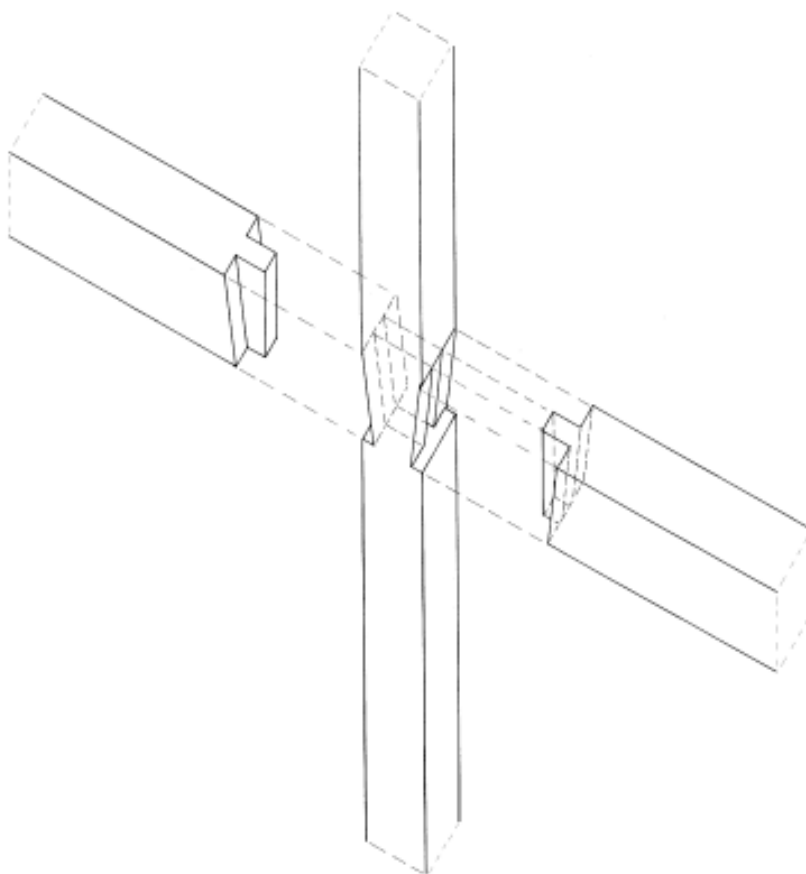

Floor Joist to Post

In this drawing of the interior living space and covered exterior porch, the relationship between the column and the wall is shown. The timber columns are placed at least 3 feet from the exterior wall, allowing the visitor to walk around the column and experience its presence in the room.

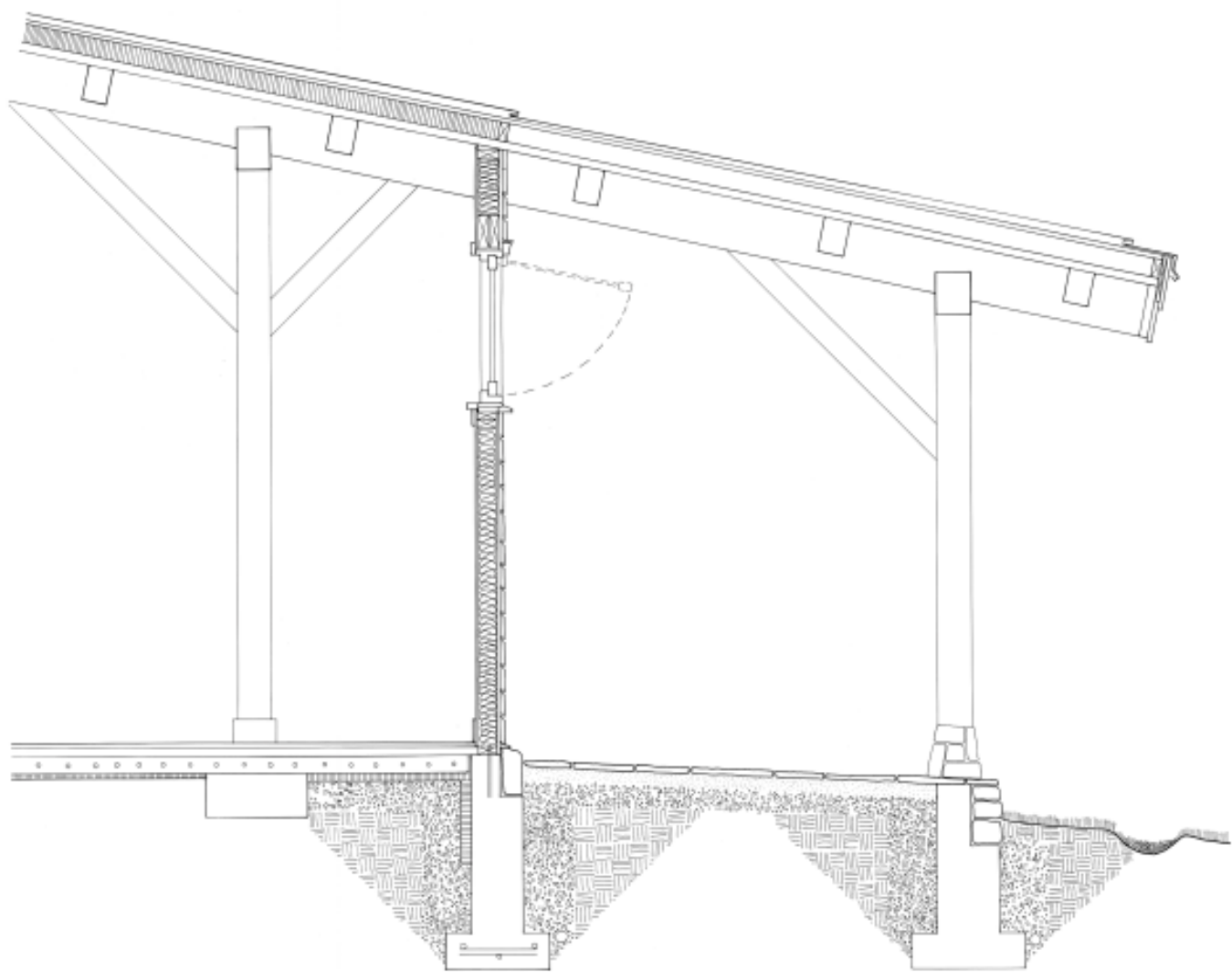

A section drawing through the proprietors quarters and the living room illustrate the differences in construction methods. The private proprietors area is framed using 2x4 light framed walls that are separated from the timber framed living room by the massive stone walls.

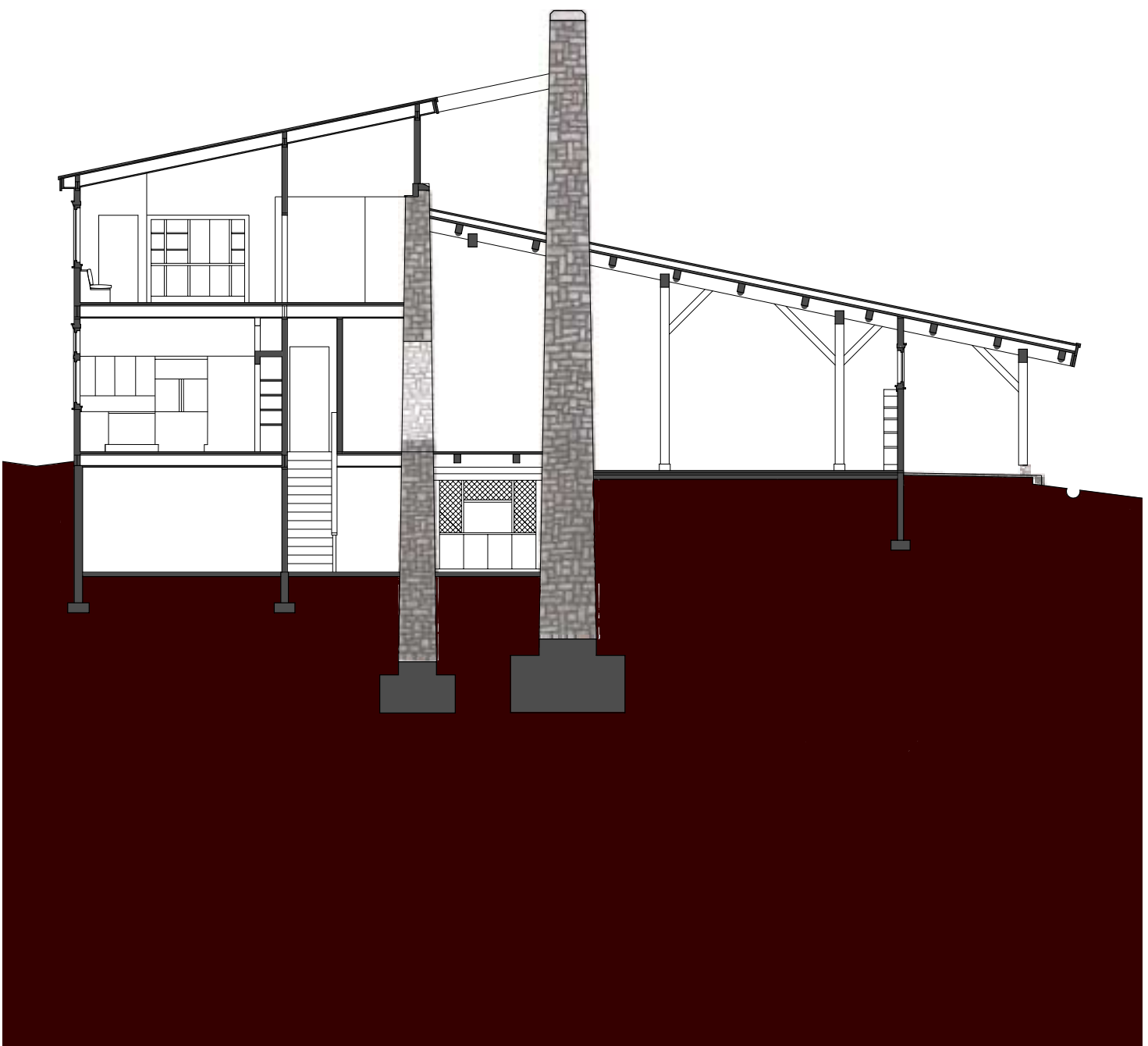

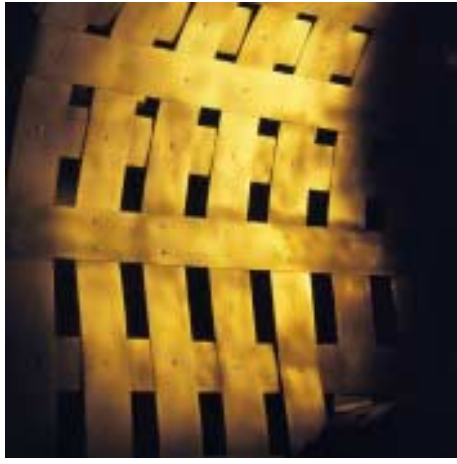

Light

“As the earth turns toward late afternoon, something special takes place. The room fills with light until it can hold no more, and in this fullness is transfigured. For this moment and a short while longer, there seems to be more than wood and plaster, line and plane. There is harmony, radiance, and a bittersweet glimpse of something like grace. It happens this way every day as the room turns toward the light. It has happened this way for some fifty thousand days since this room was new in 1831.”

Linda Butler on a room in the Hancock Shaker Village

Light as a Material

Each day that the sun shines, materials of a building are brought to life. As the day passes, the sun's rays move across materials with delight. Wood glows as the grain is revealed, the coursing in stonework is enhanced by the shadows in the mortar. This wonder of time can change a room with the beauty of shadows and the transfer of color. In Claude Monet's series entitled *Grainstack* seasonal changes of light were recorded. Monet's paintings reveal color, shadow, and reflected light at different times of the day and season. Through this study the form remains constant as the light changes. In architecture as in nature, it is the materials that record the changes of light. The floors, walls, and ceilings become the canvas and light is the paint.

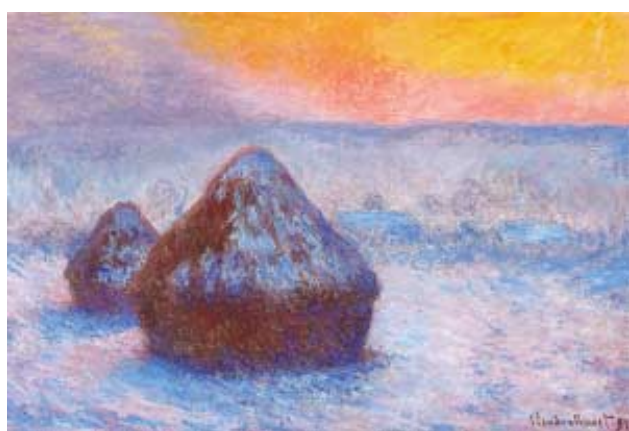



Sun's Energy and Shading

The sun's energy gives the stone walls the ability to store light as thermal energy. The walls can retain temperatures they have been exposed to for long periods of time. For example, cooler evening temperatures will extend over part of the heat of a summer day; and the warmth of the late afternoon is carried over into the cool early evening air. The result of this process is to even out the extremes. In this project the west facing stone walls will utilize this process directing the energy toward the main living areas. Other stone surfaces will affect a guest room on the second floor and a sitting room for the proprietors. The aforementioned surfaces will get direct sunlight in the morning and evening.



The overhangs of the building provide shade for the porches and the interior rooms. In the summer months during the hottest part of the day, the overhangs will shade windows on the south elevation, keeping guest rooms cool. The exterior porches will have shade most of the day until the sun goes down bringing in the beautiful colors of the sunset. During the winter when the sun is lower in the sky the sun will shine into guest rooms on the south elevation bringing light into the covered porch areas.

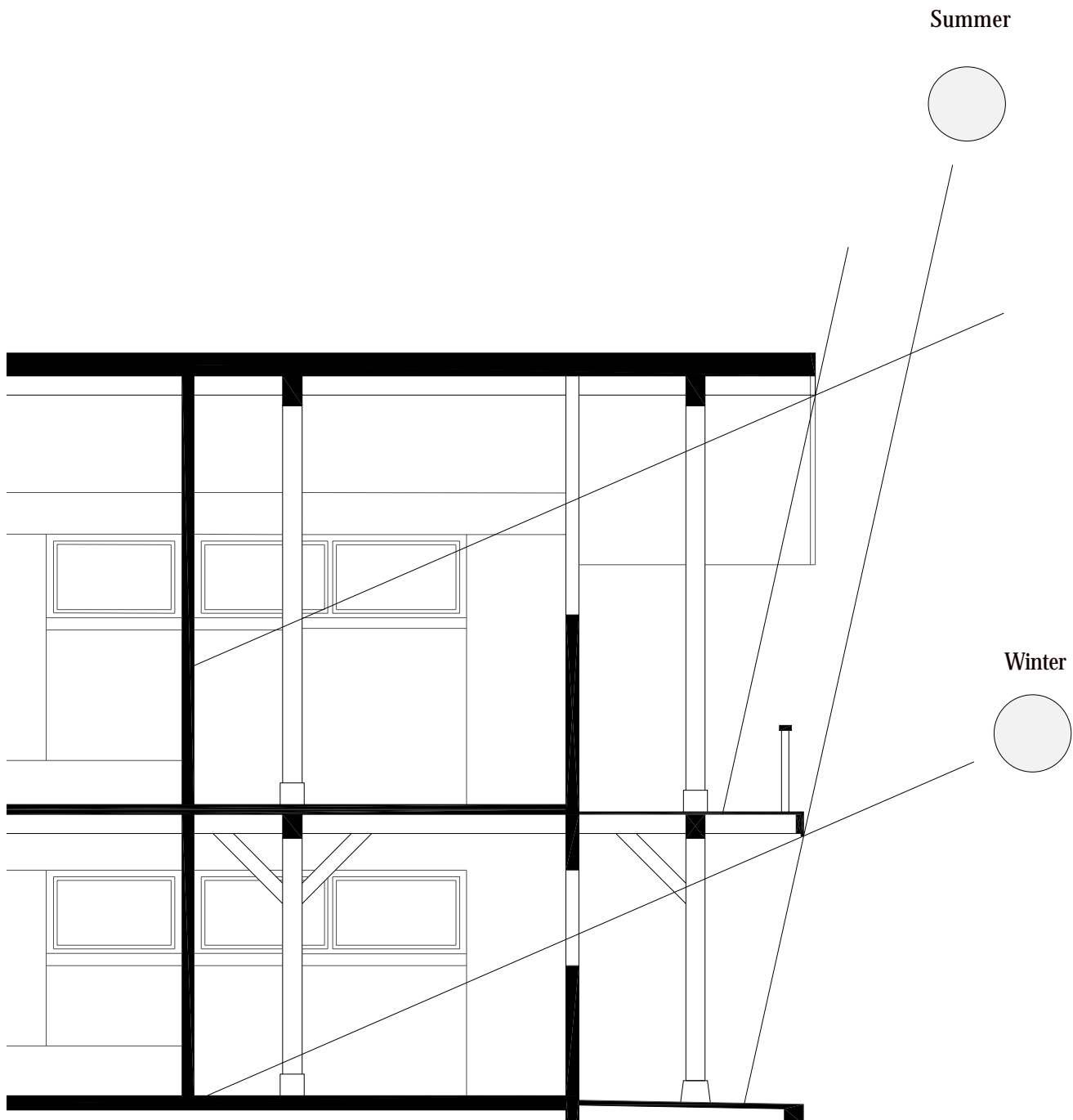



North Elevation- Entrance

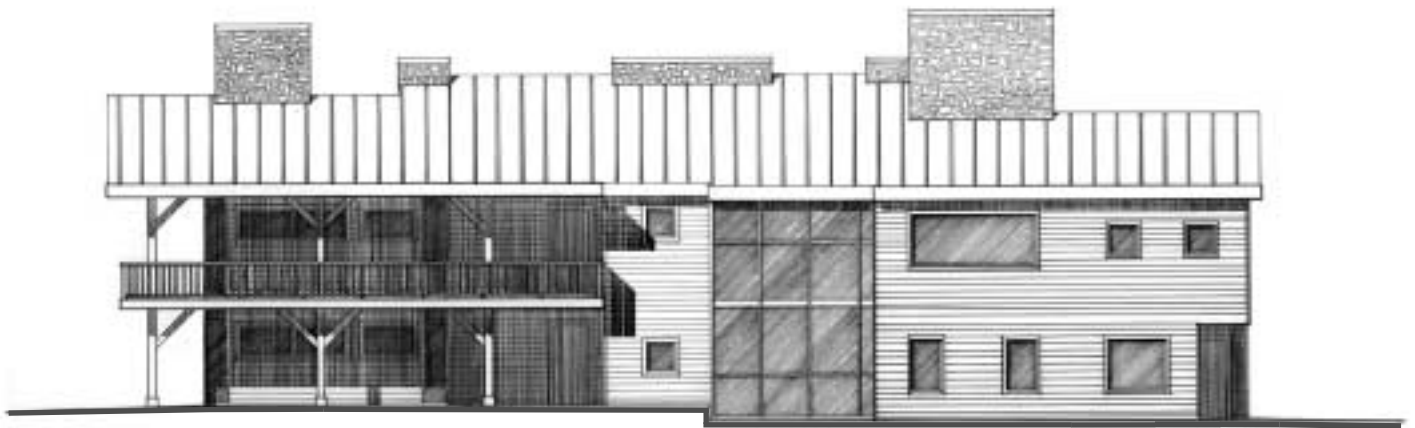

East Elevation- Forest View

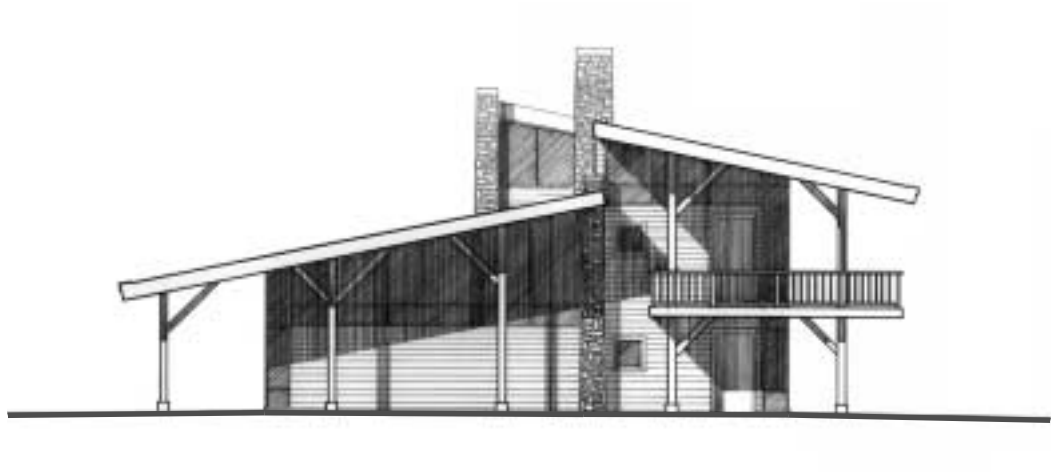

South Elevation - Guest Rooms



West Elevation - River View

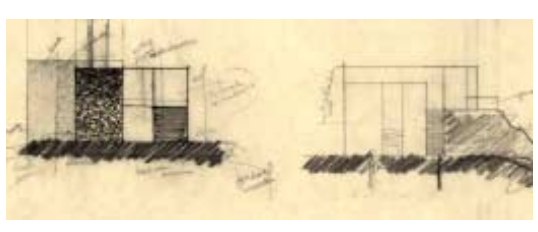
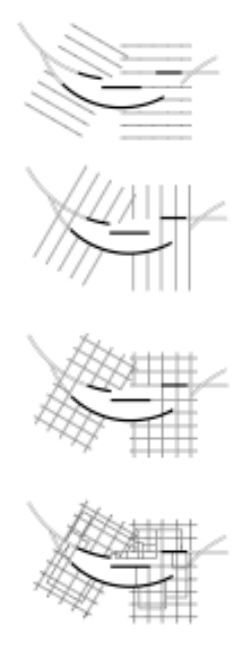
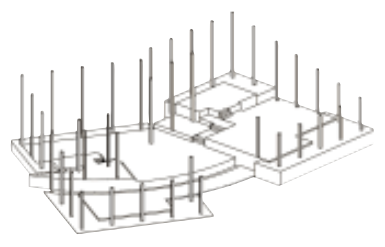
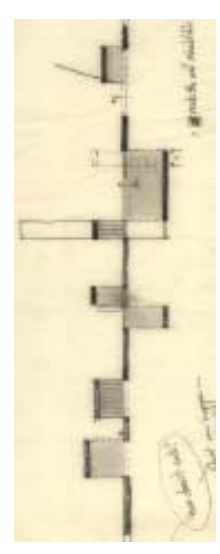
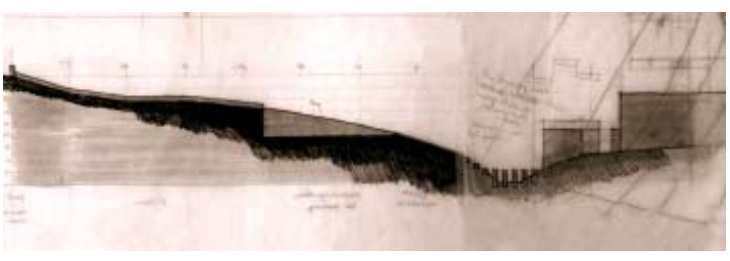
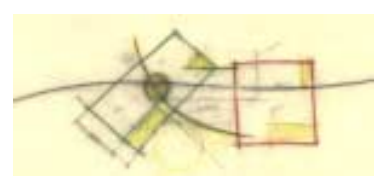
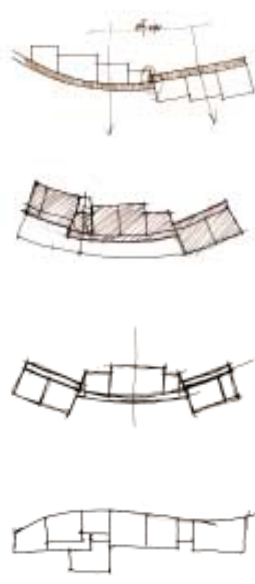

Conclusion

“We often think that when we have completed our study of one we know all about two, because ‘two’ is ‘one and one’. We forget that we have still to make a study of ‘and’.

A.S. Eddington

Using the above quote as reference, this thesis study has been a study of ‘one’. Many more years of study have yet to discover the meaning of ‘and’.

1	2
3	4
5	6
7	8

Nature- Page 8

1. Alex Organsky
2. 'Leaves' :Ansel Adams ,
An Ansel Adams Guide , pg 321
3. Charlotte Organsky
4. 'Aspens' :Ansel Adams ,
An Ansel Adams Guide , pg 275
5. Charlotte Organsky
6. John Organsky
7. John Organsky
8. Alex Organsky

17	18
19	20
21	22
23	24

Order - Page 30

17. Spiral Stairs II: Linda Butler, *Inner Light* , pg 51
18. White residence, Pinnacle, AZ: Antoine Predock,
American House Now , pg 116
19. Hallway Vincent James , *Type/Variant House* , pg 64
20. Ministry Shop Hallway:Linda Butler,
Inner Light , pg 3
21. Round Barn Interior:Linda Butler, *Inner Light* , pg 49
22. Autho
23. Mesa Public Library: Antoine Predock,
Antoine Predock: Architect 2 , pg 51
24. Author

33	34
35	36
37	38
39	40

Structure - Page 50

33. Detail: John Fitchen, *The New World Dutch Barn* pg 168
34. Author
35. Author
36. Author
37. Author
38. Guest House: Theresa Morrow ,*James Cutler* ,pg 63
39. Author
40. Detail: David Larkin, *The Essential Book of Barns* , pg 15

9	10
11	12
13	14
15	16

Site - Page 12

9. Old Dean Place: R.G. Wood, Virginia Library Archive, 1937
10. The Homestead, website
11. Author
12. Poor Farm House: R.G. Wood, Virginia Library Archive, 1936
13. John L.Landes Home: R.G. Wood,
Virginia Library Archive, 1937
14. Author
15. Author
16. W.J.Chestnut Home: R.G. Wood, Virginia Library Archive, 1937

25	26
27	28
29	30
31	32

Material - Page 42

25. Dwelling House Attic: Linda Butler, *Inner Light* , pg 12
26. St. Andrews Cour se Patricia Sellar,
RTKL : Selected and Current Works , pg 116
27. Author
28. Colum Base: Klaus Zwenger : *Wood and Wood Joints* , pg 23
29. Author
30. Large Chisel Called a Slick: David Larkin,
The Essential Book of Barns , pg 29
31. Exterior siding: Oscar Riera, *The new American house* , pg 181
32. Stone Floor: Linda Butler, *Inner Light* , pg 44

41	42
43	44
45	46
47	48

Light- Page 60

41. Meeting House Fence: Linda Butler, *Inner Light* , pg 7
42. Author
43. Main Interior Staircase, Pacific Palisades Residence:
American House Now ,pg 22
44. Gallery House: Chassay and Wilson, *The New Moderns* ,pg 169
45. Center For Integrated Systems, Stanford University:
Antoine Predock, *Antoine Predock: Architect 2* , pg 161
46. Author
47. Seadrift Lagoon House: Stanley Saitowitz,
American House Now , pg 199
48. Peg Shadows:Linda Butler, *Inner light* , pg 50

Credits

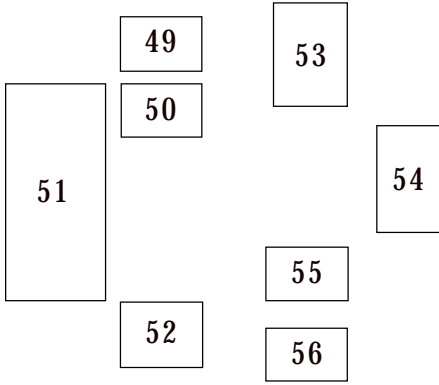

Page 10-11

- 49. Interior Camp 5 Point: Alex Organsky
- 50. Construction Camp 5 Point: Unknown
- 51. Forefathers Camp 5 Point: Unknown
- 52. Exterior Camp 5 Point: John Organsky
- 53. Alex Organsky
- 54. Author
- 55. Charlotte Organsky
- 56. Charlotte Organsky

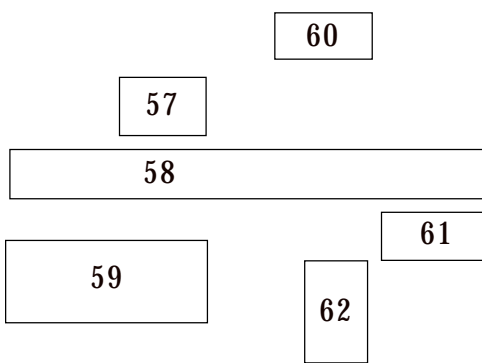

Page 14-15

- 57. The Homestead Resort: Website
- 58. Author
- 59. Author
- 60. Unknown
- 61. Author
- 62. Unknown

Pg 16-17. USGA Map

Pg 23. USGA Map

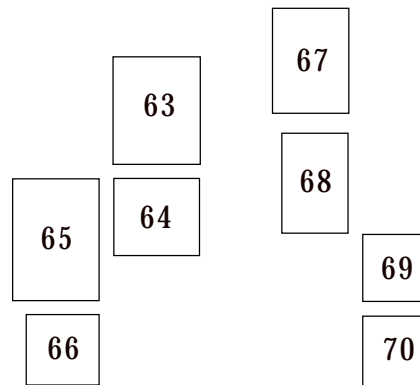

Page 48-49

- 63. Barn and Stone Wall: David Larkin, *The Essential Book of Barns*, pg95
- 62. Author
- 65. Interior :Ted Benson, *Timberframe*, pg 37
- 66. Raising: David Larkin, *The Essential Book of Barns*, pg 24
- 67. Spiral Stair: Linda Butler, *Inner Light*, pg 1
- 68. Interior : Herbert Ypma, *American Country*, pg 25
- 69. Built-in Cabinets: Linda Butler, *Inner Light*, Pg 12
- 70. Interior : Vincent James , *Type/Variant House*, pg 68

Pg 53. Interior :Ted Benson, *Timberframe*, pg 54



Page 62

- 71. 'Sunset Snow Effect', Claude Monet: Paul Tucker, *Monet in the 90's*, pg 84
- 72. 'Sunset', Claude Monet: Paul Tucker, *Monet in the 90's*, pg 31
- 73. Unknown

Notes

- Pg 9. Cerver, F.A.: *Rustic and Country Houses*, Introduction
- Pg 13. Krevitt, Charles: Poem in *Connections*, pg 37-38
- Pg 21. Ellis, Tom: Source Unknown
- Pg 31. Grant, Carl: *Tao of Design*, pg xliii
- Pg 48. Calviro, Italo: *Invisible Cities*, pg 82
- Pg 51. Hughes, Dean: Source Unknown
- Pg 61. Butler, Linda: *Inner Light*, Introduction
- Pg 73. Raskin, Eugene: *Architecturally Speaking*, pg 86

Unless otherwise noted, photos and work are by the author.

- Arthur, Eric Ross
The Barn; A Vanishing Landmark in North
Greenwich, CT: New York Graphic Society, 1972
- Barnes, Christine
Great Lodges of the West
Bend, OR: W.W. West, Inc., 1997
- Benson, Ted
The Timber-Framed Home
Taunton Press, Inc., 1997
- Benson, Ted.
Timberframe.
Taunton Press, Inc., 1999
- Blaser, Werner
Wood Houses
Basel, NY: Wepf, 1980
- Brookes, John
A Place in the Country
New York, NY: Thames and Hudson, 1984
- Butler, Linda
Inner Light : The Shaker Legacy
New York, NY: Knopf, 1985
- Bye, A. E.
Art Into Landscape, Landscape Into Art
Mesa, AZ: PDA Publishers Corp., 1983
- Cerver, F.A.
Rustic and Country Houses
Watson-Guptil Pub, 1997
- Chermayeff, Serge
Community and Privacy;
Garden City, NY: Doubleday, 1965
- Cohen, Stan
The Homestead and Warm Springs Valley
WV: Pictorial Histories Pub. Co., 1984
- Cole, William
A Book of Nature Poems
New York, NY: Viking Press, 1969
- Calvino, Italo
Invisible Cities
FL: Harcourt Brace Jovanovich Pub, 1974
- Dal Co, Francesco
Villa Ottolenghi : Carlo Scarpa
New York, NY: Monacelli Press, 1998
- Doubilet, Susan and Boles, Daralice
American House Now
Universe Publishers, 1997
- Emerson, Ralph Waldo
The Essays of Ralph Waldo Emerson
Cambridge, MA: Belknap Press, 1987
- Fitchen, John
The New World Dutch Barn
Syracuse, N.Y: Syracuse University Press, 1968
- Frome, Keith
Hitch Your Wagon To A Star
New York, NY: Columbia University Press, 1996
- Garant, Carl G.
The Tao of Design
Atlanta, GA: Humanics Ltd., 1998
- Glancey, Jonathan
The New Moderns
New York, NY: Crown, 1990
- Greene, Herb
Mind & Image : An Essay On Art & Architecture
Lexington, KY: University Press of Kentucky, 1976
- Ingalls, Fay
The Valley Road
Cleveland, OH.: World Pub. Co., 1949
- James, Vincent
Type/Variant House
Rockport Publishers, 1999
- Jensen, Jens
Siftings
Baltimore, MD: Johns Hopkins Univ. Press, 1990
- Klamkin, Charles
Barns; Their History, Preservation, and Restoration
New York, NY: Hawthorn Books, 1973
- Knevelt, Charles
Connections : The Architecture of Richard England
London: Lund Humphries, 1984
- Larkin, David
The Essential Book of Barns
New York, NY. : Universe Pub., 1995
- Larkin, David
The Essential Book of Rural America
New York, NY: Universe, 1996
- Lyndon, Donlyn and Moore, Charles
Chambers for a Memory Palace
Chicago, IL: MIT, 1997
- Mc Raven, Charles
Stonework, Techniques and Projects
Vermont: Storey Books Pownal, 1997
- Millet, Marietta
Light Revealing Architecture
New York, NY: Van Nostrand Reinhold, 1996
- Moore, Charles
The Place of Houses
New York, NY: Holt, Rinehart and Winston, 1974
- Moore, Ruble, Yudell
Moore Ruble Yudell : Houses & Housing
Washington, D.C.: AIA Press, 1994
- Morrow, Theresa.
James Cutler
Rockport, MA: Rockport Pub., 1997

Bibliography

Plummer, Henry

Light in Japanese Architecture

Tokyo: E ando Yu, 1995

Predock, Antoine

Antoine Predock, Architect 2

New York, NY: Rizzoli, 1998

Raskin, Eugene

Architecturally Speaking

New York, NY: Bloch Publishing Co., 1966

Riera, Oscar

The New American House

New York, NY: Whitney Library of Design, 1995

Schwenke, Karl and Sue

Build Your Own Stone House

Charlotte, VT: Garden Way Pub., 1975

Schaefer, John P.

An Ansel Adams Guide

Little Brown & Co., 1999

Strand, Janann

A Green & Greene Guide

Pasadena, CA: G. Dahlstrom, 1974

Thoreau, Henry David

Walden

Book-of-the-Month Club, 1996

Tucker, Paul Hayes

Monet in the '90s

New Haven, CT: Yale University Press, 1989

Visser, Thomas Durant

Field Guide to New England Barns and Farm Buildings

Hanover, N.H: Univ. Press of New England, 1997

Vivian, John

Building Stone Walls

Charlotte, VT: Garden Way Pub., 1976

Ypma, Herbert

American Country

New York, NY: Stewart, Tabori & Chang, 1997

Zumthor, Peter

Thinking Architecture

Lars Muller Publishers, 1998

Zwerger, Klaus

Wood and Wood Joints

Basel,Boston: Birkhauser, 1997



Acknowledgments

I would like to thank the following people for without their support and encouragement none of this would have been possible.

To my committee: Bill, Mike, and Warren - Thank you for your continual criticism, guidance, and patience throughout this thesis journey. Thank you for your part in developing my architectural abilities and passion.

Bill Galloway: Thank you for all your help and for being there for my defense on such short notice.

Mom, Dad, and family: Thank you for all your love, support, and helping me to fulfill my goals and dreams.

Clint: Thank you for your love, patience, and confidence that the 'end' would come even when I wasn't certain it would.

The 3+ group and other friends: Thank you for all the support and discussions about my work. Thank you for your faith and confidence which gave me the courage and determination to wrap things up. Thank you for putting up for my need for great amounts of desk space.

Irene: Thank you for all your insight on architecture, presentation, and editing skills, as well as our endless discussions about life.

Barrow: Thank you for you help in the woodshop and for the use of your printer, without which this book would not have been printed.

Claudia: Thank you for all the times 'puppy camp' was in session. 'We' will both miss it.

Vita

Jennifer Ann Organsky

Born February 3, 1972

Norristown, PA

Graduate Education

Master of Architecture

Virginia Polytechnic Institute and State University, 2001

Study Abroad

Virginia Tech

Center for European Studies and Architecture, 1996

Undergraduate Education

Bachelor of Science in Interior Design

Drexel University, Nesbitt College of Design Arts, 1994