



# TECHNICAL MANUAL

## LABOUR-BASED ROAD CONSTRUCTION METHODS



**First Edition**

*Prepared for the International Labour Organisation  
by*

**B** **Bjørn Johannessen**  
Engineering Consultant



Vientiane, August 1997

# Table of Contents

	<b>Introduction</b>	<b>1</b>
<b>1</b>	<b>Surveying and Setting Out</b>	<b>2</b>
	1.1 Road Selection	3
	1.2 The Profile Board Method	6
	1.3 The Centre Line	16
<b>2</b>	<b>Construction Procedures</b>	<b>25</b>
	2.1 Clearing	26
	2.2 Earthworks	28
	2.3 Embankment Construction	38
	2.4 Ditching, Sloping and Camber Formation	44
	2.5 Off Road Drainage	48
	2.6 Compaction	53
	2.7 Culverts	56
	2.8 Drifts	59
	2.9 Gravelling	63
	2.10 Erosion Protection	68
<b>3</b>	<b>Site Administration</b>	<b>69</b>
	3.1 Setting Up a Camp	70
	3.2 Hand Tools	72
	3.3 Materials	74
	3.4 Maintenance of Equipment	75
	3.5 Site Support Activities	76
<b>4</b>	<b>Work Organisation</b>	<b>77</b>
	4.1 Definition	78
	4.2 Work Programming	78
	4.3 Recruitment and Employment of Labour	81
	4.4 Inspection and Supervision	84
	<b>Annex 1 References</b>	<b>86</b>

# Introduction

---

**T**he purpose of this manual is to provide technical staff from supervisors to engineers with a field reference which in detail explains and prescribes the work methods and technical standards applied when constructing rural roads using labour-based methods in Lao PDR.

Labour-based methods can be defined as the construction technology which, while maintaining cost competitiveness and acceptable engineering quality standards, maximises opportunities for the employment of labour (skilled and unskilled) together with the support of light equipment and with the utilisation of locally available materials and resources.

When considering the use of labour-based technology in road works projects, it is important to acknowledge its limitations. In some circumstances, traditional equipment-based work methods are more effective and may provide higher quality outputs, such as large excavation works, rock excavation and haulage of materials over long distances.

Although the technology may be unknown for many of the collaborators in the Lao rural road sector, it has been successfully tested and adapted to the specific conditions in Lao PDR through the ILO labour-based road project in Oudomxay and Savannakhet during the last two years. This manual attempts to document the work methods as carried out in the ILO project.

The manual is divided into four parts. It describes standard setting out methods, construction procedures, site administration and work organisation. These four topics covers the technical skills which are required from supervisory staff responsible for carrying out rural road construction and rehabilitation works as practised in the ILO project.

This is the first version of the manual, and field staff are encouraged to suggest additions and changes to the manual in later versions.

Bjørn Johannessen

5 August 1997

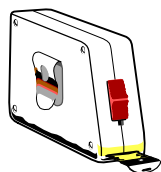

# Chapter 1

## Surveying and Setting Out

<b>1.1</b>	<b>Road Selection</b>	<b>3</b>
	Technical Feasibility	3
	Criteria for Economic Justification	3
	Social Criteria	4
<b>1.2</b>	<b>The Profile Board Method</b>	<b>6</b>
	The Basic Principle	6
	Equipment	7
	The Traveller	7
	The Line Level	7
	Other Equipment	9
	Temporary Travellers	11
	The Use of Profile Boards	12
	Side Drains	12
	Vertical Curves	12
	Cross Sections	13
	Slopes	13
	Length of a Mitre Drain	15
<b>1.3</b>	<b>The Centre Line</b>	<b>16</b>
	Road Alignment	16
	Setting Out Straight Lines	17
	Setting Out Curves	18
	The Intersection Method	18
	Adjusting the Position of the Curve	20
	Setting Out Curves "by Eye"	21
	Off-set Pegs	21
	Vertical Alignment	22
	Road Gradients	23

## 1.1 Road Selection

Ideally, the selection and prioritisation of individual rural road construction and rehabilitation projects should at first be carried out before the choice of technology is decided upon. Basically, there are three criteria which needs to be considered:

- (i) technical feasibility,
- (ii) economic justification and
- (iii) social considerations.

Once the road priorities have been made and the detailed road alignments have been identified, it is possible to establish the correct mixture of labour and equipment-based work methods.

### (ii) Technical Feasibility

- The road must connect to a well-maintained engineered road, thereby adding on to the existing functionable road network in the region.
- When considering a new project it is important to make a rapid assessment of the future road alignment, investigating the need for expensive structures such as bridges, heavy earth works through rocky and steep terrain, and difficult soil types, etc.
- Building materials such as gravel and water should be available in a reasonable distance.
- Facilities for future maintenance (labour, tools, equipment and supervision) must be available.
- There should be sufficient funds available to continue periodic and routine maintenance.
- If labour-based work methods is a prerequisite (e.g. on Food for Work programmes), then a minimum of 100 persons should be available and willing to work for the project under the terms and conditions offered.

### (ii) Criteria for Economic Justification

Various investment models are available to carry out the economic analysis. The benefits normally considered in an economic evaluation are:

- direct savings in the cost of operating vehicles,
- economies in road maintenance costs,
- time savings by travellers and freight,
- reductions in road accidents (although these often *increase* on improved roads), and
- wider effects on the economic development of the region.

Investment models are also available to estimate the total transport costs associated with different road surfaces including vehicle operating costs, maintenance costs and renewal costs under a variety of traffic, climatic and maintenance conditions.

Rural roads, however, represent the grass roots of the road network which feed traffic into the secondary and primary roads opening access to the rural areas. Rural roads have low traffic volumes and are generally constructed with gravel surfaces. For these roads, the economic justification for the investment rests mainly on the expected impact on social and agricultural development. Both these outputs are time related and have a large element of uncertainty.

The extent to which the local economy adjacent to the proposed road will benefit from the investment is dependent on its economic potential such as unused land, irrigation facilities and labour, transportation facilities and costs. To forecast an increase in agricultural production, producer surplus and assessment of resultant producer benefits is a complex and difficult task.

This effect on the economy is extremely difficult to predict and virtually impossible to model, and any assessment made will have a high element of uncertainty, and relies on a series of external factors.

In terms of maintenance economics, there are, however, clear guidelines which can be followed. A basic rule for any road works programme is to protect previous investments and therefore to allocate available funds according to the following order:



- (1) First, provide routine maintenance to the sections of the network which is in a good and maintainable condition. "Good" condition is regarded as when the road section requires a minimum of routine maintenance, which can be provided through a lengthman system.
- (2) Secondly, provide spot improvements and periodic maintenance to halt the deterioration of road sections in fair condition, thereby upgrading them to a maintainable condition.
- (3) Thirdly, rehabilitate existing roads which has fallen into total disrepair.
- (4) Once the three activities above have been secured, including regular maintenance for the newly upgraded road sections, one should be looking into new construction and expanding the road network. Once again, new projects should only be accepted when sufficient maintenance resources are available or can be secured when the construction of the new roads have been completed.

### (iii) Social Criteria

The following are amongst the social criteria that may be used for ranking rural road rehabilitation projects:

- Present condition of the road. Communities without any access should be given high priority. The better the existing access, the lower the priority.

- The availability of access year - round. Communities without access only during some parts of the year should have high priority.
- The area influenced by the road. The larger the area of influence, higher the priority. The correct determination of the area served is important but is difficult to identify. The limits of the area are generally provided by watersheds, rivers or the proximity of adjacent roads. In the situation of rural roads in Lao PDR, the area within walking distance of two hours from the proposed road can be taken.
- The inhabitants served. The greater the number of inhabitants to be served, the higher the priority.
- Present transportation costs per km. Road transport costs are related to the road condition. The higher the present costs, more these costs will decrease by road improvements.
- The area of cultivable land within the area of influence. A rural road programme should benefit as many farmers as possible. Roads leading to fewer farms and houses should be given lower priority.
- Increased area of cultivable land. By improving access, the inhabitants may be encouraged to cultivate more land within the area of influence of the road.
- Orientation of local produce to the market. The greater the volume of marketable produce, higher should be the priority for road improvement.
- The potential increase in marketable production. Increased production is related to road conditions, because improved access to markets will encourage the inhabitants to produce more goods to sell.
- The availability of social and economic services. Most of the social and economic services (medical, educational, and agricultural inputs) end where the trafficable road ends and go no further. Improved access can extend these services to isolated communities.

From the above, it is clear that a certain volume of data needs to be collected before a ranking can be established. Furthermore, it is also evident that some of the criteria may be in conflict with each other (i.e. maintenance economics versus areas without road access). It is therefore important that the political leadership in the rural areas are fully involved in the final weighting of the criteria and final selection of projects to be included in the provincial road works programmes.

In this respect, the ILO IRAP project in collaboration with the Rural Development Committees has collected some very useful experience, both in terms of an appropriate methodology for data collection as well as establishing road works priorities in the context of an overall rural infrastructure development plan.

## 1.2 The Profile Board Method

### The Basic Principle

A commonly used setting out procedure is based on the use of a series of profile boards and a string line level giving control of levels during construction. As a result, the method has become known as the "Profile Board Method".

The basic principle when using profile boards is that when we set them out we are putting up a series of level boards that show us the level 1 metre above the completed construction levels. With practice, it becomes easy to work with these tools and roads can be built properly, economically and at high quality standards.

Imagine that you need to dig a ditch from A to B at the level shown in by the dotted line:

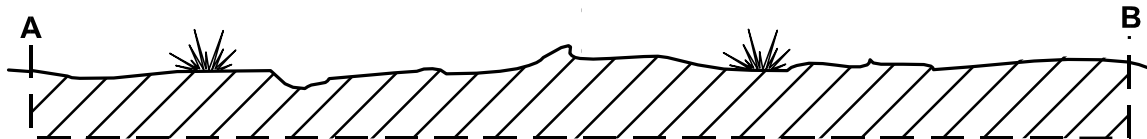

To ensure that we obtain the correct level in the ditch, we would put up profile boards at positions A and B, 1 metre above the level we want the ditch to be:

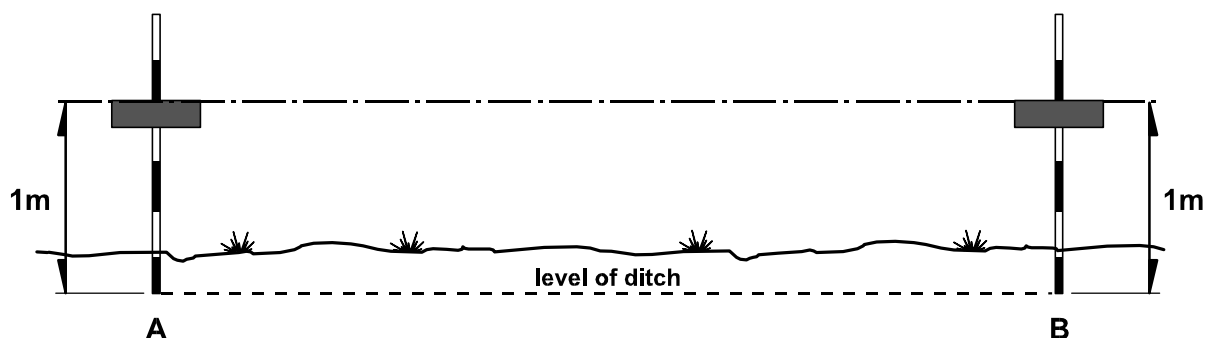

## Equipment

### The Traveller

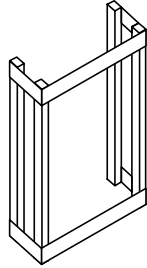

We need a third profile board that we can move around. It is known as the travelling travelling profile or *traveller*. Along the line from A to B, we excavate slots to the level of the ditch. If we place the traveller in a slot and sight from profile board in position A to the profile board in position B, we can see if the traveller lines up with the two fixed profile boards. If the traveller is too low, the slot has been dug too deep. If the traveller sticks up above the sight line, the slot needs to be dug deeper.

To provide good guidance, slots are dug at regular intervals, say at every 4 to 5 metres along the sight line.

When sufficient slots have been dug, the workers can start excavating the ditch by joining up the slots. The traveller can then be used to check that the finished work is to the correct level and that there are no high or low spots.

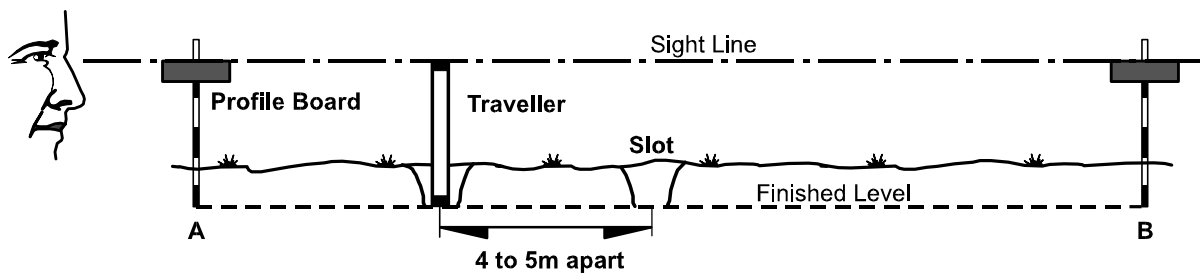

### The Line Level

The level of each of the profile boards can be controlled by using a *line level*. The line level is a short spirit level (about 100 mm long) with a hook at each end to hang it from a nylon string.

This instrument needs two persons to operate - one at the end of the line, and the second to watch the spirit level. The line operator moves the string up or down until the bubble is centred in the middle between the spirit level marks. The string line will then indicate the horizontal line.

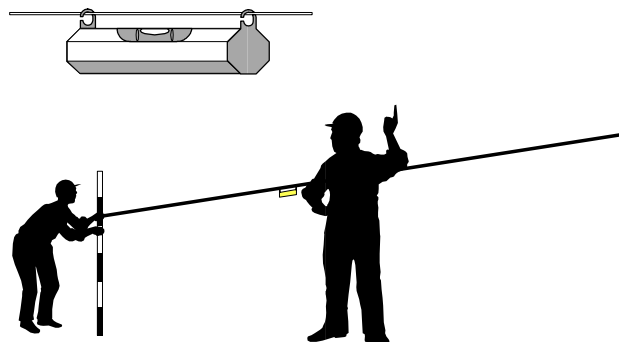

The line level can be used to:

- transfer the exact level of one profile board to another profile board, thereby ensuring that both are at the same level,
- measure up or down from the horizontal level shown, and set another profile board so that there is a certain difference of level between the two profiles, and
- find the slope between two fixed profile boards, and which one is higher.



Points to remember when using a line level:

- ✓ The string used should be a thin nylon fishing line, enabling the line level to easily slide along the string.
- ✓ The line level must be placed half-way between the two ranging rods. Use a measuring tape to find the exact middle point.
- ✓ Keep the string tight - do not let it sag.
- ✓ The line level is an delicate instrument, look after it - do not throw it around and treat it roughly.
- ✓ Check the accuracy of the line level regularly in the field.

### Checking the Line Level

Take two ranging rods across the road and transfer a level from one rod to the other. Mark the level on the second rod. Then keeping the string in the same position on the first rod, take the line level and turn it around on the string. Adjust the string on the second rod until the bubble is in the middle again and mark the new level. Check to see if the two marks are at the same place. If not, measure the difference between the two marks. If the difference between the two marks is less than 10 cm, you can get the right level by taking the point half way between the two marks. If the difference is greater than 10 cm you should replace the line level for an accurate one. It is always a good idea to turn the line level around every time you use it and take the middle of the two marks as the horizontal level.

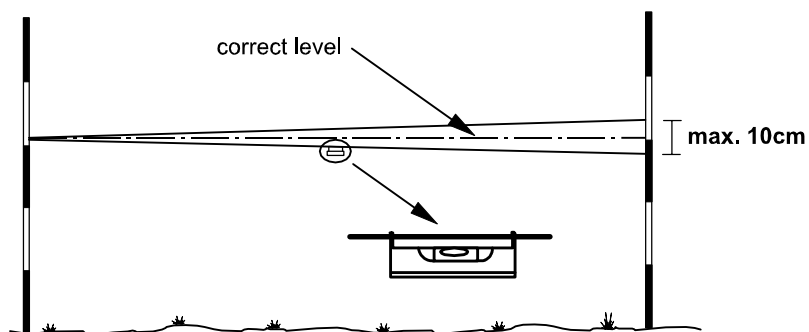

The line level has a range of up to about 50 metres. It is easy to carry around and with care can be used for setting out levels and slopes not less than 1 in 300.

## Other Equipment

The other requirement of the profile method is the use of adjustable profiles that can be moved and locked in the desired position.

A long lasting profile board is made from thin steel plate which is welded to a short length of metal tubing that can slide up and down and be clamped to a metal ranging rod. A useful size for the metal profile boards has been found to be 40 cm by 10 cm, painted red to make it easy to be seen.

The ranging rods are made of hollow metal tubes, often 12.5mm diameter galvanised water pipe, with a pointed end of sharpened reinforcement steel. They are painted red and white to make them easy to see during setting out.

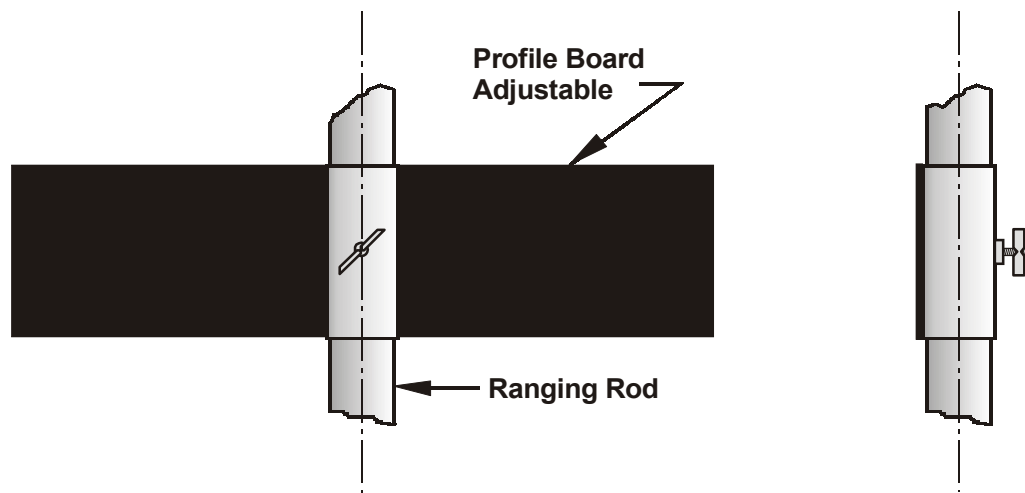

A very useful additional tool is a *sliding hammer* with a weighted head that fits over the ranging rod and can be used to drive the ranging rod into the ground.

The traveller can be made of wood or metal, although metal is desirable as they are frequently and roughly used and should therefore be of strong construction.

In very compact, or rocky ground, it is useful to first make a hole for the ranging rod by first producing a hole by hammering down a metal spike produced from high tensile reinforcement steel. Crow bars can also be used for this purpose.

The profile boards, ranging rods and travellers are inexpensive and can easily be made by a local metal work business.

Before starting your setting out works, make sure that you have a sufficient supply of ranging rods and profile boards. A supply of 20 rods and 20 profile boards is regarded as a minimum to effectively carry out the job.

### Equipment Required for Setting Out

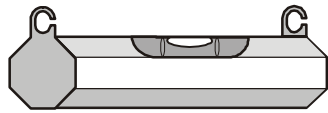

Line Level

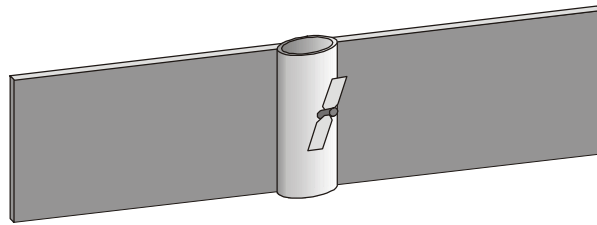

Profile Board

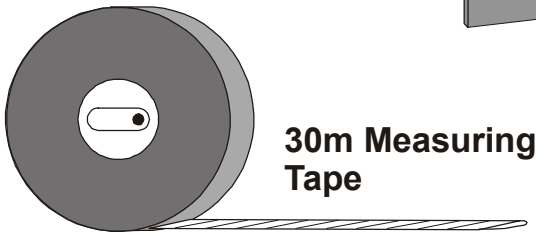

30m Measuring Tape

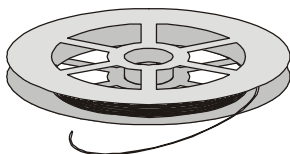

Nylon String



Club Hammer

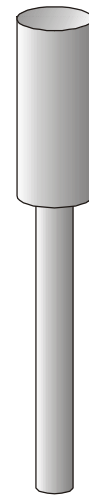

Sliding Hammer

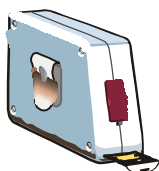

3m Measuring Tape

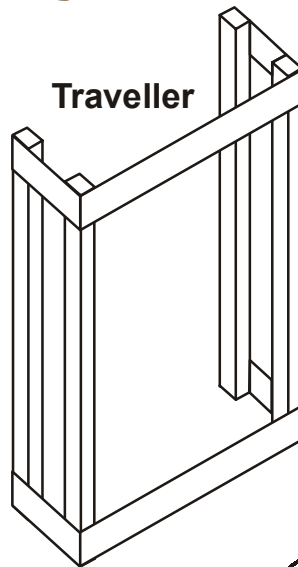

Traveller



Metal Spike

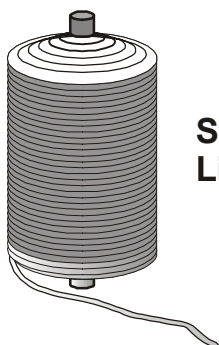

String Line

Ranging Rod

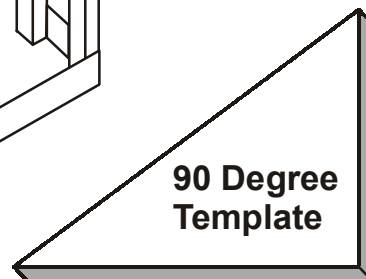

90 Degree Template

## Temporary Travellers

It is also possible to make measurements below the line sighted between two profile boards by using a *temporary traveller*.

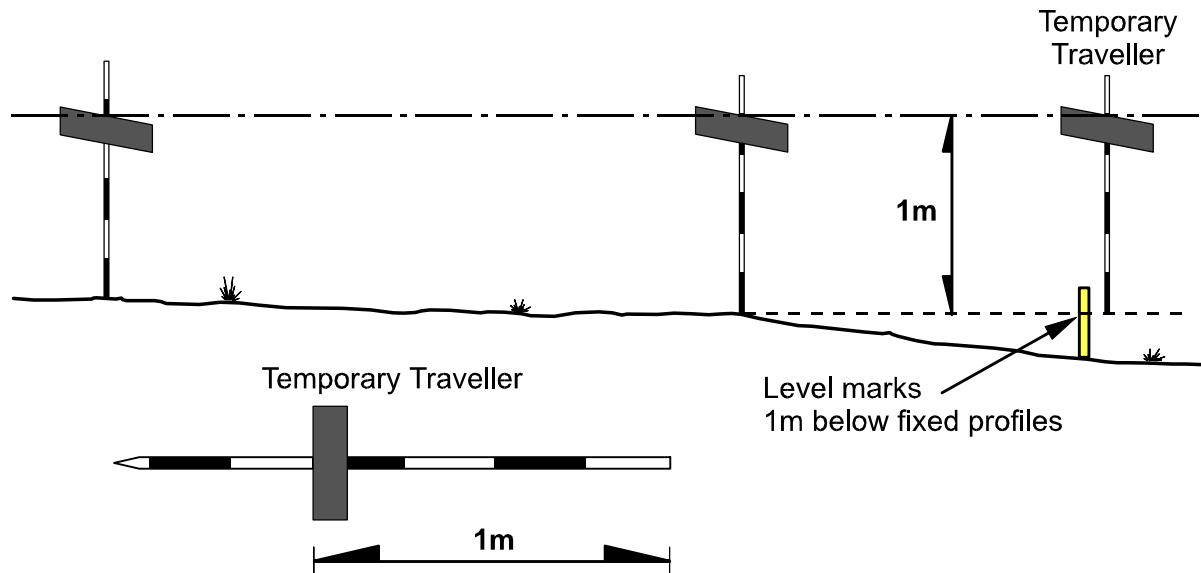

The temporary traveller is easily made on site by measuring the length needed from the blunt end of a ranging rod to the further edge of the profile, which is then clamped in position. The temporary traveller is then ready for use.

When used with fixed set out profiles, the traveller will give an indication of the finished construction levels anywhere along the sight line of the set out profiles.

This is very useful for the site supervisor when setting out. The most frequent use the supervisor will make of temporary travellers, will be to mark earthwork levels on the edge of road pegs. But there are other uses for these travellers:

- ✓ to guide and check excavation below earthwork levels (eg. for excavation for drift base construction),
- ✓ to find out whether large boulders are above or below road levels before they are finally decided upon,
- ✓ to estimate the amount of fill needed if the road is "lifted" or crosses low areas - this will help estimate the work involved and help decide on the best road levels,
- ✓ to locate the end of drains and approaches, and
- ✓ to provide a quick check on work, levels, string lines etc.

However, for guiding drainage work the labourers and gang leaders should use the specially built travellers. This is because the profile on a temporary traveller can become loose and the supervisor may not be present to check and re-set the traveller length.

## The Use of Profile Boards

When we set out work with profile boards and use a string line level to control the level of the board, there are a number of uses we can make of them:

- (i) We can transfer a level from one side drain to the other side drain and thereby ensure that both sides drains are built to the same level of depth.
- (ii) We can set out a slope at the gradient we want. This is especially important for drains, the camber and drift approaches.
- (iii) We can check for low spots in the terrain, when setting out the road alignment.
- (iv) We can set out vertical curves.
- (v) We can estimate how much cutting and filling is involved, before we start construction works.
- (vi) We can find out the length of a mitre drain or outlet drain before we start works.
- (vii) We can find the length of a drift approach before we start works.

These uses give us good control over construction works, ensuring that the road is built the way we want it and to a uniform and good quality standard.

Finally, it makes it possible to coordinate a large number of workers so that each one's work will fit in with everybody else's work.

## Side Drains

The example below show how a side drain can be dug using profile boards to guarantee a straight and even slope even though the depth of the dig will vary along its length.

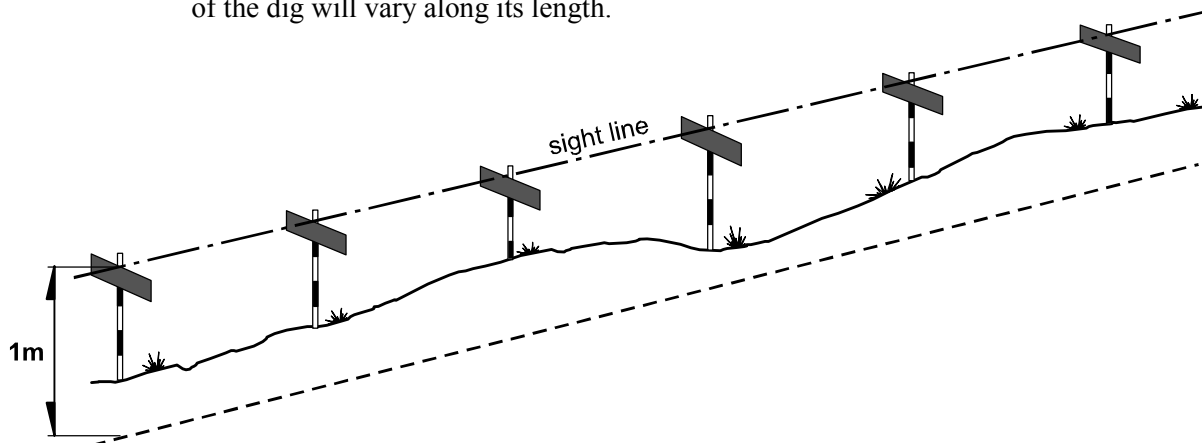

## Vertical Curves

The figure below shows how a vertical curve can be set out over a hill or across a dip in the terrain. The profile boards are set out to give a standard depth of dig to the drain and then adjusted by eye to give a smooth curve.

The spacing of 20m between the profile boards is enough to make a series of straight lines appear as a curve when the road is finished.

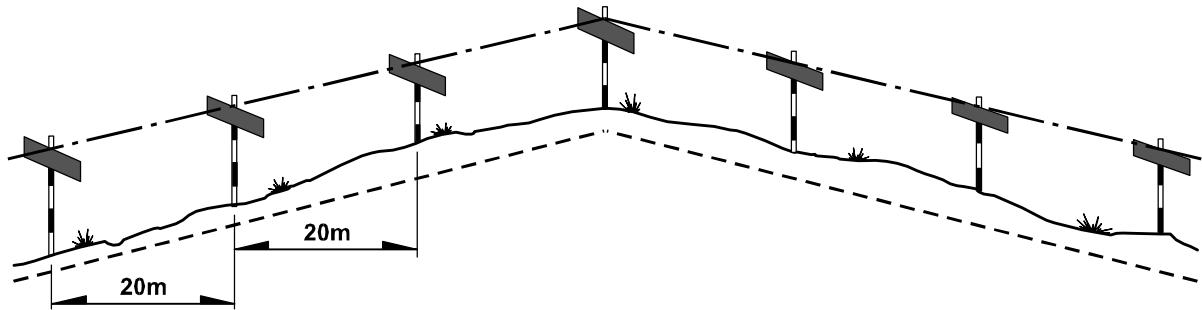

### Cross Sections

The following example shows how the profile boards indicate that no ditch is required on the low side of the road and how much filling is needed to produce the camber. Profile boards also enable us to set out the correct level at the shoulders of the road.

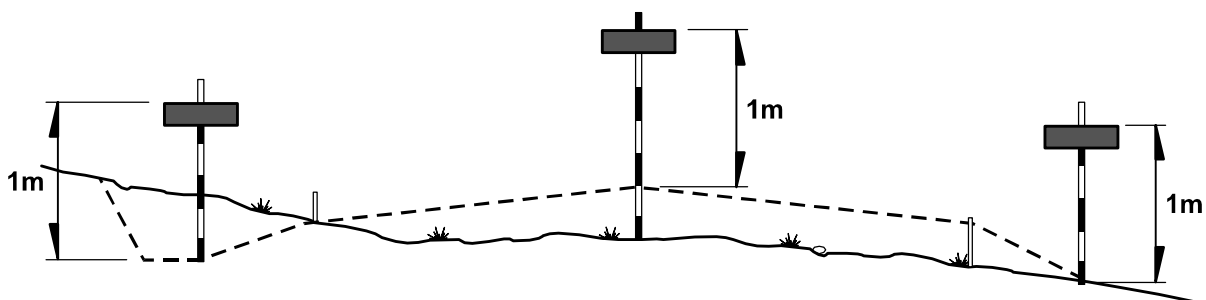

### Slopes

We can set out a gradient or slope by using profile boards. For example, if we transfer the level of one profile to the ranging rod 15 m away and set the profile board 0.75 m above this mark. The two boards are then set at a slope of 5%.

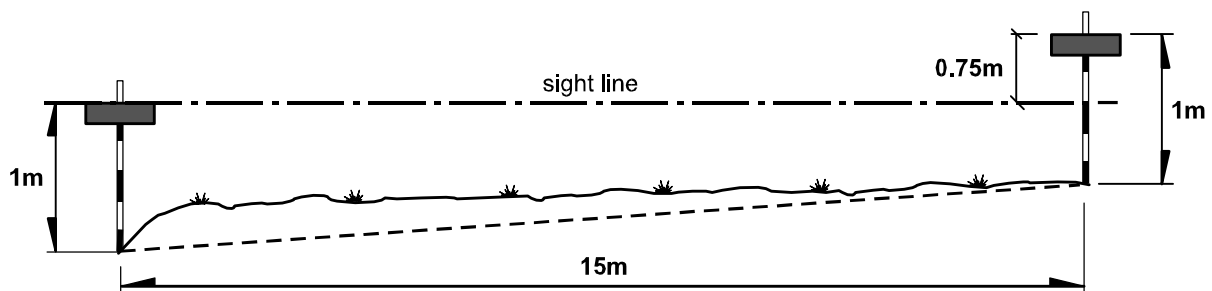

It is possible to use profile boards in this way to make sure that mitre drains are dug at not less than the minimum allowable slope.

The difference in level is calculated as follows:

A 5% slope means that there is a 5 metre difference in level over a distance of 100 metres.

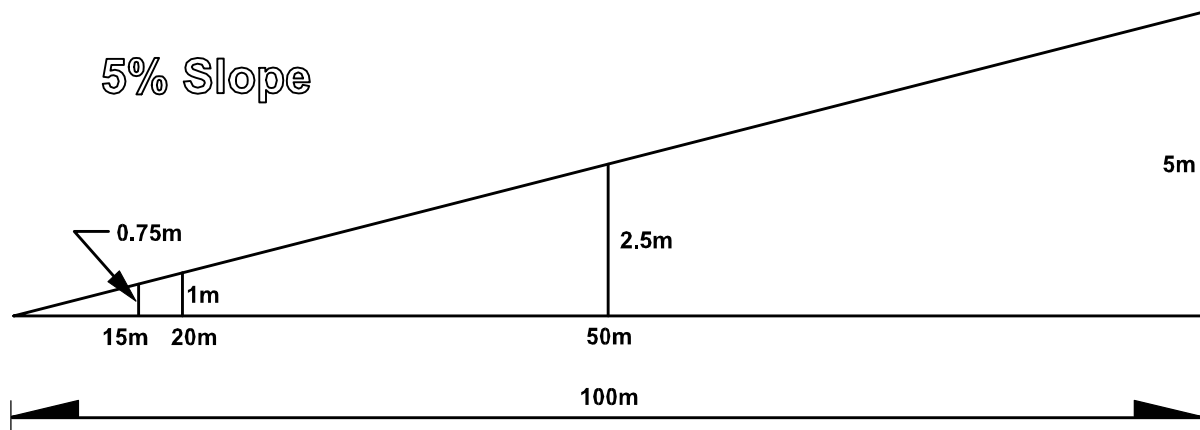

To find the difference in level over a short distance, multiply your measured distance by 5m and divide by 100m. For example:

$$15m \times \frac{5}{100} = 0.75m \text{ (75cm)}$$

As a result, we can set out any gradient we wish.

For mitre drains, the least slope that is allowed is 1:125.

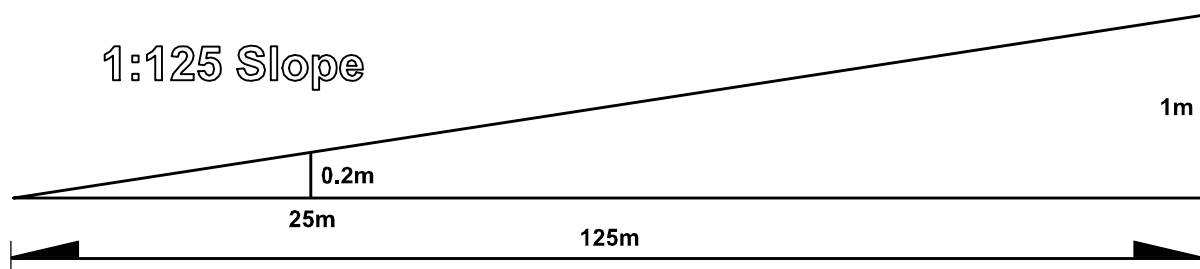

If we select a convenient distance between the profile boards (say 25m), we calculate the difference in level of the mitre drain profiles as

$$25m \times \frac{1}{125} = 0.20m \text{ (20cm)}$$

## Length of a Mitre Drain

Another use is to establish the length of a mitre drain before starting work. After setting the slope profile boards to the right gradient, we can use the traveller to see how far we have to go to get the three profiles to line up. The position where the traveller rests on the ground and lines up with the two fixed profile boards show where no excavation is needed and is therefore the end of the drain.

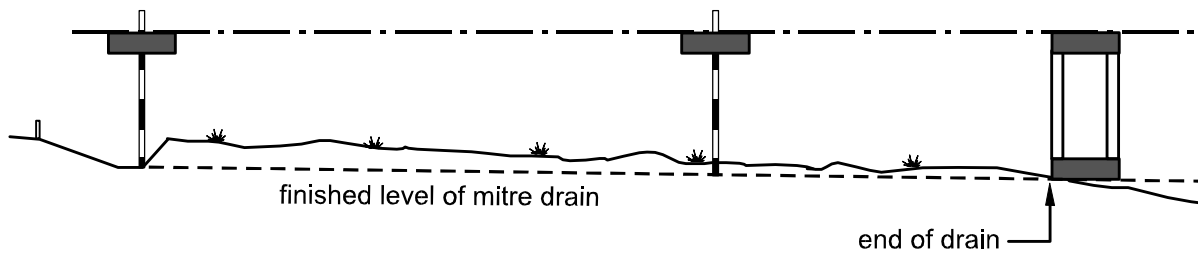

Finally, it should also be mentioned that the Profile Board Method is effective to use when setting out works for gravelling, drifts and culverts. This is described in detail in the following chapters.

## 1.3 The Centre Line

### Road Alignment

Selecting the centre line off the road is the most important duty of the Site Supervisor. If the wrong alignment is chosen, it can result in delays to construction works, over-use of workdays and a road that is difficult and expensive to maintain.

The centre line should be selected to avoid areas of bad or difficult drainage, areas of bad soil or large earthworks, areas of rock outcrops or heavy bush clearing. In addition, where drainage structures are needed, the centre line should be selected so that the structures are located at the best crossing point.

#### Check List

- ✓ Locate the best sites for river crossings.
- ✓ Avoid rocky areas.
- ✓ Avoid areas with heavy bush-clearing.
- ✓ Try to avoid complicated drainage solutions.
- ✓ Try to follow existing alignments of roads and tracks.
- ✓ Avoid steep gradients (maximum 10%).
- ✓ Keep earth-moving at a minimum.
- ✓ Be considerate with existing farming activities in the area.
- ✓ Avoid triggering soil erosion.

Good selection of the centre line is the best way to save workdays - try to avoid areas that will consume a lot of workdays overcoming natural obstacles.

The centre line selected is a compromise between a number of problems and you will have to work out how you would solve each of these problems, and the amount of work involved. For example, you could avoid an expensive structure by means of a longer route that went round the water course. You would have to consider the cost of the structure against the cost of the extra road works.

Take plenty of time to inspect the route and find the best alignment. This means walking along the route, trying a number of alternatives and working out how it will be possible to tackle the problems.

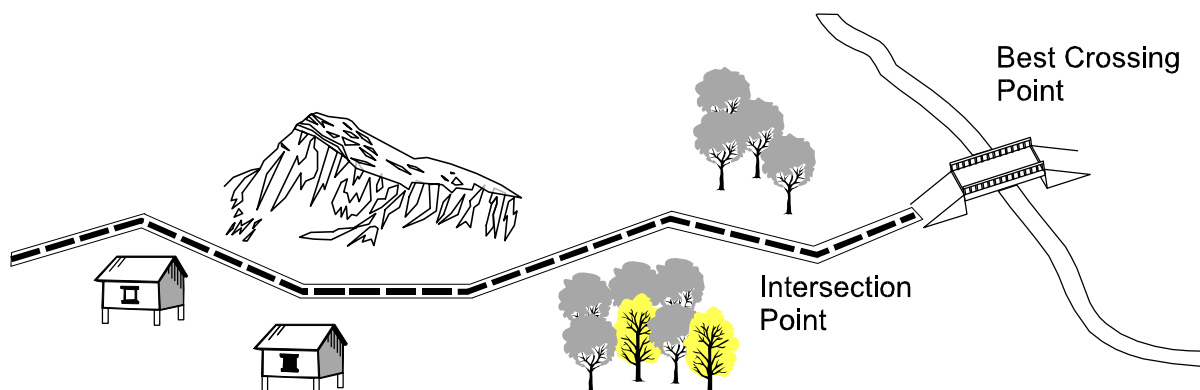



### Remember:

Whatever solution you choose, you must make sure that the road will be safe and that the solution will work. You must choose the most economical route, but you must not try to "save" workdays by not properly overcoming, or by ignoring, problems. Do not build road sections that will be likely to be damaged in the future and will cause maintenance problems.

If the right solution is too expensive during construction, it will certainly be too expensive to solve using limited maintenance funds.

The centre line is first selected by means of a series of straight lines. These lines link together at points of intersection. The intersection points are located with the use of ranging rods, and are properly marked by pegs. Once the intersection points are fixed, check with the local landowners to see if there is any objection to the proposed lines.

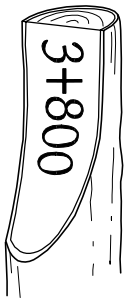

Pegs are used to mark the alignment and the levels of the road. They are made of wood and can normally be made on site. They should have a length of approximately 40cm. The chainage of the road is marked onto the peg with a water proof marker. Before construction works starts, reference pegs are placed outside the road formation. Ensure that these pegs are hammered deep into the ground so that it will be difficult to remove them.

### Setting Out Straight Lines

Straight lines are set out by marking points every 50m to 100m with ranging rods. Between these ranging rods, intermediate points are set out at every 10m. Normally, sections of not more than 50 to 100m are set out at the time. In mountainous terrain, sections of less than 50m may be chosen.

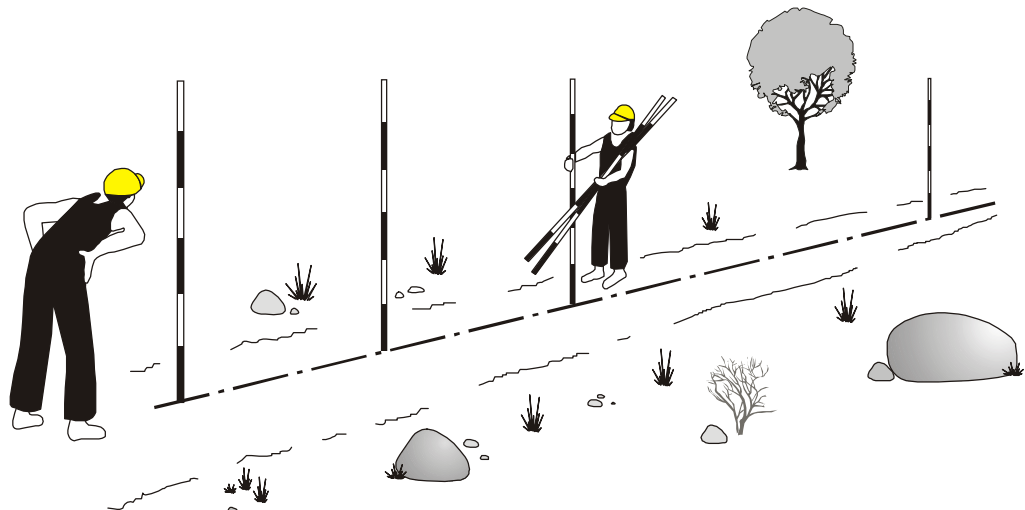

### Setting Out Curves

Your centre line has now been selected by means of a series of straight lines meeting at points of intersection. Eventually, these straights will be joined by curves that will be set out during the detailed setting out.

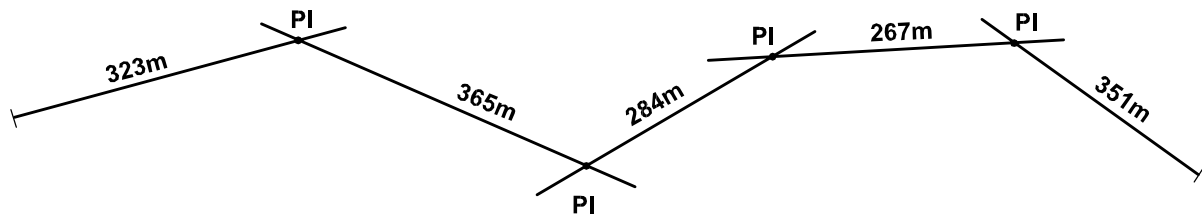

Measure the distance between the intersection points and keep this as a first estimate of the length of the road to be constructed.

### The Intersection Method

The intersection method is a simple and effective method to set out curves. It requires simple equipment and can be easily understood by the foremen.

- Step 1:** First place a peg at the point where the two straight lines meet (intersection point PI). Then locate the *tangent points*, TP. The first tangent point is where your curve begins, and the second where it ends. Divide the tangent lines in equal lengths, by setting out a number of ranging rods along the tangent lines at say 5m intervals.

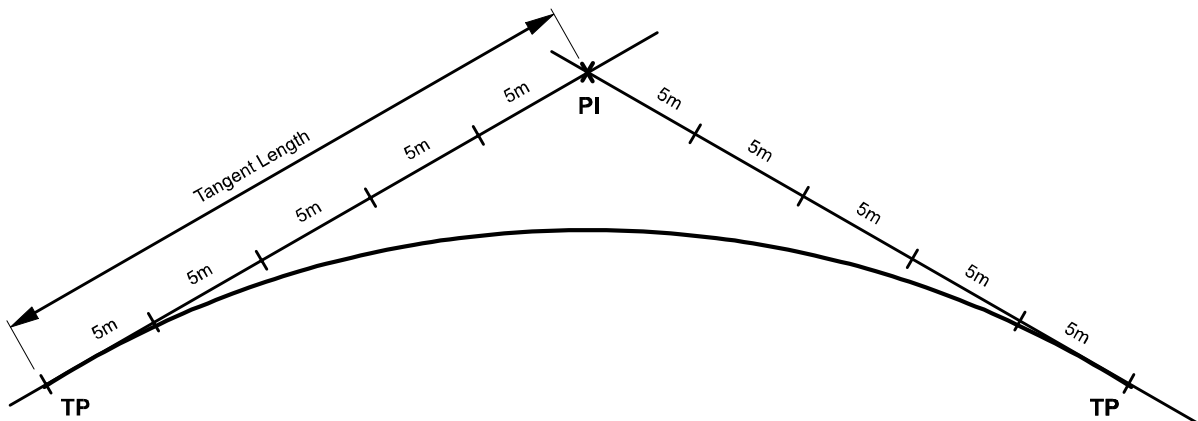

With longer tangents, you will achieve a longer curve with a larger radius. Deciding the length of the tangents is best done by experience. You will gain experience in how to select the best tangent length. First look at the intersection angle between the two tangents:

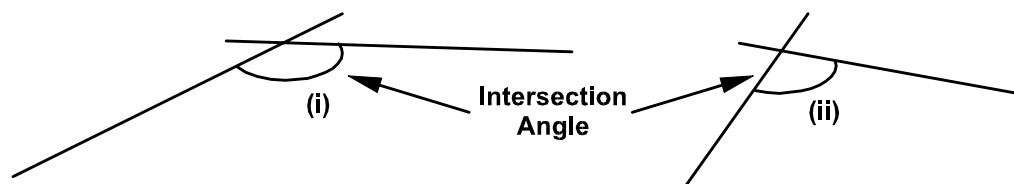

A large intersection angle (i) will produce an easy curve with a big radius. The tangent length can then be short (however, not shorter than 20m).

A smaller intersection angle will give a sharper curve with a short radius. In such situations, the tangent lines should be made longer (30, 40, 50 or 60m) to increase the radius of the curve.

Sometimes, you will want to adjust the tangent length to control where the centre line of the curve goes (see below: Adjusting the Position of the Curve).

**Step 2:** Give each ranging rod a letter as shown in the figure below. Sight along line a - a with an assistant holding a ranging rod in your sight line. A second assistant stands at point b and sights along the line b - b. Move your assistant along line a - a until he also stands on line b - b. Mark this spot with a ranging rod and a peg. This is your first point defining the curve.

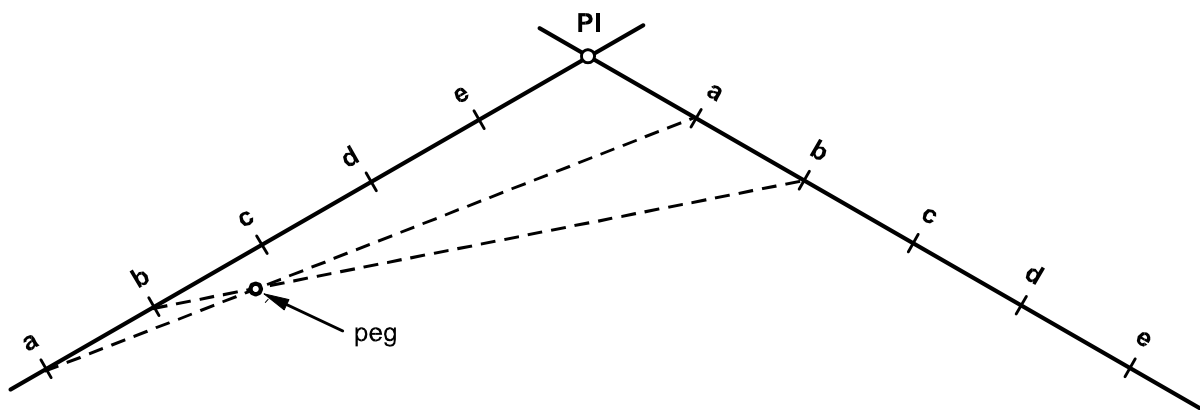

Now repeat this exercise by sighting along b - b while an assistant is sighting along c - c to find your next curve point.

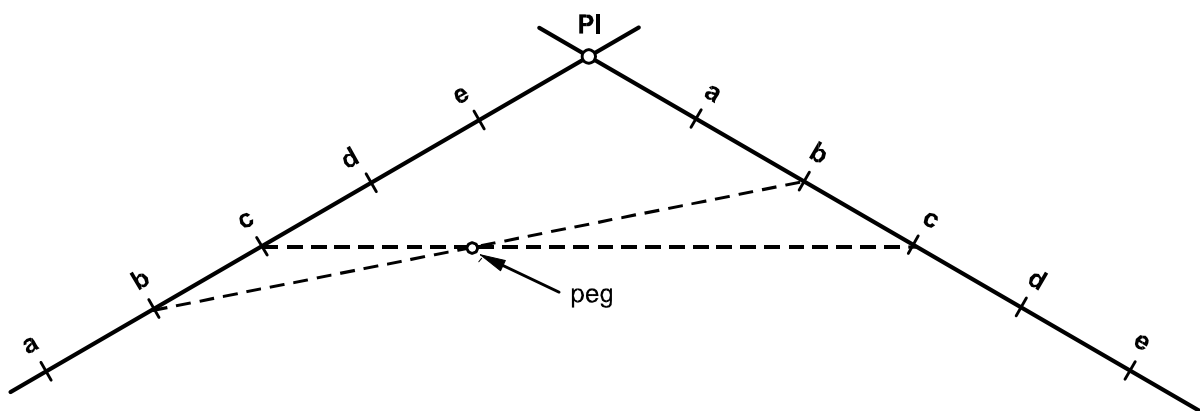

Complete the exercise for line c - c, d - d, etc. Finally, use these curve points to set out intermediate points along the curve at 5 m intervals. Inspect the curve and make sure that all the points provide a smooth curve.

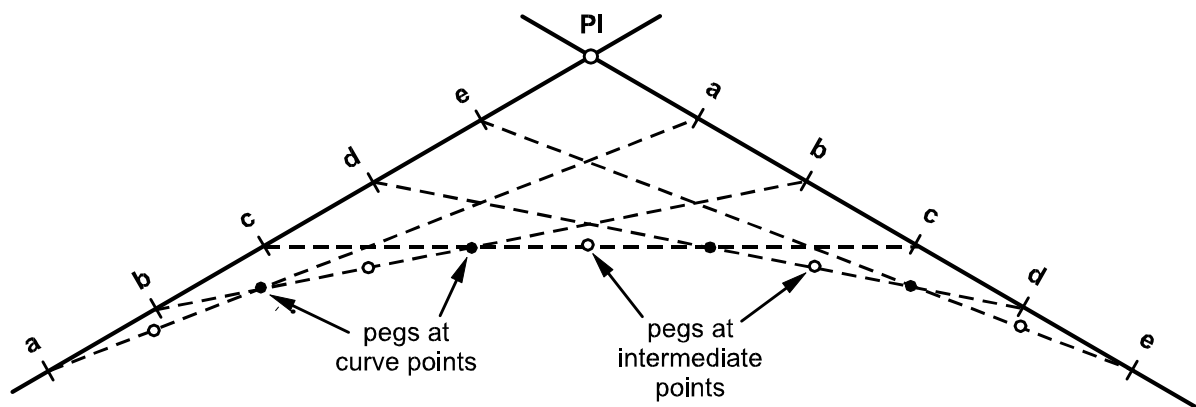

### Adjusting the Position of the Curve

You always get one curve point less than the number of ranging rods on the tangent length. For example, 5 ranging rods will give you 4 curve points (as above).

Even numbers of ranging rods gives uneven numbers of curve points, then the middle curve point will be opposite the intersection point, PI. Where the middle two lines intersect is the middle point of the curve (as below with 3-3 & 4-4 and 2-2 & 3-3).

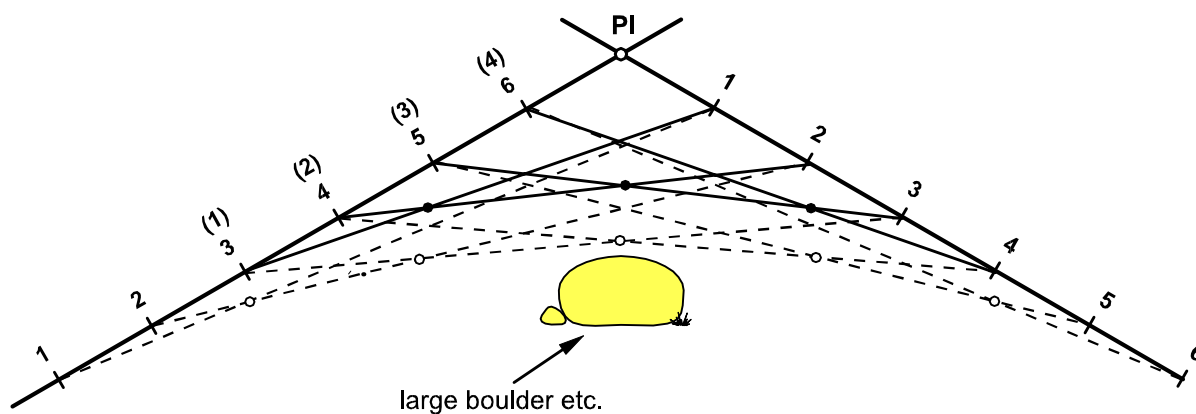

If we increase the length of the tangent lines, we find that the curve moves further away from PI. We can use this when we need to set out the centre line of the curve to avoid obstacles such as trees, buildings, boulders, etc.

## Setting out Curves "by Eye"

When setting out a curve it is necessary to adjust pegs "by eye" until they appear to follow a smooth curve.

This is a useful skill that has to be learned by every supervisor and technician.

A quick way to control and adjust the setting out of the curve is to line up the first and third peg and measure the off-set of the second peg to this line. Then repeat this exercise by lining up the second and fourth pegs and measuring the off-set to the third peg to this line. Walk around the curve and check and adjust these off-sets until you are satisfied that they are nearly equal.

This will give you a good enough curve to set out the dimensions necessary to build the road.

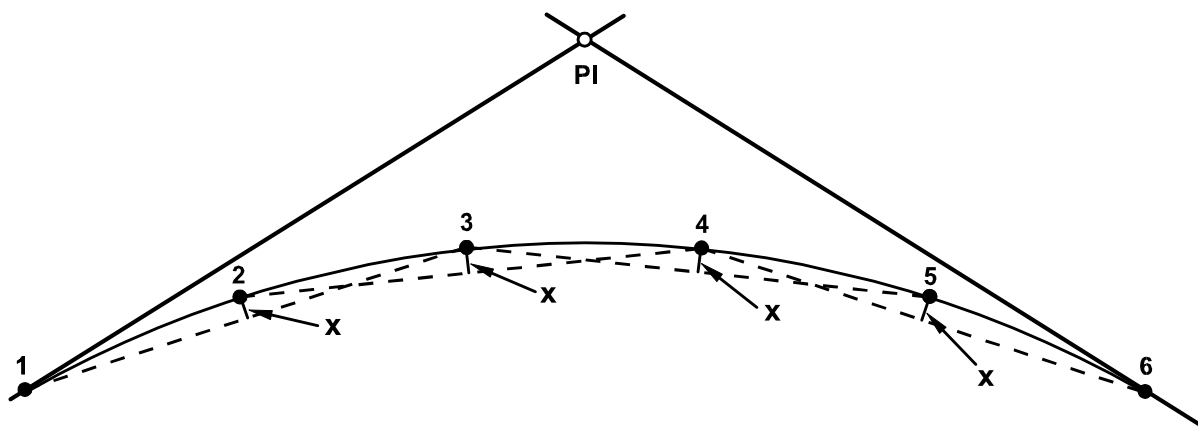

When the radius of a curve is large (when the angle between the straights is large), it is more practical to set the curve out "by eye" directly rather than by the intersection method. This should only be done on large radius curves with short curved lengths. When the intersection angle is small and the radius small, you should always use the intersection method.

This method may also prove useful in mountainous terrain where there is limited space for using the intersection method.

## Off-set Pegs

Once the centre line has been set out, it is necessary to mark the line in a proper way. This is carried out by setting out solid off-set pegs 90 degrees to the side of the pegs indicating your centre line.

In case the road needs to be constructed on an embankment, off-set pegs should be placed on each side at the foot of the planned embankment, at 10m intervals along the road line.

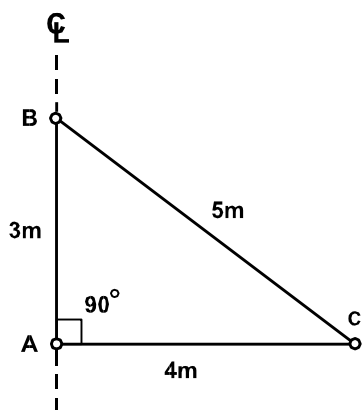

To set out the off-set pegs, you must first construct a 90E angle from the centre line. This can be done by using the 30m tape. Measure 3m from the first ranging rod (A) along the centre line and place a temporary peg at this position (B). Then find the 8m mark on your tape (C) while holding the tape at the 12m mark at point (A). A ranging rod is then positioned at the 8m mark on the tape, creating a line between A and C, 90E to the centre line. Repeat this exercise on the opposite side of the centre line and check that the three ranging rods are on line. You can now measure out the position of the off-set pegs by sighting along the three ranging rods.

Alternatively, it is possible to manufacture a template which can be used for setting out 90 degree angles.

### Vertical Alignment

When the horizontal road alignment has been established, the next step is to set out the *vertical alignment*. Vertical alignment sets out the level of the road in relation to the surrounding terrain. The method shown below is based on the use of profile boards to optimise the road level, avoiding unnecessary earth movement.

**Step 1:** First, fix profile boards on the ranging rods along the centre line at a fixed level, say 1 metre above the ground level.

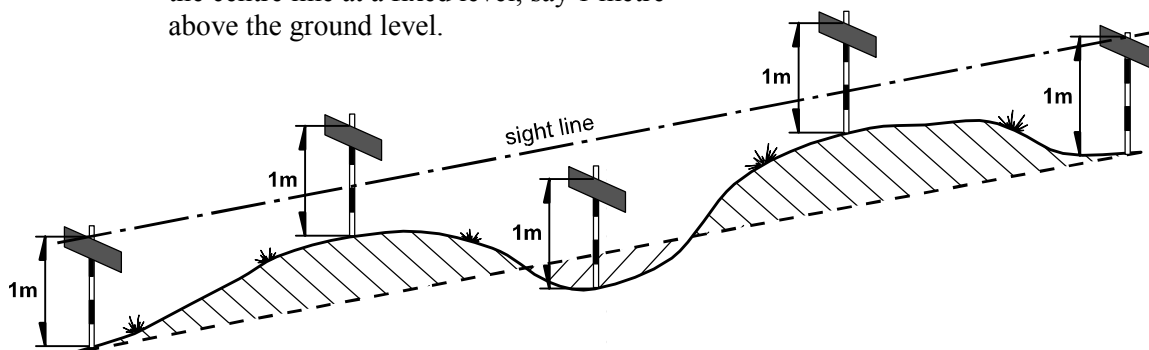

**Step 2:** Then sight along the profile boards. Get your assistant to adjust the level of each of the intermediate profile boards so they are all on line with the first and the last profile. All the profile boards will then be at a level 1 metre above the level of the centre line of the new road (before designing the camber).

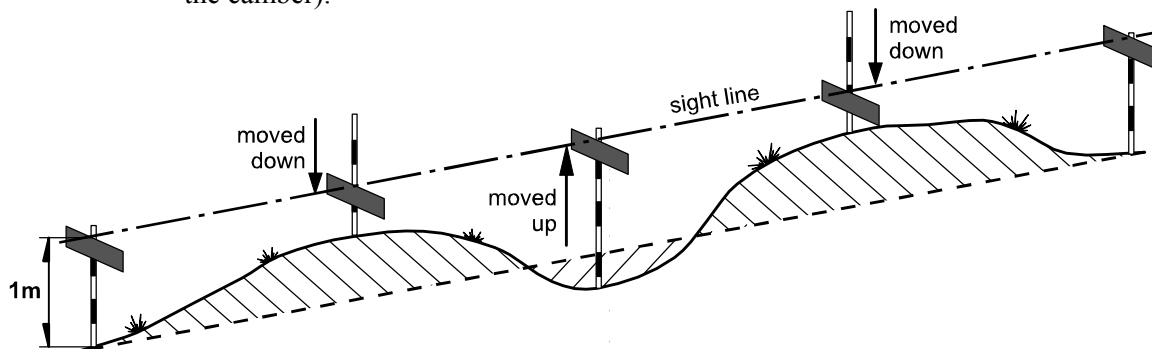

**Step 3:** If the level of the centre line is too deep into the terrain, i.e. involving too much excavation works, you can move the profile boards up or down to reduce the levelling works, achieving a balance between the volumes of excavation and fill.

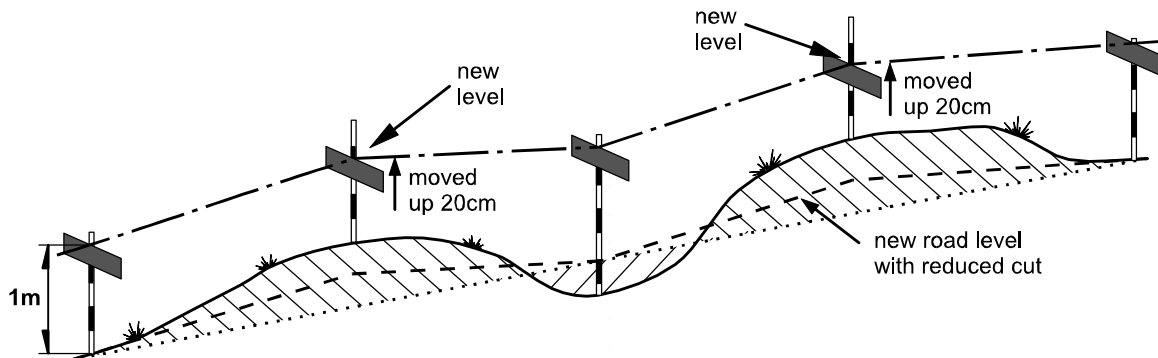

Finally, make sure that the profile boards along the centre line has been correctly placed. All other levels for the road structure will be set out based on the profiles along the centre line.

### Road Gradients

When setting out the centre line of a road, it is important to check the gradients along the road profiles. Transfer the level of one profile board to the next ranging rod and

$$\text{Slope of road} = \frac{\text{level difference}}{\text{length}} \times 100 = \% \text{ slope}$$

measure the difference. The slope or the gradient is then calculated as follows:

So, if the difference of levels is measured to 0.5m between two profile boards with a length of 20m between them, the gradient is calculated to:

$$\frac{0.50}{20} \times 100 = 2.5 \%$$

This procedure is very useful in order to find low spots along the road line and to check that the slope of the side drains will not cause erosion or silting. If the road gradient is found to be unsuitable, the road levels can and should be changed before construction works start.

It is also useful, when selecting the road centre line, to check that the slope of the existing terrain to make sure it is not too steep or too flat before fixing the location of the centre line.

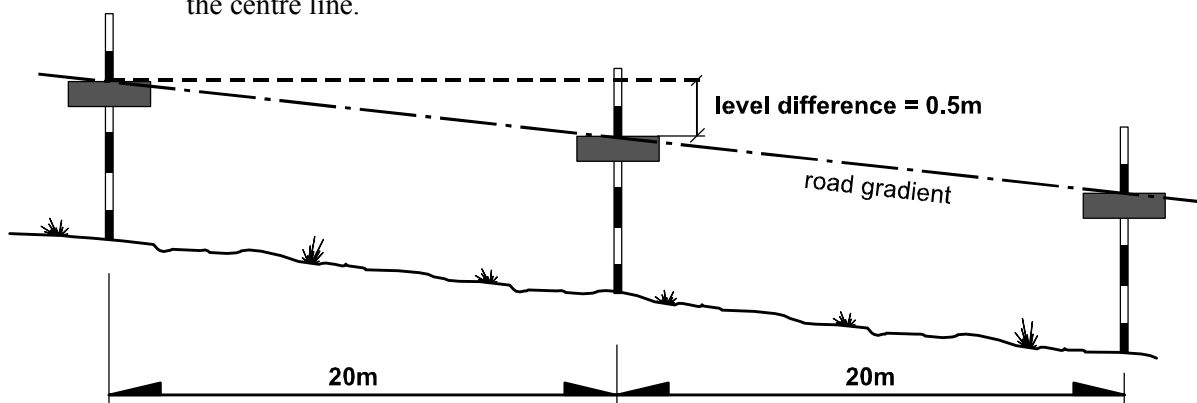

This is done by setting a profile 1m above the ground at the start of the section in question, and another 1m above the ground on the proposed centre line at the end of the section. A third profile is set 10m from the first profile along the line from the other two. Using a line level, the difference in level between the two profiles 10m apart is measured and the percentage slope of the terrain can be calculated.

$$\text{slope} = \frac{\text{level difference}}{10} \times 100 \%$$

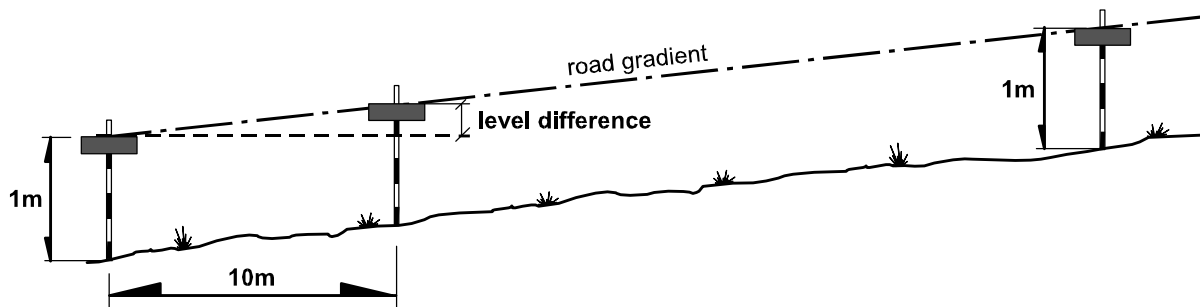

This way, the gradient can be checked before the centre line is fixed, avoiding unsuitable gradients. Try different centre line locations to select the best possible gradient for the road.



# **Chapter 2**

# **Construction Procedures**

---



# Chapter 2

## Construction Procedures

<b>2.1</b>	<b>Clearing</b>	26
	Bush Clearing	26
	Boulder Removal	26
	Topsoil Removal	27
	Reporting	27
<b>2.2</b>	<b>Earthworks</b>	28
	Cut to Level	28
	The Fill Side	34
	Camber and Side Drain Construction	35
	Super-elevation	36
	Reporting	37
<b>2.3</b>	<b>Embankment Construction</b>	38
	Earthwork Volume Calculations	38
	Site Level Planning and Work Force Organisation	42
<b>2.4</b>	<b>Ditching, Sloping and Camber Formation</b>	44
<b>2.5</b>	<b>Off-road Drainage</b>	48
	Mitre Drains	48
	Angle of Mitre Drains	50
	Scour Checks	51
	Cut-off Drains	52
<b>2.6</b>	<b>Compaction</b>	53
	Optimal Moisture Content	53
	Compaction Methods	53
	Quality Standards	55
	Compaction Procedure	55
<b>2.7</b>	<b>Culverts</b>	56
<b>2.8</b>	<b>Drifts</b>	59
<b>2.9</b>	<b>Gravelling</b>	63
	Standards	63
	Gravel Source	63
	Gravel Quality	64
	Water	64
	Work Plan	65
	Work Procedure	65
	Control of Works	67
	Reporting	67
<b>2.10</b>	<b>Erosion Protection</b>	68

## 2 Construction Procedures

### 2.1 Clearing

#### Bush Clearing

**H**heavy bush clearing involves cutting down and removing trees, the clearing of dense bush and scrub and the digging up and removing root systems to prevent regrowth.

Heavy bush clearing and the unnecessary cutting down of trees should be avoided wherever possible by careful selection of the centre line.

Work should be organised on a task work basis, allocating work by the area or by specific job task (such as the removal of one or two large trees), depending on the type and difficulty of the work.

Before felling a tree, make sure it is absolutely necessary to cut it down. Maybe, it is possible to adjust the alignment so that the tree felling can be avoided. If a tree needs to be cut, use experienced workers and keep everyone else well away. After felling, cut the tree in pieces and remove them from the road side. Once the tree is cut, dig up and remove the roots. Holes after root extraction needs to be filled and compacted properly using hand rammers.

Heavy grass cover should be cleared. Light grass cover can be incorporated in the construction earthworks without too much of a problem, and afterwards regrows, forming protection against erosion on the shoulders. Heavy grass tufts can be used to line side slopes in cross cut conditions or on embankments, and should be separated from the soil to be used for road construction.

This work is carried out by task work per area, and the area set will depend on the difficulty of the work.

#### Boulder Removal

Boulder removal can involve hand carrying small boulders, rolling clear, breaking or digging and burying large boulders. This work is often time consuming and expensive and should be avoided if possible when selecting the alignment. Where there is excessive boulders in the soil, which creates problems for drain excavation, the possibility of lifting the road levels should be considered.



Task work on a group or specific job basis should be used to organise the labour force.

### Topsoil Removal

Topsoil removal is usually only needed where the topsoil is deep (10-15cm), very organic and obviously much lower in strength than the soil below. Unnecessary topsoil removal has very little effect on the strength of the road. Topsoil removal is most likely to be needed in river valleys and flood areas that build up silt. Most agricultural land and open areas are eroded, with a very thin topsoil layer which can be mixed in with the earthworks for the road construction.

Topsoil removal is executed using task work on an area basis, the area being determined by the thickness of the topsoil.

### Reporting

Clearing works can be reported under a single cover-all activity, or by individual activities covering heavy bush, heavy grass cover, boulders and topsoil removal. The project management will decide on the reporting procedures depending on the scale of the clearing works. Unless there is extensive work expected under the individual activities, there is little advantage to be gained from over-detailed reporting. Usually, a cover-all clearing activity will give sufficient management control.

## 2.2 Earthworks

**B**asically, road construction earthworks involves digging drains and using the material to build up the camber, excavating cut to fill to form the road and building up the road on embankments in flat areas with poor drainage.

Let us first consider the situation where the road is built on land that is level, or nearly level, between drains - that is, with very little cross slope.

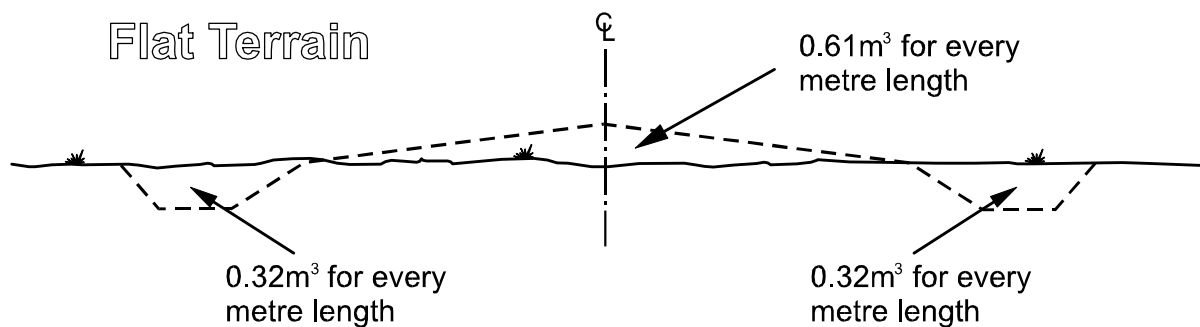

The earthworks is then simply to excavate the side drains and use this material to form the camber. You will see that the material from the side drains is slightly more than what is needed to form the camber. This is good, as usually more material is needed than indicated, either because of low spots in the ground or because of unsuitable soil or because the land is never consistently level.

### Cut to Level

The problems start when the road is built on cross sloping ground. The steeper the cross slope, the more excavation is needed to build the road. Always avoid steep cross slopes where possible. Locate the road on ridges where possible - this will reduce earthworks as well as reducing drainage works.

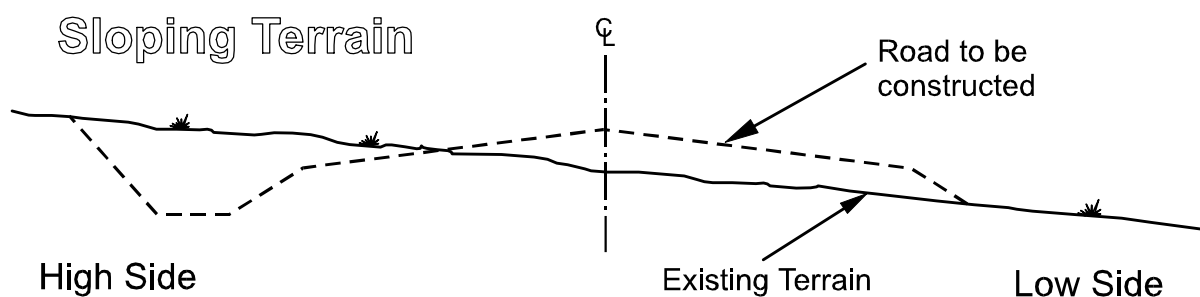

Road construction in cross sloping terrain have the following features:

- the high side drain will have to be dug deep,
- the low side drain is normally not needed, and
- the road will have to be built on a fill on the low side.

The best way to do this is to split the work into two separate stages.

**Stage 1** Excavate the high side and build up the low side and form the side slope on the low side.

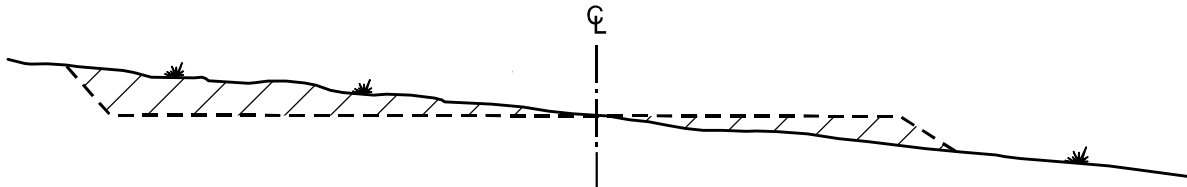

**Stage 2** Excavate the high side drain and form the camber.

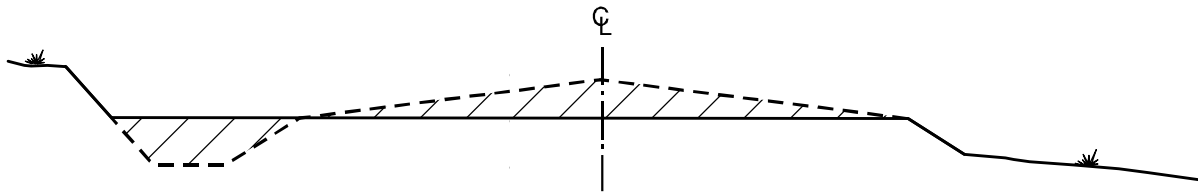

The advantages of this method of working in stages are:

- the excavation approximately balances the amount of fill needed,
- the fill material can be obtained as close as possible to where it is needed - reducing the need for longitudinal haulage,
- by levelling the formation only as far as the edge of the road and then sloping down to the natural ground, reduce the excavation and, in most cases avoid the need for a side drain on the low side.

The excavation and fill are balanced each side of the centre line, but the width of the excavation has to give sufficient room for the side drain to be dug. This fixes the setting out dimensions for excavation on the high side.

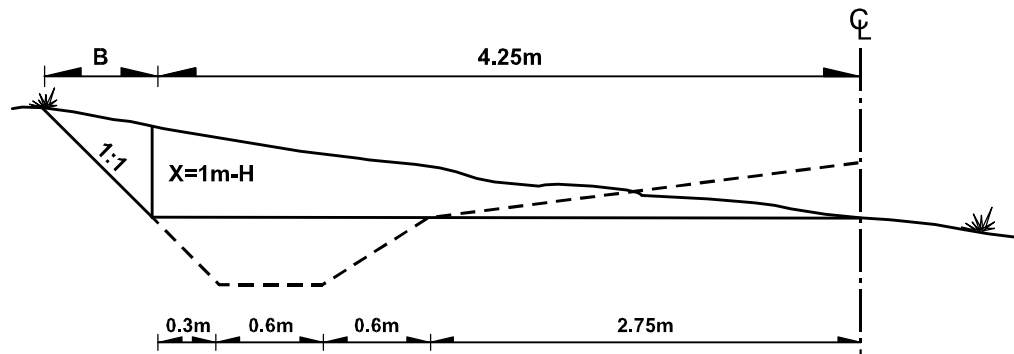

As indicated in the figure above, it is necessary to level to 4.25m back from the centre line to provide enough room to dig and back slope the side drain. The width of the back slope to the excavation should be sufficient to achieve a slope of 1:1, similar to the back slope of the side drain.

On steeper cross slopes, there is too much excavation for a practically sized gang to finish in one day. In these cases, the excavation is divided into two or three days work. By calculating the volumes involved, we know that the following setting out dimensions will give roughly equal amounts of work for the days involved.

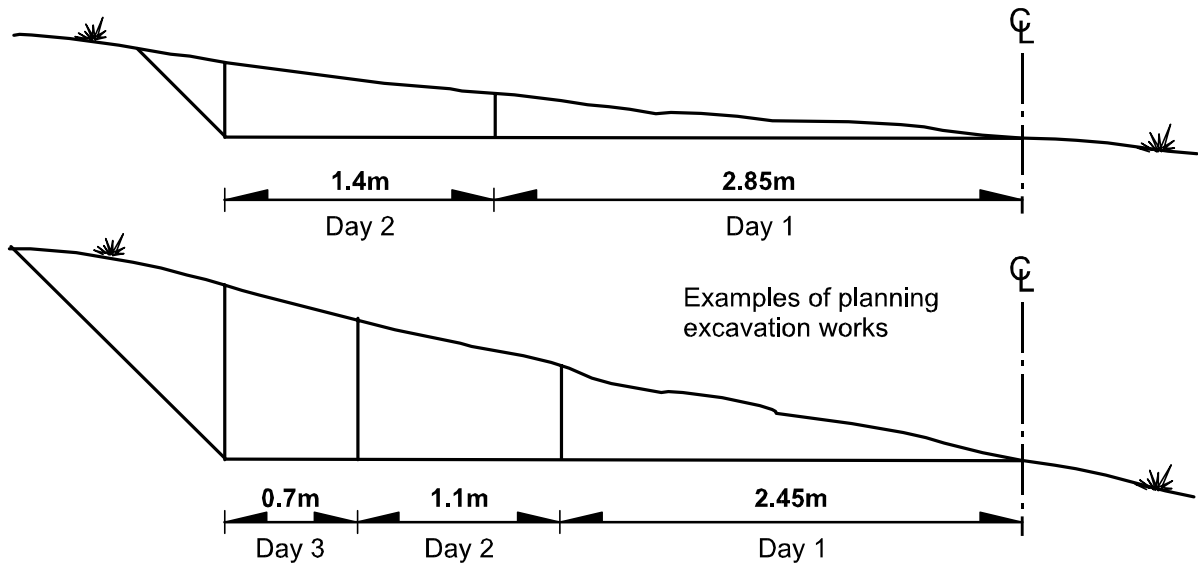

When the centre line profiles are set out at 1m above ground level, we can measure the height of the high side profile to tell us:

- ✓ how steep the slope is,
- ✓ how deep we will have to dig, and
- ✓ the volume we will have to dig.

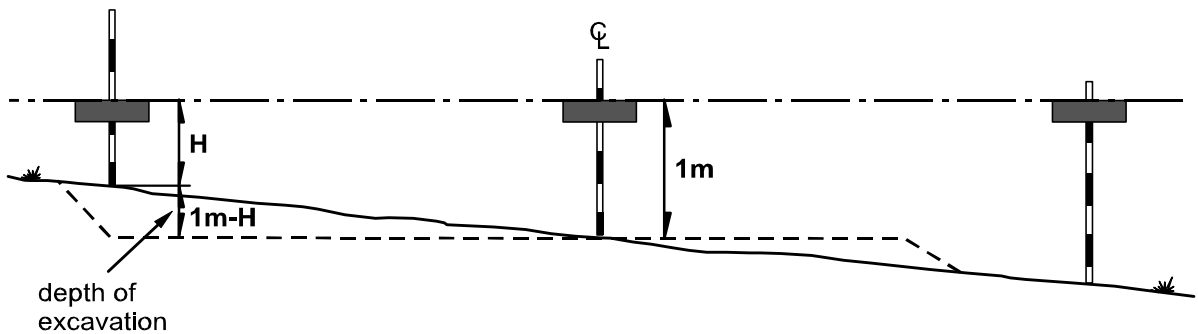

We can calculate the volumes to be excavated for the most common profile heights to be found in practice. These volumes can be given to the supervisor in table form and can be used to work out the workdays needed to carry out the excavation and are used to report the volume of completed works.

When there is little cross slope (the average height of the high side profile is 90 or 95cm), it is possible to dig the high side drain without levelling first. However, there are advantages in levelling in these conditions. Setting out the side drain is easier on a levelled surface and the side drain easier to build to the correct shape. The supervisor will usually level these minor cross slopes.

The setting out in these cases will be different as there is no advantage in levelling right through to the centre line. The levelling will be done from 2.75m to 4.25m, measured out from the centre line.

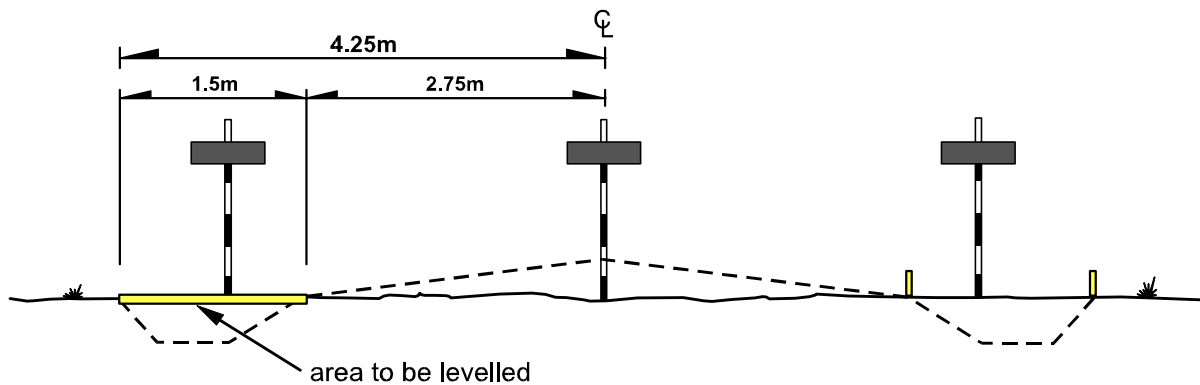

Please note that the above levelling practice only applies for new construction. When rehabilitating an existing road, levelling works should be kept to a minimum, leaving the existing road camber in place and only adding onto it where it has been worn down.

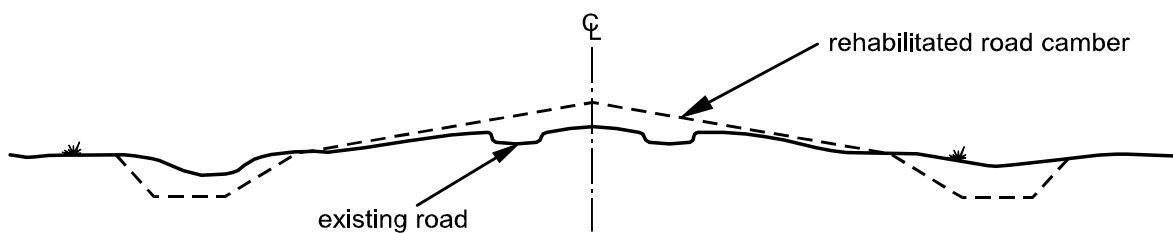

The slope of ground is not the same along the length of the road. To set out the work we have to find the average slope over a 20m section.

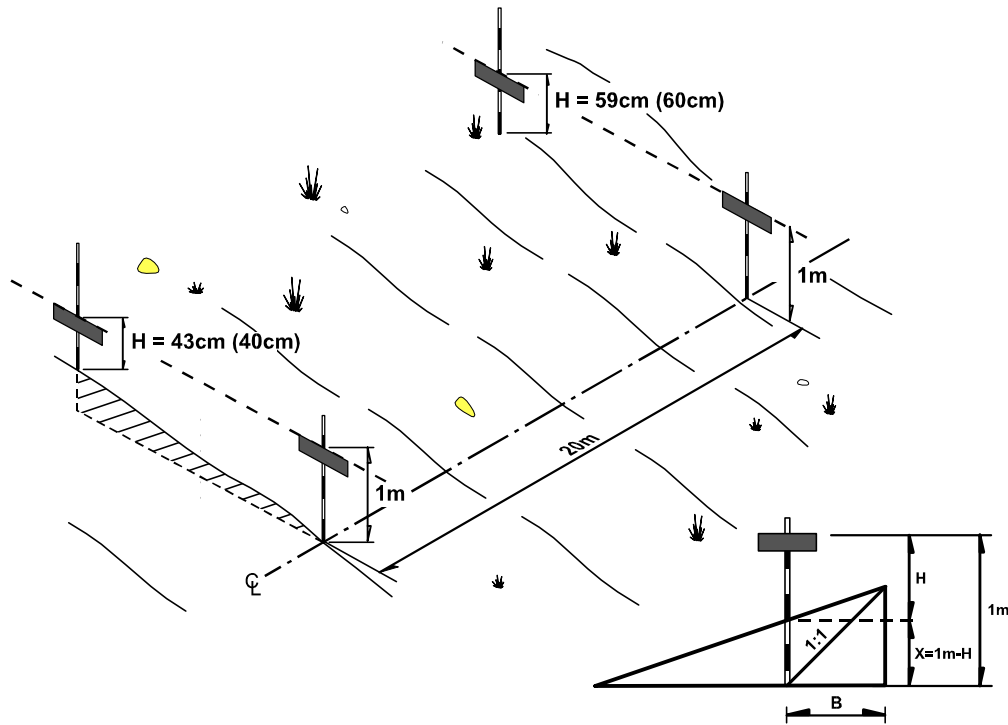

EXCAVATION VOLUMES FOR 20m

Profile Height, H [cm]	Depth of Cut, X [cm]	Back Slope B [cm]	Volumes [m <sup>3</sup> ]				
			Cut to Level	Back Slope	Total	Variation of Width <sup>1</sup>	
			-1.0m	+1.0m			
90	10	10	4.3	0.1	4.4	3.4	5.4
85	15	16	6.4	0.2	6.6	5.1	8.1
80	20	21	8.5	0.4	8.9	6.9	10.9
75	25	27	10.6	0.7	11.3	8.8	13.8
70	30	32	12.8	0.9	13.7	10.7	16.7
65	35	38	14.9	1.3	16.2	12.7	19.7
60	40	44	17.0	1.8	18.8	14.8	22.7
55	45	50	19.1	2.3	21.4	17.0	25.8
50	50	57	21.3	2.8	24.1	19.2	29.0
45	55	63	23.4	3.5	26.9	21.5	32.3
40	60	70	25.5	4.2	29.7	23.9	35.6
35	65	77	27.6	5.0	32.6	26.4	38.9
30	70	84	29.8	5.8	35.6	29.0	42.4
25	75	91	31.9	6.8	38.7	31.7	45.9
20	80	99	34.0	7.9	41.9	34.5	49.6
15	85	106	36.1	9.1	45.2	37.4	53.2
10	90	114	38.3	10.2	48.5	40.5	57.0
5	95	122	40.4	11.6	52.0	43.6	60.9
0	100	131	42.5	13.1	55.6	46.9	64.9

If the height of one high side profile is 43cm and the next high side profile is 59cm then the average profile height is:

$$\frac{59 + 43}{2} = 51\text{cm}$$

To make calculations easier, we measure the heights to the nearest 10cm. Then, we calculate the average as follows:

$$\frac{60 + 40}{2} = 50\text{cm}$$

Rounding off profile heights to the nearest 10cm is sensible because the ground is uneven, and over a number of calculations any slight difference are cancelled out and we get an accurate estimate of the work involved.

Once the average of the high side profiles is calculated, the volume of excavation needed can be estimated. In this example, we can read the volume against the 50cm average in the table, in this case 24.1m<sup>3</sup>.

- Notes: 1 including volume of back slope
- 2 The table above only applies for situations where the two centre profile heights are 1m above the existing terrain. For other situations where this is not the case, the volumes need to be calculated manually.

We can calculate the number of workdays needed by dividing by the task rate that has been found to be fair. In this example, if the task rate is  $2\text{m}^3$  per day, then the workdays required can be estimated as:

$$\frac{24.1}{2} = 12 \text{ workdays}$$

The supervisor will then decide how to organise the work. 12 labourers working on a 20m section may not be practical. He may decide to do the work over 2 or 3 days. If the work is done in 2 days, he would assign 6 labourers each day - this would make sure the work is done at nearly the standard production rate. He/she would round the workday totals down to the nearest whole number.

The excavation width for the first day is then set out. The widths of excavation are calculated so that the work involved is roughly the same each day. The width for the first days work will be 2.85m measured from the centre line. The remaining 1.4m will be excavated on the second day. In this way, the same number of labourers are used each day to excavate the task length of 20m.

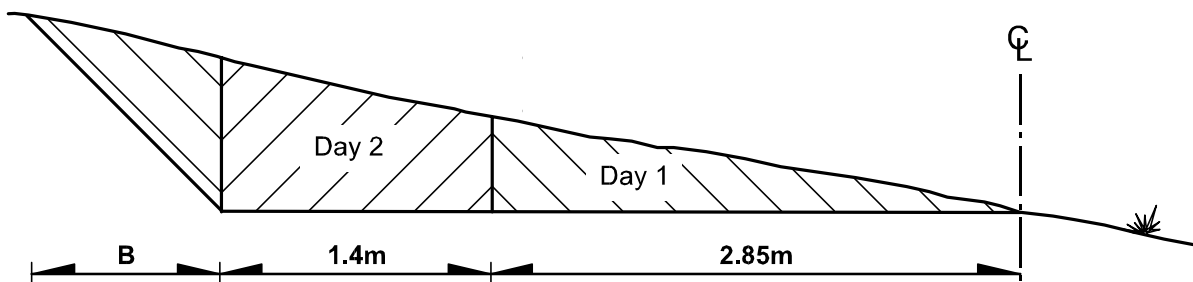

Once the excavation back to 4.25m has been completed, the supervisor has to decide whether it is necessary to extend the excavation back further to produce more material to form the fill and road camber.

If extra material is needed, he will set out a further width of 0.5 or 1.0m according to the amount of material needed. The volume table gives total volumes for extra excavation widths. The volume of excavation of the extra width is found by taking the volume for the standard width from the total extended volume. In this example, for an extra width of 0.5m it would be  $26.5\text{m}^3 - 24.1\text{m}^3 = 2.4\text{m}^3$ . From this, the supervisor would work out that he needs approximately one workday extra to do the work.

Once the excavation is finished, the levelled work is back sloped. The volume of the back sloping is included in the excavation totals to avoid difficult calculations on site by the supervisor when reporting completed works, but he also needs to assign labourers specifically for this task. The above table also shows the volume for the back slope. In the above mentioned example, the volume of the back slope is  $2.8\text{m}^3$  for which he would need to assign 1 labourer per 20m.

If the depth of excavation is 25cm or less, it is easier to include the back sloping in the drain back slope.

To ensure that the cut is fully excavated, use a traveller to control that the excavated ground is level.

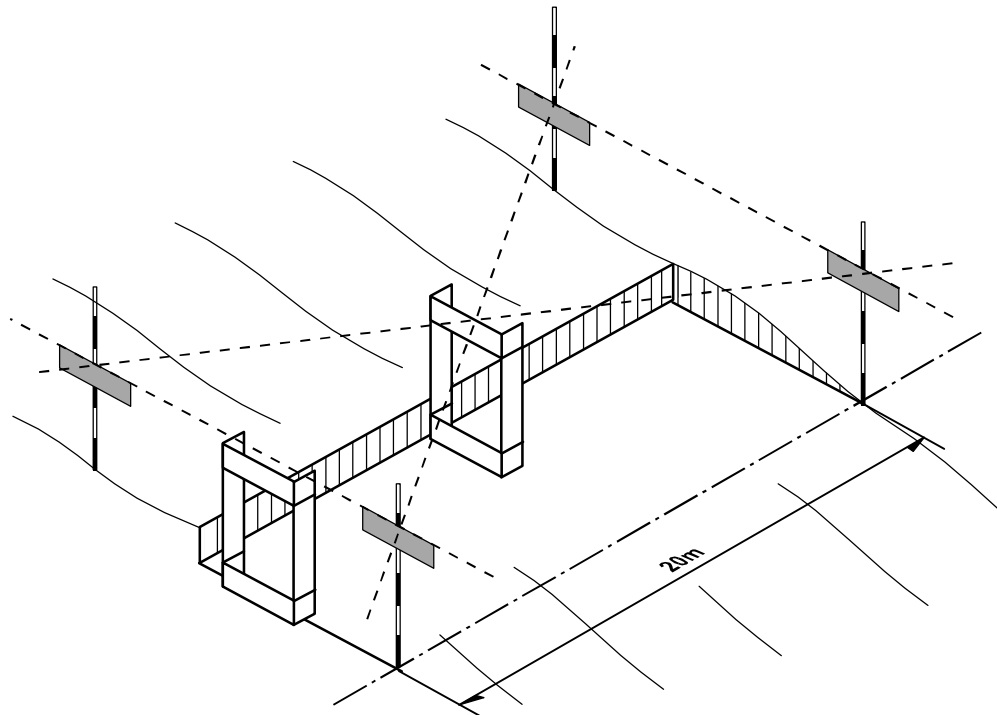

**The Fill Side**

It is also necessary to form the low side slope and level the formation. The number of labourers used to do this work can be estimated as roughly half the number of labourers doing the excavation. The actual number used will depend on the carrying distance. If the work is simply levelling across the road then 3 labourers would be used. If the fill material needs to be carried from another 20m section, he would choose 4, or even 5, workers for the filling works.

If the depth of the fill on the low side road shoulder is greater than 0.3m, there is no need for any side drain on the low side of the road. Make sure that the slope of the fill has a slope of 1:2 as shown in the figure below.

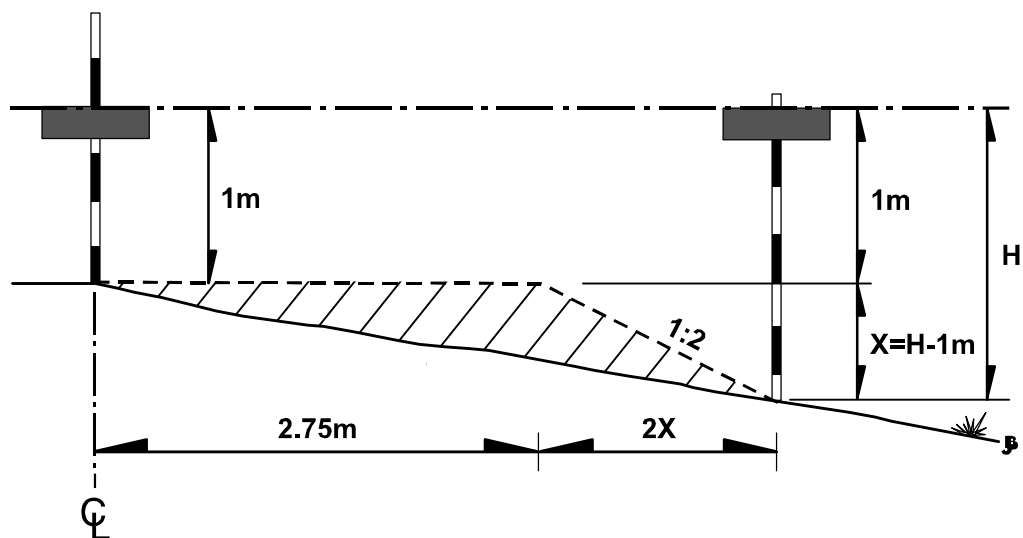

In order to produce a good quality fill on the low side, it is important that all soils are properly compacted. The fill is therefore built up in layers of 15cm which is properly compacted before a new layer is added. Also, make sure that the soils have the optimal moisture content when compacted. Compaction of the first layer may be necessary to do by using hand rammers.

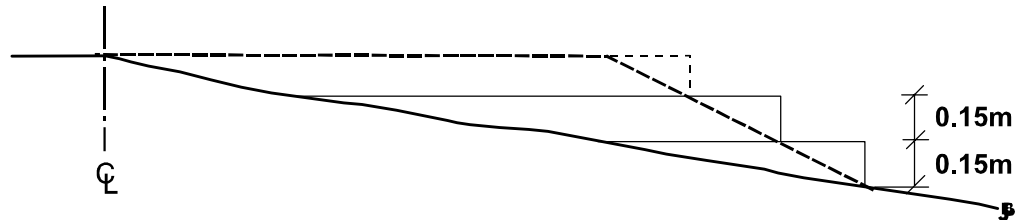

**Camber and Side Drain Construction**

Once the excavation and fill have been completed, the road camber is constructed using soils from the side drains and back slope. Excavated soils from the drains should first be thrown to the centre of the road, from where it is levelled out towards each road shoulder to form the camber.

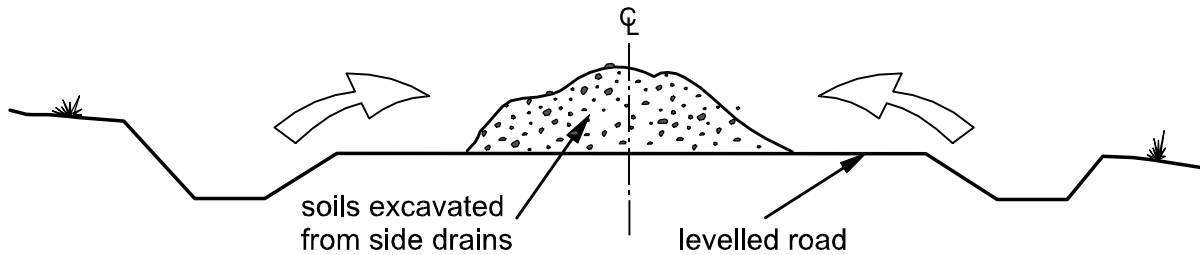

Side drain excavation is done in two stages. First the ditch is excavated, then the side slopes of the ditch is excavated. Normally, one or two days are allowed between each stage to allow sufficient working space for the workers. The side drain excavation is set out using string line and pegs, and controlled by using ditch templates.

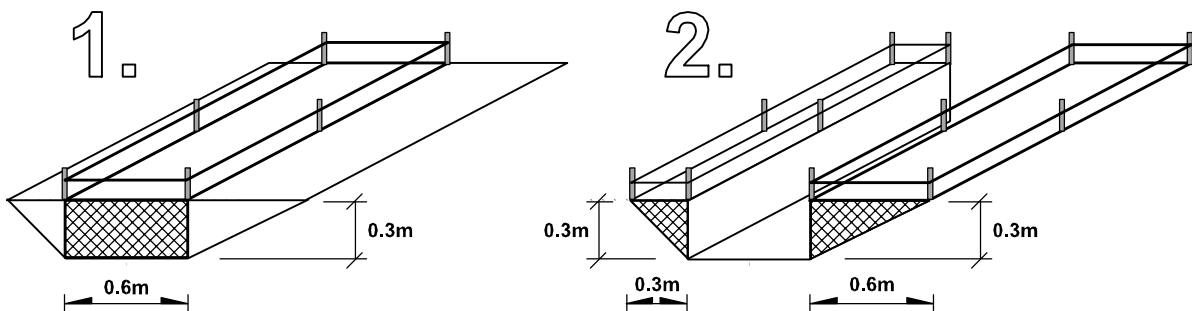

For both ditching and sloping, tasks are set as a length of the side drain for each worker. The sloping task is normally set slightly higher than the ditching task, because excavation of soil on the slope face is easier to carry out than excavating the ditch.

The soils excavated from the side drains are used to construct the road camber. To achieve an exact and properly levelled camber, the work is set out using pegs and strings.

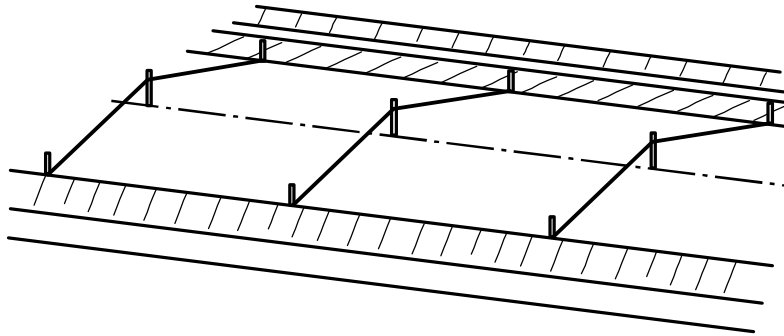

Once the soils for the camber has been levelled, the camber is properly compacted. Make sure that the soils contain optimal moisture content.

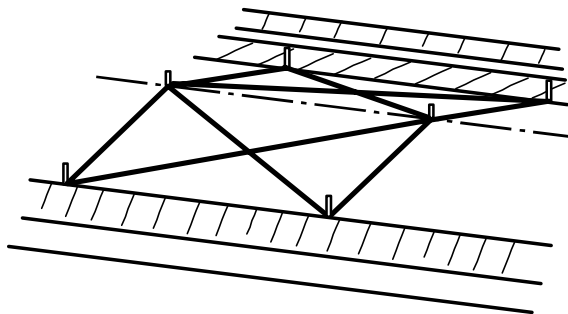

After compaction has been completed, it is important to check that the final levels of the road camber is exact and to the prescribed standard and quality. This can either be done by setting out the profile boards again and controlling the level between the profiles with a traveller. A quicker method, however less accurate, is to use string lines to check the level of the completed surface.

If the levels are in-accurate, the irregularities should be removed or filled in. If further filling is required, make sure that this patching is also properly compacted. Finally, repeat once again the checking of the levels to ensure that the earthworks are completed to the correct standards.

### Super-elevation of Curves

Super-elevation is applied to sharp curves, when the curve radius is less than 100m, to counteract the centrifugal force. Super-elevation is created by inverting the camber slope on the outer half of the road way, to prevent running vehicles from slipping of the road in the curve.

The super-elevation is gradually built up over a 20m section before entering into the curve.

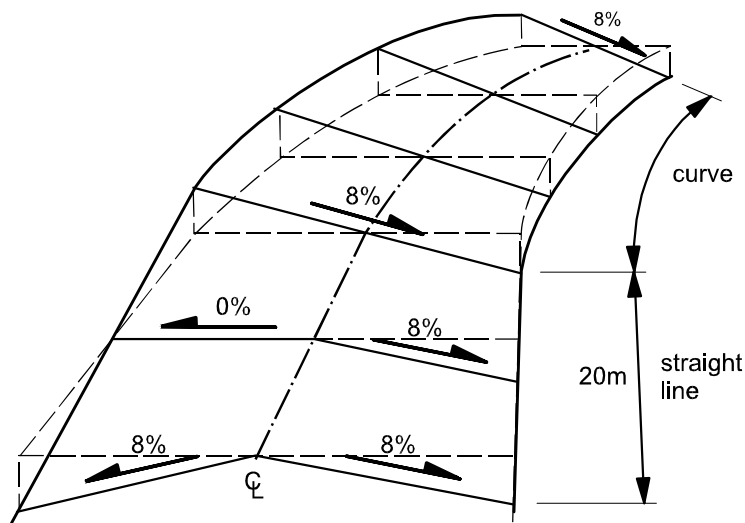

Equally, the super-elevation is run off over a 20m section starting at the end of the curve.

Throughout the curve, the super-elevation is constant, with a full cross slope of 8% across the road carriage width (10% before compaction).

Super-elevated curves, will require the double amount of materials to construct as compared to the standard camber formation. These additional materials should be obtained in close proximity to the curve to avoid any hauling distances.

Ideally, this can be achieved by enlarging side drains or reducing slopes of side cuts.

Finally, the super-elevation should be built up in compacted layers of 15cm.

### Reporting

The supervisor will report workdays each day as they are used, but he will report excavation in cubic metres only once the entire 20m section has been completed to levelled formation and back sloped. Similarly, side drains and camber formation is reported when entire 20m sections have been completed.

## 2.3 Embankment Construction

**E**mbankments require large amounts of fill material and are expensive to construct. They should be avoided when possible by selecting a longer route on higher ground. However, this is sometimes not possible in low, flat, agricultural land, where often no alternative route exists.

Wherever possible, material should be excavated alongside the road and carried to the road by baskets or wheelbarrows. If land is not available for roadside borrow pits, or if the material is not suitable, then earth will have to be brought in from the nearest source by appropriate haulage transport. The type of the borrowed soils should be of good quality. Organic soils, and if possible, sand and silt should be avoided. If sand or silt are the prevalent materials in the area, side slopes should be protected with at least a 15cm layer of clayey soils and vegetation to prevent erosion.

It is important to keep the height of the embankment to the least requirement. This is considered to be 0.5m above normal flood levels.

Highest annual flood levels are used to determine the embankment height. This information should be available from local inhabitants and should be marked on pegs along the centre line when choosing the alignment.

Centre line alignment should be carefully selected to avoid low areas requiring extra fills and areas where suitable material is not available from the roadside.

The below figure summarises the key dimensions of the cross-section of embankments utilised in the ILO labour-based road project.

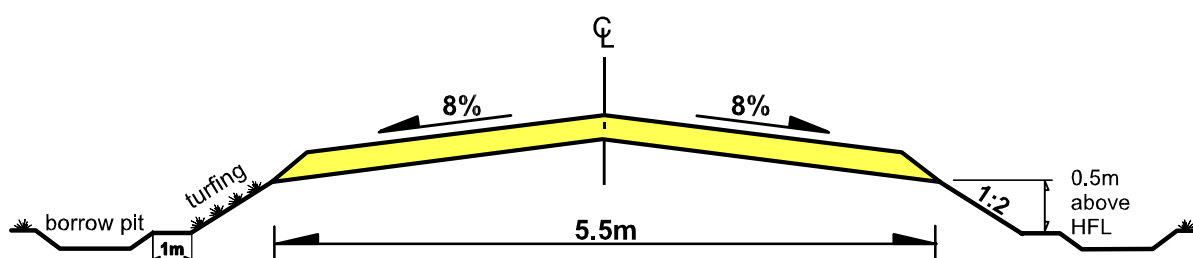

### Earthwork Volume Calculations

Calculation of earthwork quantities is especially important for the planning and control of embankment construction operations. It is necessary to apply a simple and accurate method of estimating embankment quantities at the site level.

The standard cross-section dimensions are fixed by national or programme specifications. In this example, we will assume the dimensions used by the ILO project, i.e. a road width of 5.5m, side slopes of 1:2 and a clearance above flood water of 0.5m.

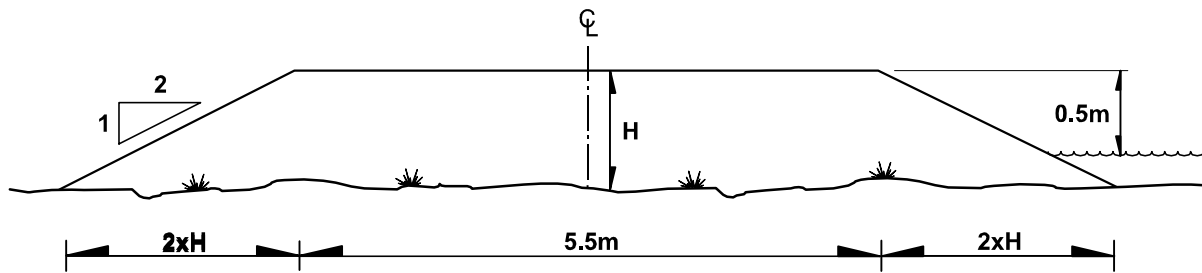

H, the height is fixed by the height of normal flood levels plus 0.5m.

The area of the standard cross-section is:  $(5.5 + 2H) \times H$  [m<sup>2</sup>]

Which is equivalent to m<sup>3</sup> per metre length when we calculate volumes.

For example, an embankment of 0.80m average height would have a cross-section area of:

$$(5.5 + 2 \times 0.8) \times 0.8 = 5.68 \text{ m}^2$$

or 5.68 m<sup>3</sup> per metre length

Embankments are only necessary on flat land where there are only slight variations in ground levels, and in these conditions, it is quite safe to take the height at the centre line profile as the average height of the cross-section.

The height of the embankment at any point on the centre line can be quickly found by the use of profile boards.

The high water level is marked on trees or strong pegs at convenient locations along the route according to local knowledge and indications. The centre line is then set out with ranging rods every 20m. Profile boards are fixed on these ranging rods at 1m above the nearest high water level mark.

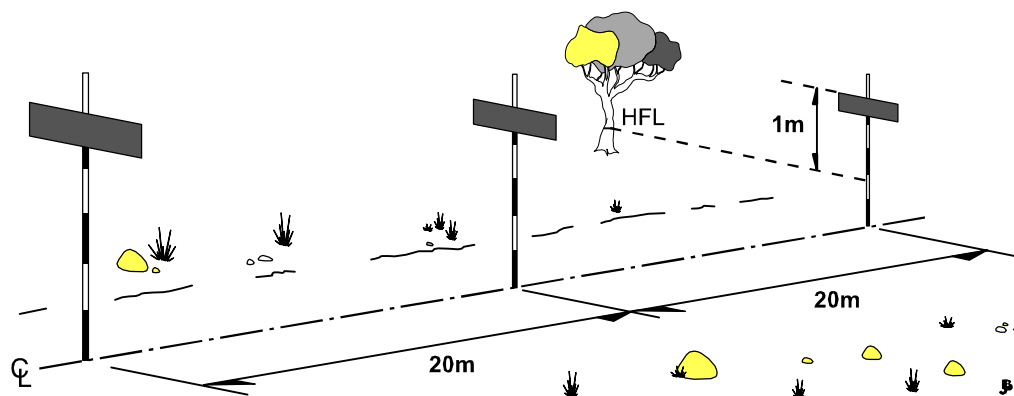

The centre line profiles are then sighted to check that they line up and are horizontal. Adjustments to the profile levels are made as necessary.

It is then possible to find the height of the embankment at each 20m section by measuring down from the profiles to the ground and subtracting 0.5m. The measurement is rounded off to the nearest 10cm.

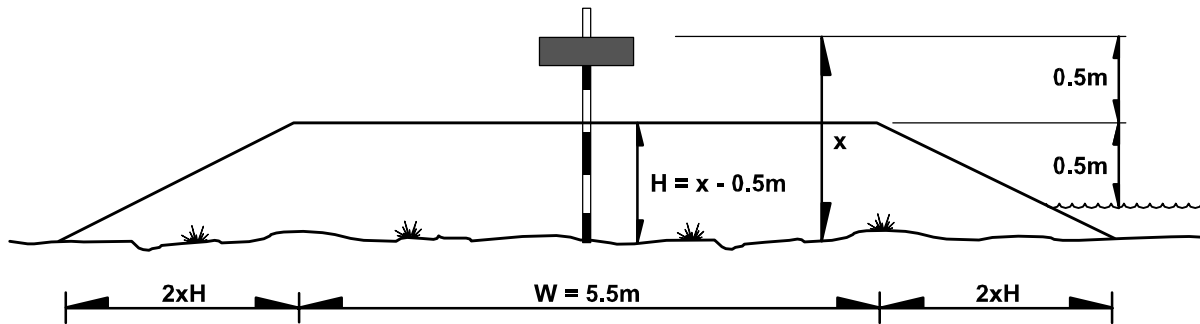

Volumes for 1m road lengths can be calculated for a series of embankment heights:

Embankment Height, H	1.00	0.90	0.80	0.70	0.60	0.50	0.40	0.30	0.20
Volume, m <sup>3</sup> /m	7.50	6.57	5.68	4.83	4.02	3.25	2.52	1.83	1.18

These figures can be used to estimate volumes over longer distances, say 100m, during planning or route investigation stages, to get quick, accurate estimates of the volume of earthworks and the workdays needed. In these cases, the engineer would establish high water levels along the route, and add 0.5m to give the sufficient embankment height, H.

Example:

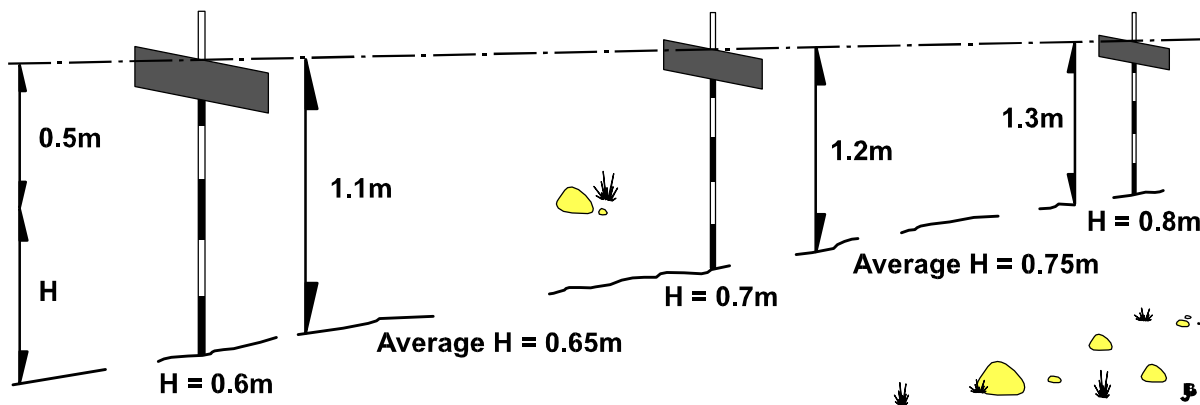

If we take the average height for each 20m section and apply these H values to the above table, we find that the first section has a volume of  $20 \times 4.42\text{m}^3 = 88\text{m}^3$  and the second section has a volume of  $20 \times 5.25\text{m}^3 = 105\text{m}^3$ .

Once the centre line profiles are established, it is possible, using the profiles, to get a fast, accurate estimate of the volume of earthworks and the workdays needed for every 20m section.

However, for the supervisor this does not give sufficient detail to organise the work on a day to day basis. The embankment will be built up in compacted layers. The width (W), of each layer depends on the gradient of the side slope and the height of the embankment.

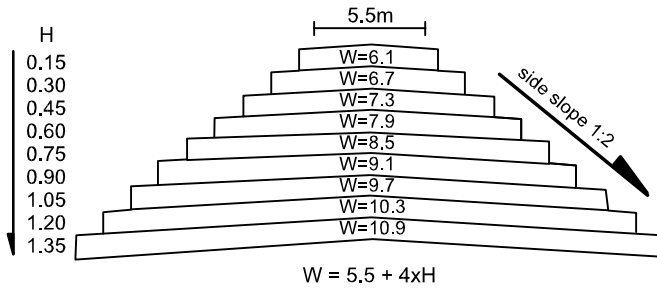

The thickness of the layers will depend on the method and equipment used for compaction. Let us assume compaction by a 1 tonne vibrating roller, which can compact a layer about 15cm thick. So, the embankment will need to be built in 15cm layers.

The supervisor needs to estimate the volume of each layer to be able to allocate the right number of labourers for the work each day. This is easy to calculate:

The first layer (at the top)	$6.1 \times 0.15 = 0.91\text{m}^3$ per metre or $18.3\text{m}^3/20\text{m}$ ,
the second layer	$6.7 \times 0.15 = 1.01\text{m}^3$ per metre or $20.1\text{m}^3/20\text{m}$ ,
the third layer	$7.3 \times 0.15 = 1.10\text{m}^3$ per metre or $21.9\text{m}^3/20\text{m}$ .

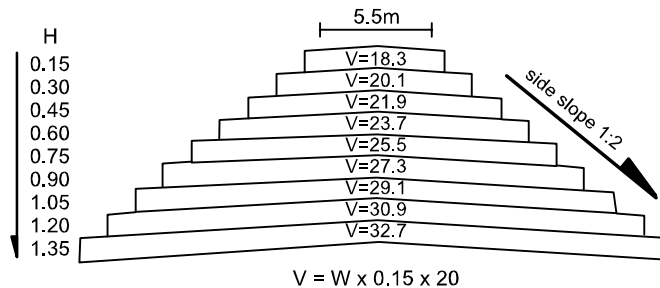

The ground on which the embankment is built will not be level and the height of the embankment will not always be exact multiples of 15cm. There will be a need for one or two regulating layers until we can build up in even 15cm layers.

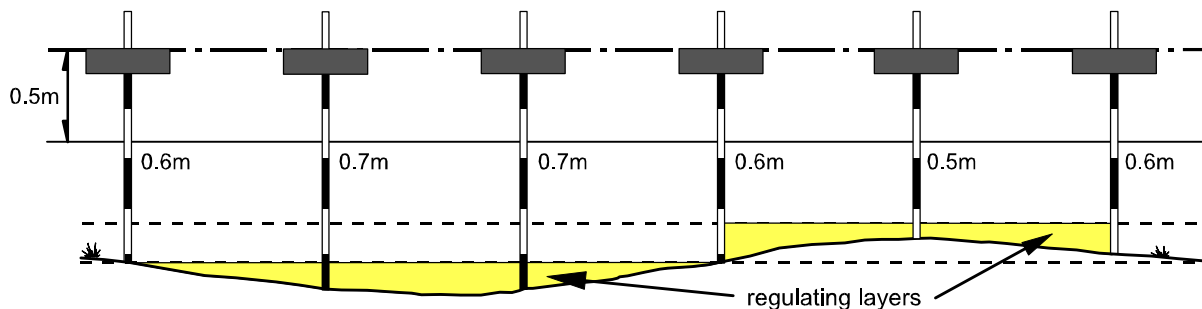

To calculate the regulating layers, we will need to make some practical assumptions:

- that ground levels are to be rounded to the nearest 10cm, and
- that the ground slope between points can be represented as a straight line.

It is then possible to calculate the volumes of layers of different thickness and shape.

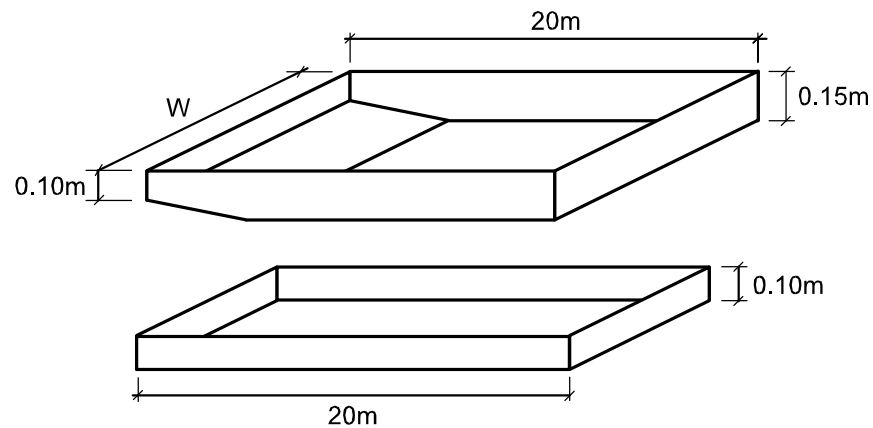

## Site Level Planning and Work Force Organisation

The volume of the various shaped layers depends on the width of each layer ( $W$ ), which depends on the depth of the layers below the top of the embankment. This means it is possible to calculate the volumes of various layers against the height ( $H$ ) of the embankment, measured up from the bottom of each layer. This calculation is important for establishing the correct number of workers to be distributed on the embankment construction.

When the supervisor is planning the construction of the embankment, the first thing to do is to level earthworks at the 0.45m, 0.60m, 0.75m, 0.90m or 1.05m levels so that filling can proceed in 15cm layers to the top of the embankment.

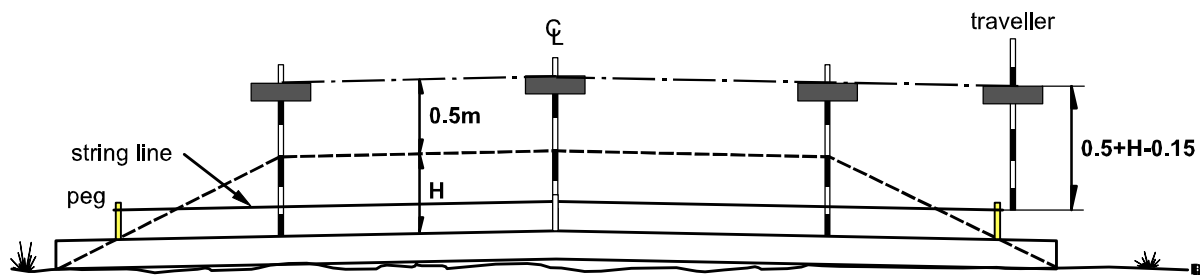

The fill is set out in layers measuring down from the top of the embankment and marked on string line pegs to aid levelling. The level marks is found by using a traveller and sighting off from the profiles.

In some cases, this will involve the use of regulating layers. After the regulating layers have been levelled and compacted, the construction will proceed with 15cm layers. The first 15cm layer may also involve some regulating.

Once the centre line profile measurements have been recorded, the edge of the road profiles should be set out and the centre line profile level transferred to them. The centre line ranging rods can then be removed to make the work area clear for compaction operations. At the same time, a strong marker peg should be driven into the ground at each 20m section and the high water level clearly marked so that construction levels can be replaced if needed.

Once the supervisor has found the earthwork quantities, layer by layer and section by section, he/she is in a position to organise the work force to carry out the work. The first thing to do is to decide the number of workdays needed for each layer and section by dividing the volume by the established task rate.

Although embankment earthworks would be the single largest activity in terms of output produced and workdays consumed, the supervisor will have to organise the allied and other activities involved, such as clearing, raking to level, trimming side slopes, turfing, etc.

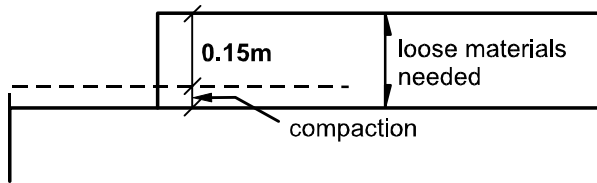

After each layer is compacted the next layer will need to be greater than 15cm to fill up to the top of the next layer and make up for the compaction in the previous layer. The earthwork quantities are for excavated compacted soil which will bulk ("expand") when

loose and provide the extra material needed.

## 2.4 Ditching, Sloping and Camber Formation

This section describes the setting out the road camber of a road section in rolling and hilly terrain. If the road needs to be elevated on an embankment, refer to Chapter 1.5 Embankment Construction.

Normally, the road camber is set out together with the side drains. Once the position and levels of the centre line has been determined, it is possible to construct the camber and side drains. The below figure summarises the key dimensions of the cross-section utilised in the ILO labour-based project.

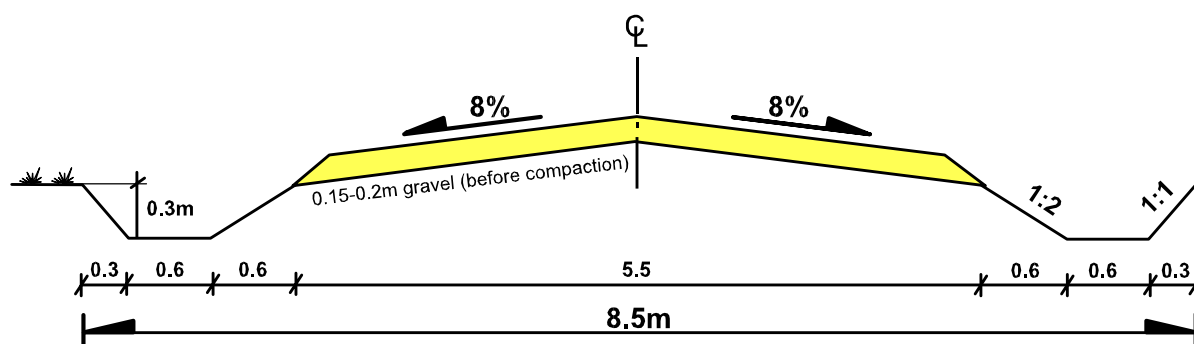

Note: In mountainous terrain, it may not be possible to adhere to the drain specifications as described above. In clayey soils, it is possible to increase the gradient of the side and back slopes.

### Setting Out the Road Camber

When setting out the road camber and side drains, it is important to reduce the amount of excavation to a minimum by following the existing level of the terrain along the road line. The procedure described below is an efficient way of setting out the road levels, achieving a well placed road with good drainage and which does not involve massive excavation and/or fill works.

- Step 1:** Using the previously set out centre line, set out ranging rods at 10m intervals along the centre line for a section of 50 to 100 metres. At the start of the section, measure out the position of the road shoulders and the outer end of the side drains from the centre line. Repeat this exercise at the other end of the section.

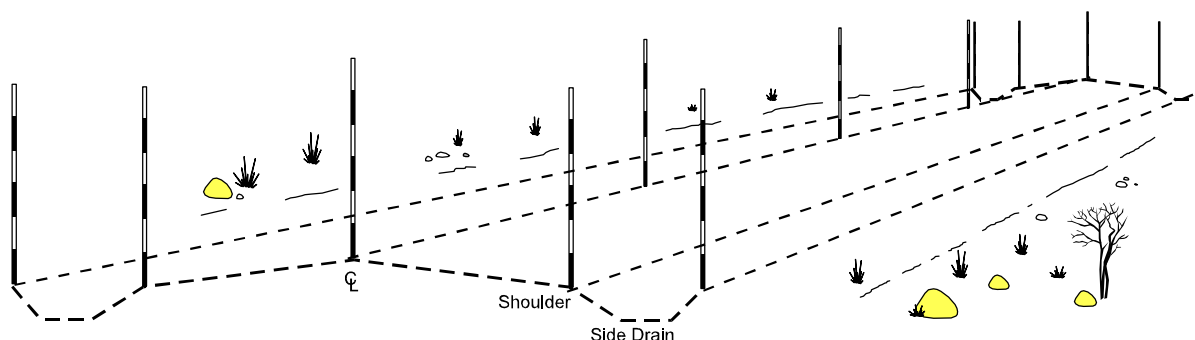

Place a wooden peg next to each of the ranging rods.

**Step 2:** Once the key positions of the road has been set out at the start and the end of the road section, sight in intermediate ranging rods at every 10m along the road shoulders and side drains.

Place wooden pegs next to each of the intermediate ranging rods.

**Step 3:** On the centre line of the road, fix the first profile board. This profile may be already in position as the last profile from the previous setting out. If not, measure 1m up from the existing ground level, and mark this level on the ranging rod. Fix a profile board to the ranging rod so that the top edge of the profile board is at the mark made on the rod.

**Step 4:** Go to the centre line ranging rod at the other end of the road section and repeat the procedure, measuring up 1m from the ground level.

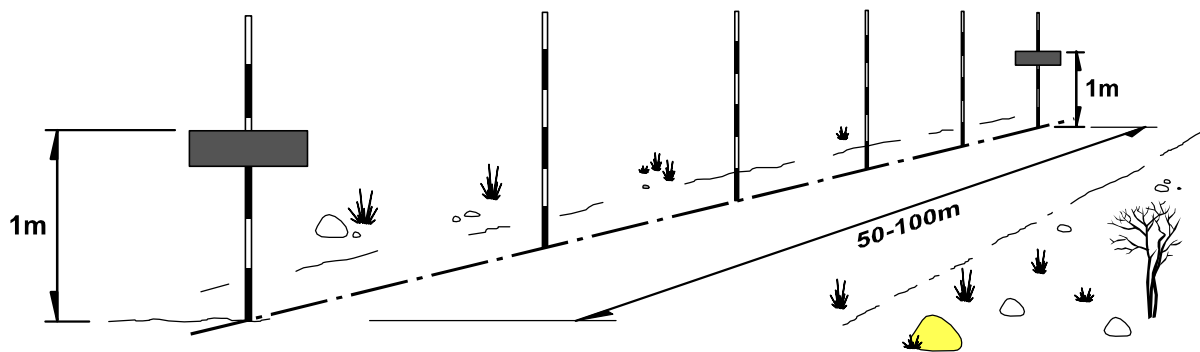

**Step 5:** By sighting in the intermediate profiles from one end, fix profile boards on the intermediate ranging rods along the centre line so that they are all at the same level.

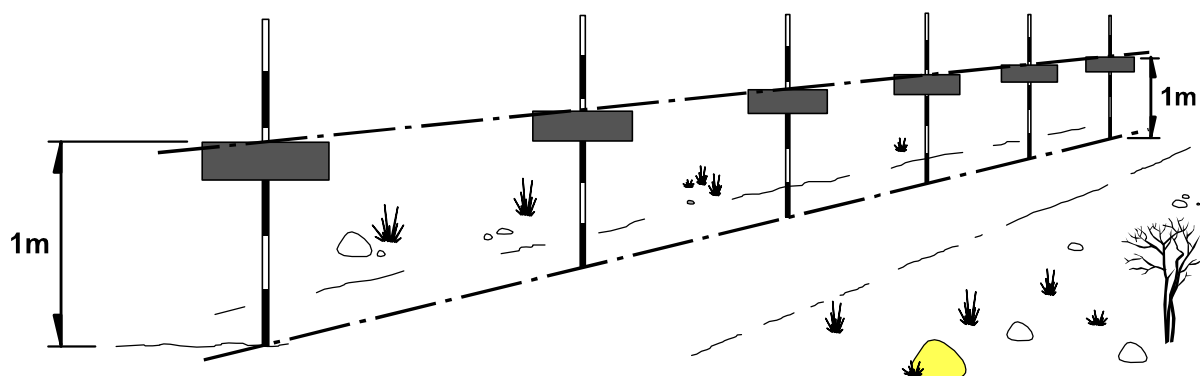

**Step 6:** Check the height of each profile board above the ground level. If the height is approximately 1m, there is no need to adjust them and you can use the level of the profile as it is.

If the height of the profile boards is greater or less than 1m by 10cm, then inspect the line. There may be humps or depressions along the line. The set out line will in most cases smooth out these variations. However, it may be that the set out line is over a hill or a dip in the terrain. In such cases, it is necessary to adjust the profiles to avoid too much excavation works as shown in the two figures below.

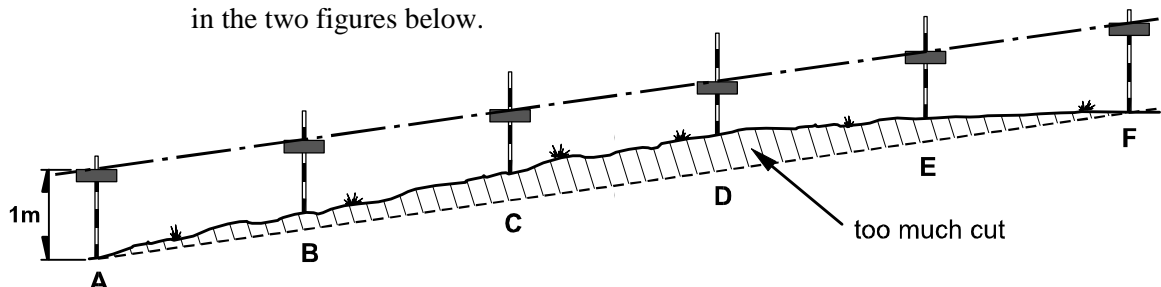

Adjust the profile at position D so that it is 1m above the ground and then lift the profiles at B, C and E to sight in line with the profiles at A to D and D to F. This exercise will reduce the amount of excavation works.

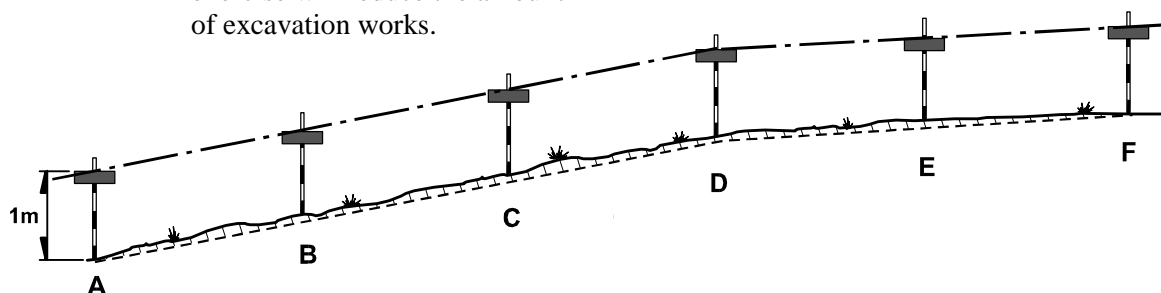

**General Rules**

1. It is better to lift profiles than to drop them.
2. Try to keep lifts and drops less than 10cm.
3. Try to match the road levels to the terrain.
4. Use the profiles to get a picture of the vertical road alignment.

Before starting on the next step, make sure that the side drains can be emptied. It is important to spend time on this step to get the levels right. All other levels will be set out based on the profiles along the centre line of the road.

**Step 7:** Transfer the levels to the ranging rods at the outer end of the side drains. Start with the beginning of your road section. Using a string and a line level, transfer the level of the profile board at the centre line to the ditches on the both sides of the road. Once the levels are set out with profile boards, mark the levels on pegs next to each ranging rod.

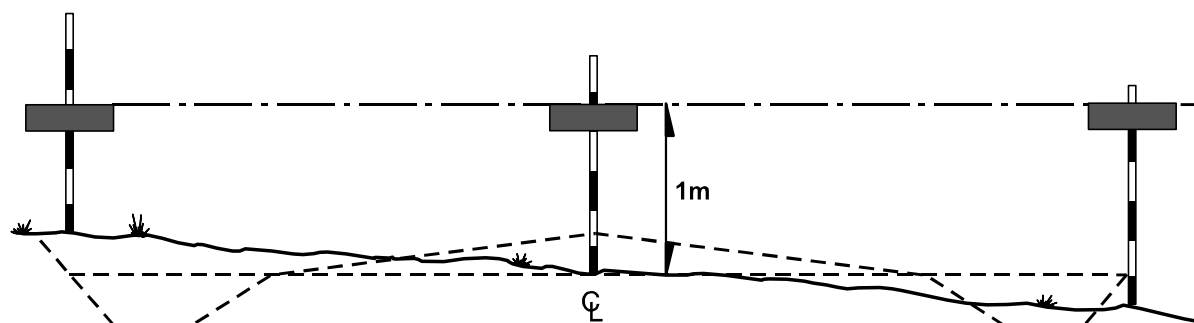

Repeat this procedure for the same two ranging rods at the other end of the road section and for any intermediate profile along the centre line that was lifted or lowered to reduce excavation works. Then, sight in the intermediate side drain levels.

You will notice that the height of the drain profile on the low side of the centre line is more than 1m in most cases. This is because we have started from higher grounds, and since the road is level, the lower side drains will be less deep.

**Step 8:** Mark the levels for the centre line on pegs placed next to the ranging rods along the centre line. Now use the centre line profile boards to set out intermediate pegs placed at every 5 m along the centre line. This is easily carried out with a 1m traveller. Mark these pegs at the point where the bottom of the traveller touches the peg, when lined up with the profiles. On all the centre line pegs, mark the level of the crest of the camber 0.25m above the 1m level on the pegs.

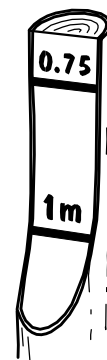

You have now set out the profiles for the levelling of this road section.

**Step 9:** Place the levels of the shoulders along the road. For this, it is useful to have a traveller 1m high. If we line up the traveller along the line between the two side drain profiles, the bottom of the traveller will show the correct level of the shoulder.

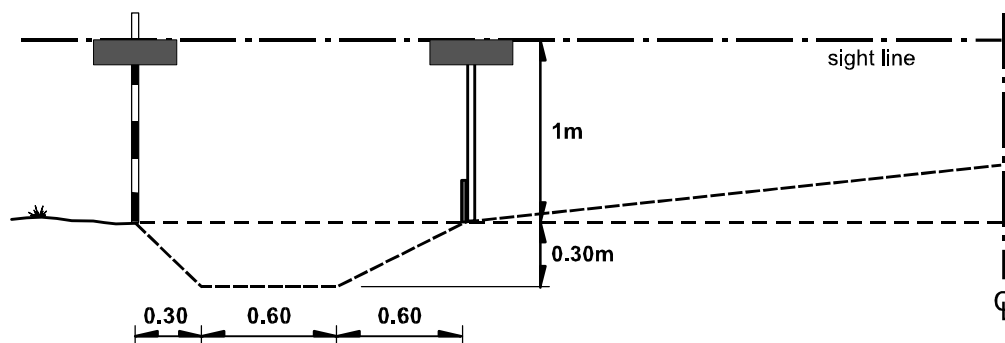

Place pegs every 5m along the edge of the shoulder, and using the traveller, mark these pegs at the point where the bottom of the traveller ends when it lines up with the profiles.

**Step 10:** Locate and set out the mitre drains. It is important that the mitre drains are set out before the excavation works for the side drains and camber is commenced. See Section 1.4 Off-road Drainage for setting out mitre drains.

**Step 11:** Set out with string line the side drains that needs to be excavated. Remember to leave out the mitre drain block-offs.

## 2.5 Off Road Drainage

The main problems for the side drains are erosion and silting. Erosion is caused by a large quantity of water travelling at high speeds. It is possible to reduce the speed by widening the side drain, but the best way to control erosion is by reducing the amount of water flowing through the drain. This is done by using *mitre drains* to empty the side drain at regular intervals before the volume of water builds up and causes erosion.

Another method to control erosion is to place *scour checks*. These are only used in hilly terrain with steep road gradients where it may not be possible to remove water using mitre drains. Their function is to slow down the water flow by reducing the natural gradient of the drain by allowing the drain to silt up behind the scour check.

Silting is caused by sand and silt settling out of the water. This only occurs with slow flowing, or stationary water. It takes time for the particles to settle, so the further the water has to travel in the drain, the more time there is for the silting to take place. The solution is to empty the side drains frequently by means of installing mitre drains at regular intervals.

In some cases, it is wise to construct cut-off or interception drains which prevents surface water from reaching the road. These are particularly useful in the surrounding areas to drift approaches, culverts and bridges. They are also effective in channelling away water from the high side of the road in side sloping terrain.



### Remember:

The best way to solve problems caused by the flow of water is normally to remove the water from the road before it causes a damage.

### Mitre Drains

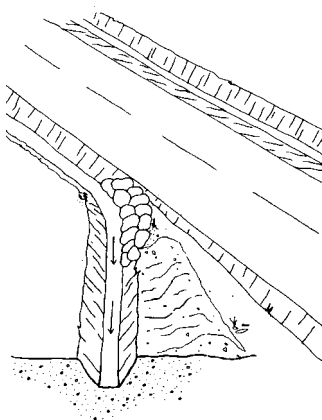

The location of mitre drains should be determined during the initial stages when setting out the road alignment, thereby ensuring that the road receives a good off road drainage. Make sure that sufficient numbers of mitre drains have been located before side drain excavation starts.

Calculating the correct space between the mitre drains can be quite complicated, in principle the more mitre drains provided, the better. A general rule is to:

- wherever possible, provide a mitre drain for every 100m or less, and
- when the road gradient is very small, provide mitre drains at every 50m along the side drain.

There are some important items to bear in mind when designing mitre drains:

- ✓ Make a strong block off in the side drain, and make it easy for the water to flow along and out of the mitre drain.

Water will always flow the easiest way. The water will try to continue to flow down the side of the road because it is usually steeper and in a straight line. If you want to divert the water into the mitre drain you must make it easier for it to flow where you want it to go.

The best way to provide a strong block-off is to leave 3 - 8m of natural ground on the drain line not excavated. Forming the block-off with excavated material is not as strong. Block-offs act as useful turning points for trucks and other equipment during the gravelling operation. They are also a natural point to off-load and store gravel for future routine maintenance works.

- ✓ The amount of water entering the mitre drain cannot be greater than the amount flowing out. Otherwise, the drain will fill up and over flow, often damaging the block off and causing even greater problems at the next mitre drain. In most cases, the standard mitre drain should be big enough to carry water coming from the standard side drain, except when:
  - the side drains carry more water than usual,
  - the side drain slope is much greater than the mitre drain slope

In such cases, the mitre drain should be made wider than the side drain so that it can carry more water.

- ✓ The length of the drain depends on the terrain ground levels and the slope of the drain. Mitre drains should be as short as possible. Long mitre drains are expensive, more likely to silt up or get blocked off, and in general more difficult to maintain.

A good slope for a mitre drain is 2%. The gradient should not exceed 5%, otherwise there may be erosion in the drain or to the land where the water is discharged. In mountainous terrain, it may be necessary to accept steeper gradients. In such cases, appropriate soil erosion measures should be considered. In flat terrain, a small gradient of 1% or even 0.5% may be necessary to discharge water, or to avoid very long drains. These low gradients should only be used when absolutely necessary. The slope should be continuous with no high or low spots.

- ✓ Try to select a line for the mitre drains which will connect with natural run-off channels that take the water well clear of the road. If this is not possible, make sure that the next mitre is set out to catch this water before it enters back into the side drains.
- ✓ Finally, it is important that the discharged water does not disturb farming activities in the surrounding areas. By discussing the location where to discharge water from the road with the local farmers, it may be possible to achieve solutions which may assist the farmers rather than destroying the water management of their farm lands.

### Angle of Mitre Drains

The angle between the mitre drain and the side drain should never be greater than 45 degrees. An angle of 30 degrees is ideal.

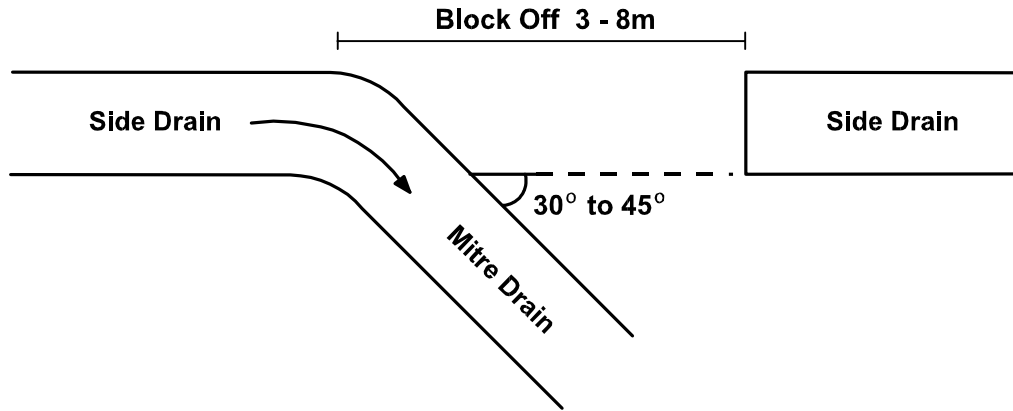

For checking, the angle between the mitre and side drain, first construct a 90 degree angle and then use the measurement of the below triangles:

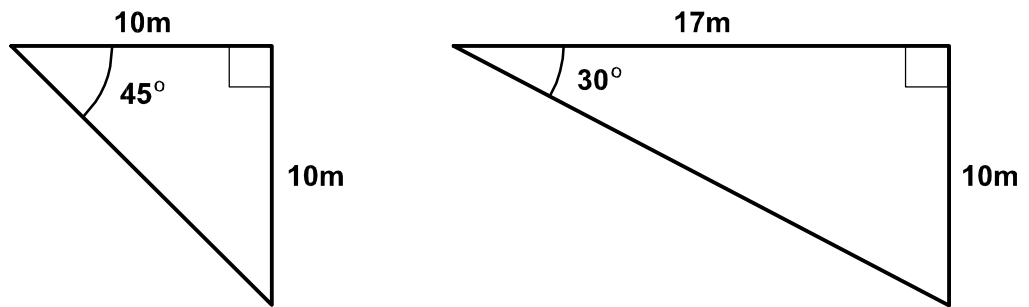

If it is necessary to take water off at an angle greater than 45°, it should be done in two or more bends so that each bend is less than 45°.

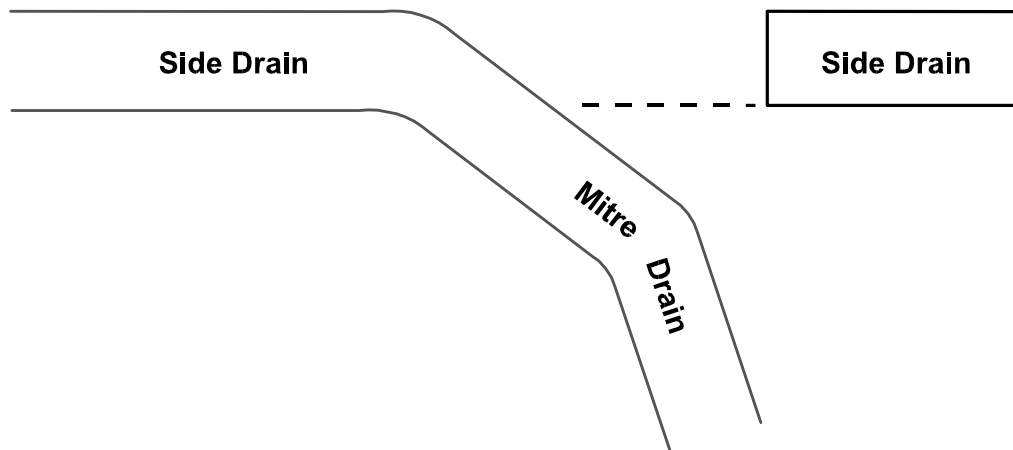

### Scour Checks

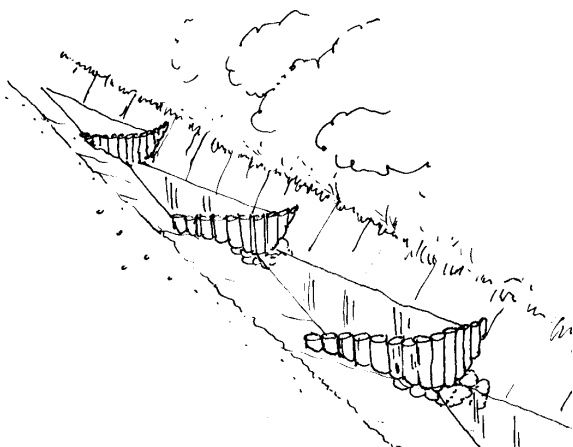

When road gradients are steeper than 4%, the drainage water will gain high speed which may cause erosion of the side drains. Apart from leading the water off in mitre drains, scour checks may reduce the speed of water and prevent the water from eroding the road structure.

Scour checks are usually constructed in natural stone or with wooden or bamboo stakes. By using natural building materials available along the road side, they can easily be maintained after the road has been completed. The distance between scour checks depend on the road gradient. This relation is shown in the following table.

Road Gradient [%]	Scour Check Interval [m]
4	not required
5	20
6	15
7	10
8	8
9	7
10	6

The basic measurements for constructing a drift is illustrated in the figure below:

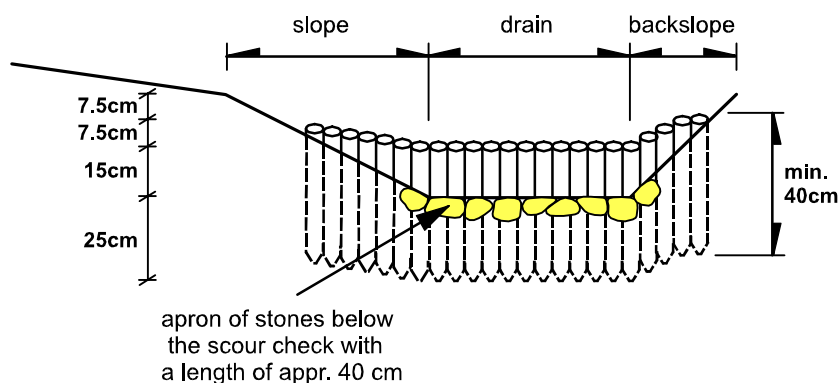

After the basic scour check has been constructed, an apron should be built immediately downstream using stones. The apron will help resist the forces of the waterfall created by the scour check. Sods of grass should be placed against the upstream face of the scour check wall to prevent water seeping through it and to encourage silting to commence on the upstream side. The long term goal is to establish complete grass covering over the silted scour checks to stabilise them.

## Cut-off Drains

The purpose of cut-off or interception drains is to prevent water from reaching the road, or to direct water to where it can cross the road safely at constructed water crossings such as culverts, bridges, drifts, etc.

These drains, when properly thought out, properly set out and properly built, can be very useful in reducing damage to the road and reducing maintenance costs.

In most cases, it is cheaper and safer to direct water away from the road, using these drains, rather than providing erosion control measures in the side drains. However, there are certain dangers with cut-off drains that must be considered:

- the water usually carries a lot of silt and if not properly built can silt up quickly,
- as they are off the road they will probably receive less maintenance - especially when they are difficult to maintain,
- when they fail, water will break through in a concentrated flow causing damage, and
- they may be ploughed up or blocked off by people using the land.

These dangers can only be avoided if careful planning goes into the drains before construction and if they are built properly. The following precautions should be taken:

- reduce the danger of silting by making sure there is a continuous down hill gradient and that there is a clear outlet at the end,
- make sure they are easy to maintain and that erosion damage is reduced so that maintenance needs are small (wide with sloped sides),
- make the drain strong - anticipate the possible weak points of the drain where water could break through and strengthen the drain there,
- locate drains carefully after discussion with local people - where people have to cross the drain, provide easy side slopes so that people will not fill the drain.

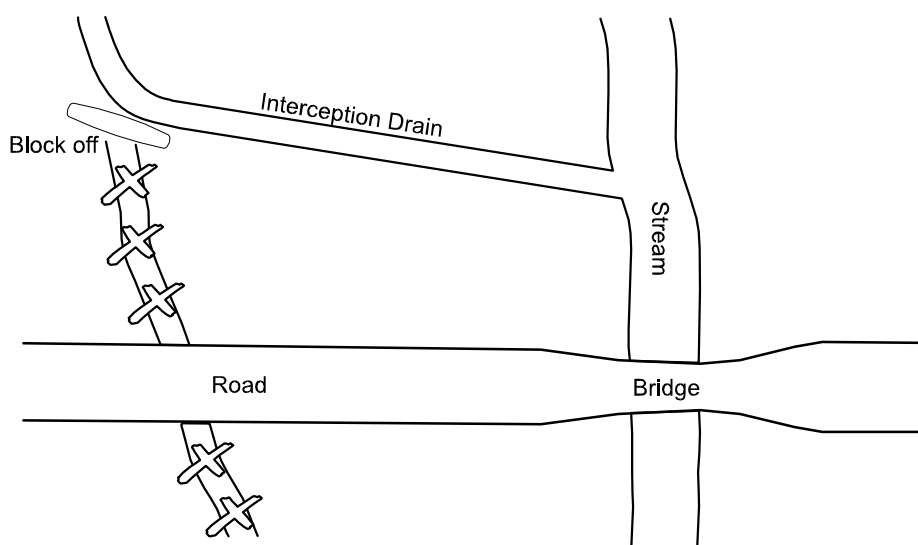

## 2.6 Compaction

**C**ompaction decreases the volume of a layer of soil. By forcing soil particles close together, the soil becomes stronger. By applying compaction to the materials used for road construction, the road body will be strengthened, and better withstand the envisaged traffic loads and natural erosion.

### Optimal Moisture Content

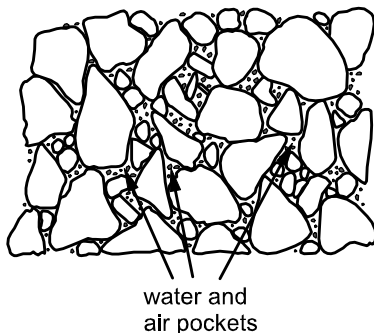

Soil and gravel in its natural state consists of solid particles, water and air. Air does not contribute to the strength and stability of the soil - on the contrary, it reduces the stability of a soil. A certain optimum quantity of water (usually between 8 to 20%, depending on the soil type) facilitates compaction and contributes to the soil's strength and stability, because it lubricates the particles and allows them to settle in a dense mass. If the soil contains too much moisture and is too wet, the soil particles are kept apart by the water. When the soil is too moist and you try to compact it, it will simply not compress, but flow out sideways.

Experience shows that if soil is taken from the ditches or a side borrow, and spread and compacted immediately, the natural moisture content is usually sufficient for good compaction. Sometimes, however, the soil comes from a dry stockpile and then needs to be watered.

It makes sense to check this so-called 'optimum moisture content', between too wet and too dry.

This is especially important for gravel layers. A simple way to check moisture content by approximation is to take some of the material you are to compact in your hand. Squeeze it into a ball. If the ball cannot be formed, the material is too dry. The correct moisture content is reached when you can form the ball and the material packs well together. When you apply pressure, the ball should retain its shape.

When you form the ball and flatten it easily when you put pressure on the ball, the sample has a moisture content which is too high. When the water oozes out of the sample without even applying pressure it obviously is too wet.

### Compaction Methods

There are basically four methods of compaction:

- manually or mechanically operated tampers or rammers,
- deadweight rollers,
- vibrating compaction, or
- natural compaction.



### Tampers and Rammers

Tampers and rammers compact the soils by impact. Hand rammers are cheap to produce, and consist of a long wooden handle with a cast iron or concrete weight at the end. It is lifted and dropped on the surface repeatedly to produce compaction. The weight is usually 6 to 8 kilograms.

Using hand rammers is expensive and difficult to apply evenly over large areas. A lot of manpower and direct supervision is needed to produce a steady output of reasonable quality. Hand rammers are most useful in small and confined areas such as around culverts, pot-holes and other places where it is impractical or difficult access for rollers.

### Deadweight Rollers

There are several types of deadweight rollers, ranging from single or double steel drums, towed or self-propelled or with a load container to hold the deadweight. A major concern when choosing the appropriate type of compaction equipment is:

- its availability in the region of your road works activities,
- how to deliver it to the construction site,
- how easy is it to operate and how easily can it be reversed, and
- its cost and reliability.

Large and heavy towed rollers may have good compaction qualities but may prove difficult to turn and operate in hilly or steep terrain. Self-propelled rollers can normally be operated in both directions, however, they are more prone to breakdowns.

Some rollers can be ballasted with weights up to 1 tonne or more, using water sand or stones. When using this type of roller, the first passes can be done with a relatively light ballast in order to avoid traction problems. After the first few passes the ballast can be increased.

### Vibrating Rollers

A vibrating roller will generally compact to a greater depth than a deadweight roller. The effect of the vibrating motion will depend on the intensity of the vibrations and the type of material on which it is used.

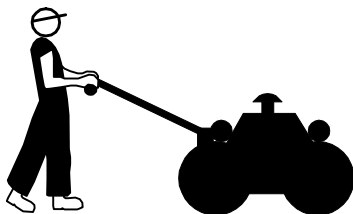

They also require a lower moisture content than deadweight rollers. However, it is important to maintain an even speed to achieve even compaction. With deadweight rollers this is less important.

The first passes, should be done without vibration, to avoid that the roller gets "bogged down" into the soil. The speed should be around 3 kilometres per hour or slow walking speed. Instruct your operators to run the engine at a slow and constant speed.

### Natural Compaction

The simplest method of compaction is by leaving soil to settle naturally by just leaving it for a period of time. The soil by its own weight, rainfall and people, animals and vehicles travelling on it will eventually consolidate enough to carry traffic loads.

This so-called 'indirect compaction' method or natural consolidation is a slow process. It is normally only used on very low fills, and is most effective if the fill material is very moist and must dry out. Given sufficient time, it has been found that roads compacted by natural consolidation can achieve similar densities as roads compacted by equipment. The main disadvantage is that while the soil is not consolidated, it is prone to erode more easily. Normally, it would be necessary to leave the fill for a period six months to achieve an effective degree of compaction.

**Quality Standards**

The required level of compaction is normally specified relative to a laboratory compaction test. For example, compaction to 95% means that the dry density of samples taken in the field should be 95% of the dry density obtained in a specified laboratory compaction test.

How to obtain a certain level of compaction will depend on the type and size of the compaction equipment and the soil type. The site engineer will prescribe the appropriate method and equipment for compaction.

A fairly reliable way of checking on site if compaction has been done to acceptable standards is to use a loaded vehicle. Drive it over the compacted section a few times and see if it leaves any wheel-ruts in the pavement. If ruts are left then more compaction is needed.

**Compaction Procedure**

To gain even compaction, assign and train specific workers to operate the compaction equipment. They will become experienced at running the rollers at a constant speed for good compaction and will also maintain the rollers.

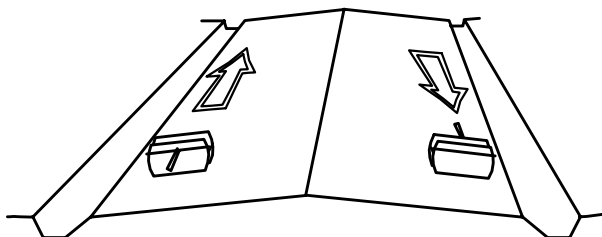

To produce a good quality road, it is important that all soils are properly compacted. Compaction should be carried out along the road line starting at the shoulder of the road and gradually working towards the centre line. Compaction of the road shoulders should be done using hand rammers.

Make sure that the camber of the road is always maintained at 8% for both the base layers as well as the gravel layer.

After compaction, it is important to check that all levels are correct and that the surface is smooth and does not contain any uneven spots. This check is carried out by using profile boards and a traveller.

Make sure that you have sufficient supply of water, in order to maintain an optimal moisture content in the soils which are being compacted.

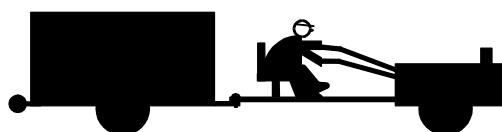

## 2.7 Culverts

**C**ulverts allow water to cross underneath the road to a place where it can be safely discharged. The water may be from natural streams or run-off surface water from the road structure.

### Siting of Culverts

The siting of culverts should be carried out during the initial setting out of the road alignment. It is important that the culverts are regarded as an integral part of the overall drainage system of the road.

If an existing road is being improved, most culvert sites will be obvious, because the road will have been damaged in some way. In such a situation, look for places where:

- ✓ small gullies have formed because water has been flowing across the road,
- ✓ sand has deposited on the road because of standing water, or
- ✓ drains have been badly damaged because they have been carrying too much water.

When determining the level of the culvert, make sure that there is a sufficient slope in the outlet drain, downstream of the culvert.

It is important to take great care concerning where the water is discharged. Water collected along the road and discharged through a culvert may produce serious soil erosion in the surrounding areas. When water needs to be discharged on to farm land, it is important to discuss the water management with the local farmers, thereby avoiding to damage or disrupt the farming activities. In some cases, it may be possible for the farmers to make use of the water.

### Description

The most common type of culvert is a single line of concrete pipes. The diameter should not be less than 0.6m, because smaller diameters are difficult to maintain and are easily blocked. The most common diameter is 0.6m but also 0.8m is frequently used.

Depending on the circumstances, instead of using large diameters which require a high fill over the rings (the overfill), two or more rows of a smaller dimension can be used.

The culvert bed has to be stable and at the correct level, i.e. preferably at the levels of the surrounding terrain. Remove stones which may damage the pipes. If the natural material is not suitable, a bed of gravel should be laid under the pipes. The bed should be constructed with a slope between 3 and 5%, using profile boards and a string line level.

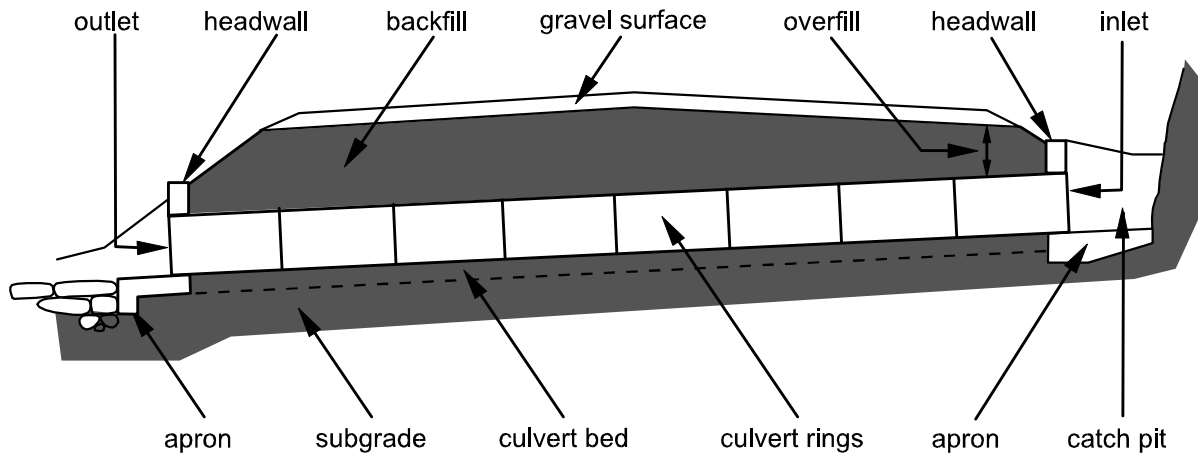

Aprons should be constructed at the inlets and the outlets to protect the culvert bed and the ditch bottom from erosion. They can be made by stones, masonry or concrete. Their length should at least be one and a half times the pipe diameter.

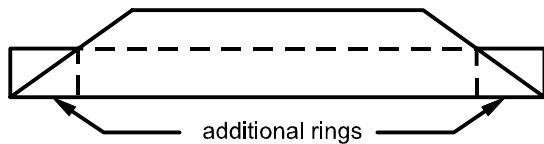

Head walls are produced to protect the backfill from water damage. They can be made of stones, masonry or concrete. If the head walls are omitted, make sure that the side slopes of the backfill is not steeper than 1:2 and that the culvert is long enough

to reach the end of the side slopes on each side of the road. If the natural soils are well graded and cohesive, the side slope of the backfill can be increased.

If the natural soils are good, the culvert can be installed using the in-situ soils as a culvert bed. By omitting aprons, head walls and culvert beds of imported materials, it is possible to reduce the cost of culvert installations by appr. 30%.

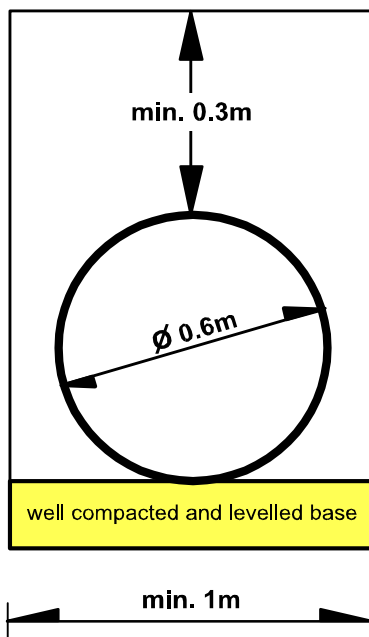

Once the location of the culvert has been determined, the culvert trench is excavated. If a 60cm culvert pipe is used, the width of the trench needs to be at least 1m to achieve good working space when placing the culvert. The excavation works should be organised as task work.

Once the trench has been excavated, check the level of the bottom with a traveller to ensure that it is level and with the desired slope. If necessary, use a 10cm layer of compacted gravel to achieve a solid foundation for the culvert. During excavation, ensure that any water which may enter the trench can run off. This may imply that the outlet drain needs to be excavated first.

The culvert pipes are gently lowered into the trench using a rope. Avoid the pipes falling onto each other. This may damage the pipes. Using crowbars, ease the pipes up tight against each other and ensure that all are in a straight line.

The backfill around the pipes and the overfill should be placed in 15cm layers of suitable fill material, and needs to be well

compacted using hand rammers. Be careful not to hit and damage the pipes when compacting. The minimum thickness of the fill above the culvert rings should be not less than half the pipe diameter.

In flat areas, it is often necessary to lift the road on an embankment in order to achieve sufficient fill on top of the culvert rings. In such cases, a ramp needs to be constructed on each side of the culvert to avoid a rapid change of the road gradient.

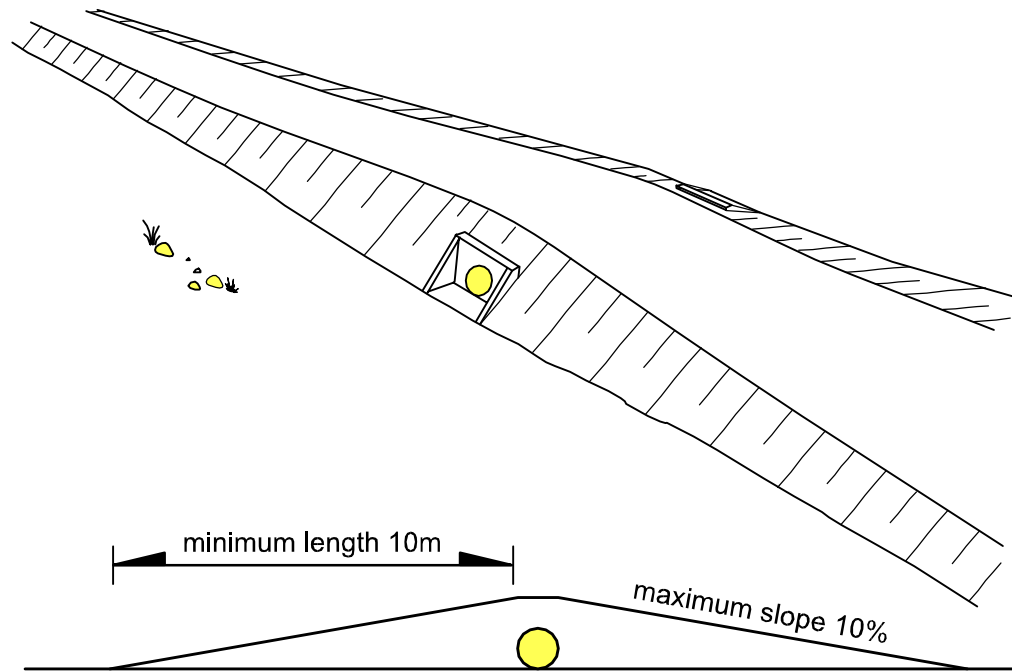

Finally, give serious concern to the outfall and undertake any additional works required such as properly forming an adequate outlet drain to discharge the water, providing grassing or dry masonry lining in the outlet drain, or stone gabion steps, or other interventions to ensure good erosion protection.

## 2.8 Drifts

**D**rifts provide a method of allowing water to cross from one side of a road to the other. In the case of drifts, the water is actually allowed to pass over the surface of the road. As a result the road surface will need special protection to stand up to the flow of water. This is usually done by making a stone packed or concrete surface where the water will pass. The level of the drift will be lower than the road on each side, to make sure that water does not spill over onto the unprotected road surface.

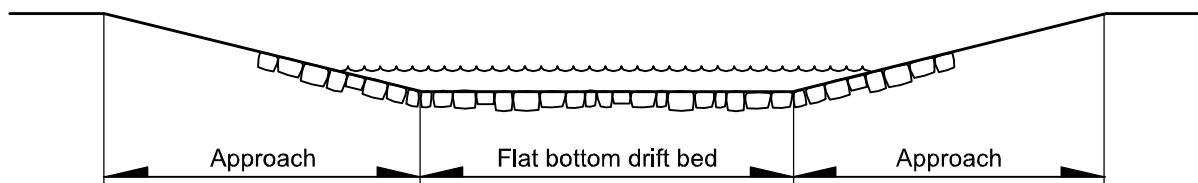

Drifts are normally constructed to pass river streams which are dry during long periods of the year.

During rains, most drifts will carry shallow flows of water which vehicles manage to pass through. However, occasionally, deep drifts will be flooded for short periods and the road will be closed for traffic.

There are three types of structures that are together known as drifts:

### (i) Splashes

These are minor crossings that carry water from a side drain across the road to the lower side. Splashes are located at low points along the road alignment and when the side drain cannot be emptied by mitre drains and the water has to be taken across the road.

### (ii) Drifts

These are crossings at large drainage channels and small rivers. They may have to take strong flows of water.

### (iii) River Crossings

These are long crossings over a sand river bed. Usually, the river bed would consist of deep sand and the crossing has to be built with a firm foundation.

## Drift Warning



Warning of the location of a drift or river crossing should be placed on the side of the road to give traffic sufficient advance notice so they can be prepared to reduce speed and proceed safely down the approach and across the drift.

Additional guidance can be given in the form of marker stones painted white at each corner of the drift.

## Procedure for Setting Out a Drift

The most important step is to locate a suitable site for the river crossing. If the drift is wrongly placed, it may result in both extra work during construction and maintenance afterwards. The main points to consider are:

- ✓ The angle between the centre line of the road and the flow of the water should be close to 90°.
- ✓ The site should be on a straight length of the stream bed.
- ✓ Avoid places where there are signs of scouring or silting. Both will cause future maintenance problems.
- ✓ Avoid places where there are steep banks which will involve a lot of excavation and steep approach slopes.

The site should be on a straight length of the road.

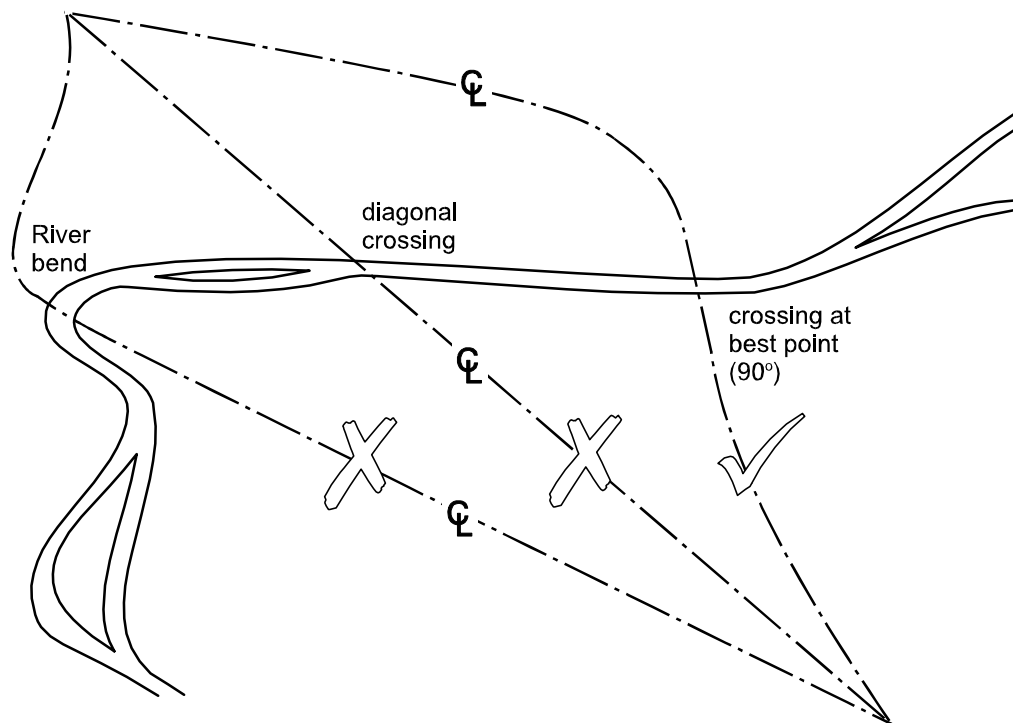

Once the site has been established, it is important to set out the finished level of the drift at the same level as the present level of the river bed. Avoid setting the level of the drift below or above the level of the river bed.

In cases where the river is suffering from silting up, it is best to lift the drift 20 -25cm above the natural rived bed. This will speed up the water passing over the drift and reduce the danger of the drift becoming silted up.

### Drift Approaches

The ideal slope for a drift approach is 5%. When we consider building a drift, we can set out the approaches first to see how much excavation is required.

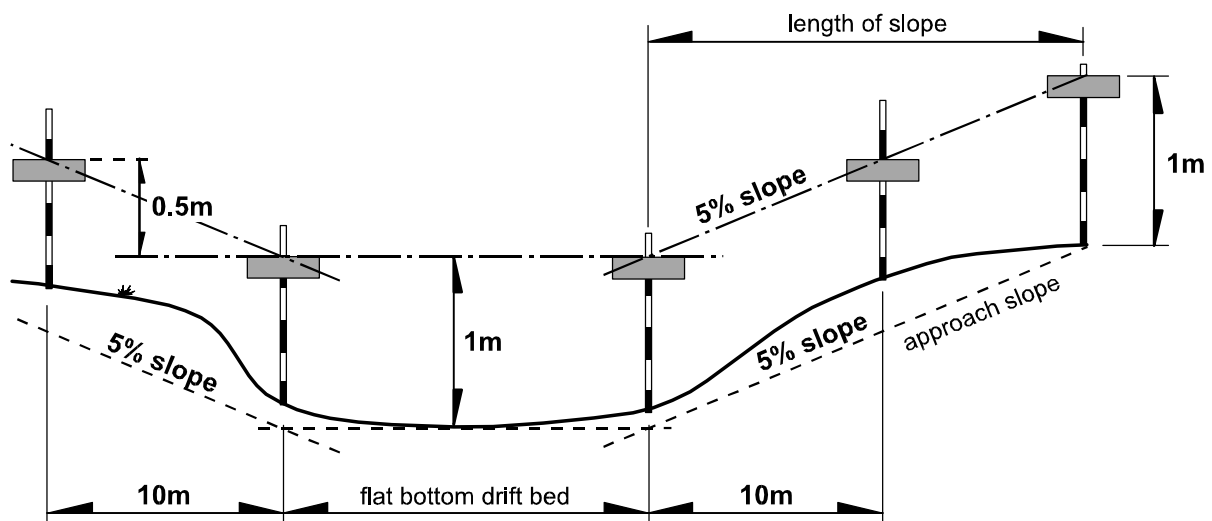

Two profiles are set out to a 5% slope at each side of the crossing. The length of the approach can be found by means of a traveller 1m high moved along the line of the slope profiles until it levels up with the slope profiles when standing on the natural ground.

The traveller can also be used to measure the depth of the dig along the proposed approach, and this can be used to estimate the volume of excavation required. It may indicate the need to look for another site for the drift.

### Surface Materials

To provide the appropriate surface material for the drift, which will support the expected traffic as well as stand up to the water flows in the rainy season, is an important issue.

There are a number of possible solutions from gabions with gravel, stone pavings to constructing a concrete slab. The choice depends on the following issues:

- the expected force of the water flow,
- the availability of materials, i.e. gravel, stones, concrete aggregate, sand etc.,
- the strength of the river bed foundation, and
- costs.

For slower flowing water, gravelled drifts with gabions or dry pitched stone paving is adequate. Stone pitching is more suitable for river beds with loose sands and a gentle flow.

With some crossings, it will be difficult to decide if a gravel surface will be practical - it may be washed out too often. In these cases, try the cheaper solution first, the gabions with gravel, and allow a full rainy season before deciding whether it is necessary to upgrade the crossing with a stone pavement or a concrete slab.

The figure below is an example of a drift which in principle consists of a porous dam which retains the gravel/rock from being carried away by the water flow. The top of the gabion dam is between 15 and 20cm higher than the river bed at the downstream end.

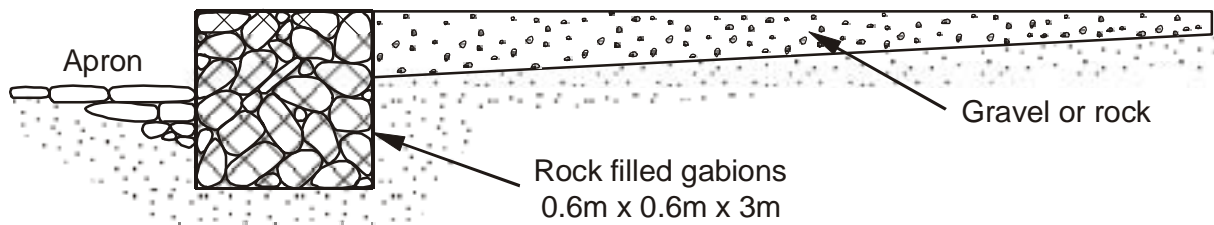

This construction provides a simple and economic solution. A one-metre wide trench is excavated along the downstream edge of the future road. The gabions are then placed in position, filled with rock and bound together with binding wire. Gravel is then placed upstream from the gabion to form the road surface. Remember to prepare an apron on the downstream side of the gabion to resist scouring.

Strong flows of water will erode and wash away gravel surfaces and will dislodge dry pitched stones. This will result in high maintenance costs to keep them repaired and in good condition for the road users. Where large volumes of strong flowing water are expected, a concrete slab or cement bonded stone paving provide the only long-lasting solution.

A typical cross section of a concrete slab is shown below.

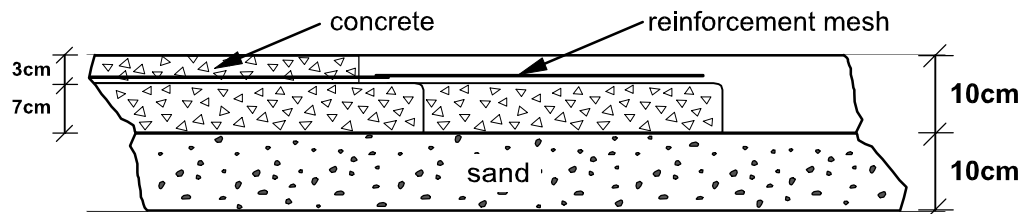

Once the concrete has been placed, keep it damp and let it cure for 7 to 10 days.

If the length of the slab is less than 12m there is no need for an expansion joint. On long river crossings, make expansion joints for approximately every 10 to 15 metres.

## 2.9 Gravelling

### Standards

ravelling is carried out to provide a strong surface layer which is passable in both dry and wet weather, and which does not deform under the expected traffic loads.

For rural roads, the ILO labour-based project has chosen a carriage width 5m wide which is fully gravelled with a layer of 15-20cm (before compaction). In addition, the road shoulders, with a width of 0.25m each, are gravelled to protect it from erosion as shown in the figure below.

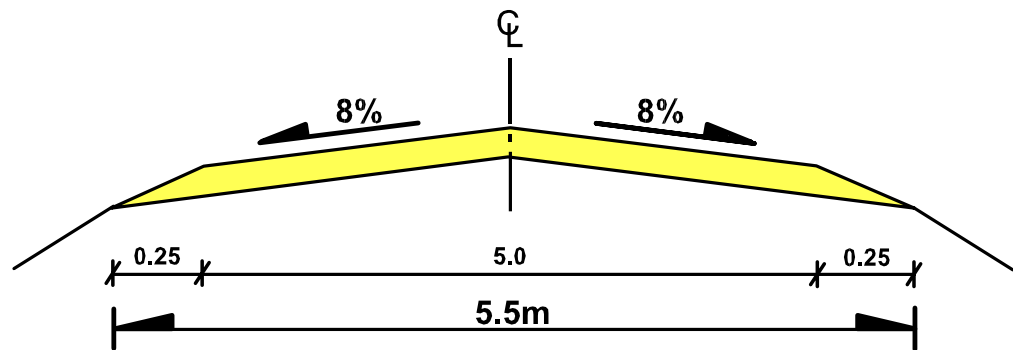

The road camber should be maintained at 8% (10% before compaction), similar to the sub-base.

### Gravel Source

When selecting a quarry, a number of aspects needs to be considered. These include:

- ✓ the quality of the gravel material,
- ✓ the depth of soil (or overburden) over the gravel,
- ✓ how to excavate the gravel,
- ✓ hauling distance from the quarry to the road site, and
- ✓ land ownership of the quarry site.

Preferably, the gravel pit should be located close to your road to limit hauling distances. Remember that gravelling can be quite expensive and can sometimes cost as much as the construction of the road itself.

## Gravel Quality

The quality of the gravel needs to be determined well in advance of the project commencing gravelling works. This enables the project to prepare and negotiate gravel sub-contracts with local contractors well in advance and to time the gravelling works to the optimal period of the year (dry season).

Good gravelling material should contain between 35 - 65% stones, 20 - 40% sand, and 10 - 25% clay.

If you have no experience with a particular material you can carry out some simple tests to see if the material is suitable.

Take a sample, moisten it and mould it into a ball. You can feel the sand and stones by the gritty feel of the sample when you squeeze it. When, after drying, the ball retains its shape, you can assume that there is enough clayey binder in the material.

You can also make a flat thick piece from the moist sample and try to penetrate it with a pencil. If the pencil penetrates easily, the material is not suitable because it contains too much binder or clayey material. If it is difficult to penetrate there is a sufficient proportion of fine and coarse materials which interlocks well.



An easy way to find out the proportions of the various soil fractions in the sample is to carry out a so called 'settling test'. The sample is put in a glass jar like this.

Only half the jar should be filled with the sample. Then add water till the jar is three-quarters full. Add some salt, as this will improve the settling of the finer materials. Shake the jar, and let the soil in the jar settle. As you will see the gravel and the coarse sand fractions will settle immediately. The finer sand and the coarse silt fractions settle more slowly. The clay and the fine silt will

remain in suspension for some time before they settle. You can see the proportion of each fraction as layers in the jar.

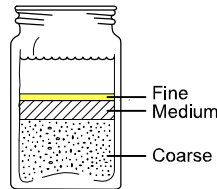
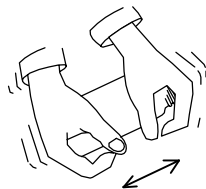

The results of these tests can only provide indications on how these soils could react when subjected to compaction, traffic and weather conditions. If you are still in doubt about the suitability of the gravel, consult your engineer to carry out laboratory tests to confirm your observations.

## Water

Good water sources is also important. When the gravel operation commences, the projects needs water haulage equipment available on site, i.e. a water pump, water bowser and an appropriate spreader. Make sure that this equipment is available and in good working condition before gravelling works starts.

## Work Plan

A proper workplan for gravelling is extremely important. This plan should give information on inputs (number of workers and equipment), productivities, outputs and timing of the work.

Always aim to organise the un-loading in such a way that waiting time for the vehicles is minimised. This implies that the supervisors needs to estimate the transport time from the road site to the quarry, and based on the number of trucks available, estimate how often a truck will deliver a load. This will indicate how much time is available for the spreading and levelling the gravel delivered by each truck. Ideally, the workers should be able to spread and level the gravel before a new load arrives on site.

There are two ways to organise the un-loading, gravelling *towards* or *away* from the quarry.

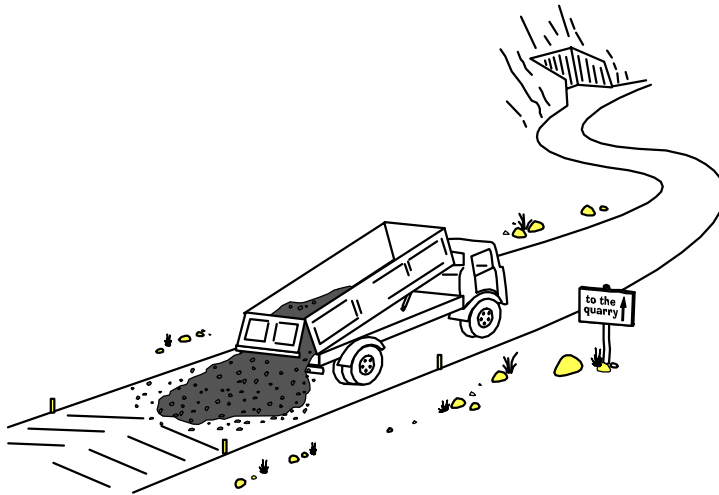

Gravelling towards the quarry can be organised in such a way that the vehicles have very short waiting times for un-loading, even if several vehicles arrive at the same time. However, this method requires the trucks to drive over the road sections which has still not been gravelled, which may cause damage to the road, especially in rainy periods. It may even become impossible to continue the works, as the earth road may become too slippery and muddy.

Gravelling away from the quarry implies that the trucks will pass over the newly completed road sections. This method has the advantage that the vehicles frequently pass over the newly levelled gravel and thereby provide some compaction to the gravel layer. However, this method also have some disadvantages. It requires that the delivered gravel needs to be levelled before a new truck can dump its gravel and may therefore delay the un-loading. Finally, a large number of heavy traffic on the road may result in some damages to the newly constructed road.

Therefore, the gravelling operation needs to be carefully planned, depending on the situation and the general conditions under which the project is working.

## Work Procedure

Before carrying out any gravelling works, first check that the earth works have been properly carried out and levelled to the exact and required standards. Set up the profile boards once again, and ensure that all levels are correct and that the camber has not been damaged.

Placing the gravel, involves four activities, namely un-loading, spreading, watering and compaction.

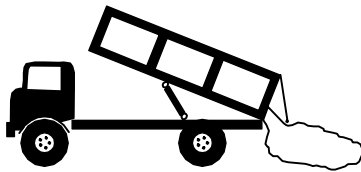

Un-loading



Spreading



Watering

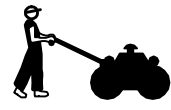

Compacting

These activities need to be fine tuned with each other, achieving a good balance between labour and equipment.

### Unloading

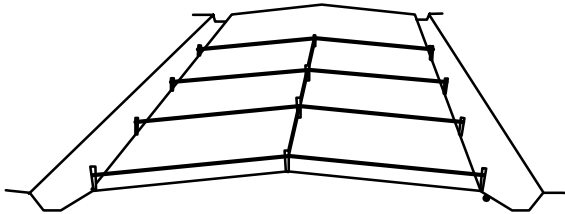

Drivers should be instructed to dump the entire load within an area which you have clearly marked with pegs and string lines. To make spreading easier, instruct the drivers to move slowly forward while dumping, so that the gravel is evenly distributed along the length of the rectangular area.

The area set out for each load of gravel depends on (i) the dimensions of the gravel surface and (ii) the average load which each of the trucks are carrying. In order to get the correct thickness of gravel, this needs to be carefully calculated by the site supervisor.

### Example:

If the desired thickness of the gravel is 20cm, then one meter of the road will need

$$0.2m \cdot (5m + 0.25m) \cdot 1m = 1.05m^3$$

If the average load of a truck is  $12m^3$ , this load will cover a road section with the following length:

$$12m^3 \div 1.05m^3 \text{ per } m = \underline{11.42m}$$

### Spreading

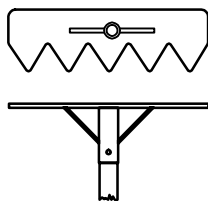

Once the material is unloaded, you can start the spreading. Take care to spread immediately before compaction to make use of the natural moisture content of the material. If the gravel is stock-piled along the road for a period of days before levelling and compaction is carried out, it will dry out and will then require more water when compacted.

The workers should use special spreading rakes, as shown here, or hoes to spread the material evenly onto the road base. Work from the centre line towards the shoulder, and spread one side of the centre line at a time.

Oversize pieces of rock should be removed or crushed using sledge hammers.

## Compaction and Watering

When the layer has been spread, the last activity of the gravelling operation, the compaction of the layer can be done. Make sure that you have sufficient supply of water, to maintain an optimal moisture content in the gravel during compaction.

If the gravel is spread immediately after excavation, it will contain a natural moisture content very close to the optimal, thereby reducing the demand for watering.

## Control of Works

Finally, when the gravel has been spread and compacted, erect profile boards along the centre line and the road shoulders. Then, using a traveller, control that the road surface is at the desired levels and smooth, and that the required camber slope has been achieved throughout the road line.

## Stock-piling

During the gravelling operation, it is useful to stock-pile gravel along the road for future routine maintenance works. This gravel will later be used for repairing damages to the road surface, i.e. pothole patching, filling of ruts, etc. Ideally, a load of 10m<sup>3</sup> of gravel should be placed along the road side, at 500m intervals.

## Reporting

A good reporting system is essential to keep track of the inputs (labour, tools, materials, equipment and fuel) and the outputs (amount of gravel delivered and length of road completed).

When reporting the output of the gravelling operation, volumes should be reported for road sections where the gravel surface has been fully levelled, watered and compacted to desired standards.

If a private contractor is engaged to provide the gravel, it is important that the site supervisor keeps detailed track of how many loads and the size of each load delivered on site.

## 2.10 Erosion Protection

Newly formed slopes on fills and embankments can be easily damaged (by run-off surface water, cattle, etc.). It is therefore necessary to protect the slopes as soon as they have been constructed. The erosion protection can be of different types, the most common being planting grass or other types of deep rooted vegetation. A more expensive but fast and effective method is to use stones for protection.

Grass can provide very effective protection against erosion if the right method of planting and the right type of grass is used. The planting can be done either by

- planting grass runners, or
- covering the slopes with turf.

### Grass Runners

Grass which has been removed by the grubbing gang can often be used if it is dug out properly and kept moist. It should be protected from direct sun. The runners are cut

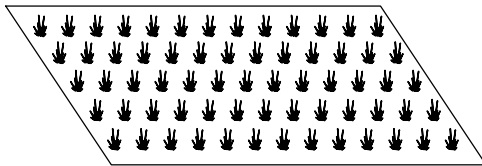

in pieces of approximately 20cm in length and planted in rows in 10cm deep holes with a distance of not more than 30cm. To get the best results, the rows should be skewed so that a zig-zag pattern is achieved. The soil should be compacted around the runners by hand.

### Turfing

Covering the slopes with whole turfs gives a more immediate and more effective protection, but is more time consuming to carry out. As with runners, the turfs can be collected during the grubbing activity. For easy handling, the turfs should be approximately 20 x 20cm. Care must be taken when cutting the turf so that the roots are not cut off. Turfs also need to be kept damp and away from the sun when stored. Before placing the turf, the soil should be watered if it is dry.

The newly planted grass needs to be protected from cattle by a layer of thorny bushes, twigs, branches, etc. and watered when necessary.



# **Chapter 3**

## **Site Administration**

---



## Chapter 3

# Site Administration

---

<b>3.1</b>	<b>Setting Up a Camp</b>	<b>70</b>
	Location	70
	Migrant Labour	71
<b>3.2</b>	<b>Hand Tools</b>	<b>72</b>
	Supply of Tools	72
	Maintenance	72
	Storage	73
<b>3.3</b>	<b>Materials</b>	<b>74</b>
	Fuel, Oil and Lubricants	74
	Culvert Rings	74
	Cement	74
	Pegs	74
<b>3.4</b>	<b>Maintenance of Equipment</b>	<b>75</b>
<b>3.5</b>	<b>Site Support Activities</b>	<b>76</b>
	Drinking Water	76
	First Aid	76

## 3.1 Setting Up a Camp

**B**efore road construction works commence, a site camp needs to be set up to accommodate the supervisors, materials, tools and equipment. The site camp needs careful planning to provide site staff with a basic comfort, and adequate storage and security for equipment and materials.

### Location

The selection of a suitable camp location should be made by the supervisor and the engineer and must take the following items into consideration:

- ✓ it should be close to the construction site, preferably in walking distance,
- ✓ it should have access to drinking water,
- ✓ it should be located on high, well-drained land,
- ✓ it should have sufficient space for parking equipment after working hours, and
- ✓ it should be easily accessible to project vehicles bringing equipment and materials.

The size of the camp depends on the size of your project, what type of works you are carrying out and how far you are from headquarters.

In most cases, the site camp can be set up in a local village through which the road will pass. Then, suitable accommodation and stores can be rented from the local villagers. In more remote places, the entire site needs to be established by the project.



### Remember:

Rents for stores and accommodation can be negotiated by the site supervisor, but should be approved by the engineer before the facilities are occupied.

The owner of the house must send an invoice to the project for the agreed amount at the end of every month. The site supervisor may help the owner if he has problems doing this.

Standard requirements for a site camp are:

- ✓ accommodation for the supervisors and equipment operators,
- ✓ a site office,
- ✓ a site store,
- ✓ appropriate cooking facilities,
- ✓ toilet and bathroom facilities, and
- ✓ extra site store for fuel, oil and lubricants.

For a road construction project covering more than 7 to 8 kilometres, the camp will probably have to be moved once, twice or even several times. These moves have to be planned well in advance so that the necessary transport can be arranged.

### **Migrant Labour**

Normally, labour is recruited from the villages in the vicinity of the road alignment. However in some cases, the road works is located in very remote areas where there is a limited supply of labour. If the travelling distance to the road site is too long, workers need to be housed on site. Unless local housing is available for the migrant labour, this will require a considerably larger camp. In such a situation, temporary dwellings and proper sanitation facilities need to be erected at the camp. In addition, arrangements need to be made so that the labour have regular access to markets.

Obviously, this is a more expensive solution to labour recruitment and should be avoided if possible.

## 3.2 Hand Tools

### Supply of Tools

**T**ool requirements depend on various factors such as the size of the project, soil types, terrain and the type of works which are planned. The below table indicates the required hand tools for a project employing a labour force of 100 workers or 250 workers.

Item	200 workers	100 workers
Profile Board	100	70
Ranging Rod	100	70
Hoe	150	70
Hoe Handle	150	50
Shovel	75	50
Spade	30	20
Pickaxe	75	25
Pickaxe Handle	75	25
Crowbar	10	5
Bush Knife	10	5
Axe	15	5
Bowsaw	7	4
Grass Slasher	15	10
Heavy Duty Rake	40	30
Hand Rammer	25	20
Wheelbarrow	60	40
Sledge Hammer	3	3
Bucket	10	8
Watering Can	10	8
Fuel pump	1	1
30m Measuring Tape	3	3
3m Measuring Tape	3	3
Line Level	3	3
Nylon String	300 m	300 m

### Maintenance



Ensure that the tools on site are in good order, that the tools are sharp and that the handles are firmly fitted and not damaged. When you find damaged tools on site, report this to the store keeper and have them repaired or replaced immediately. This will increase work efficiency and enable the workers to complete their task work on time.

On large projects, it may be useful to employ a person to maintain and repair hand-tools. Alternatively, it is always useful to check with the local villagers if there are any blacksmiths or carpenters available in the neighbourhood.

Make sure that the camp is equipped with effective sharpening tools and a sufficient supply of spare parts. The tools required to carry out routine maintenance are cheap and simple to use.

The cutting edges of axes, hoes, mattocks and grass slashers are normally sharpened with wet-stones. The edges of other cutting tools are best kept sharp by a selection of flat, half round and round files. For saws, small triangular shaped files, with a side about twice the depth of the teeth are appropriate.

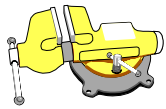

A simple vice should be available at the site store to enable the store keeper to work efficiently. A vice will enable hand tools to be firmly gripped when maintained or repaired.

Have a sufficient supply of spare handles on site. A loose or damaged handle is dangerous and should be fixed immediately. Purchase good quality handles made of hard wood which are properly designed according to established standards. Do not rely on makeshift handles made locally on site.



Wheelbarrows need a lot of maintenance to remain serviceable. Each day, all bolts and nuts should be tightened. If a bolt is lost, it should be replaced before the wheelbarrow is used again. If the wheelbarrows have pneumatic tires, supply the store keeper with a pump and patching equipment.

### Storage

Tools are issued by the store keeper to the workers every morning and returned in the afternoon after completion of works. Ensure that the workers are issued the correct type of tools according to the work activity they will be carrying out. The store keeper is responsible for keeping full records of the tools and controlling the daily issue of tools to the workers. The total amount of tools on site needs to be counted regularly and reported back to headquarters.

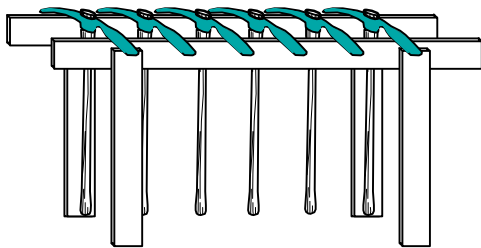

The size of the store depends on the amount of tools to be stored. When the road site is very isolated, the store has to be well stocked and therefore tends to be larger in size.

Tools should be stored in a dry and secure place. Stock the items neatly so that they can easily be counted. Stock different items separately and stock items of different sizes separately.

If necessary, employ a watchman to guard the stores when the storekeeper is off duty.

### 3.3 Materials

**S**upply of materials should be made well in advance of its planned consumption. Ensure that sufficient materials are available on site before commencing the works for which the materials are planned for. Also, notify the engineer in good time when stores needs to be replenished.

When materials are received on site, it is the responsibility of the store keeper to inspect and verify that the stores are in good order and correct quantity. Finally, the materials are recorded in the stores ledger.

#### Fuel, Oil and Lubricants

Fuel, oil and lubricants should be stored separately, away from the other supplies. These items can be a fire hazard, if not treated properly. Make sure that there are no open fires nearby, such as fire places for cooking, etc.

Fuel is normally stored in drums. Make sure that all consumption of fuel, oil and lubricants are properly recorded and accounted for.

#### Culvert Rings

Culvert rings are normally stored at the road site at the planned location of the culvert. They need to be handled with care, in particular when off-loading to avoid that they break. When ordering culvert rings always order a couple of spare rings in case of breakage.

#### Cement

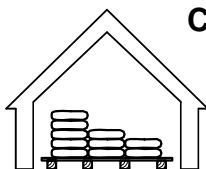

Cement is very expensive, so it must be handled and stored with care. Avoid breaking the sacks when handling and keep it in a dry and flood secure place. Stack the cement bags off the floor. Always use the oldest cement first.

#### Pegs

Wooden pegs for the setting out activities are normally produced on site. They should be made well in advance so that the sites have sufficient supply when they are needed. Production of pegs should be organised under the responsibility of the store keeper. If necessary, an additional person can be hired for the collection of wood and cutting of the pegs.

### 3.4 Maintenance of Equipment

**B**y definition, labour-based road construction and maintenance methods consist of an appropriate combination of labour complemented with a limited use of equipment. Equipment for labour-based road works is mainly utilised for operations such as haulage of materials and water, compaction and rock breaking. Well-designed and maintained equipment is important as they determine the productivity as well as the quality of the works carried out. Malfunctioning equipment is very often the most common item which jeopardises the progress of a road project.

Regular mechanical maintenance of the equipment avoids break downs and ensures a long equipment life time. The site supervisor *must* ensure that the operators are aware of the required maintenance and service of their equipment and that it is carried out at regular intervals.

Each piece of equipment has an Operators Manual which specifies when and where lubrication and adjustments are required. As a rule of the thumb, the following activities should be carried out on a daily basis:



<b>Clean and Check</b>
✓ lubrication oil level
✓ radiator water level
✓ hydraulic oil level
✓ hydraulic hoses and couplings
✓ grease nipples/tracks
✓ battery terminals and battery water
✓ connections from alternator
✓ all the V-belts and their tension
✓ tire pressure/tracks
✓ transmission oil level
✓ brake and clutch fluid level
✓ nuts and bolts of buckets and tracks

With each piece of equipment, there should be a basic set of tools for carrying out preventive maintenance and minor repairs. These tools should be handed to the operator. To minimize any loss, he/she should be held personally responsible for any loss of these tools.

It is the responsibility of the site supervisor to ensure that regular maintenance of all project tools and equipment is carried out.

## 3.5 Site Support Activities

### Drinking Water

**P**eople who are carrying out hard physical work need to drink a lot of water to prevent dehydration. It is therefore important for the workers to have water available on the work site. If there is no drinkable water within the vicinity of their job site, some arrangement should be made to supply and store water for drinking purposes. This normally implies that it is necessary to engage a couple of workers to transport clean water to the work site and the camp.

The amount of drinking water required varies with the weather conditions, but a minimum of 3 litres per person per day should be provided.

### First Aid

Every site should have access to a first aid medical kit. The medical kit should be administered by someone who is properly trained in using its contents.

The first aid kit should be regularly replenished, so it is effective when an accident occurs.

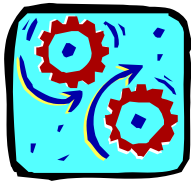

# **Chapter 4**

# **Work Organisation**

---

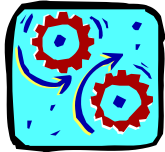

## Chapter 4

# Work Organisation

---

<b>4.1</b>	<b>Definition</b>	<b>78</b>
<b>4.2</b>	<b>Work Programming</b>	<b>78</b>
	Construction Sequence	78
	Site Supervisory Staff	79
	Daily Work Planning	79
	Gang Balancing	79
<b>4.3</b>	<b>Recruitment and Employment of Labour</b>	<b>81</b>
	Recruitment	81
	Incentive Schemes	81
	Daily Paid Work	82
	Task Work	82
	Group Tasks	82
	Piece Work	82
	Payment in Kind	82
	Task Rates	82
<b>4.4</b>	<b>Inspection and Supervision</b>	<b>84</b>
	Control of Works	84

## 4.1 Definition

**W**ork programming is to arrange and distribute the construction works between the gangs of workers in such a way that the best use is made of the available labour, material, tools and equipment. This includes planning the works, taking the following items into account:

- ✓ in which order work operations and activities should follow, the *construction sequence*,
- ✓ the numbers of workers in each group, i.e. gang size and *balancing*,
- ✓ how to motivate the labour, using *incentives*, such as task work, and
- ✓ how instructions are given and received in an efficient manner, avoiding misunderstandings and incorrectly executed works.

## 4.2 Work Programming

### Construction Sequence

Once the site camp has been established and supplied with materials, tools and equipment, the road construction works can commence.

Road construction works are divided into a number of *operations*, each sub-divided into a series of *activities*. The separate operations on a construction site have to follow each other in a logical sequence. The table below gives a general view of the works sequence on a road construction site:

Operation	Activities
Support	work at site camp, setting out alignment
Site Clearing	detailed setting out, bush clearing, grubbing, tree and boulder removal
Earthwork	excavation and filling, spreading and levelling, drainage and camber formation, embankments
Compaction	watering, compacting and final levelling of earth works
Structures	drifts, culverts and small bridges
Gravelling	excavation and transport of gravel, un-loading, spreading, watering and compaction

Normally, each activity is carried out by a separate group of workers. If the activities are too close to each other, the work might be disrupted (e.g. an excavation gang might have to wait for a clearing gang to finish). On the other hand, when activities are spaced too far apart, the length to supervise will become unnecessarily long.



### Remember:

An activity should follow the preceding one as closely as possible without causing interference or over-crowding. The distance between the first and last activity should preferably not exceed 2km.

When commencing on a new project, it is important to stagger the above operations, allowing approximately a week before starting the next operation. This will also allow the supervisor to organise the work properly and give basic instructions and training to the newly recruited labour.

### Site Supervisory Staff

Trained supervisors, responsible for a site, are usually capable of effectively controlling a labour force of 100 to 150 workers. Gangs, formed for the different operations, normally range from 10 to 25 workers, depending on the nature and amount of work to be carried out. Among the workers in each gang, one person should be appointed their leader, the *Gangleader*. This person will receive the work instructions from the site supervisor and hand them on to the workers in his/her gang.

Since each gang will become more and more skilled, the longer they do the same type of job, it is good practice to let the gangs work on the same operation, throughout the period they are employed. In this way, a maximum benefit can be derived from the acquired skills.

### Daily Work Planning

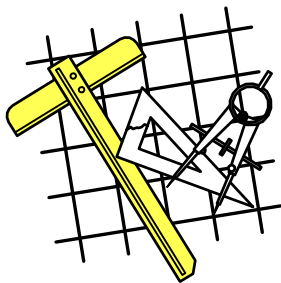

A supervisor must always plan ahead by at least one day. After the workers have completed their daily work, the supervisor records the outputs achieved on each of the activities. Based on the production achieved and the overall plan for the project, a plan for the following day is prepared. This plan sets the daily production targets for each of the planned activities.

To prepare these work plans properly, the supervisor needs to know what has happened on the site before. Without information such as what resources were needed to produce a given output, why certain targets were not met, etc., proper planning is impossible. To get the right information on time, a well functioning reporting system is required.

### Gang Balancing

Balancing of gang sizes, i.e. ensuring that the labour is used in the most efficient way, and that each of the operations on average proceed at the same pace, is the daily task of the site supervisor.

Good gang balancing is important because it also determines the length of the construction site. If the gangs are not well balanced, the result may be that the work site spreads out and becomes too long to supervise in an efficient manner, or that it becomes too concentrated and the workers are working in a small and congested area.

The amount of work will vary along the road line. Therefore there will be a demand for adjusting the number of workers in each gang.

**Example:**

On Section A of a road, there is a lot of bush clearing and very little excavation needs, and on the following Section B there is a small amount of clearing but heavy excavation works. This implies that after clearing and earthworks have been completed on Section A, a number of workers needs to be transferred from the clearing gang to the earthworks gang. If this is not done, the clearing gang will advance too fast and the earthworks operation will proceed too slow on Section B - resulting in a stretched work site which may become difficult to supervise.

Finally, try to avoid that the workers are given too monotonous and straining tasks. Experience has shown that certain tasks such as hand-ramming is difficult for a worker to carry out the entire day. This can be avoided by combining different tasks - for example combining hand-ramming with levelling of excavation works.

## 4.3 Recruitment and Employment of Labour

### Recruitment

**T**he workforce employed to execute labour-based road works are normally locally recruited within the vicinity of the road sites on a daily basis and are paid only for the days they have worked. They are not entitled any social benefits such as paid leave, pensions, sick leave, etc. They can be laid off when their services are no longer required. When the road construction activities are moved to a new area, new workers are recruited from this area.

To facilitate sufficient recruitment of workers, it is important to plan the work well in advance so that the local villagers can be given due notice about the future labour requirements of the project.

In addition, the most labour intensive activities needs to be timed to periods of the year when labour availability is good, i.e. in the agricultural slack season. Try to avoid the sowing and harvesting periods for the activities which require a large number of workers.



#### Remember:

The labour is recruited on a temporary basis, and the local population needs due notice so that they can plan and organise their other obligations (i.e. on the farm or in the household) before they can participate in the road project.

When announcing the employment opportunities in the local villages, it is important to point out that both men *and* women are eligible to apply.

If there is a surplus of labour applying for work, make sure that the recruitment is fair and gives an equal chance for all applicants. Avoid recruiting persons which are under age. During recruitment, it is important that the workers are fully informed about the conditions of work, i.e. working hours, the wage amount and when it will be paid, period of employment and general discipline on the job site.

To ensure the required level of effectiveness on the work site, serious attention must be given to the motivation of the labour force. This is ensured by various measures such as appropriate wages, proper supervision, secure working conditions, timely payment of wages and the use of incentive schemes.

### Incentive Schemes

Payment of works can be organised in various forms, depending on the nature of work and type of funding. It is necessary to investigate which incentives can be used and which systems will be the most effective. Also, the workers have to understand and

support the system which is introduced. If the system is not regarded as fair, the workers will cease to turn up to work.

### **Daily Paid Work**

Daily paid workers are paid a fixed sum for each day in return for a fixed number of working hours regardless of his/her work outputs. This system is often used when starting up a new project before an incentive scheme has been established. It is also used as the basis payment when productivities are low and the limits for the receipt of bonuses are not reached. Finally, this payment system is applied for most site support activities, such as store keeping, the watchman and providing drinking water.

### **Task Work**

Task work is the most commonly used incentive scheme on labour-based projects. Task work implies that the labourer is given a clearly defined amount of work to be completed in one day whereafter he is free to discharge. This incentive is popular among the workers, because it enables them to leave earlier thereby allowing them to tend to other obligations at home during the rest of the day.

### **Group Tasks**

In this system a group of workers are given a certain task which may take several days to complete. The incentive here is that if the group so decides they can work harder and finish in a shorter time but still with the agreed amount of money to take home.

### **Piece Work**

On piece work each individual worker is paid per unit of output. The "pieces" are normally equivalent to one to three times the output expected on daily paid work. Activities such as production of setting out pegs, collection of stone and sharpening tools are best organised as piece work. Piece work can also be set to most activities where task work can be used. However, piece work is more difficult to organise and more complicated to monitor.

### **Payment in Kind**

In areas where food supply is limited, payment in kind may act as an effective incentive. However, there are certain international standards which must be observed when paying with food for work. Unless the Government declares an emergency situation in the area, the food payment should be combined with a certain minimum amount paid in cash.

### **Task Rates**

To be effective and fair, the tasks must be estimated correctly and set out properly. The supervisor therefore needs to know in detail how to set out task work and which task rates to use for the various activities in different circumstances (hard or loose soil, wet or dry soils, thick or sparse bush, etc.).

Task rates or piece rates can be set on most activities. In general, it is better to set a poor task rather than organising the workers on daily paid work. The following activities should always be organised as task work:

- ✓ grass and topsoil removal (grubbing)
- ✓ ditching
- ✓ spreading and camber formation
- ✓ gravelling
- ✓ excavation
- ✓ sloping
- ✓ culvert laying
- ✓ scour checks

It is the responsibility of the site supervisor to calculate and set the task. For this, it is necessary to establish (i) the quantity of works (area, volume or numbers) and (ii) the difficulty of the work (loose or hard soil, etc.)



The correct amount of work one worker has to complete in one day, has to be established by detailed measurements of productivity under various conditions. For this, the daily and weekly reporting system will provide good support for the supervisor. When a new site is established, it may initially be necessary to organise some of the work on a daily paid basis. Based on the productivities during the first couple of weeks, it is possible to establish and refine the task rates on the work site.

A correct set task should allow the average worker to finish their day's work in approximately 75% of the normal working hours.

It is the responsibility of the site supervisor that the workers receive their tasks in the morning immediately when they arrive, and that the amount of work is fair and just. The size of the task must therefore be carefully monitored to ensure that the amount of work given to each worker is neither too little, nor too much. The table below shows some average task rates, however, these should only be used in an initial phase, before more appropriate quantities have been determined through site trials. Once agreed, the workers should stay on site until their task is completed.

Clearing and Grubbing	50 - 150 m <sup>3</sup> /wd	Drain Excavation	1.5 - 3.0 m <sup>3</sup> /wd
Levelling	1.5 - 3.0 m <sup>2</sup> /wd	Camber Formation	75 m <sup>2</sup> /wd
Earth Excavation and up to 20m transport	1.5 - 2.5 m <sup>3</sup> /wd	Turfing	10 - 20 m <sup>2</sup> /wd
Hand Compaction	100 m <sup>2</sup> /wd	Gravelling (spreading and levelling)	5 - 10 m <sup>2</sup> /wd

## 4.4 Inspection and Supervision

 Giving and receiving instructions is a major part of the responsibilities of the site supervisor. The manner in which instructions are given influence the manner in which they will be carried out. Before you give instructions, it is important to specifically know:

- ✓ what work you want to have done,
- ✓ how it should be carried out,
- ✓ who will do it, and
- ✓ the difficulties involved in doing it.

Instructions can be given either directly to the person who will carry out the work, or indirectly through a gangleader. Direct instructions to all concerned workers including their gangleader should be used as much as possible. Indirect instructions can be given through a gangleader when he/she as well as the workers are familiar with the task and the work methods. Ask questions to check that your instructions have been understood.

If the task is not familiar, careful attention must be given to explaining the work in detail to the entire gang. In many cases, it would be useful for the supervisor to actually demonstrate the work and how it is properly done.

When you receive instructions, repeat them to yourself, and ask for clarification if something is unclear. Then repeat the instructions to the person who gave them to ensure that there are no misunderstandings.

Whenever practical, instructions should be given in writing or written down when received. This applies in particular to instructions concerning measurements and technical designs.

### Control of Works

The supervisor needs to inspect and approve the work before the workers are released for the day. He/she should be notified by the gang leader, who informs him/her that a particular task has been completed and is ready for inspection.

When inspecting completed works, check that:

- ✓ The set-out measurements have been kept correctly
- ✓ The edges are straight and well trimmed,
- ✓ The soil is placed correctly, and
- ✓ All the work as defined in the task is completed.

If the work has been satisfactorily completed, the group or individual may be released for the day. If the work is not complete, it should be corrected before the group or individual worker is allowed to leave the site.

If the task is not completed before the end of the normal working day, the supervisor needs to find out the cause of the delay - whether the cause lies with the workers or with his/her own setting of the task. If

the reason for non-completion is one of the following, the workers should be released:

- major difficulties not considered when the task was set (i.e. heavy roots, big rocks, etc.),
- incorrect measurement or calculation of the task,
- smaller work force than ordered (if a group task was set),
- bad weather conditions during parts of the day.

If the reason for non-completion lies with the workers, they should complete the task before being released, even if it is after the end of the normal working day.



**Remember:**

The workers should only be registered in the muster-roll when they have fully completed their daily tasks.

If necessary, the workers may return to the work site the following day to complete their task.

# Annex 1

## References

---

Guide to the Training of Supervisors for Labour-based Road Construction and Maintenance, *Karlsson and de Veen*, ILO, 1981

Building Roads by Hand, *Antoniou, Guthrie and de Veen*, ILO 1990

Design Guidelines for Low Volume Roads Suitable for Labour-based Construction Methods, Ministry of Works, Lesotho 1991

Introductory Training Course in Labour-based Roads Construction for Engineers and Technicians, *Marshall*, ILO Cambodia, 1993

Labor-based Construction Programs: A Practical Guide for Planning and Management, *Coukis et al*, World Bank, 1983

Rehabilitation of Feeder Roads Using Labour-based Methods, Technical Manual, *Veselinovic*, UNOPS, Afghanistan, 1993

Technical Manual, *Marshall*, District Council Road Unit, Botswana 1987

Technical Manual for Low Volume Roads Upgraded and Constructed Using Labour-based Methods in Lesotho, Ministry of Works, Lesotho 1992

Training Videos for Labour-based Road Construction and Maintenance, ILO 1991

Field Manual for Labour-based Road Supervisors, *Johannessen*, ILO Cambodia, 1994

Course Notes, Roads - Labour-based Methods, *Strom*, Field Training Unit, Botswana 1994

Introductory Course in Labour-based Roads Construction for Engineers and Technicians, *Roads Training Centre*, ILO Laos, 1995

Road Maintenance and Regravelling (ROMAR) using Labour-based Methods, *Andersson, Beusch and Miles*, ILO 1996