

WRAPPING LANDSCAPE :

VIRGINIA POLYTECHNIC INSTITUTE AND STATE UNIVERSITY GOLF CLUBHOUSE



AUTHOR: ROBERT SIKORSKI

WRAPPING LANDSCAPE :

VIRGINIA POLYTECHNIC INSTITUTE AND STATE UNIVERSITY GOLF CLUBHOUSE

AUTHOR: ROBERT SIKORSKI

Thesis submitted to the faculty of Virginia Polytechnic Institute and State University in partial fulfillment of the requirements for the degree of

MASTER OF ARCHITECTURE

May 12, 2006
Blacksburg, Virginia

Committee Chairman, Steve Thompson

Committee Member, Bill Galloway

Committee Member, Hans Rott

Keywords: Wrapping, Landscape, Clubhouse

WRAPPING LANDSCAPE :

VIRGINIA POLYTECHNIC INSTITUTE AND STATE UNIVERSITY GOLF CLUBHOUSE

AUTHOR: ROBERT SIKORSKI

ABSTRACT

The focus of my thesis is to create an architectural wrap through a development of layers in a system. This investigation starts with the design of a golf clubhouse on the Virginia Polytechnic Institute and State University.

ACKNOWLEDGMENTS

I would like to thank Heiner Schnoedt for being my chair at the beginning of my thesis, because of his persistence I was able to get a great start, and finish to my thesis. Without his constructive criticism I wouldn't be here today.

I would like to thank Steve Thompson for really stepping in as my chair while Heiner was in Europe. I feel that his philosophy about architecture really helped me to sort out my thoughts when some of my ideas went off the path.

I want to thank Bill Galloway for being a real guidance to me and my thesis, especially in my structural aspirations of the project. When I felt that structure was going to make or break my project, Bill really helped and motivated me to pull it through.

Last but not least, I would like to thank Hans Rott. I felt I needed more guidance in my thesis, and Hans was a great help while Heiner was absent. His strong criticism, and leadership gave me motivation to look beyond the normal realms of architecture, which made me strive for great moments.

Again, thank the committee. I feel that everyone that helped me was a chairman.

TABLE OF CONTENTS

INTRODUCTION.....	1
CONCEPTS.....	2
SITE DEVELOPMENT.....	4
BUILDING DEVELOPMENT.....	7
STRUCTURE.....	12
FLOOR PLANS.....	25
SECTIONS.....	28
ELEVATIONS.....	32
CONCLUSION.....	36
BIBLIOGRAPHY.....	37
APPENDIX.....	38
VITAE.....	43

INTRODUCTION

The beginnings of this thesis project start with the idea of an installation into the landscape, but not just any installation of architecture, but the study of how an installation can consist of many layers to spark curiosity, and excitement within the landscape. The motivation for this idea was inspired by the studies of a famous artist, "Christo."

Christo believed in the idea that by highlighting the landscape, it would make the viewer notice the landscape again in a way that was once taken for granted. By highlighting the landscape with the idea of an installation, Christo arouses curiosity by blocking out parts of the landscape, and reveals what he wants you to see. The material becomes important because of the the different qualities it creates in the hiding and revealing of the object.

One of the installations Christo creates was called, "wrapped trees" (*See Appendix for Reference*). This project was intriguing to me because of the idea of architecture becoming a crucial part to the landscape. More important, how architecture can be wrapped, and act as a foreground for landscape. The main idea being that the landscape becomes a complementary background to the architecture.

Christo developed his ideas further by wrapping urban environment (*See Appendix for Reference*), which inspired ideas of how a wrap can effect more than nature. It effects the scene dramatically, as well as the people viewing it, but mainly the landscape around it. The city becomes the back drop for the many layers of the city. Material becomes important again because of the industrious material Christo uses, which is a dreary canvas that finds life in a natural landscape because of the idea of hiding and revealing.

Christo began his studies of hiding and revealing with the comparison to a package. Christo believed there are three types of packages, which are clothing as a package, transportation as a package, and architecture as a package. The ideas behind clothing being a package is eroticism, in the thought of hiding and revealing to spark arousal. A Transportation package is conceived of the packages one receives today. The ideas of wanting to know what is behind the wrapping, what is on the wrapping or the surprise of the package, which all induces curiosity. The Architectural package creates an architectural wrap materialistically, and at a larger scale. Like Christo I will be taking the ideas of layers, wrap and package to create an architectural wrap that will engage with it's environment to spark aesthetic curiosity.

CONCEPTS

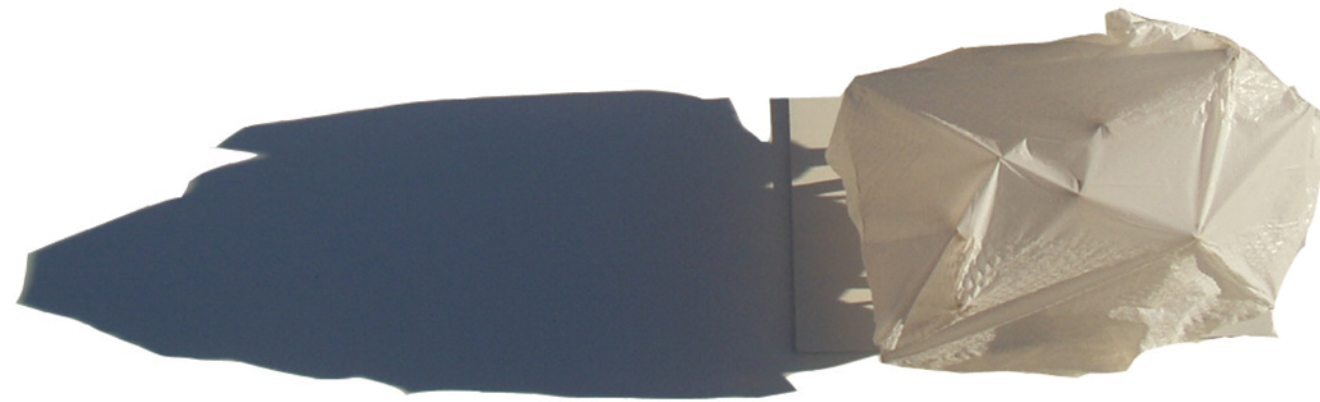
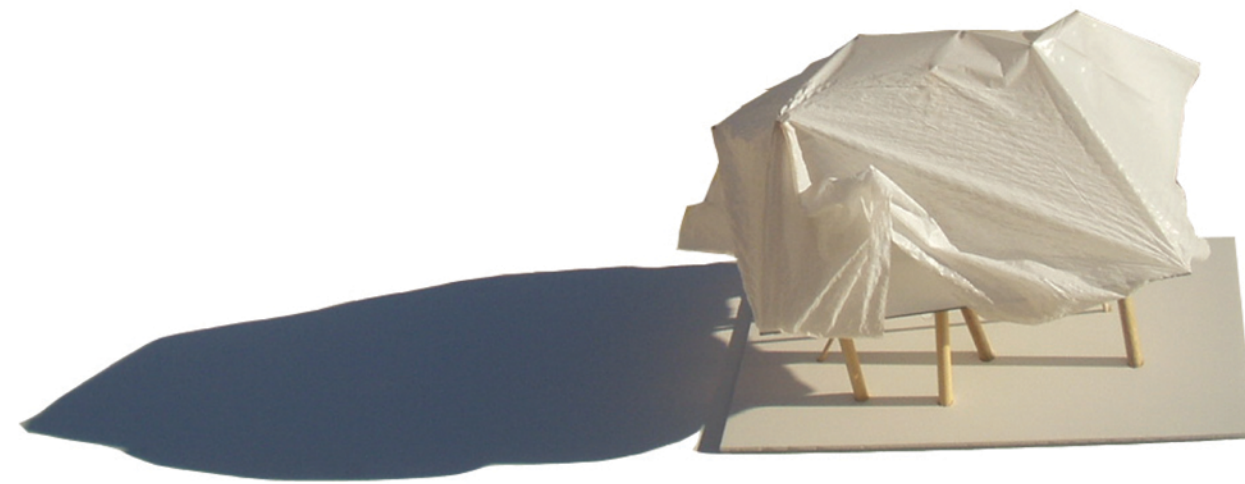
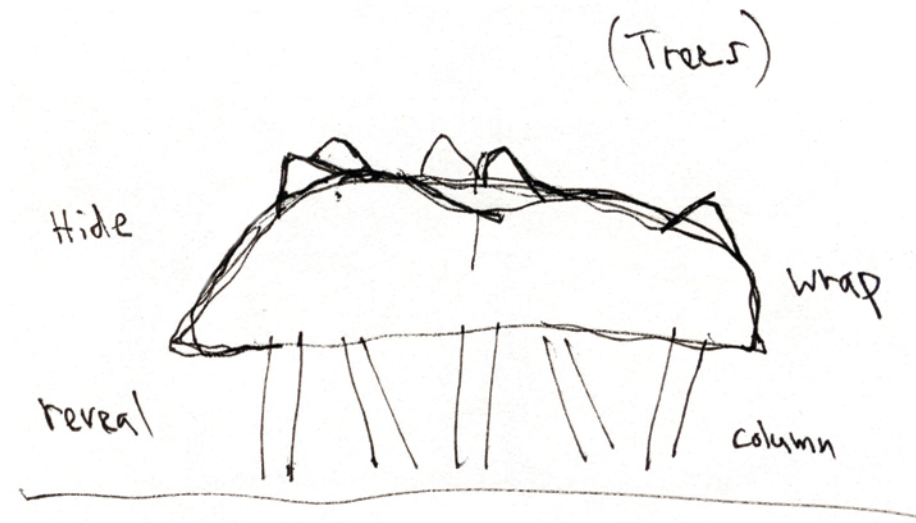

After observing the moves of Christo I decided to create my own architecture. When I thought about my own wrap I thought of the idea of an architecture that would blend in with the trees, or float above with the trees like a treehouse. As you can see in the concept model there is a wrap amongst many wood-like columns that protrude through this wrapping. I thought one could live among this wrap that is floating, which would be supported by these trunk-like columns. In essence, the tree was becoming the main concept for my design. The question was, "How does the tree become a wrap?"

PRINTED TREE SCREEN AS CUTOUT

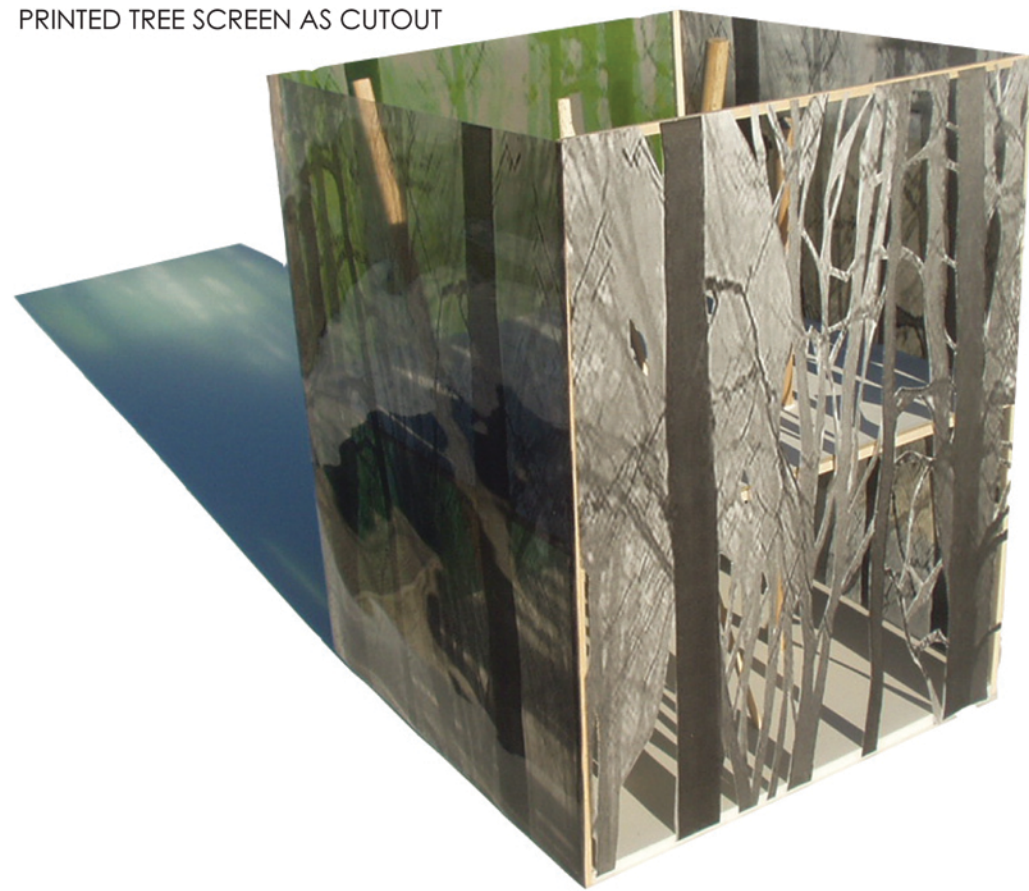

GREEN TREE SCREEN



TREE SCREEN SILHOUETTES



Since the tree in my previous concept model was now the focus, I decided that the idea needed to become more literal and clear. So the next step became to let the image of tree be printed directly onto the wrap. The different layers this forest created had become endless, not only to the ideas of layers, but the ideas of light. The true idea now became how the wrap became a forest of layers, and now created a screen or shade for my architecture.

SITE DEVELOPMENT

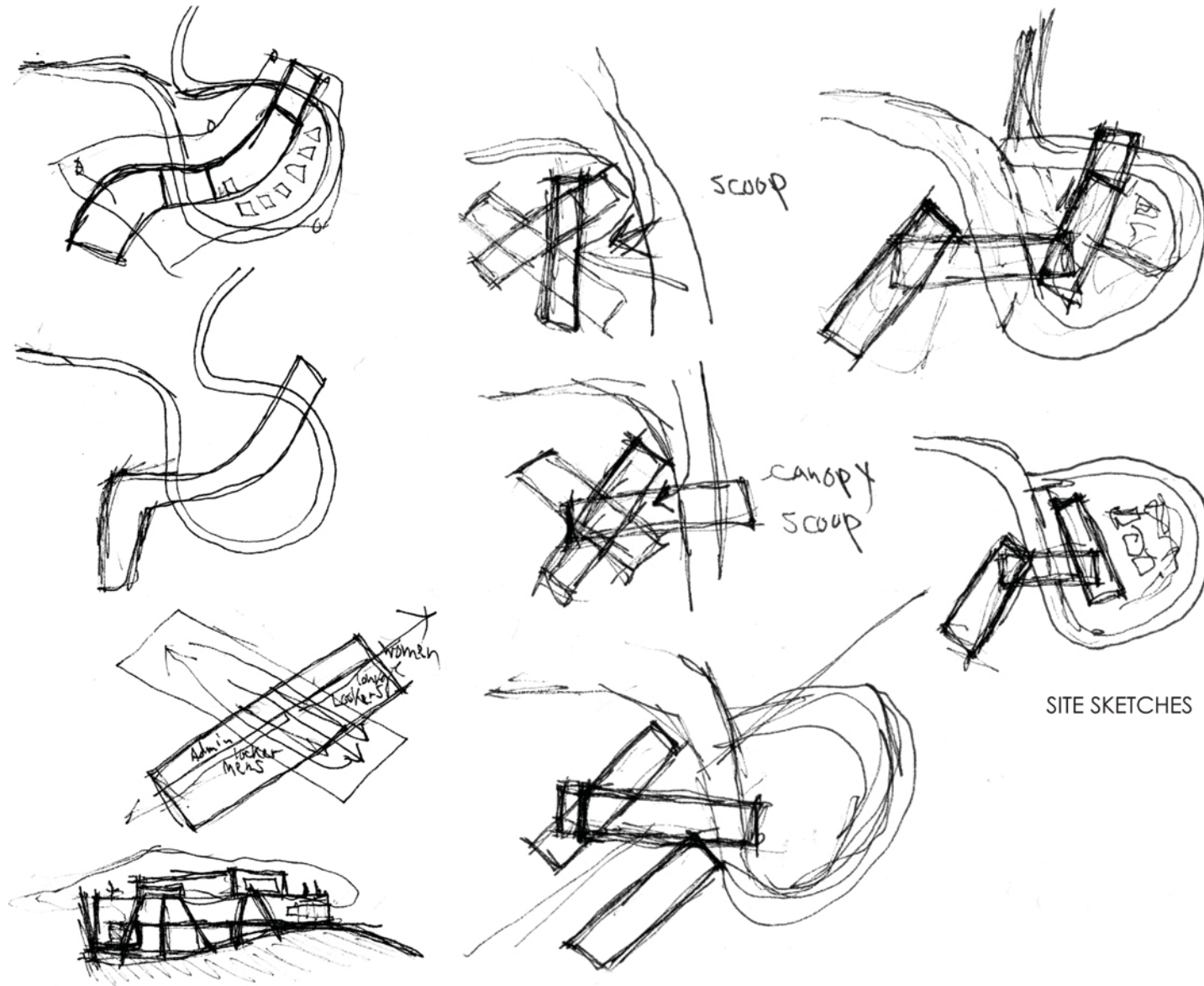

SITE SKETCHES

Site development becomes crucial in the design of the orientation of my building. I knew that my program would be a golf clubhouse. For my program I knew I needed enough space for lockers, lounges, restaurant, service space, atrium, and proshop. There were three clear programmatic spaces, which consisted of the proshop, changing rooms, and restaurant. By dividing these program ideas into two buildings I could fulfill program space requirements. The orientation was now being thought out as two spaces. This brought up the question, how would the building be on the site. I decided orientations were set on how they would relate to other buildings, views, and sun orientation.

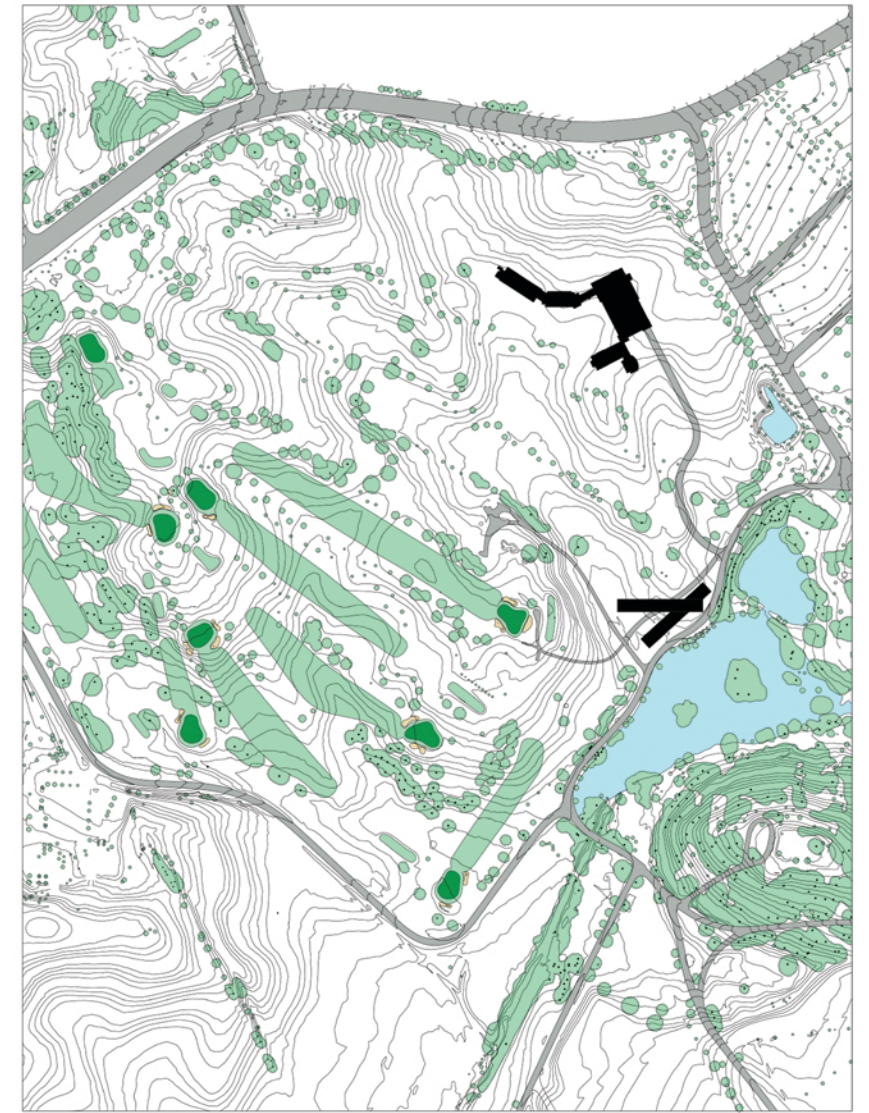

BUILDING FOOTPRINT

Building site location - Blacksbug, VA Virginia Tech. Golf Course.

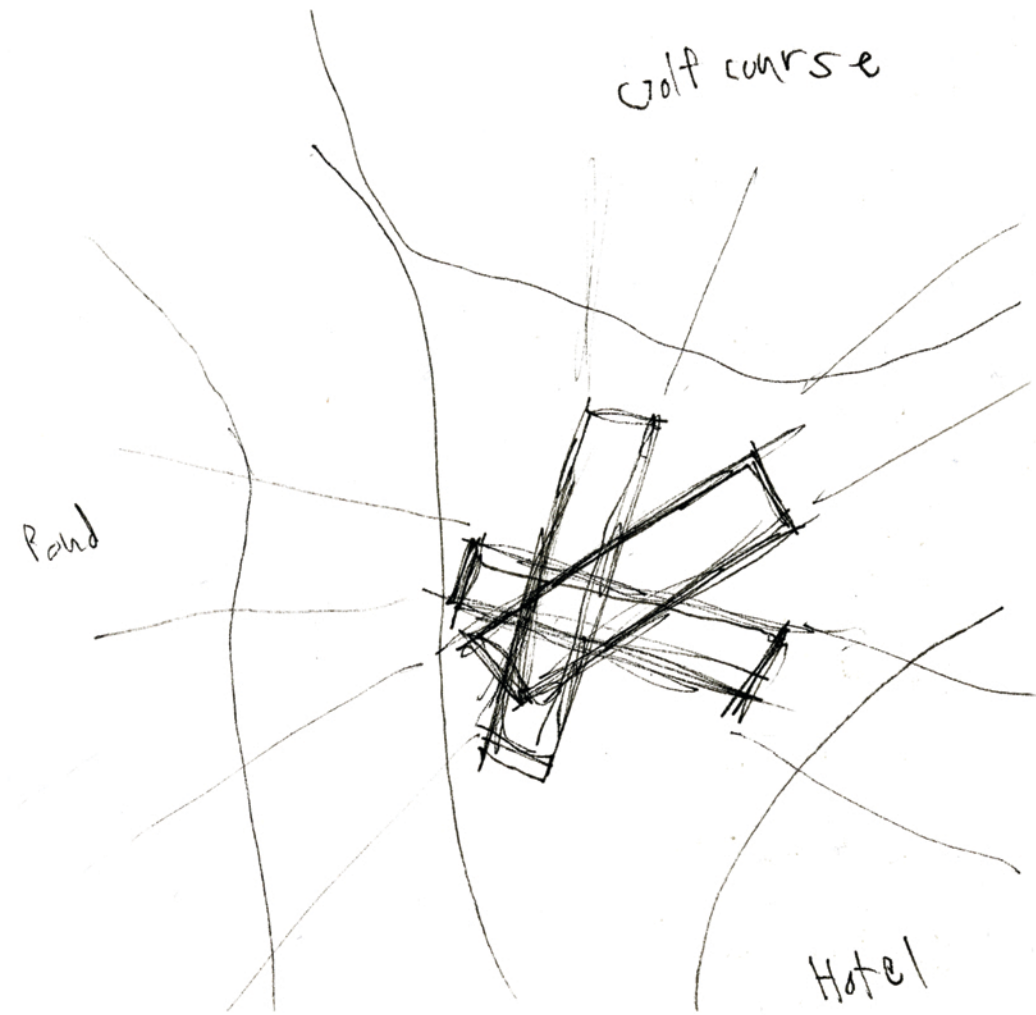

SITE SKETCH

From the beginning stages of my work I thought about orientation on the site by evaluating what views were important, and how the building would be orientated for people viewing the building. As you can see in the site diagram and the site sketch there is an importance in the viewing of the golf pond, and the viewing of the golf course. The orientation is set by the building running parallel to the road axis and the second building would be oriented to the golf course. By setting up the second building in view to the golf course it opened the opportunity to link the Holtzman Alumni Center to my clubhouse. The vision of Hotel and Clubhouse working together was important in the orientation of my building.

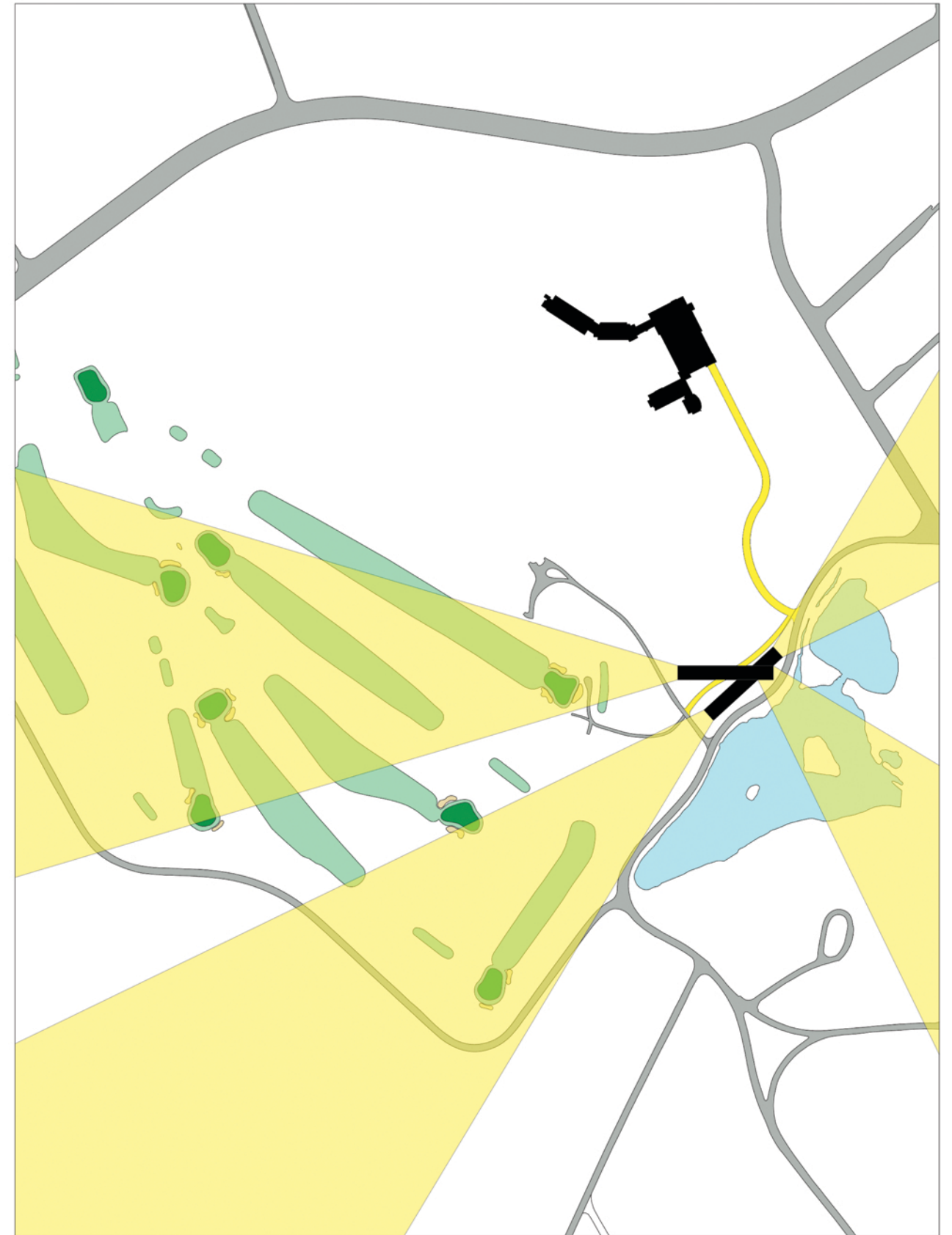

SITE ORIENTATION

SITE SKETCH

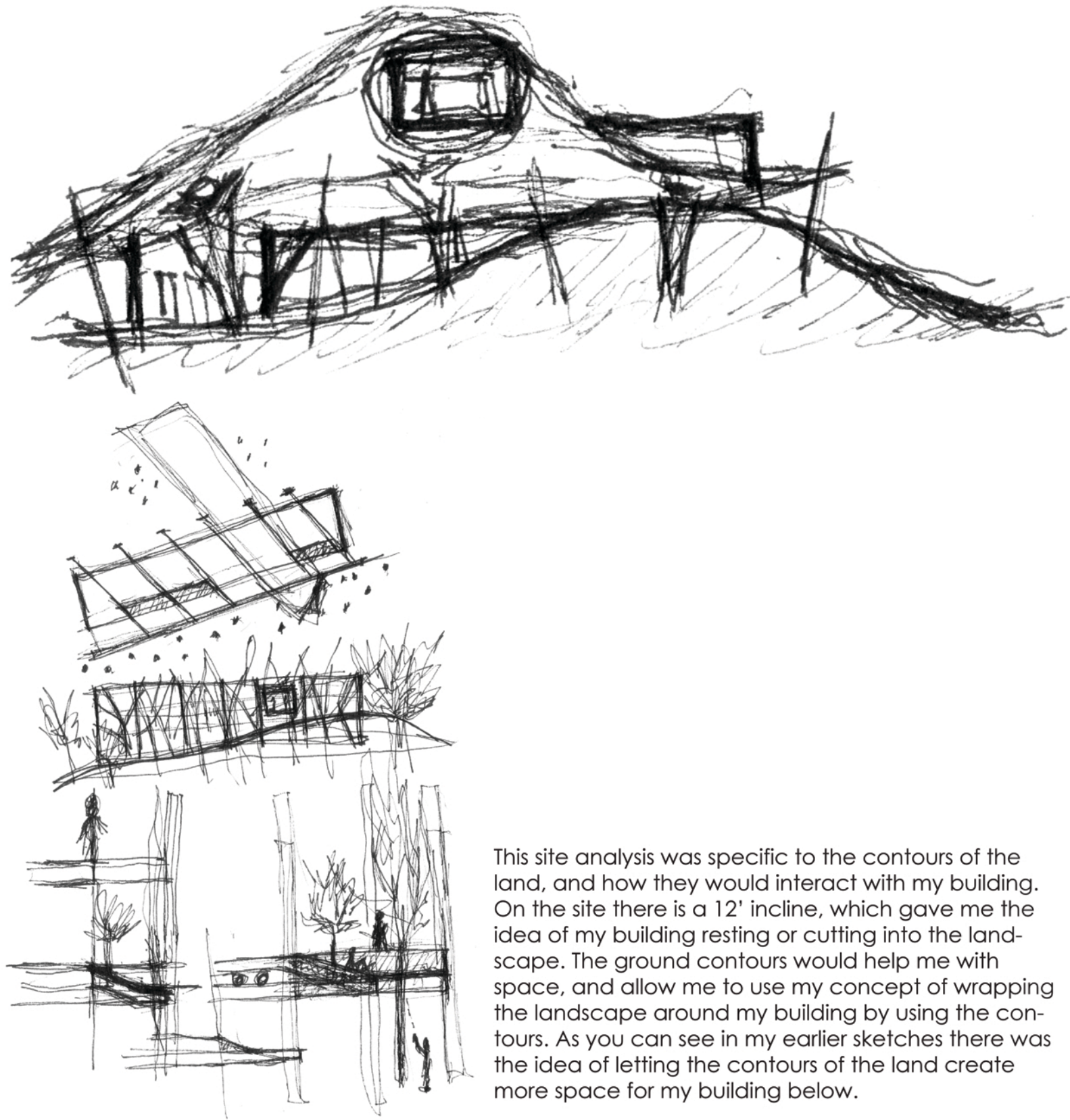

This site analysis was specific to the contours of the land, and how they would interact with my building. On the site there is a 12' incline, which gave me the idea of my building resting or cutting into the landscape. The ground contours would help me with space, and allow me to use my concept of wrapping the landscape around my building by using the contours. As you can see in my earlier sketches there was the idea of letting the contours of the land create more space for my building below.

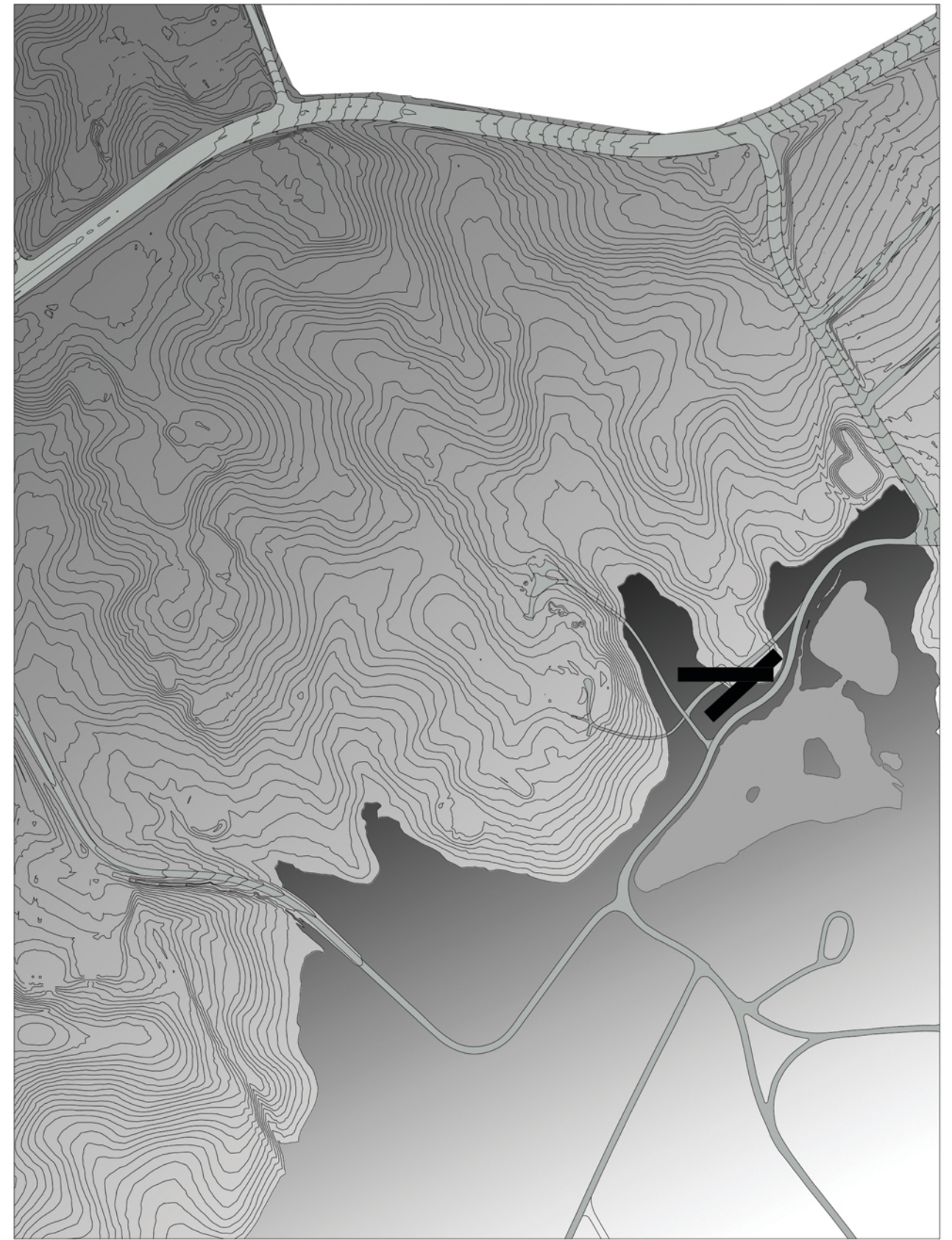

SITE CONTOURS

BUILDING DEVELOPMENT

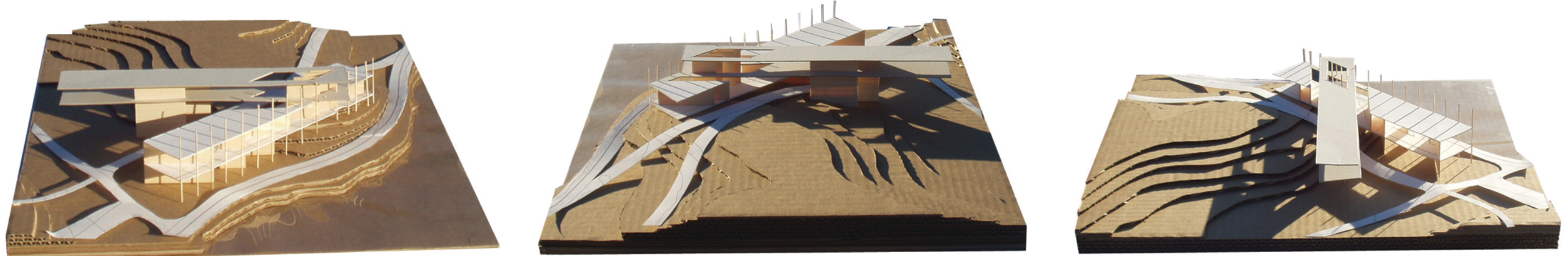

SITE MODELS

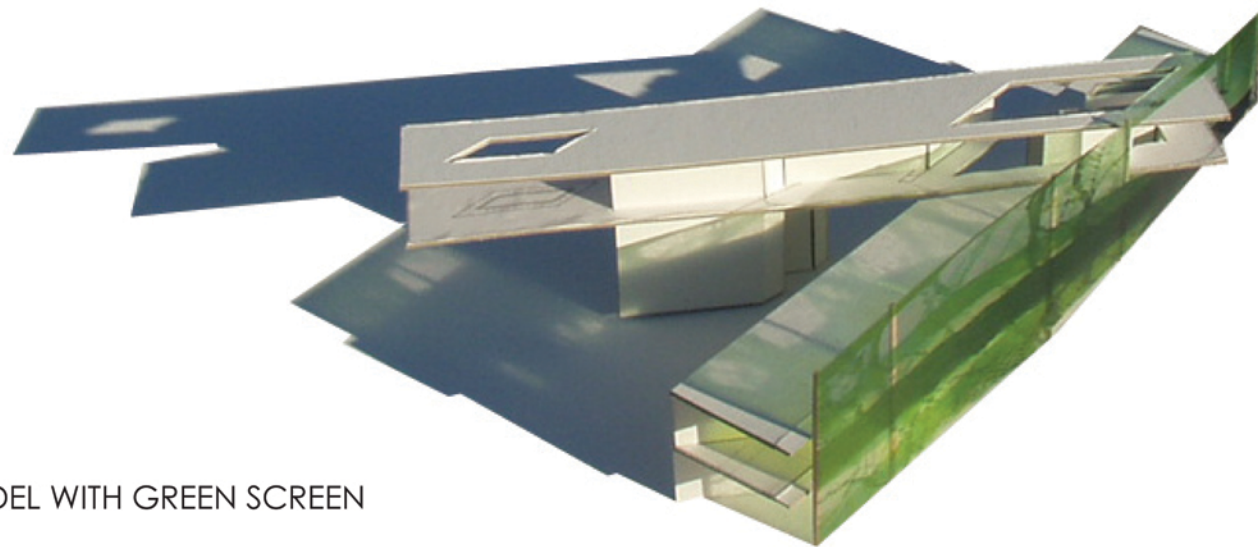

BUILDING MODEL WITH GREEN SCREEN

I knew how the building was going to be oriented, and I knew the parts of the building, but I needed to make it physical. I achieved this by making a model of the spaces I needed, and combining my concept in the design as well. The site models show how the building will leave its footprint on the site, and the ideas of how the building will be built. I differentiated the materials in the models to show how there would be different structural ideas within the model. The design of the building consisted of two parts which fuse together at a common atrium. Also, where the buildings meet I wanted to show that the buildings would have separate identities, so I cut away from the clubhouse to accentuate the cantilever. The cantilevered building would be a floating building amongst the sky and the trees, where the ground building would be the trunk to the rest of the building. The trunk or first and second floors would be the anchor to the grand cantilever that would be branching out into the landscape. With these ideas in mind I could analyze the physical models, and see what means I would have to achieve in order to create a building and more importantly an architectural screen.

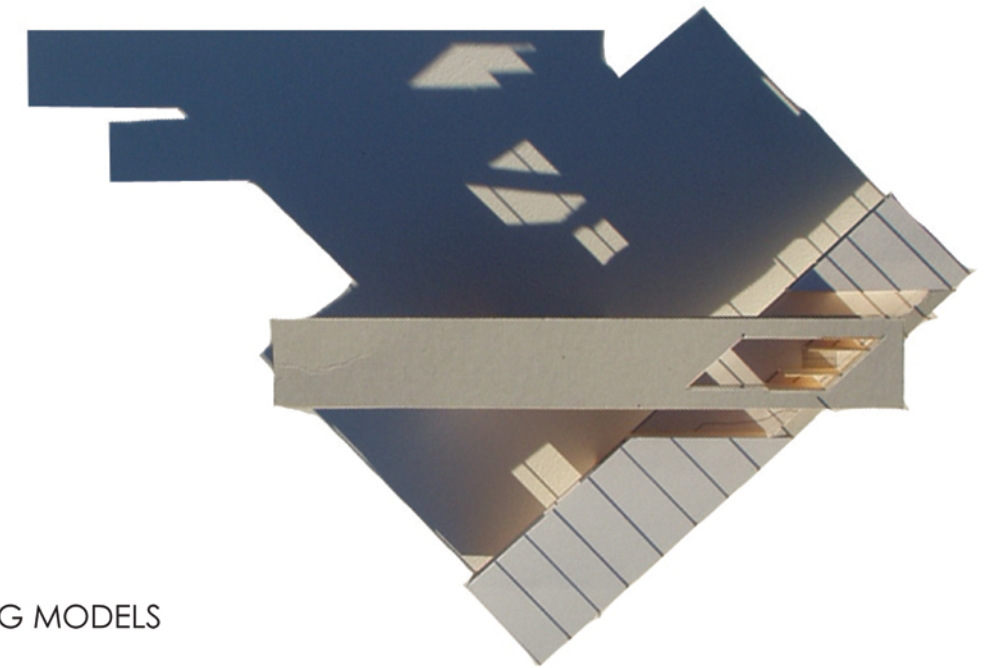

BUILDING MODELS

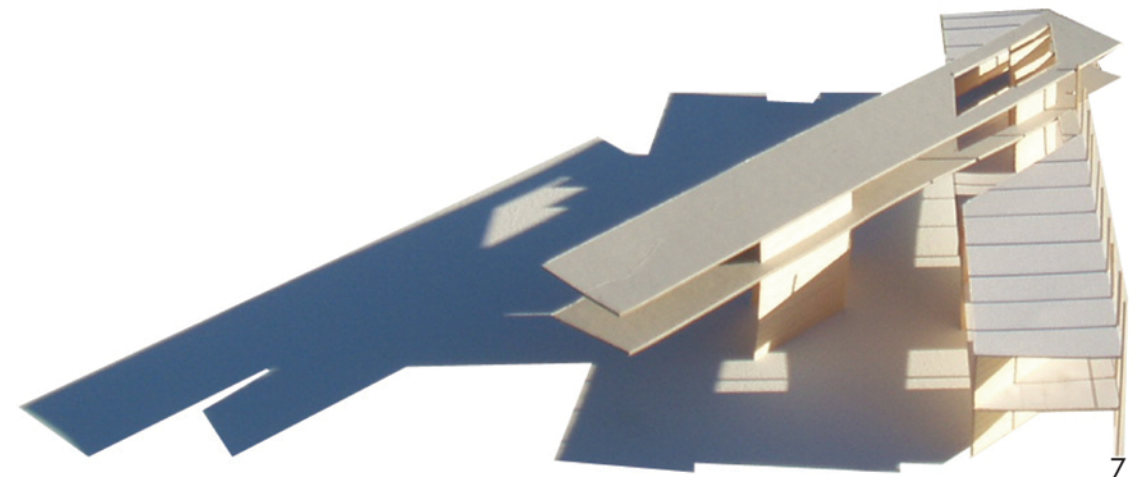

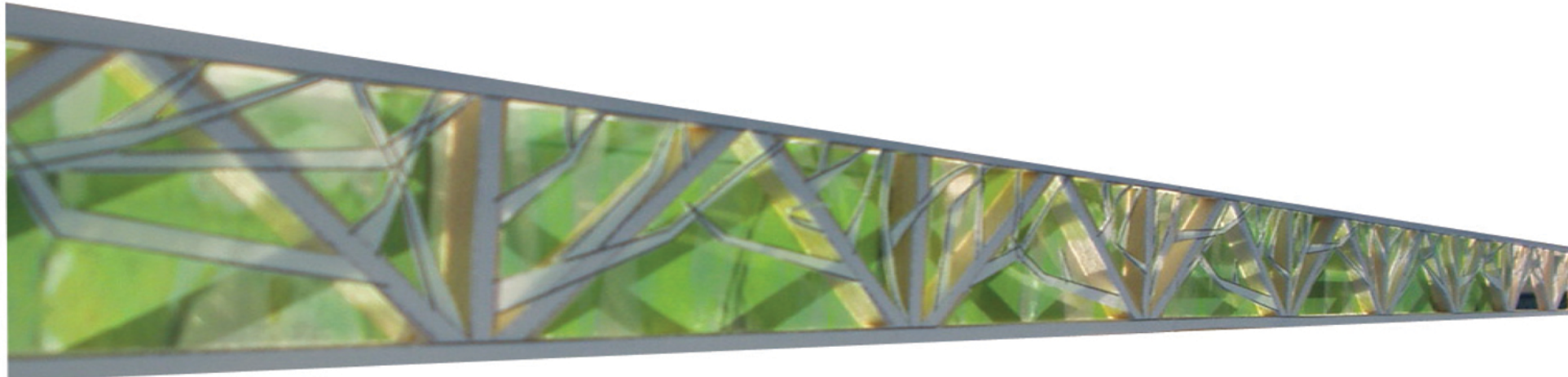

STRUCTURAL LAYERS

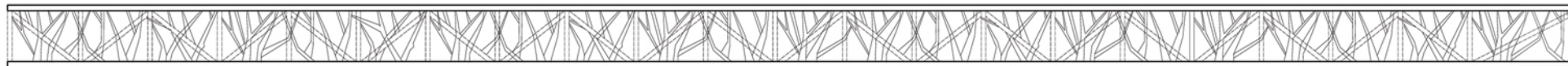

STRUCTURAL TRUSSES

The physical building model I created began to suggest the question of how were my ideas going to become reality? When I had thought of the layers of the screen I was going to create with this printed glass or screen, I started thinking of how I could create multiple layers like a forest. I also thought that with more depth I could create more layers. When I thought of my cantilever, it began to speak to the depth in layers I was thinking of. The depth of the truss I had to create for the cantilever was going to be where I started in creating my wrap. The ideas I had for my truss were trying to create different lattice work that might work around the truss, which would create a forest of structure that would support this 75 ft. span. The layers in this initial model consisted of a interior glass layer of my printed image, the truss layer, and the lattice work on the outside. The language was speaking of the different colors and shadows of trees, as well as the branches of trees, but I asked myself, is this the best way to create this forest of layers, and is this method too complicated?

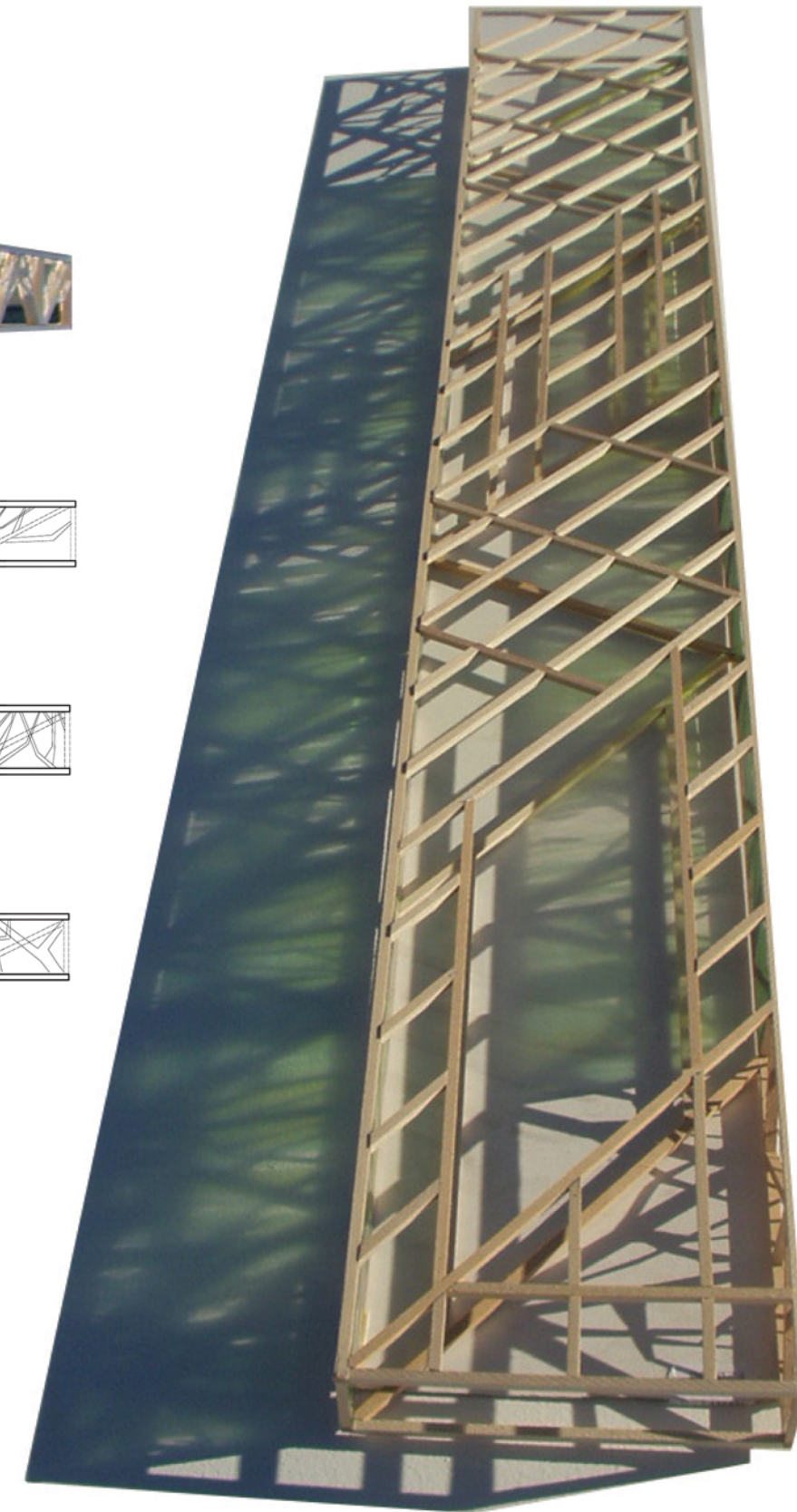

STRUCTURAL MODEL

With the previous design I felt that the layers were right, but the language was not speaking with each other in the sense of they were all separate in an architectural system. The idea was coherent, but not as clear as it could be so I explored further.

The images to the right were from the second iteration that I attempted. As you can see the layers had changed to a structure with perforated metal, which had the printed forest screen. The truss members were 2 ft. thick wide flange steel, and the interior glass became clear with structural mullions. When you look at the section you can see the structure that was added to the box that holds up the perforated metal, and you can see that the printed image was brought to the outside. I thought that maybe the image should not be printed so much, but printed every so often for viewing out to the landscape. There was also a system on the roof of perforated metal that would give a nice light quality to the skylights just below.

After analyzing the second iteration, I began to think that the system was becoming too complicated, and it was going away from the initial design model I had created. I had created more structure that I didn't need. The members in the truss were massive, which I felt were taking away from the wrap. Also the interior glass layer was becoming more complicated with the different structural mullions I created, because the mullions weren't speaking the same language of the system. After this iteration I thought to myself that I needed to take a step back, and look at what was the main purpose of the project, which was to create an architectural wrap, not an architectural structure.

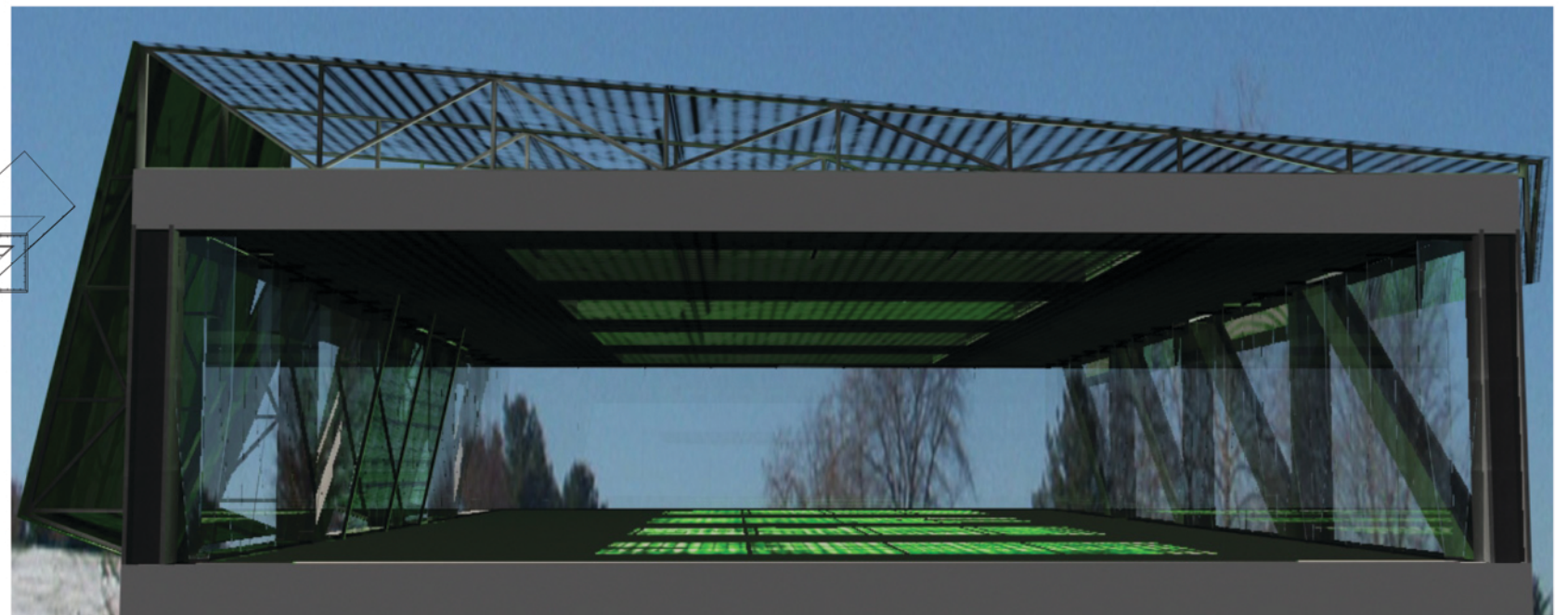
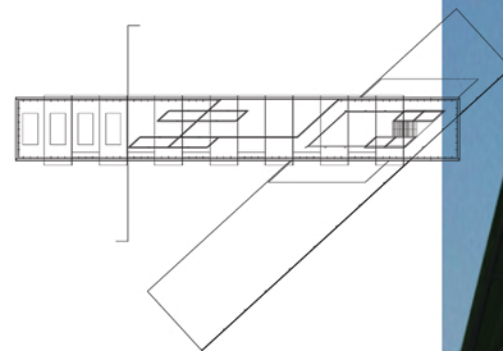
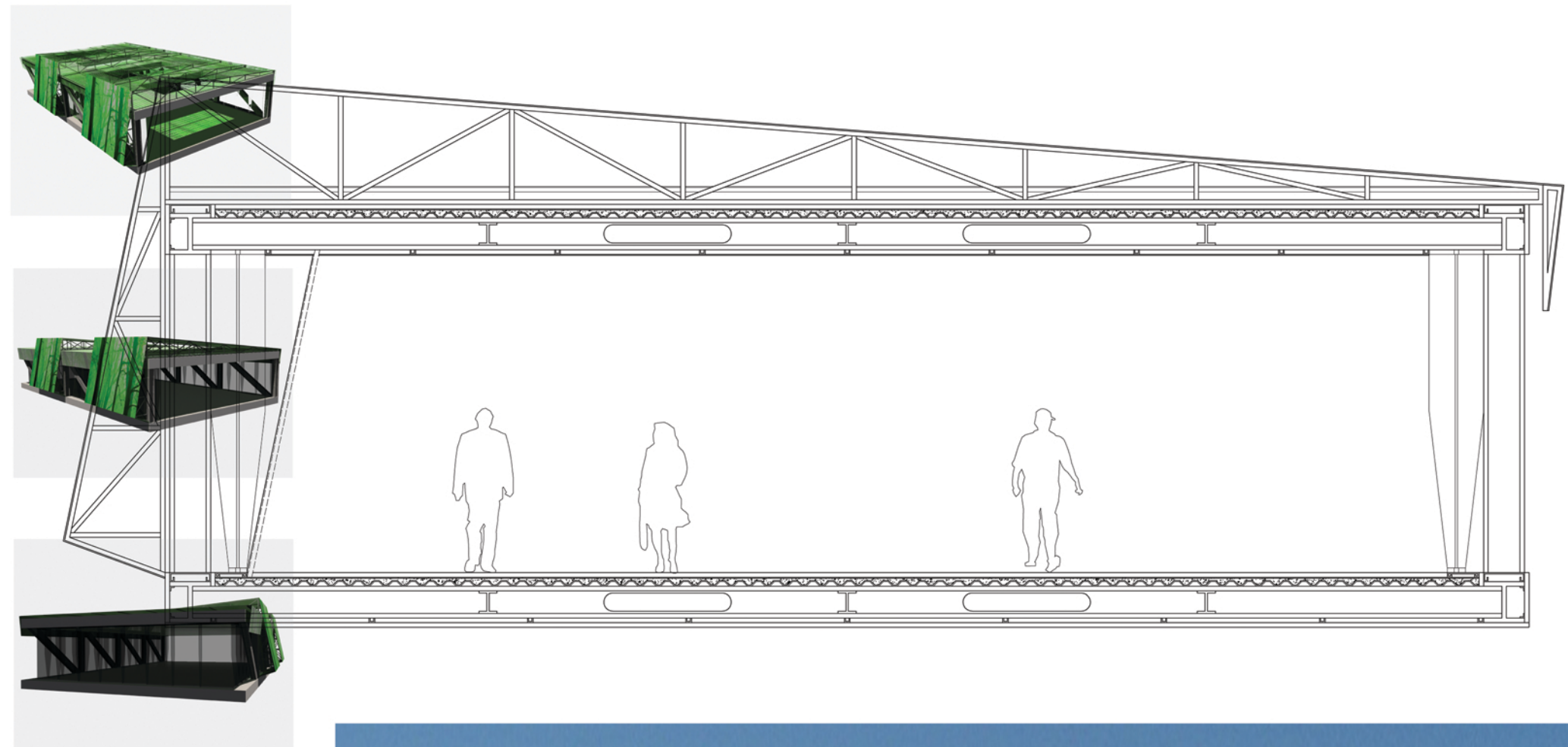

Continuation of second iteration.



GOLF CLUBHOUSE

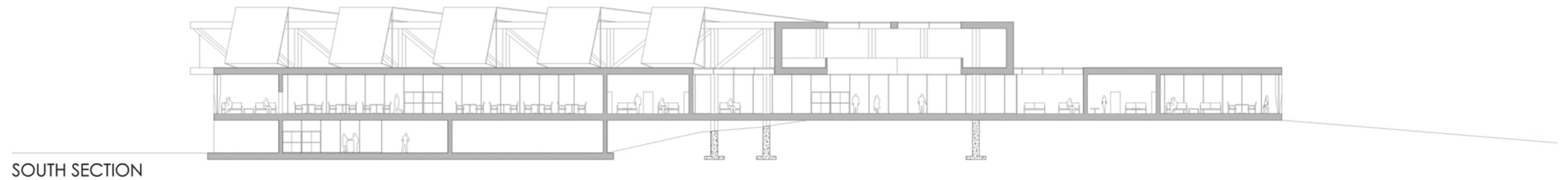

SOUTH SECTION

You can see that the screens are spaced throughout the cantilever, and are giving clear views to the golf course.

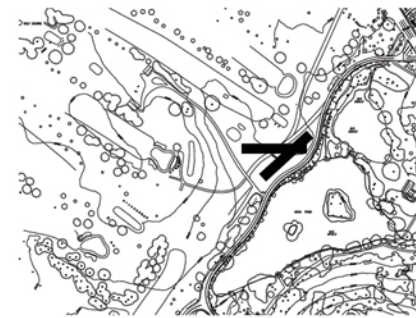

SITE PLAN

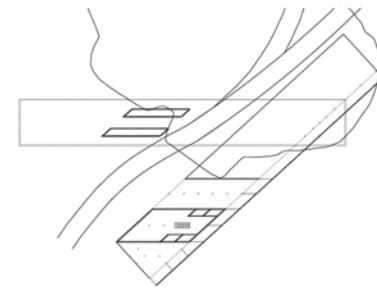

GROUND PLAN

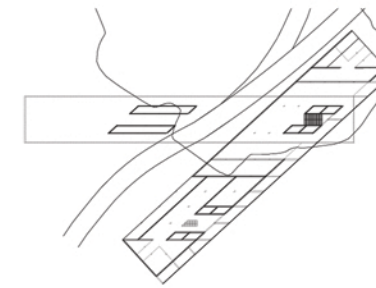

1ST FLOOR

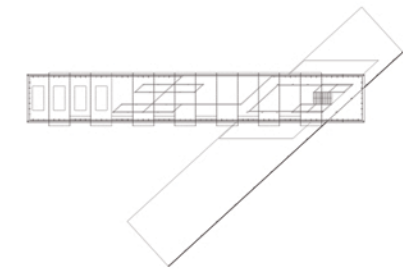

2ND FLOOR

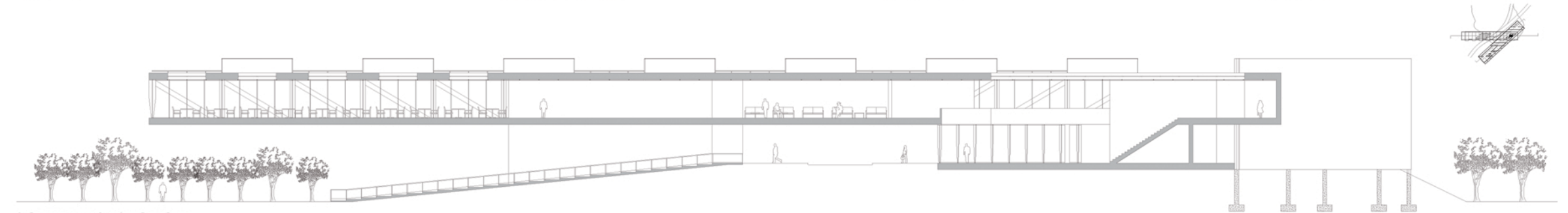

SOUTHWEST SECTION

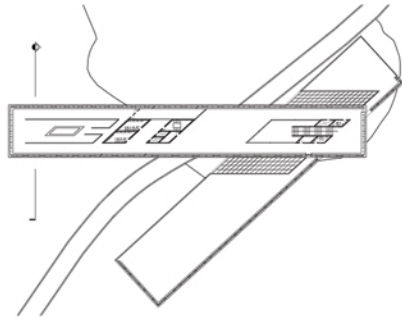

After exploring the different iterations of layers, and architectural systems, I decided to take my ideas and make them more clear. The goal was to create an architectural screen with a printed image, and create many layers to hide and reveal different parts of the building. I thought a more accurate system would be a double envelope. I thought of the double envelope because of the two layers of glass it would create, and these two layers would create a depth for my printed layers. This system I thought perfect for the idea of a forest creating multiple layers.

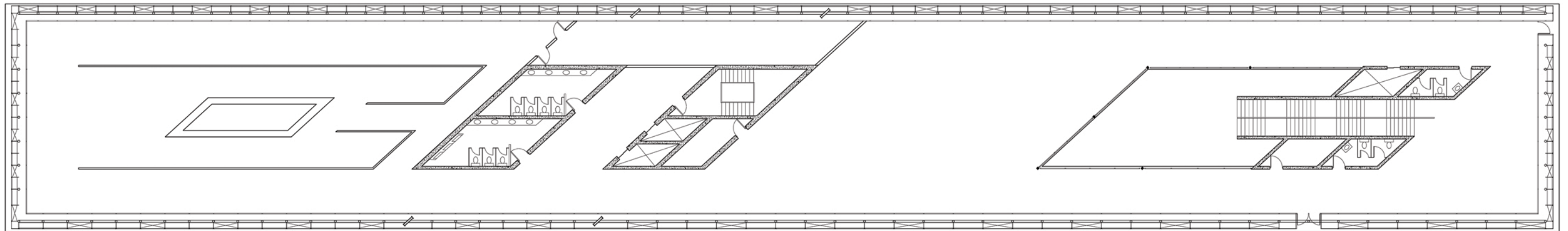

THIRD FLOOR DOUBLE ENVELOPE

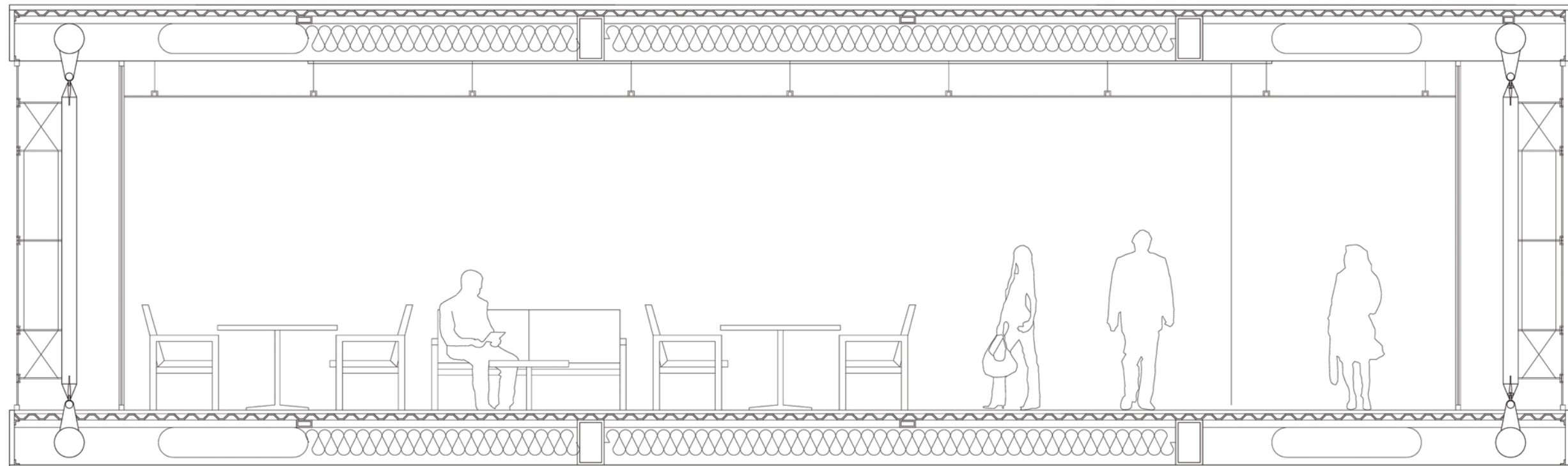

THIRD FLOOR SECTION

STRUCTURE

When I thought of structure I was trying to keep my original design intent. Like before, I wanted to keep the cantilever weightless, and floating. I believed that by making the members less bulky, more slender, and more intricate that I could create this floating feel.

The double envelope system gave me the opportunity to put the truss between the two layers of glass, which would control the temperatures of the truss, and not create a thermal bridge. The truss would also be the structure for the glass. The truss would have spandrels or spider joints that would attach to the glass, where the glass would be butted together and sealed with a thin silicon bead. The spandrels would then be put in tension with cables that would help with lateral support. As you can see in the section the truss would be connected to wide flange steel beams, with a pinned connection. These pinned connections would then connect to slender round columns, which would be trussed across the entire cantilever.

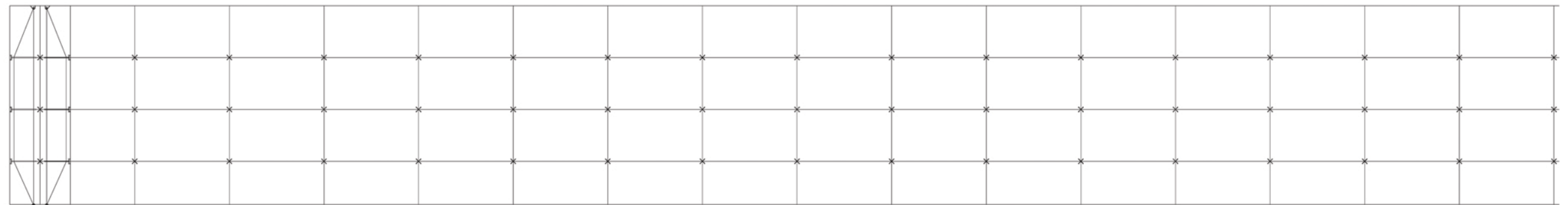
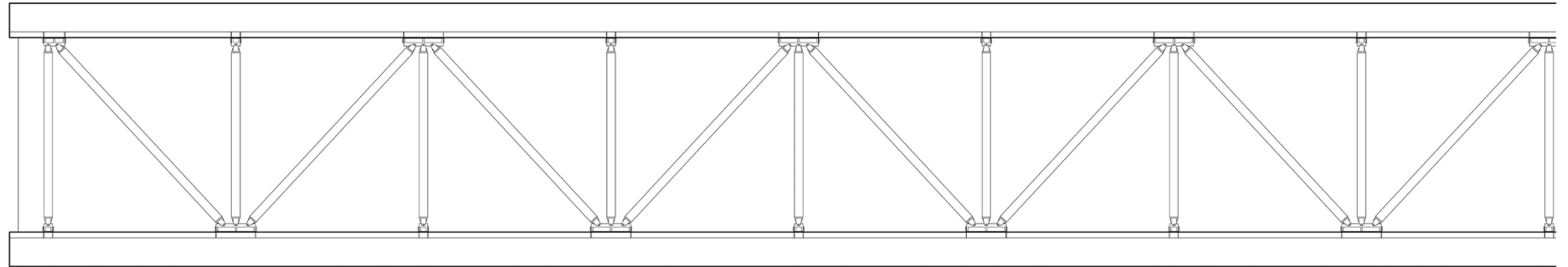

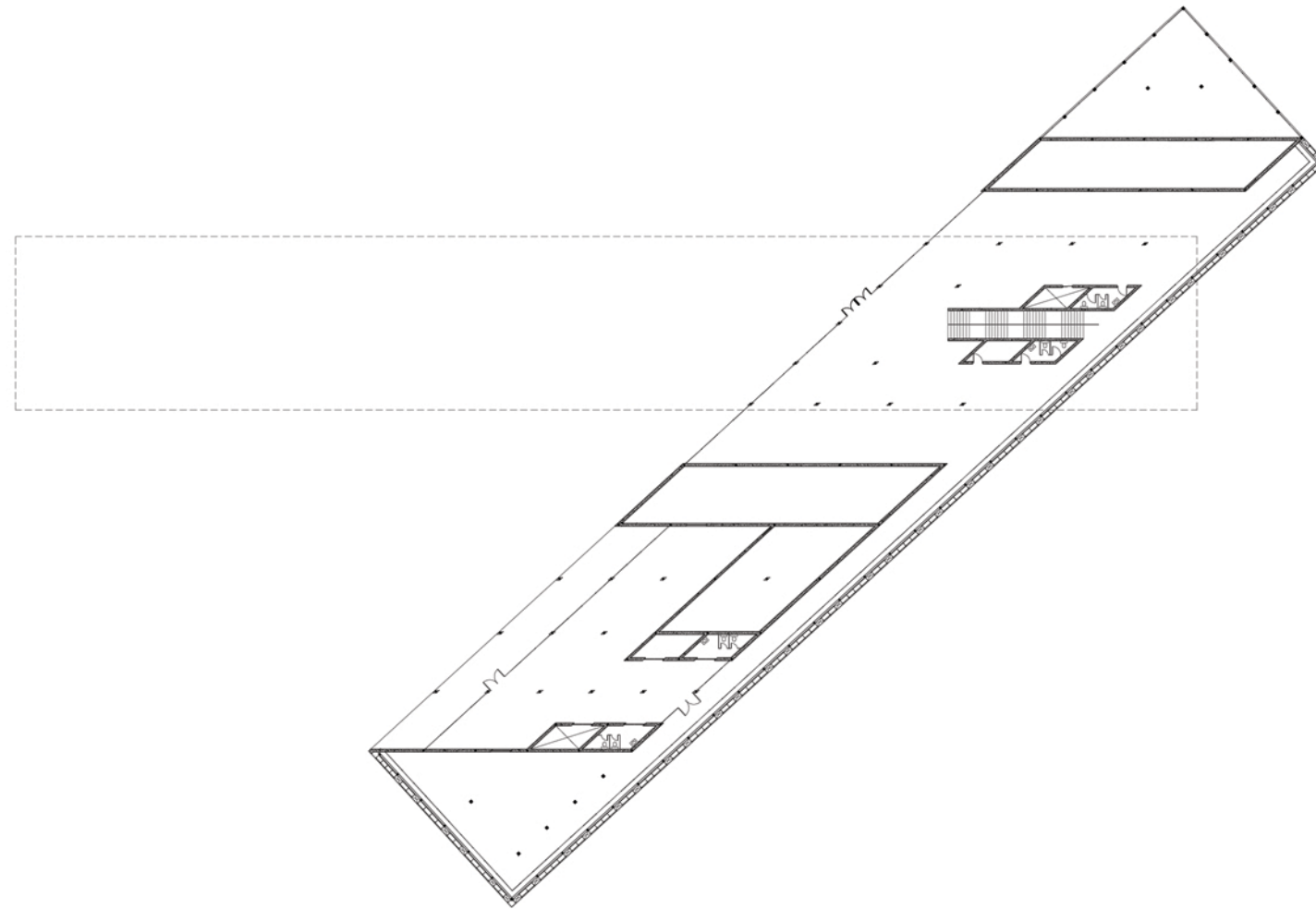

SECOND FLOOR GREEN SCREEN

PINNED CONNECTIONS

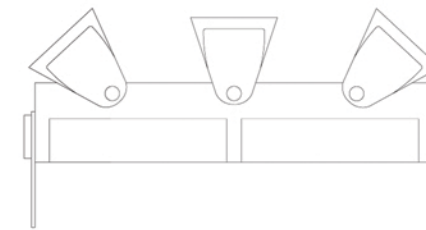
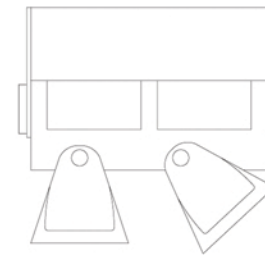

Since the double envelope structure would be beneficial for creating multiple layers, I wanted to look at the connections and structure of the screen I was going to create. As seen before I have a truss system with pinned connections. Since I had this language in the cantilever I decided that the screen in front of my building needed to speak in the same manner.

When you look at the wall structure I created to the right, you can see the different trusses that are repeated on each floor of the building. You can also see that the trusses attach to tube steel with the pinned connections. Plates of steel also tie tension cables that run the length of the wall structure. Like the truss system in the cantilever, there is the spider-joint system here in the green screen. When I looked at the structure, I asked myself, does the structure need to speak the same language as the cantilever, and does the structure dominate the screen? These questions would become important in the development of the structure.

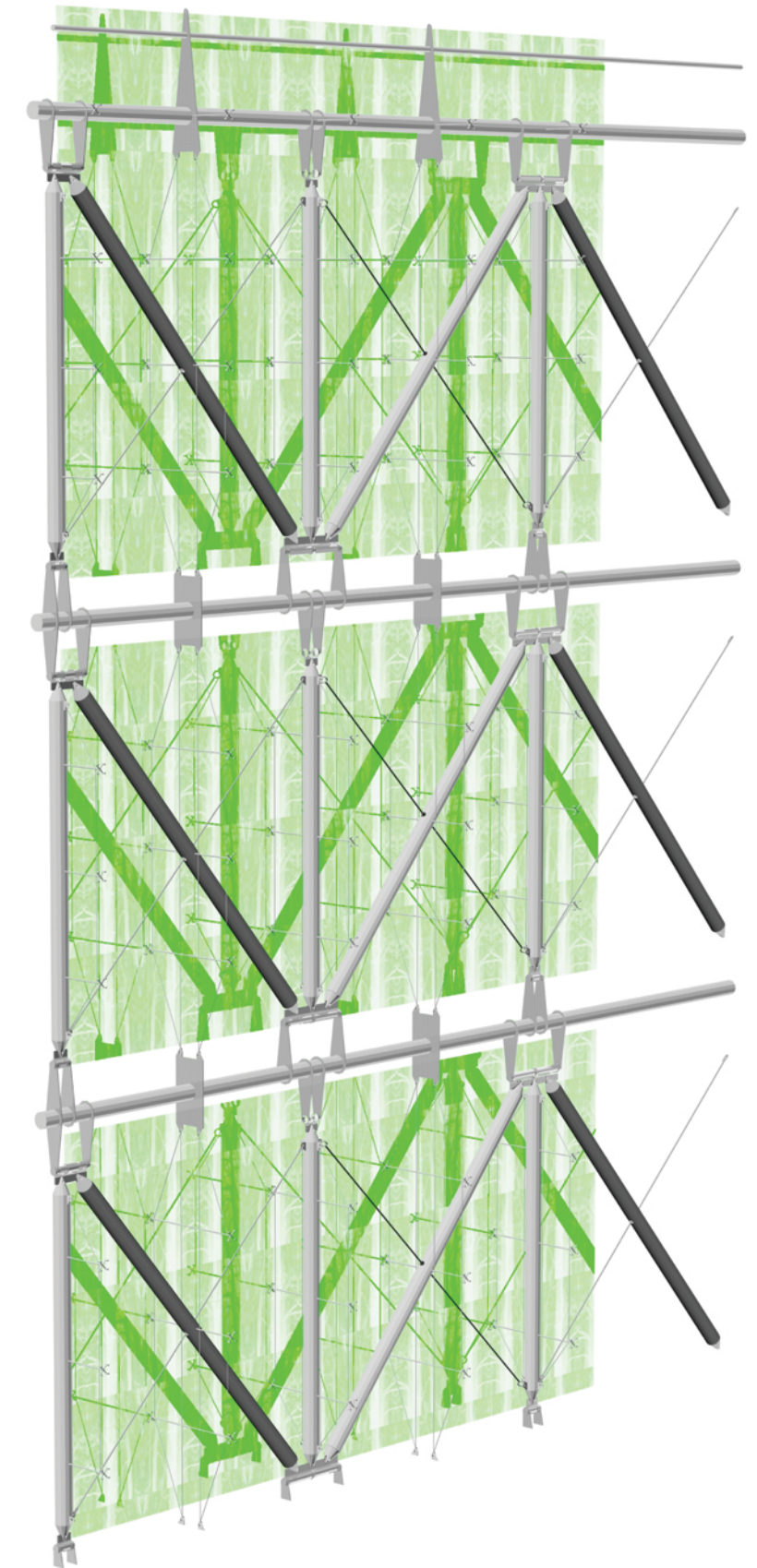

GREEN SCREEN

After analyzing the structure of the first screen iteration I decided that the structure was too much, and very complicated. The structure was dominating the verticals, and I wanted to create less diagonals and horizontals because of the verticality of trees. As you can see in the images, there is vertical tube steel that spans the height of the building, and is connected at the bottom with a bolted connection into plate steel, which is precasted into the concrete wall that holds the columns.

The columns are braced by stiffeners that are attached to the floor slab, and at the top is braced with more steel rod. On each column is a cable truss that is connected to spider-joints, which attach to the glass. Each connection is attached to the tube steel at the top of the structure, which ties the system together, and helps brace the system laterally in the opposite direction of the trussed stiffeners.

This system became less complicated, and eliminated a lot of the structure I didn't want. With the structure simplified the viewer can pay more attention to the screen I'm creating, rather than the structure I needed to support the screen, which was more important to my design.

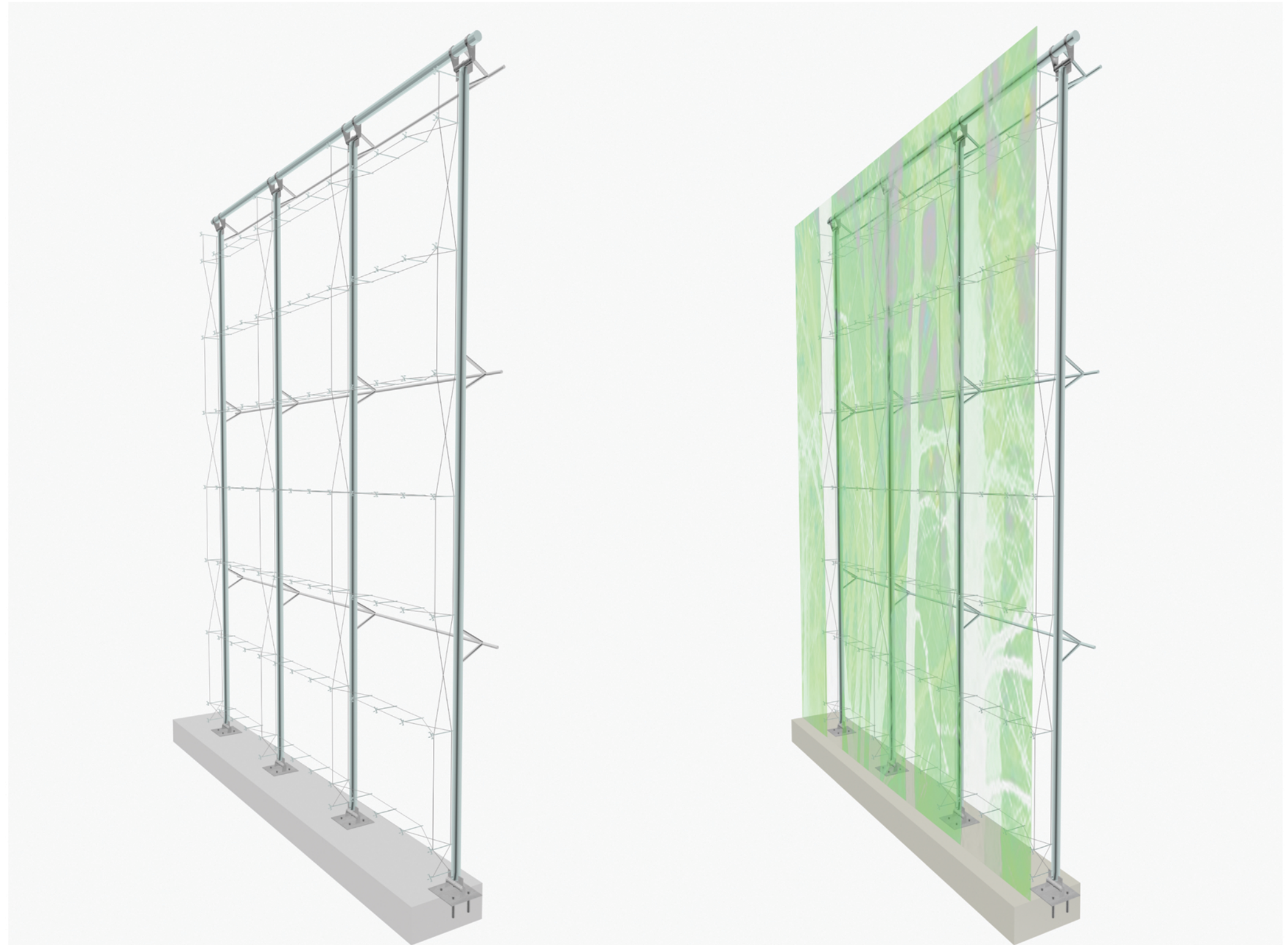

SCREEN STRUCTURE



COLUMN CONNECTIONS

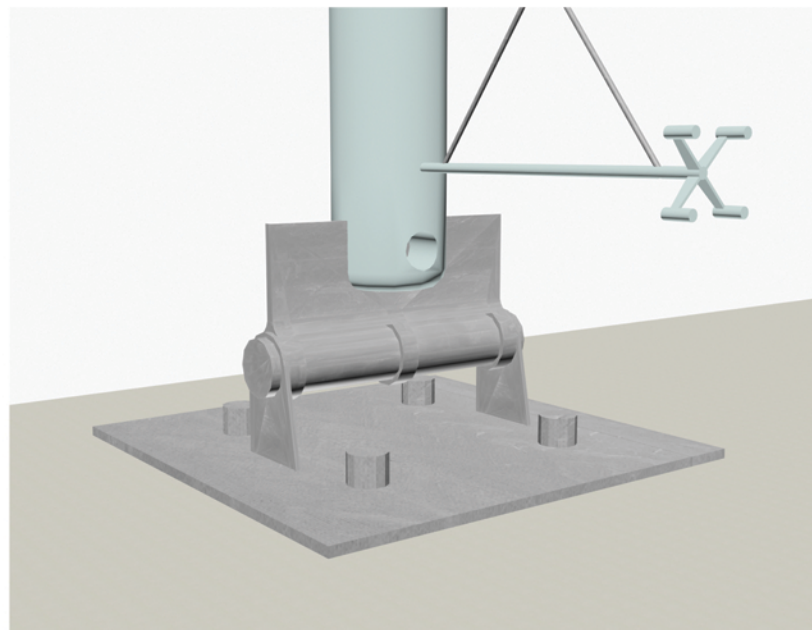

GREEN SCREEN SECTION

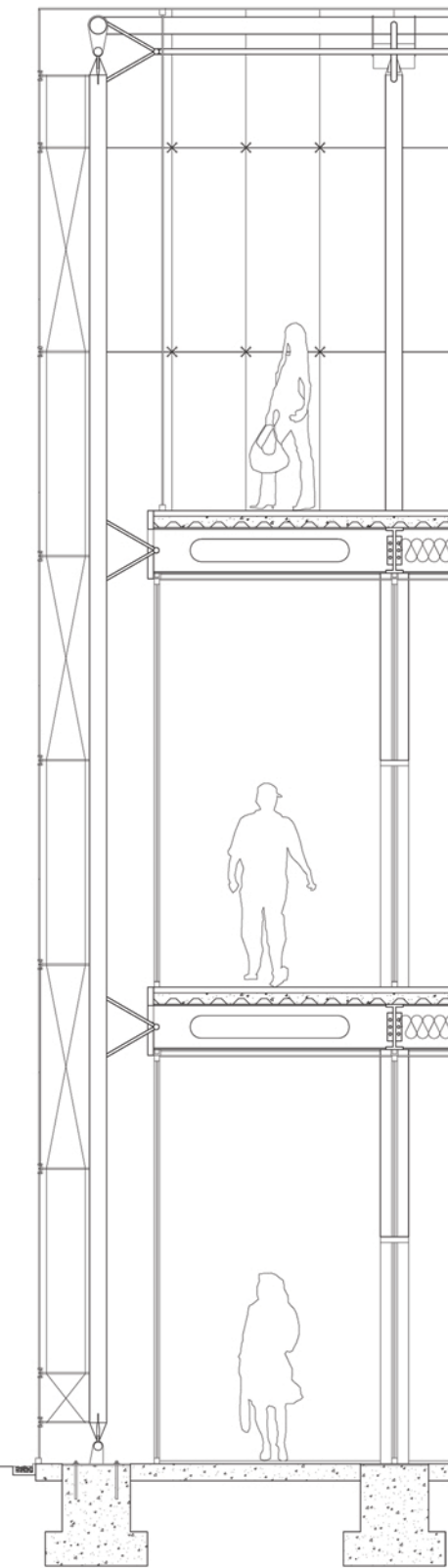

Detail of interior glass, which is not attached to the screen structure because of wind load.

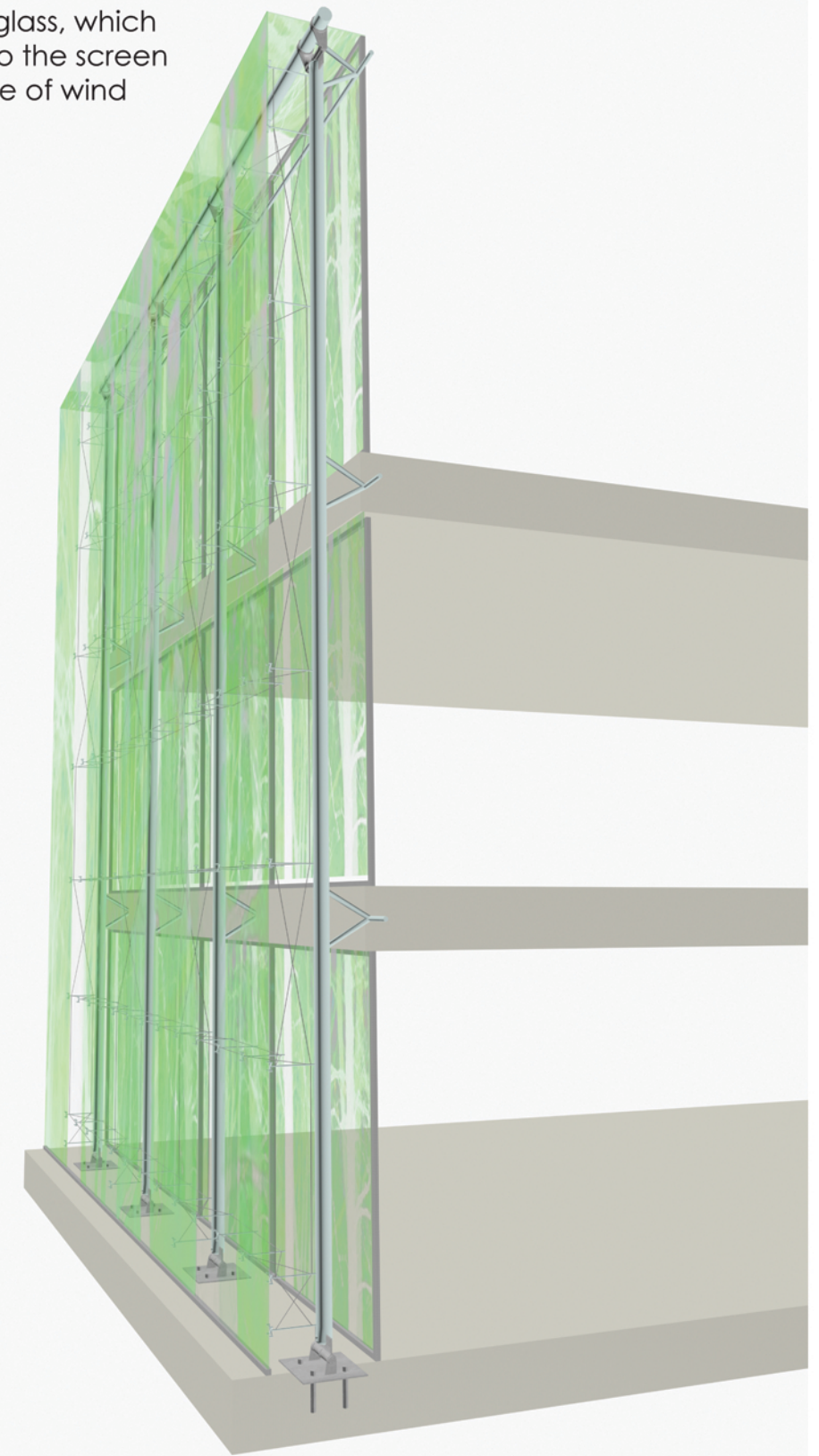

GREEN SCREEN

SILK SCREEN GLASS

The "Green Screen" was an idea that I wanted to pursue throughout the entire project. It is the basis of my thesis to create an architectural screen. Since I had figured out the structure of the envelope, I wanted now to create this image on glass in order to follow through with my design intent. So the way that this could become achievable through construction was silk screening onto glass.

Silk screen decorative glass is custom made by transferring a silk-screen image to the glass and then processing it through a horizontal tempering furnace. Each individual panel or lite is screen-printed with the desired pattern (right) and ceramic enamel frit color. The ceramic frit, or enamel coating with color and metal oxide protectant, can be silk-screened onto the glass substrate in one of three standard patterns—dots, lines, holes—or in a full-coverage application. In addition, custom patterns can be easily duplicated on the glass. Depending on the pattern and the color, the glass panel can be made transparent, translucent or opaque.

Silk-Screened (Ceramic Enamel Frit) Colors: Ceramic enamel frit is offered in the following standard color options: White, Black, and Etch. A wide range of more traditional colors, as well as custom colors may be done as well. While clear glass is a common substrate for silk-screened glass, there is a wide range of glass types that ceramic enamel frit can be applied.



Standard Silk-screened Patterns



Custom Silk-screened Patterns



Thickness: 1/8" through 1/2".

Size: Maximum size is generally 72" x 120".

Minimum size is 12" x 12".

The maximum glass size will vary with glass thickness and equipment capabilities

- Silk-Screened Standard Line Pattern: 1/8" lines on 1/4" centers covering 50% of the glass surface.
- Silk-Screened Standard Dot Pattern: 1/8" dots staggered on 1/4" centers covering 40% of the glass surface.
- Silk-Screened Standard Hole Pattern: 1/8" holes staggered on 1/4" centers covering 60% of the glass surface.

TRUSS CONNECTIONS

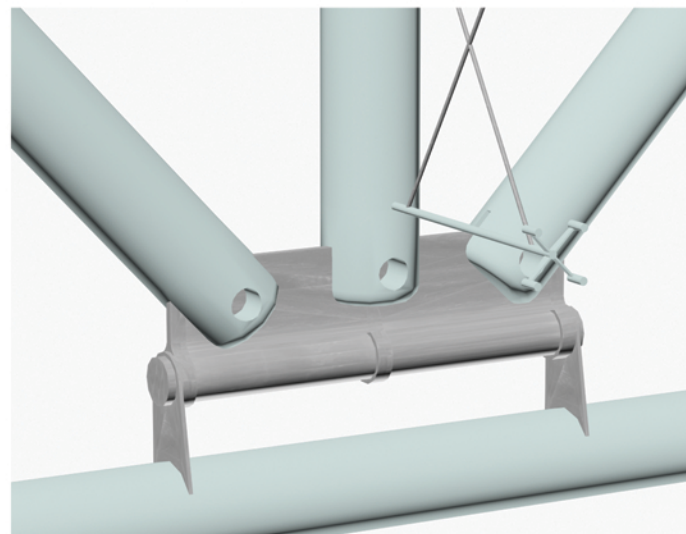
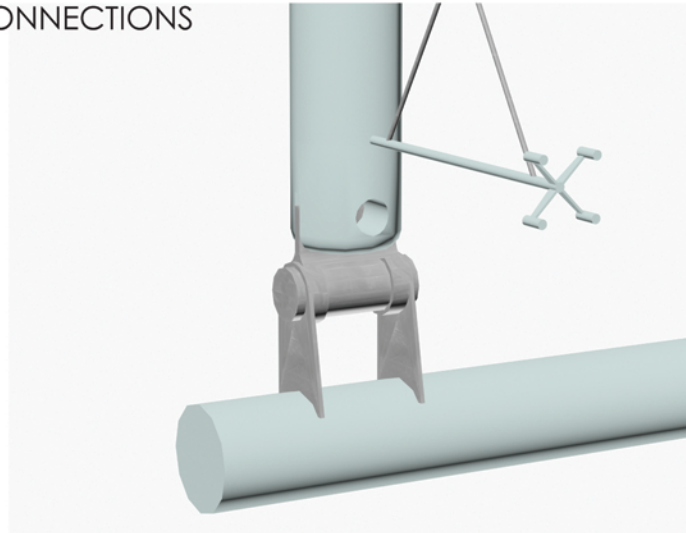

TRUSS STRUCTURE

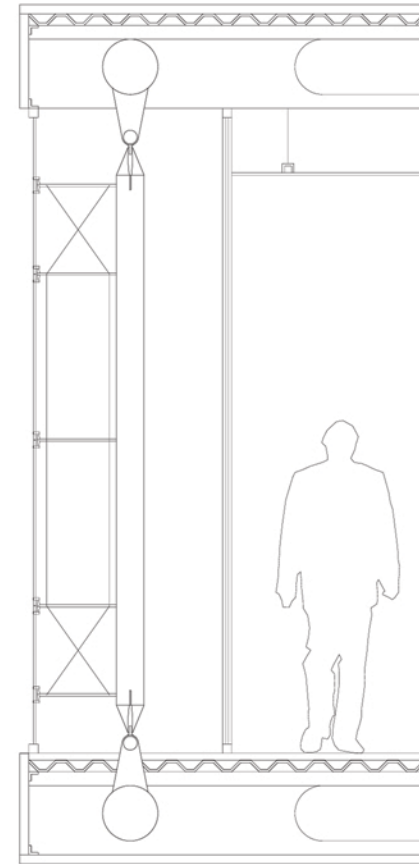
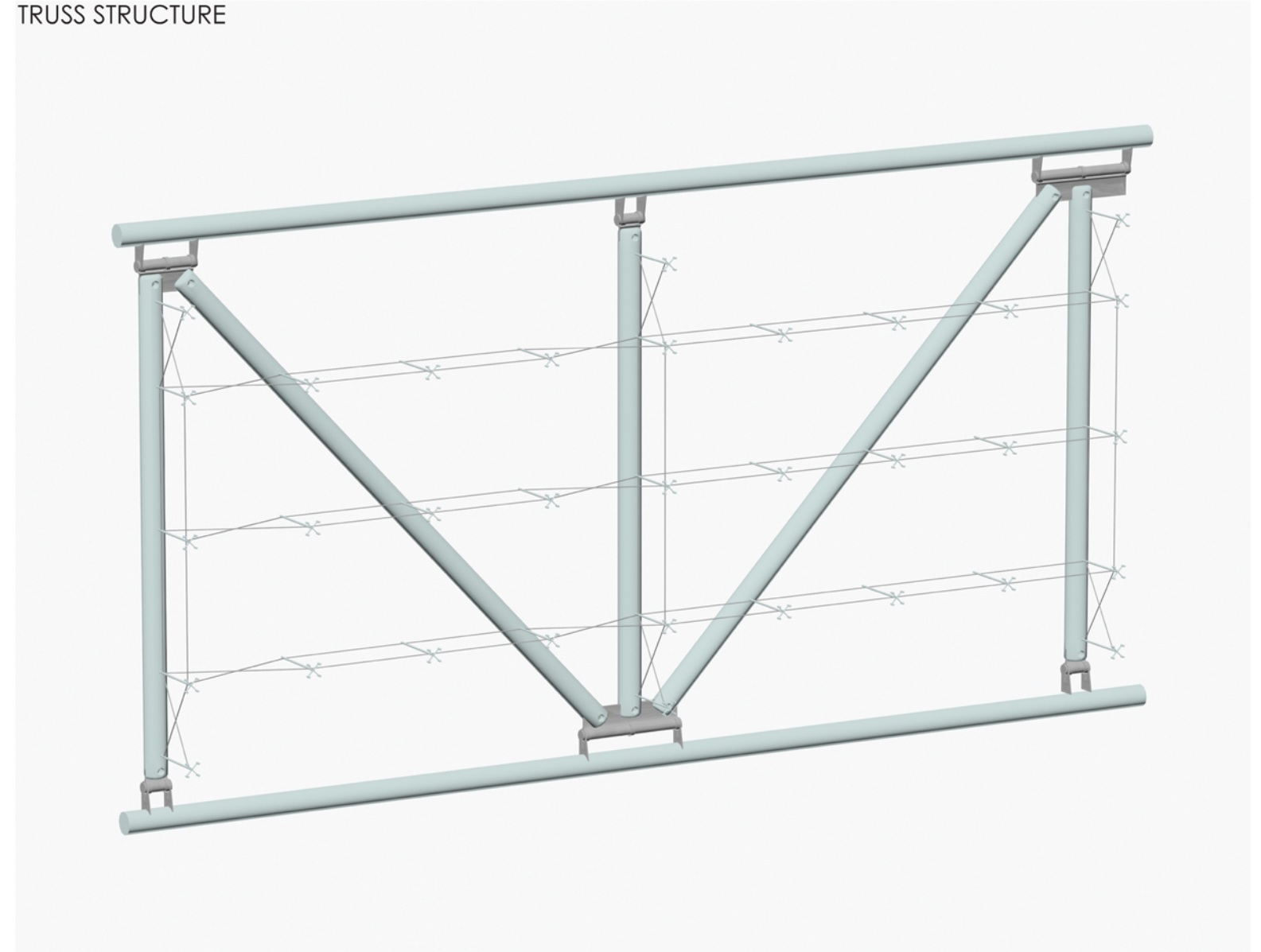

BUILDING TRUSS SECTION

Now that I've explored the structure of the green screen, and simplified the structure to accommodate my design ideas, I thought that I would use the same rationale in the development of the truss structure in my cantilever. The pinned connections would be the same, but there would be a welded connection to the tube steel. The truss would also contain the spider-joint system on the outside of the truss, which would connect to the outer glass structure, but the interior glass would be independent because the wind load doesn't have to effect the interior glass of the building. These systems become very intricate, and slender so that the entire cantilever can float where structure almost disappears.

STRUCTURAL PLAN

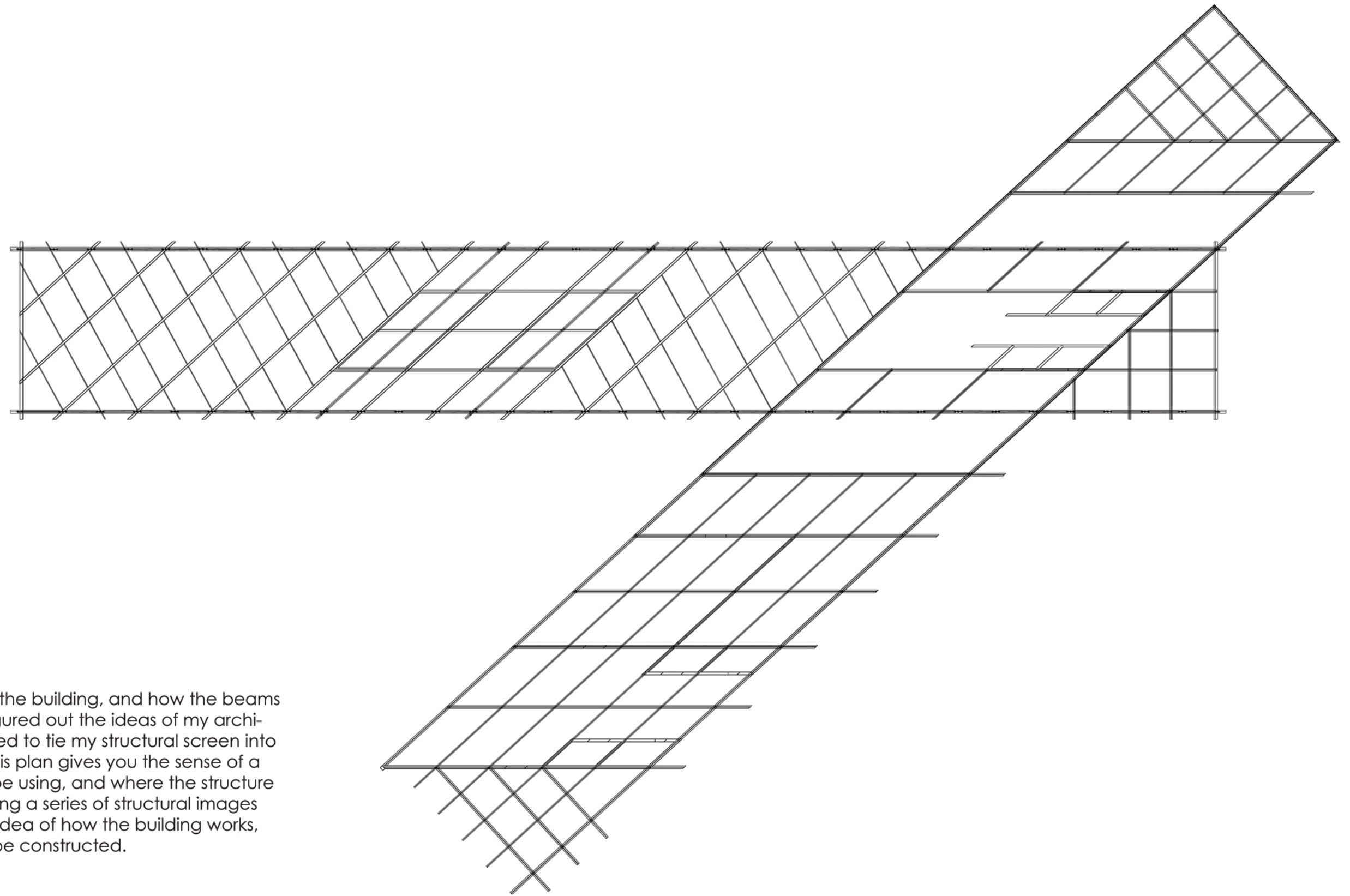

Here is a structural plan of the building, and how the beams are laid out. Since I had figured out the ideas of my architectural wrap, I now needed to tie my structural screen into the building as a whole. This plan gives you the sense of a steel construction that I'll be using, and where the structure is anchored. I will be showing a series of structural images that will give you a better idea of how the building works, and how the building will be constructed.

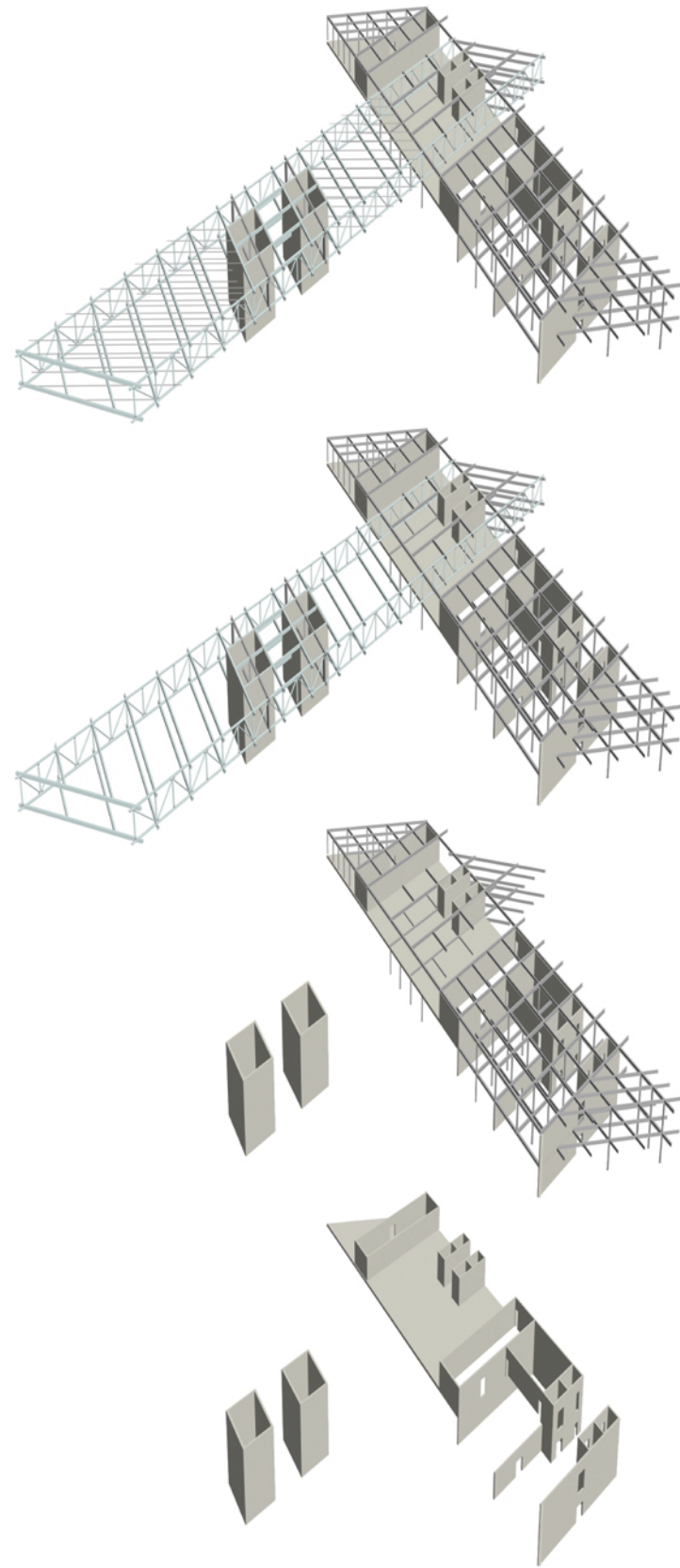

EXPLODED CONSTRUCTION

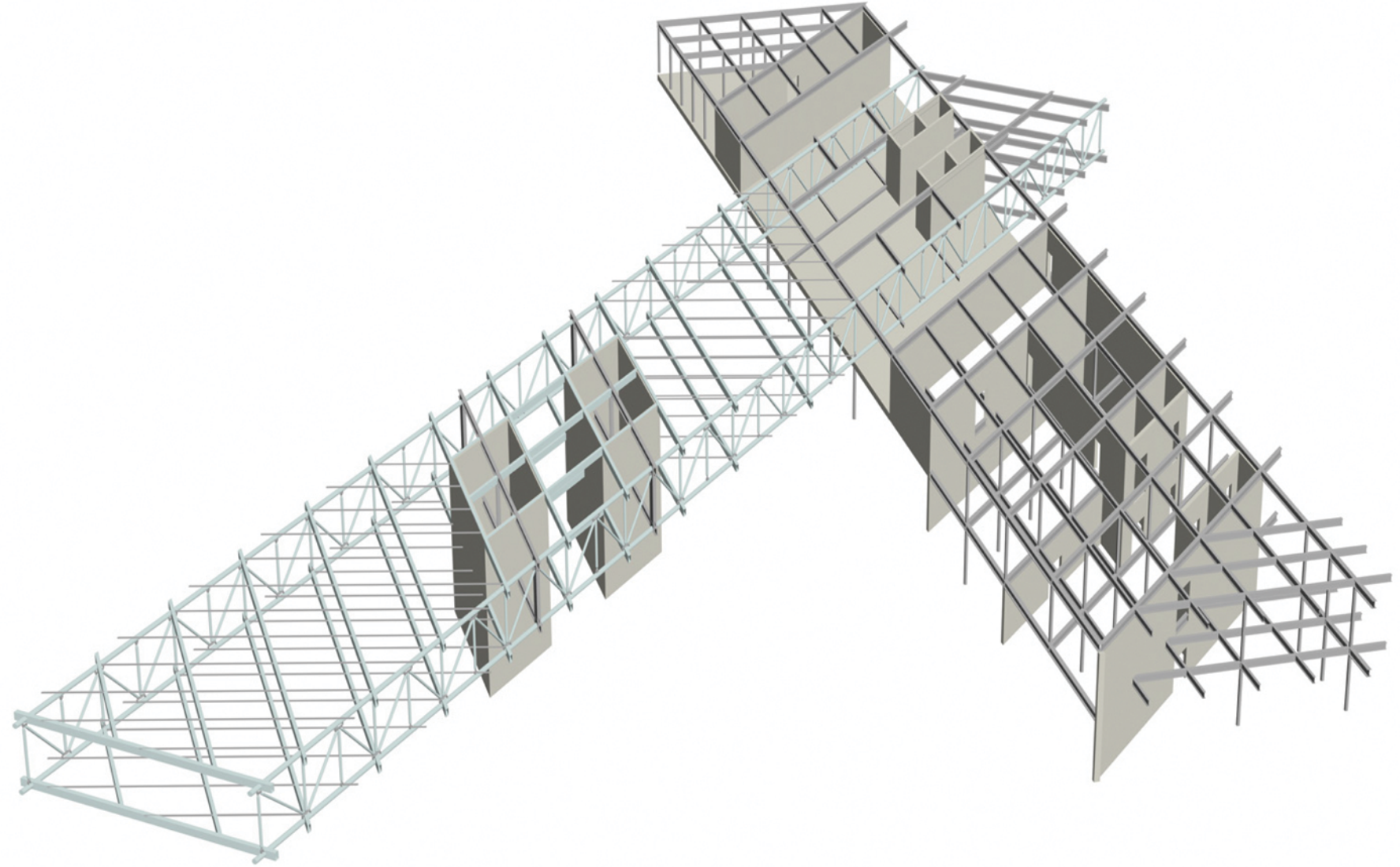

STRUCTURAL DIAGRAM

The construction of the building consists of steel wide flange beams on the ground floor, and poured-in-place concrete walls that help to support the building. The cantilever consists of steel construction, but of steel tubes. The trusses are round steel tube, and the girders have a rectangular cross section. The round steel truss is welded to the rectangular steel girders, which are held in place by lateral supports that lay in between each girder. The cantilever is being held at the center of the structure by two vierendeel trusses, which sit on two concrete cores that carry the load back to clubhouse building. The cantilever is then held by another service core made of concrete, which holds the back end of the cantilever. In each building the principal idea was to hold the steel structure with concrete service cores or walls.

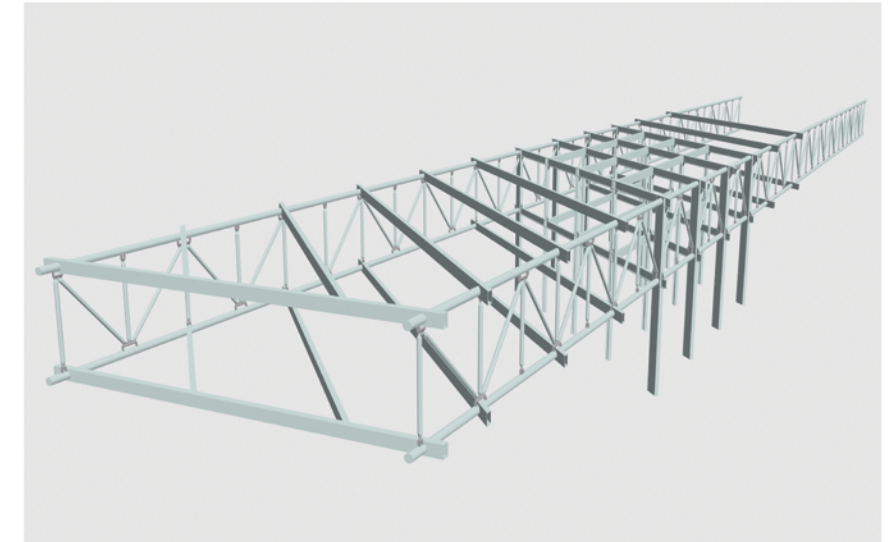
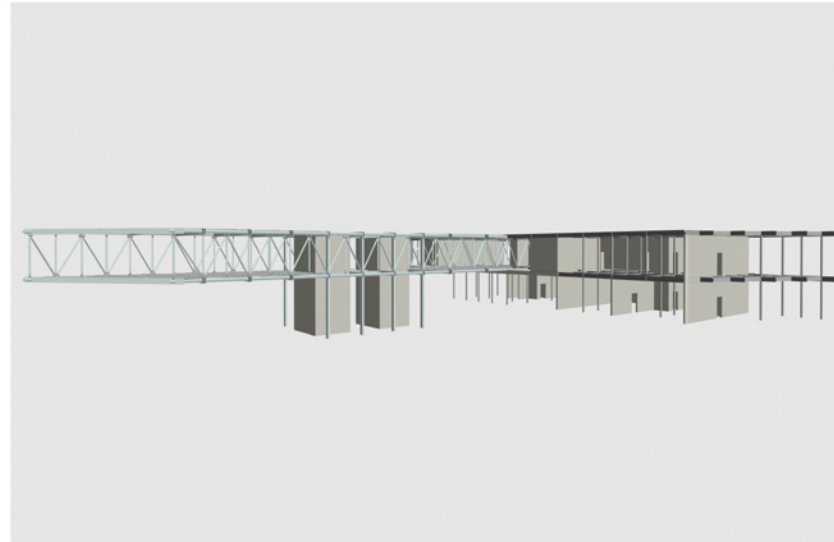
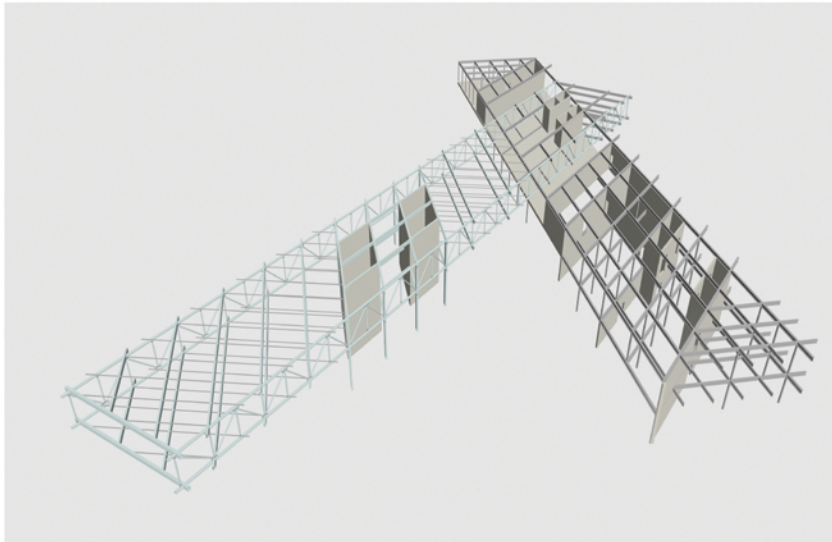

STRUCTURAL DIAGRAMS

When thinking about the structure of the cantilever I knew that the anchor would be the concrete cores that I created for service. I needed to figure out how I was going to control the bending moments at this point. I initially had the truss attached to the cores simply with steel beams. I then realized that this wouldn't be enough support for the great cantilever I was creating. The alternative was to create columns at these points to support this truss. When looking at these diagrams I decided that the columns defeated the idea of my design, because I wanted to create a floating effect, and eliminate structure not add it. There was one more alternative, and that was to create trusses that would support the bending moment at these points. The question was, how was the truss going to interfere with the circulation of the building?

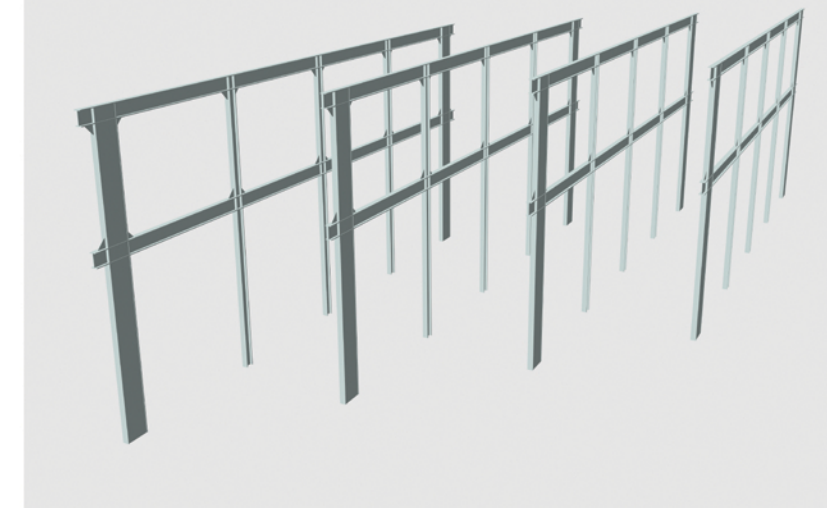
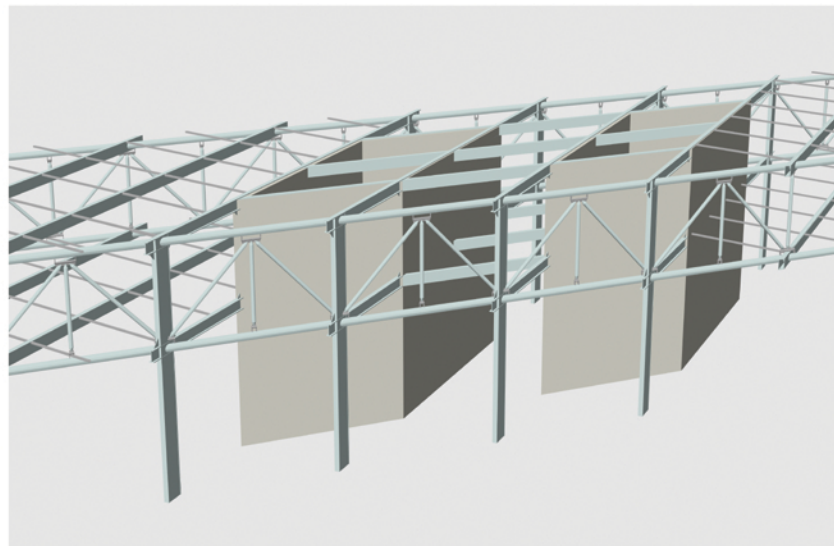
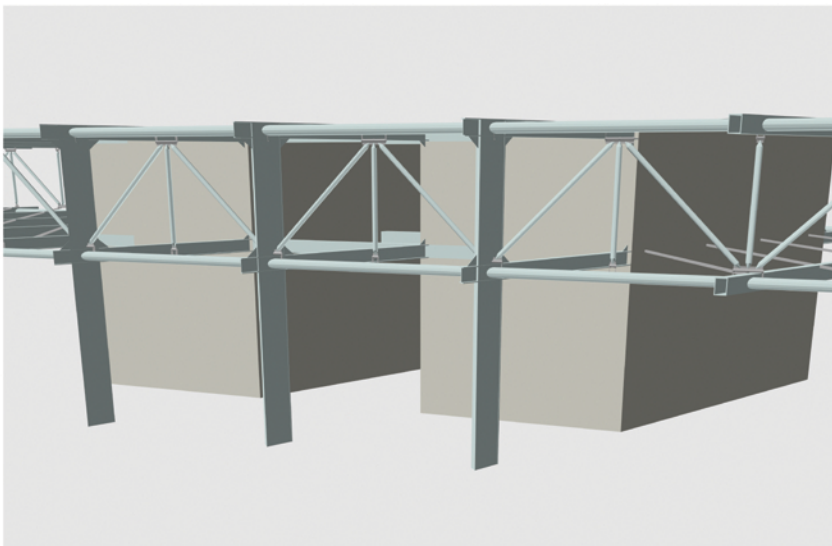
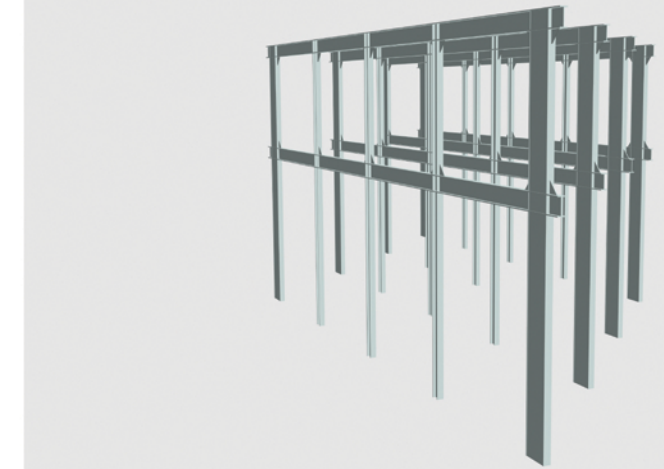

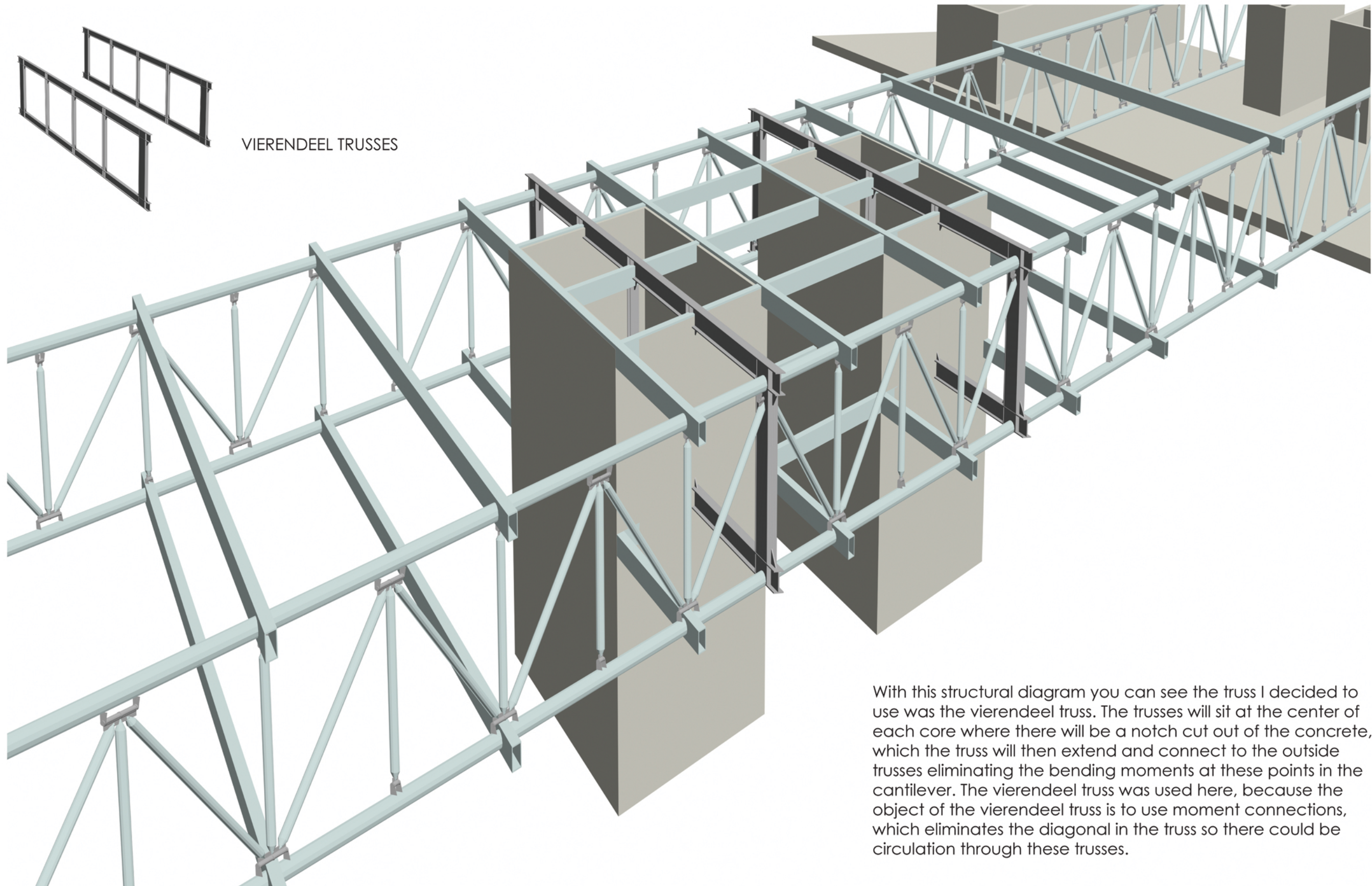

VIERENDEEL TRUSSES

With this structural diagram you can see the truss I decided to use was the vierendeel truss. The trusses will sit at the center of each core where there will be a notch cut out of the concrete, which the truss will then extend and connect to the outside trusses eliminating the bending moments at these points in the cantilever. The vierendeel truss was used here, because the object of the vierendeel truss is to use moment connections, which eliminates the diagonal in the truss so there could be circulation through these trusses.

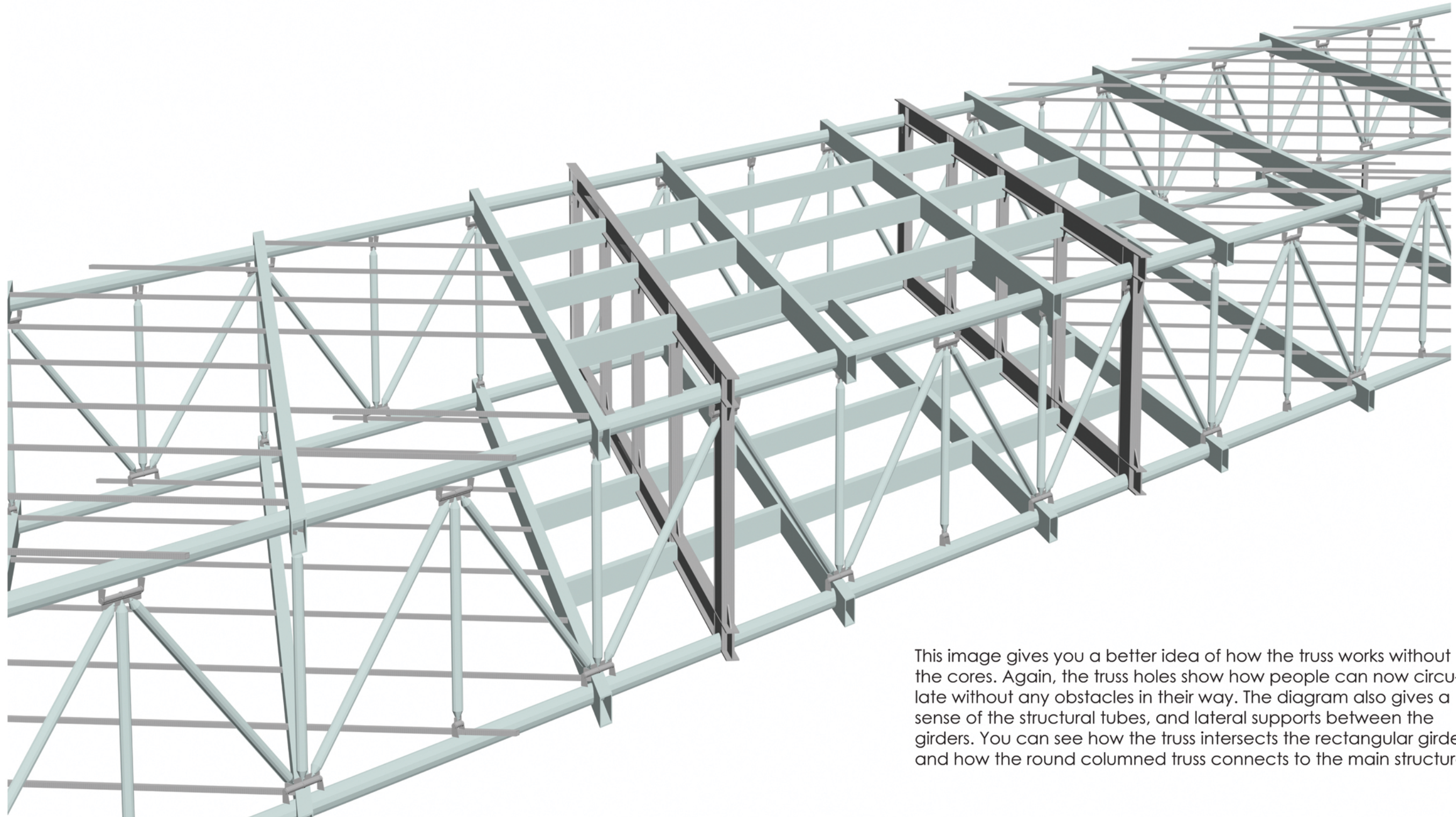

This image gives you a better idea of how the truss works without the cores. Again, the truss holes show how people can now circulate without any obstacles in their way. The diagram also gives a sense of the structural tubes, and lateral supports between the girders. You can see how the truss intersects the rectangular girders, and how the round columned truss connects to the main structure.

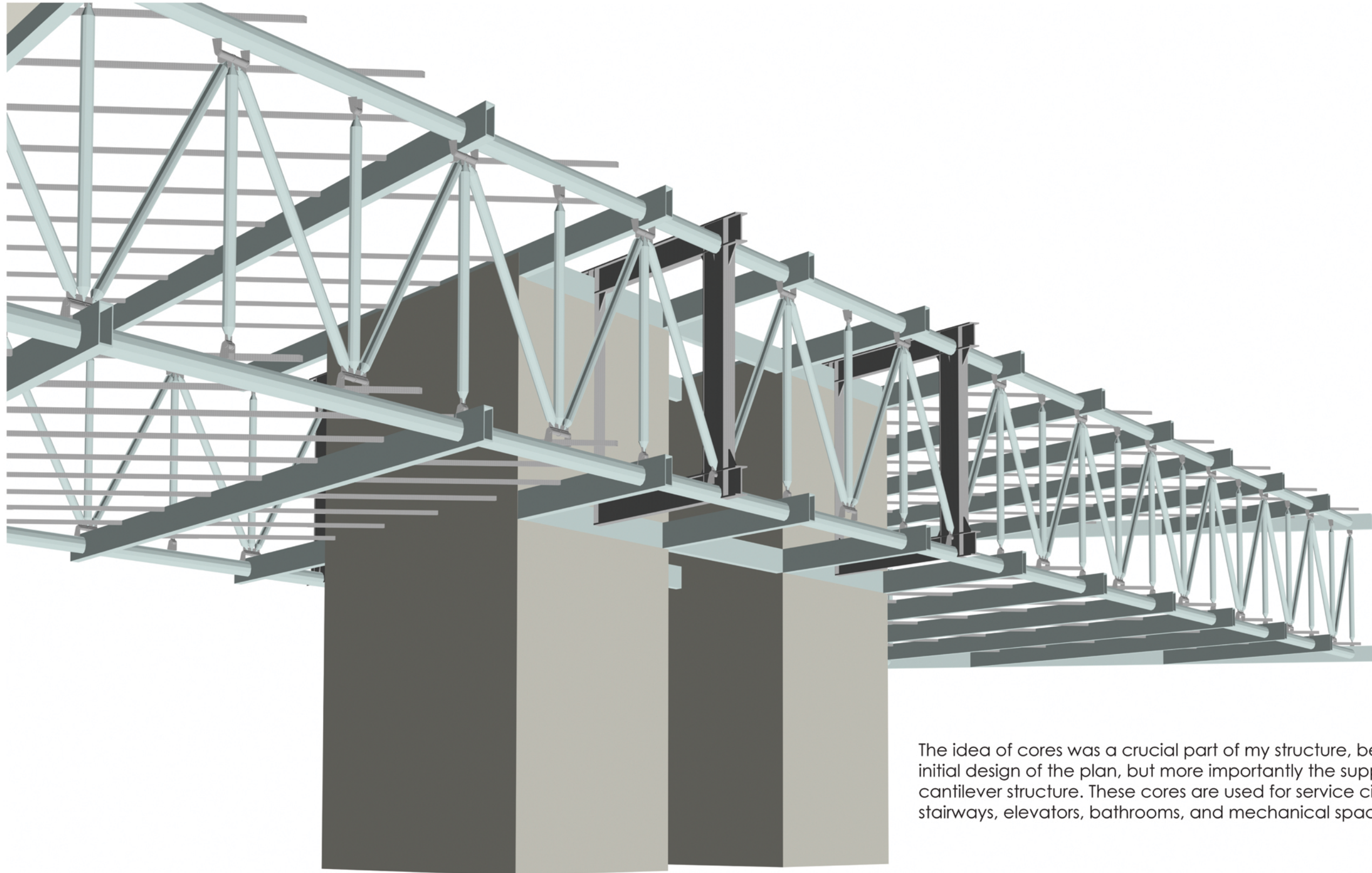

The idea of cores was a crucial part of my structure, because of the initial design of the plan, but more importantly the supports to the cantilever structure. These cores are used for service circulation as stairways, elevators, bathrooms, and mechanical spaces.

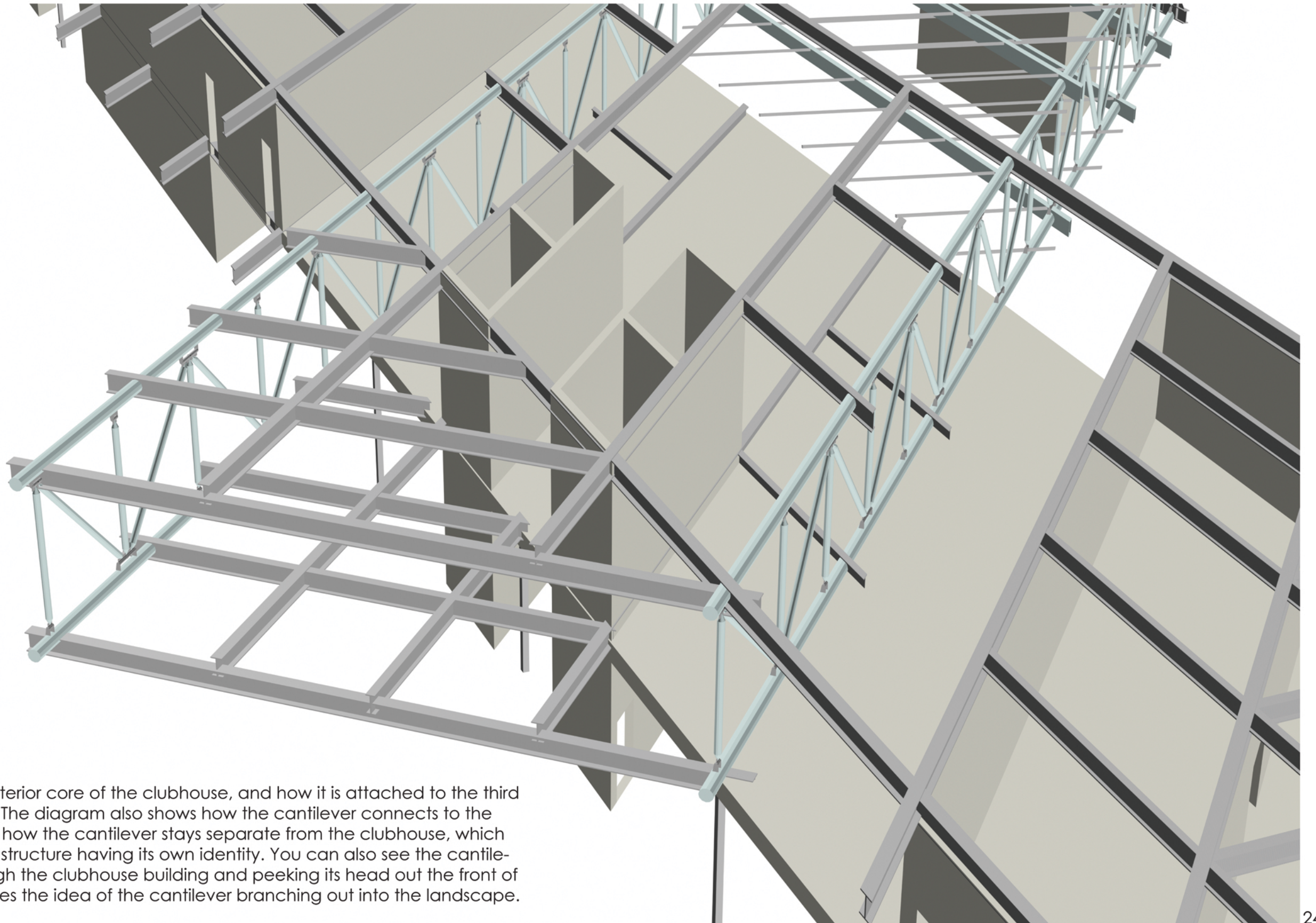

This diagram shows the interior core of the clubhouse, and how it is attached to the third floor cantilever structure. The diagram also shows how the cantilever connects to the clubhouse structure, and how the cantilever stays separate from the clubhouse, which defines the idea of each structure having its own identity. You can also see the cantilever structure going through the clubhouse building and peeking its head out the front of the building . This reinforces the idea of the cantilever branching out into the landscape.

FLOOR PLANS

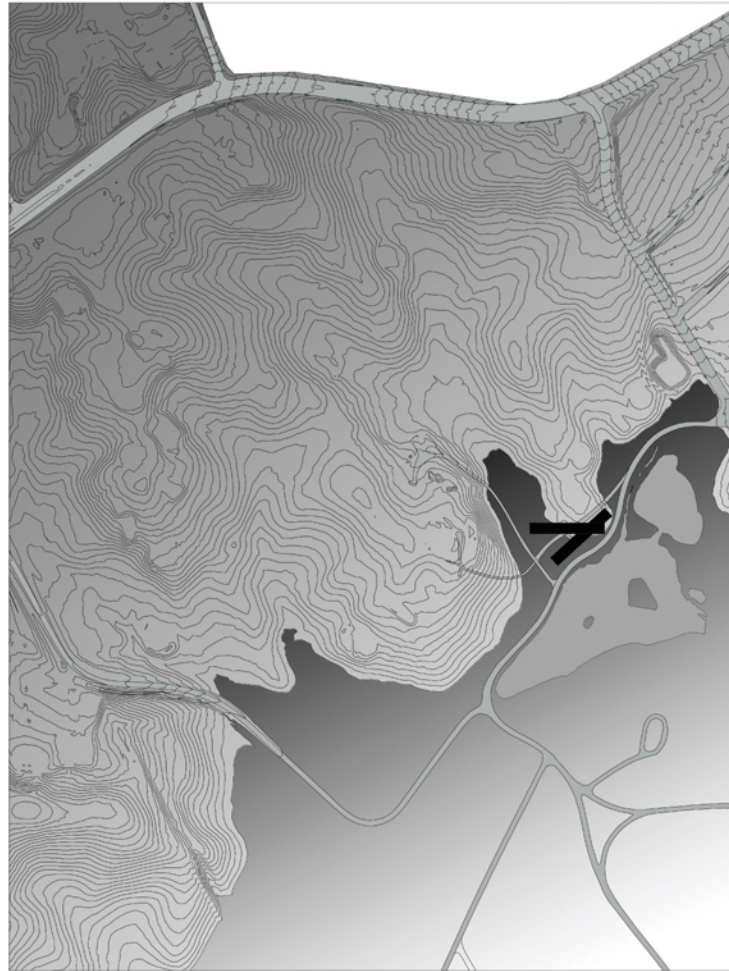

GROUND FLOOR PLAN

The ground floor consists of the pro-shop, cart storage, and lounge areas. Because of the elevation change there is ground floor that creates a convenient pro-shop, where visitors from the university can pay to play, and not have to go into the main building. The pro-shop is located in front of the practice putting green for easy access. After a hard day at the course the players can sit down at a lounge down-stairs without walking upstairs.

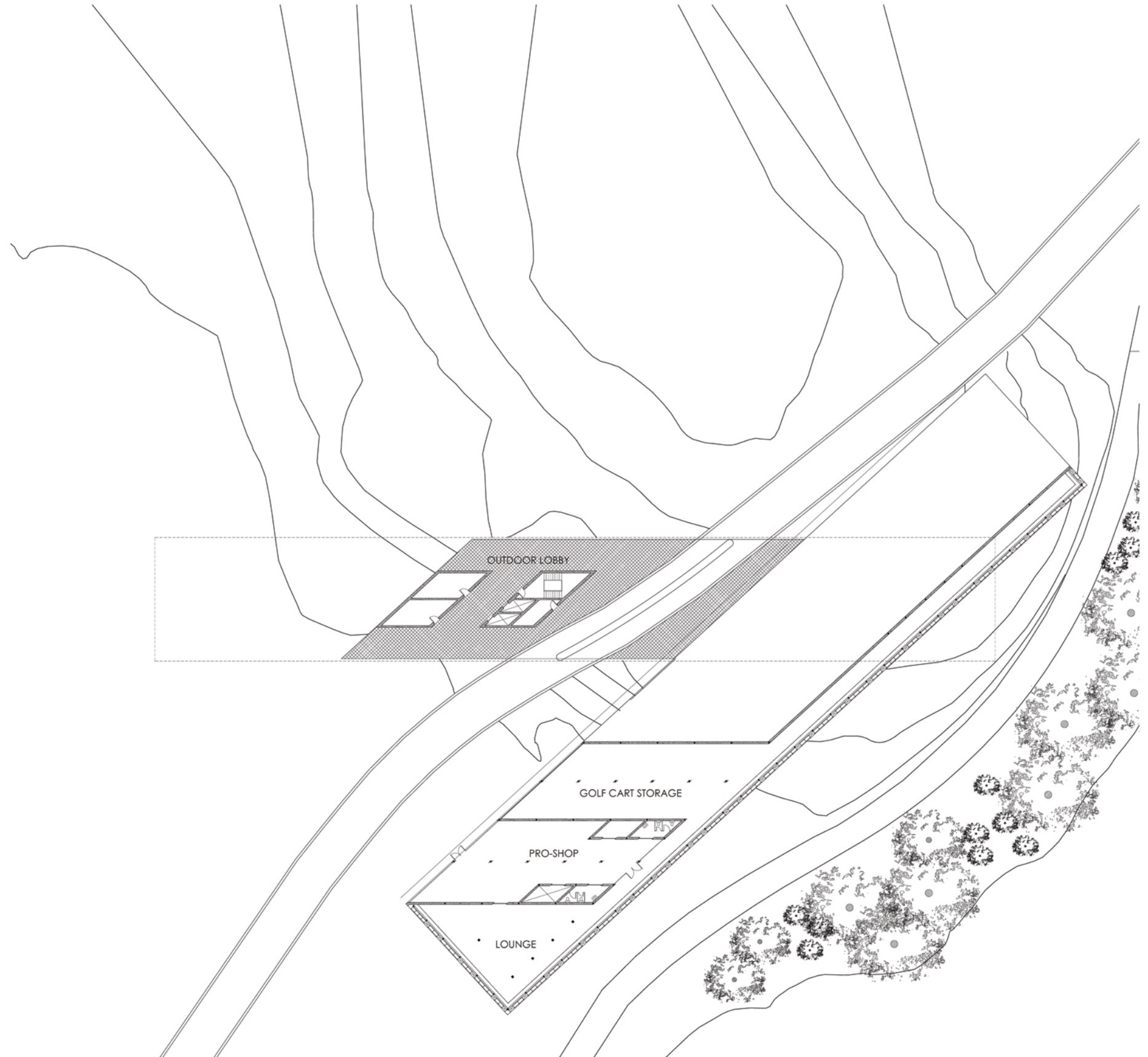

FIRST FLOOR PLAN

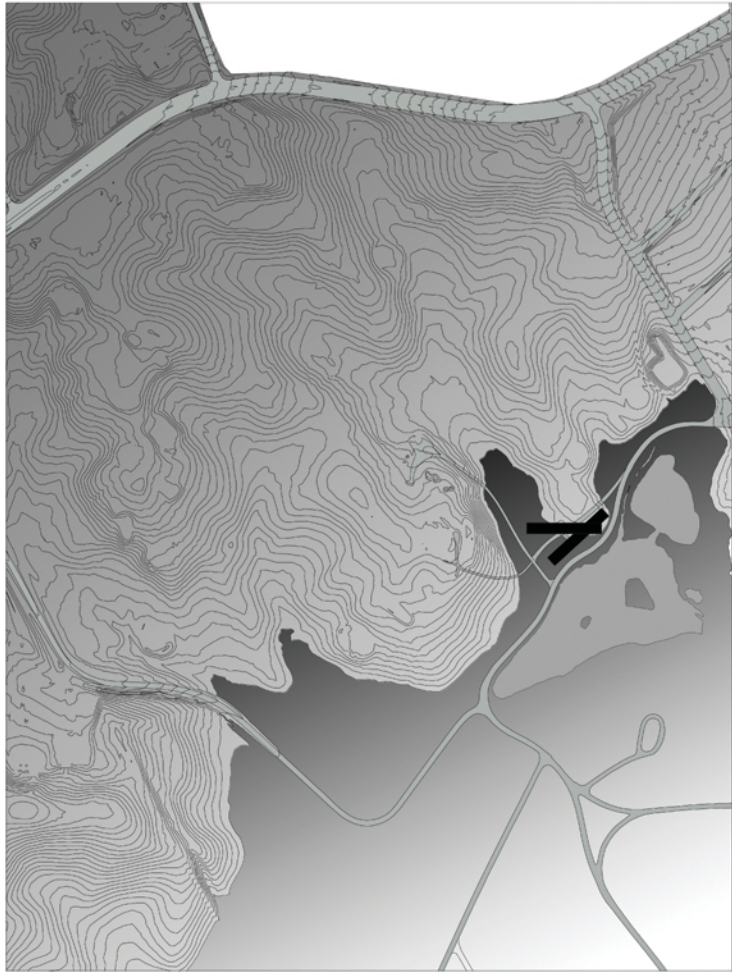

The first floor plan is the entrance to the clubhouse. The clubhouse consists of locker rooms for men and women. The multi-sex clubhouse allows visitors from the Holtzman Alumni Center Hotel to come and play while on vacation. There is a grand atrium space as you enter, and informal dining spaces that allow you to eat lunch during the day. There are also lounge or bar spaces for social gatherings in the day-time. All spaces are lit by the wrapped green screen.

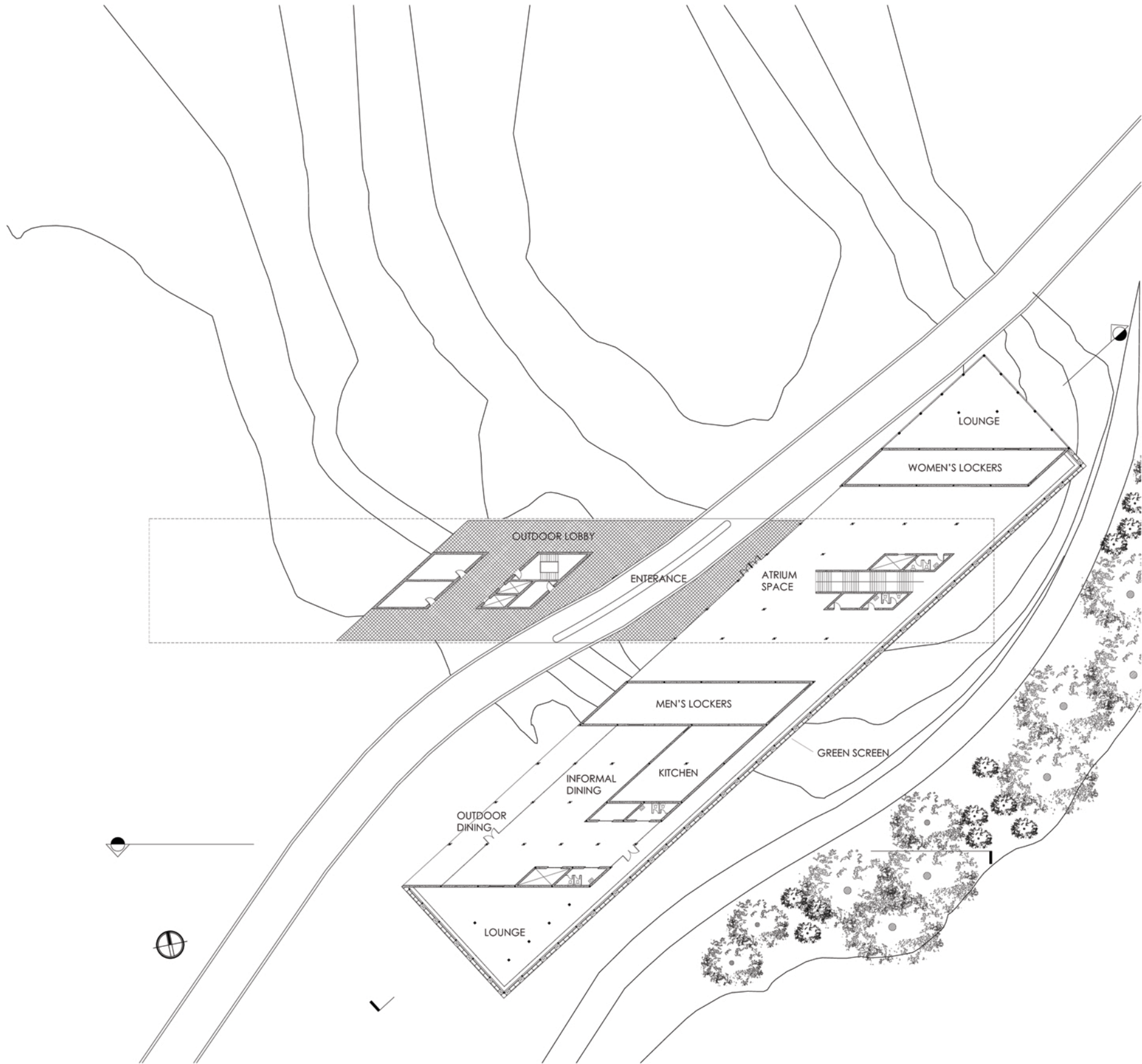

SECOND FLOOR PLAN

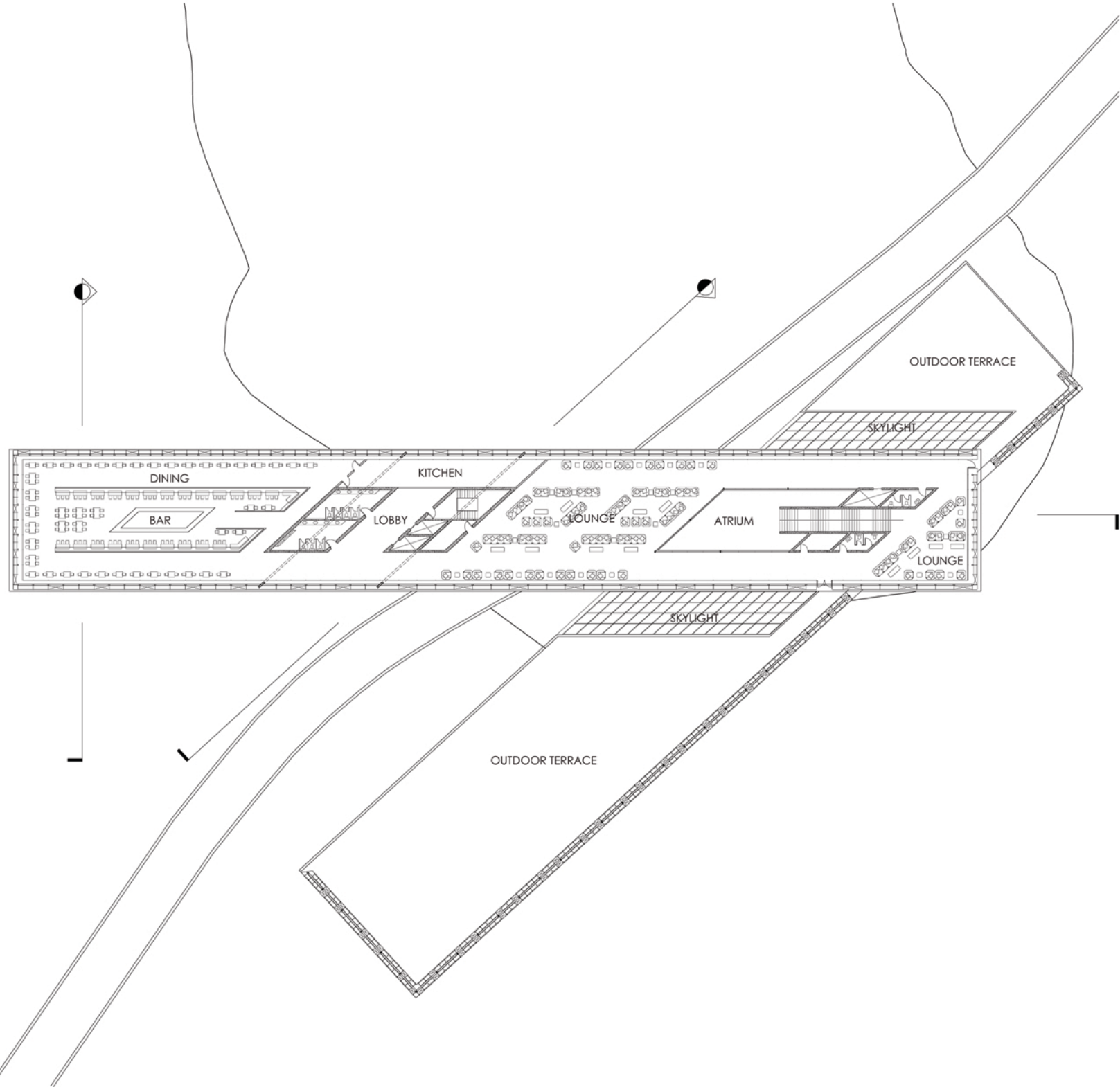
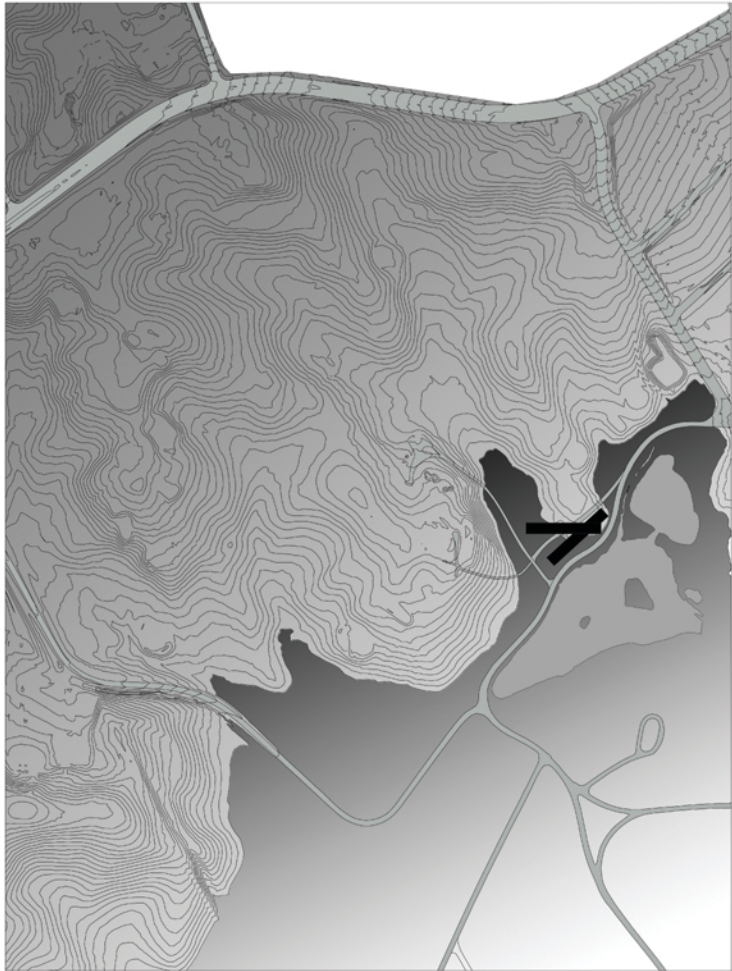

The second floor consists of the formal dining, atrium and pre-function lounge spaces before special events. The second floor allows golfers to wait for tee times, as well as view when they are playing. It also serves as a place to relax from the sun after play. At night the space becomes a formal restaurant, which serves members of the club as well as visitors of the Alumni Center Hotel. The second floor becomes monumental because of the branching cantilever into the landscape of the golf-course.

SECTIONS

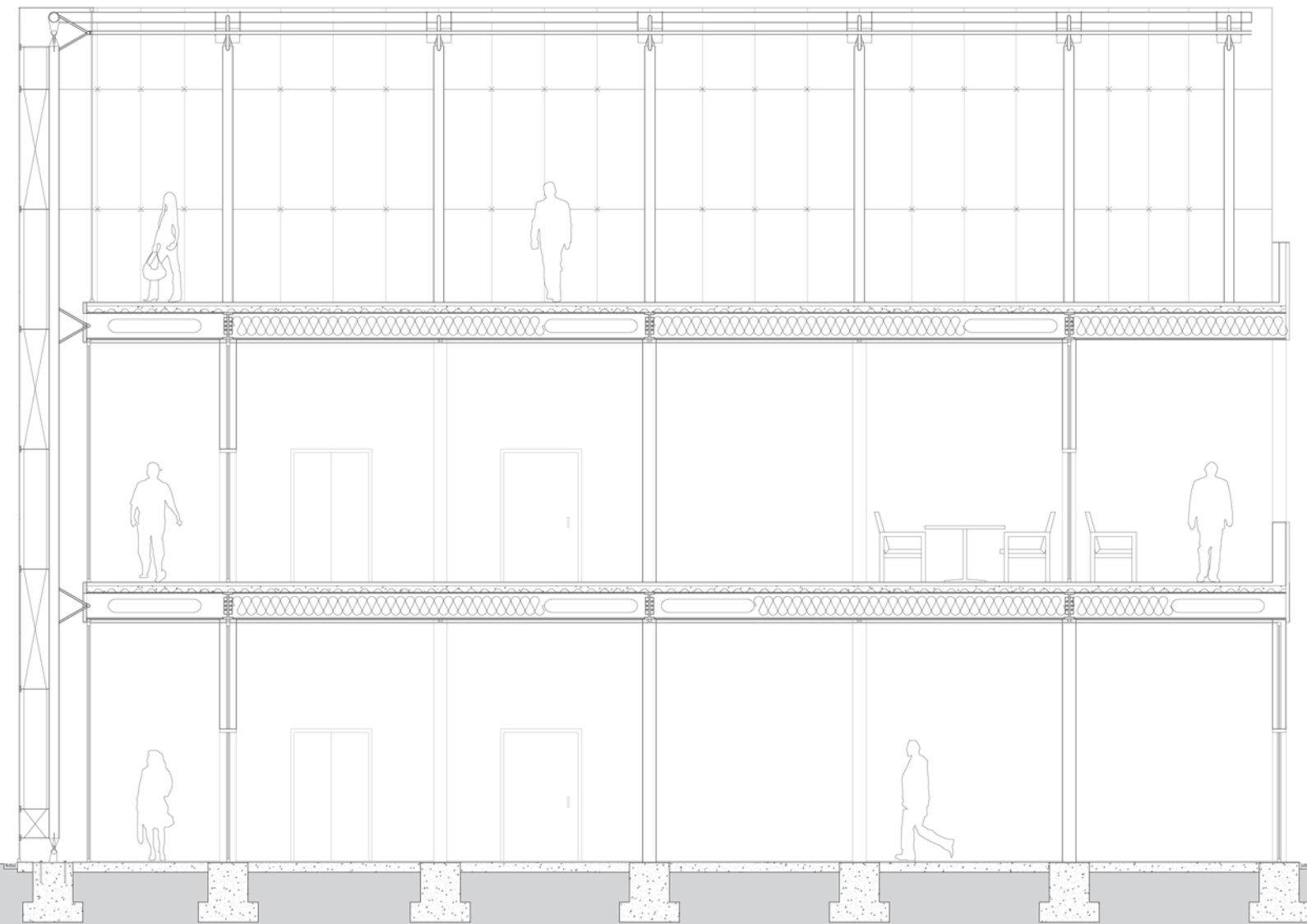

CURTAIN WALL SECTION

The Curtain wall or "Green Screen" section shows how the curtain wall is constructed and attached to the clubhouse. There is one long piece of tube steel that runs the length of the building, which is cable trussed and attached to the steel structure of the building. The cable truss works to support the forces of wind load as well as the glass "Green Screen." The curtain wall extends to the roof terrace, which acts as trees for a roof garden. The section also shows the circulation of the clubhouse is in the front of the building where the curtain wall can be experienced. Like the steel structure in the cantilever, there is space provided through the steel I-beams for HVAC.

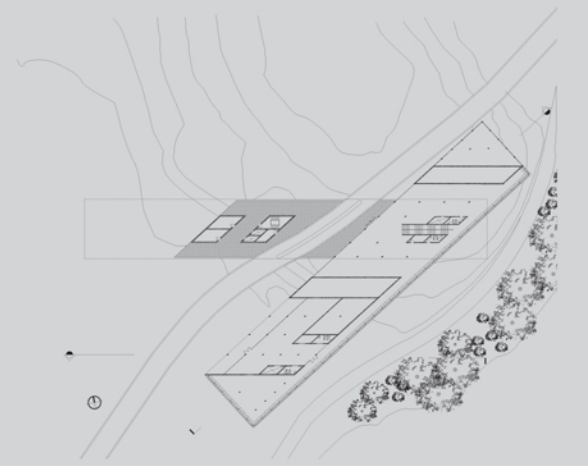

SOUTHWEST SECTION

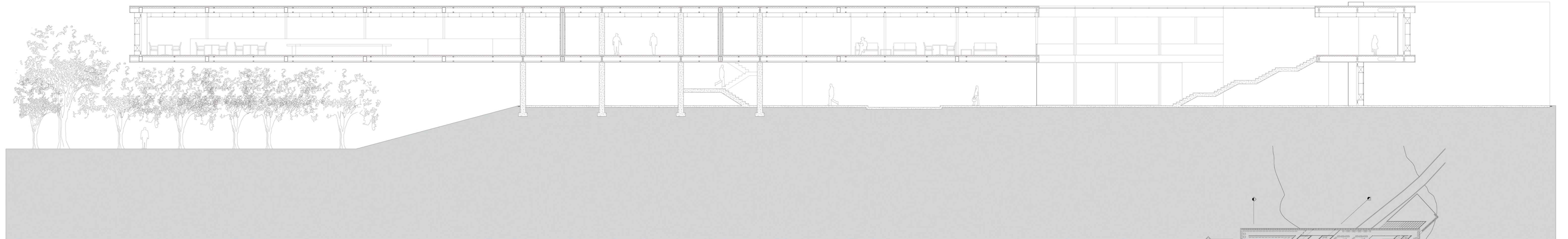

In the section you can see the steel construction that is being used, as well as the main columns that are supporting the structure. The restaurant is placed at the end of the cantilever where the structure branches out into the trees. This gives the golfer the sense of being on the golf course, while still being in the building.

SOUTH SECTION

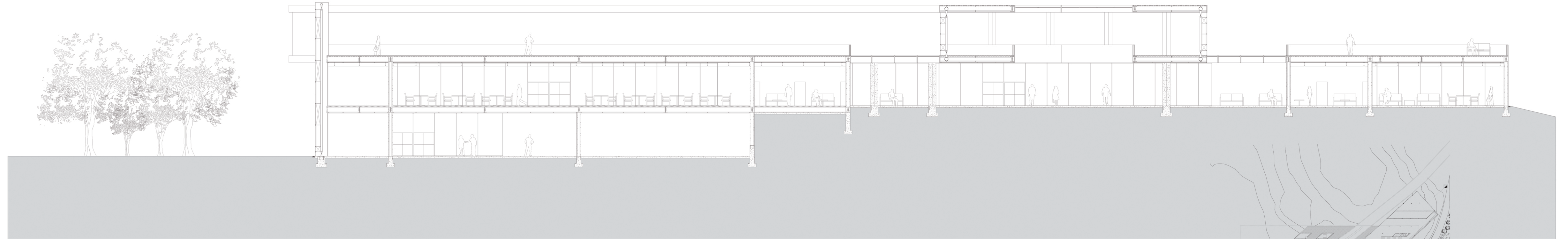

The south section shows the curtain wall as well as the many functions of the clubhouse. You can see the pro-shop on the ground floor, where the golfers can pay for their games, purchase accessories, and rent carts, as well as get advice from golf professionals. On the first floor entrance there are the men's and women's lockers, open atrium space, and informal dining/lounge areas. The most important part of these spaces is the generous room that is given for the golfers to relax after a long day on the course.

CANTILEVER SECTION

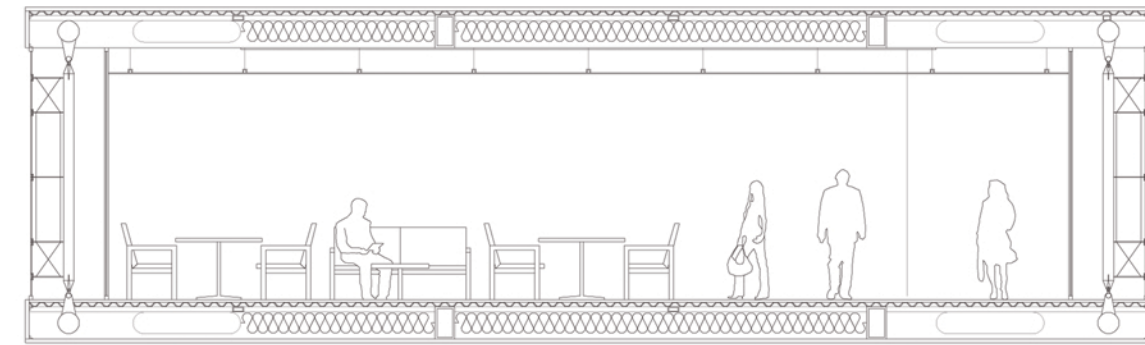

NORTH SECTION

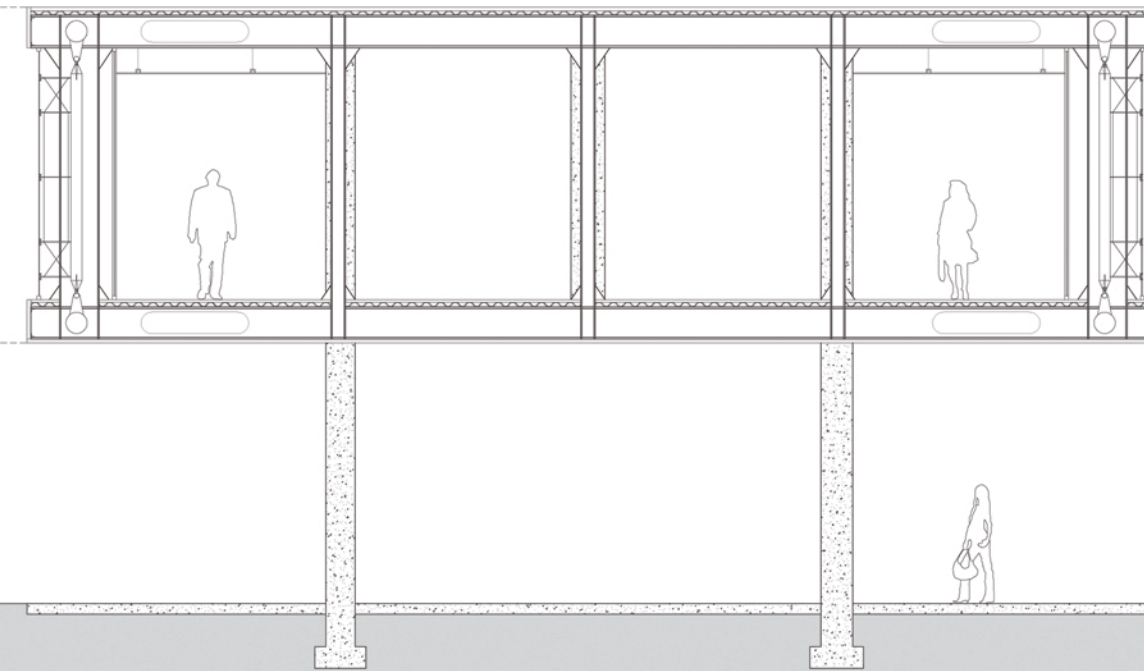

TRUSS SECTION

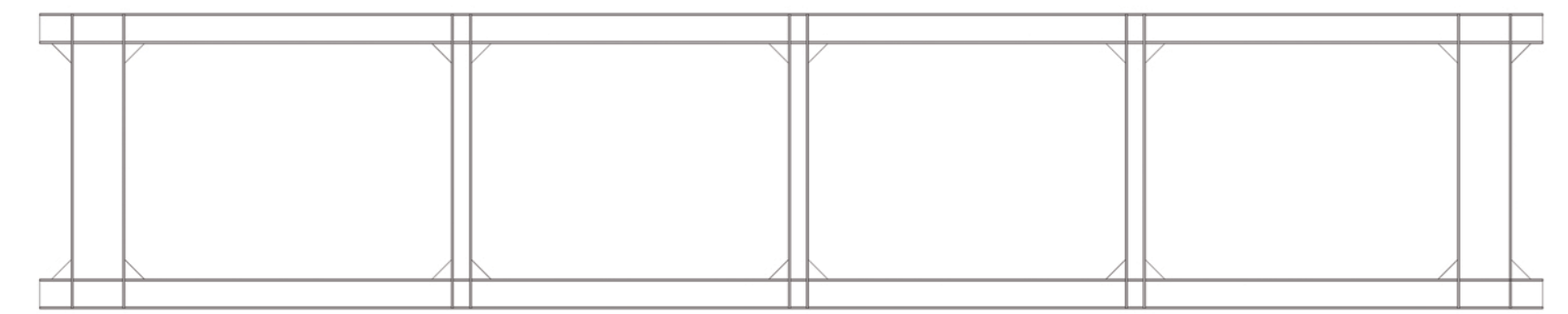

TRUSS ELEVATION

The north section specifically shows a section through the cantilever. The steel construction can be shown in the sections. The double envelope can be seen at the perimeter of the cantilever, which shows the cable truss system with spandrels that attach to the glass by spider joints. Again, the interior glass is independent of the cable truss to negate wind load on the interior of the building. The skin of the building is made of metal panels, and the glass panels are silk screened with the patented tree image. In the steel construction there are holes cut out for the HVAC system near the glass where the infiltration is the greatest, and the center near the formal dining. The mechanical systems will be contained in the cores, where the mechanical rooms are located.

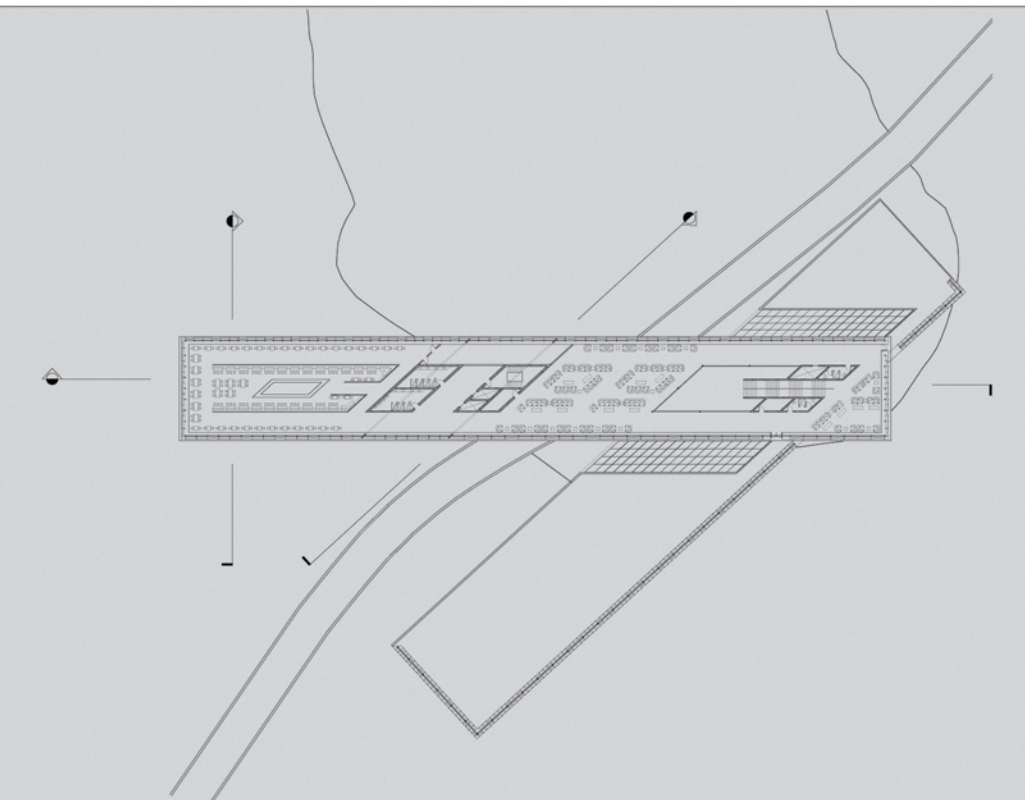

ELEVATIONS

SOUTHEAST ELEVATION



The southeast elevation is a good view of how the golf clubhouse interacts with the Holtzman Alumni Center and Hotel. One of the motivating factors to this project was creating spaces that could be used by the hotel to link these two buildings together. I've created a place to eat in the daytime for lunch, as well as golf activities for the visitors, and a great place for dinner and social gatherings at night. Thus, creating a social link between hotel and clubhouse.

SOUTH ELEVATION



The South elevation is the main access elevation from the road. This elevation begins to show the screen and the presence it gives to the site. The true picture of forest is now shown as you move further away, and begins to become part of the landscape. This elevation also shows how the second floor peeks its head out of the screen to give a hint of what's behind it. The space that comes through the screen is a lounge area where golfers can rest after playing on the course. People from the street can also see the presence of the cantilever branching out into the landscape, which overlooks the 1st hole tee-off.

SOUTHWEST ELEVATION

The southwest elevation is a good view of how people interact with the site. Parking is located in front of the building for easy access, but the main parking lot is to the west of the clubhouse. There is also a connection between players with the practice putting green in front of the pro-shop before golfers start playing. As the visitor passes they can watch players get instructions from golf professionals, which sparks excitement, interest, and curiosity in new players to the course.



NORTH ELEVATION

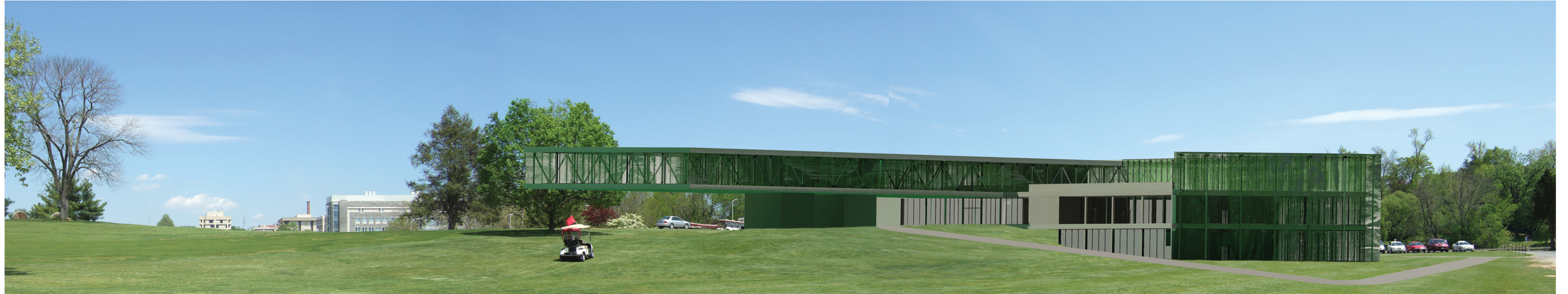

In this elevation you can understand the many parts that the clubhouse consists of, such as the entry up the hill, the pro-shop created by the elevation change, and the cantilever that is supported by the clubhouse. The cantilever really becomes a presence in the way that it reaches out into the landscape like a branch of a tree. Like a branch and how it supports many other branches, the cantilever is supporting many other people in the restaurant where the great view of the golf course, and the university can be experienced.

CONCLUSION

The development of an architectural wrap or "Green Screen," served as a contribution to the landscape. The building was giving back to nature, and through an architectural investigation of layers the clubhouse could benefit from the qualities of the screen.

The architectural screen I've created benefited the golf clubhouse in multiple aspects of the building. The screen served for better lighting qualities, shading to the sun, and double envelope system that created strong ventilation for the HVAC system, but most importantly created a nice visual aesthetic to my design.

The initial idea to my concept was a building that gave back to the landscape. I thought that this could be done by letting a part of the building be part of nature or the landscape. In my thesis this was done through an architectural screen with a series of layers and aesthetic design of graphics. I believe that nature serves as a great backdrop to the screen I've created. With this said, I believe that a building can blend in with the environment, but the focus was on an architectural system, and a building that would contribute to the landscape, but stand out among nature.

I think because of the idea of giving back to nature, but creating an architectural screen with presence that I would be able to let viewers know where the focus of my design intent was. I believe that the screen creates a great presence on the site, as well as a great contrast and presence in the landscape.

BIBLIOGRAPHY

Christo. *Christo Prints and Objects, 1963 - 1987 : A Catalogue Raisonne*. Edited by Jorg Schellmann and Josephine Beneke; introduction by Werner Spies. Edition Schellmann: Abbeville Press, 1988.

Christo. *Christo & Jeanne - Claude: Early Works 1958 - 1969*. New York: Taschen; Koln, 2001. pg. 198 - 203.

Christo's Valley Curtain. Film By Albert Maysles, David Maysles, and Ellen Hovde. Videorecording. New York: Maysles Films, 1974.

Donovan, Molly. *Christo & Jeanne - Claude, In the Vogel Collection*. National Gallery of Art, Washington: Harry N. Abrams, Inc., Publishers, 2002. pg. 62 - 64, 67 - 70, 98 - 100, 106 - 109.

Fineberg, Jonathan. *On the Way to the Gates, Central Park, New York City, Christo & Jeanne - Claude*. New Haven & London in association with Metropolitan Museum of Art New York: Yale University Press, 2004.

Frampton, Kenneth and Anthony C. Webster; edited by Anthony Tischhauser. *Calatrava bridges*. Basel; Boston: Birkhauser Verlag, 1996.

Tazonis, Alexander and Liane Lefavre. *Movement, structure, and the work of Santiago Calatrava*. Basel; Boston: Birkhauser, 1995.

Watts, Andrew. *Modern Construction Handbook*. New York: Springer; Wein, 2001.

APPENDIX

CHRISTO AND JEANNE-CLAUDE, OVER THE RIVER, PROJECT FOR ARKANSAS RIVER COLORADO, 2000

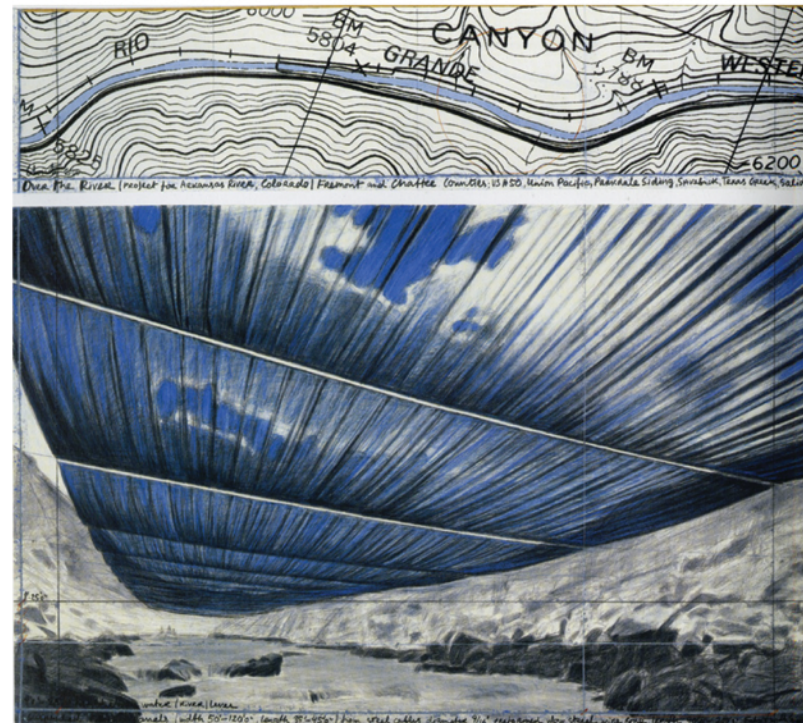
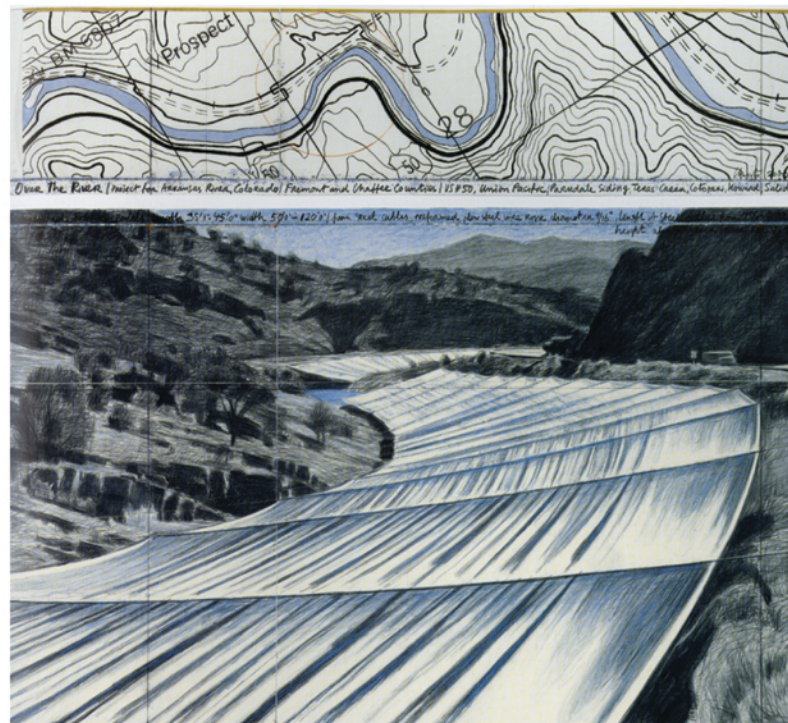

Donovan, Molly. *Christo & Jeanne - Claude, In the Vogel Collection*. National Gallery of Art, Washington: Harry N. Abrams, Inc., Publishers, 2002. pg. 106 - 109.

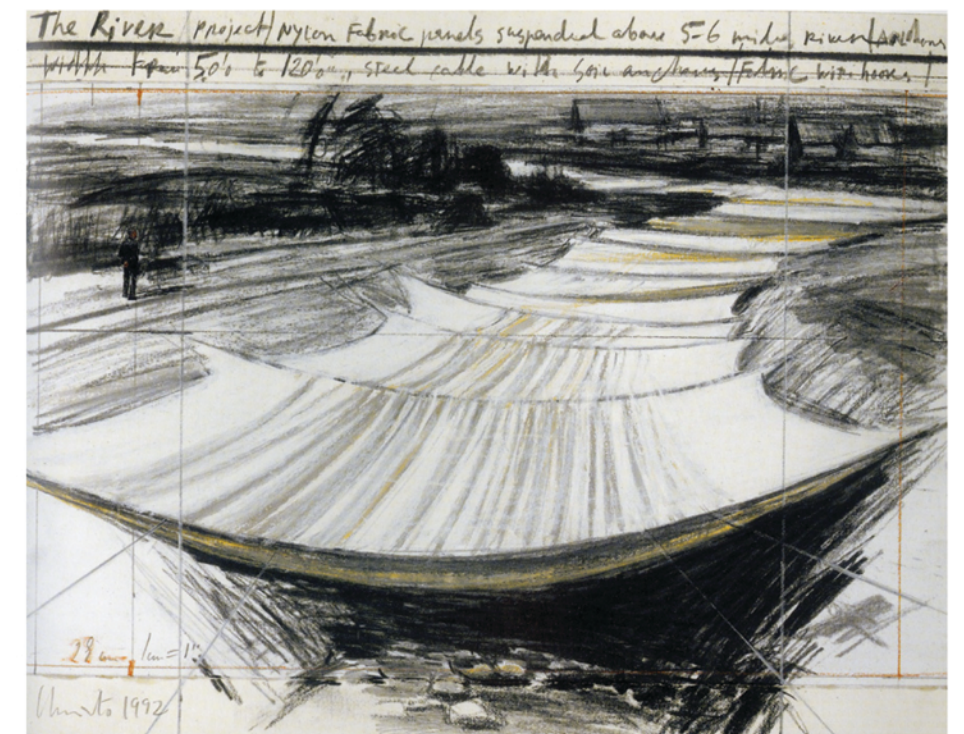

RUNNING FENCE, SONOMA AND MARIN COUNTIES, CALIFORNIA, 1972-76

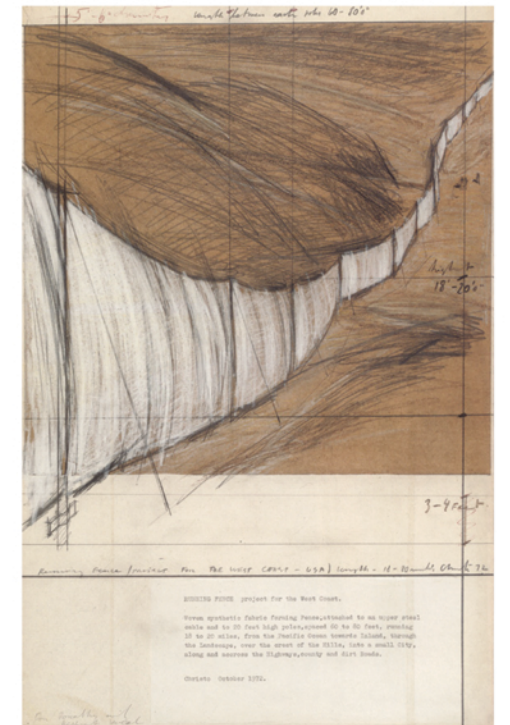

Donovan, Molly. *Christo & Jeanne - Claude, In the Vogel Collection*. National Gallery of Art, Washington: Harry N. Abrams, Inc., Publishers, 2002. pg. 67 - 70.

WRAPPED TREES, PROJECT FOR THE FOUNDATION BEYELER, RIEHEN, SWITZERLAND, 1997

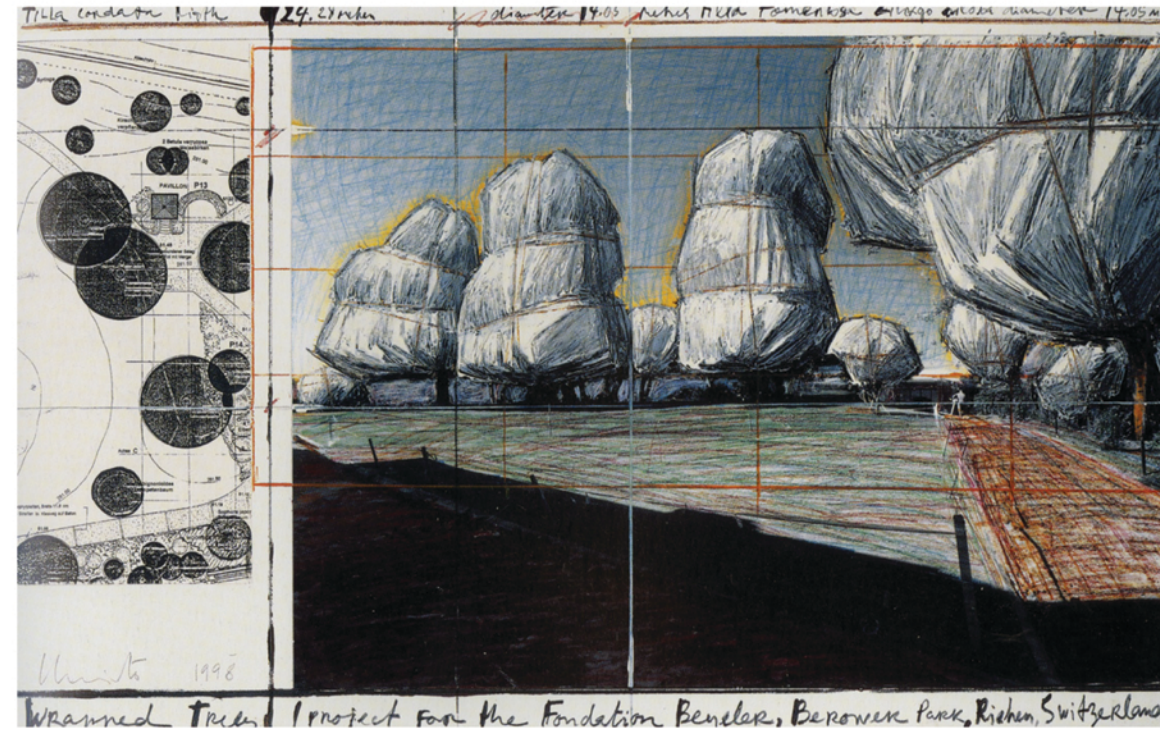

Donovan, Molly. *Christo & Jeanne - Claude, In the Vogel Collection*. National Gallery of Art, Washington: Harry N. Abrams, Inc., Publishers, 2002. pg. 98 - 100.

380 WRAPPED TREES, PROJECT FOR AVENUE DES CHAMPS ELYSEES, PARIS 1969

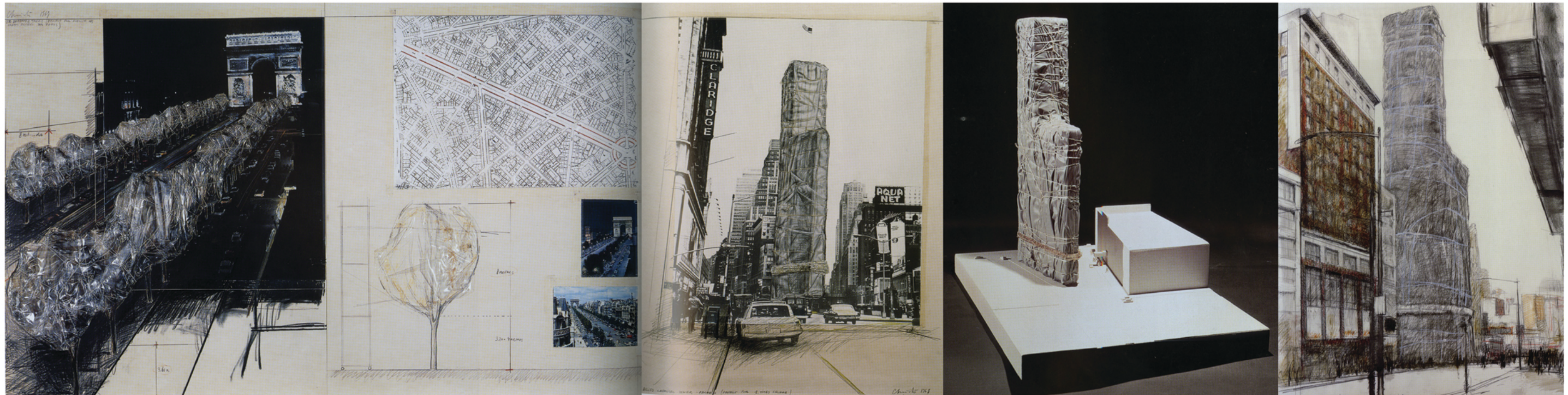

ALLIED CHEMICAL TOWER PACKED, PROJECT FOR #1 TIMES SQUARE, 1968

Christo. *Christo & Jeanne - Claude: Early Works 1958 - 1969*. New York: Taschen; Köln, 2001. pg. 198 - 203.

PACKED COAST, PROJECT FOR AUSTRALIA, NEAR SYDNEY, 1969



Donovan, Molly. *Christo & Jeanne - Claude*, In the Vogel Collection. National Gallery of Art, Washington: Harry N. Abrams, Inc., Publishers, 2002. pg. 62 - 64.

VITAE

ROBERT C. SIKORSKI

EDUCATION

Virginia Polytechnic Institute and State University

Blacksburg, VA

Master of Architecture

FALL 2004 - SPRING 2007

State University at Buffalo New York

Buffalo, NY

Bachelor's of Science in Architecture

2000 - 2004

RELEVANT EXPERIENCE

SFCS INC.

305 South Jefferson Street

Roanoke, VA 24011

Architecture Intern

Associate AIA