

## Design Process

### Original Intentions

The project program started as a dance club only which would incorporate a dance floor, bar, sitting area, lobby, restrooms and administration offices. The project occupied a small site that would accommodate such program and the intentions focused on the creation of a building that would emphasize the corner and, at the same time, give a doorway to the university. Ideas of looking back, or returning through its own steps, were considered as a response to these conditions. The decision to take over the whole block came as a response to the site analysis and the realization of the opportunities an entertainment center would have for the larger community.

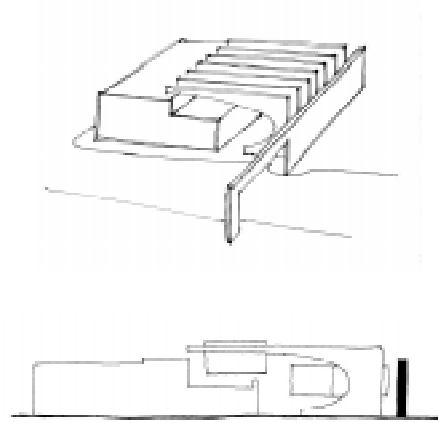
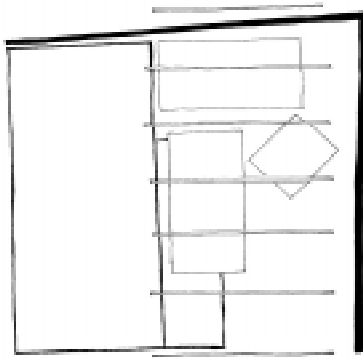

Original intentions of a corner and doorway to the university.

Enlarging the project to occupy the whole block compliments further this idea of transition, not only with the peoples point of view but the architectural scale as well.

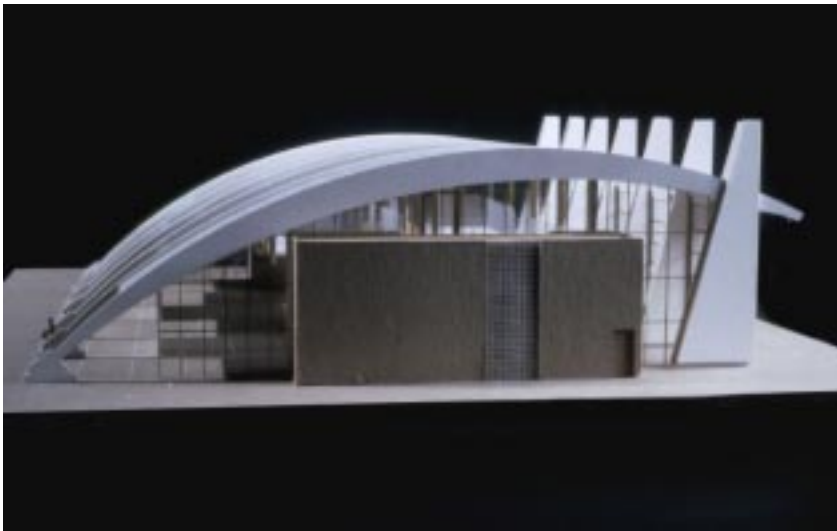

The structure as a shell leave a lot of opportunities to the functions inside.

Case studies of entertainment centers emphasize the idea that time affects everything. Trends and fashion are not only conditions for clothing, but also for architecture. Therefore the basic structure of the building should be a shell where the interior fittings can be changed, making the space flexible such that future generations can customize it to their own needs.

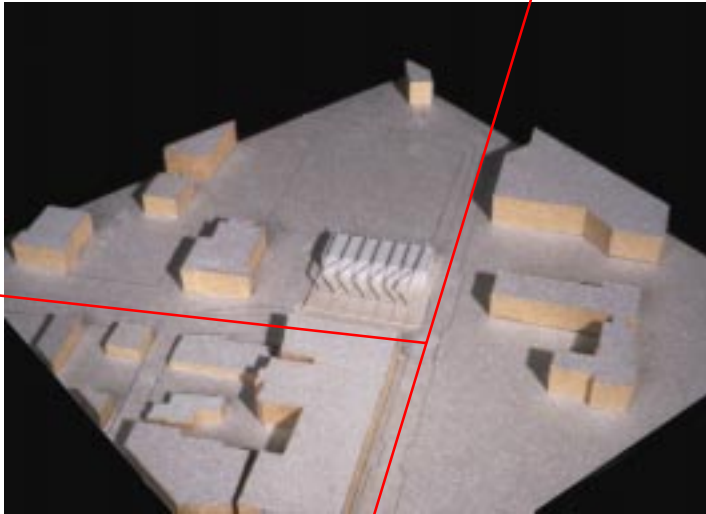

(a)

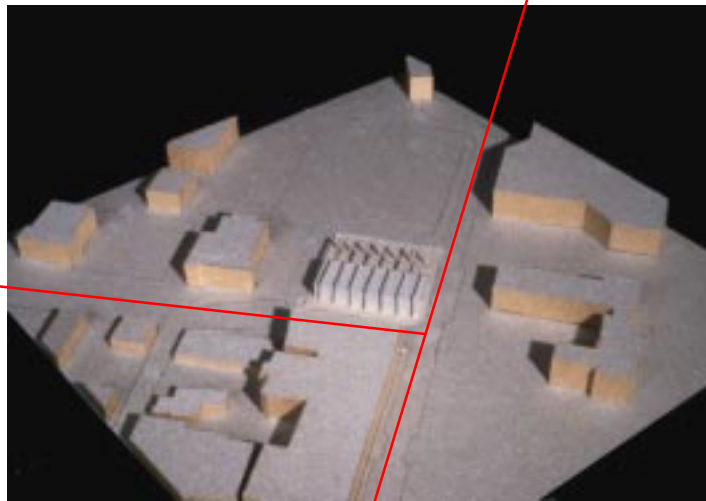

(b)

## Orientation

Different orientations were explored to achieve the condition of gateway to the university campus:

Initially a plaza was offered to expand Draper Road (a) as a possibility to expand toward College Avenue and inside the perimeters of the building in front of the site, Henderson Hall. The building created the barrier between the university parking and these new open space. This orientation, would not offer the gateway condition desired between town and university; it would actually isolate more both locations.

Offering the plaza to the university parking lot (b) did not give any different option as to the intentions of the building, so considerations of focusing the structure perpendicular toward the primary transited street was the next logical observation.

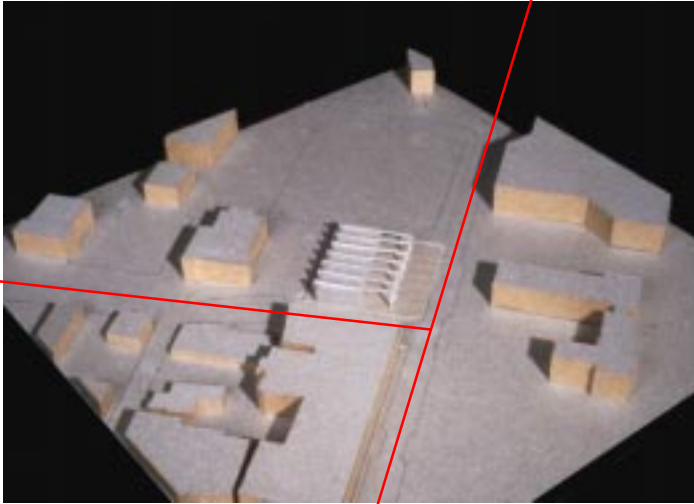

(c)

To focus the building to the back of the site (c) was a solution that might be considered, but with the conditions of the site the building was separating two areas that together could offer a difference in the realization of the building.

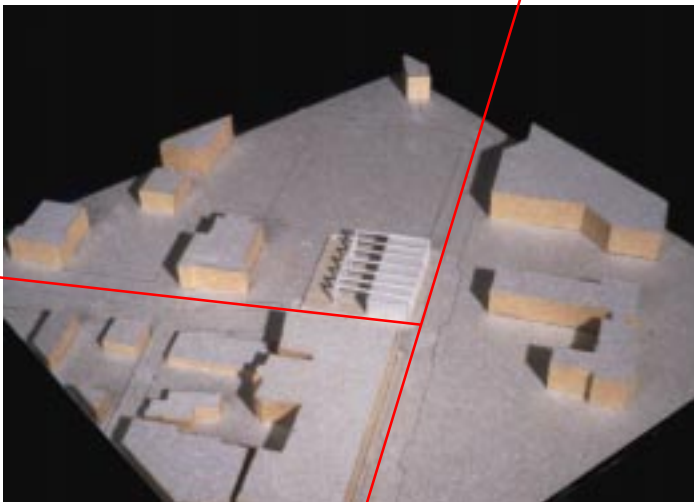

(d)

To locate the building facing the street (d) it offered a linear character that is also present on the adjacent buildings being the structure as a strong vertical line that emphasizes the entrance to the university, and at the same time offers a directional focus toward the street.



Looking from Draper Road toward College Avenue

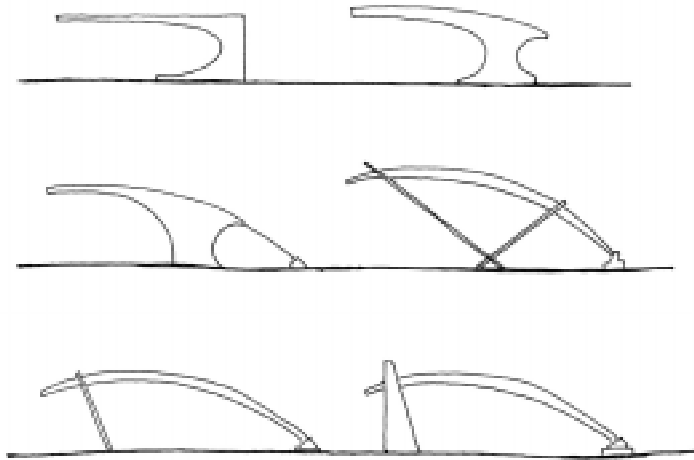

Structural development.

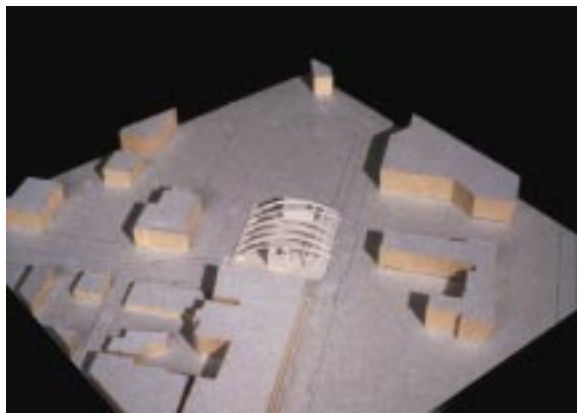

Curve intention at site.

## Flexibility

The type of structure had many options since the beginning of the project. The initial intention of returning through their own path, as an end of the street, was important. But when the project became bigger, concerns of structural support became priorities. The way they relate to each other was a process of study, being at the beginning my concern of the appearance of this building and, later on, the structural factor of it. I looked at all of them together, I realized that the structure had been changing from a *shape* to a *form*. Shape “refers to the edge contour of a plane or the silhouette of a volume” and form refers to a formal structure of the work or subject.

Form consist of a various of properties such as, shape, size, color, texture, position, orientation and visual inertia, but all of these are “affected by the conditions in which we view them” according to angle of vision, distance, lighting and visual field.

The curve has the intention of acting as a dynamic representation of the functions of the building. To an entertainment center, it lends itself as a longspan structural system that achieves freedom and flexibility for the interior of the building. The curve also was intended to give the building a unique self-identifying appearance that even though generated by conditions of both sides of the town, has its own spirit that comes from both as a copy of neither... a transition architecture.

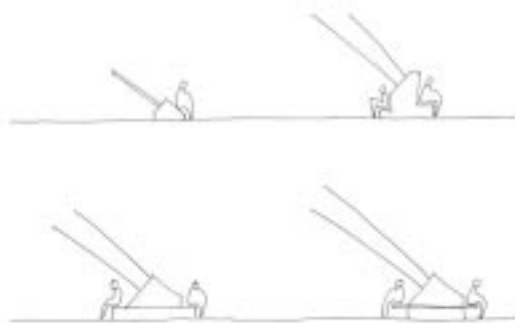
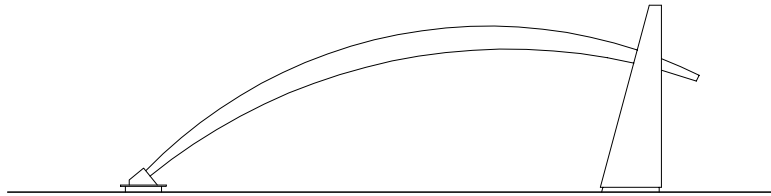

Anchor as a sitting place.

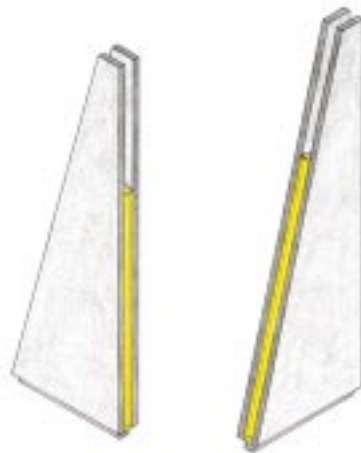

Column as a light fixture.

## Exterior structure

Structurally the building consists of a series of concrete beams anchored to the floor and columns that set the boundaries of the building as a shell that can accommodate other entertainment functions in the future. This shell consists of a curved beam with a radius of 118 feet, where the start point is located at 71 degrees, and the end point at 129 degrees. The length of this beam is 120 feet, and its span goes to 100 feet.

Concrete as the anchor gave a strong effect of strength and its beam component, having an opportunity to create a fusion between them. A secondary function as a sitting area was incorporated as part of the solution as a response to the surrounding area, especially with the location of the cafes and restaurants.

Light fixtures toward the interior and exterior of the building will inhabit the concrete column supporting the beam. Thus creating a secondary function that will not only benefit the building, but the street itself.

## Interior structure

To incorporate this idea on the second level, the second level support, consist of steel hangers that will be attached to the primary concrete beam. The suspended secondary steel beam will support the precast floor of the second level.

Different types of connections to the beam were suggested to create a better and different support. Connections to the floors were also considered simultaneously with the concrete beam connection to offer more stability to the upper rooms. Lateral forces has to be consider to create this stability in the floors, the reponse to this situation was to conect structurally the steel hangers creating a diagonal support between them.

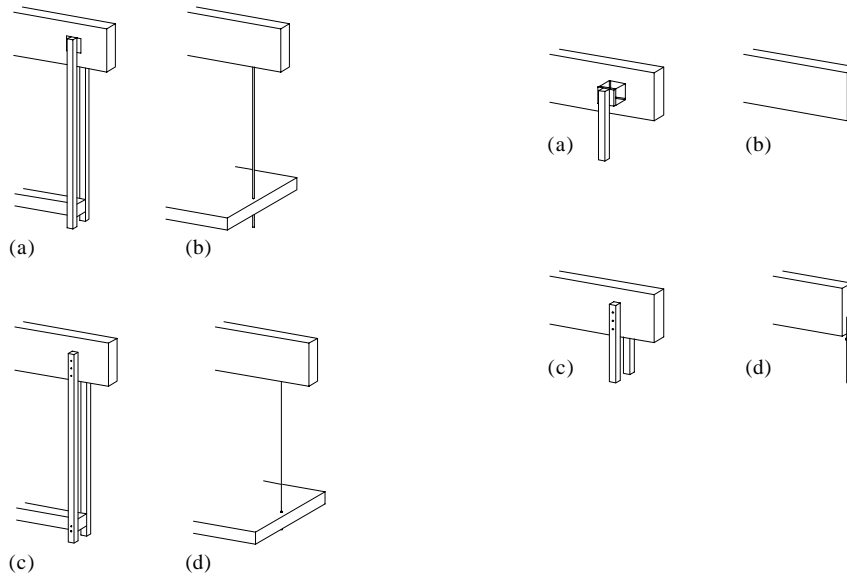

Conection options to beam and floor: (a) welded, (b) rod, (c) screwed, and (d) tension cable.

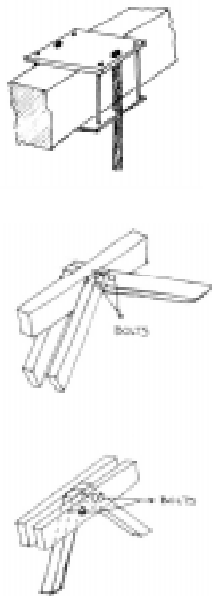

Other options.

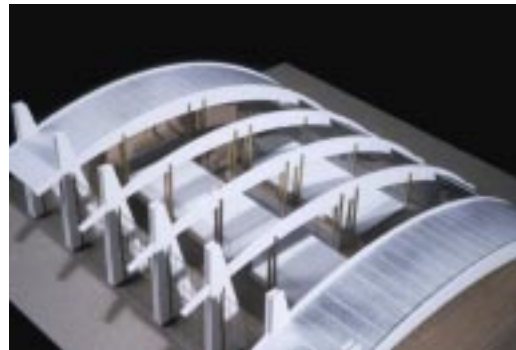

The screwed option was the more effective for the situation.



Looking from College Avenue toward the University

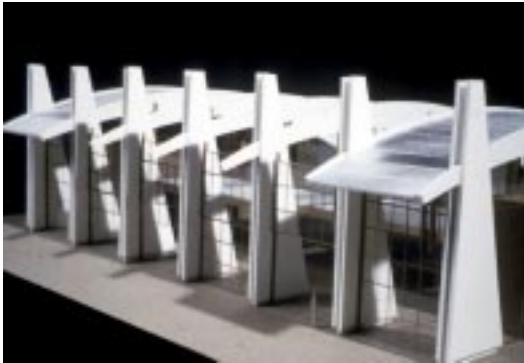

Rear wall intentions.

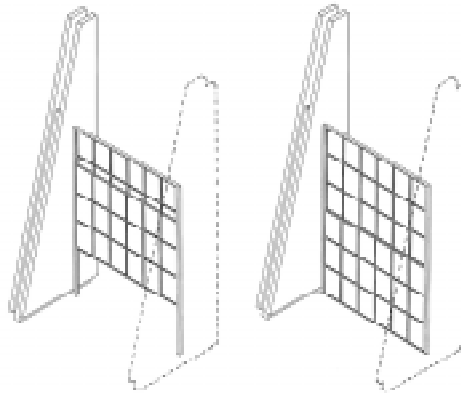

## The front and rear walls

The front wall toward the street is a glass wall located between the concrete columns. They have the ability to move up to open the lower space making the building a big open area. For security reasons it is necessary to have conventional side-hinged doors to access the exterior without any mechanical system, two lobbies/lounges are located between the last two columns at each end as a result of this necessity.

The rear wall has the same intentions of opening up the first floor, but its material and mechanism are different. This wall is metal to give more privacy toward the garden-parking of the building. But it has the mechanism to rise toward the roof to become part of it, which in turn opens the space whenever necessary.

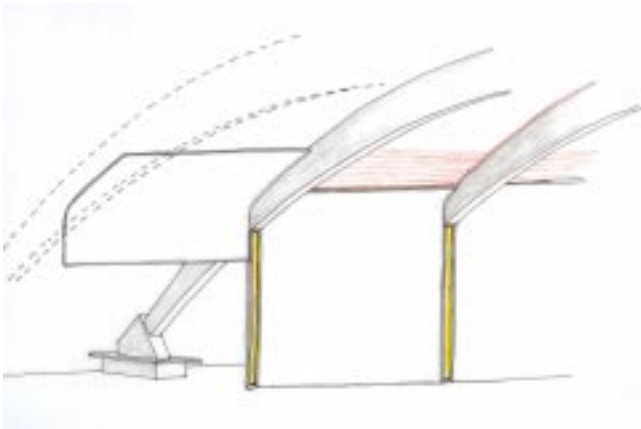

The metal wall toward the parking raises up to open the space.

The support of this wall runs through the sides of the beams, leaving an open space underneath. A light was design to have a complete closure to the building.

## Circulation

The enclosure walls were designed to open up toward the street and make the first floor of the building part of the street, thus generating a covered plaza.

This condition should be viable and adopted by the town with good eyes, considering such activities as the International Fair, Steppin' Out Fair, and any similar activities.

These space could be incorporated with the outside for any event whenever necessary allowing open circulation through the lower level of the building.

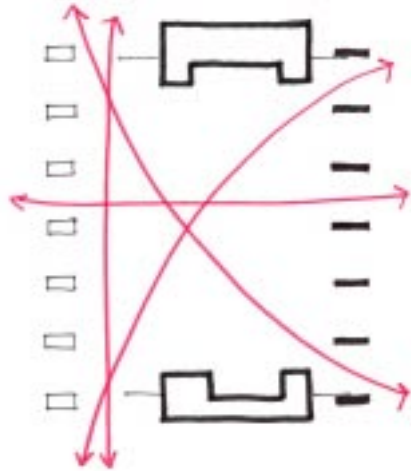

Circulation diagrams in plan and section.

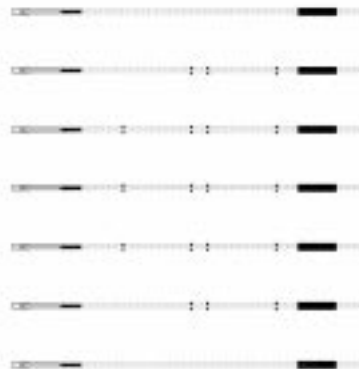

Structure diagram

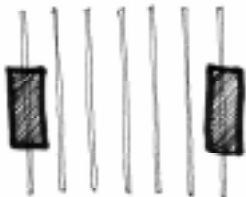
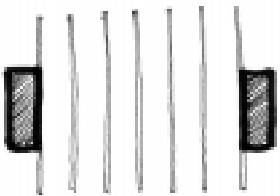
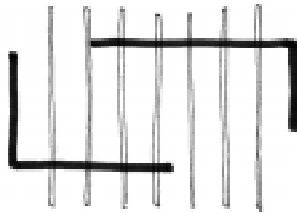

Bookend conditions in plan.

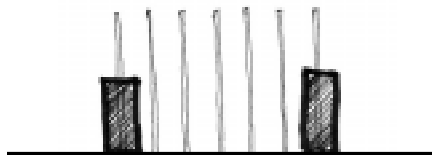
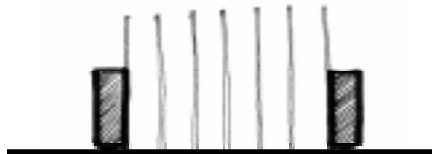
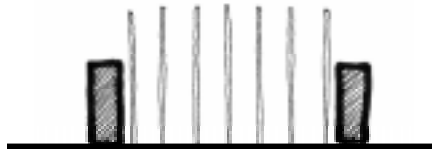

Bookend conditions in elevation.

## Ending a repetitive Structure

The tectonic resolution came as a repetitive structural form which offers the advantage of construction. The appropriate ending to a repetitive structure became the next major design consideration. Thoughts of walls as a unifying element came to mind, but it was the idea of a bookend that gave me a workable answer.

The program and location for these bookend elements and how they interact with the structure became another consideration. Tension between these elements was a factor to consider as a unifying piece.

The solution came down to which one offered the best response to this conditions. Its connection to the structure in elevation was the key, giving the impression of pressure between elements.



Looking toward the front elevation at College Avenue

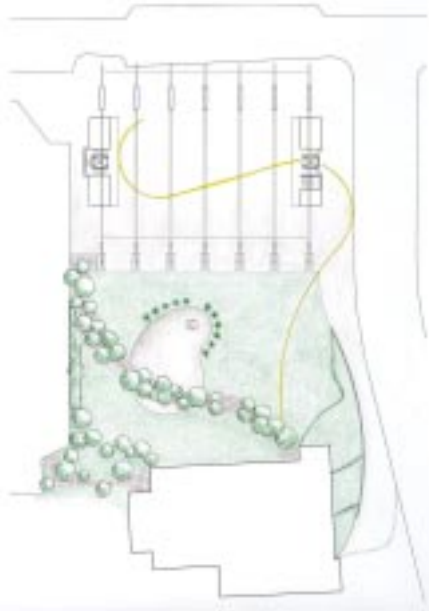

Garden Design (a)



Parking- Garden (b)



Parking- Garden (c)



Parking- Garden (d)

## Parking area

The design of parking is something that many people ignore because this area is only needed for functional reasons and it is a place used only in specific times of the day, so afterwards this area is lost, since they don't bring anything to the community. My intention was to create a space that, during off hours can be used as a sculpture garden, integrated to the building and continuity.

The studies started with the thoughts of a garden design (a) that will connect the adjacent buildings and emphasize the paths through the site.

To integrate the building as part of the parking-garden (b) lights were design as if the concrete beams would open the earth and offer clarity to the area with floor lights. But the materials desired were still typical methods of paving.

The first floor paving was considered as part of the integration process, with a concrete tile of eight by eight feet, in two consecutive rows between the beams that will continue through the parking-garden (c), giving the option of marking different areas for setting tables in the inside and outside of the building, if desired.

Parking (d) arrangement was considered to offer a maximum capacity for the town and can also be used as open gallery space for the world of the students of the adjacent art school.

Perhaps the combination of cars and art would also become another point of transition between the mundane function of parking and the more elevated concept of outdoor sculpture.