

2.0 System Description

The wireless alarm system consists of two or more alarm units within a specified range of one another. Each alarm unit employs a radio transceiver, allowing it to communicate with other units in the system. When a unit detects an alarm condition, it sounds a horn and broadcasts an alarm message. Alarm units that are within range receive the alarm message, sound their horns, and then retransmit the message for other units to receive. This process continues until all of the units in the system have received the alarm message. This retransmission strategy allows a single alarm unit to ultimately trigger the alarms of all units in a given system.

The alarm units communicate additional information in a similar fashion. All units have both a test and a reset button. When a user presses the test button on a given unit, it sounds its test horn and broadcasts the test message throughout the system. Pushing the reset button causes a unit to disable its horn and to initiate the transmission of a reset message so that all units in the system ultimately disable their respective alarms.

An example of the retransmission strategy employed by the wireless alarm system is shown below in Figure 2.1.

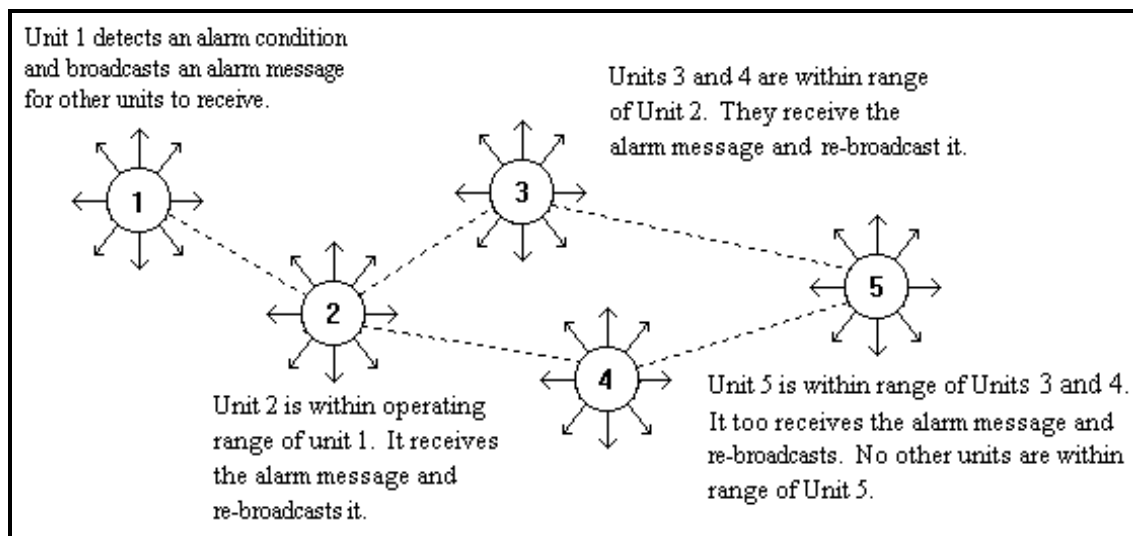

Figure 2.1: Example Operation of the Wireless Alarm System

2.1 Functional Specifications

The wireless alarm units operate in one of eleven possible modes at any given time[6]. Each of the eleven modes of operation along with their respective purpose and function are discussed below.

2.1.1 Standby

Units operate in standby mode when battery power is applied. In standby mode, units are capable of detecting an alarm condition, receiving messages, responding to user button presses, and testing the battery. In standby mode, units may transition to another mode

given the detection of a relevant condition. Possible modes to which units may transition are summarized in Figure 2.2. Note that the circles in the figure represent the modes of operation, while the labeled arrows represent the event which causes the transition.

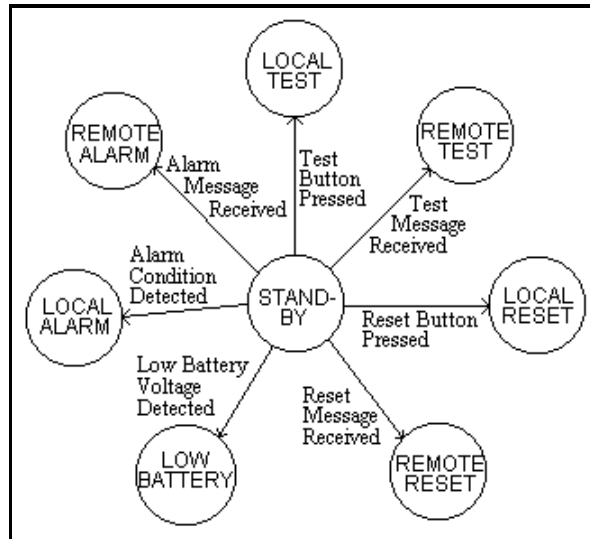

Figure 2.2: Possible Transitions from Standby Mode

2.1.2 Local Alarm and Remote Alarm

Units transition into an alarm mode when an alarm condition is detected or when an alarm message is received from a remote unit. When in either the local or remote alarm modes, a unit sounds its horn and retransmits the alarm message for other units to receive. In addition, the unit’s receiver is activated so that the unit can receive reset messages. Units exit the alarm mode during either a reset condition or a low battery condition. The causes of transition from the alarm modes to other modes are shown in Figure 2.3.

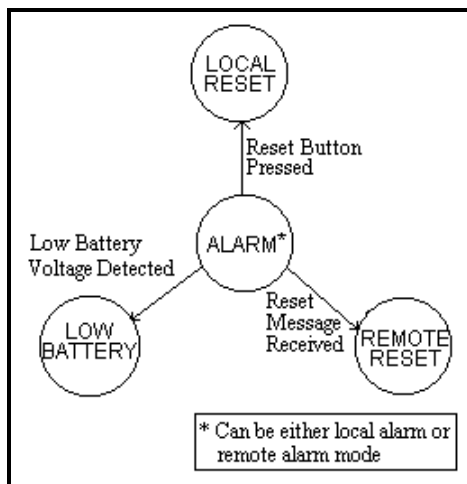

Figure 2.3: Possible Transitions from Local and Remote Alarm Modes

2.1.3 Local Test and Remote Test

The wireless alarm units offer testing capabilities to the user. The user can initiate system testing by pressing a test button on a single unit. When a unit's test button is pressed, the unit enters local test mode. While the test button is pressed, the unit sounds its horn and transmits a test message to other units. Units which receive the test message enter remote test mode.

Units in local test mode enter a wait mode when the test button is released. Units in remote test mode enter a wait mode after sounding their horn, retransmitting the test message to other units, and listening for RF messages on the channel. If a unit in remote test mode receives a reset message, the unit transitions into remote reset mode. Figure 2.4 demonstrates these activities.

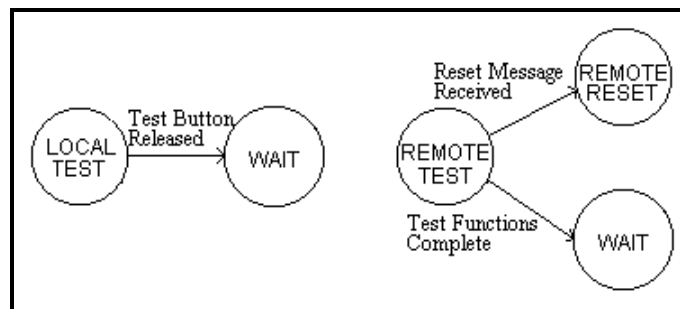

Figure 2.4: Possible Transitions from Local and Remote Test Modes

2.1.4 Local Reset and Remote Reset

Local reset mode is entered when a unit's reset button is pressed. Remote reset is entered when a unit receives a reset message from another unit. While in either local or remote reset mode, units can react to local alarm conditions. Under normal conditions, units go into wait mode following reset mode. Figure 2.5 demonstrates the possible transitions from reset mode to other modes. Note that in remote reset mode, units also test the battery voltage.

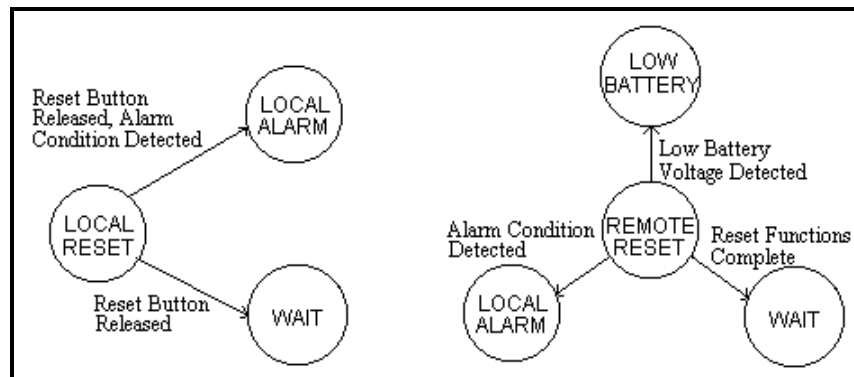

Figure 2.5: Possible Transitions from Local and Remote Reset Modes

2.1.5 Low Battery

Alarm units enter a low battery mode when the battery voltage becomes too low. During low battery mode, units sound a horn to indicate the low battery condition. Variations in voltage may cause units in low battery mode occasionally to transition to other modes. However, as battery conditions worsen, units remain in low battery mode until the battery is completely depleted.

2.1.6 Wait

The wait mode is entered after the transmission of a reset message or a test message. During wait mode, units continue to test for alarm conditions and for low battery voltage. However, the receiver of a unit in wait mode is disabled so that feedback will not cause continuous retransmission of messages. Units enter standby mode after a time delay. The operation of units in wait mode is shown in Figure 2.6.

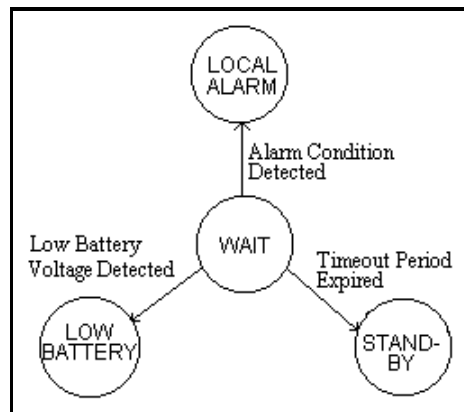

Figure 2.6: Possible Transitions from Wait Mode

2.1.7 Remote AUX2 and Remote AUX3

The remote AUX2 and remote AUX3 modes are reserved for future applications in the alarm system. Since they are not currently used, their functionality is not discussed.

2.2 Technical Specifications

Each wireless alarm unit has a radio transceiver for communication with other units. The EIRP is -41.10 ± 4 dBm, while the receiver sensitivity is -105.5 dBm.

Binary messages are transmitted at a carrier frequency of 418 MHz. An amplitude shift keying (ASK) digital modulation scheme is employed. The modulation scheme uses two signal states, mark and space. The presence of the carrier signal denotes a mark, while absence of the carrier denotes a space. The binary messages are Manchester encoded such that a *one* symbol is represented by a mark to space, while a *zero* symbol is represented by a space to mark.

Information in the alarm system is transmitted at 1 kbps. Messages are 16 bits long and have the format shown in Figure 2.7. The most significant bit of each message is transmitted first.

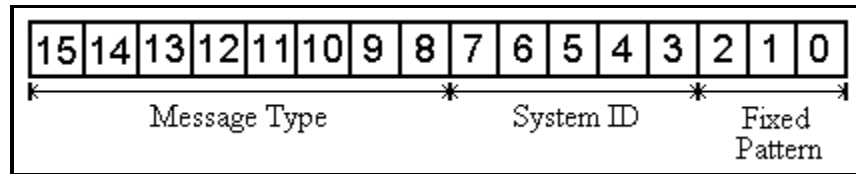

Figure 2.7: Message Format of the Wireless Alarm System

The first eight bits of each word are reserved for the message type. Message types, and their respective codes are summarized below in Table 2.1.

Table 2.1: Wireless Alarm System Message Codes

Message Type	Binary Code
ALARM	10111000
TEST	00011101
RESET	01000111
AUX2	11100010
AUX3	01110100

The next five bits of data are reserved for the system identification number. Each alarm unit has five dip switches which can be configured to allow up to thirty-two alarm systems to operate independently in close proximity of one another. In order for an alarm unit to consider a received message to be valid, the system identification code in the message must match the dip switch settings of the receiving unit.

The last three bits in every data word are a fixed pattern, 110.

2.3 Transceiver Operation

The wireless alarm units share a common radio channel for communication. To prevent message collisions, a Carrier Sense Multiple Access (CSMA) scheme is used. When a unit is ready to transmit, it senses the channel by checking the output of its receiver for Manchester encoded data. If the unit determines that the channel is idle, it transmits its message continuously for 24 seconds.

It is apparent that if two units detect the channel idle at the same time, the continuous retransmissions are pointless, as both units will transmit simultaneously and their messages will collide. To alleviate this problem, each unit employs a holdoff timer. When a unit senses the channel, its receiver is enabled, and receiver output is only tested each time the holdoff timer expires. It is desirable for each unit to have a different value in its holdoff timer at any given point in time. Each unit's holdoff timer is initialized when power is applied to the unit. The holdoff timer increments every 93.75 ms and expires every 6 sec.

In order to preserve battery life, the receiver in each unit is only enabled periodically. The time interval or *receive window* during which alarm units can receive and decode a

message lasts for 93.75 ms every 18.84375 s. This is depicted below in Figure 2.8. Note from the figure that the receiver is actually activated for a period of 187.5 ms every 18.75 s. However, the first half of this interval is reserved to allow the receiver to stabilize. The decoder is not enabled until the second half of this time period.

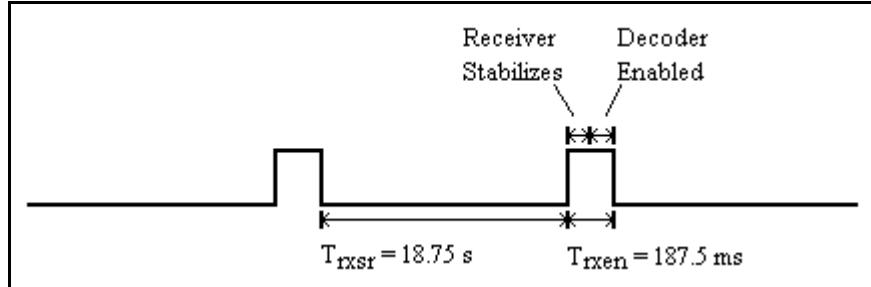

Figure 2.8: Timing of Receiver Activation

The validity of a received message is determined by three criteria. First, the message must be received two or more consecutive times during the receive window. In addition, the system ID field must match the settings of the receiving unit's dip switches. Thirdly, the message must contain a valid message field. Invalid messages are simply ignored.

2.4 System Delays

It was previously mentioned that receivers in the wireless alarm system wake up only periodically. Although this periodic wakeup feature allows the units to conserve battery life, it also causes system delays.

The time required for a remote unit within range of an originating unit to begin sounding its alarm is the unit to unit alarm/test latency. The maximum unit-to-unit alarm/test latency is specified as 18.75 s, while the typical value is 9.38 s.

The time required for the last unit in a serial array of units to sound its alarm is the alarm/test propagation time. The maximum and typical alarm/test propagation times are given by equations (2.1) and (2.2).

$$\textit{Maximum: } 30(N - 2) + 18.75\text{sec} \quad (2.1)$$

$$\textit{Typical: } 27(N - 2) + 9.38\text{sec} \quad (2.2)$$

where N is the number of units in the system.

The alarm propagation interval is defined as the time delay from when the first unit in a system begins sounding its alarm to when the last unit in the system completes its transmissions of the alarm message. The alarm propagation interval is given by equation (2.3).

$$\textit{Maximum: } 6 + 24N \text{ sec} \quad (2.3)$$

where N is the number of units in the system.