

**EXPERIMENTAL INVESTIGATION OF REPAIRED REINFORCED
CONCRETE HIGHWAY BRIDGE COLUMNS**

by

Rodney Simon

Project submitted to the Faculty of the
Virginia Polytechnic Institute and State University
in partial fulfillment of the requirements for the degree of
MASTER OF ENGINEERING
in
Civil Engineering

APPROVED:

Richard M. Barker, Chairman

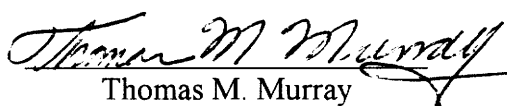
Thomas M. Murray

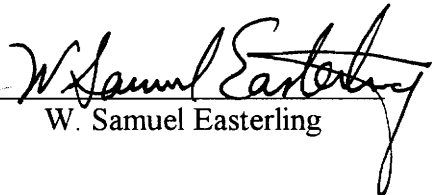
W. Samuel Easterling

July, 1994

Blacksburg, Virginia

C.2

LD
5055
4851
1994
5566
C.2

**EXPERIMENTAL INVESTIGATION OF REPAIRED REINFORCED
CONCRETE HIGHWAY BRIDGE COLUMNS**

by

Rodney Simon

Chairman: Dr. Richard M. Barker

Department: Civil Engineering

(ABSTRACT)

The following report is a pilot study intended to determine the effectiveness of repaired reinforced concrete highway bridge columns. Four scaled down columns were designed, built and tested to determine behavior and ultimate strength. Each specimen had a different configuration corresponding to various stages of deterioration and repair. Data recorded consists of axial deflection and concrete strain along with axial load. Comparisons of the specimens were made to determine the differences in behavior and ultimate strength. Results have indicated strength is fully restored, however it is recommended further study be conducted for a stronger verification.

Acknowledgments

The author would like to thank Dr. Richard M. Barker for serving as committee chairman of this project along with Dr. Thomas M. Murray and Dr. W. Samuel Easterling for serving as committee members. My committee has been excellent throughout my graduate education.

The author would also like to thank Mr. Brett Farmer and Mr. Dennis Huffman for their assistance in the laboratory.

Appreciation is extended to Mr. and Mrs. Russell Simon, Mr. and Mrs. Bob McLaughlin and Mr. Rex Simon for their continued support of my education.

Table of Contents

Abstract	ii
Acknowledgments	iii
List of Figures	v
List of Tables	vi
Chapter I Introduction	1
1.1 General.....	1
1.2 Problem Statement	2
1.3 Scope	3
Chapter II Specimen Development.....	4
2.1 General.....	4
2.2 Specimen Design	4
2.3 Specimen Construction.....	6
2.4 Specimen Instrumentation.....	7
Chapter III Experimental Program	9
3.1 General.....	9
3.2 Testing Apparatus	9
3.3 Data Acquisition.....	10
3.4 Testing Procedures	11
Chapter IV Results and Discussion	13
4.1 General.....	13
4.2 Material Properties	13
4.3 Specimen A: Trial.....	15
4.4 Specimen B: Control	16
4.5 Specimen C: Un-Repaired	19
4.6 Specimen D: Repaired	21
4.7 Summary	22
Chapter V Conclusion and Recommendations	27
5.1 General.....	27
5.2 Conclusions.....	27
5.3 Recommendations	28
References	29
Appendix	30
A.1 Nomenclature	30
A.2 Load Procedures	30
A.3 Reinforcement Data.....	32
A.4 Sample Calculation.....	32
Vita	33

List of Figures

Figure	Title	Page
2-1	Test Specimen	6
2-2	Strain Gage Locations	8
3-1	Test Setup	12
4-1	Specimen B: Axial Load vs. Head Displacement	17
4-2	Specimen B: Axial Load vs. Concrete Strain	18
4-3	Specimen C: Axial Load vs. Head Displacement	19
4-4	Specimen C: Axial Load vs. Concrete Strain	20
4-5	Specimen D: Axial Load vs. Head Displacement	21
4-6	Specimen D: Axial Load vs. Concrete Strain	23
4-7	Axial Load vs. Head Displacement (Specimens B and D)	24
4-8	Axial Load vs. Concrete Strain (All Specimens)	25
4-9	Axial Load vs. Concrete Strain (Specimens B and D)	26
A-1	Stress vs. Strain (Main Reinforcement)	32

List of Tables

Table	Title	Page
2-1	Casting and Testing Dates	7
4-1	Material Properties	14
4-2	Specimen Strength	15
4-3	Strength Comparison	24
5-1	Strength Comparison (Specimens B and D)	27

CHAPTER I

INTRODUCTION

1.1 General

Over half of the 600,000 highway bridges in the United States were built before 1940. At the time, design parameters were considerably different than what they are today. Most bridges were designed for less traffic, smaller vehicles, slower speeds and lighter loads. Design engineers assumed concrete would last forever therefore maintenance programs lacked the required resources to keep bridges in the appropriate condition. According to the Federal Highway Administration (FHWA), nearly 40 % of the highway bridges are deficient and in need of rehabilitation or replacement. Studies have indicated, it is cost effective to strengthen the existing structure rather than reduce the allowable load (Planck et al., 1993). With the lack of maintenance and repair, deterioration is widespread. Various factors may contribute to the demise of concrete including marine environments, high chloride content in the air and the use of deicing salts. Poor design or construction also plays a significant role in the deteriorating bridge conditions.

Many structural elements are contained within a bridge system. Two of the primary elements are bridge decks and the piers or columns. The bridge deck consists of the roadway along which vehicles travel. Bridge deck girders are used to support the roadway and may be made of steel or reinforced concrete. The bridge deck may also contain walkways or bike paths, lighting and parapet walls or railings to provide safety for the users. The piers transfer the loads to the ground. These along with other structural members may be subject to strength reduction by natural or physical means, including

corrosion or impact from vehicle accidents. The material in this study focuses on the strength effects of rehabilitated reinforced concrete bridge columns.

A present method widely used for rehabilitation of bridge piers is the use of a cylindrical steel casing. This casing is placed around the existing bridge pier and grout is usually pumped into the gap between the two so as to create a constraining effect. Proper installation of the casings is time consuming and difficult (Karbhari et al., 1993).

Another method presently being studied, is the use of resin infused composite wraps. Studies have been performed where concrete column stubs have been wrapped with fabric and impregnated using a resin infusion technique (Karbhari et al., 1993). It was reported there was a significant increase of load carrying capacity, depending on the amount of fabric used and the treatment of the existing material.

Another method used is to clean out any deterioration and to expose the reinforcement. Gunitite is then sprayed onto the affected section and allowed to cure. In areas of excessively large deterioration, a form is built around the bridge column and the repair material is cast in place. It is assumed by engineers that full strength is restored.

The studies in this paper will concentrate on the structural effect of repairing a deteriorated concrete column with ready mix concrete by building a form around an existing specimen and casting the repair material.

1.2 Problem statement

With the increase in transportation and roadways there has been an increase in the dependency on bridges. A majority of the bridges in the United States were built more than fifty years ago. Today there is a serious problem with deteriorating bridges. There is a reduction in strength due the reduction in cross-sectional area of the supporting

elements. A primary question is how much strength is lost and if repaired is the strength fully restored. With the increase in cars on the road, heavier loads in tractor trailers, it is required that these bridges be 100 % of their design strength.

In Virginia, there is wide spread use of gunnite or casting of repair material upon deteriorated sections. Engineers assume the full strength has been restored, however there has been no evidence to back this up. This study seeks the answer to this question and others.

1.3 Scope

The information presented in this research is for a pilot study of repaired model highway bridge columns. The study consists of the development, fabrication and testing of four test specimens. The specimens were subjected to a static, compressive, axial load and were loaded to failure. The behavior of the specimens was studied to determine how the strength of a deteriorated section is affected, and when repaired, to determine if the strength was fully restored.

The four specimens, which were labeled Specimen A through Specimen D, consist of a trial, a control, a deteriorated and a repaired column. The intention of the trial specimen was to work any "bugs" out of the experimental program. The control specimen was one that contains no simulated deterioration, i.e. a column at 100%. The deteriorated specimen has been reduced to 81.3% of the gross cross-sectional area at the affected section, and to 94% of the total volume. The repaired specimen contains a void that has been repaired so as to attempt to regain the full strength.

CHAPTER II

SPECIMEN DEVELOPMENT

2.1 General

This chapter discusses the design, construction and instrumentation of the reinforced concrete column test specimens. The design of the specimen includes a discussion of the equations used for development. Fabrication of the specimens is discussed and also a description of how the specimen is instrumented.

2.2 Specimen Design

In designing the test specimens several parameters had to be considered. The primary parameter was to create the test specimens as near to real life conditions as possible. The procedure to repair the specimen was also developed to account for field conditions. The specimen was designed so failure would not occur by buckling. Equations used to compute the failure load assumed the full strength of the concrete and a 25% over stressing of the reinforcement. This was decided to ensure the failure load would be less than 300 kips to accommodate load application limitations. Other parameters considered were ease of construction and financial considerations.

To simulate actual field conditions all specimens were cast in the vertical state. Repairs were also cast in the vertical state. A concrete bonding agent was applied to the substrate to ensure a good bond between the substrate and the repair material.

To ensure the specimen was considered a "short" column, the slenderness ratio, Kl/r , had to be less than or equal to 22 according to Article 8.16.5.2.5 of the AASHTO

Specification (1992). With the selected cross-section, the maximum height of the specimen, assuming pinned-pinned conditions, was found to be approximately 48 in., which fell within height limitations of the testing apparatus.

The equation used to design the specimen is as follows

$$P_o = f'_c \times A_g + 1.25 \times f_y \times A_{st} \quad (2-1)$$

where

P_o = predicted failure load

f'_c = 28 day compressive strength of the concrete

A_g = gross area of the concrete cross-section

f_y = yield strength of the reinforcement

A_{st} = area of the steel reinforcement

The 1.25 factor is to account for the possible strength above the specified yield stress of the primary reinforcement. In the design procedure the concrete compressive strength was assumed to be 3 ksi, and the yield stress of the primary reinforcement was assumed to be 60 ksi. A 7.5 in. square cross-section was selected, with the primary reinforcement consisting of four number 4 rebar. By applying Eq. 2-1, the failure load was calculated as 229 kips for the control specimen. The selected height of the specimen was 48 in. or 4 ft. to ensure buckling would not occur. Number three ties were fabricated according to Article 8.23.2.2 of the AASHTO Specification (1992) and spaced 8 in. apart.

The square cross-section was selected for the ease of fabrication. Concrete forms were built with minimum time and effort. Placement and tying of reinforcement was

greatly simplified with the selected cross-section. Cost was also a consideration because the research herein was un-funded. Figure 2-1 indicates the specimen's configuration.

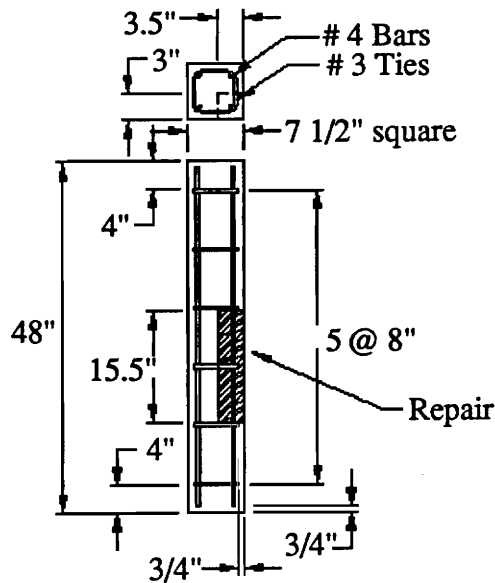

Figure 2-1 Test Specimen

2.3 Specimen Construction

Forms were built out of 3/4 in. plywood and two by fours. For specimens containing simulated deterioration, two by fours were built into the form to create a void when casting. Number three, Grade 40 rebar, used as ties, were bent to form a square shape and allow 3/4 in. concrete cover. Six ties spaced 8 in. apart were used in each specimen. The reinforcement for each specimen was fabricated outside of the form then secured inside the form.

Four specimens were cast. An attempt was made to obtain 3 ksi concrete for each test specimen. All specimens were cast in a vertical state and appropriate vibration

procedures were performed for each. To repair specimens with simulated deterioration, a form was constructed which allowed vertical casting of the repair material. The form also allowed development of a hydrostatic head in order to keep pressure on the repair material during the curing process. A ready to use packaged concrete mix was used for the repair material to ensure consistency. Table 2-1 indicates the dates of casting and testing the specimens.

Table 2-1 Casting and Testing Dates

Specimen	Casting Date		Testing Date
	Substrate	Rehabilitation	
A: Trial	9-15-93	10-18-93	2-16-94
B: Control	9-22-93	---	6-4-94
C: Un-Repaired	9-15-93	---	4-26-94
D: Repaired	9-22-93	10-18-93	6-6-94

2.4 Specimen Instrumentation

Each specimen was instrumented with a minimum of two and a maximum of four concrete strain gages. Due to the fact that this study revolves around the behavior of the repaired specimen, placement of the gages was based on it. The repaired specimen along with the control specimen contained four gages, one located on each face. The top of the strain gages were located 23 in. from the top of the specimen. This placed each gage at the top half of the repair, which was away from longitudinal reinforcement and any ties. This was to ensure accurate readings of concrete strain. See Fig. 2-2 for exact locations.

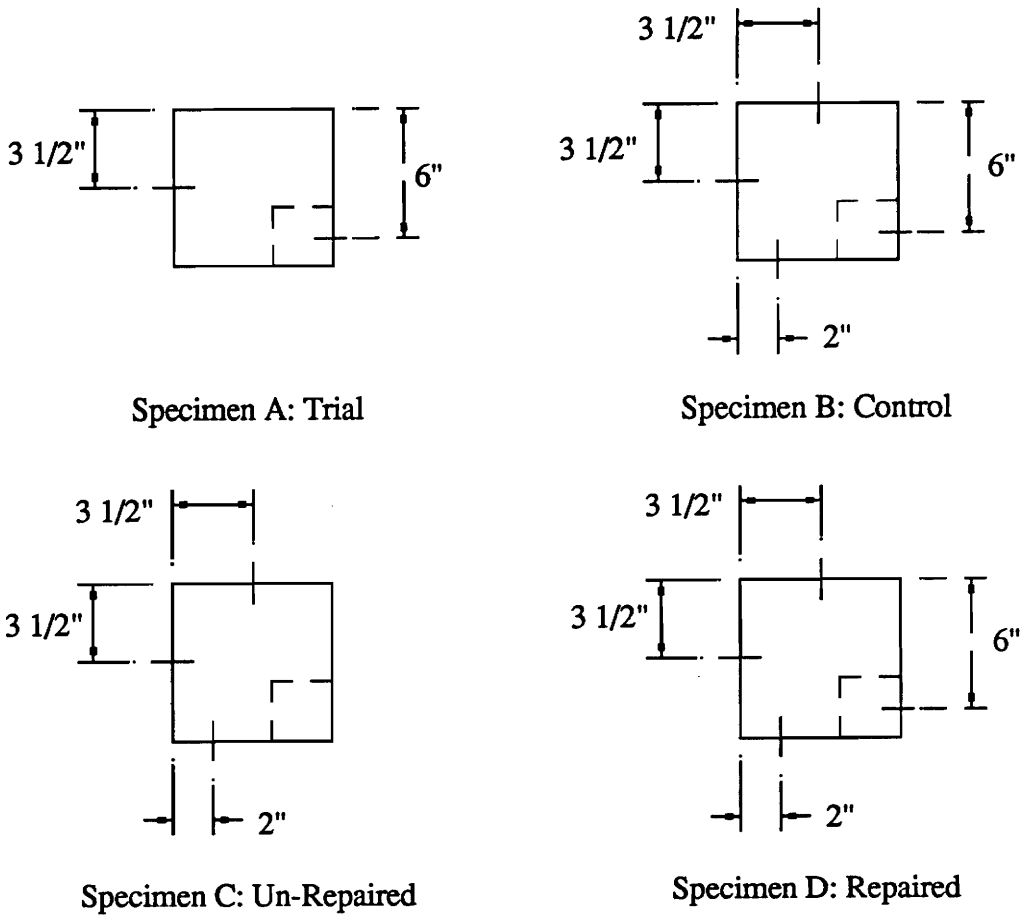

Figure 2-2 Strain Gage Locations

CHAPTER III

EXPERIMENTAL PROGRAM

3.1 General

This chapter discusses aspects of the experimental program. This includes a discussion of the testing apparatus along with the data acquisition methods. The testing procedures are also discussed.

Three types of tests were performed. Two of the tests were used to determine the material properties of the specimen. They were a coupon test and a cylinder test. The coupon test was used to determine the tensile properties of the main reinforcement while the cylinder test was used to determine the compressive strength of the concrete. The third test performed was the actual loading of the specimen.

3.2 Testing Apparatus

All tests, except the cylinder tests, were performed using a computer controlled universal testing machine located in the structures lab. The universal testing machine has a maximum load capacity of 300 kips. Tests performed included static axial loading of the specimens along with coupon testing of the longitudinal reinforcement to determine the stress-strain characteristics.

When the coupon tests were performed, the universal testing machine was setup for a tensile test. "Jaws" were placed in the moving head, and in the stationary head. A 2.5 in. middle portion of the rebar was milled to a smaller diameter to localize the failure. A 2 in. extensometer was connected to the rebar in the milled section to measure strain.

The specimen was then placed in the jaws of the testing machine. A linearly increasing tensile load was applied to the specimen until failure. A stress-strain curve was developed from the acquired data (see Fig. A-1).

During the casting of the specimens, concrete cylinders were made according to ASTM standards. Cylinders were cured for 28 days then placed in the cylinder testing machine. During the cylinder testing, a compressive axial load was applied without shock and at a constant rate of 20 to 50 psi/sec. until failure (ASTM A 39). The 28 day compressive strength was computed by dividing the failure load by the cylinder area.

When the reinforced concrete columns were tested, the universal testing machine was setup to perform a compressive test. The stationary head was outfitted with a pivoting head. This aided in applying a concentric load to the specimen. Steel plates and elastomeric bearing pads or capping material was used for equipment protection and to ensure the load was applied to a flat surface.

3.3 Data Acquisition

In the coupon test, data was obtained by the universal testing machine's software. Axial load and strain was recorded by a computer and was plotted during the test to monitor the progress. When testing concrete cylinders, the failure load of the specimen was recorded by the cylinder testing machine.

During the specimen tests, the universal testing machine's system recorded axial load vs. head displacement, which was also plotted during the test. This indicated the stiffness of the system and most importantly, it gave warning of impending failure. Concrete strain gages instrumented to the specimen were connected to a strain indicator. Loading was paused at prescribed points and strain was manually recorded. To monitor

concrete strain progress, the data was manually entered in a separate computer and plotted. This plot also warns of impending failure along with indicating any load eccentricity on the specimen. Closer inspection of the concrete strain plots indicated the behavior of the specimen, in particular it was desirable to know how the repaired section was behaving compared to the rest of the specimen.

3.4 Testing procedures

For the compressive test, the specimen was placed in the universal testing machine. It was required that the specimen be plumb to ensure a concentric load was applied. On the top and bottom of the specimen, either a elastomeric bearing pad or a capping material was used to ensure a flat surface for which the load would be applied. It was observed that the capping material is better suited for this application. Between the capping material and the load applicator was a 1.5 in. thick steel plate. A plate was used at the top and bottom of the specimen to protect the testing equipment (see Fig. 3-1). Protective shielding was placed around the testing equipment to protect the operator along with the equipment.

The universal testing machine's system requires a specified loading procedure that cannot be altered once invoked. This procedure involved specifying loading rates for up to six "command zones". A command zone may be described as a time frame where a loading procedure was followed. In general, it was recommended that a specimen be loaded relatively quickly at the beginning. Once there was significant load, the loading rate should decrease. For each command zone, a loading rate must be specified. Though the testing procedure may not be altered, it was possible to enter the next command zone if necessary. It was essential to have some idea of what the specimen response may be in

order to program the testing procedure. For the compressive tests in this study four command zones were utilized. Section A.2 in the Appendix describes the command procedures used for the testing of each specimen.

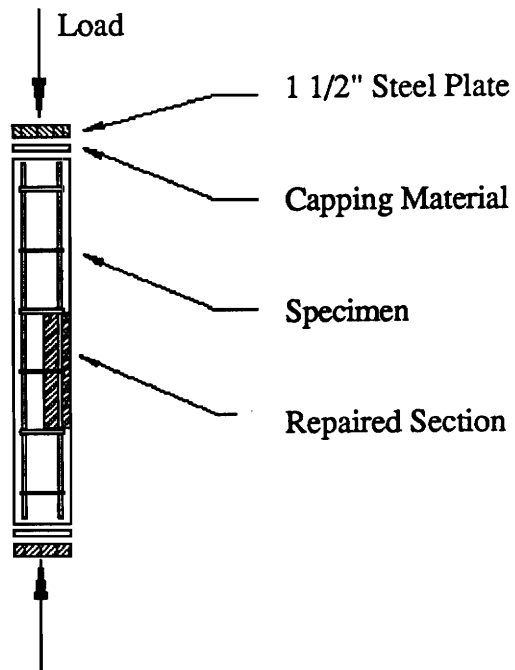

Figure 3-1 Test Setup

CHAPTER IV

RESULTS AND DISCUSSION

4.1 General

This chapter reports results from all tests performed. The material properties are first reported and are summarized by a table. The results of the testing of each specimen are then reported. A comparison of the test results are made in the summary.

4.2 Material Properties

Tensile tests were performed on the No. 4, Grade 60 rebar to determine the actual material properties of the primary reinforcement. As expected, there was a linear relationship between stress and strain until material yielding. The material then reached a plateau where the strain increased with little or no increase in stress. This was followed by a strain hardening region. Data acquisition was discontinued when strain reached 0.05 in./in. to protect the instrumentation. A stress - strain plot for the primary reinforcement is available in Section A.3 of the Appendix.

For the purpose of analysis, it was required to obtain the yield stress of all rebar. Typically, Grade 40, 60 and 80 steels have well defined yield points, however, some of these lack obvious yield plateaus. In this case, the yield stress was recorded at a specified value of strain. This is called the "strain-under-load" method. For Grade 80 and below, an appropriate value of strain is 0.005 in./in. of gage length (ASTM A 370). Some researchers recommend that for Grade 40 and 60 reinforcement, this strain value is 0.005 in./in., and for Grade 80, the value is 0.0035 in./in. (Nawy, 1990). Data from the tensile

tests of the primary reinforcement indicated an obvious yield plateau for specimens A and C (see Fig. A-1). The yield stress was found to be 70 ksi. For specimens B and D, there was not a well defined yield plateau. The yield stress corresponding to a strain of 0.005 in./in. was found to be 80 ksi. Table 4-1 summarizes these values.

Data obtained from the cylinder tests indicated the compressive strength of the concrete was significantly higher than what was used in the design. The values for specimens A and C were found to be 5.5 ksi and for specimens B and D, f'_c was 4.1 ksi.

The void or simulated deterioration, was created using two 2 x 4 wood blocks nailed back to back built into the form at just below mid height. The dimensions of the void was 3 in. x 3.5 in. x 15.5 in. The patching material used was a general purpose ready to use packaged concrete mix. This mix contained a maximum aggregate size of 3/8 in. and was specified to have a compressive strength of 3.5 ksi. Two cylinder tests were performed on this material and an average was taken to identify the actual 28-day compressive strength (see Table 4-1).

Table 4-1 and 4-2 summarize the material properties of each specimen and indicate the predicted loading capacities.

Table 4-1 Material Properties

Specimen	Design f'_c	Substrate f'_c	Repair f'_c	Design f_y	Actual f_y
A: Trial	3 ksi	5.5 ksi	2.6 ksi	60 ksi	70 ksi
B: Control	3 ksi	4.1 ksi	-----	60 ksi	80 ksi
C: Un-repaired	3 ksi	5.5 ksi	Un-repaired	60 ksi	70 ksi
D: Repaired	3 ksi	4.1 ksi	4.6 ksi	60 ksi	80 ksi

Table 4-1 indicates the actual material properties compared to the properties used in design. Although the material strengths were significantly higher, the overall specimen

strength fell within loading limitations. The higher material strength was anticipated and allowed for in the design process. Table 4-2 gives a comparison of the design strength and the new predicted strength. The design strength was computed by Eq. 2-1 and was based on assumed material strengths. The predicted strength was computed using actual material strengths and was based on the following equation

$$P_o = 0.85 \times \sum (f'_c \times (A_{net} - A_{st})) + f_y \times \sum A_{st} \quad (4-1)$$

Equation 4-1 was based on the strength of a truly concentric axial loaded column except modifications were made to account for the repaired material. The equation assumes no load eccentricity and the full strength of the repair.

Table 4-2 Specimen Strength

Specimen	Design Strength *	Predicted Strength **
A: Trial	229 kips	290 kips
B: Control	229 kips	255 kips
C: Un-repaired	229 kips	267 kips
D: Repaired	229 kips	260 kips

* Equation 2-1 Based on assumed material strength

** Equation 4-1 Based on actual material strength

4.3 Specimen A: Trial

Specimen A was a trial specimen. Its purpose was to work any bugs out of the testing procedures. The setup for this specimen was somewhat different than for specimens B and D. The specimen was placed in the universal testing machine between two elastomeric bearing pads and two steel plates. Elastomeric bearing pads were used to ensure a flat surface in which the load was applied.

Two concrete strain gages were applied to the specimen. One on the repaired void and one on the opposing face. The concrete strain gages were strategically placed to indicate when and how much load was being absorbed into the repair. They also indicated the degree of eccentricity of the load. If this eccentricity was unacceptable the specimen was unloaded and corrected. When the axial load vs. concrete strain became non-linear, failure was imminent.

The failure load of the specimen was found to be 136 kips, significantly lower than expected. Little warning was given by the strain gages, however the plot of axial load vs. head displacement indicated a non-linear relationship. It was concluded, failure was occurring at the top of the specimen where load was not significantly increasing while head displacement was. The failure mode was crushing of the specimen where the load was applied.

A visual inspection of the failure revealed that along with the crushing of the top, one face of the specimen developed a vertical crack near the top then sheared off. The sheared piece was primarily concrete cover and it had the dimensions of approximately 1.5 in. x 7.5 in. x 20 in. This was not the desired failure mode, because, along with the repair, the core of the specimen stayed intact. It was not possible to re-test the specimen because a significant amount of reinforcement had been exposed. It was concluded that the elastomeric bearing pads were the cause of the undesired failure so they were eliminated. The test setup was altered for the next three tests so as to prevent this type of failure.

4.4 Specimen B: Control

After the testing of the trial specimen, a plan was developed to test the other specimens. The changes primarily involved the configuration of the test setup along with

the speed of loading the specimen. The bearing pads were replaced by a capping material called Hydrostone. This material is a type of plaster which will reach strengths of up to 10,000 psi when properly cured. Along with the Hydrostone, four angles were welded together to form a square geometry and placed at the top and bottom of each specimen. This created a confining force which aided in keeping the top and bottom together. The setup was successful.

The failure load of specimen B was 286 kips. The specimen displayed a classical unconfined concrete failure. The failure was on a 45 degree angle from the horizontal. Upon observation, there was a broken tie 20 in. from the bottom of the specimen. Also at this point the concrete cover was broken away and the rebar buckled. It is suspected that the failure was initiated by the breaking of the No. 3, Grade 40 tie. This allowed buckling of the main reinforcement, causing spalling of concrete cover, and finally unconfined concrete compression failure in the core of the specimen.

Figure 4-1 is a plot of axial load vs. head displacement. Upon observation, there is a linear relationship between the two almost until failure. One could argue there are three different slopes on this curve. One slope up to 20 kips, a steeper slope to approximately 245 kips and a shallower slope to failure. The first slope may be some initial settlement as the specimen seats itself, while the second slope reflects the actual stiffness of the specimen. The slope of the region just before failure indicates a softening of the specimen prior to the onset of failure.

Figure 4-2 reflects the readings from the concrete strain gages instrumented to the specimen. There are also three regions corresponding to those found in Fig. 4-1. All four gages follow basically the same path. Any difference in readings could be attributed to eccentric loading along with slight errors, +/- 3 %, in the gages.

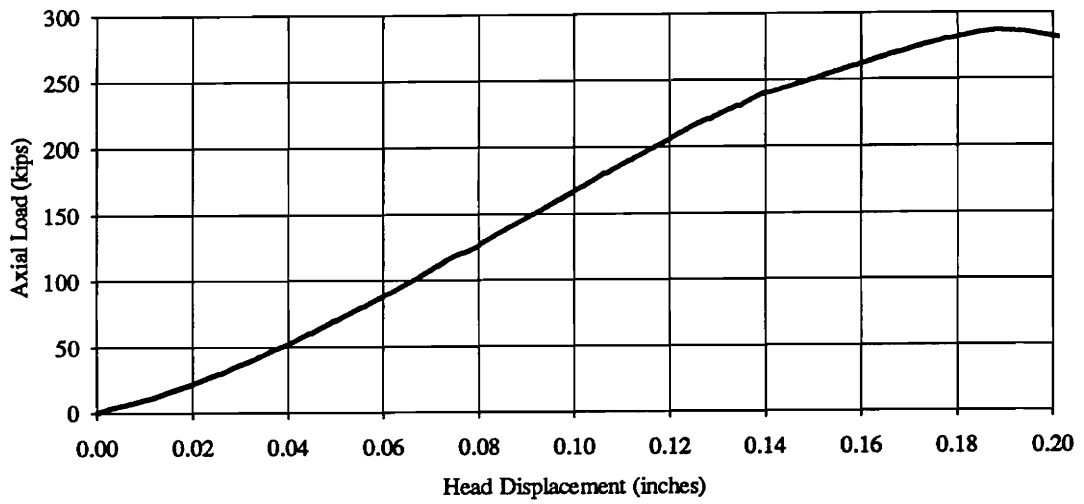

Figure 4-1 Specimen B: Axial Load vs. Head Displacement

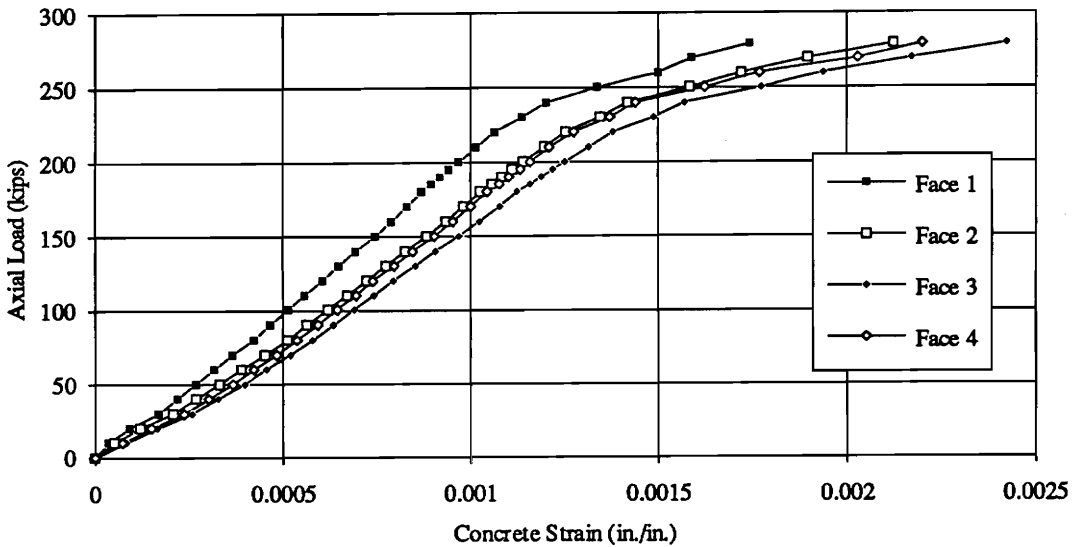
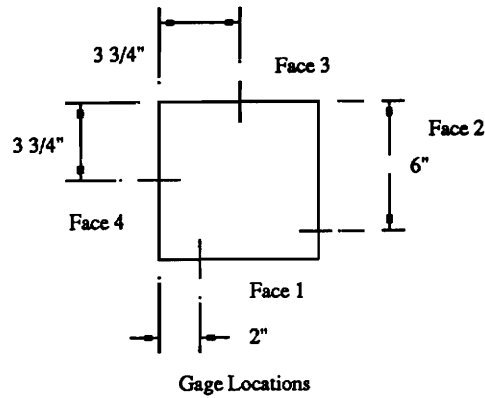

Figure 4-2 Specimen B: Axial Load vs. Concrete Strain

4.5 Specimen C: Un-Repaired

Specimen C was found to have an ultimate load of 265 kips. The failure mode of this specimen was by a compression failure at face 1 and 2. This was no surprise due to the simulated deterioration at faces 1 and 2. When the specimen was loaded there was an eccentricity created by the void. With this eccentricity, a bending effect was created in the

specimen. At the onset of failure, the exposed rebar buckled along with spalling of the concrete cover at the tension side. Along with the loss of concrete, a contributing factor to the reduced failure load was the fact that the exposed rebar was not fully braced as in the case of the other specimens.

In comparing Fig. 4-3 to Fig. 4-1, there was a significant amount of head displacement before failure of this specimen (1.20 in. compared to 0.20 in.). This was due to the bending nature of the failure. This bending nature is exhibited in Fig. 4-4.

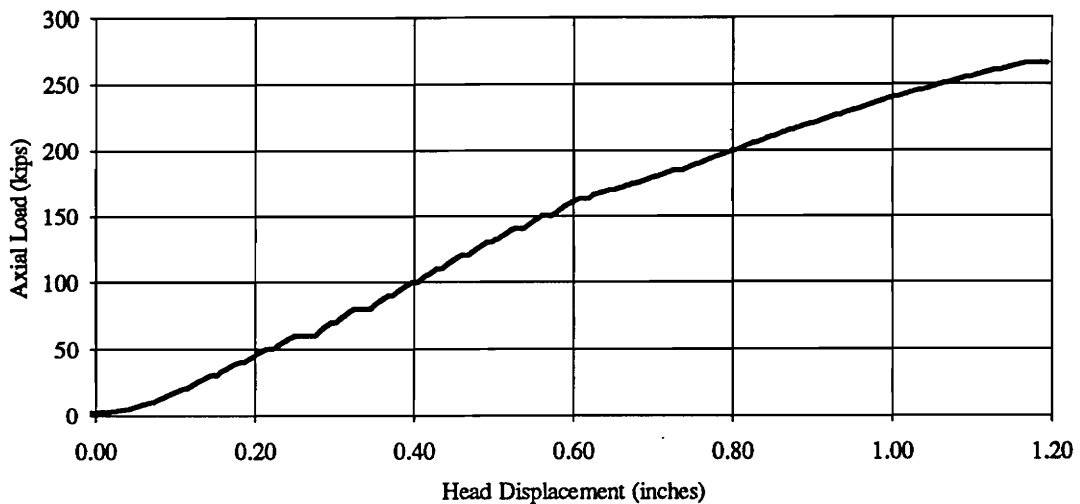

Figure 4-3 Specimen C: Axial Load vs. Head Displacement

Figure 4-4 is a plot of the axial load vs. concrete strain on three of the faces of specimen C. This plot gives good indication of the compression failure at face 1. Just before failure, face 1, closest to the simulated deterioration, was well into the non-linear region, while face 3 and 4 exhibit significantly less compressive strain. At the onset of failure, the strain at faces 3 and 4 began to reduce. Although the readings end before tension in the gages was recorded, face 4 actually displayed significant tension cracks at

the conclusion of the test. The results of the test were not surprising due to the nature of the simulated deterioration.

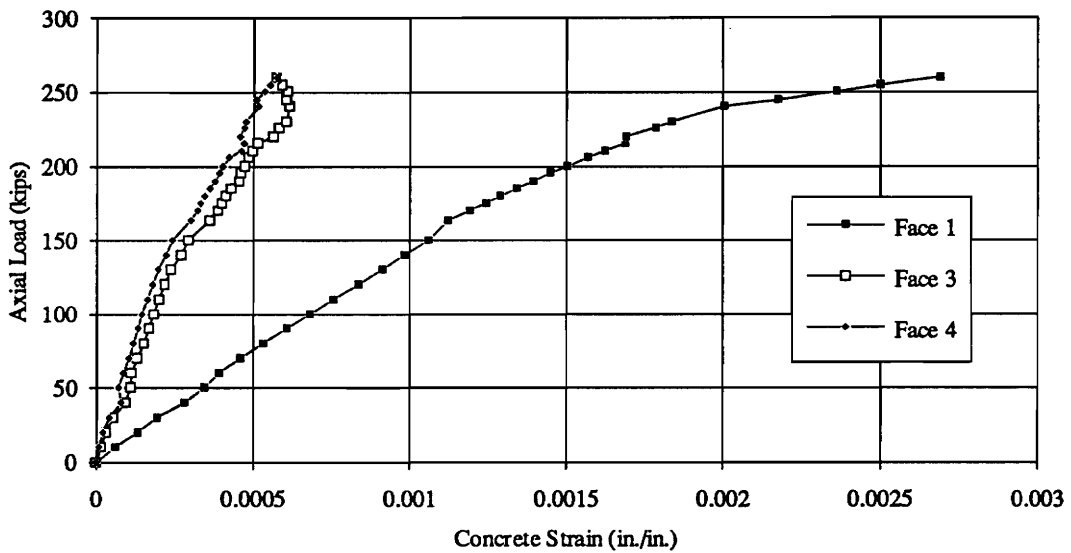
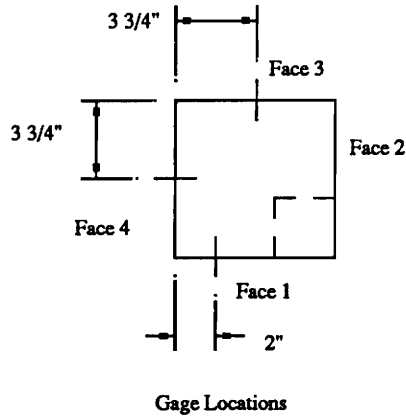

Figure 4-4 Specimen C: Axial Load vs. Concrete Strain

4.6 Specimen D: Repaired

The repaired specimen failed at a load of 293 kips. The failure was localized just above the repaired section. There was buckling of the rebar and unconfined concrete

compression failure at a 45 degree plane. There was no tie failure and the repaired section stayed intact.

Figure 4-5 is a plot of axial load vs. head displacement for specimen D. This curve is very similar to Fig. 4-1, axial load vs. head displacement for specimen B. The two specimens were from the same batch of concrete, thus having the same material properties, i.e. concrete compressive strength and reinforcement tensile strength. When observing Fig. 4-5, there was no indication of repaired simulated deterioration, hence Fig. 4-6 must be referred to in order to study the repaired section.

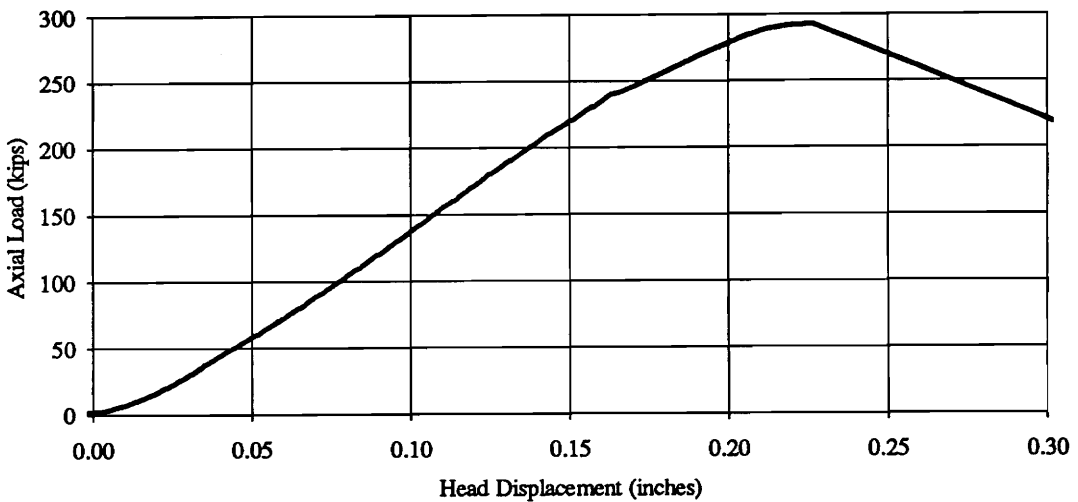

Figure 4-5 Specimen D: Axial Load vs. Head Displacement

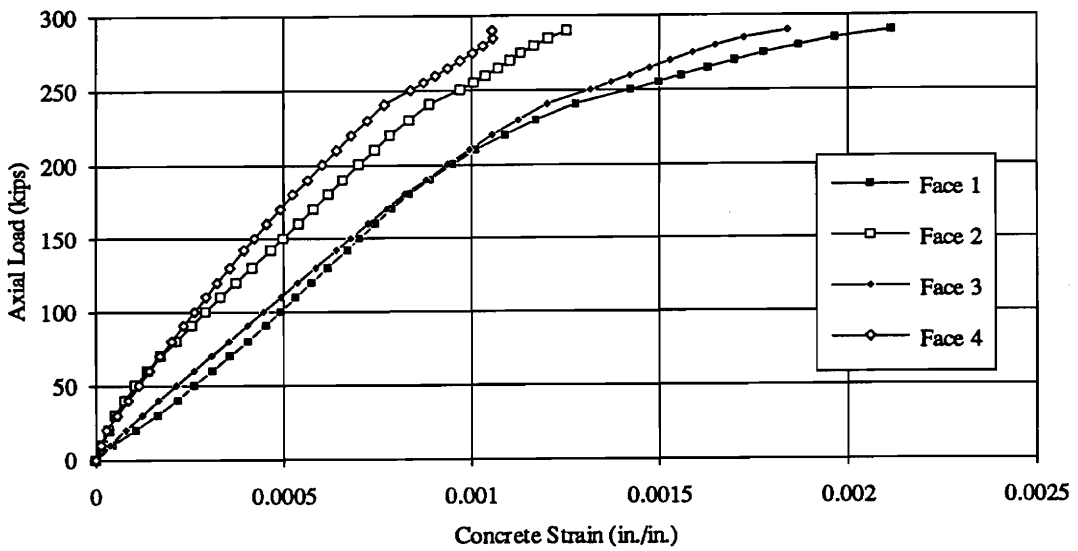
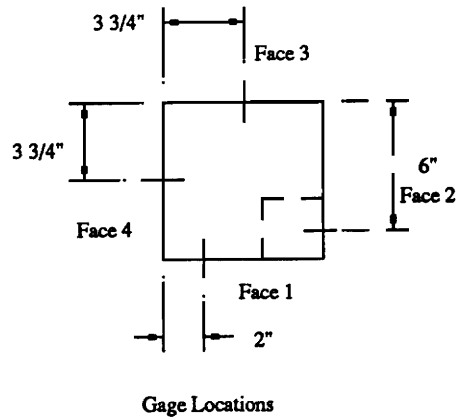

Figure 4-6 Specimen D: Axial Load vs. Concrete Strain

Figure 4-6 is a plot of axial load vs. concrete strain for specimen D. In this plot, the strain in face 2 is of particular interest. This gage was located on the repair of the simulated deterioration.

At the early stages of loading the repaired section contained the lowest amount of compressive strain. As load was increased, the repair picked up more strain and reached a slope comparable to the slopes of the other gages. This indicated shrinkage of the repair. When the repair was cast, it filled the entire void. A hydrostatic head was created to allow

for settlement and to keep pressure on the repair while it cured. As time progressed the repair obtained final dimensions slightly smaller than the void it was filling. The substrate had previously become dimensionally stable, hence its shrinkage ceased. As load was applied, only the substrate compressed until the gap closed between the void and the substrate. As load continued to be applied the repaired section began acting as part of the substrate. At the test conclusion, inspection revealed the bond between the substrate and the repair remained intact.

Because the ultimate load of this specimen was larger than specimen B one could argue the ultimate strength has increased due to a repair with a larger compressive strength than the substrate. Also it could be argued that the increase in ultimate strength could be a result of scattered data. To confirm this, more tests are required.

4.7 Summary

In comparing the tests it is most pertinent to compare the testing of specimens B and D. The results of specimen A do not give much insight with the premature failure. While the results of specimen C did not provide any new information, they did give the expected confirmation that there was significant ultimate strength reduction due to the cross-sectional loss of 19.7 %.

Figure 4-7 is a plot of axial load vs. head displacement for specimens B and C. Because the two specimens had the same material properties, with the exception of the repaired section of specimen D, it was not necessary to normalize this plot. At the initial loading stages both specimens displayed the same softness. This may be due to some settlement as loading begins. Specimen B had a slightly stiffer curve as loading continued, however the ultimate strength was slightly lower than specimen D. For exact values, refer

to Table 4-3. From this observation it could be argued that the repair does not restore the stiffness of the specimen but it does restore the ultimate strength.

Table 4-3 Strength Comparison

Specimen	Predicted Load*	Experimental Ultimate Load
A: Trial	290 kips	136 kips
B: Control	255 kips	286 kips
C: Un-repaired	267 kips	265 kips
D: Repaired	260 kips	293 kips

* Equation 4-1

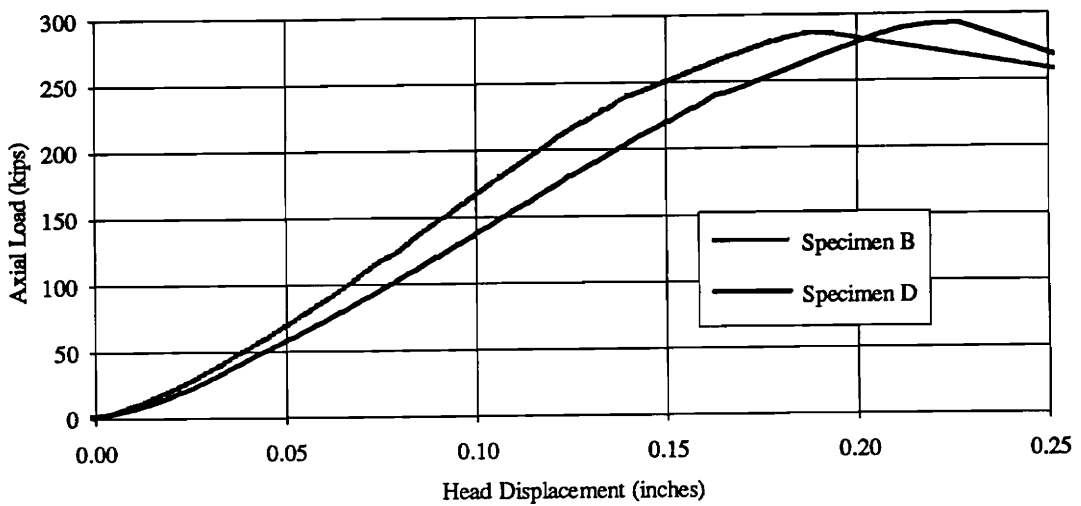

Figure 4-7 Axial Load vs. Head Displacement (Specimens B and D)

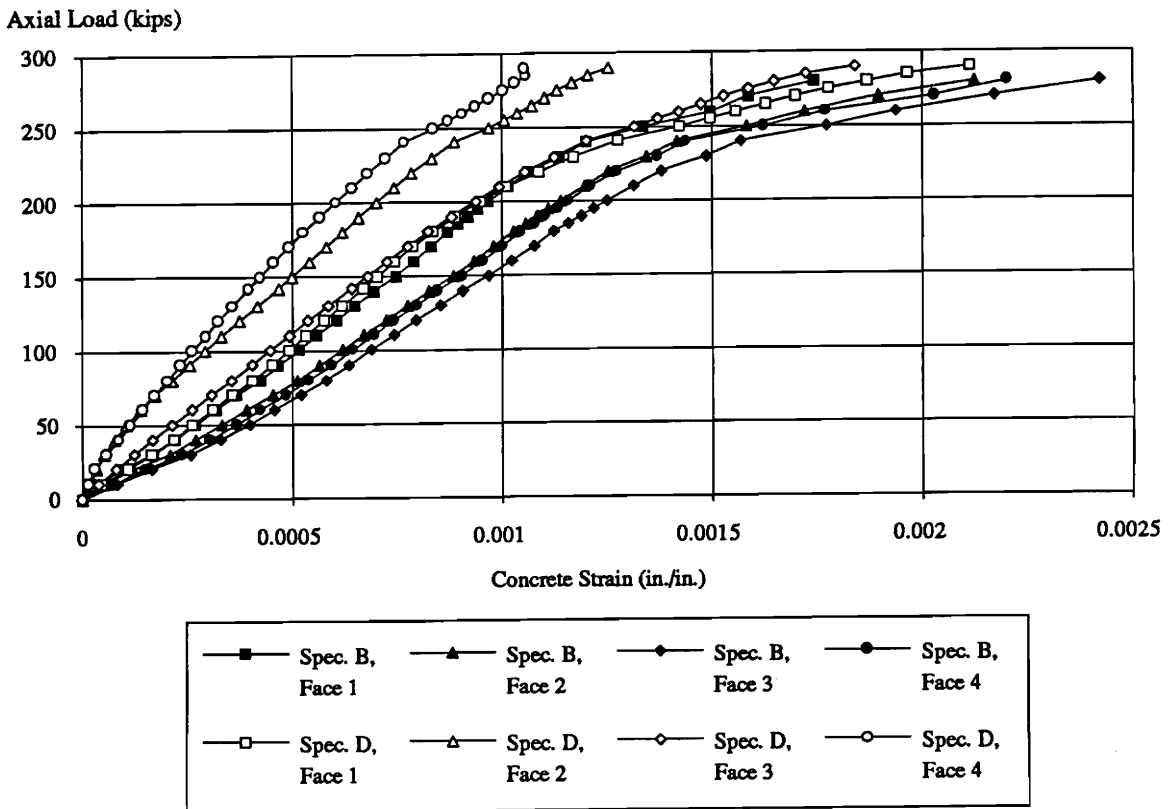

Figure 4-8 Axial Load vs. Concrete Strain (All Specimens)

Figure 4-8 is a comparison of the concrete strains in specimens B and D. This figure indicates, in general specimen B was able to obtain higher values of strain. To study the strain in the section of the repair refer to Fig. 4-9.

The section in question is compared in Fig. 4-9 for the two specimens. The repair of specimen D was shown to have a significantly stiffer slope at the beginning of the loading. This was from the closing of the gap between the substrate and the repair, as discussed in Section 4.6. The slope of the curve then softened but was still slightly stiffer than specimen B. This was likely the result of a stiffer repair material than the substrate. In referring to Table 4-1 previously, f'_c for the repair was 4.6 ksi and 4.1 ksi for the substrate. The modulus of elasticity may be calculated using the equation

$E = 57,000 \times \sqrt{f'_c}$, where E was directly related to the stiffness of the specimen (AASHTO, 1992). In the final loading stages, specimen B exhibits more of a ductile failure. This was indicated by the longer non-linear portion of the plot. It has been concluded this was due to scatter in the data because the failure in the repaired specimen localized above the repair in the substrate.

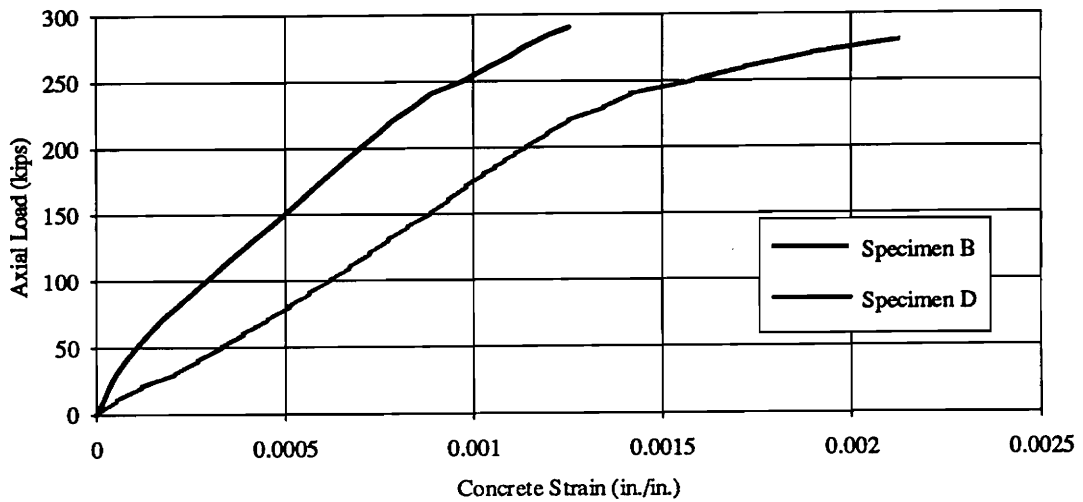

Figure 4-9 Axial Load vs. Concrete Strain (Specimens B and D)

CHAPTER V

CONCLUSIONS AND RECOMMENDATIONS

5.1 General

Conclusions of the pilot study are presented and discussed in this chapter. With the few tests performed it is recognized most conclusions may require further investigation. Following the conclusions are recommendations for further study.

5.2 Conclusions

This study focused on the effects of repairing reinforced concrete bridge columns. The method of repair used, as discussed earlier, was cast-in-place ready-mix concrete. Four test specimens have been designed, fabricated and loaded to failure. The primary purpose was to determine behavioral characteristics along with the effects on ultimate load.

Ultimate load values, obtained from specimens B and D, found in Table 4-3 are reiterated in Table 5-1. These two specimens contained the same material properties with the exception that specimen D contained a repair of simulated deterioration.

Table 5-1 Strength Comparison

Specimen	Ultimate Load
B: Control	286 kips
D: Repaired	293 kips

Table 5-1 indicates that the ultimate strength of the repaired specimen was fully restored. It could be argued that because the repair material had a higher compressive strength than the substrate, the ultimate strength had slightly increased. It could also be argued that the control specimen failed prematurely due to a tie failure, thus raising suspicion of the ultimate load value.

Although the ultimate strength was restored, the stiffness of the specimen was not. This was indicated previously in Fig. 4-7, axial load vs. head displacement of specimens B and D. This may be due to shrinkage of the repair material within the void along with slippage along the interface between the repair and the substrate.

5.2 Recommendations

It is recommended that further study be performed to verify the restoration of ultimate strength of repaired specimens. Other parameters should be included in the study to broaden the sampling of data. Such parameters may include the use or lack of various bonding agents when studying the interaction of the repair and the substrate. A circular cross-section with spiral reinforcement should be considered because many highway bridge columns are of this geometry. Various repair material with a wide range of compressive strengths should be considered. Light weight concrete may present interesting results. Various deterioration configurations should also be considered along with various methods of repairing the specimen. Due to a possible premature failure of the control specimen, closer spacing of the ties should be investigated.

REFERENCES

- AASHTO (1992). *Standard Specifications for Highway Bridges*, 15th Edition, American Association of State Highway and Transportation Officials, Washington D.C.
- ASTM C 39 (1986). "Test Method for Compressive Strength of Cylindrical Concrete Specimens," *ASTM Book of Standards*, Part 04.02, ASTM, Philadelphia, pp 20-24.
- ASTM A 370 (1992). "Standard Test Methods and Definitions for Mechanical Testing of Steel Products," *ASTM Book of Standards*, Part 01.03, ASTM, Philadelphia, pp 98.
- Cleland, D. J. (1993). "In-situ Methods for Assessing the Quality of Concrete Repairs," *Proc. Instn Civ. Engrs Structs & Bldgs*, v. 99, no. 1, pp 68-70.
- Karbhari, V. M., Eckel, D. A. (1993). "Strengthening of Concrete Column Stubs through Resin Infused Composite Wraps," *J. Thermoplastic Composite Materials*, v. 6, no. 2, pp 92-107.
- Nagaraja, M., Sinha, S., Sabnis, G. M. (1993). "Concrete in New York Transit Structures (From 1910 to Present)," *Concrete International*, v. 15, no. 2, pp 50-53.
- Nawy, E. G. (1990). *Reinforced Concrete: A Fundamental Approach*, Prentice Hall, New Jersey.
- Planck, S. M., Klaiber, F. W., Dunker, K. F. (1993). "Postcompression and Superimposed Trusses for Bridge Rehabilitation," *J. Struct. Engrg.*, ASCE, v. 119, no. 3, pp 978-991.

APPENDIX

A.1 Nomenclature

P_o = Design strength or Predicted strength
 f'_c = 28-day concrete compressive strength
 A_g = Gross area of cross-section
 f_y = Yield stress of rebar
 A_{st} = Area of rebar
 A_{net} = Net concrete cross-sectional area

A.2 Loading Procedures

Command Zone 1:

Feedback for rate	Load
Rate for Command Zone 1	12,000 # per min
Feedback for end level	120,000 #
Maintain Time	30 sec
Gain (P,I,D)	3

Command Zone 2:

Feedback for rate	Load
Rate for Command Zone 2	7,000 # per min
Feedback for end level	180,000 #
Maintain Time	30 sec
Gain (P,I,D)	3

Command Zone 3:

Feedback for rate	Load
Rate for Command Zone 3	4,5000 # per min
Feedback for end level	240,000 #
Maintain Time	30 sec
Gain (P,I,D)	3

Command Zone 4:

Feedback for rate	Load
Rate for Command Zone 4	1,000 # per min
Feedback for end level	300,000 #
Maintain Time	30 sec
Gain (P,I,D)	3

Description of Command Zone parameters;

Feedback for rate - Options (load, speed or stress)

Rate for Command Zone - Rate at which specimen is loaded

Feedback for end level - The end of the command zone

Maintain Time - Amount of time to remain at end level before proceeding

Gain (P,I,D) - Has to do with the gain of the feedback signal. A higher number is more sensitive. If the load or position is found to oscillate about a point, may try reducing the gain.

To summarize the previous table, the specimen was initially loaded at 12,000 pounds per minute until 120,000 pounds was reached, then the loading was paused for thirty seconds. Command zone 2 was entered, and the loading resumes at 7,000 pounds per minute. At 180,000 pounds, the loading was again paused for thirty seconds. Command zone 3 was entered and the loading resumes at 4,500 pounds per minute until 240,000 pounds was reached. Finally command zone 4 was entered and the loading resumes at 1,000 pounds per minute until 300,000 pounds was reached. This was the maximum load of the system and all specimens were expected to fail before this point.

A.3 Reinforcement Data

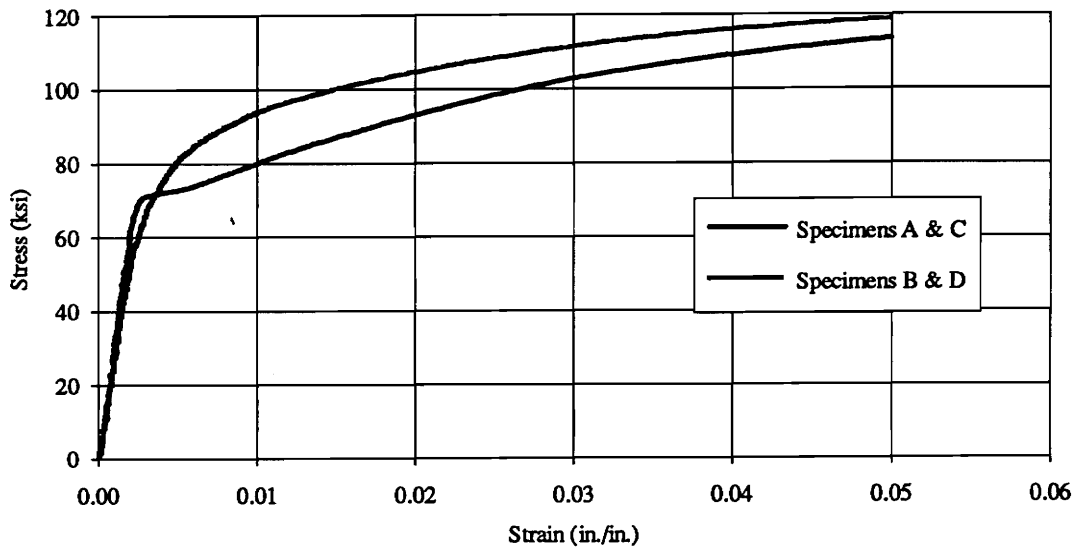

Figure A-1 Stress vs. Strain (Main Reinforcement)

A.4 Sample Calculation

Calculation of P_o (actual values):

$$P_o = 0.85 \times \sum (f'_c \times (A_{net} - A_{st})) + f_y \times \sum A_{st}$$

Where:

P_o = Design strength or Predicted strength

f'_c = 28-day concrete compressive strength

f_y = Yield stress of rebar

A_{st} = Area of rebar

A_{net} = Net concrete cross-sectional area

Specimen D: Material Properties

	Substrate	Repair
f'_c	4.1 ksi	4.6 ksi
f_y	80 ksi	80 ksi
A_{net}	45.75 in ²	10.5 in ²
A_{st}	0.6 in ²	0.2 in ²

$$P_o = 0.85 \times \sum (f'_c \times (A_{net} - A_{st})) + f_y \times \sum A_{st}$$

$$P_o = 0.85 \times (4.06 \times (45.75 - 0.6)) + 4.6 \times (10.5 - 0.2) + 80 \times (0.6 + 0.2)$$

$$P_o = 260.1 \text{ kips}$$

Vita

The author was born July 15, 1968, in Point Pleasant, New Jersey. He graduated from Point Pleasant Beach High School in 1986. In August of 1986 he undertook undergraduate studies at the University of Tennessee at Chattanooga where he studied Engineering and participated in the Wrestling Program. He completed his Engineering degree in December, 1991 and in the Spring, began his graduate studies at Virginia Tech. During his stay at Virginia Tech, he served as the assistant wrestling coach while studying in the Civil Engineering (Structures) Program. His future plans are to continue in the Doctorate program at Virginia Tech and later, to work in industry.

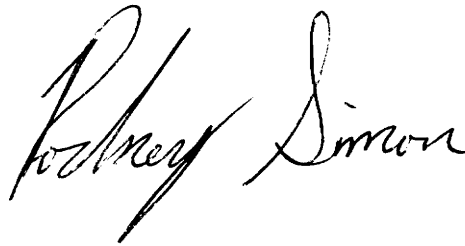
A handwritten signature in cursive script that reads "Rodney Simon". The signature is written in black ink and is centered on the page.