



---

**ARCHITECTURAL POSTURES:**

*a proposed education center of nature for  
rock creek park*

*washington, dc*

*Thesis submitted to the faculty of the  
Virginia Polytechnic Institute and State University  
in partial fulfillment of the requirements for the degree of*

**Master of Architecture**

*Washington-Alexandria Architecture Center  
Alexandria, Virginia*

*June 2004*

*Robert D. Franklin*

---

*Susan Piedmont Palladino, Chair*

*Dr. Paul Emmons*

*Dr. Caren Yglesias*

---

## ABSTRACT

Application of the joints of the bones to mechanics.

*The human form becomes the bearer of my inspiration, revealing a cosmology within itself, appealing to the idea of understanding the body and implementing its essence into architecture. The lessons found in the tectonic of one's body will assist in discovering an integral logic that may translate in the design of the building. Living organisms inspire architectural posture that generate my architectural ideas. Architecture considered, in a very natural way reflects humans. I try to find a methodology inspired by natural organisms, finding the human body the most beautiful and functional of all natural objects. The structure begins to illustrate the innovation of the materials being employed to a different type of solution to a structural problem. The truth of materials, and honesty in the expression of structure reflect the movement of the object.*

Application of the play of muscles and tendons to mechanics.

*"To me, there are two overriding principles to be found in nature which are the most appropriate for building; one is the optimal use of material, the other the capacity of organisms to change shape, grow, and to move."*

Santiago Calatrava

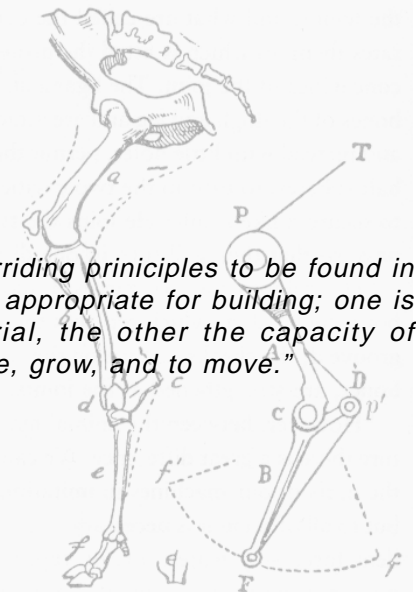

---

## ACKNOWLEDGEMENTS

*I thank my committee for allowing me to explore my ideas and enriching my experience at WAAC. Also, I would like to thank my professors, and especially Jaan for his endless analagous commentary. You will be missed!*

*Many thanks to George, Alejandro, Victor, Kenji, and especially Natalia for assisting at the eleventh hour. I thank everyone else for befriending me, and making me feel at ease. My short but wonderful time at the Center was a memorable one.*

*Most importantly, thanks to my beautiful family and friends who never once doubted my dreams. I love you all.*

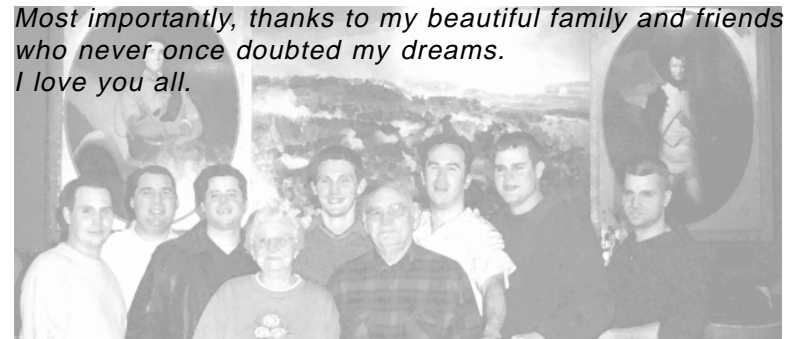

---

*"My principles are devoted to spatial relationships, joining of materials, ambiguity between interior and exterior, and marriage of building to ground."*



*Viollet-le-Duc*

---

## TABLE OF CONTENTS

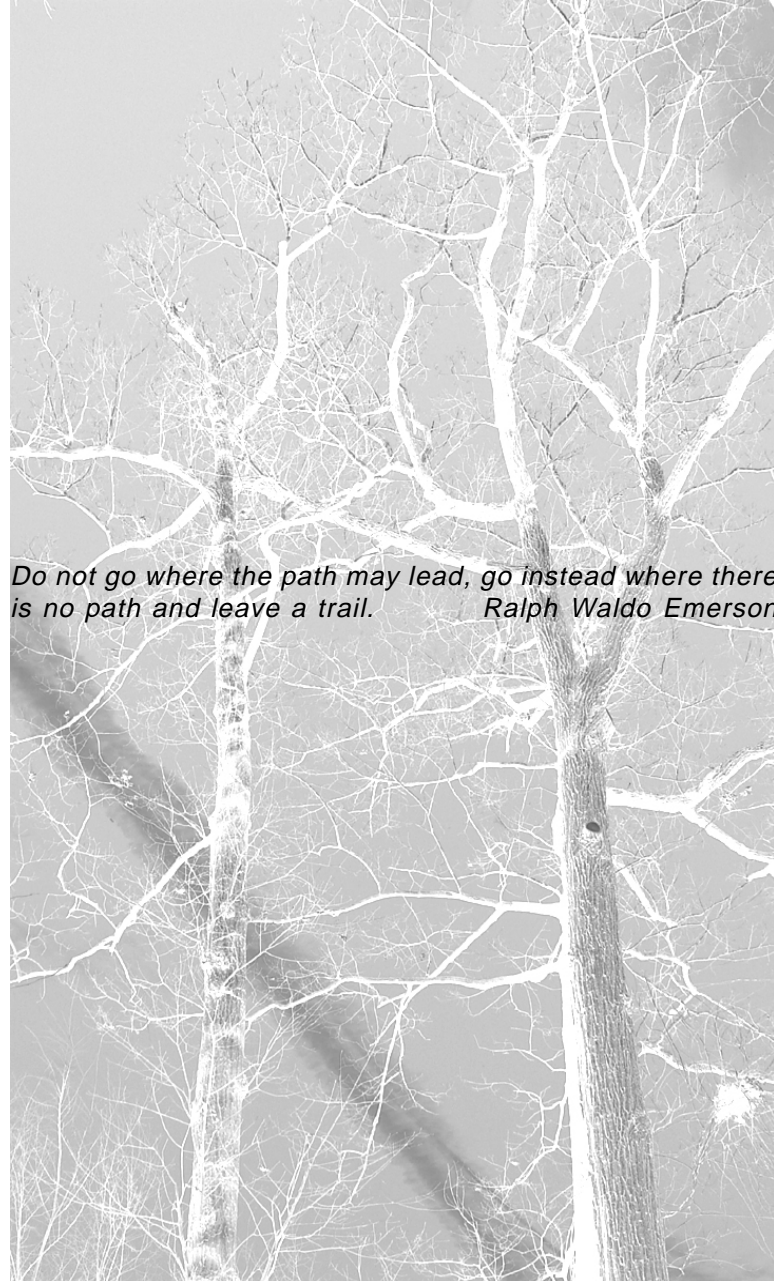

*Do not go where the path may lead, go instead where there is no path and leave a trail.*      *Ralph Waldo Emerson*

<i>introduction</i>	1
<i>site</i>	2
<i>existing site conditions</i>	3
<i>program</i>	5
<i>process</i>	6
<i>design development</i>	9
<i>new site plan</i>	11
<i>floor plans</i>	12
<i>roof plan</i>	15
<i>transverse section a</i>	16
<i>planetarium study</i>	17
<i>transverse section b</i>	18
<i>longitudinal section</i>	19
<i>details</i>	21
<i>elevations</i>	23
<i>sectional model</i>	27
<i>renderings</i>	29
<i>bibliography</i>	30
<i>vita</i>	31

## INTRODUCTION

*The story begins with a hypothetical fire that started one blistery winter day when a few hot embers escaped from the old stone fireplace and caught fire to the existing nature center. Within a few moments, the building was engulfed in flames and all that remained were masonry foundation walls and the old stone fireplace. Many alternate sites were considered, but most sites meant disturbing the soil. The Park Service has very strict regulations that prohibit any further building within Rock Creek Park. Therefore, I sought to reclaim the area where the nature center once stood. There were many reasons why I chose to reuse the site: accessibility of the site for school buses to visit, existing infrastructure, reuse of the existing foundation walls to retain the earth, and the old stone fireplace.*

*The building postures itself between old and new, and has minimal disruption to its surrounding environment. The new structure delicately touches the ground in a concentrated point load along an orthogonal grid slightly skewed from the original. The old stone fireplace will remain exposed and become the point of entry.*

*The new nature center will educate school children and visitors on the wildlife and forestry within Rock Creek Park. The building itself will become a tool for learning, promoting honesty in materials and the expression of structure. The interior space is an open plan for optimal flexibility for setting up exhibitions. The planetarium is positioned at the north end of the building, and its structure is exposed. The building is meant to be a glass pavilion making the visitor fully aware of the forest of trees beyond.*

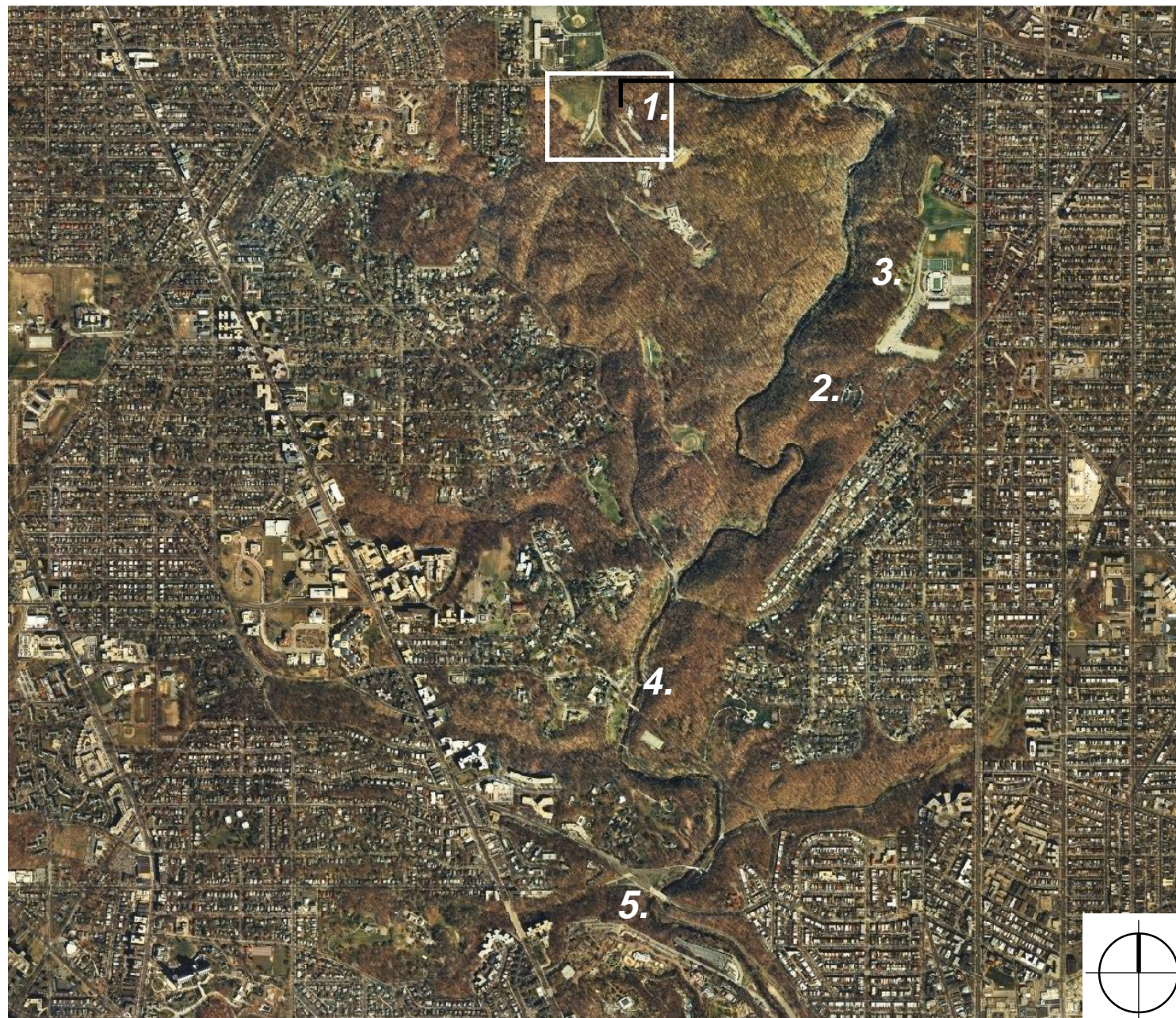

proposed site

*Rock Creek Park is located in northwest Washington, D.C. The park is the oldest and largest naturally managed urban park in the United States. The core of Rock Creek Park is the creek, wildlife, and the forest of trees. The underlying topography is gently rolling hills with a floodplain which becomes more steeply sloped just north of the District line. It's a place where people can reflect and soothe their spirits through the beauty of nature.*

1. *Proposed education center*
2. *Carter Barron Amphitheater*
3. *Tennis Stadium*
4. *Pierce Mill*
5. *National Zoological Park*



## EXISTING SITE CONDITIONS



*The existing site is at one of the highest elevations, and gradually descends into the park. There are several large rock outcrops, a stream that flows into Rock Creek, foot trails that connect back to the park, and mature elm and oak trees that surround the site. All sights and sounds of the city are silenced momentarily by the surrounding oak trees that dance throughout the site. A sense of solitude is reached within the hustling city where we leave our crowded houses and enter the landscape.*

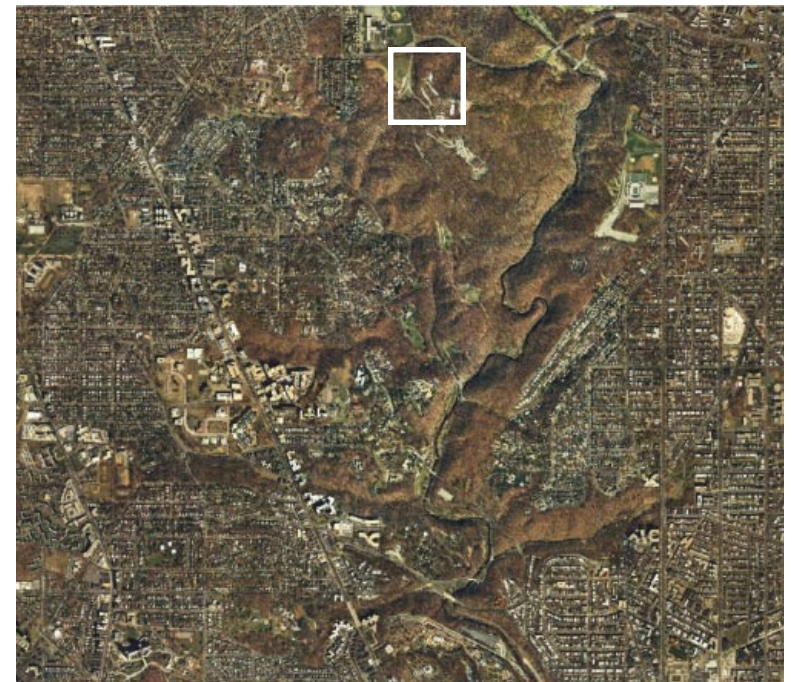



*There are several main spaces within the nature education center:*

**1.live exhibition space**-environmental education programs that demonstrate the park's wildlife and forestry.

**2.tree top mezzanine**-a separate meditation space to contemplate man's interrelationship with nature.

**3.library**-dedicated to the park's natural and cultural history.

**4.planetarium**-visitors can observe the projected night sky as it would appear in Washington, DC.

*The walls are glass to allow the visitors to be aware of their outside surroundings at all times. The south/southwest facing elevations have shading devices that filter the amount of sunlight admitted through the glass. Some of the materials include bamboo flooring, steel connection plates, curtain wall system, copper roofing, salvaged heavy timber, and an existing stone chimney. The building is seen as an extended path into nature with a raised deck among the trees.*

*The simple structure anchors the building to the site and sets the foundation for a simple plan to which unique details add elements of interest.*

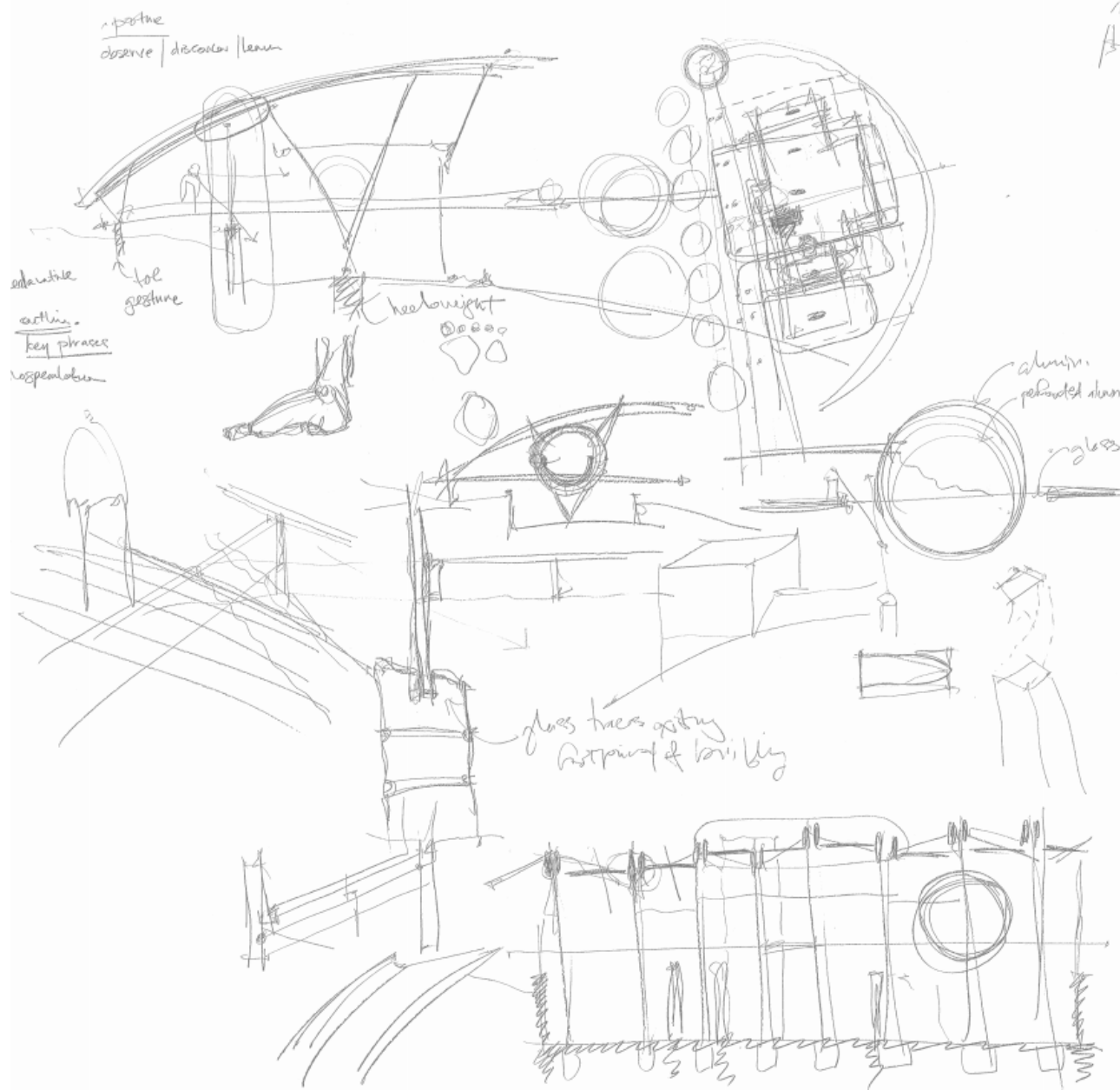
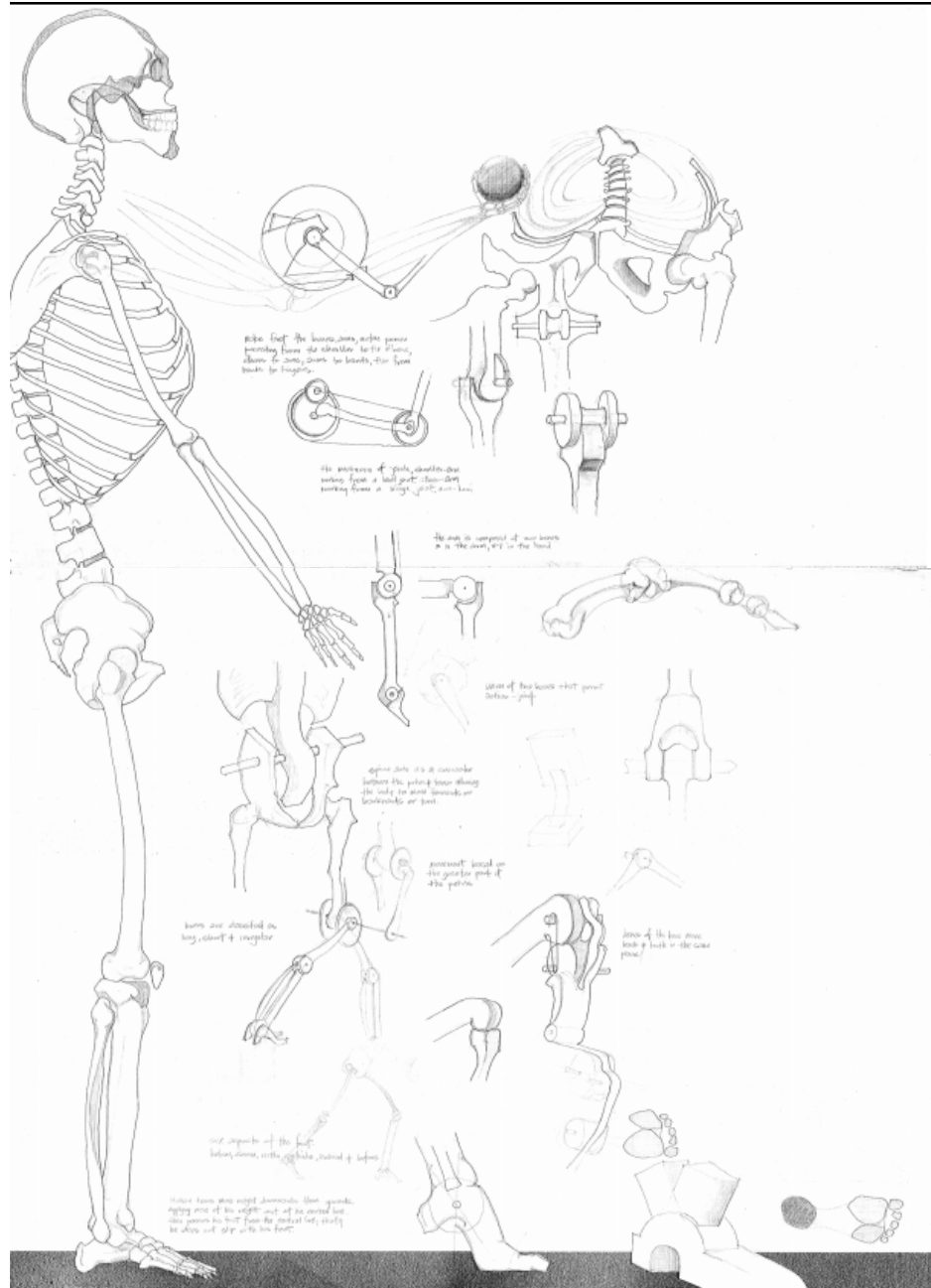

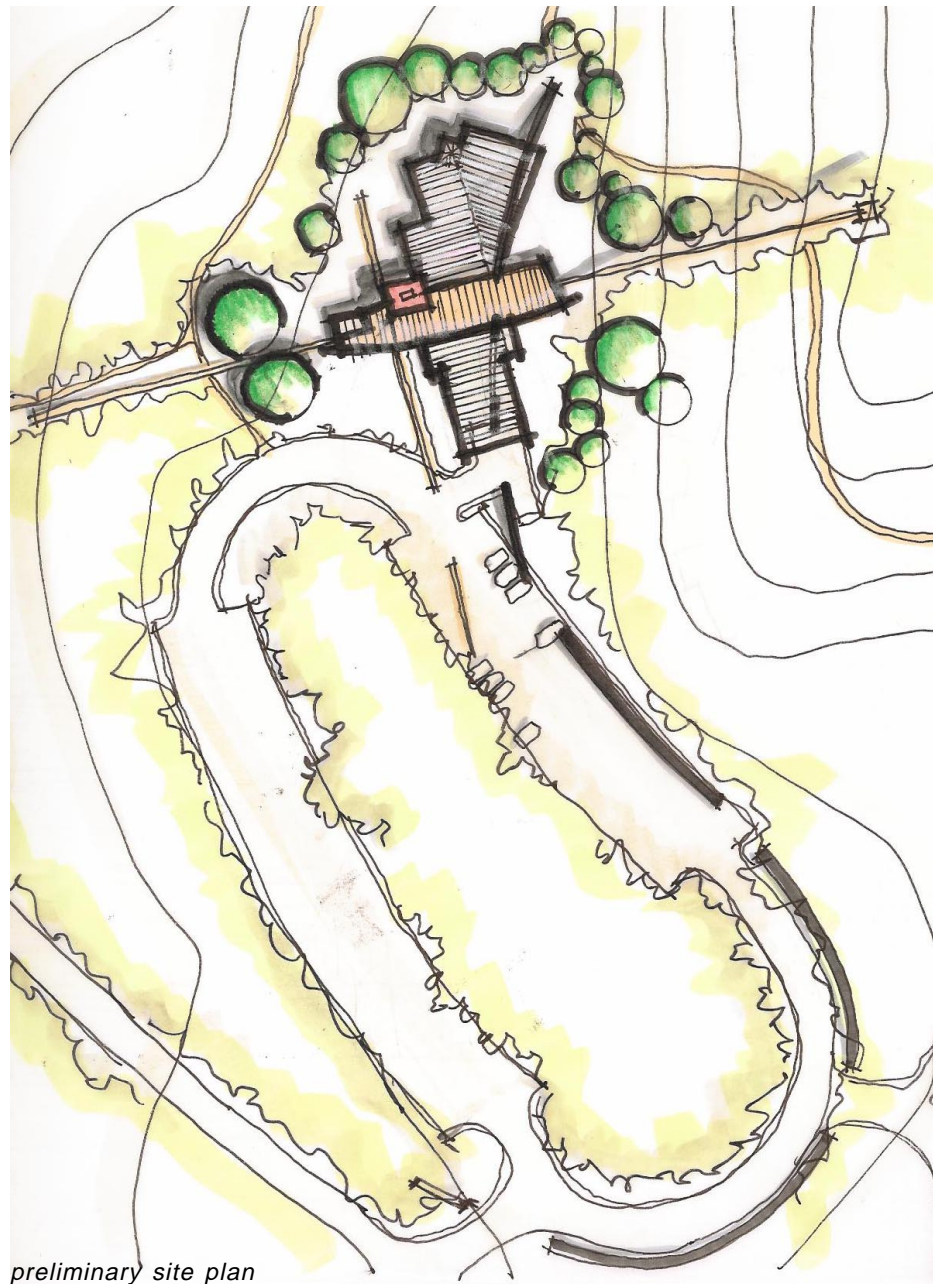

preliminary site plan

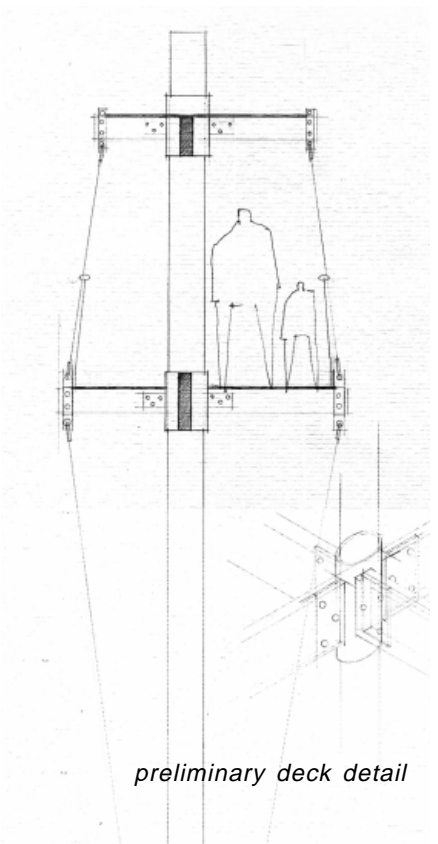

preliminary deck detail

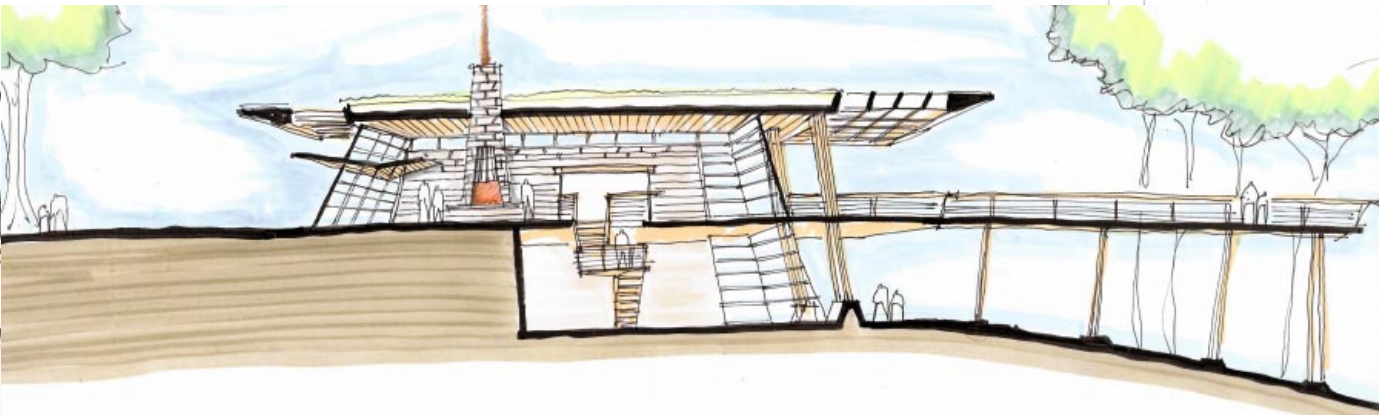

preliminary building section

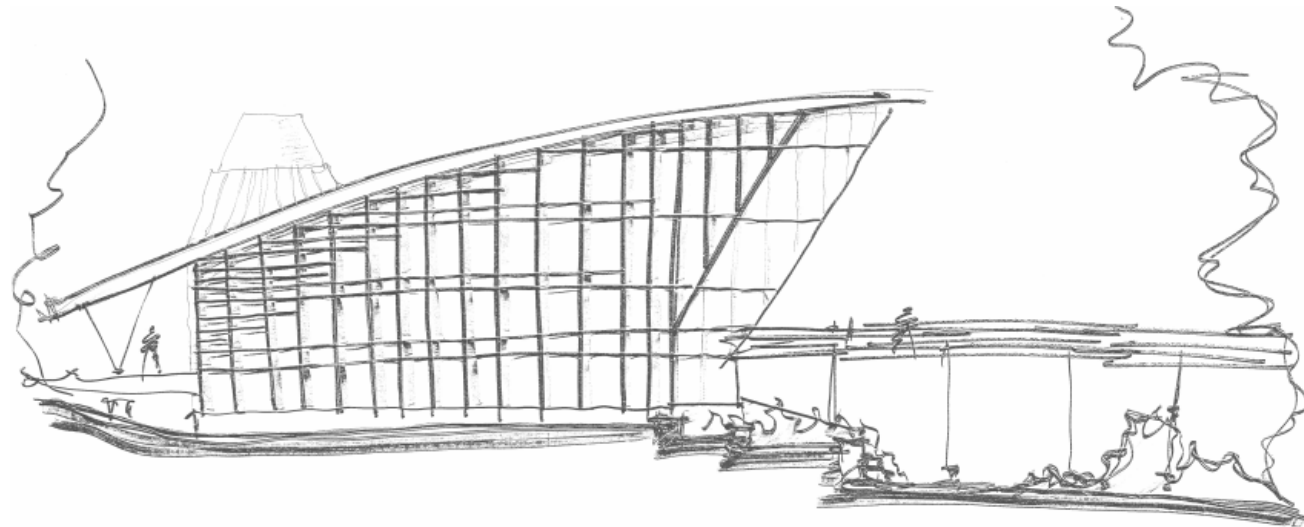

schematic south elevation

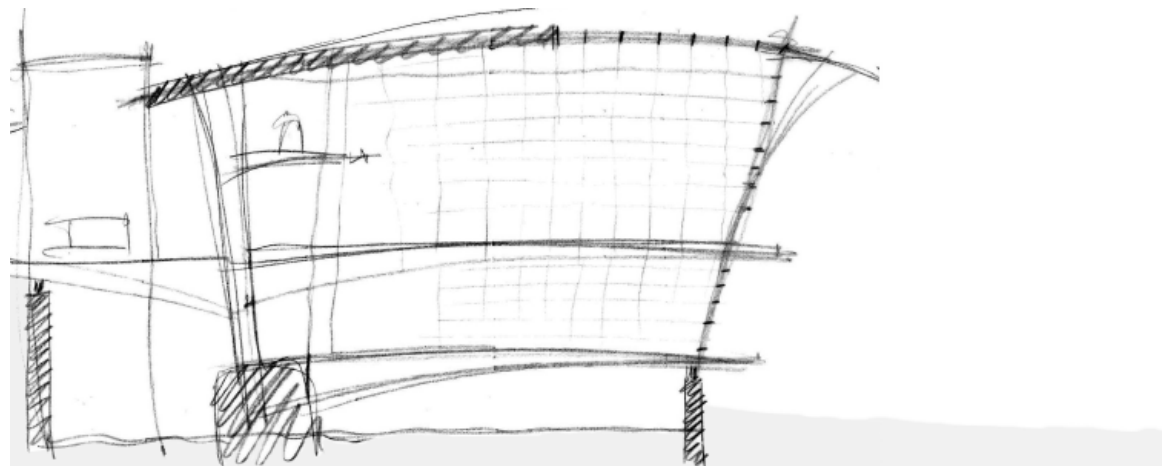

schematic section

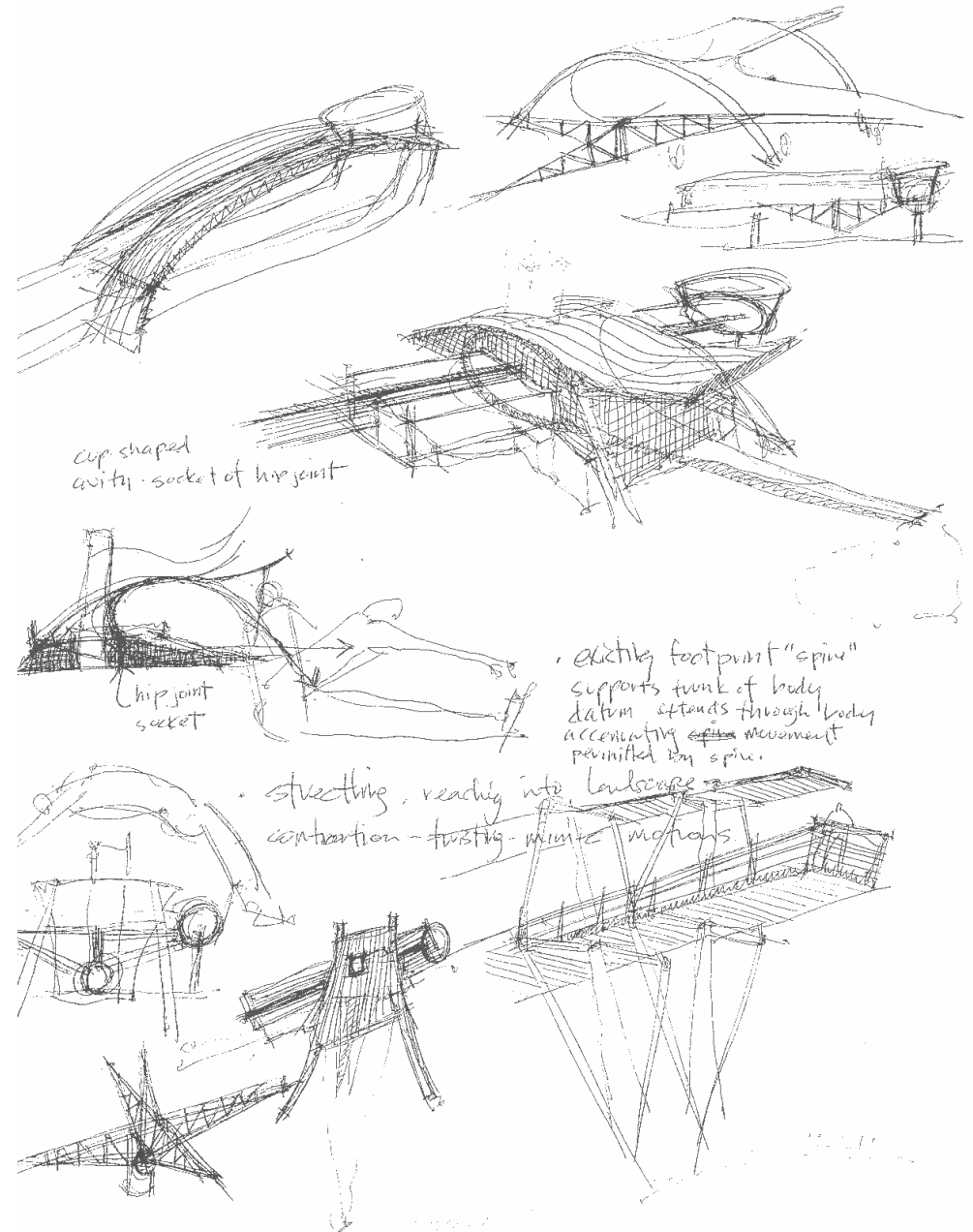

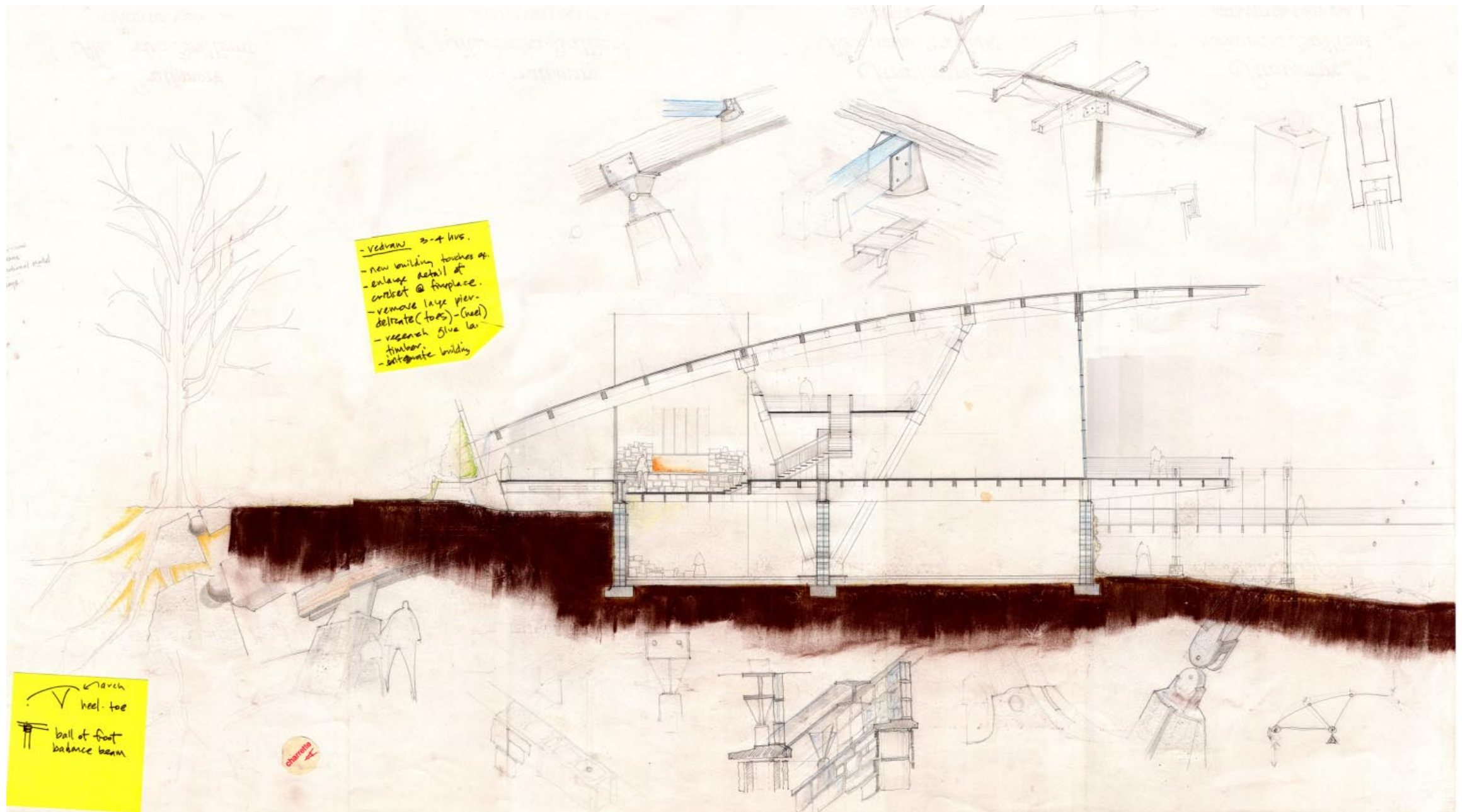

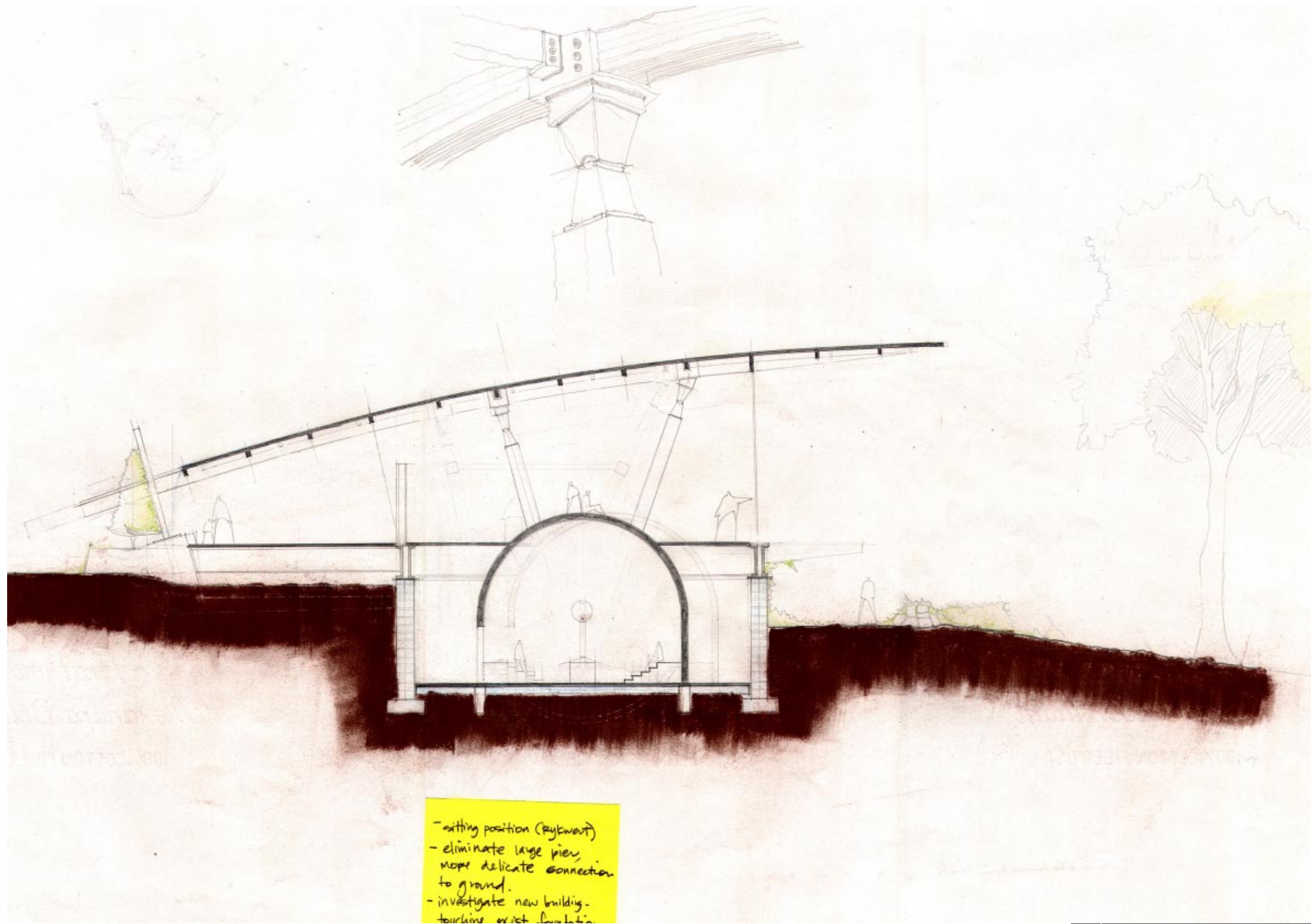

- sitting position (backward)
- eliminate large pier, more delicate connection to ground.
- investigate new building - touching exist foundation

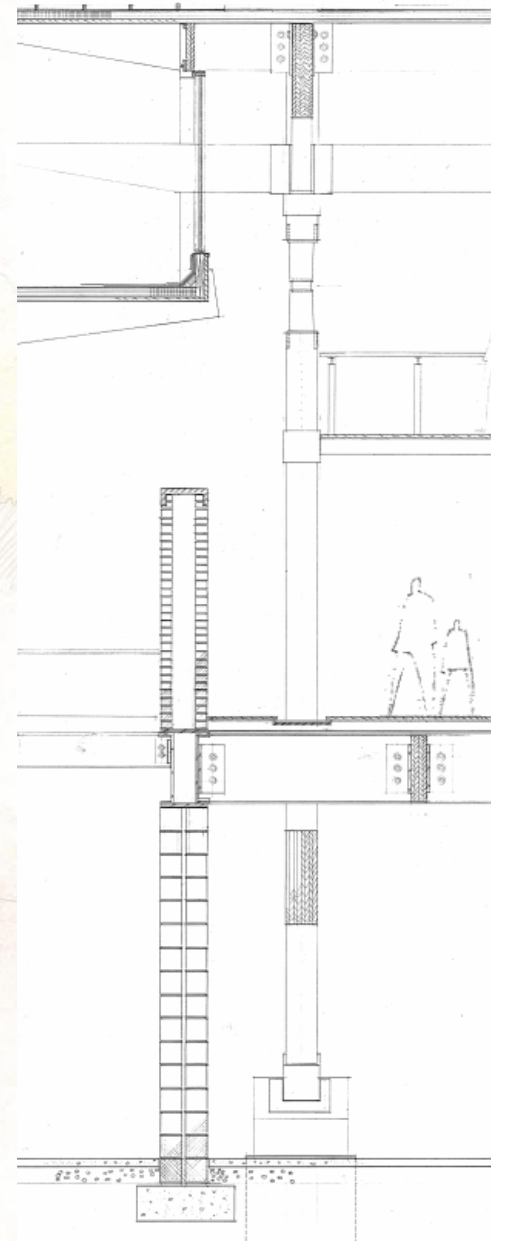

## NEW SITE PLAN



The new site plan utilizes existing infrastructures and postures the nature education center with minimal disruption to the site. A walkway extends to the parking lot from the building welcoming guests as they arrive. The visitor walks towards the building and is able to see through the building to the trees beyond, revealing a layer of transparency. A gutter runs along the western edge of the walkway directing rain water off the roof. Then, the rain water becomes collected, filtered and flows into Rock Creek presenting an educational tool for people to learn about storm water mitigation. There is a reflection pool at the end of the walkway creating a place for meditation. There are a series of terraced outdoor classrooms radiating from the building that identify plants and flowers indigenous to Rock Creek Park. Also, new footpaths are created to connect existing nature trails that meander throughout the park.

## GROUND FLOOR PLAN

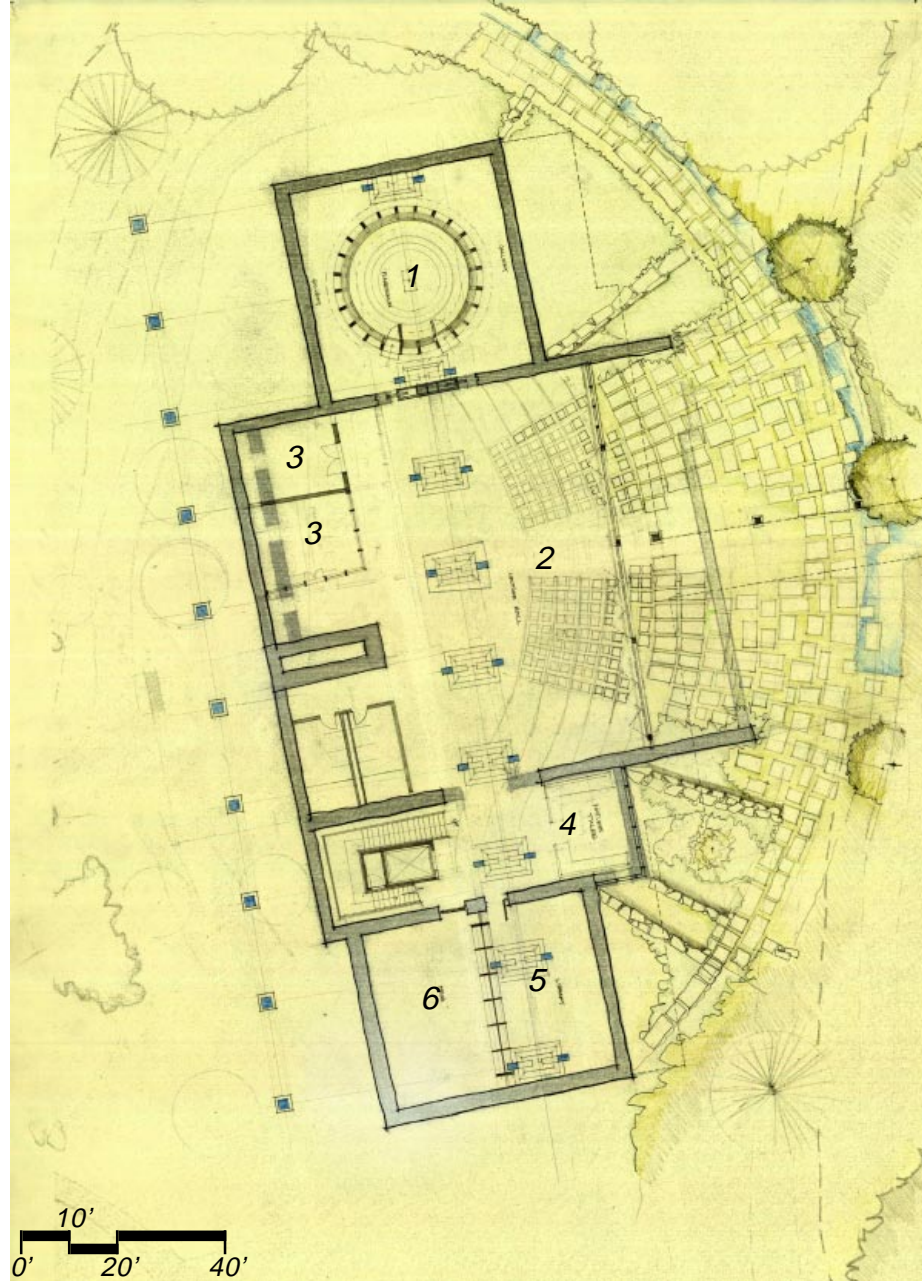

1. planetarium
2. lecture hall
3. classrooms
4. reading area
5. library
6. mechanical room

*the existing foundation walls are represented by thick grey lines*

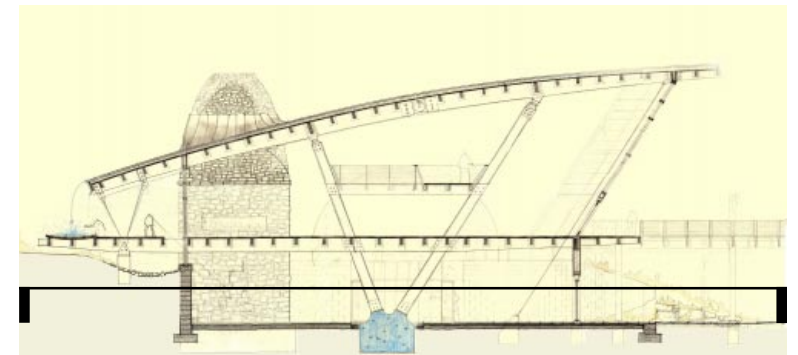
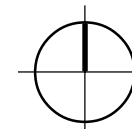

## PRINCIPLE FLOOR PLAN

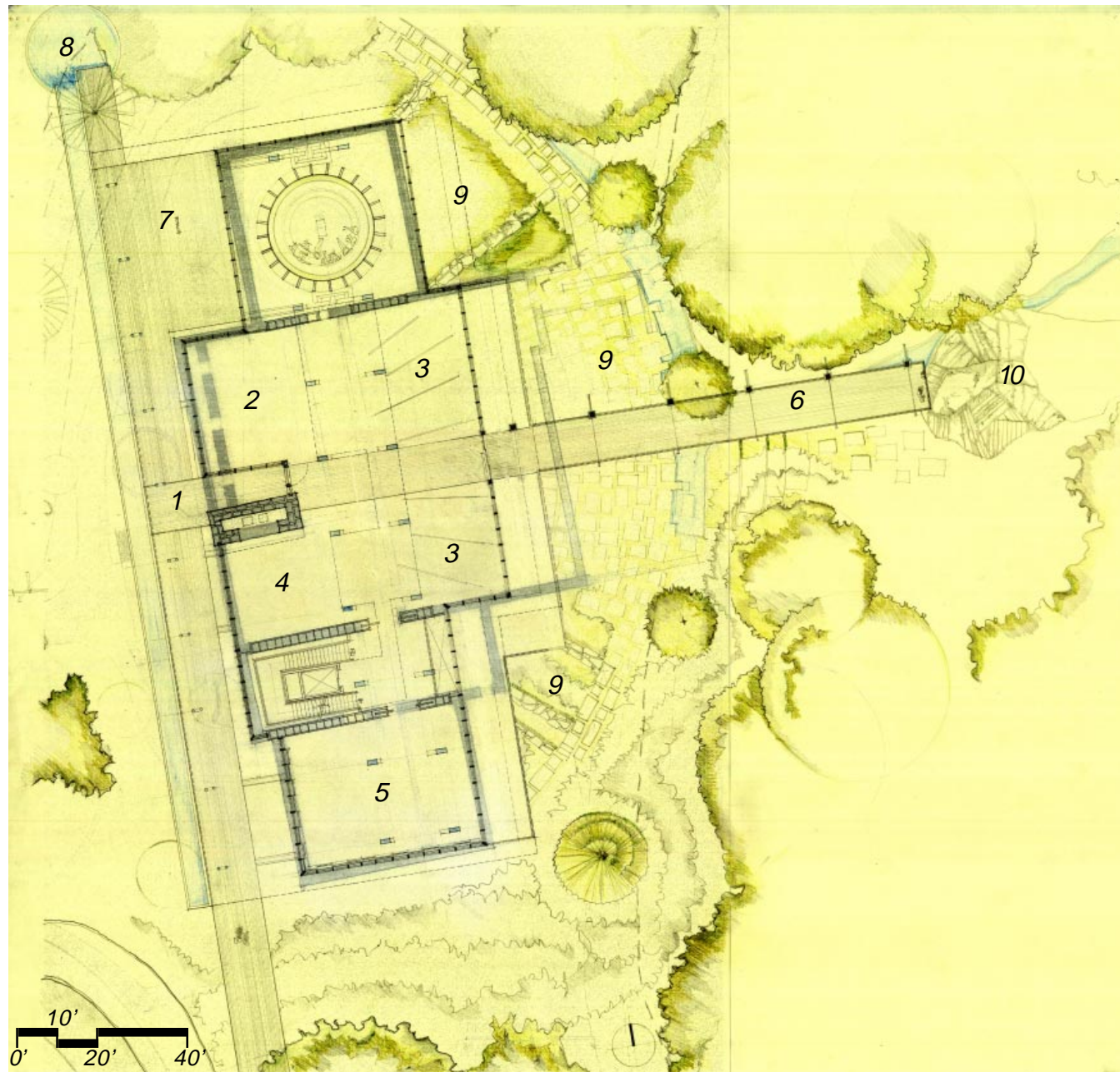

1. entry
2. information desk
3. exhibition space
4. story telling
5. staff work area
6. observation deck
7. porch
8. reflection pool
9. terraced outdoor classroom
10. rock outcrop

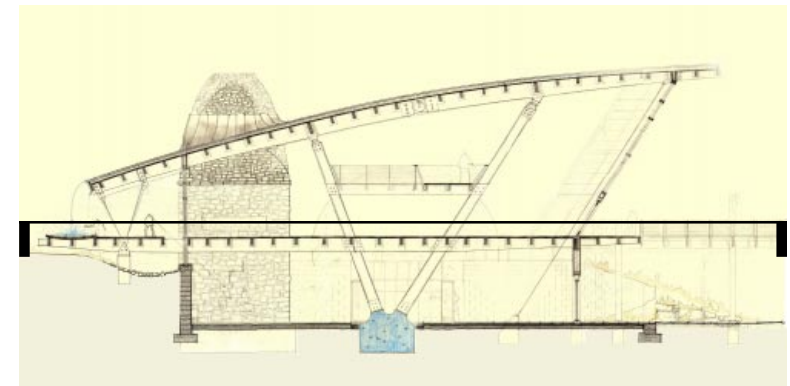

## TREE TOP LEVEL

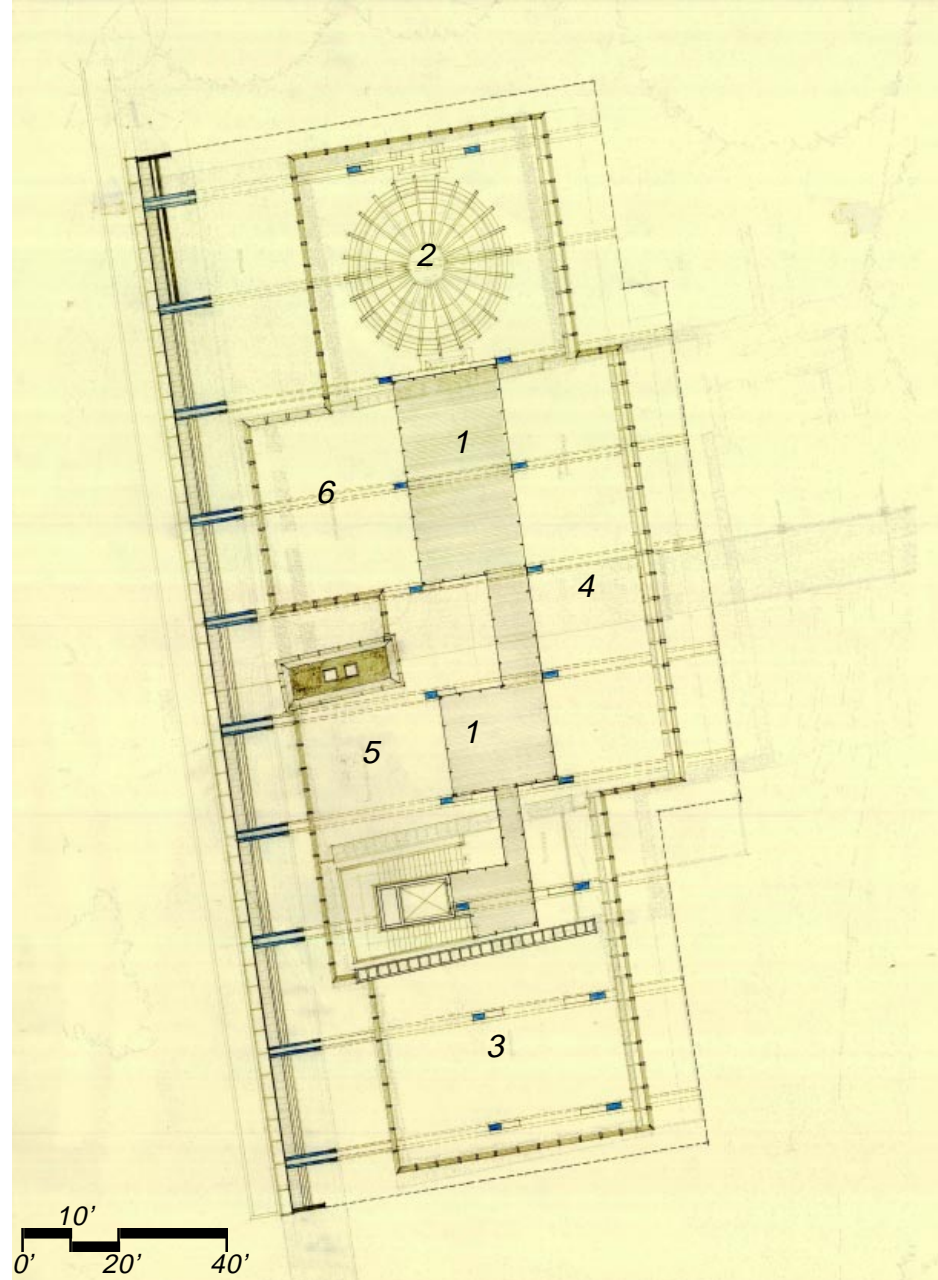

1. meditation space
2. planetarium dome below
3. staff work area below
4. exhibition space below
5. storytelling below
6. information desk below

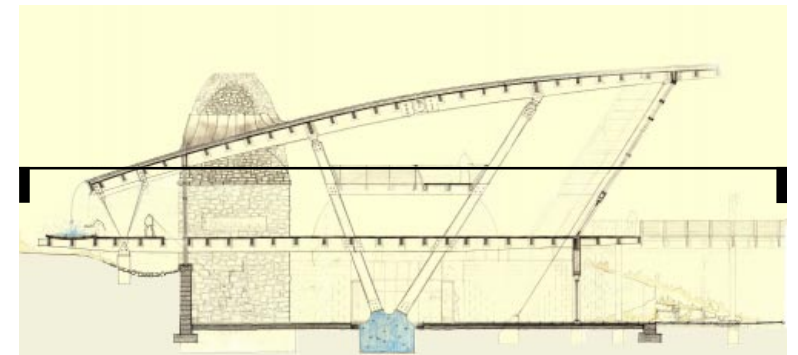
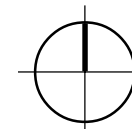

ROOF PLAN



TRANSVERSE SECTION A

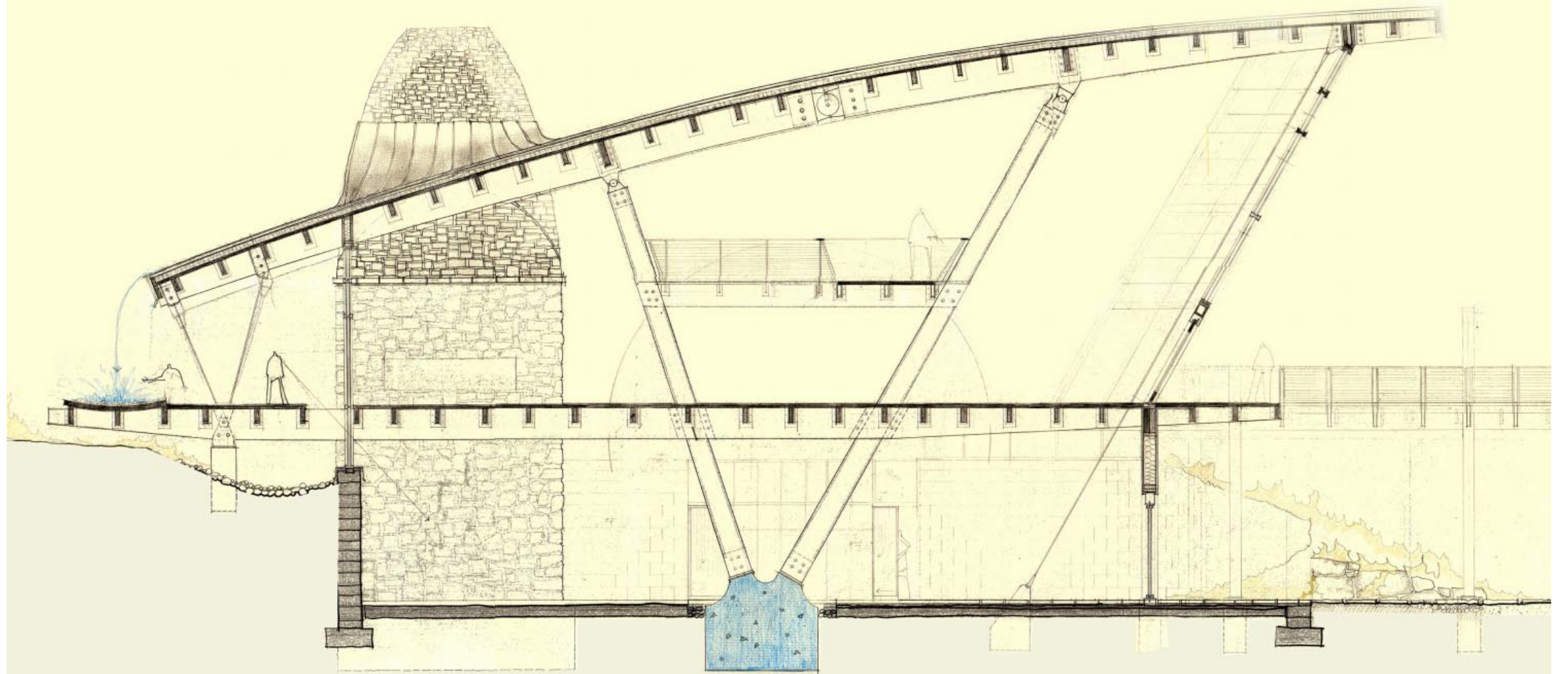

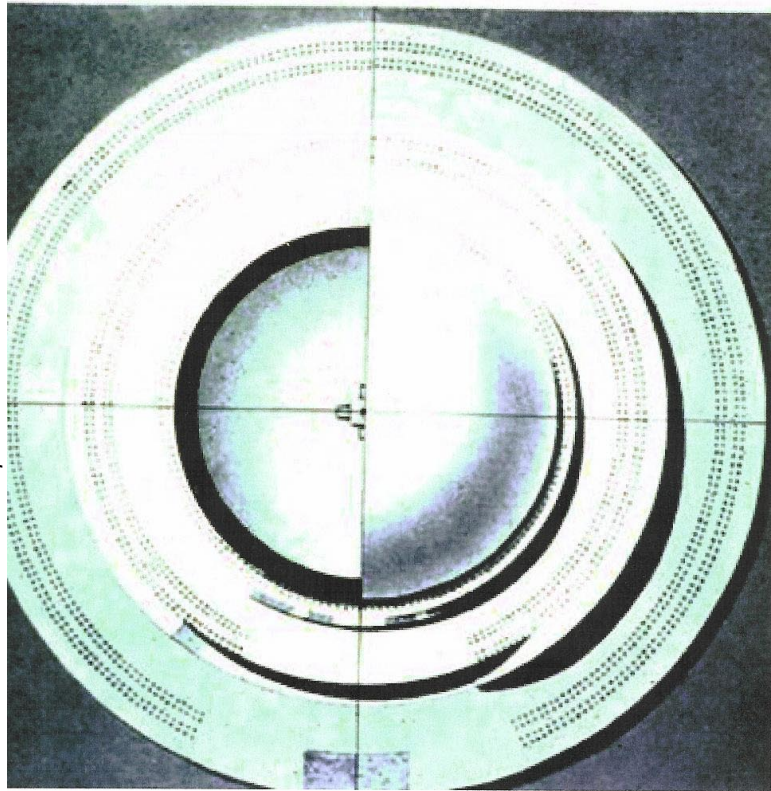
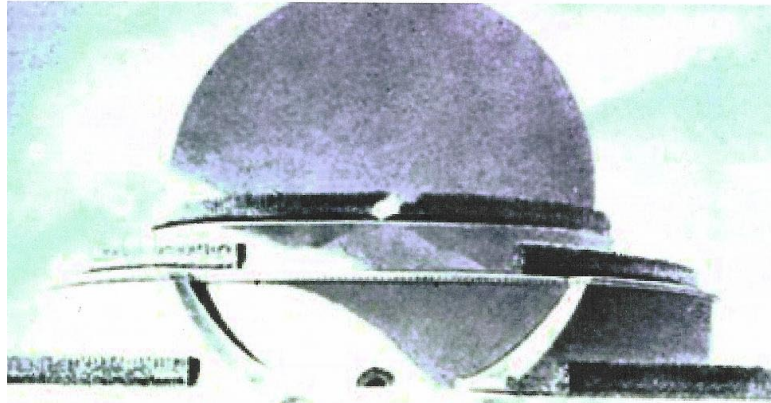

6. Boule - Newton's Cenotaph

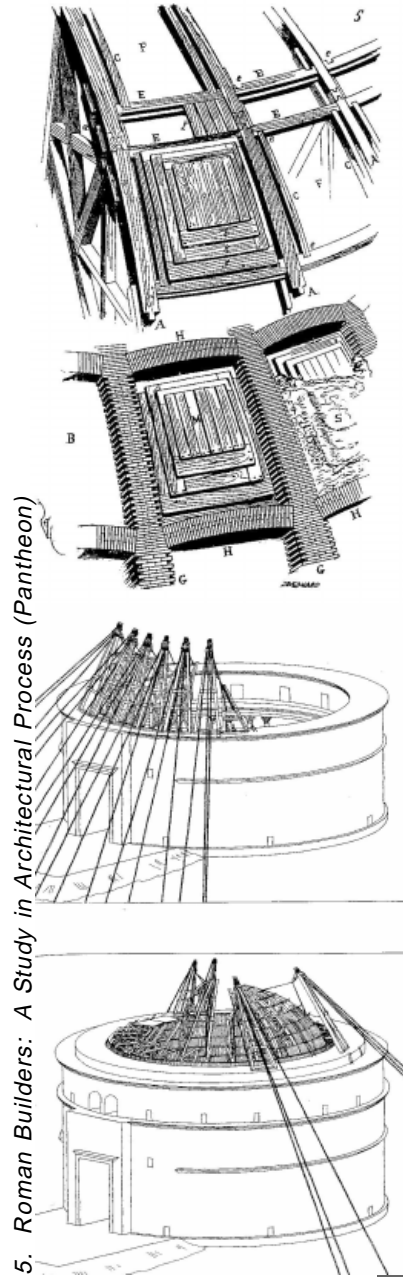

5. Roman Builders: A Study in Architectural Process (Pantheon)

*Boule's Newton's Cenotaph, and the Pantheon inspired how the planetarium will be constructed and what its meaning is within the nature education center. Both these structures are translations of the relation between man and cosmic space into architecture.*

*The planetarium serves as an astronomy laboratory, allowing visitors to study the sky under ideal conditions. This will be the only planetarium in the national park system. It's meant to stimulate and foster an interest in the sky and stars. Although it is not the purpose of the planetarium's programs to present a great wealth of astronomical information, certain fundamental concepts are woven into the fabric of each program, concepts which are basic to a proper understanding of the sky.*

*With a dome-shaped ceiling designed to reflect light, the planetarium can duplicate the motion of the stars and planets. The Rock Creek's planetarium will show the night sky as it appears in the Washington, D.C. area for the specific date and time of the program.*

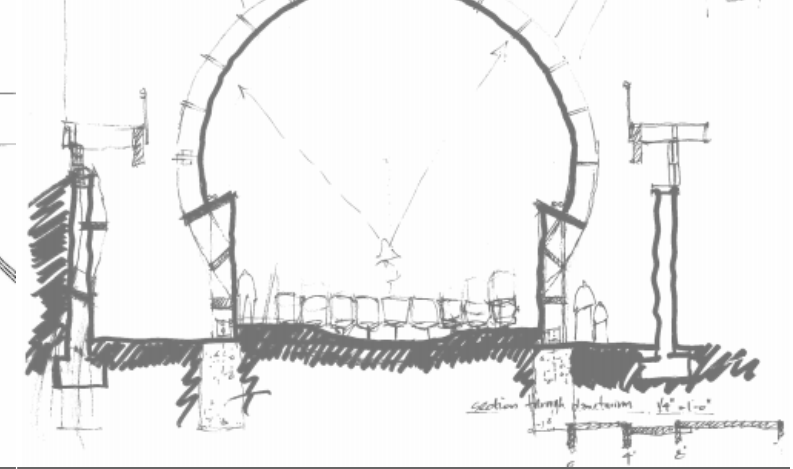

TRANSVERSE SECTION B

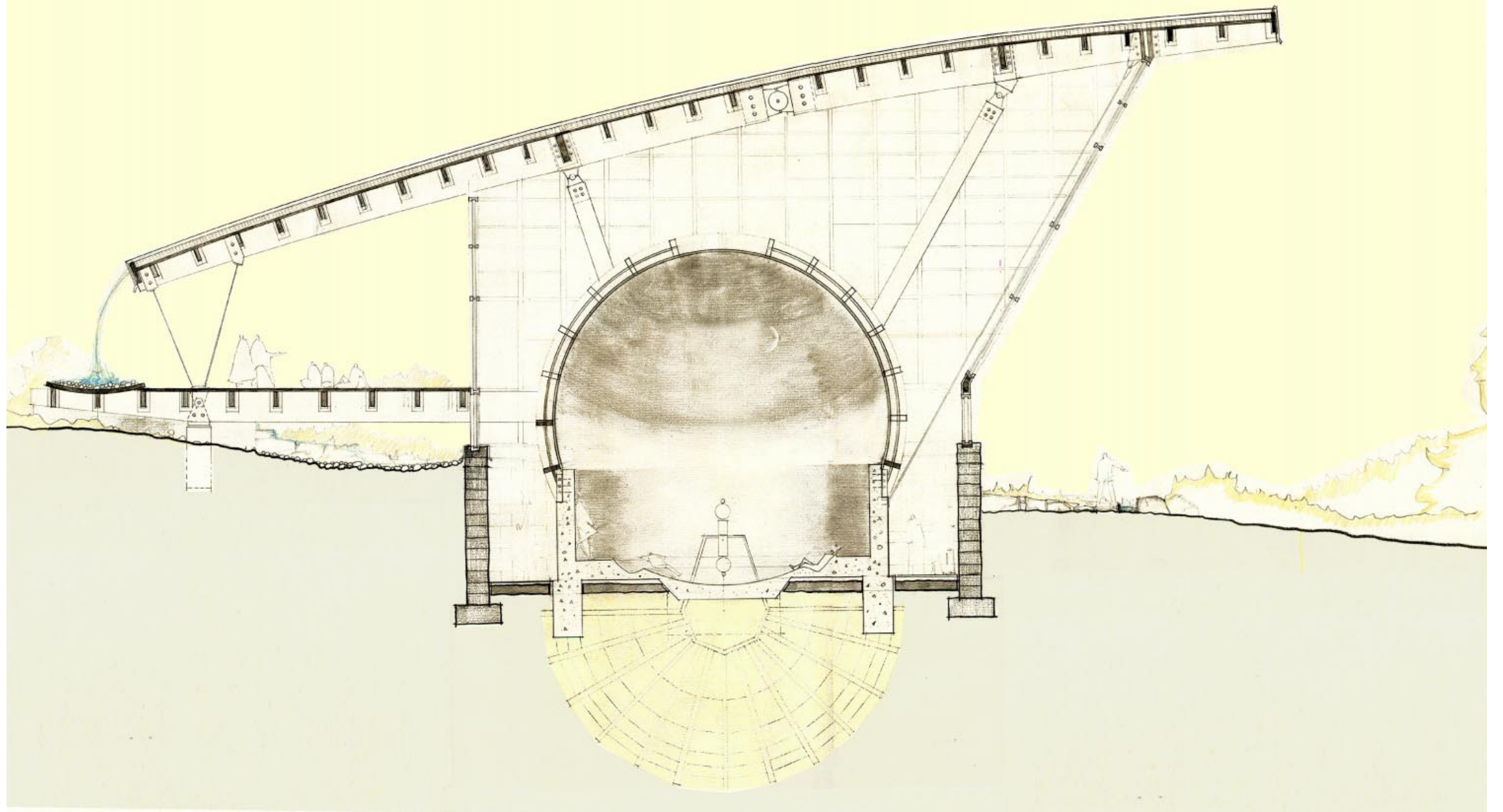

LONGITUDINAL SECTION

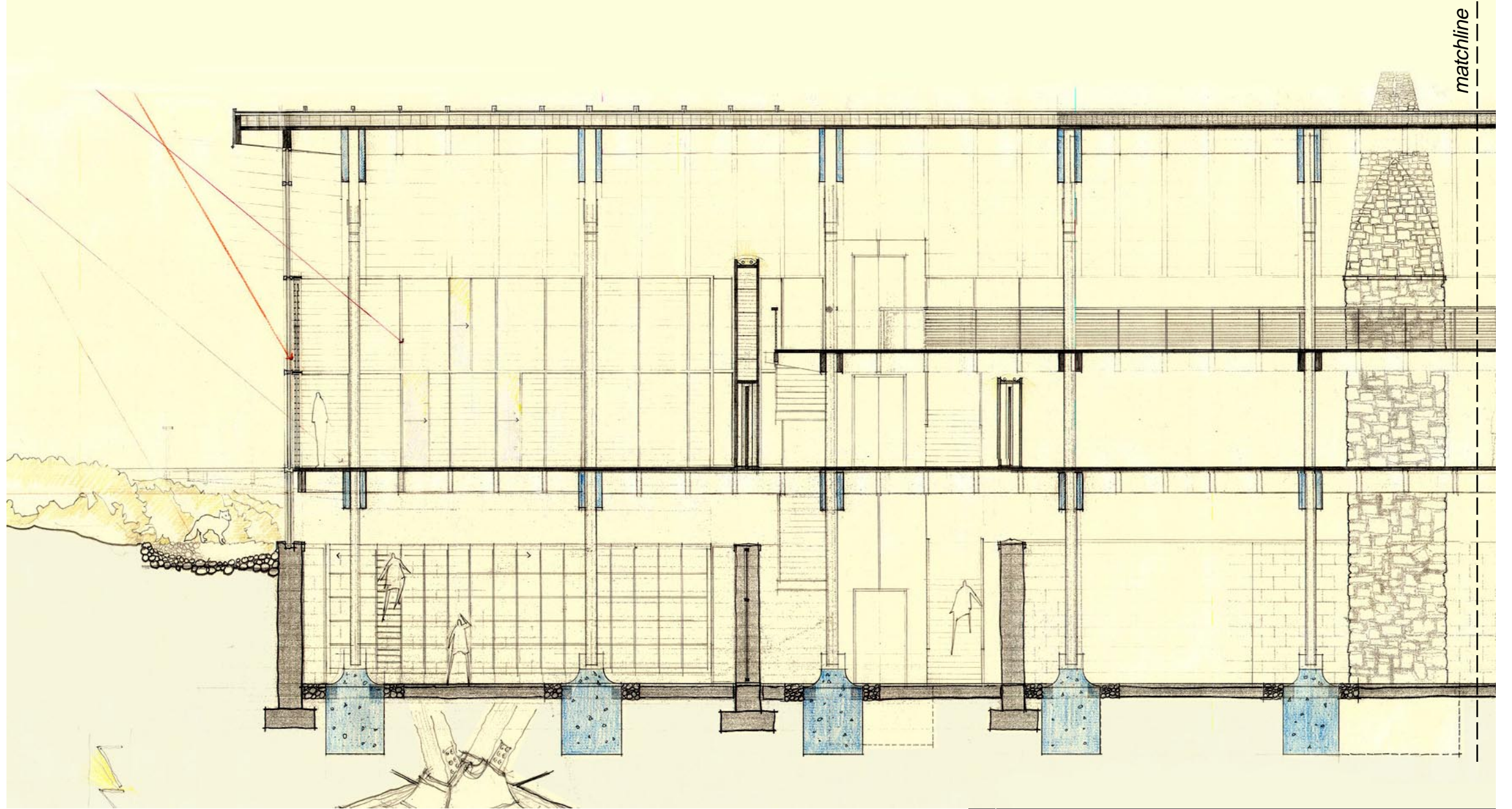

matchline

LONGITUDINAL SECTION

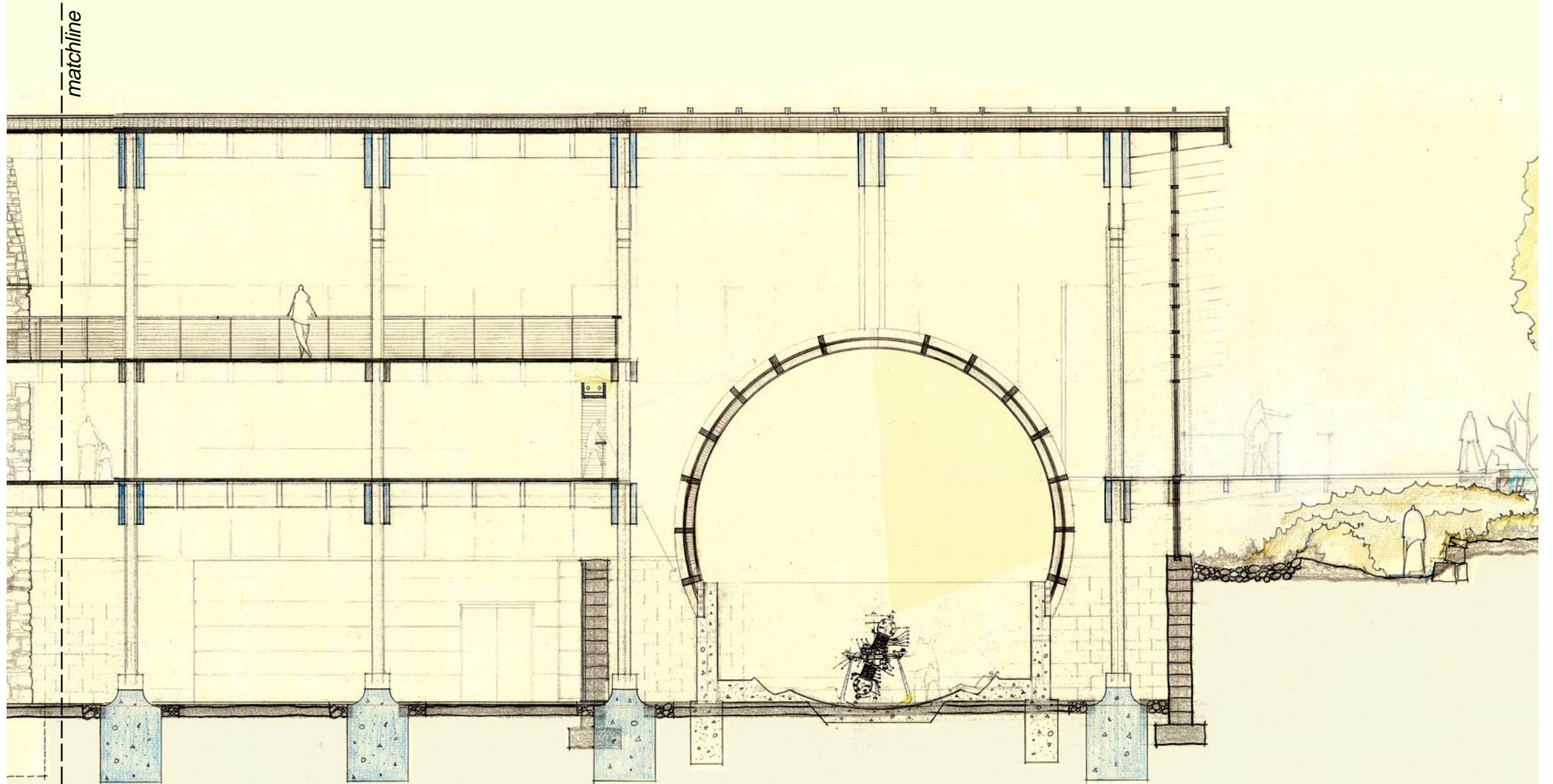

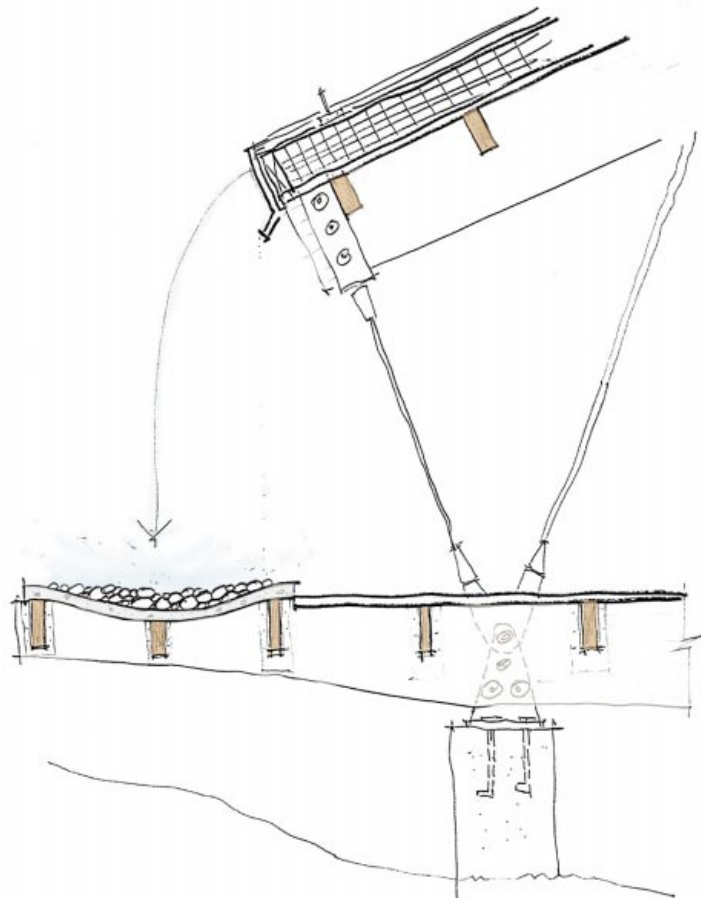

*gutter detail*

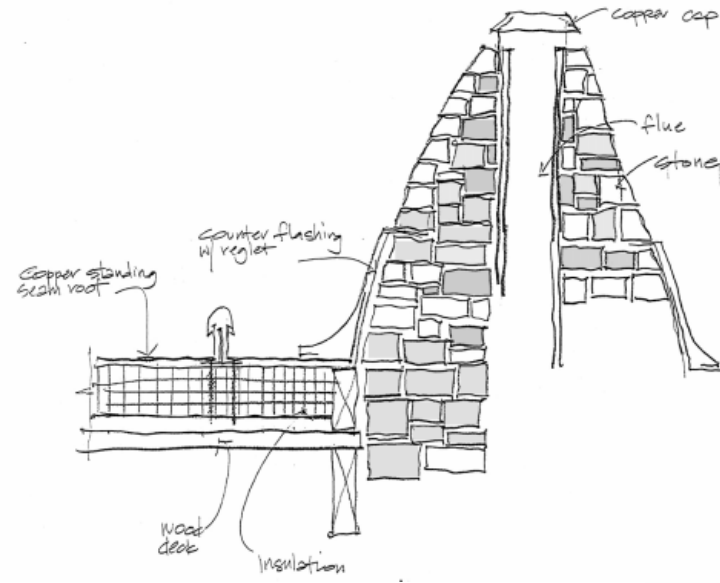

*flashing detail at stone chimney*

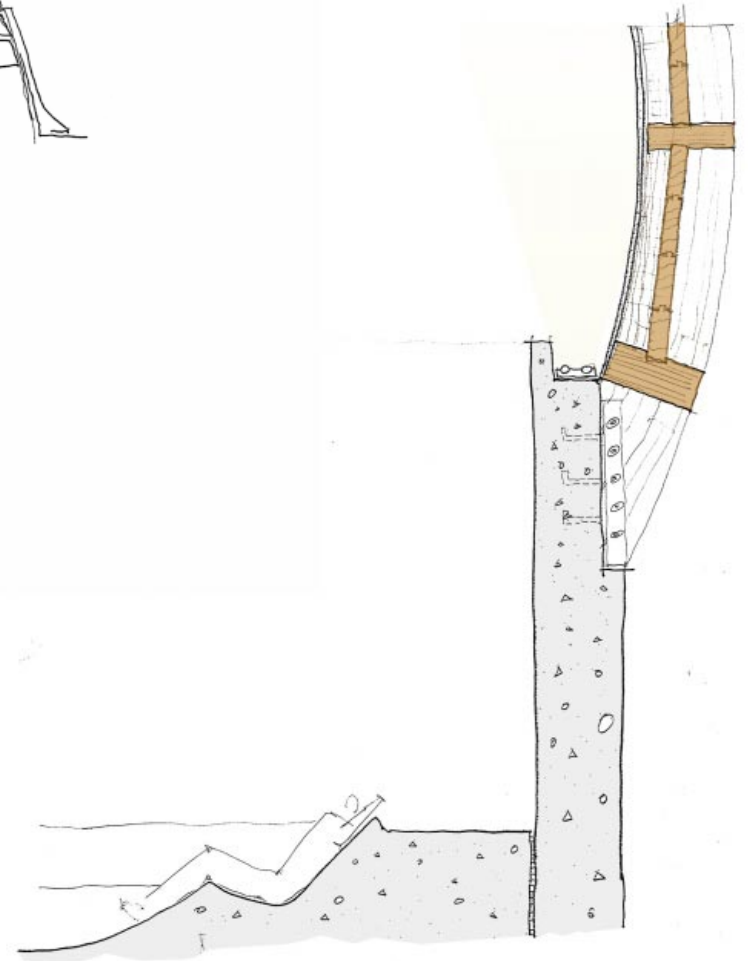

*partial wall section at planetarium*

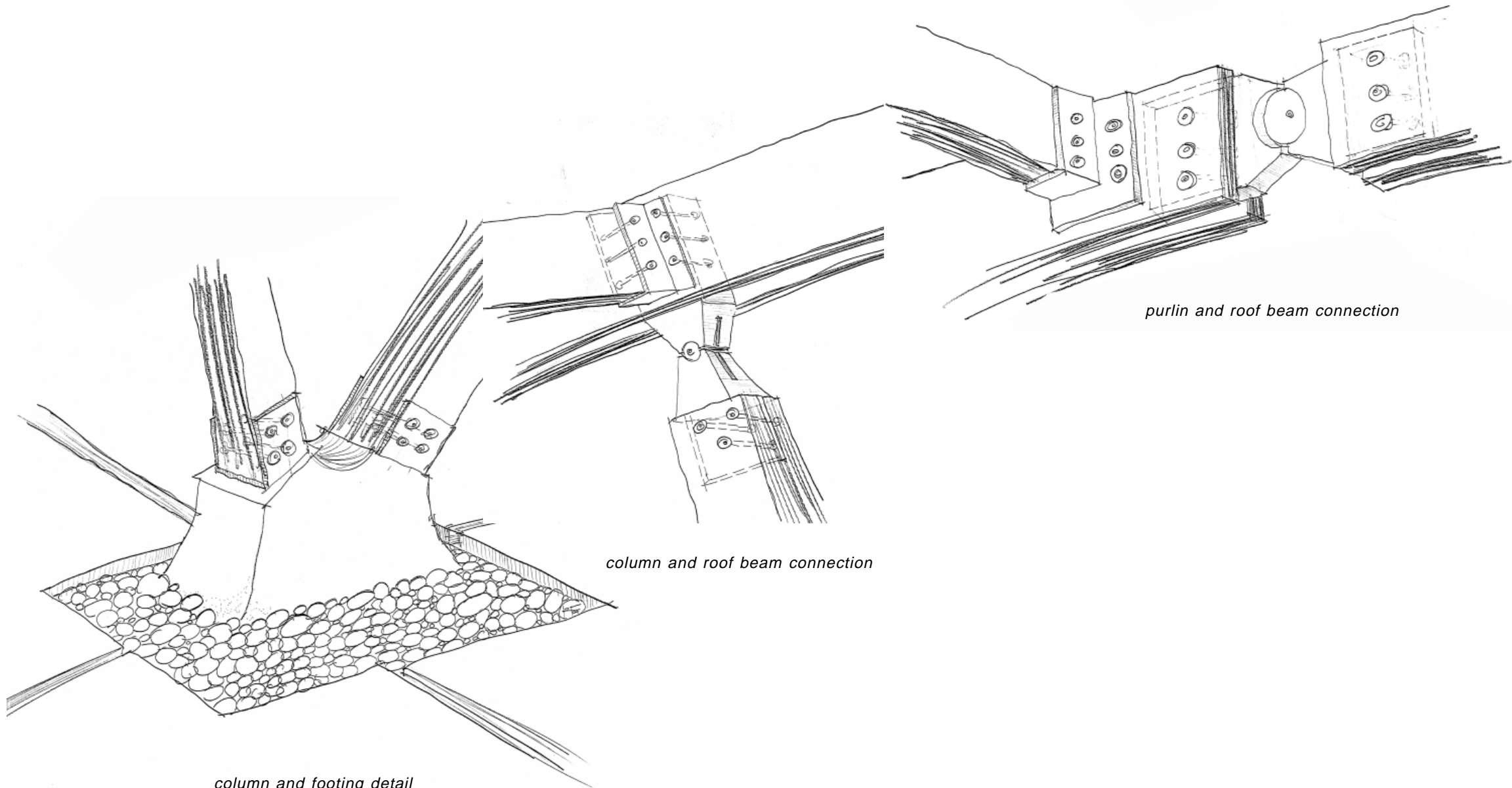

*column and footing detail*

*column and roof beam connection*

*purlin and roof beam connection*

SOUTH ELEVATION

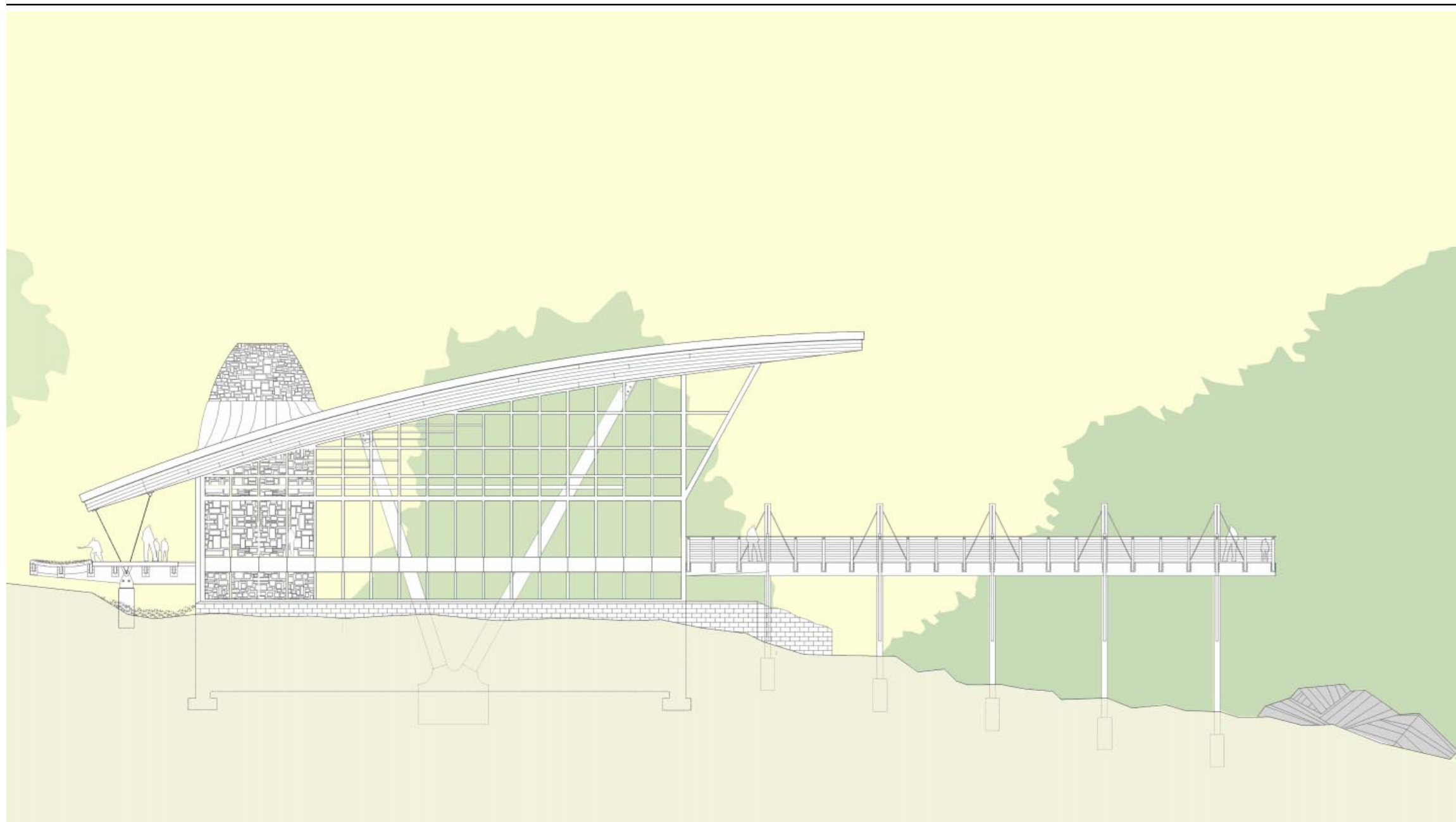

EAST ELEVATION

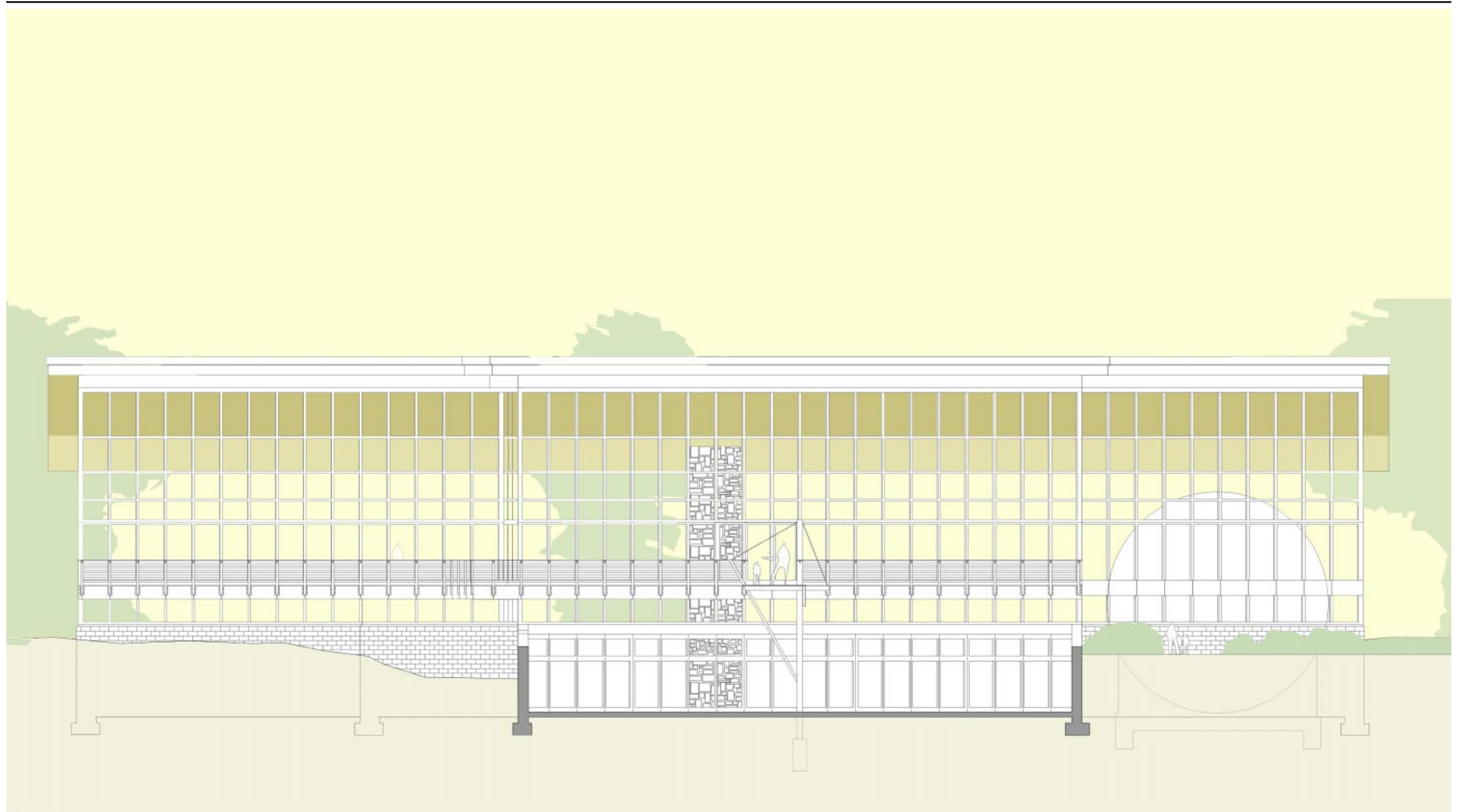

NORTH ELEVATION

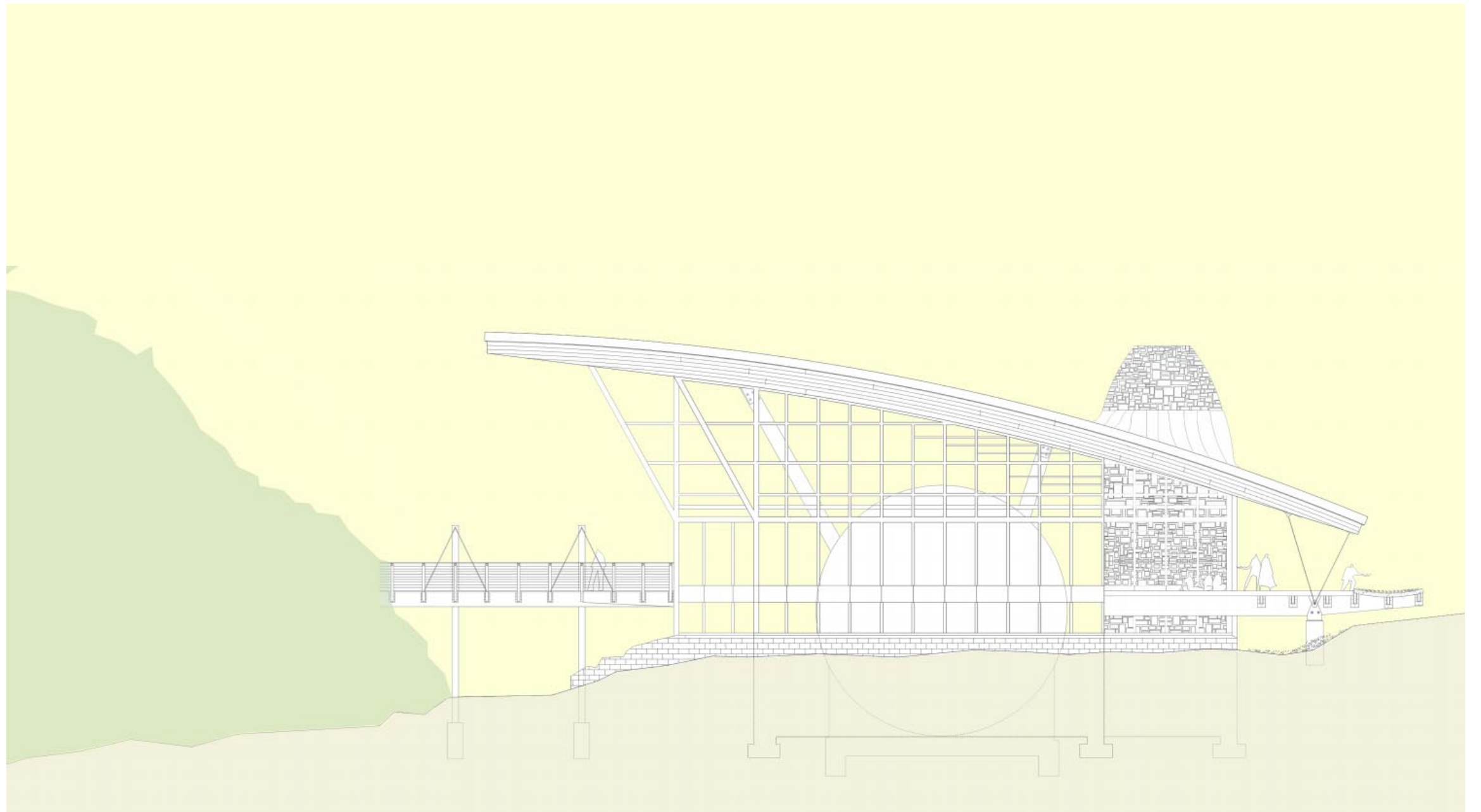

WEST ELEVATION

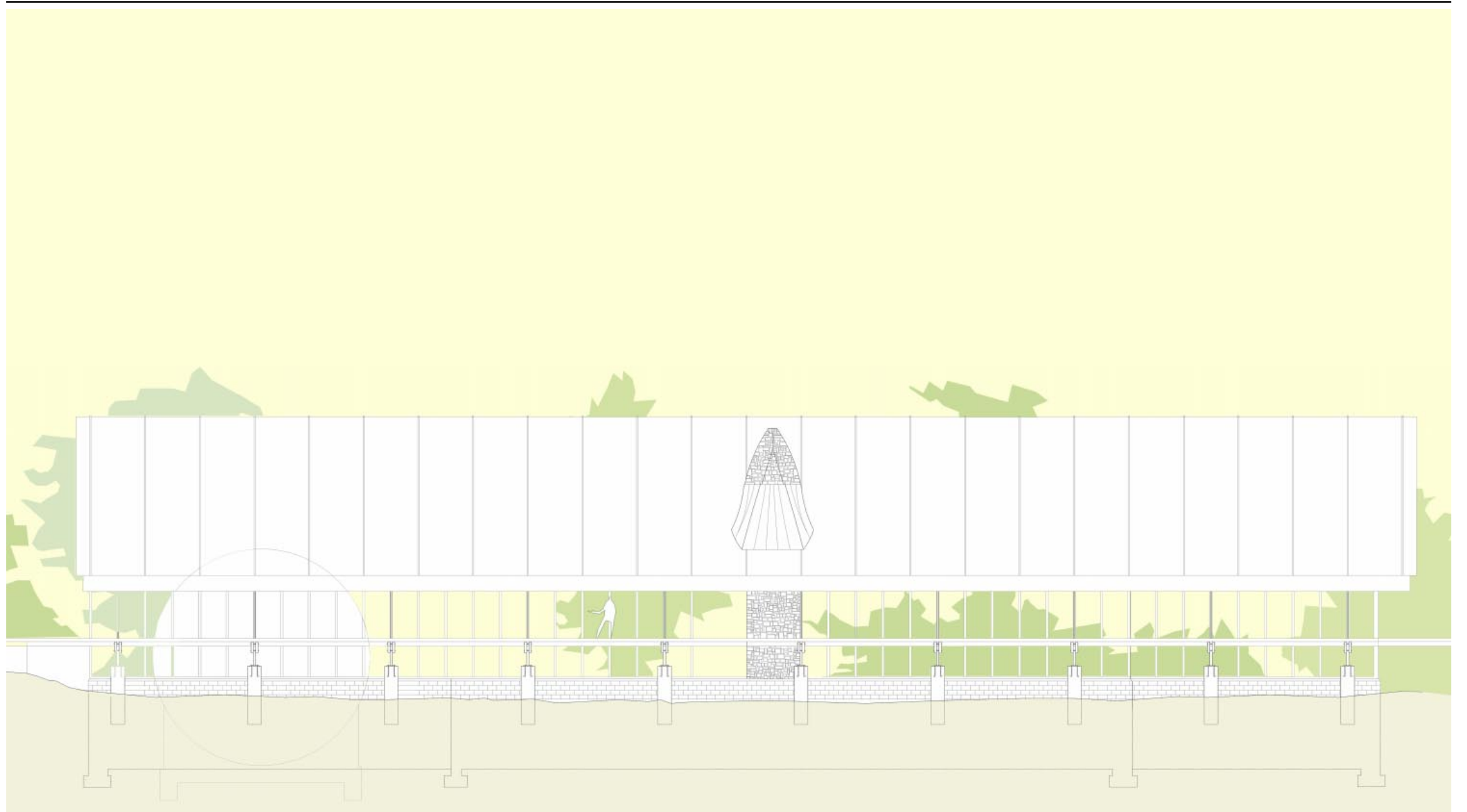

# SECTIONAL MODEL

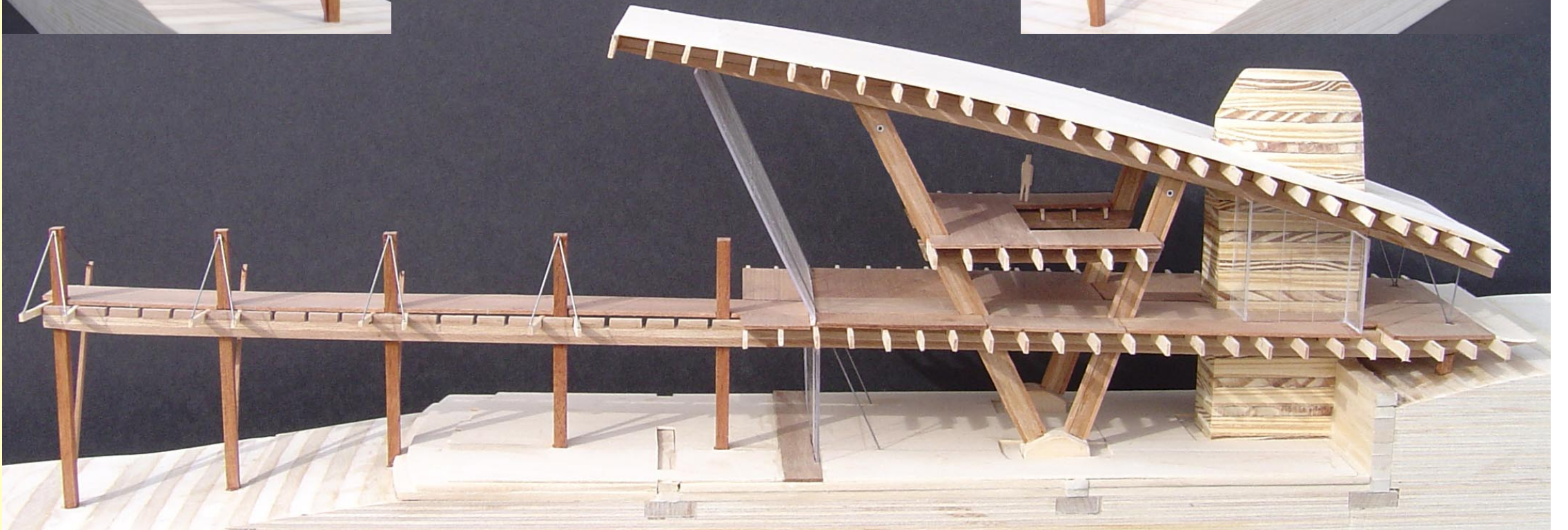



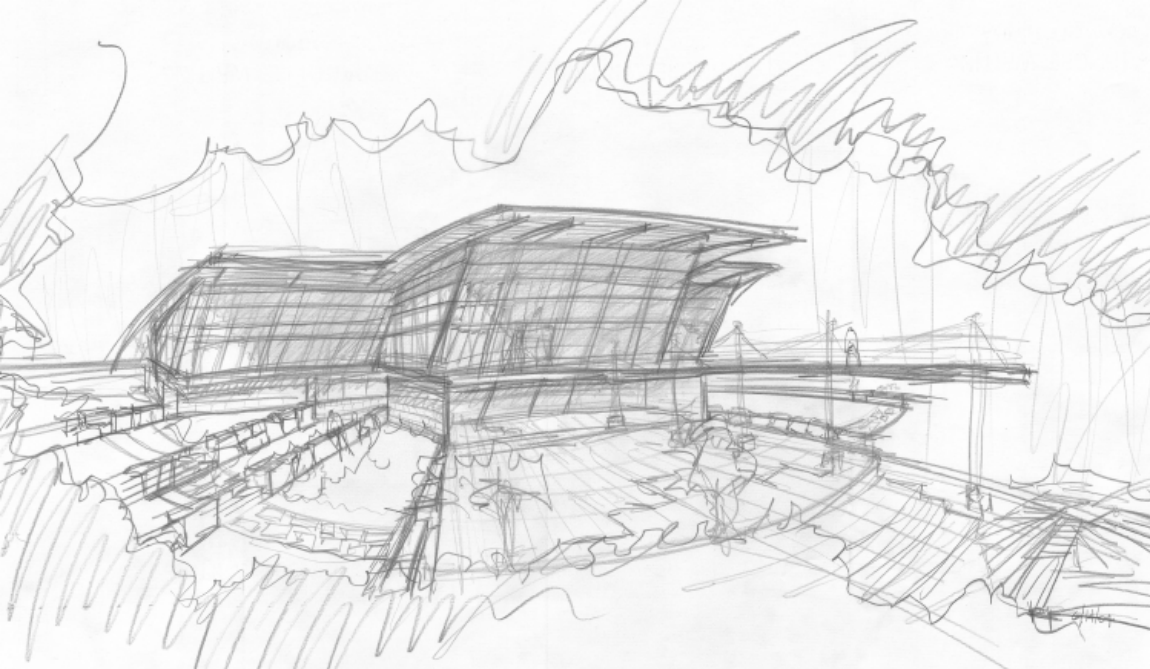
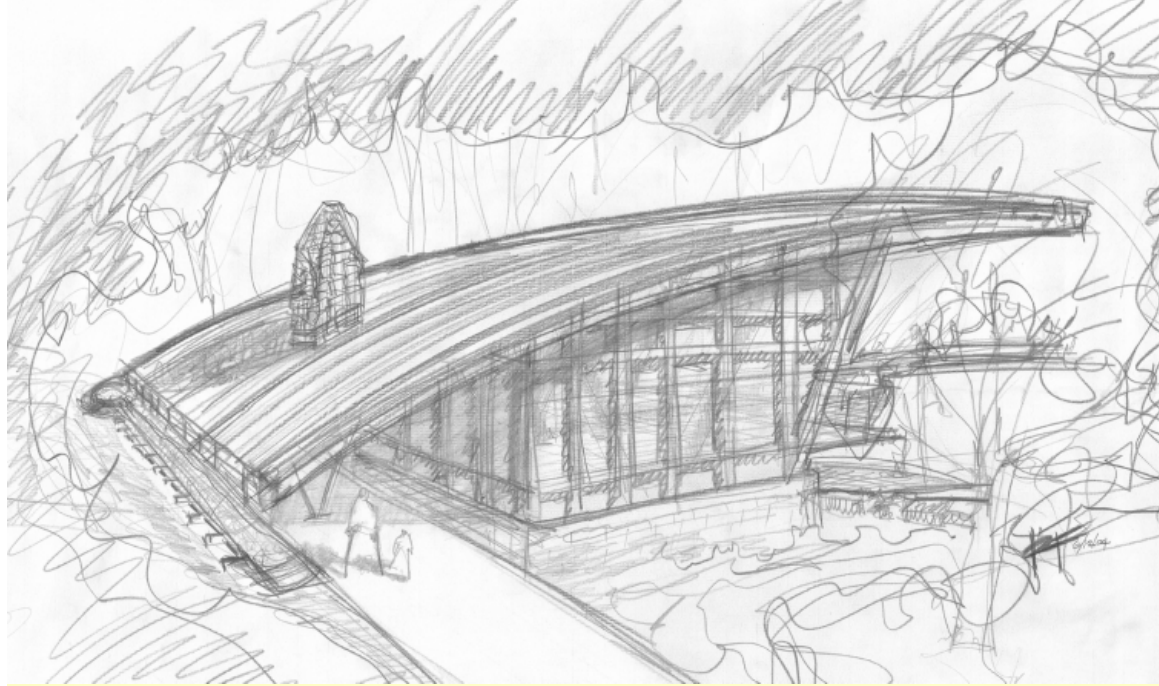

Hearn, M. F., 1990. *The Architectural Theory of Viollet-le-Duc: Readings and Commentary*. The MIT Press, Cambridge, Massachusetts.

Torg, Lilla, "Exhibition: Santiago Calatrava"

*Body and Building: Essays on the Changing Relation of Body and Architecture*. The MIT Press, Cambridge, Massachusetts.

Emerson, Ralph Waldo. *Emersons Essays*. Merrill and Baker, New York and London.

Taylor, Raubn M., 2003. *Roman Builders: A Study in Architectural Process*. Cambridge University Press, Cambridge, Massachusetts.

Boullé: [www.ar.utexas.edu/av/arc308/geo/boullé1.html](http://www.ar.utexas.edu/av/arc308/geo/boullé1.html)

Rosenau, Helen, 1976. *Boullé and Visionary Architecture*. Harmony Books.

**Robert Daniel Franklin**

*robertf@vt.edu*

**Education:**

**Master of Architecture**

*Virginia Polytechnic Institute and State University  
2005*

**Bachelor of Science in Architecture**

*Catholic University of America  
1999*

**Experience:**

**PSA-Dewberry**

*Fairfax, VA  
2005-1999*

**RTKL**

*Washington, DC & Baltimore, MD  
1999-1998*

**Awards:**

*Interschool Competition-Honorable Mention  
2003*

*NAIOP Best Institutional Building-Ashburn Library  
2002*

*Washington Building Journal-Honorable Mention-Ashburn  
Library  
2002*