

**Bryn Myrrdin,
A Temple In Time**

by

Scott A. Ogburn

Thesis submitted to the Faculty of the
Virginia Polytechnic Institute and State University
in partial fulfillment of the requirements for the degree of

MASTER OF ARCHITECTURE

in

Architecture and Urban Studies

APPROVED:



Dennis J. Kilper
Chairman

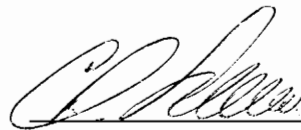

Salahuddin Choudhury

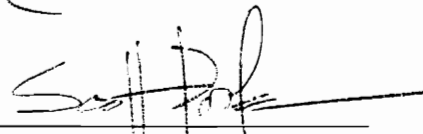

J. Scott Poole

December, 1990
Blacksburg, Virginia

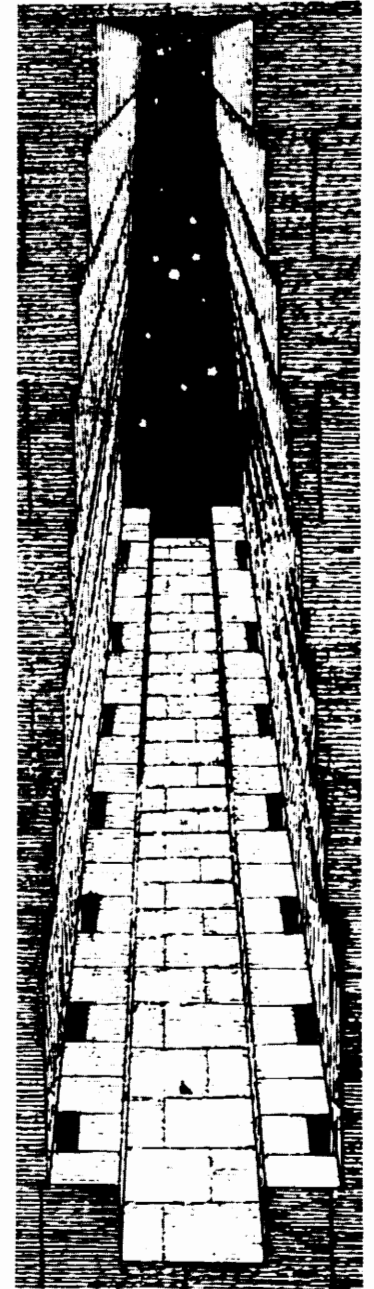

LD

5655

V85E

199

0539

0.2

Folio

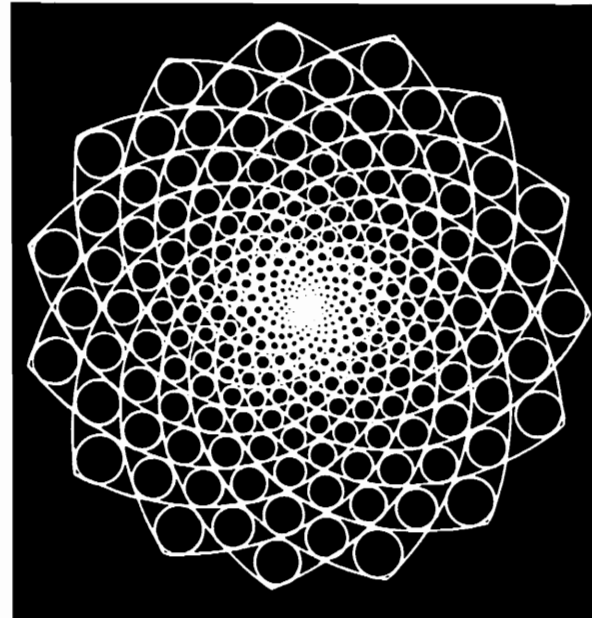

1

Speak to the stones,
And the stars answer.
At first the visible obscures:
Go where light is.

Theodore Roethke

Abstract

Bryn Myrddin, A Temple in Time

From the stars we are born, and to the stars we return. The heavens hold our heritage and our destiny. Throughout Man's history, marking the positions of the moon and stars has been essential to knowing one's place in the cosmos, to defining the cycle of seasons and Time itself. To connect Man between Heaven and Earth. In Architecture, it is fitting to celebrate the stars. To celebrate Light and the spaces contained within. To revere silence in the space created by star light.

In this Thesis, a central premise is Architecture to mark the rising and setting of the Sun, Moon, and stars. An Architecture of exploration where the forms are generated from astronomical markers, alignments from the stars. To capture a moment in time. As stars are beacons for Man's hopes and dreams, the Temple complex I propose is a beacon for Man coming together to share his visions with one another in harmony.

A world center is eventually to be built where philosophers, artists, writers, scientists, politicians, and musicians can come together to exchange their ideas and aspirations in lectures, workshops, concerts, theater, dance, and art. A place for gathering to include studios and living areas, as well as a library. A space for solitude, meditation and the pursuit of one's own dreams. A place for the Vision quest, for contemplation and spiritual renewal. Architecturally, the crystallization of sacred geometry to create a sacred space.

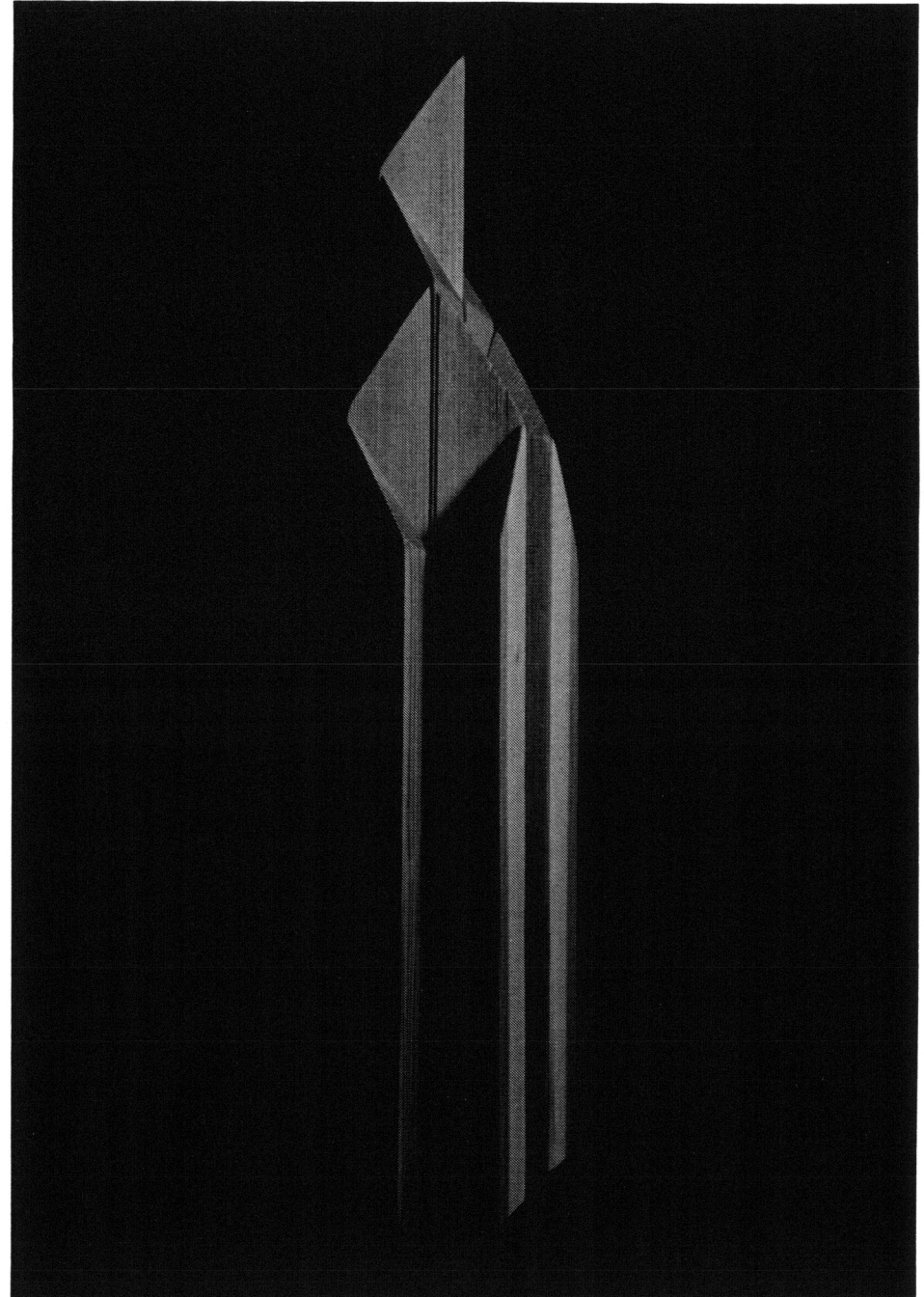

Acknowledgements

In this thesis, many people have helped me transform a vision into a reality. I greatly appreciate everyone's encouragement and help.

To my father, mother, and sister for all their continual support, love, and understanding.

To my thesis committee; Dennis, Sal, and Scott, for their direction, critique and advice, enabling me to gain better insights into the meaning and intent of Architecture.

To Heiner Schnoedt and Bill Galloway for coming by my desk any time of the day or night to provide their own unique insights into Architecture, and for all their help in the computer lab.

To Professor Brian Dennison, Physics Department at Virginia Tech, for his consultation on the astronomical alignments at my site.

To the St. Andrew's Society of Washington, D.C. for their generous scholarship which enabled me to travel to England and Scotland to research the ancient megalithic stone circles and their astronomical alignments.

To Barry Kiracofe for the use of his land and cabin for the site of Bryn Myrrdin.

To Katherine Sharp for her guidance on the road to enlightenment. An inspiration always.

To the Ancient Ones, who have throughout time marked Man's relationship to the stars in stone.

To the mysterious, omniscient, omnipotent creative Force in the universe we call God who dwells within us - an inseparable; all-knowing consciousness of Love.

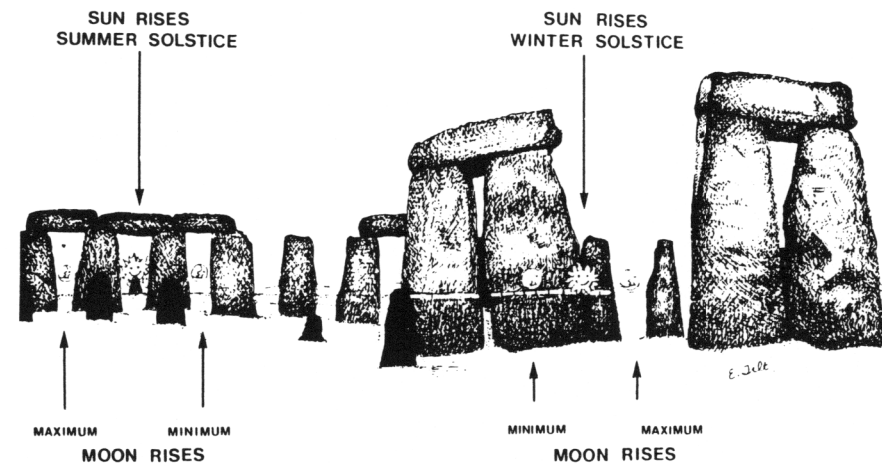

The standstill limits of the moonrise and the solstice limits of the sunrise as seen from the center of Stonehenge indicate that considerable movement of the sun and moon could be observed on the horizon over the course of their cycles. Stones block the view of some of the southern risings, but these were probably not intended to be seen from the monument's center. (Griffith Observatory)

3



PLATE 22. A wide-angle view of the midwinter sun in the sunrise trilithon, December 1964.

4

Table of Contents

Abstract iii

Acknowledgements iv

Historical Precedents 1

Introduction 8

Site 9

Plaza of the Sun 12

Temple of the Moon 21

Study Models 23

List of Illustrations 29

Selected Bibliography 30

Vita 32

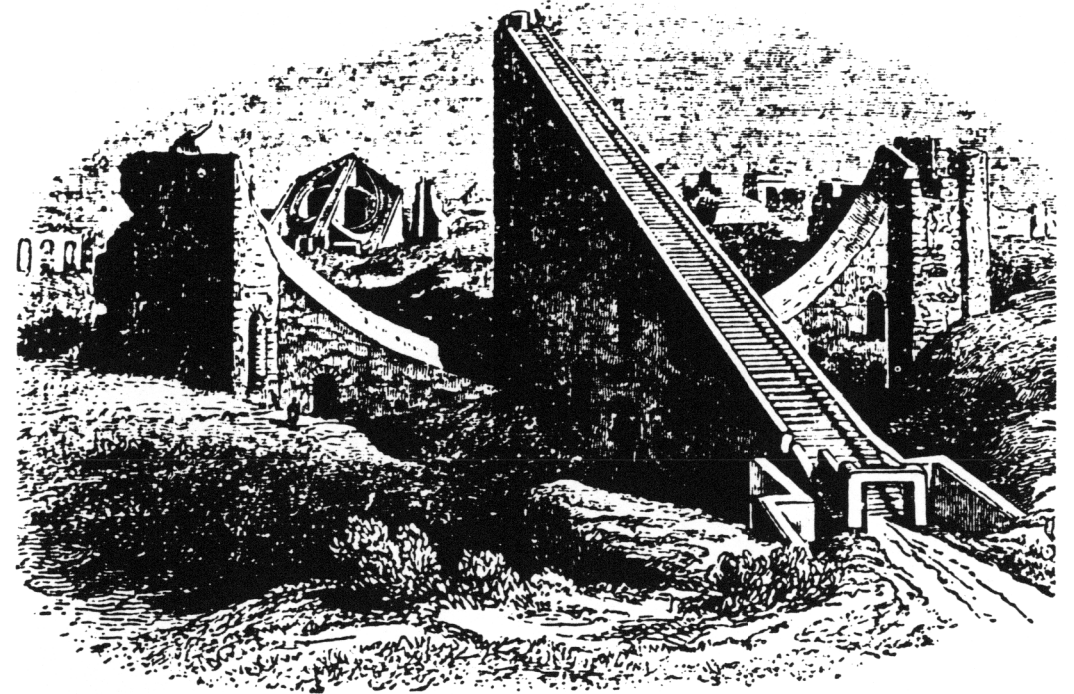

Indian astronomical observatory erected at Delhi by the Maharajah of Jaipur consists of a 56-foot triangular

structure which casts a shadow onto an arc of masonry calibrated in hours, minutes and seconds (top).

Another Indian observatory at Benares, known as Yantra, provided fixed angles to check the position of the stars.

Historical Precedents

Haiku

Dark clouds
Hide the mountain peaks,
Shifting wind amidst
The Sun's rays,
Render shadows
Into Light.

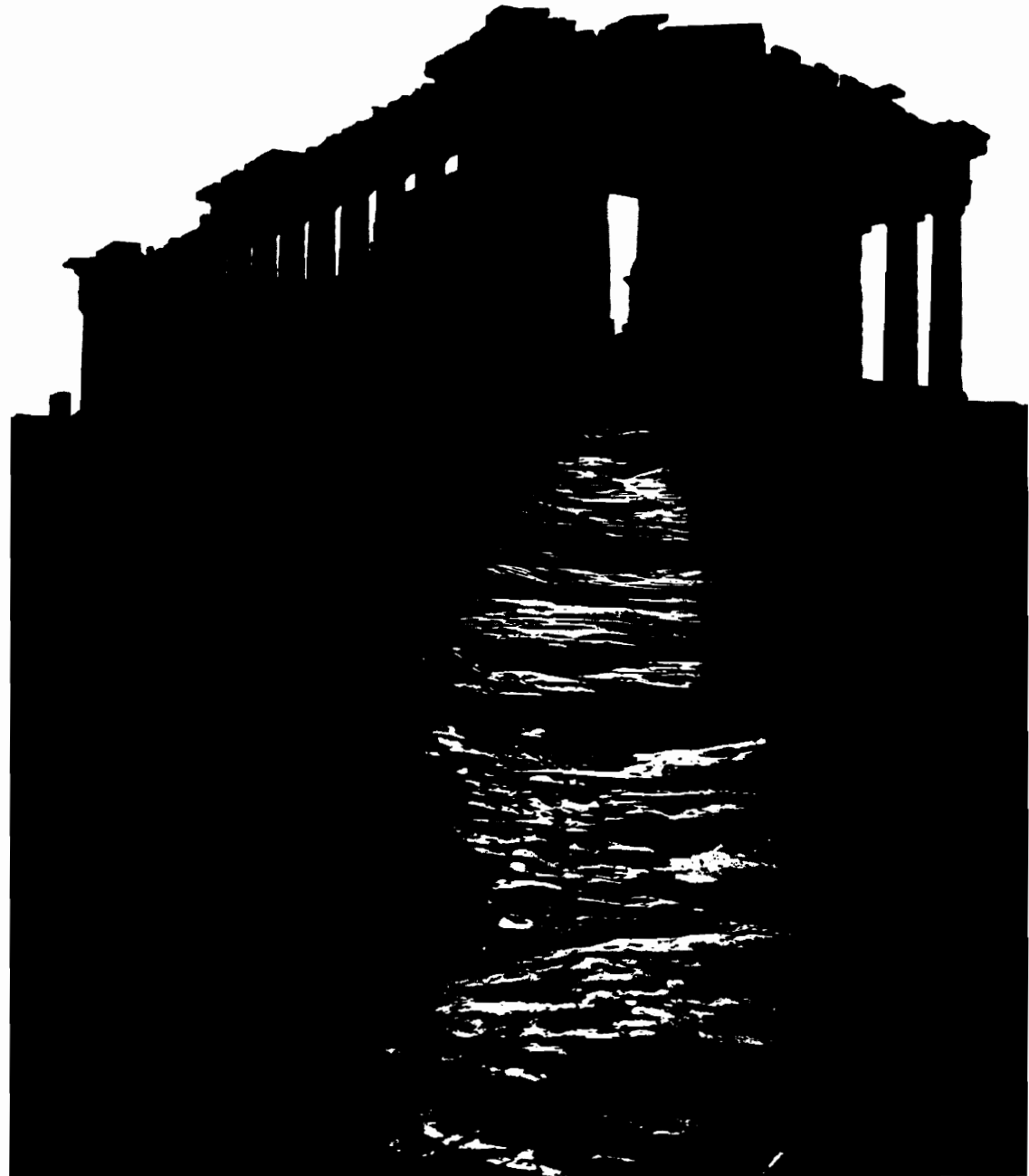

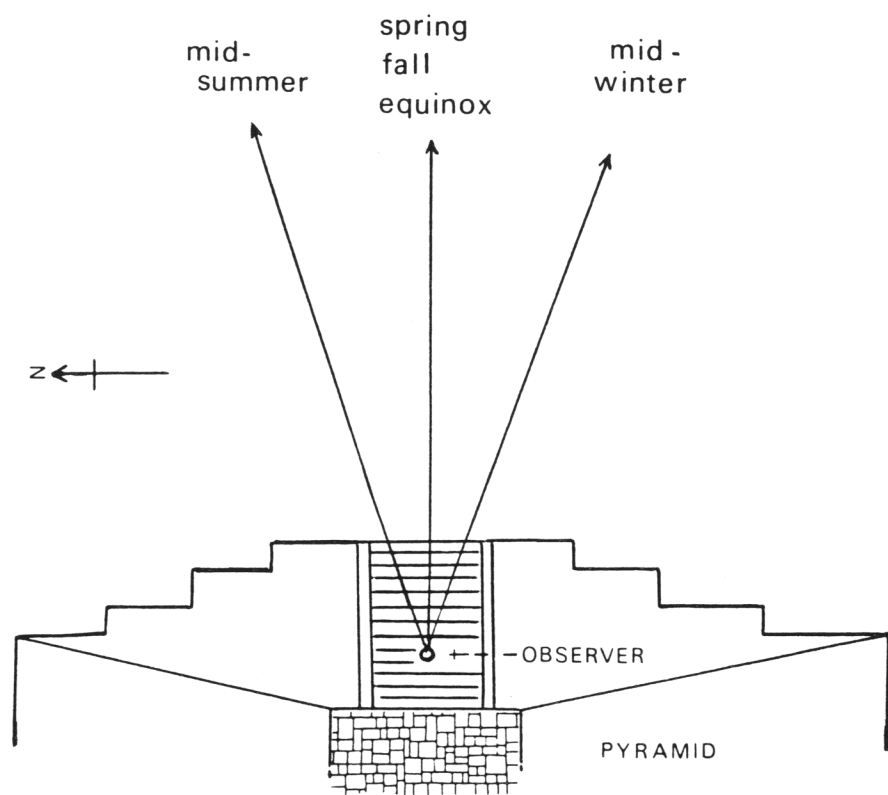
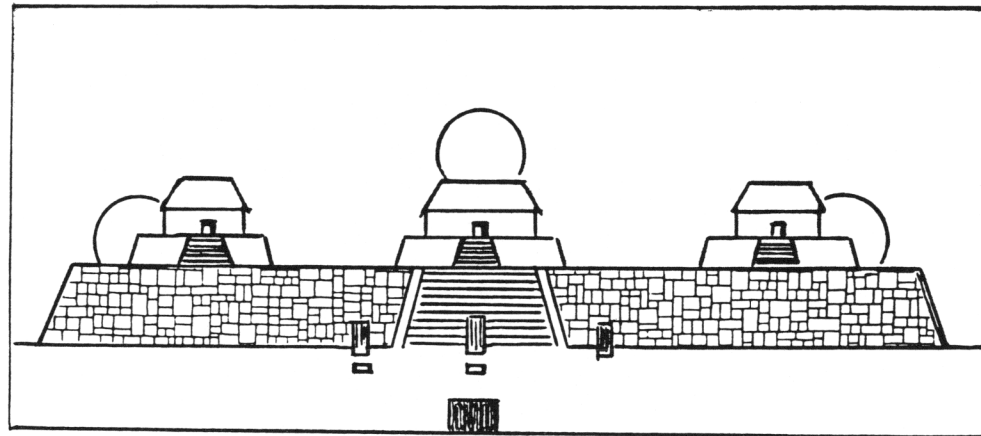
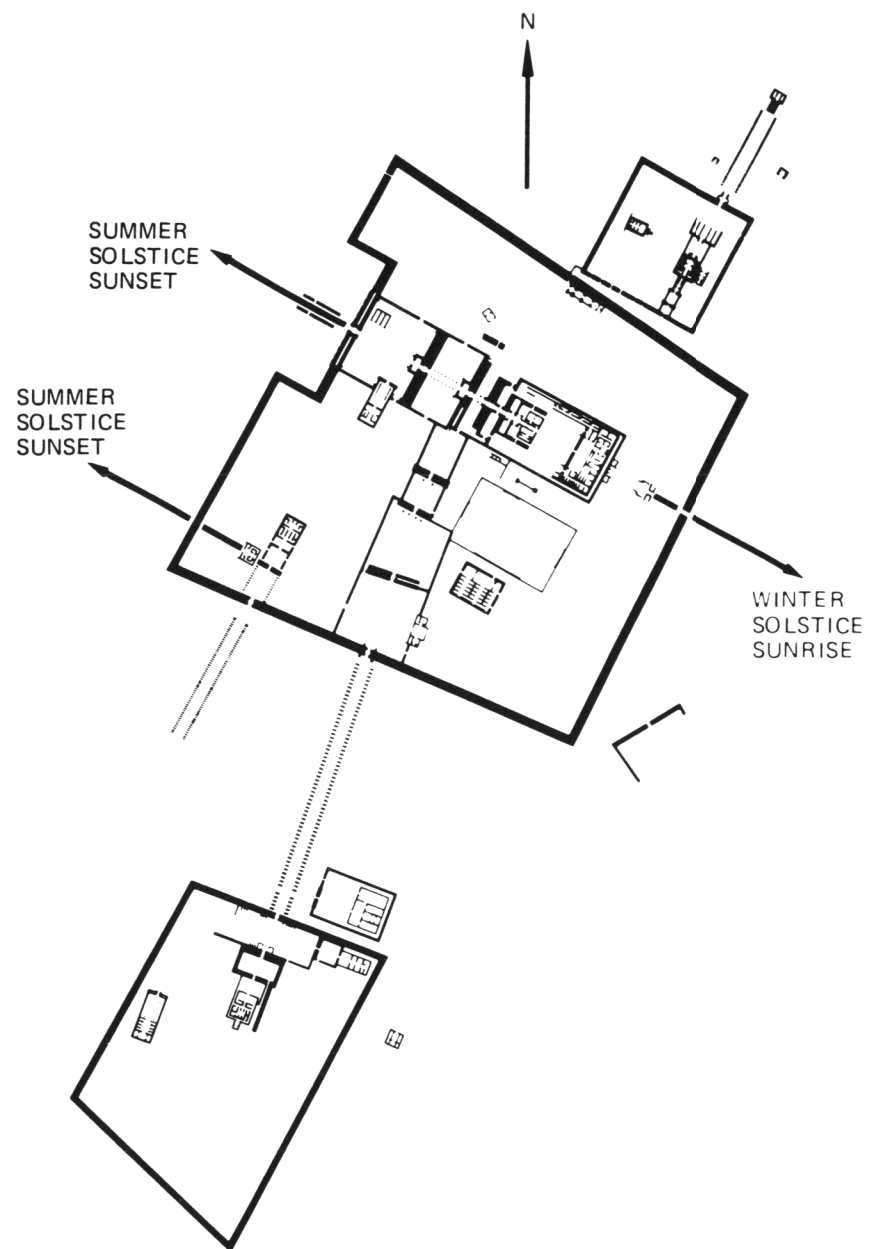

FIG. 31. Three temples marking the seasonal sun at Uaxactun, Guatemala.



The Caracol at Chichén Itza, in Yucatan, included windows in its upper portion that could have been used for astronomical observation. (Robin Rector Krupp)



Sir Norman Lockyer identified three solstitial alignments at Karnak, in Upper Egypt. Two indicated the summer solstice sunset, he claimed, and the third pointed toward the winter solstice sunrise. (Griffith Observatory, Joseph Bieniasz, after Sir Norman Lockyer)



Temple of Luxor, View of the hypostyle hall from the inner court

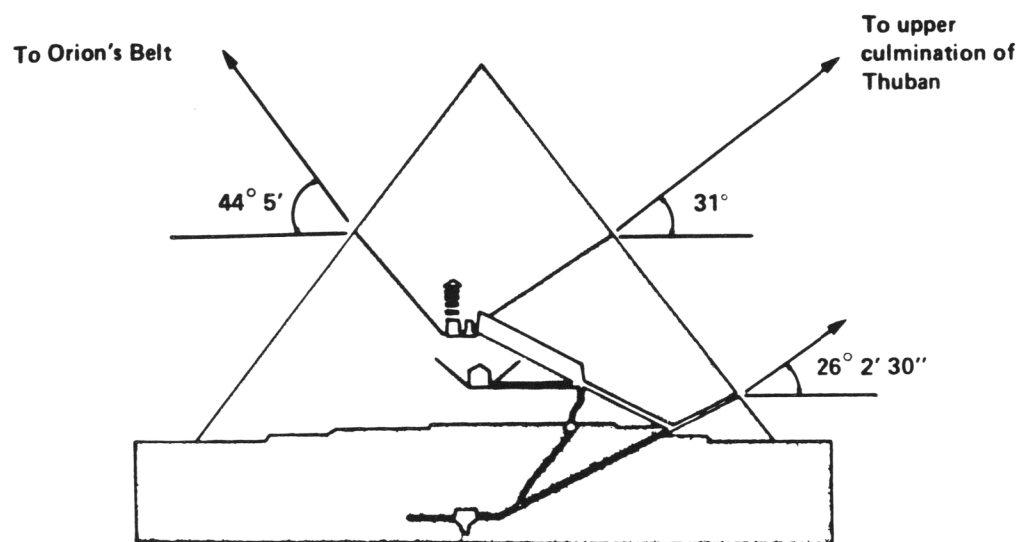

The Great Pyramid of Giza

The so-called ventilation shafts of the King's Chamber in the Great Pyramid are shown as solid lines which emerge from that chamber at angles of 44 degrees 5 minutes on the south and 31 degrees on the north. The Descending Passage also emerges from the north face, at an angle of 26 degrees 2 minutes 30 seconds. The "ventilation shafts" appear to have astronomical significance and may have been intended to conduct the soul of the dead pharaoh to the circumpolar stars in the north and to the stars of Orion's belt in the south. (Griffith Observatory)

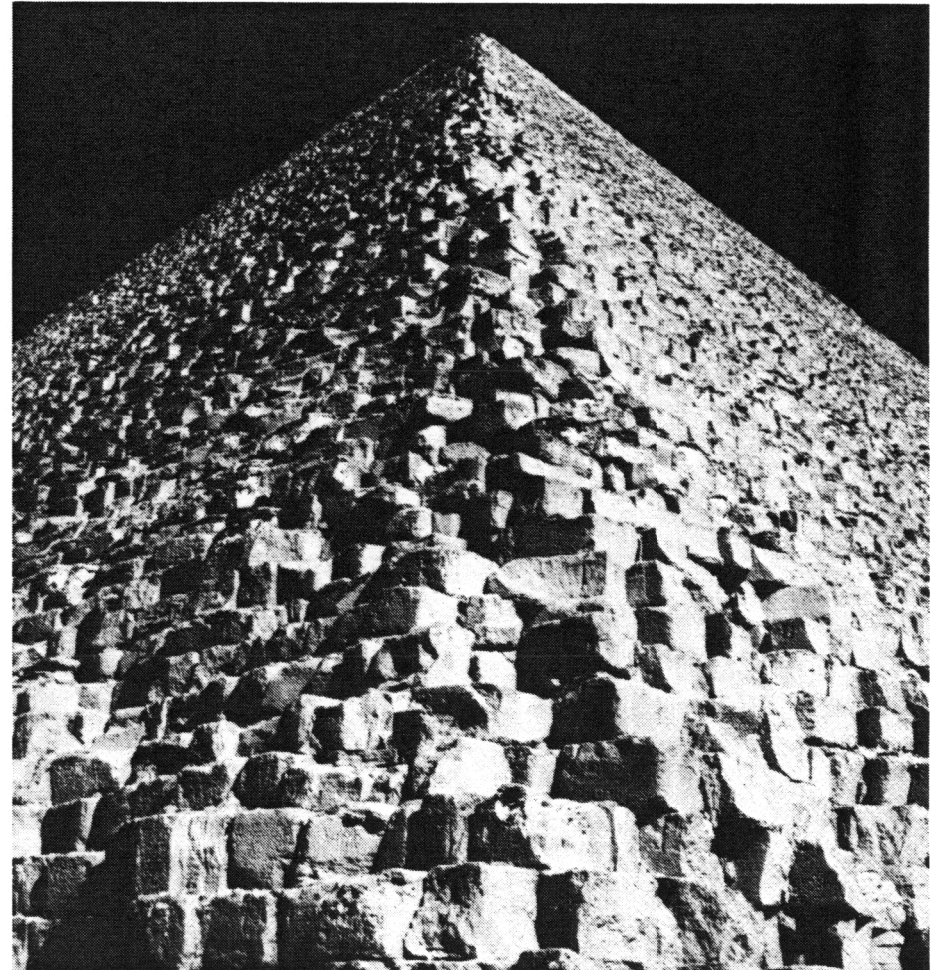

At sunrise,
Giant stones
Emerge from the desert.
In a Geometer's dream,
The Mountain rises.

Stonehenge

Sentinels of stone stand tall
In the rushing wind off Salisbury Plain,
Monoliths carved to a fine edge,
Curved lintels; mortise and tenon,
Resting calm on a circle
Of blue grey sarsen stones,
Druids humble offering
To God with Love,
Marking Time for Man,
Eternal Tones
Timeless in antiquity,
Bats flitting among the giants
In a crimson sunset,
Between the trilithons,
A star gate,
The Moon a sliver at summer solstice,
Ruins remain sleeping
Yet still a greatness,
A presence of the Whole,
Majestic Unity in a cosmic circle,
Guardians for Man,
Custodians of Time.





Callanish

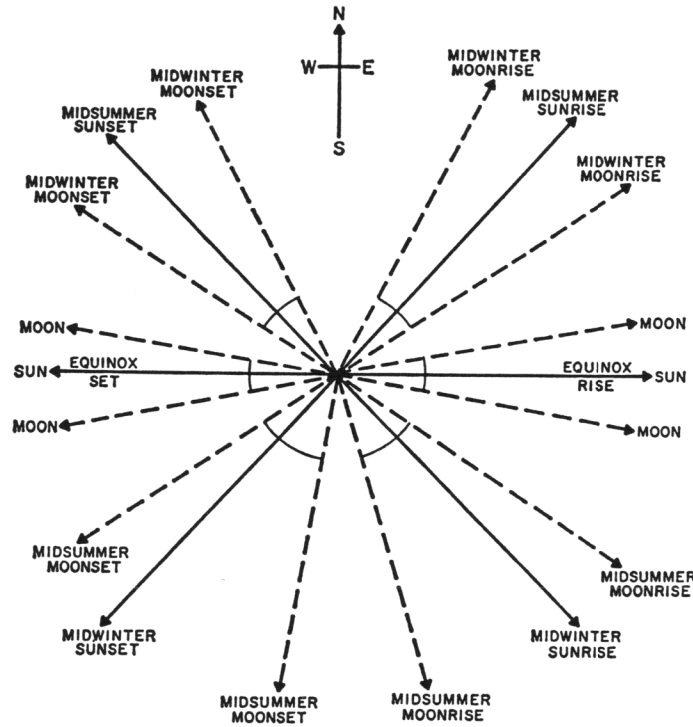

Fig. 3. The azimuthal direction of the rising and setting of the sun and moon at solstice and equinox for the latitude of Callanish.

13

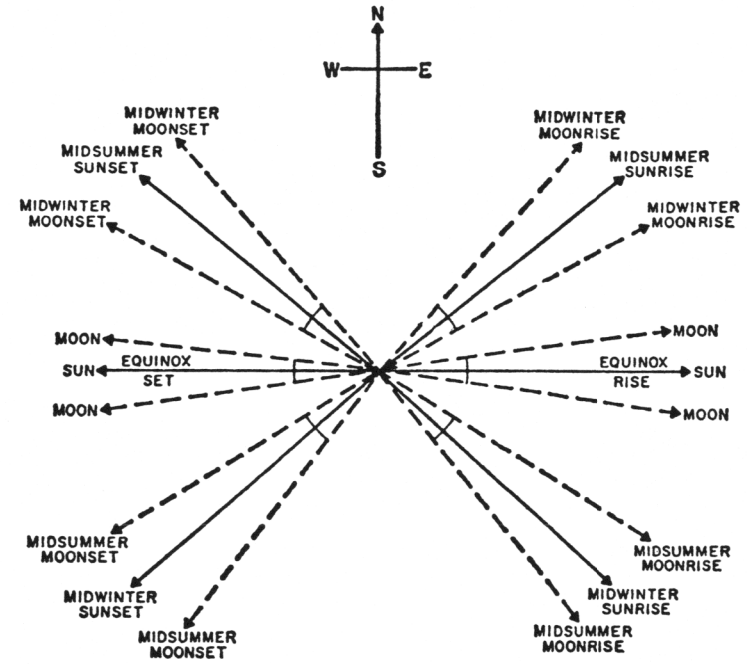

Fig. 1. The azimuthal direction of the rising and setting of the sun and moon at solstice and equinox for the latitude of Stonehenge.

14



The central circle at Callanish in a fresh snow-fall. Diameter of 11m, circle flattened on east central stone and five radiating rows.

15



PLATE 2. The trilithons and sarsen circle, July 1963, from the north.

16

Introduction

Towards an Etheric Architecture

The name of this world center is 'Bryn Myrddin'. This originates from the ancient legends of Merlin and King Arthur in their efforts to unite Great Britain as one land under peace and prosperity. The words 'Bryn Myrddin' are Welsh; Bryn is a hill sacred to the sky God Myrddin, a God of light, wind and thunder. Bryn Myrddin is also the name of the cave on a hillside in Wales where Merlin lived in quiet and solitude. The mountains behind the site are similar in terrain and forest to Wales.

The site is located on Peters mountain in West Virginia on a tract of land comprising 140 acres bordering the Jefferson National Forest, a wilderness area. A place of seclusion in nature. Peters mountain runs parallel to Potts mountain, with 'a valley that time forgot' in between. The sun and moon rise dramatically over Potts mountain. At a latitude of 37 degrees, this is the same latitude of Mesa Verde, home of the Anasazi Indians who marked astronomical positions with their buildings. The longitude of 81 degrees is close to that of Machu Pichu in Peru where the rising of the sun at certain times of year was marked. Eighty-one degrees also cuts the eastern edge of the North American continent and the western edge of the South American continent to link both hemispheres. The waters on the eastern side flow into the Atlantic and the waters on the western side flow into the Gulf of Mexico. The angle, Southwest, of Peters mountain aligns with the summer solstice sunrise. Large astronomical towers will be placed along the mountain's ridge to mark this celestial event. Peters mountain is part of the Appalachian mountains, one of the most geologically stable mountain ranges on the planet.

Due to the location of the site on a mountain facing east, the emphasis is on observing the sunrise during the solstices and equinoxes. The primary axis on the winter solstice sunrise aligns with the edge of a ridge and symbolizes man's rebirth every winter as the days begin to get longer. Sunlight shines on a narrow path of water; fire and water facing the sunrise, on the winter solstice.

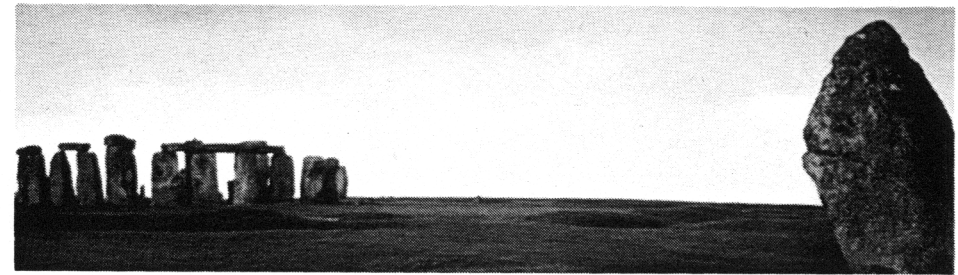

17

The summer solstice and vernal and autumn equinox are marked by pathways with the sun shining between concrete buttresses rising above the front retaining wall. Concrete columns just inside the front retaining wall, mark the sweep of the rising moon across the eastern horizon during its 18.6 year lunar cycle. Rooms for solitude, inside the earth behind a massive concrete retaining wall, welcome the light of the rising sun on the solstices and equinoxes. Notches on top of the rear retaining wall mark the sunset. Windows of stained glass in the retaining wall mark the passage of months between summer solstice and winter solstice in a spectrum of different colors.

In an on going exploration of architectural from generated by astronomy, two temples are built. A circular 'Plaza of the Sun' of marble and granite paving stones, cuts into the earth with a square surrounding a circular fountain. The circle; symbol of unity, harmony and celestial spheres. The square; symbol of earth, stability, and the four directions. The square 'Temple of the Moon', a foundation of strength with four large poured-in-place concrete columns and steel trussed roof rising to an infinite point in the heavens. The four columns represent earth, air, fire and water. Between the four columns, a sacred circle for gathering and celebration, dancing under the stars. Inside the columns, seats for solitude and meditation, with pre-cast concrete capitals forming an open cross to allow viewing of the moon and stars overhead. During the course of the year, the rising sun and moon move between two opposite columns touching their edges to mark the winter and summer solstice. Viewed from the 'Plaza of the Sun', the pyramidal truss of the 'Temple of the Moon' seems to float above the landscape.

Finally, 'Towards an Etheric Architecture', is the process of Architecture and form giving towards which I aspire. The ancients regarded the ether as the invisible substance filling all space in the heavens and comprising the planets and stars. An Architecture of making the invisible visible.

Site



View Towards The Sunrise

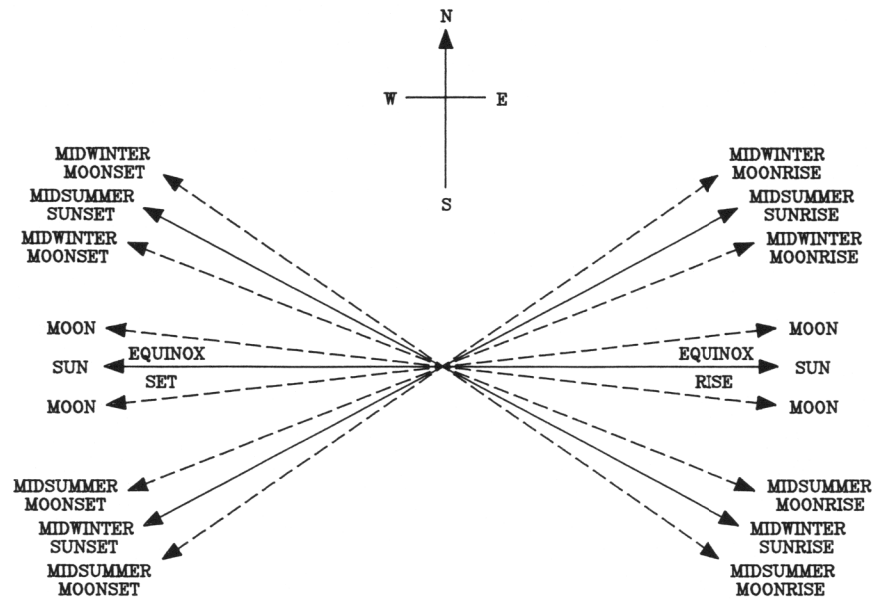

The azimuthal direction of the rising and setting of the sun and moon at solstice and equinox for the latitude of Bryn Myrrdin due to the 23.5 degree tilt of the earth's axis and the procession of the seasons.

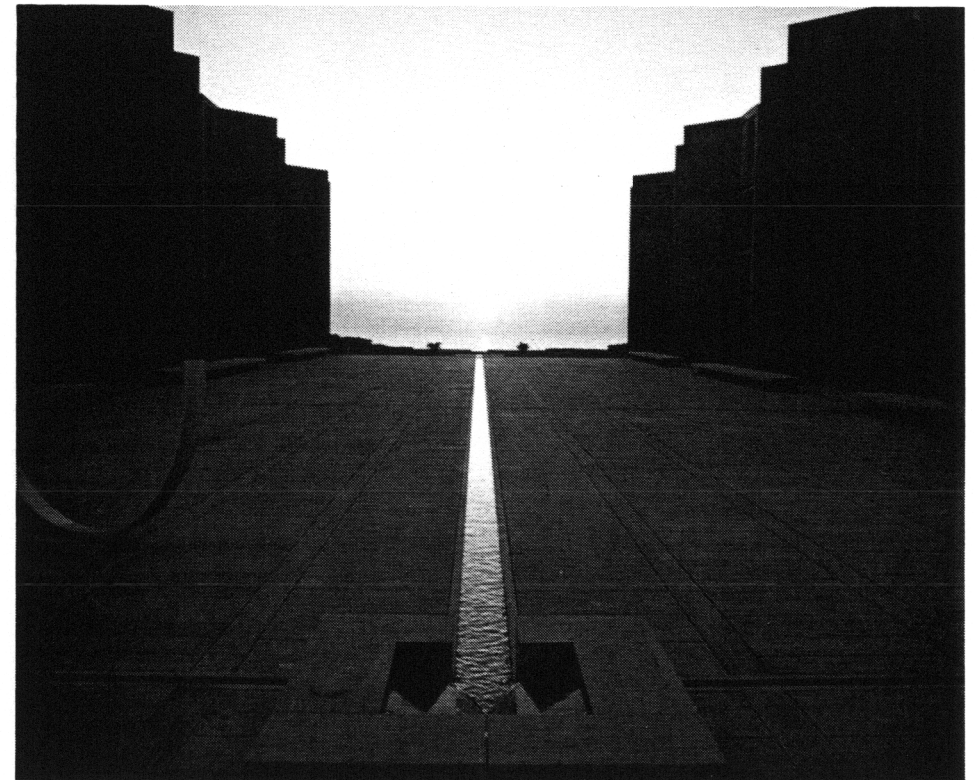

Salk Institute Plaza Equinox Sunset

Though my soul may set in darkness
 It will rise in perfect light;
 I have loved the stars too fondly
 To be fearful of the night.

An old astronomer
 to his pupil, Galileo

Night comes, an angel stands
 Measuring out the time of stars,
 Still are the winds,
 And still the hours.

from the poem 'Nocturne'
 by Kathleen Raine

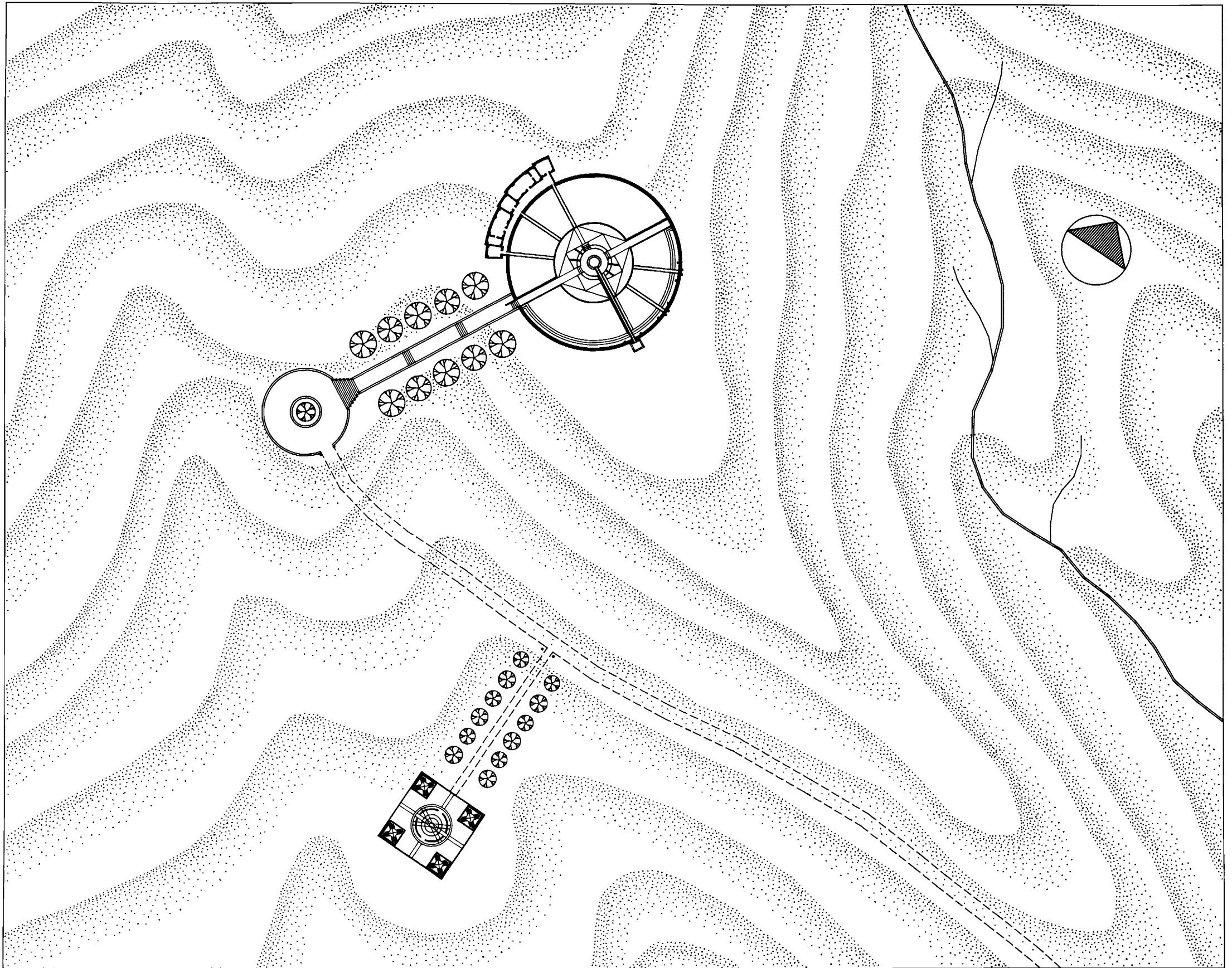

Site Plan

Scale: 1 = 120'

Plaza of the Sun

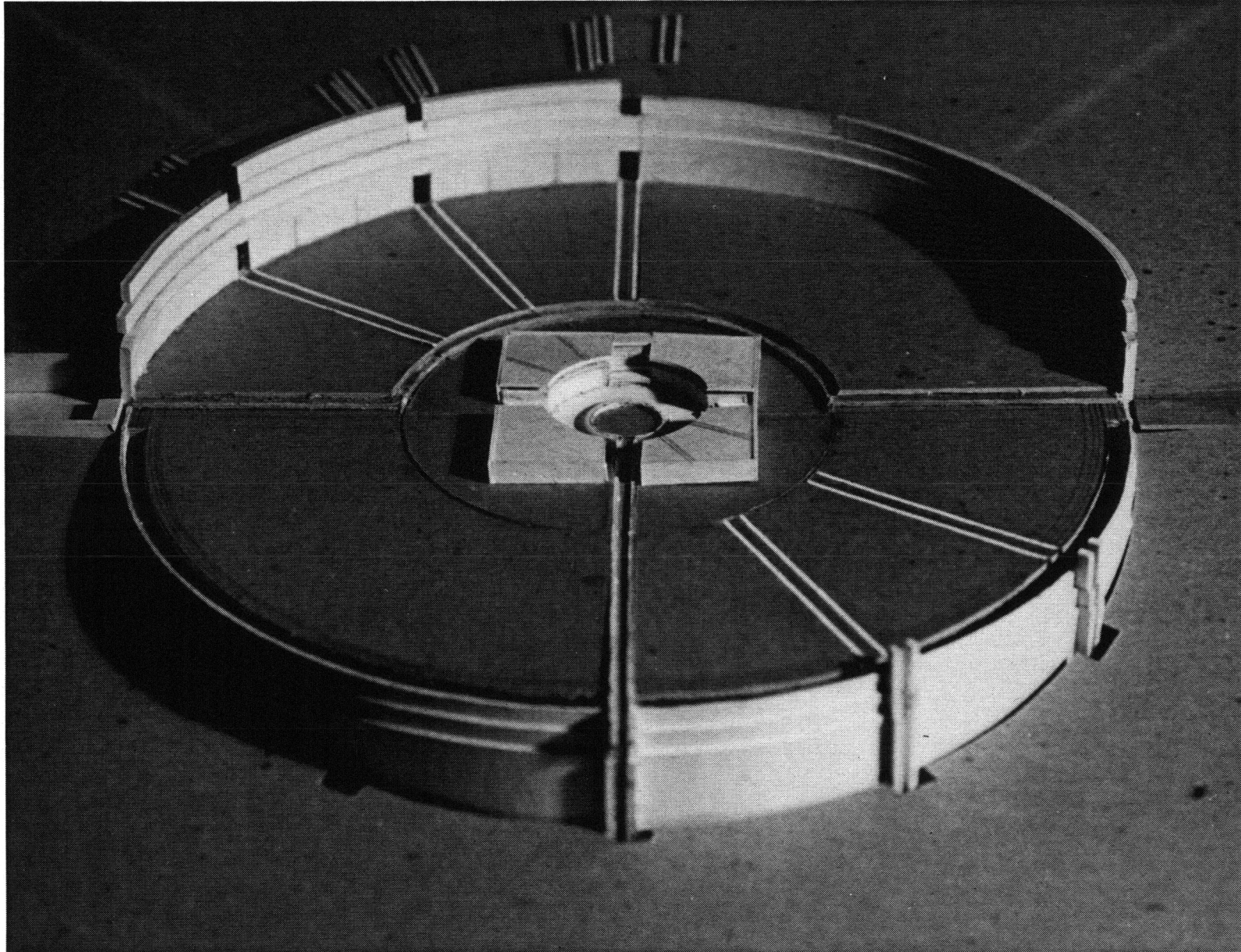

Plaza of the Sun

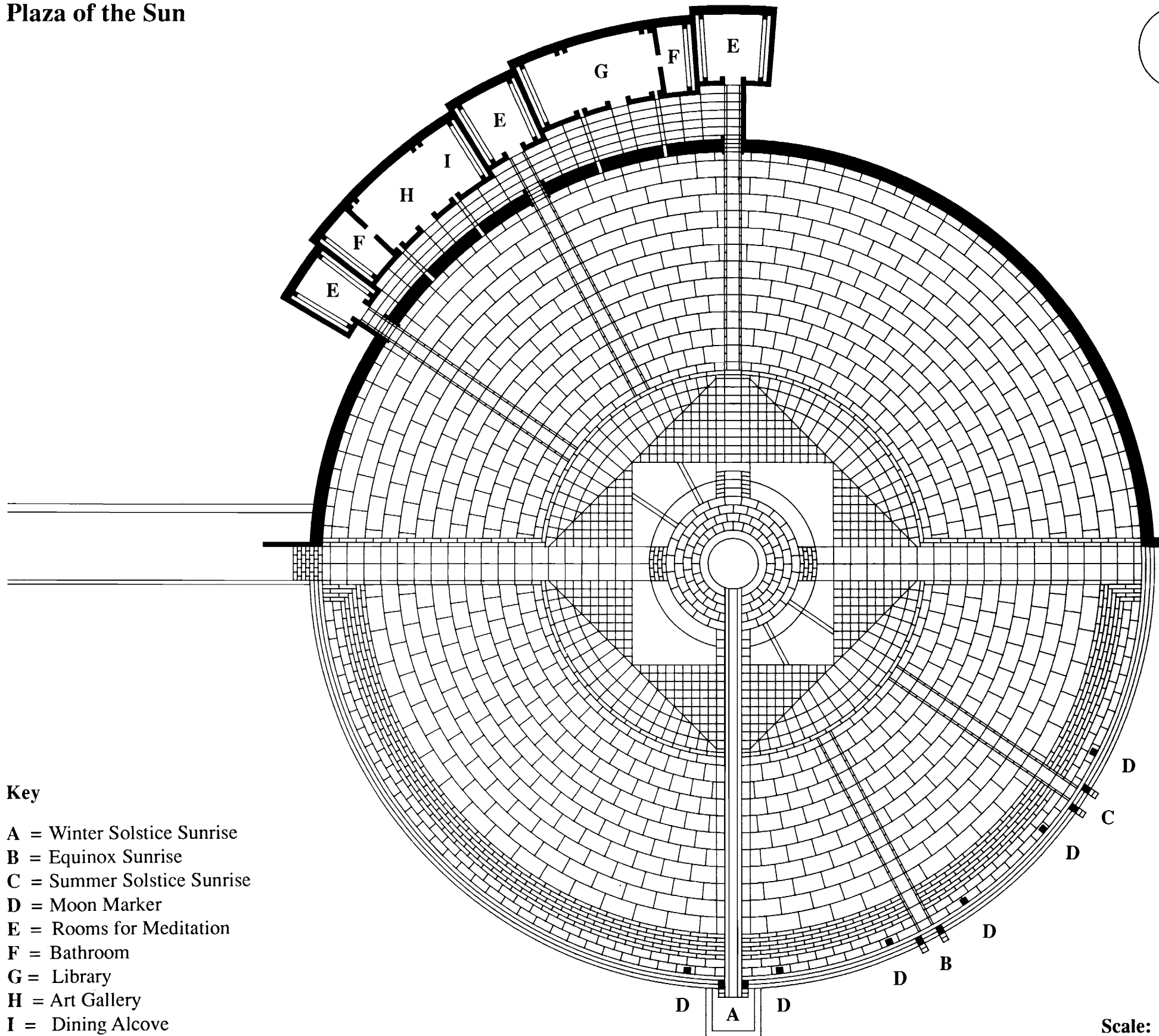
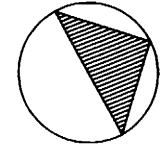

Key

- A = Winter Solstice Sunrise
- B = Equinox Sunrise
- C = Summer Solstice Sunrise
- D = Moon Marker
- E = Rooms for Meditation
- F = Bathroom
- G = Library
- H = Art Gallery
- I = Dining Alcove

Scale: 1 = 28'

Quiet waterfall whispers
To a primordial forest,
Near the Autumn wild,
The Mountain drifts.

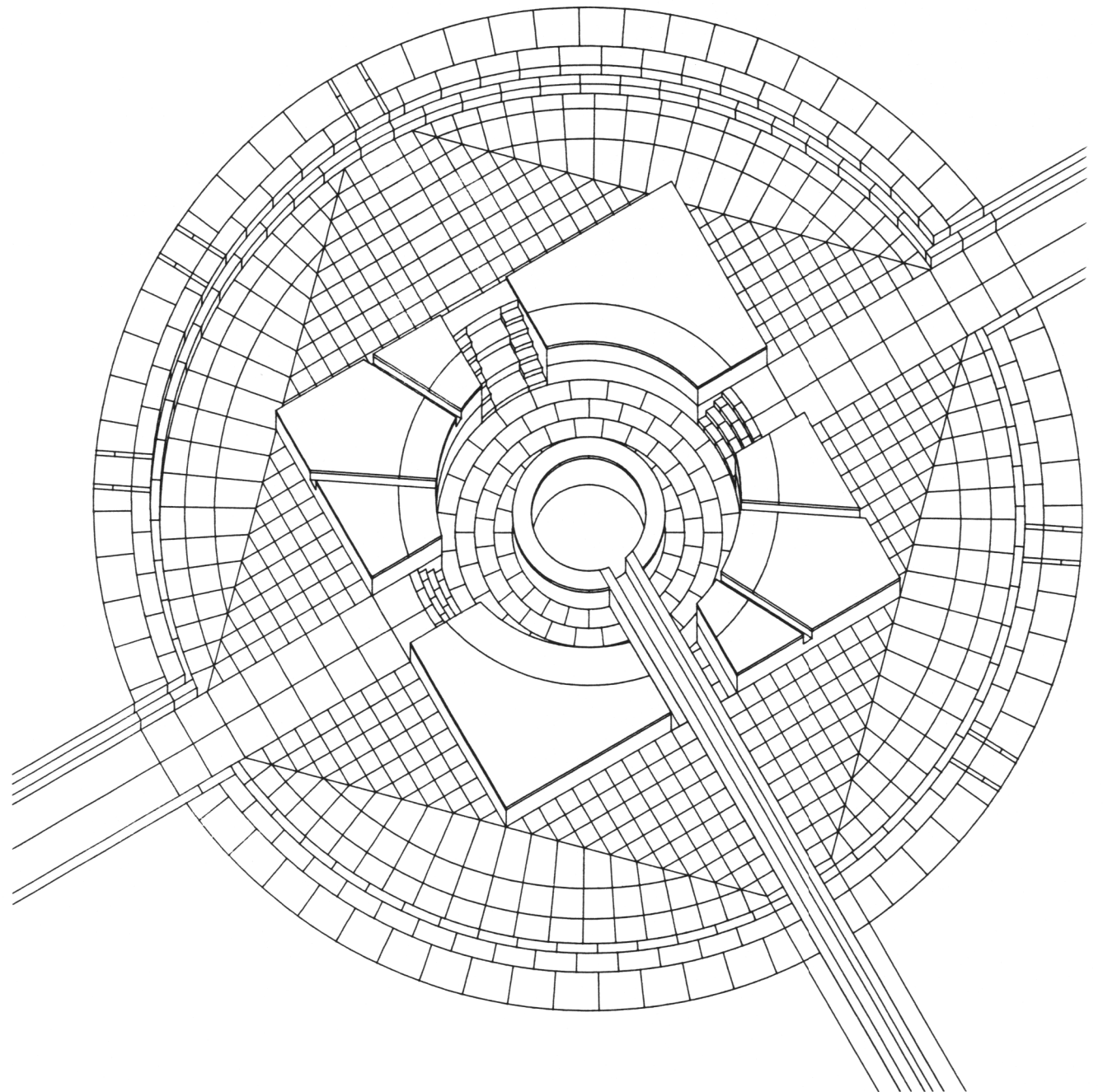
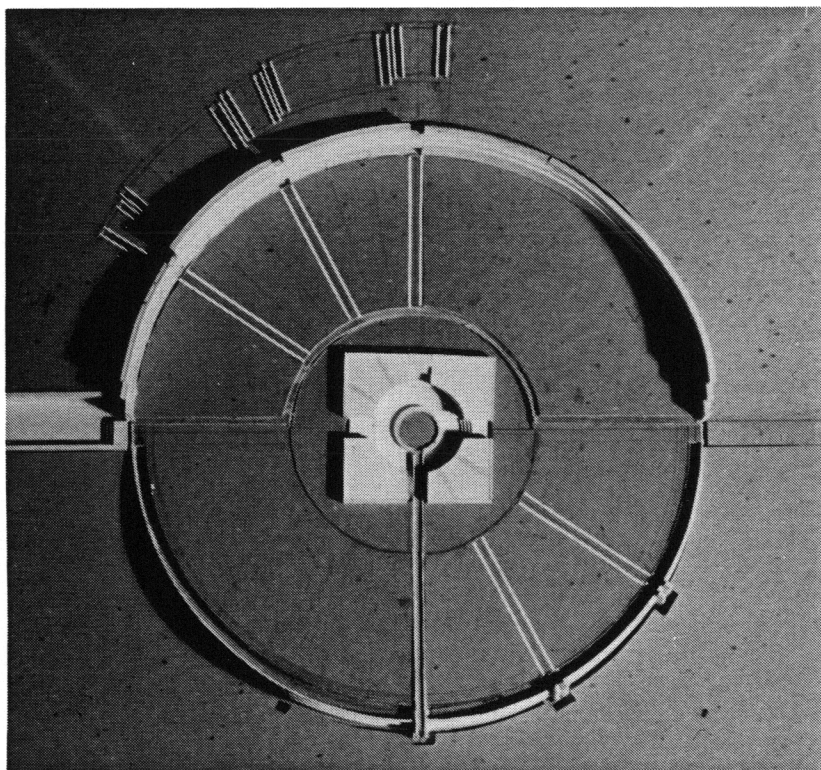

Fountain with Path of Water Towards Winter Solstice Sunrise

View From Edge of Plaza of the Sun

(SIMILAR TO VIEW AT SUMMER SOLSTICE AND EQUINOX)

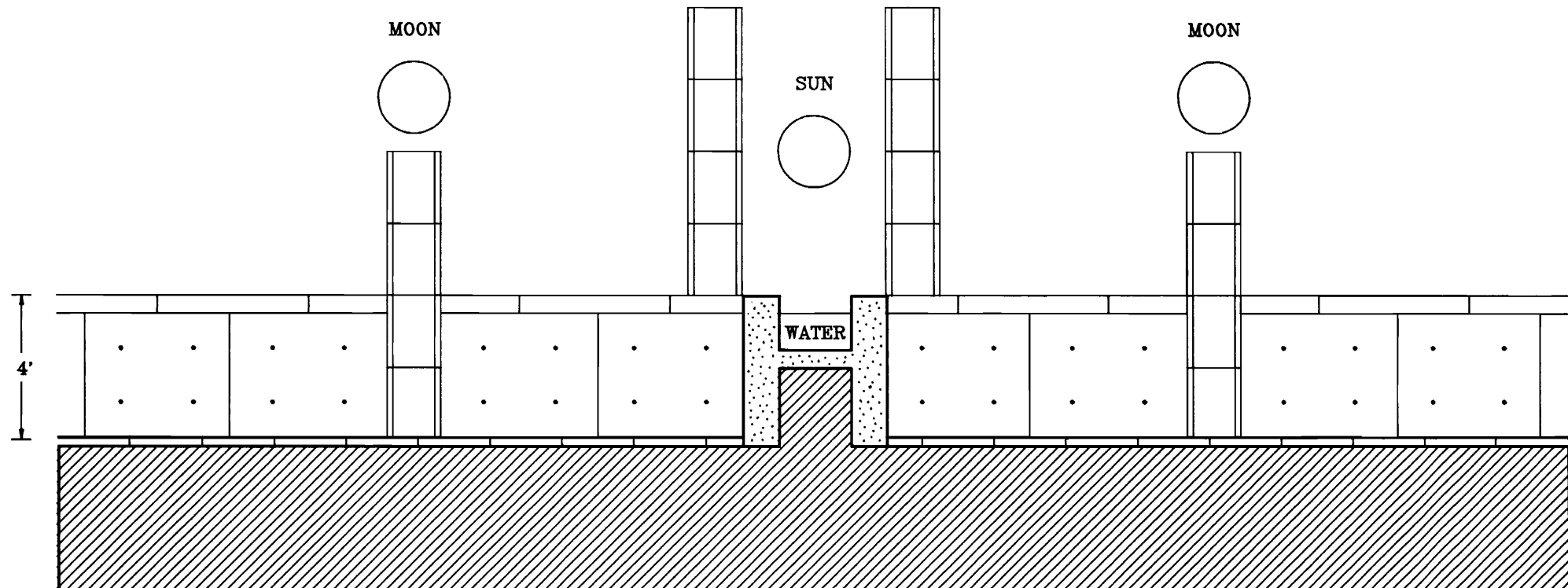

MIDSUMMER MOONRISE
AT THE SOUTHERN
EXTREME OF THE
MINOR STANDSTILL

WINTER SOLSTICE
SUNRISE

MIDSUMMER MOONRISE
AT THE SOUTHERN
EXTREME OF THE
MAJOR STANDSTILL

THE MOVEMENTS OF THE MOON

The swings of moonrise and moonset across parts of the eastern and western horizon are similar to those of the sun, but occur monthly, not annually, with about thirteen swings a year. But, due to the tilt of the moon's orbit, the length of the swings varies over the months. A complete cycle, from "major standstill" to "minor standstill" and back again, is completed in 18.61 years. (The moon never "stands still" - the term refers to the repetition of a similar pattern of movements over several consecutive months.)

Gerald Ponting and Margaret Ponting, *New Light on the Stones of Callanish*, p. 45.

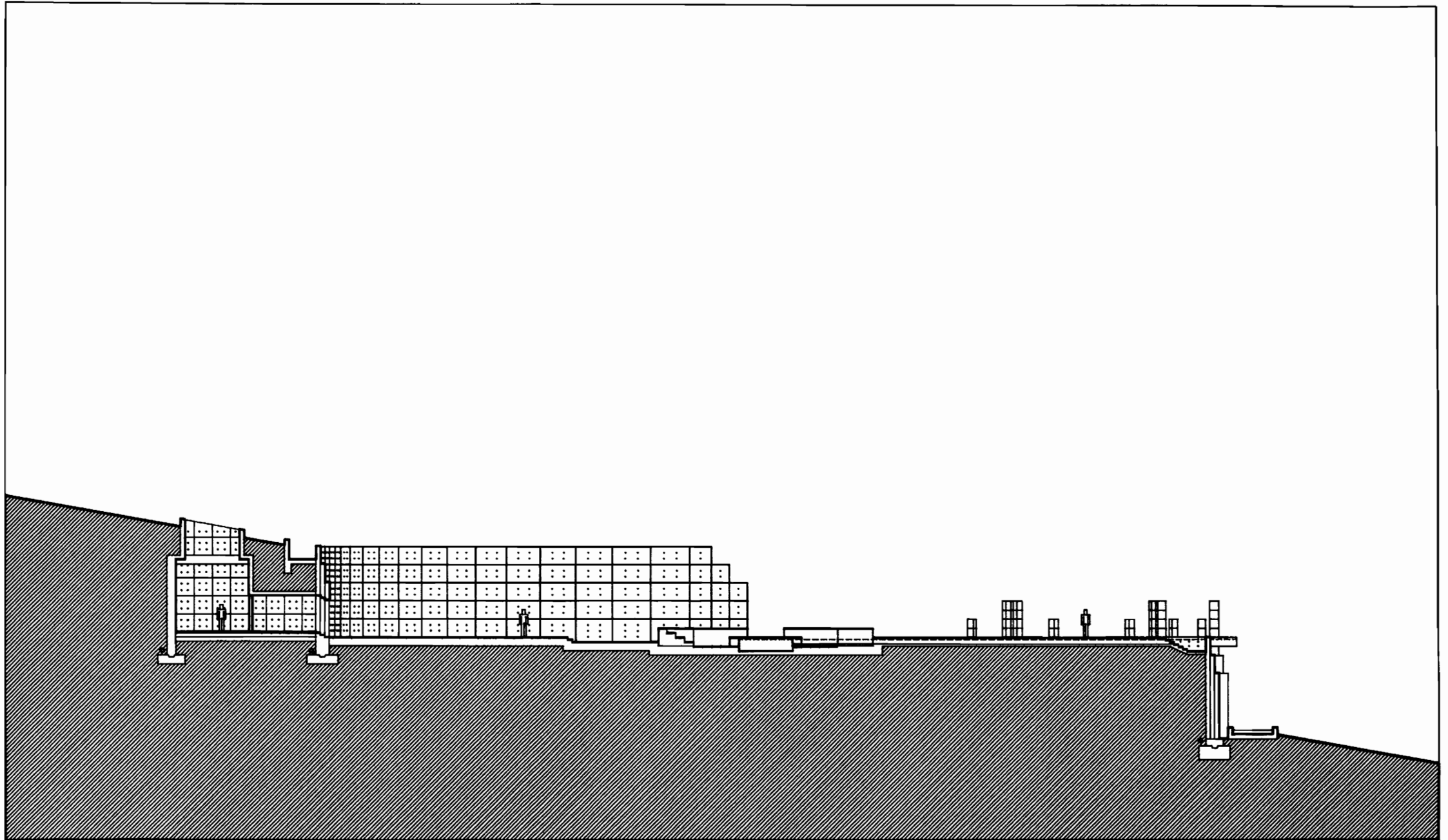

Section Through Winter Solstice Sunrise Axis

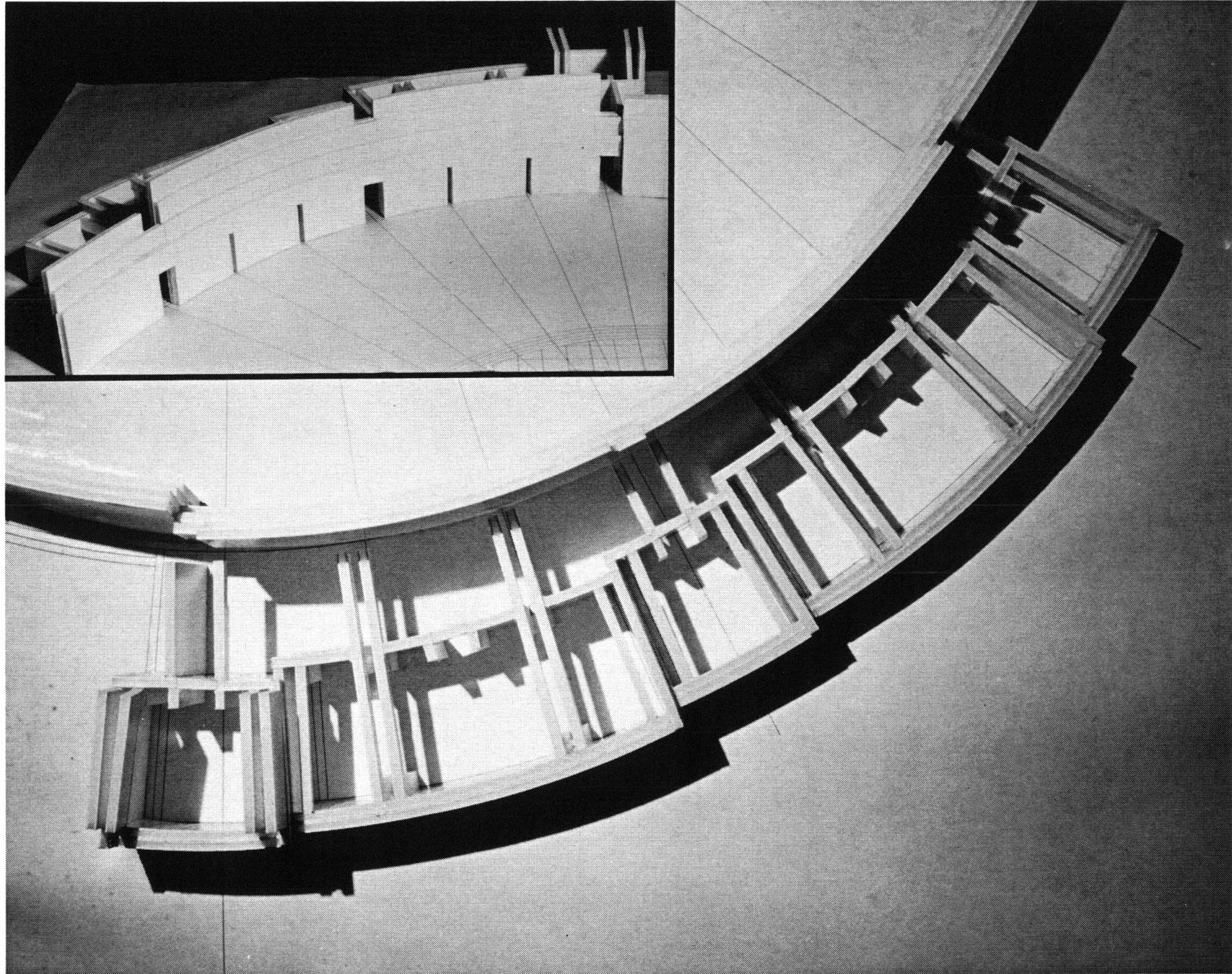

Rooms in the Retaining Wall

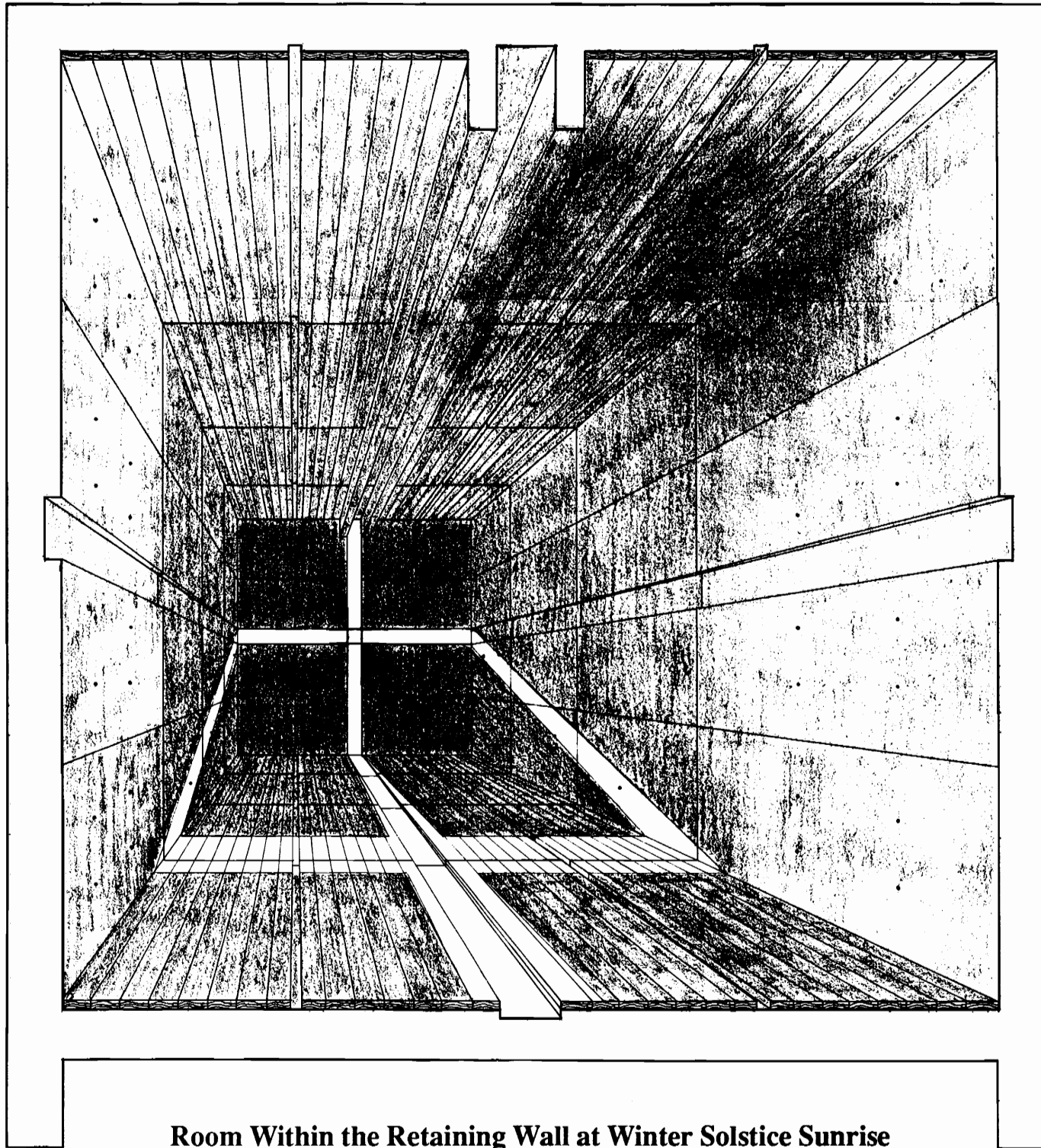

Room Within the Retaining Wall at Winter Solstice Sunrise

Love's Longing
A bright red rose
The Beloved's pain. . .
A Timeless Journey.

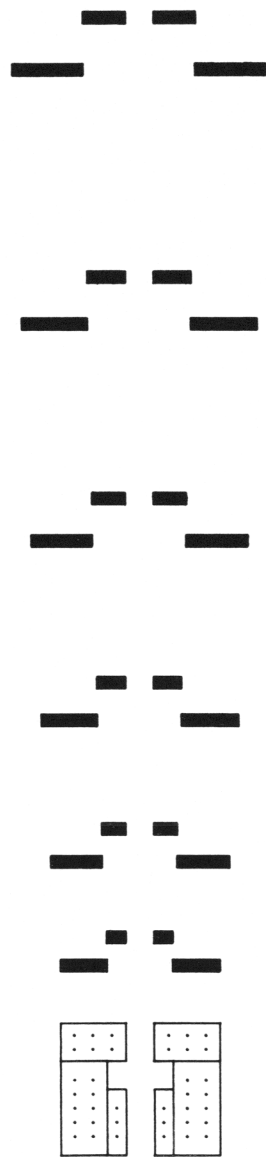

Floating petals
 Cold crystals
 Water rushing smoothly. . .
 Over the One.

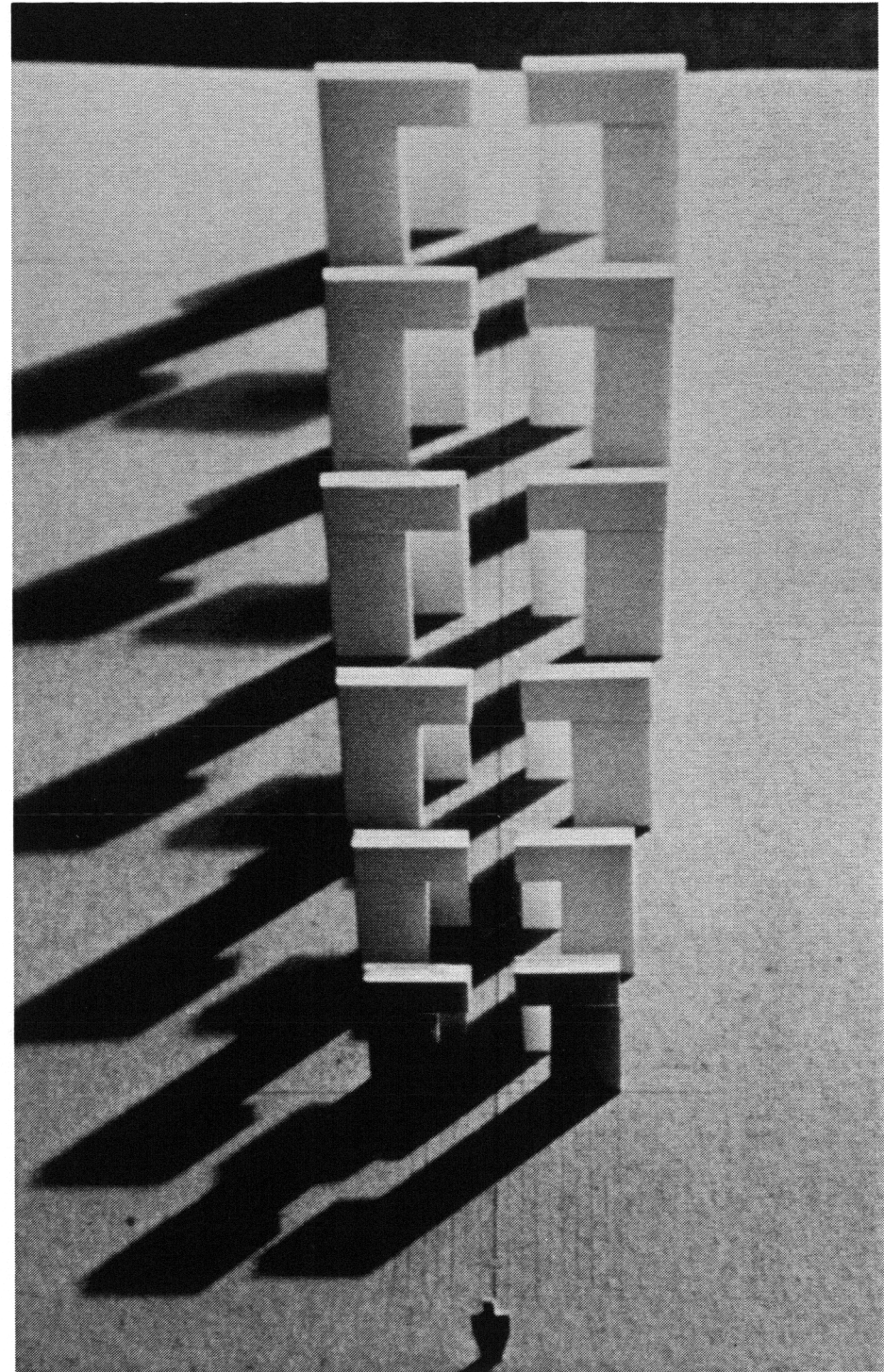

Summer Solstice Sunrise Alignment

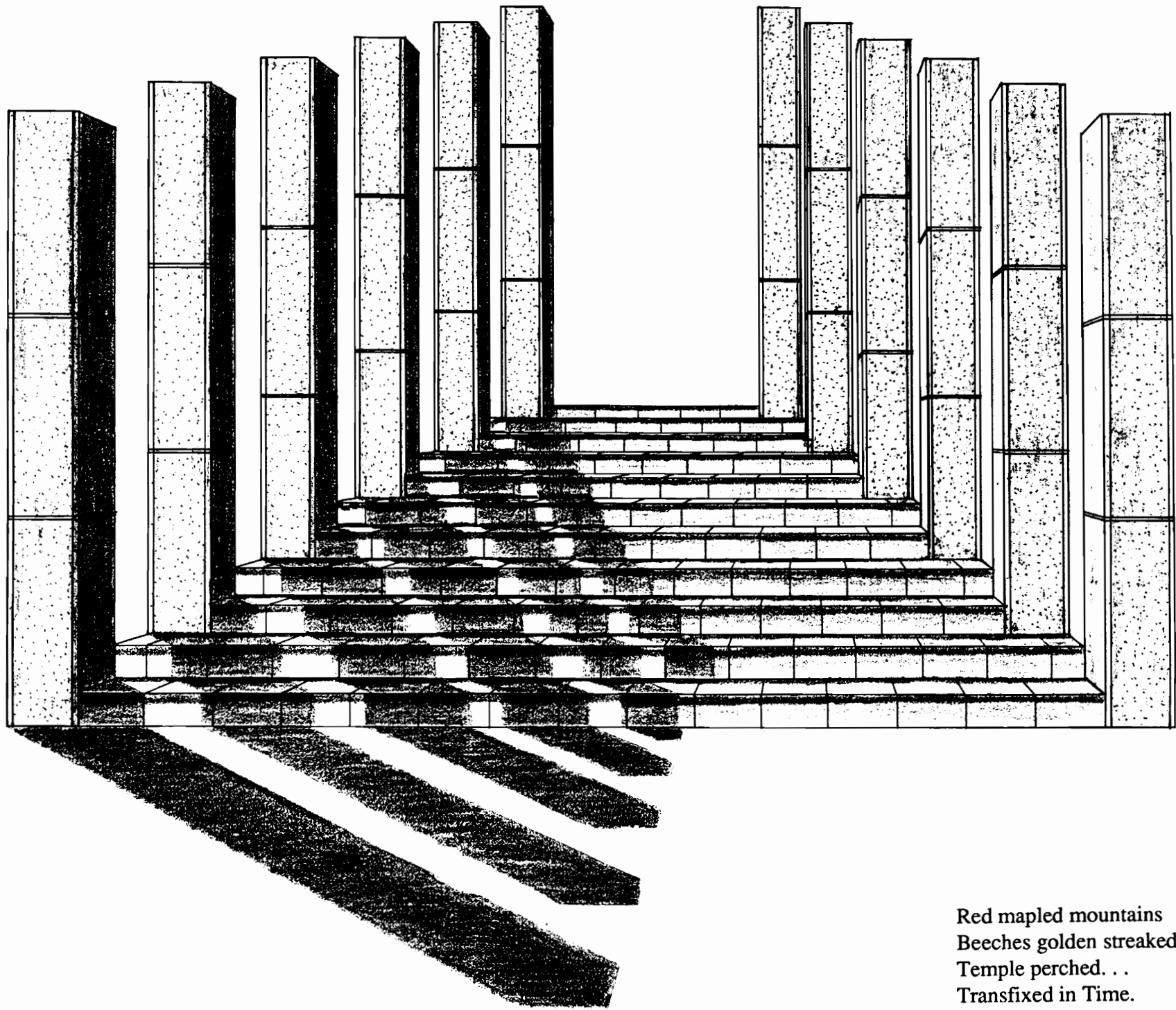

Red mapled mountains
Beeches golden streaked
Temple perched. . .
Transfixed in Time.

Entrance to the Plaza of the Sun

Temple of the Moon

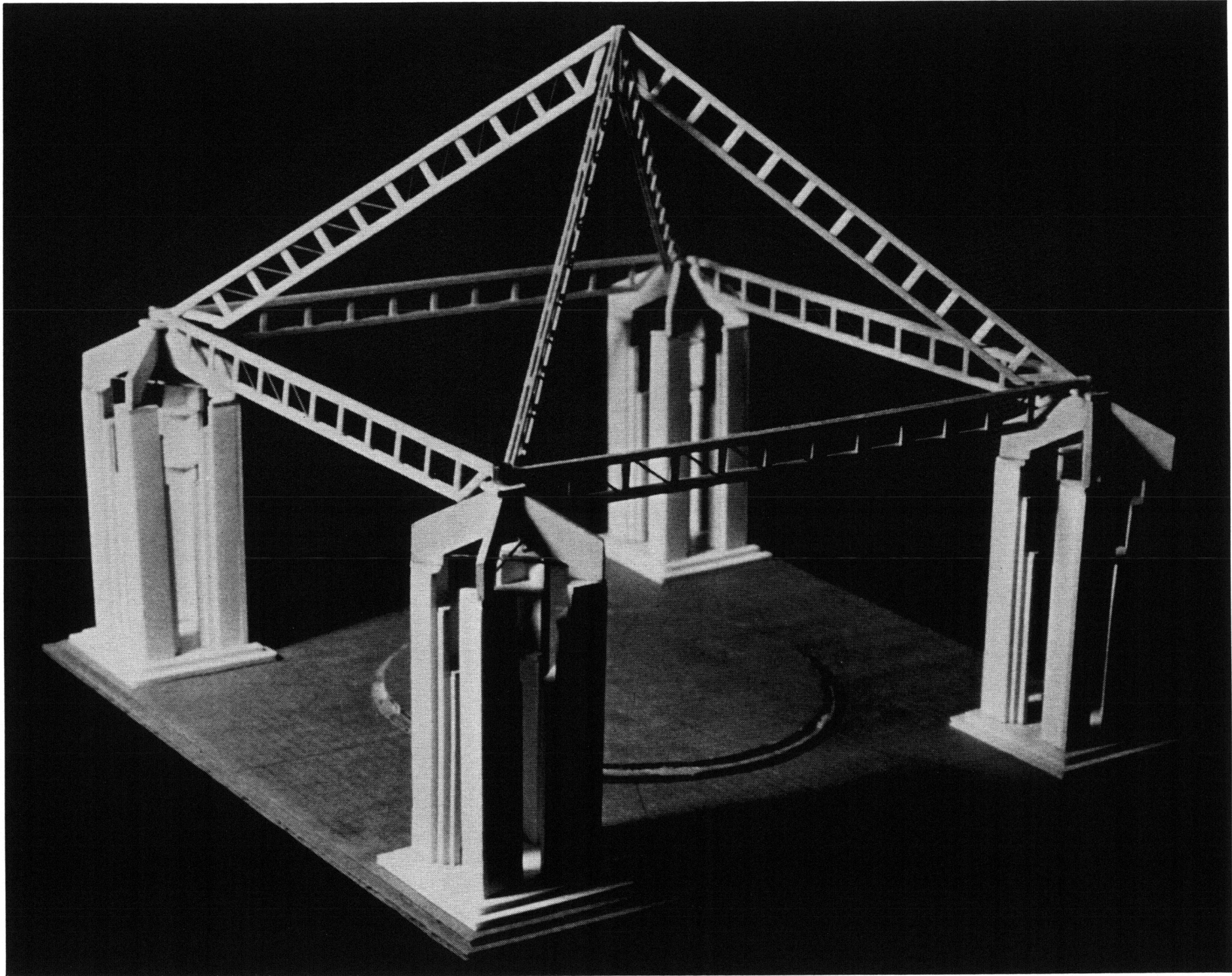

Temple of the Moon

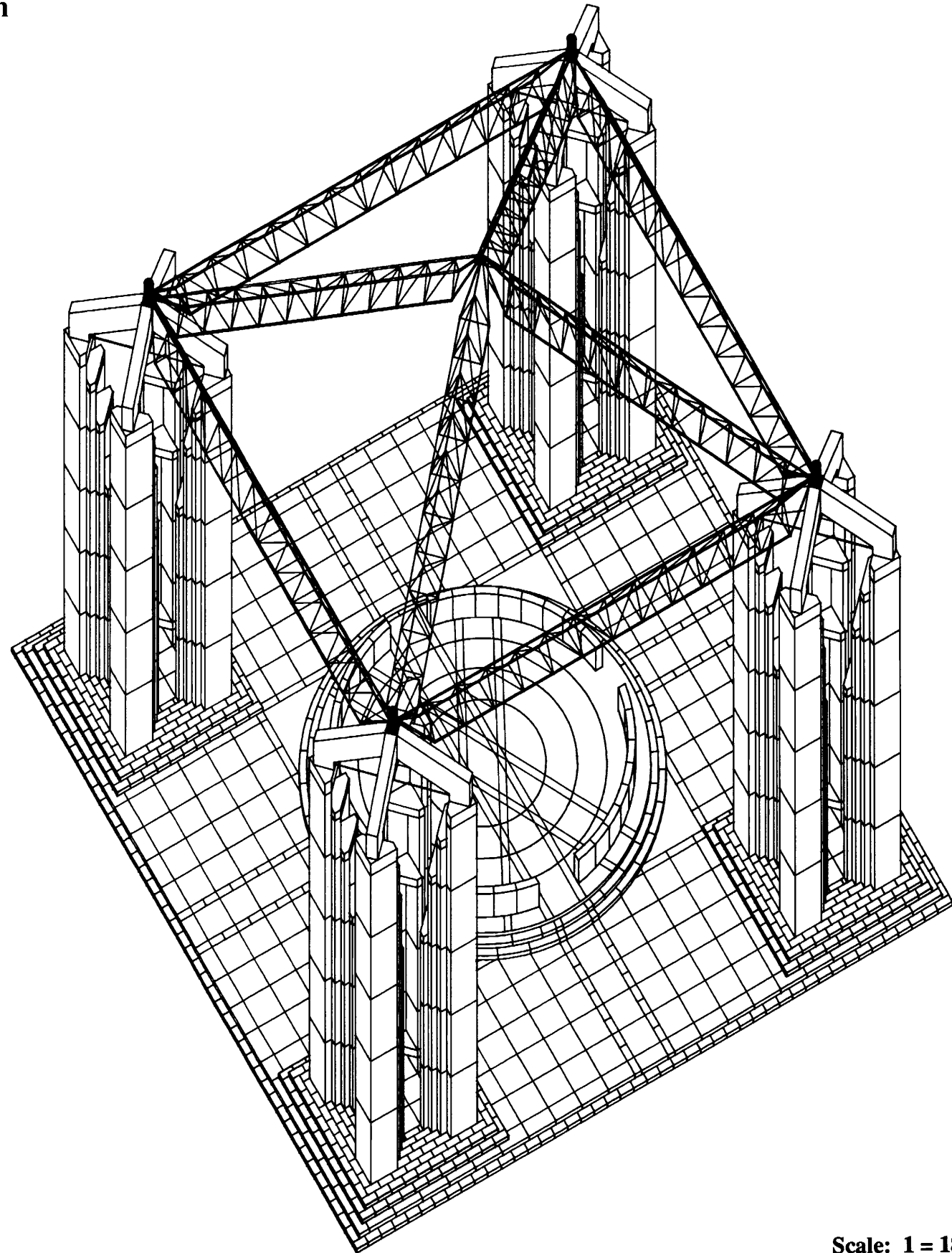

Above the Temple,
Wind swept gnarled pines,
Hawks soaring on
Eternal tones of Time.

Scale: 1 = 18'

Study Models

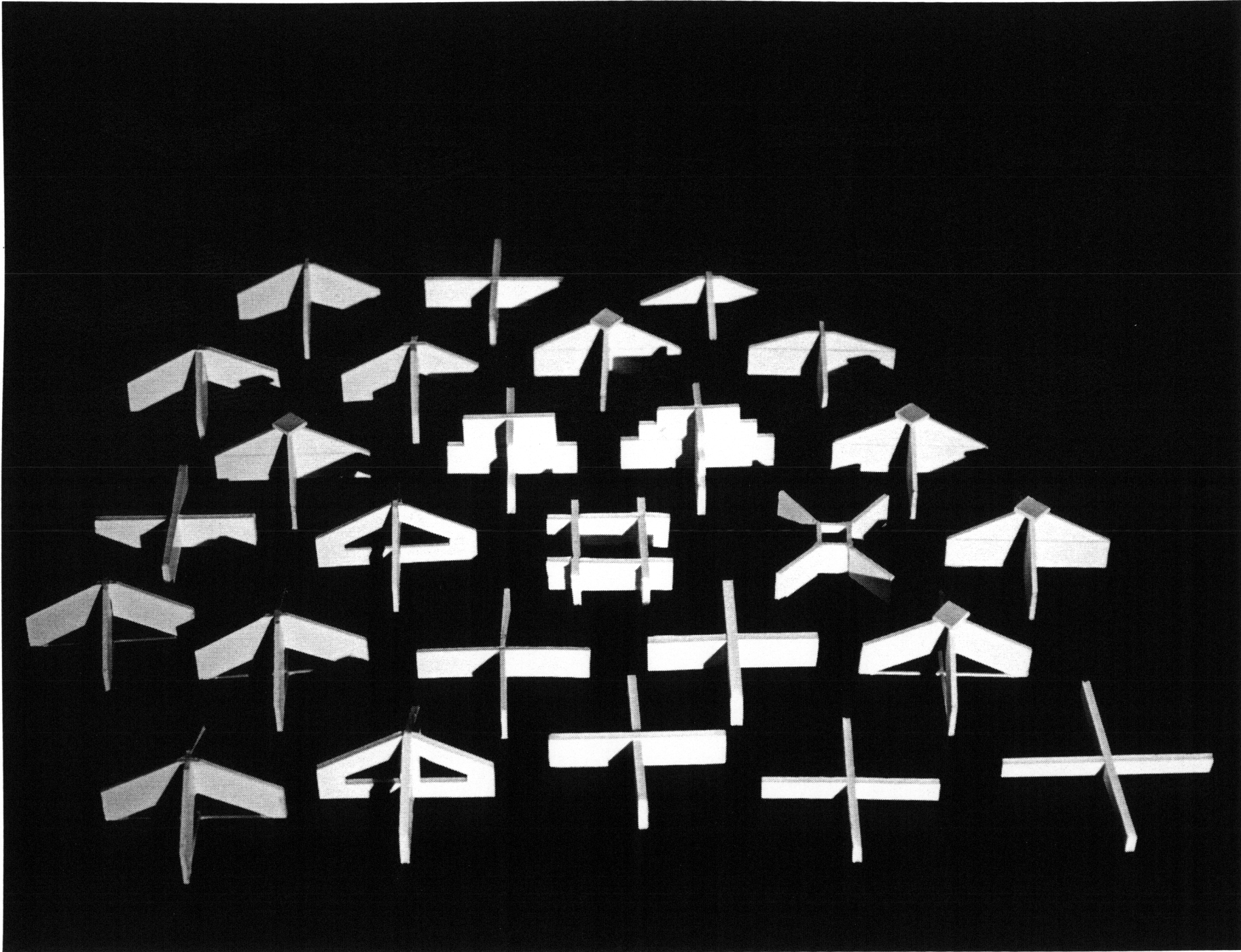

Column Capitals

The Column
A Place for Meditation

To Long
To Dare
To Know
To Keep Silent

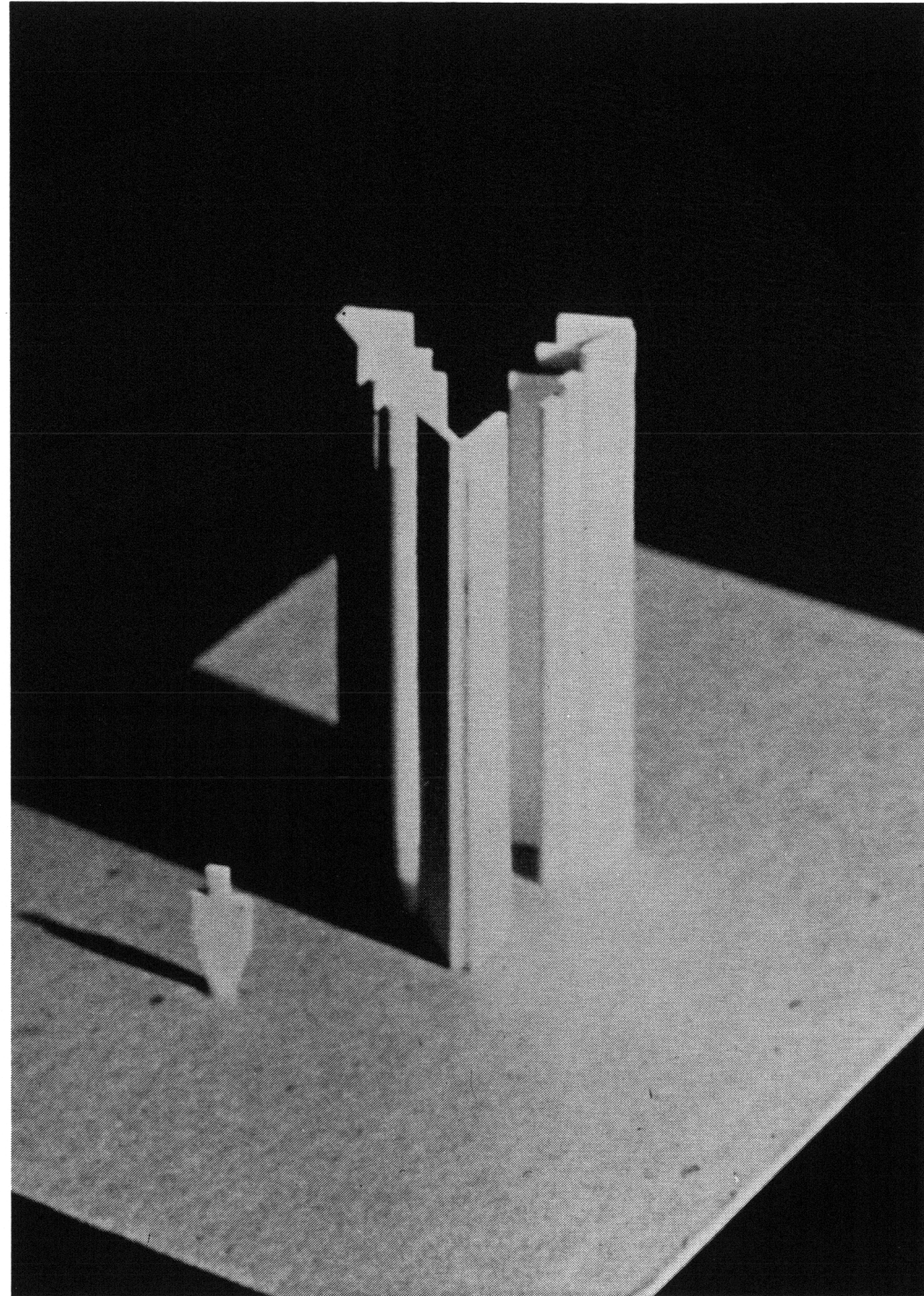
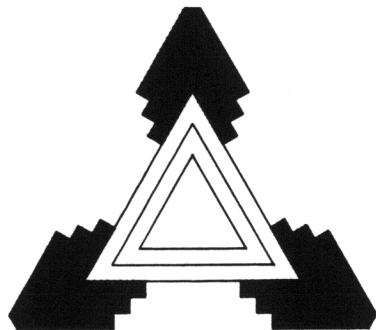

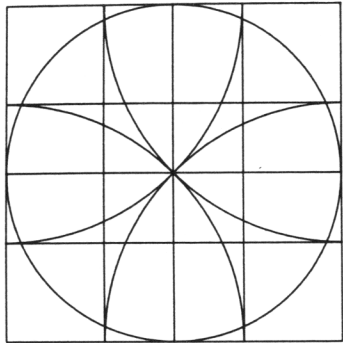

Freemason Symbol, Tons Brunes
The Secrets of Ancient Geometry,
Rhodos Publishers, Copenhagen

All material in nature, the mountains and the streams and the air and we, are made of Light which has been spent, and this crumpled mass called material casts a shadow, and the shadow belongs to Light.

Louis Kahn

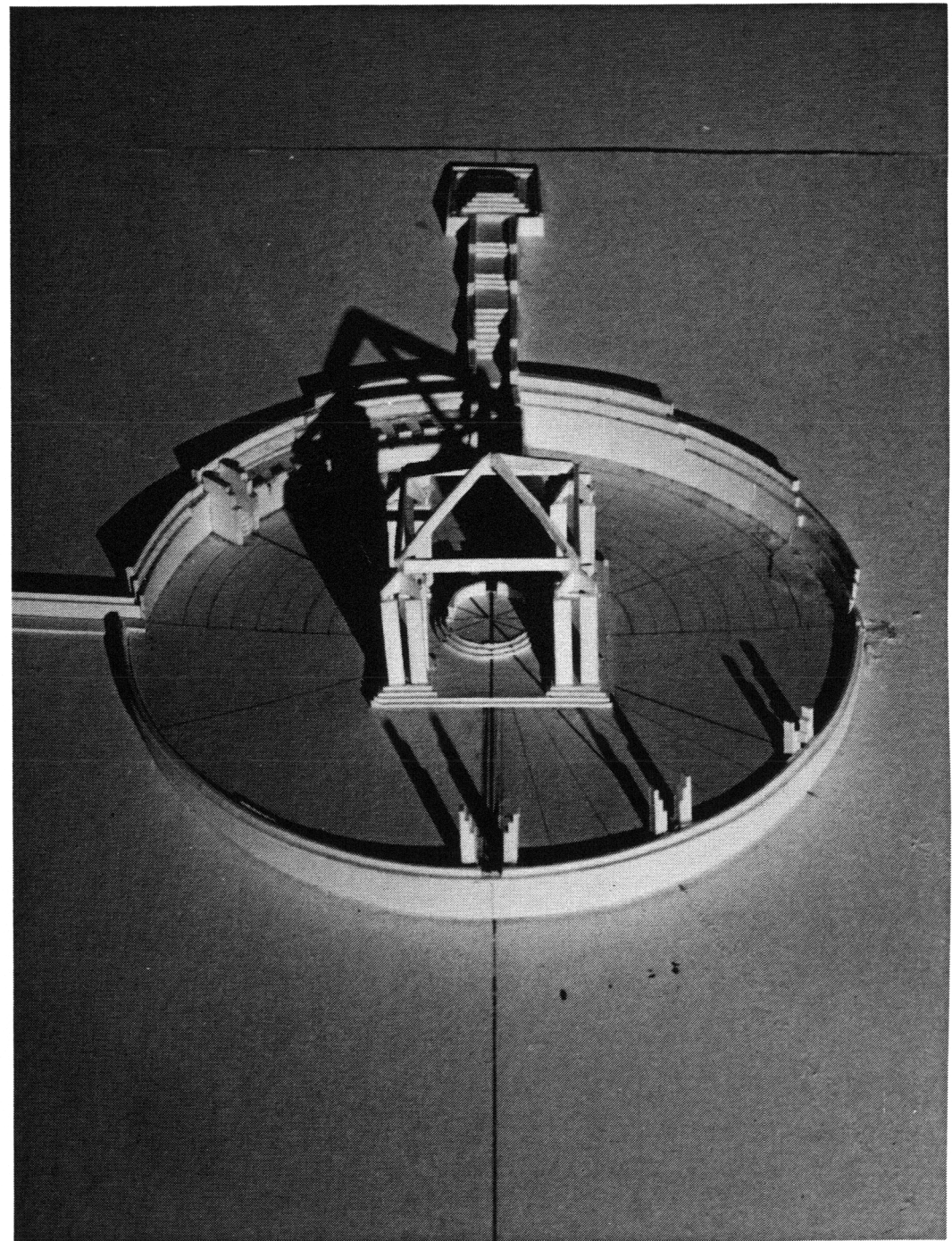

Wall Study

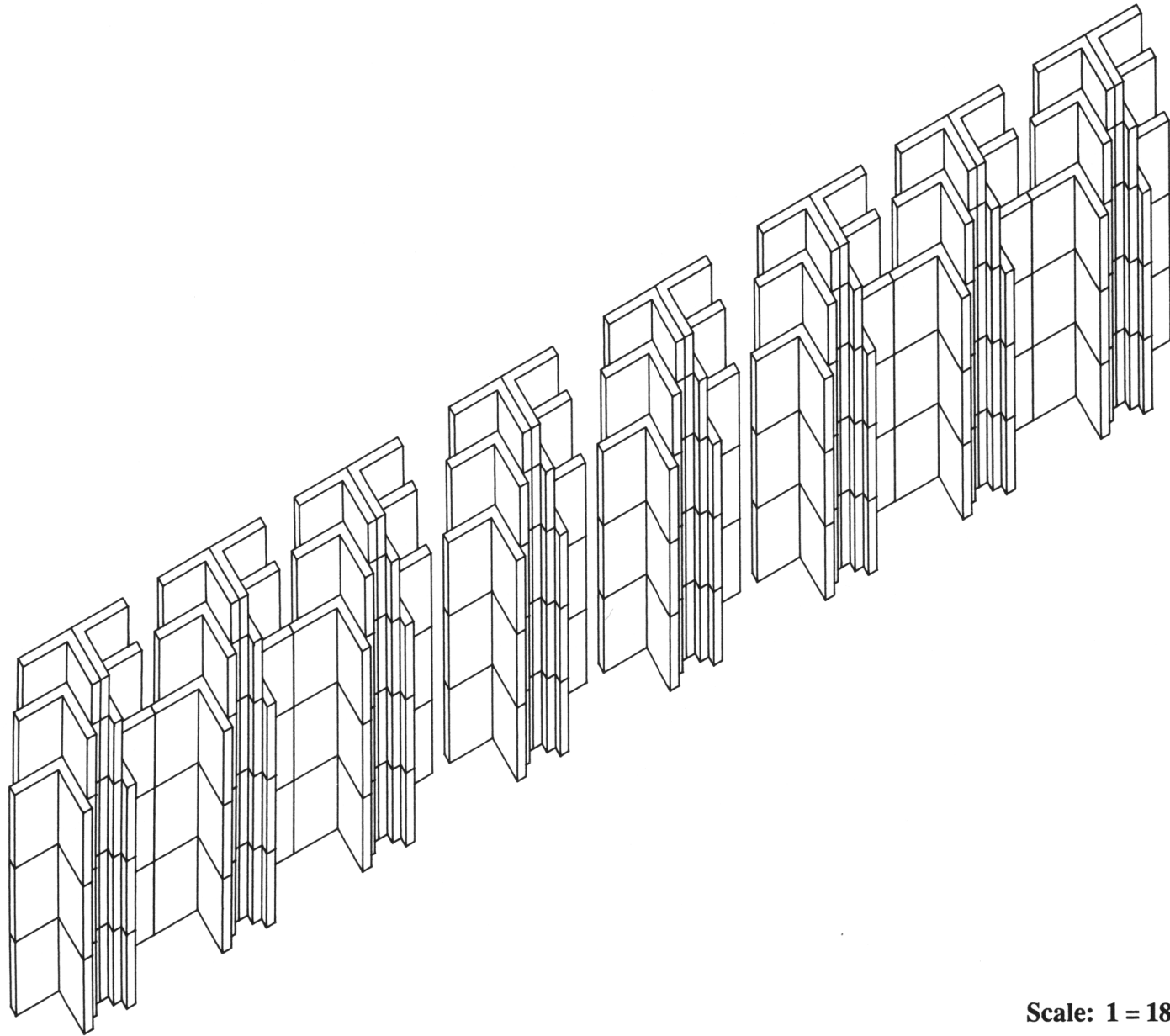

Scale: 1 = 18'

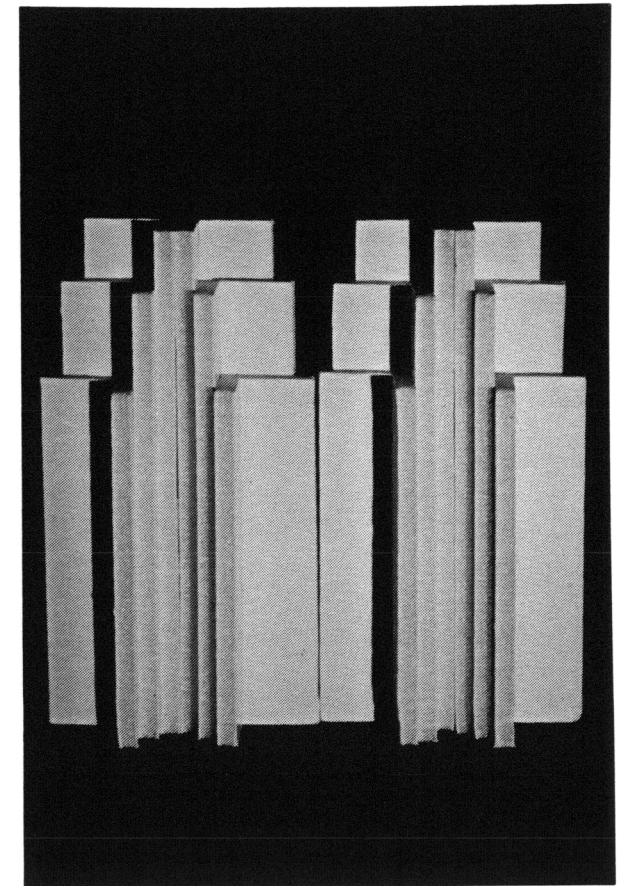

Man, Man, your time is sand,
And all your ways are known to me.

Nostrodamus

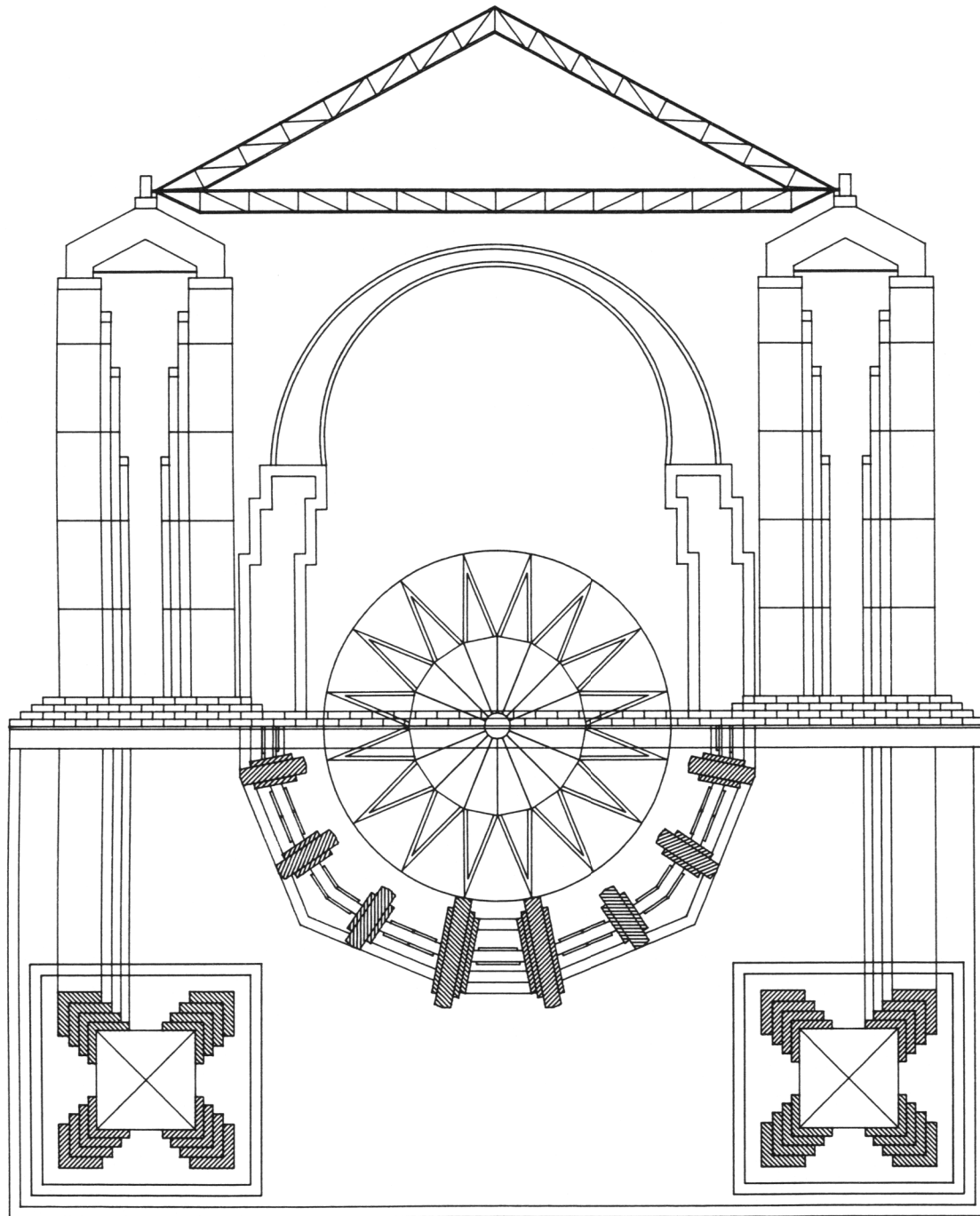

Dome Study

Scale: 1 = 16'

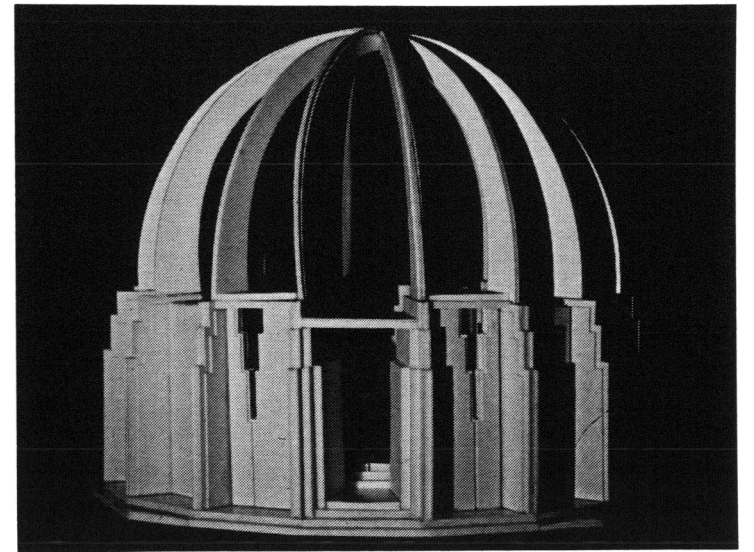

The moon is up and yet it is not night
The sun as yet divides the day with her.

J.M.W. Turner

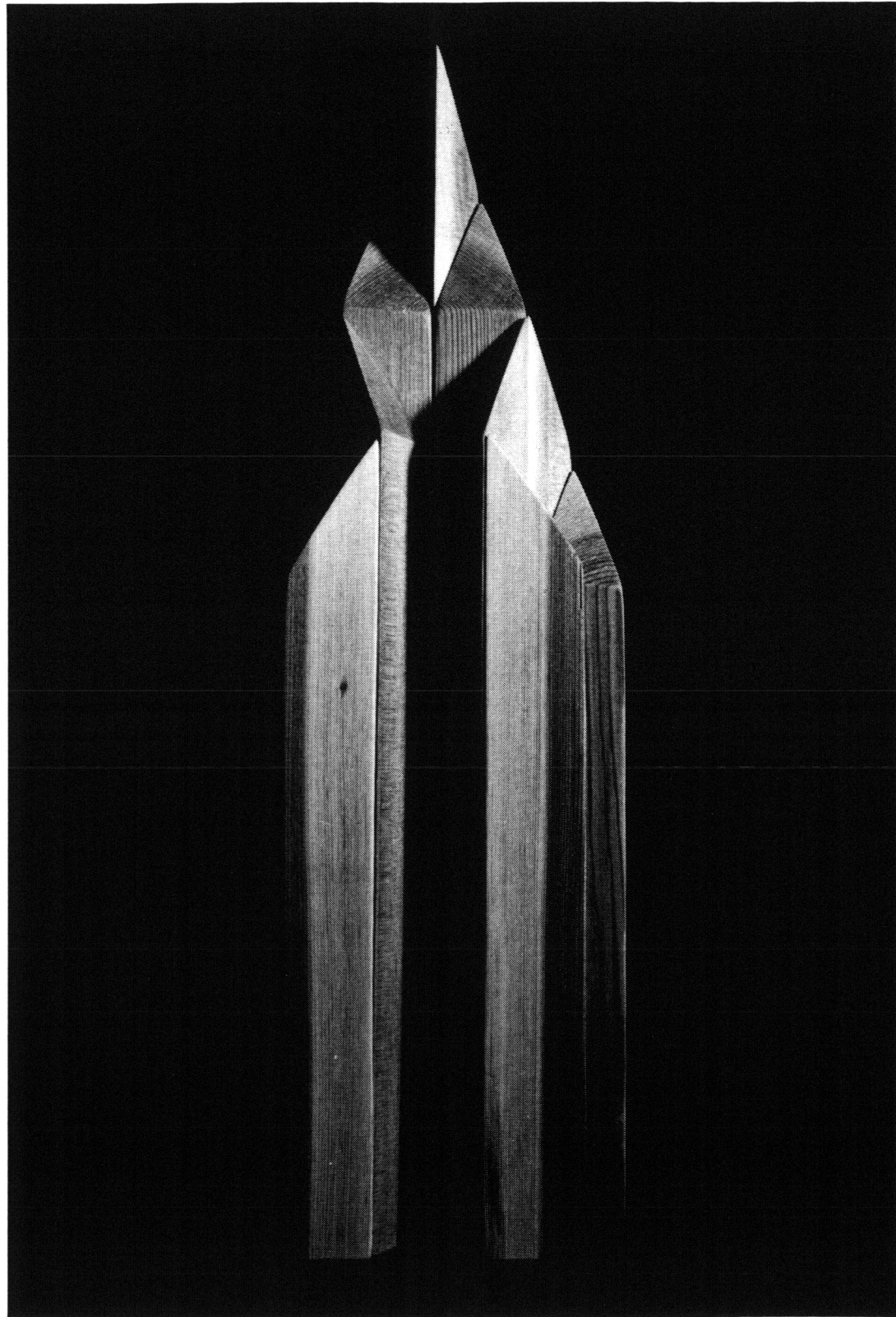

Out of the One, Many. . .
Asymmetry through Symmetry.
Patterns of Refraction Compose
The Universe.

List of Illustrations

All other photographs, drawings, sculpture and poetry © by the author.

1. Gyorgy Doczi, *The Power of Limits*, Diagram of a Daisy, p. 1.
2. Peter Tompkins, *Secrets of the Great Pyramid*, Grand Gallery, p. 152.
3. Kenneth Brecher and Michael Feirtag, Editors, *Astronomy of the Ancients*, p. 22, from the Griffith Observatory.
4. Gerald S. Hawkins, *Stonehenge Decoded*, plate 22.
5. Peter Tompkins, *Secrets of the Great Pyramid*, p. 148.
6. Michael Raeburn, *Outline of World Architecture*, Parthenon, p. 24.
7. *Astronomy of the Ancients*, fig. 31.
8. *Astronomy of the Ancients*, p. 191, photo by Robin Rector Krupp.
9. *Astronomy of the Ancients*, p. 220.
10. S. Gideon, *The Eternal Present, The Beginnings of Architecture*, plate 254, photo by S. Gideon.
11. *Astronomy of the Ancients*, p. 235.
12. John Lobell, *Between Silence and Light*, p. 27, photo J. L. de Cenival.
13. Gerald S. Hawkins, *Stonehenge Decoded*, fig. 3.
14. Gerald S. Hawkins, *Stonehenge Decoded*, fig. 1.
15. G. Ponting & M. Ponting, *New Light on the Stones of Callanish*, p. 24.
16. Gerald S. Hawkins, *Stonehenge Decoded*, plate 2.
17. Keith Critchlow, *Time Stands Still*, p. 72, photo by Rod Bull.
18. The American Institute of Architects, *A Universe Calendar*, Salk Institute Plaza, photo by Robert M. Haley, Jr., AIA.
19. *The Eternal Present*, plate 199, photo by S. Gideon.
20. Andreas Volwahren, *Living Architecture, Indian, Caurasi*, p. 163.
21. Robert Lawlor, *Sacred Geometry, Dancing Atoms*, p. 109, photo by Dr. Erwin Muller.

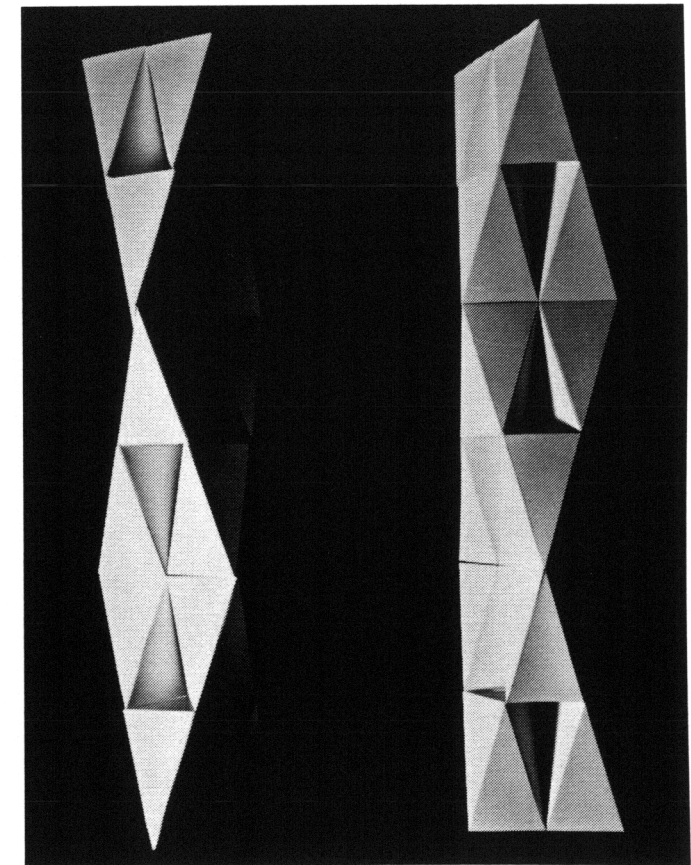

Selected Bibliography

- Bachelard, Gaston, *The Poetics of Space*, Beacon Press, Boston, 1969.
- Badawy, Alexander, *Ancient Egyptian Architectural Design, A Study of the Harmonic System*, University of California Press, Berkeley, 1965.
- Balfour, Michael, *Stonehenge and Its Mysteries*, Charles Scribner's Sons, New York, 1980.
- Brecher, Kenneth and Feirtag, Michael, Editors, *Astronomy of the Ancients*, The MIT Press, Cambridge, MA, 1981.
- Burl, Aubrey, *The Stone Circles of the British Isles*, Yale University Press, New Haven, 1976.
- Critchlow, Keith, *Time Stands Still*, St. Martin's Press, New York, 1982.
- Critchlow, Keith and Lawlor, Robert, *Geometry and Architecture*, Lindisfarne Press, Stockbridge, MA, 1980.
- De Cenival, Jean-Louis, *Living Architecture, Egyptian*, Grosset & Dunlop, New York, 1964.
- Doczi, Gyorgy, *The Power of Limits*, Shambhala Press, Boston, 1985.
- Eliade, Mircea, *The Sacred and The Profane*, Harper & Row, Publishers, New York, 1959.
- Gideon, S., *The Eternal Present, The Beginnings of Architecture*, Bollingen Foundation, Pantheon Books, New York, 1964.
- Hawkins, Gerald S., *Stonehenge Decoded*, Dell Publishing, New York, 1965.
- Hawkins, Gerald S., *Beyond Stonehenge*, Harper & Row, Publishers, New York, 1973.

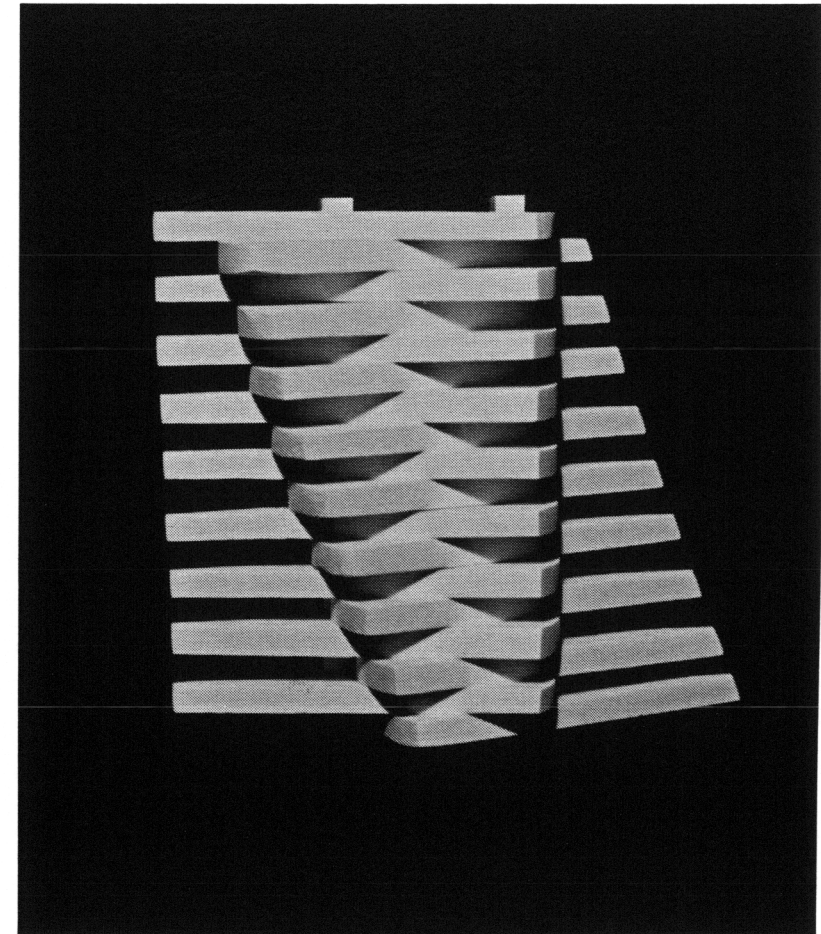

Krupp, E.C., Editor, *In Search of Ancient Astronomies*, McGraw Hill Books, New York, 1978.

Lawlor, Robert, *Sacred Geometry*, Crossroad Pub., New York, 1982.

Lobell, John, *Between Silence and Light*, Shambhala Press, Boston, 1979.

Neihardt, John G., *Black Elk Speaks*, University of Nebraska Press, Lincoln, 1961.

Norberg-Schulz, Christian, *Genius Loci, Towards A Phenomenology Of Architecture*, Rizzoli Press, New York, 1976.

Pennick, Nigel, *Sacred Geometry*, Harper & Row, New York, 1980.

Ponting, Gerald and Ponting, Margaret, *New Light on the Stones of Callanish*, G & M Ponting Publishers, Callanish, Scotland, 1984.

Raeburn, Michael, *An Outline of World Architecture*, Crown Publishers, New York, 1973.

Schwaller de Lubicz, R.A., *The Egyptian Miracle, An Introduction to the Wisdom of the Temple*, Inner Traditions International, New York, 1985.

Staal, Julius D.W., *The New Patterns in the Sky*, The McDonald and Woodward Publishing Co., Blacksburg, VA, 1988.

Thompson, D'Arcy, *On Growth and Form*, Cambridge University Press, England, 1961.

Tompkins, Peter, *Secrets of the Great Pyramid*, Harper & Row, Publishers, New York, 1971.

Volwahren, Andreas, *Living Architecture, Indian*, Grosset & Dunlop, New York, 1969.

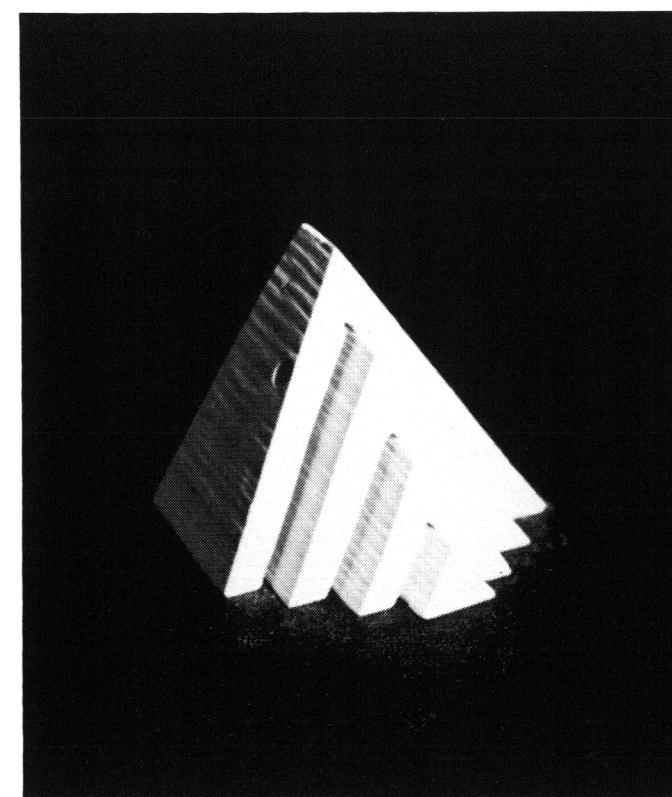

Vita

Scott A. Ogburn
 P.O. Box 161
 Spinnerstown, PA
 18968

Education:	Virginia Polytechnic Institute and State University Blacksburg, VA	1990 Master of Architecture
	Drexel University Philadelphia, PA	1986 Architectural Design
	Maxwell Institute Norristown, PA	1980 Computer Programming
	Bucks County Community College Newtown, PA	1979 Film Production Television Production
	Rhode Island School of Design Providence, R.I.	1974 Photography
	The University of Virginia Charlottesville, VA	1973 B.A. History
	Universite de Besancon Besancon, France	1971-1972 Art History French, European History
	The Choate School Wallingford, CT	Graduated 1969
Work Experience:	ArchVisions Blacksburg, VA	Director, Architectural Design 9/86 to Present
	Mitchell, Giurgola-Architects Philadelphia, PA	Model Building Christmas 1988

SACRED GEOMETRY

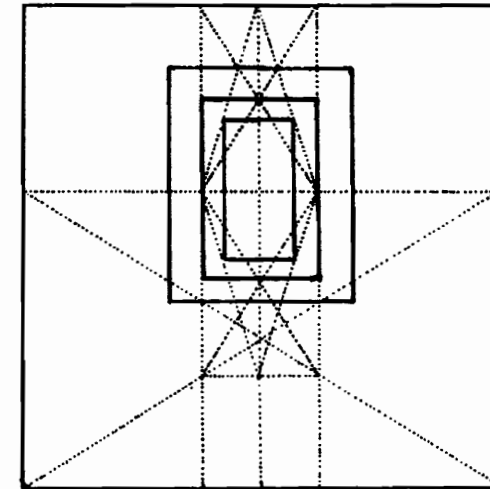

Geometric analysis of the tomb of Rameses IV of Egypt - double square and golden section rectangles.

Pennick, Nigel, *Sacred Geometry*, Harper & Row Pub., New York, p. 54.



Center Aisle Of Chephren's Valley Temple 19

Work Experience:	Dewberry, Davis Roanoke, VA	Architectural and Engineering Drafting 1990
	Venturi, Rausch & Scott Brown Philadelphia, PA	Computer-Aided-Design AutoCad Summer 1988
	Virginia Tech, Earthquake Research, Dr. Frederick Krimgold Blacksburg, VA	Computer-Aided Design AutoCad 1989
	Virginia Tech Blacksburg, VA	Graduate Teaching Assistant in Computer-Aided-Design, MacPaint CADAM, AutoCad 1987 to 1988
	Space Design, Inc. Philadelphia, PA	Designer, Director AutoCad Training 1/86 to 9/86
	Osiris Corporation Quakertown, PA	Director of C.A.D. Sales 5/83 to 9/85
	Orion Management Milford Square, PA	Director C.A.D. Consulting, Marketing 11/82 to 5/83
	Unami Galleries Quakertown, PA	Art Director 7/79 to 6/80
	Felluss Gallery Washington, D.C.	Art Director, Photographer 11/74 to 7/76
Scholarships:	Instructor Scholarship Virginia Tech, Blacksburg, VA	Computer-Aided-Design 1986-1987
	St. Andrew's Society of Washington, D.C.	Travel to England and Scotland in summer 1988 to study astronomical alignments of megalithic stone circles.

Scott A. Ogburn

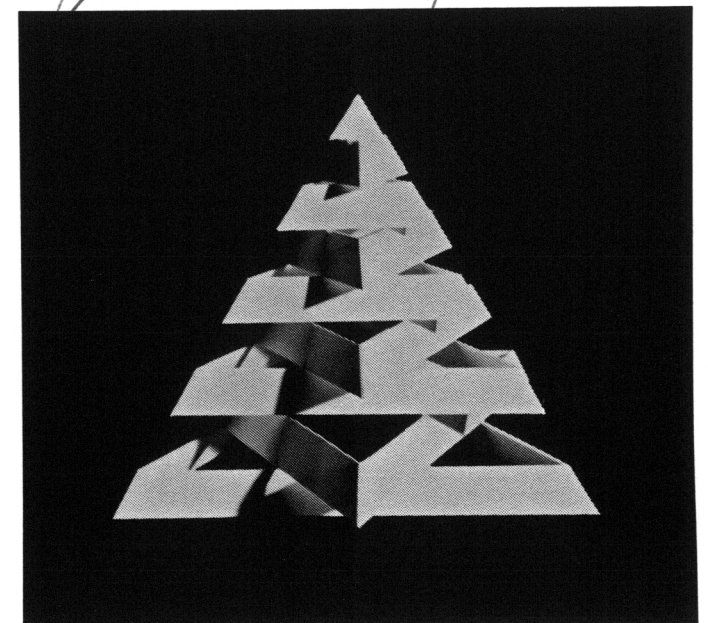



20

If the doors of perception were cleansed
Every thing would appear to Man as it is,
Infinite.

William Blake

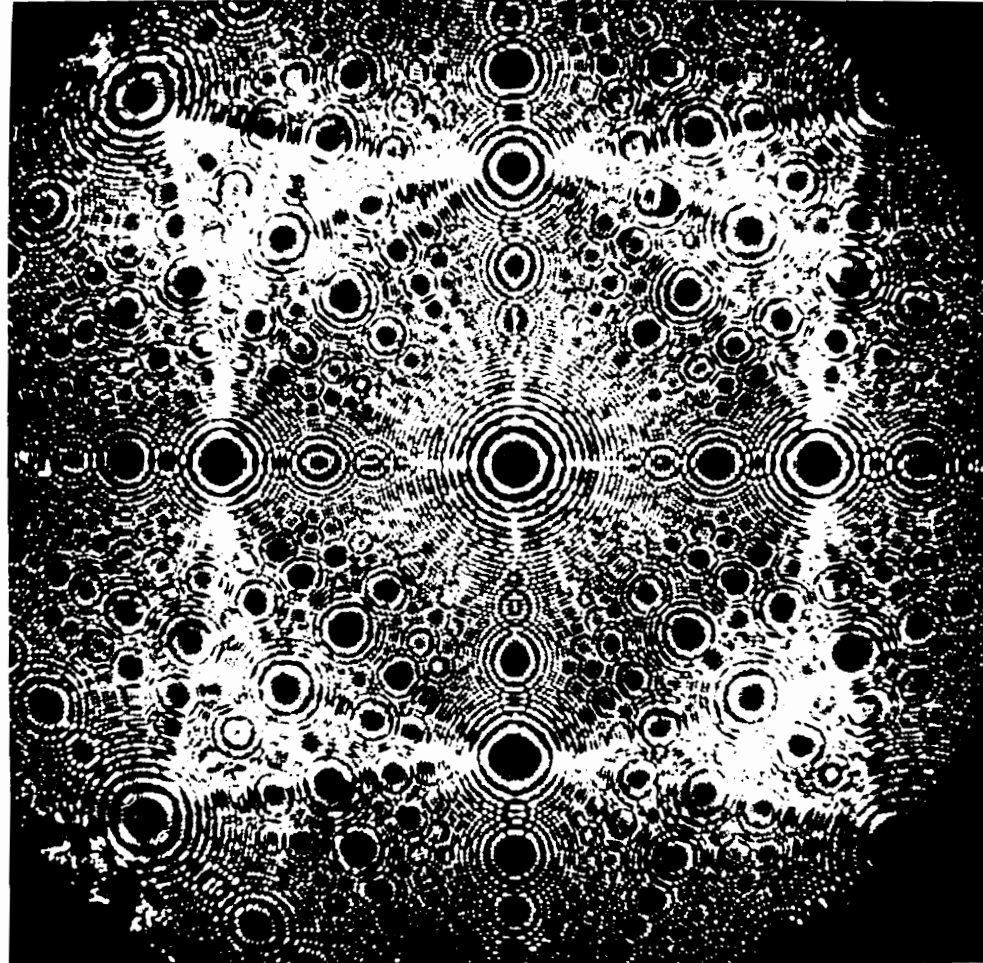

These refraction photos are the closest visualization that science can give with respect to the nature of atomic substance, which appears to be patterns of geometrized light-energy.

21

And all shall be well
All manner of things shall be well
When the tongues of flame are in-folded
Into the crowned knot of fire
And the fire and rose are one.

T.S. Eliot