

THE INFLUENCE OF SOIL RECONSTRUCTION METHODS ON MINERAL SANDS MINE SOIL PROPERTIES

Kelly Robyn Meredith

Thesis submitted to the Faculty of the Virginia Polytechnic Institute and State University in
partial fulfillment of the requirements for the degree of:

MASTER OF SCIENCE

In

Crop and Soil Environmental Sciences

W. Lee Daniels, Chair

Mark Alley

John Galbraith

Robert Grisso Jr.

December 12, 2007

Blacksburg, Virginia

Keywords: Reclamation, Revegetation, Bulk Density, Biosolids

THE INFLUENCE OF SOIL RECONSTRUCTION METHODS ON MINERAL SANDS MINE SOIL PROPERTIES

Kelly Robyn Meredith

(Abstract)

Significant deposits of heavy mineral sands (primarily ilmenite and zircon) are located in Virginia in Dinwiddie, Sussex and Greensville counties. Most deposits are located under prime farmland, and thus require intensive reclamation when mined. The objective of this study was to determine the effect of four different mine soil reconstruction methods on soil properties and associated rowcrop productivity. Treatments compared were 1) Biosolids-No Tillage, 2) Biosolids-Conventional Tillage, 3) Lime+NPK fertilized tailings (Control), and 4) 15-cm Topsoil over lime+P treated tailings. Treated plots were cropped to corn (*Zea Mays* L.) in 2005 and wheat (*Triticum aestivum* L.) in 2006. Yields were compared to nearby unmined prime farmland yields. Over both growing seasons, the two biosolids treatments produced the highest overall crop yields. The Topsoil treatment produced the lowest corn yields due to relatively poor physical and chemical conditions, but the effect was less obvious for the following wheat crop. Reclaimed land corn and wheat yields were higher than long-term county averages, but they were consistently lower than unmined plots under identical management. Detailed morphological study of 20 mine soil pedons revealed significant root-limiting subsoil compaction and textural stratification. The mine soils classified as Typic Udorthents (11), Typic Udifluvents (4) and Typic Dystrudepts (5). Overall, mined lands can be successfully returned to intensive agricultural production with comparable yields to long-term county averages provided extensive soil amendment and remedial tillage protocols are implemented. However, a significant decrease (~25 to 35%) in initial productivity should be expected relative to unmined prime farmland.

ACKNOWLEDGEMENTS

I would like to extend my thanks to Iluka Resources Incorporated who has worked diligently with Dr. W. Lee Daniels and his Marginal Soils Team to improve the mined land reclamation protocols applied at Old Hickory. Special thanks to Dr. W. Lee Daniels, Zenah Orndorff, Steve Nagle, Julie Burger, W.T. Price, Mike Beck, Mike Nester, Sue Brown, Pat Donovan, Dr. John Galbraith, Dr. Mark Alley, Dr. Bobby Grisso Jr., and anyone else in the CSES department at Virginia Tech whom I forgot to mention. Additionally, I would like to thank my family and friends for their support and guidance. Without your help, this would not have come to fruition. Furthermore, I would like to extend my thanks to Carl Clarke and his team for their management of the Carraway-Winn Reclamation Research Farm. Finally, thanks to Kay Winn and the Carraway Family for the use of their property and their support of improved reclamation science.

TABLE OF CONTENTS

1. INTRODUCTION AND BACKGROUND INFORMATION	1
1.1 Introduction.....	1
1.2 Study Objectives.....	3
1.3 Review of Pertinent Literature.....	4
<i>1.3.1 Soil Compaction</i>	6
<i>1.3.2 Soil Strength</i>	10
<i>1.3.3 Soil Compaction and Plant Rooting</i>	11
<i>1.3.4 Organic Matter Amendments</i>	12
<i>1.3.5 Reclamation Studies at Old Hickory</i>	14
2. MATERIALS AND METHODS	16
2.1 Site Descriptions.....	16
<i>2.1.1 Mining at Old Hickory</i>	23
<i>2.1.2 Dry Mill Mineral Processing Procedures</i>	26
<i>2.1.3 Active Mining Pits</i>	27
2.2 Relationship of Current Experiment to Previous Mine Soil Reconstruction Trials.....	34
2.3 Installation of Experimental Plots.....	36
<i>2.3.1 Detailed Research Plot Installation</i>	38
<i>2.3.2 Soil Sampling</i>	45
2.4 Overall Statistical Design and Analysis	49
3. RESULTS AND DISCUSSION	49
3.1 Mine Soil Properties Observed from Auger Profiles.....	49
<i>3.1.1 Auger Profile Summary</i>	49
<i>3.1.2 Mine Soil Properties</i>	50
3.1.2.1 Soil Color.....	50
3.2 Soil Physical Properties	51
<i>3.2.1 Soil Texture/Clay Content</i>	54
<i>3.2.2. Surface Bulk Density</i>	55

3.2.3 Soil Strength/Penetrometer Measurement.....	59
3.3 Soil Chemical Properties	61
3.3.1 Soil pH in 2005.....	61
3.2.2 Soil Macronutrients.....	63
3.2.3 Total Carbon Content.....	65
3.4 Rooting Observations.....	67
3.5 Crop Yield(s) as affected by Soil Reconstruction Treatment(s).....	69
3.5.1 Corn Yields (2005).....	70
3.5.2 Wheat Yields (2006).....	72
3.6 Detailed Soil Morphology and Taxonomy – Pit Study 2006.....	74
3.6.1 Soil Pit Summary.....	74
3.6.2 Soil Color and Overall Morphology.....	75
3.6.3 Important Subsoil Properties.....	94
3.6.4. Rooting Distribution.....	97
3.6.5 Soil Chemical Properties of Detailed Study Pedons.....	100
3.6.6 Soil Classification.....	102
4. SUMMARY AND CONCLUSIONS.....	102
REFERENCES.....	111
APPENDICES.....	117
<i>Appendix A - Flowcharts of the Wet and Dry Mill Processes and Pertinent Mining Terms.....</i>	<i>118</i>
<i>Appendix B - Detailed Plot Installation Procedures.....</i>	<i>126</i>
<i>Appendix C – Analysis of Lime-stabilized Biosolids (Arlington, VA) used in the Bio-CT and Bio-NT Treatments at the Carraway-Winn Reclamation Research Farm.....</i>	<i>129</i>
<i>Appendix D - Initial Soil Sampling (Fall 2004).....</i>	<i>132</i>
<i>Appendix E - Auger Soil Sample Data (Summer 2005).....</i>	<i>137</i>
<i>Appendix F - Auger Profile Descriptions for the Carraway-Winn Reclamation Research Farm (Summer 2005).....</i>	<i>142</i>

Appendix G - Soil Pit Sample Data (Summer 2006)..... 186

*Appendix H – Soil Profile Descriptions for the Carraway-Winn Reclamation Research
Farm and Clarke Farm Soil Pits (Summer 2006)*..... 195

VITA..... 216

LIST OF FIGURES

Figure 1: Regional map showing location of minerals sands ore bodies in Virginia which are highlighted in red.....	3
Figure 2: Final grading of mixed tailings and slimes at Old Hickory.....	7
Figure 3: Aerial view of Carraway-Winn Reclamation Research Farm with soil map overlay (Slagle fine sandy loam 10A, Myatt loam 26A, Dragston loamy sand 74A, Roanoke loam 29A, Nansemond fine sand 69B).....	18
Figure 4: Topographic map of pre-mining contours of the Carraway-Winn property located on the Old Hickory Mine.....	22
Figure 5: Mobile mining unit receiving ore.....	23
Figure 6: Bank of spirals in wet mill.....	24
Figure 7: Thickener tank where slimes are flocculated with anionic polymers and fall to bottom where they are removed and combined with tailings to be pumped to backfill mined out pits.....	25
Figure 8: Backfilled pit with rim ditch in place to aid dewatering.....	27
Figure 9: Aerial photo of active mining area at Old Hickory in 2006.....	28
Figure 10: Mined out pit with dike walls ready to receive tailings return.....	28
Figure 11: Granitic saprolite with Coastal Plain cobbles and weathered soil above.....	29
Figure 12: Backfilled pit receiving final capping of sandy tailings.....	30
Figure 13: Area of high slimes content being excavated and mixed by “dipping.”	31
Figure 14: Three-shank ripper being used to rip topsoil and subsoil in one pass.....	32
Figure 15: Topsoil being returned to re-graded mining pit.....	32
Figure 16: Flowchart of Iluka’s current mining and reclamation procedures.....	33
Figure 17: Aerial view of Carraway-Winn property on the Old Hickory mine site of Iluka Resources Inc.....	37
Figure 18: Aerial view of Carraway-Winn property on the Old Hickory mine site of Iluka Resources Inc.....	37
Figure 19: Diagram of soil reconstruction row crop experiment and overall plot design located on the Carraway-Winn Research Farm (CWRF) of the Old Hickory site.....	38
Figure 20: Diagram of one complete block of row crop experiment and plot layout.....	39
Figure 21: Deep shank ripper used to cross-rip experimental plots at Old Hickory.....	41

Figure 22: Plot of surface (7+ cm) bulk density (g/cm ³) taken at 7-cm block*treatment interaction effects for samples from the Carraway-Winn Reclamation Research Farm in summer 2005.....	56
Figure 23: Plot of penetrometer means (psi) showing block*treatment interaction for subsurface soil samples (30 cm) at the Carraway-Winn Reclamation Research Farm	60
Figure 24: Corn yields along the center transect of each plot located on the Carraway-Winn Research Farm (CWRF) of the Old Hickory site.....	72
Figure 25: Profile 404-1 (Bio-NT) is a Typic Udorthent as indicated by the lack of pedogenic horizonation or other distinctive soil morphological features (Table 20).....	77
Figure 26: Profile 302-3 (Bio-CT) is a Typic Dystrudept as indicated by weak development of a (Bw) pedogenically-altered horizon (Table 20).....	78
Figure 27: Profile 204-3 (Bio-CT) is a Typic Udifluent as indicated by a lack of pedogenic horizonation and an irregular decrease in Total C (+ 0.2 %) within the particle control section (25 to 100 cm) of the profile (Table 20).....	79
Figure 28: Profile 203-3 (Control) was a Typic Udorthent with a prominent densic layer (Cd) at 30 to 59 cm (Table 20).....	80
Figure 29: Profile EC 11-2 is a typical plot of the Compacted Area (Table 20).....	81
Figure 30: Profile 201-2 in a Topsoil plot (Table 20).....	82
Figure 31: A close-up view of Profile 103-2 (Control) showing rounded faces on dewatered chunks of slimes.....	90
Figure 32: Several subsoil horizons within pits were characterized by thin bands of heavy minerals and tailings that were overturned and deformed as referred to by Orndorff et al. (2005) as convoluted banding.....	91
Figure 33: Southern wall of CWRF 101-4 (Ripping traces highlighted in red).....	92
Figure 34: Alternating layers of tailings (lighter sandy material) and slimes (red clayey material), with thin bands of black HMS.....	93
Figure 35: Wood ash and charcoal material in CWRF 103-2 (Control) at 52 to 60 cm.....	94
Figure 36: Root masses along desiccation cracks.....	99
Figure 37: Root masses along desiccation cracks exposed after soil pit was excavated.....	100
Figure A-2: Flowchart 2 – Flowchart of Iluka’s current wet mill procedures.....	120
Figure A-3: Flowchart 3 – Flowchart of Iluka’s current dry mill procedures.....	122

LIST OF TABLES

Table 1:	Taxonomic detail on pre-existing native soils at the Carraway-Winn Reclamation Research Farm, Compacted Area and on the Clarke Farm.....	20
Table 2:	Soil chemical analysis of two composite topsoil stockpiles (October 2004).....	42
Table 3:	Mean depth to the plow layer (Ap) by treatment at the Carraway-Winn Reclamation Research Farm (Summer 2005).....	51
Table 4:	Occurrence of buried A horizons, densic properties, and observed water tables from auger borings.....	53
Table 5:	Mean clay content (0 to 15 cm) by treatment at the Carraway-Winn Reclamation Research Farm (Summer 2005) and external comparison plots.....	54
Table 6:	Mean surface bulk densities for the Carraway-Winn Reclamation Research Farm (Summer 2005).....	55
Table 7:	Comparison of soil texture with surface bulk density for the Carraway-Winn Reclamation Research Farm samples collected over the summer of 2005.....	57
Table 8:	Average particle density for a representative set of samples taken from soil pits for the Carraway-Winn Reclamation Research Farm (Summer 2006).....	58
Table 9:	Average surface and subsurface soil strength for the Carraway-Winn Reclamation Research Farm (Spring 2007) as estimated with a penetrometer.....	59
Table 10:	Mean surface (0 to 15 cm) and subsurface (50 to 65 cm) soil pH by treatment for the Carraway-Winn Reclamation Research Farm (Summer 2005) and external comparison areas.....	62
Table 11:	Mean surface (0 to 15 cm) and subsurface (50 to 65 cm) acid-extractable P (mg/kg) for auger samples at the Carraway-Winn Reclamation Research Farm (Summer 2005) and external comparison areas	64
Table 12:	Mean surface (0 to 15 cm) and subsurface (50 to 65 cm) calcium (mg/kg) for the Carraway-Winn Reclamation Research Farm and external comparison areas.....	65
Table 13:	Mean surface (0 to 15 cm) total carbon (mg/kg) for auger samples at the Carraway-Winn Reclamation Research Farm and external comparison areas.....	66
Table 14:	Mean depth of detectable rooting by treatment at the Carraway-Winn Reclamation Research Farm (Summer 2005) and external comparison plots.....	67

Table 15: Mean root counts at 42 cm (16.5 in.) by treatment at the Carraway-Winn Reclamation Research Farm (Summer 2005) and external comparison plots.....	68
Table 16: Average corn seedling count and seedling height by treatment on May 18, 2005...	69
Table 17: Corn yield by treatment for 2005 and average yields between 2001 and 2005 for Dinwiddie County, Virginia.....	71
Table 18: Wheat yield by treatment and five-year county averages for Dinwiddie, Virginia..	73
Table 19: Taxonomic classifications for the Carraway-Winn Reclamation Research Farm and Compacted Area soil pedons.....	75
Table 20: Profile descriptions of six representative mineral sands mine soil pictured earlier..	83
Table 21: Important taxonomic soil profile characteristics including Bw, densic layers, strong Sulfidic odor, etc.	97
Table 22: Mean depth to detectable rooting by treatment in soil pits at the Carraway-Winn Reclamation Research Farm (Summer 2006) and external comparison areas.....	98
Table 23: Mean surface and subsurface soil pH values for the CWRF and Compacted Area soil pedon samples (2006).....	101
Table B-1: Chronology of soil amendments for the CWRF, Compacted Area, and Clark Farm Control.....	127
Table B-2: Chronology of soil irrigation for the CWRF, Compacted Area and Clark Farm.....	128
Table D-1: Soil chemical analysis of experiment blocks one and two.....	133
Table E-1: Percent clay, percent sand and textural classes at 0 to 15-cm for the CWRF (2005)	138
Table E-2: Percent clay, percent sand and textural classes at 0 to 15-cm for the Compacted Area (Summer 2005).....	140
Table E-3: Percent clay, percent sand and textural class at 0 to 15 cm for the Clarke Farm/offsite Control.....	141
Table G-1: Horizon depths, roots per horizon, soil texture, percent clay and soil pH in all pedons described at the CWRF over the summer of 2006.....	187
Table G-2: Depth to rooting, roots per horizon, soil texture, percent clay and soil pH per soil pit for the Compacted Area/external control taken over the summer of 2006.....	193

I. INTRODUCTION AND BACKGROUND INFORMATION

1.1 Introduction

Heavy mineral sands (HMS) consist of titanium bearing minerals such as ilmenite ($\text{Fe}\cdot\text{TiO}_3$), leucoxene ($\text{FeTiO}_3\cdot\text{TiO}_2$), and rutile (TiO_2). Other valuable minerals such as monazite ($\text{Ce, La, Th, Nd, Y PO}_4$) and zircon (ZrSiO_2) are also found in these deposits. The term “heavy” refers to the mineral’s high specific gravity, $\geq 4.0 \text{ g/cm}^3$, relative to the host sands, which usually consist of quartz with a particle density of 2.67 g/cm^3 (Brooks, 2000). Heavy mineral sands deposits are derived from various fluvio-marine re-sorting of sediments derived from igneous, metamorphic and sedimentary rocks. Due to their high specific gravities, heavy minerals separate from lighter minerals via wave action and are subsequently concentrated in near-shore beach deposits that are frequently preserved in ancient Coastal Plain terraces (Lynd & Lefond, 1983). Australian companies dominate the mineral sands mining industry due to high concentrations of rich deposits of zircon and rutile along the coasts of Australia (Shepherd, 1986). The dominant market mineral is TiO_2 , (rutile) which is used as an opaque agent in paints. Titanium is also used in high strength metals applications and Zr is used as a refracting agent for high temperature ceramics and glazes.

Mineral sands mining was first reported in the United States at Pablo Beach near Punta Vedra in Florida in 1916 (Lynd & Lefond, 1983). Following the Pablo Beach operation, the Riz Mineral Company near Melbourne, Florida began mining operations in the 1940’s and 1950’s, as well as Humphrey’s Gold Company at the Regency deposits near Jacksonville, Florida, from 1943 until 1964 (Brooks, 2000). Other operations were recorded at Boulouge, Florida (1974 to 1979), at Folkston, Georgia (up to 1974), at Lakehurst, New Jersey (1962 & 1978) and at the Manchester mine near Lakehurst (1973 & 1982) (Lynd & Lefond, 1983). Current USA

operations are located at Trail Ridge and Green Cove Springs, in northeastern Florida, and at Old Hickory in southeastern Virginia (Fig. 1) with significant deposits available for future mining near Emporia, Virginia and in North Carolina east of Raleigh (Brooks, 2000).

The beneficiation process of HMS varies greatly with the surrounding host materials and associated soil landscapes. In Florida (and most of Australia), the process involves wet-dredging the ore, using wet separation via cyclones and spirals to separate the ore by gravity, and electrostatic/electromagnetic final separation of minerals. No chemicals are used in the beneficiation process other than NaOH and H₂SO₄, which are used to remove Fe and/or humate coatings from the ore before final electrostatic separation. Given that the majority of HMS mines worldwide do not support intensive pre-mine agriculture, detailed soil profile reconstruction protocols are seldom employed to establish vegetation cover for reclamation permit release. However, many areas in Australia have been returned to complex native heath and forest covers via sophisticated topsoil and seed bank return and mulching procedures (Brooks, 2000). Several mineral sands mines in western Australia have been reclaimed to pasture land, and in Florida, several mineral sands mines have been returned to commercial pine plantings.

Unlike the Florida and Australia HMS deposits, Virginia faces unique reclamation challenges. These challenges include: (1) the high clay content of the pre-mining soil, (2) the well-drained soil landscape, and (3) the fact that most of the mineable ore is located under prime farmland. Therefore, mining and reclamation processes are much more demanding at the mining area I studied in Virginia (Fig. 1), which is referred to herein as “Old Hickory”.

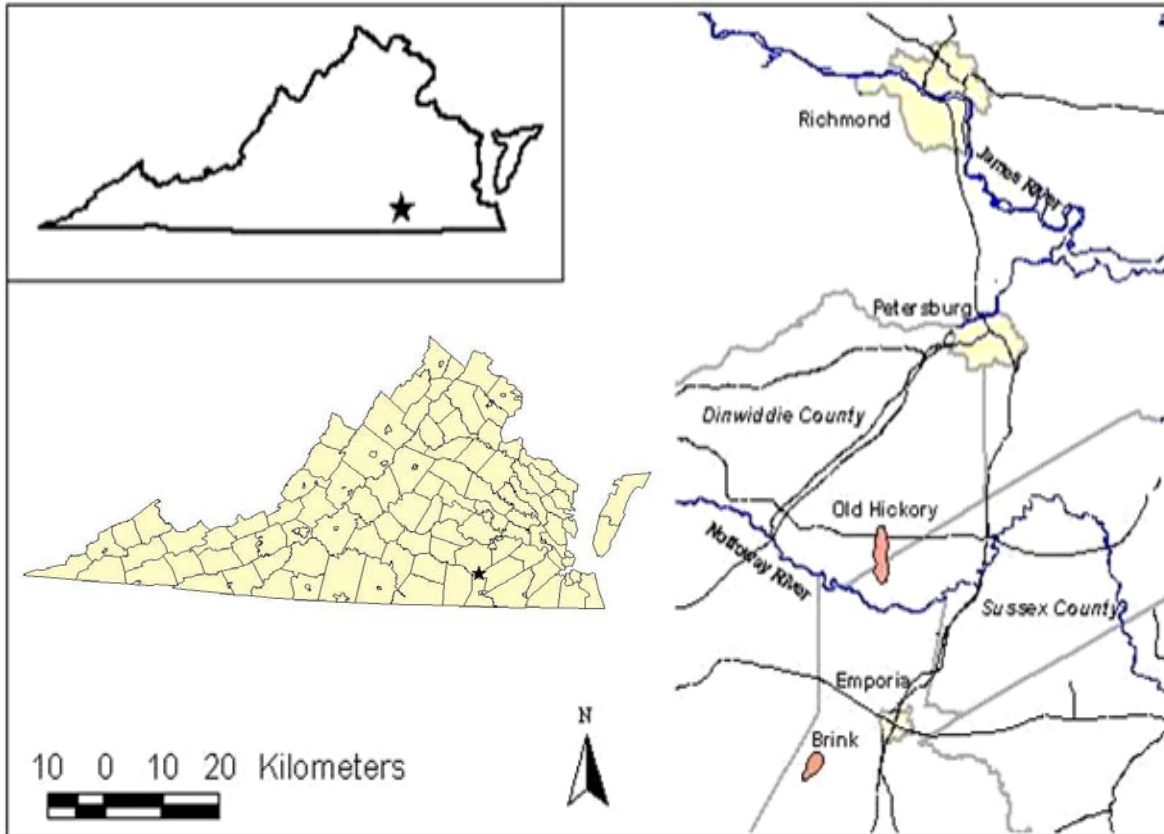

Figure 1. Regional map showing location of mineral sands ore bodies in Virginia which are highlighted in red. Similar ore bodies are located in North Carolina. The Old Hickory mine site is situated in both Dinwiddie and Sussex counties, Virginia (indicated by a black star).

1.2 Study Objectives

The overall goal of this study was to document the effect of various reconstruction techniques on mine soil properties and row-crop productivity on a mineral sands mine in southeastern Virginia. This study was designed with the following specific objectives:

1. To determine the effects of three different soil reconstruction practices on resultant mine soil morphological, physical and chemical properties. Specific reconstruction

practices evaluated were topsoil return, organic amendment with biosolids, and direct utilization of limed and fertilized tailings.

2. To estimate the effects of mine soil reconstruction practices on row crop productivity, and to compare the productivity of the mine soils with nearby undisturbed prime farmland.

3. To document and measure the relationships between soil morphological, chemical and physical properties and crop rooting as influenced by differential soil reconstruction practices.

4. To describe and classify a range of mine soil pedons occurring on the Carraway-Winn Research Farm at Old Hickory.

1.3. Review of Pertinent Literature

Mine soils, weathered spoils, drastically disturbed soils, and certain human or man-influenced soils are (Sencindiver and Ammons 2000) “soils formed on landscapes altered by human activities such as mining.” Mine soils have been drastically altered by the mining and beneficiation processes of overburden removal, ore excavation and subsequent return to fill mining pits or to cover adjacent areas. Although the original native soil profile is destroyed, a new profile begins to form immediately following reclamation (Daniels et al., 1981; DeMent et al., 1992). The chemical and physical properties of new mine soils are strongly influenced by the properties of the mixed overburden and weathered spoils that are returned by reclamation, filling,

and grading practices. Where natural soil horizons are segregated and returned to the reclaimed surface, their inherent properties dominate the upper layers of the reclaimed profile. When non-soil materials are placed on the surface, young mine soil profiles rapidly develop a thin A horizon underlain by an AC or C horizon. Daniels et al. (1981) concluded that distinct A horizons may develop in mine soils as young as five years. Coal mine soils have been the most extensively studied, and commonly have variable soil texture and color, weak to moderate structure in their surface horizons, and are often excessively compacted (Haering et al., 2004). Sencindiver and Ammons (2000) concluded that drastically disturbed soils frequently exhibit the following soil properties: 1) disordered coarse fragments, 2) randomly oriented pockets of dissimilar materials (clay and sand), 3) color mottling not related to drainage, and 4) bridging voids – large coarse-fragment controlled air spaces created during mine spoil deposition and grading.

Mechanical compaction in mine soils resulted in high bulk densities and associated high soil strength--leading to inadequate root penetration and rates of water and gas movement (Sencindiver & Ammons, 2000). In a study by Thurman et al. (1985) of topsoiled and non-topsoiled mine soils, adjusted bulk density (D_b) values were significantly higher for all depths of mine soils that had been topsoiled. Thurman et al. attributed this increase to the heavy equipment used to place and grade the topsoil material. These newly created soils generally lack the interconnected macropore network necessary for sufficient water movement and aeration (Dunker et al., 1995). In addition, mine soils, depending on their parent material, may possess high (or low) soil pH, variable levels of fertility, and are generally low in cation exchange capacity.

1.3.1 Soil Compaction

Excessive compaction plays an important role in the development and productivity of mine soils (Barnhisel & Darmody, 2000). Compaction has been reported as the most restrictive feature in several mineral sands reclamation studies (Daniels et. al., 1999, 2003a). Depth of compaction varies depending upon the equipment used during the reclamation process, materials handling methods used during soil reconstruction, and nature of the spoil material being placed and graded. McSweeney and Jansen (1984) advocated that the type of material handling methods utilized during soil reconstruction can result in soils having physical and structural characteristics which restrict root growth. They utilized a wheel-conveyor spreader system to replace various soil and topsoil mixes on a reclaimed mine soil at the Captain Mine in Perry, Illinois. Their results indicated that; 1) a ‘fritted,’ or an artificial soil structure that consists of rounded aggregates loosely compressed due to soil handling, favors good rooting depth as compared to massive subsoils with shallow and restricted rooting and 2) operations using a mining wheel conveyor spreader system favor this ‘fritted’ soil structure more than operations using a typical scraper system. Similarly, Pedersen et al., (1980) report that excessive soil compaction is associated with: 1) ponding of surface water (i.e. poor infiltration rates); 2) poor rooting ability for herbaceous cover; 3) excessively high bulk densities; and 4) low porosity. Considering that soil compaction compresses and reduces pore size within and between soil peds, water movement is impeded, thus causing poor infiltration rates, low porosity and ponding of surface water depending on which layer is compacted.

Reduction in the overall bulk density of the soil increases both water infiltration and plant root development. Densities as high as 1.8 g/cm^3 have been documented in restored mineral sands mine soils due to wet settling and bulldozer consolidation of mine tailings coupled together

with final topsoiling and grading activities in Florida and Virginia (Daniels et al., 1992; Orndorff et al., 2005) (Fig. 2).



Figure 2. Final grading of mixed tailings and slimes at Old Hickory. Lime and P are added to this surface and mixed with chisel plow before the topsoil is returned. Photo courtesy of Chuck Stilson/Iluka.

As described below, various tillage techniques such as deep ripping, a mixture of deep ripping and disking, etc., have been studied and recommended in other mined areas (e.g. Midwestern USA coalfields) to mitigate high bulk densities. Overall, as also discussed below, compaction has been reported as the major soil factor limiting crop yields on coal mine soils recreated on prime farmlands in the Mideastern and Midwestern USA (Barnhisel & Gray, 1990).

Caldwell et al. (1992) conducted a three-year study to determine the depth and ripping effects of a reconstructed coal mine soil on grain sorghum (*Sorghum Se.*) and soybeans (*Glycine Max*) yields on a reclaimed prime farmland in Southeastern Kansas. Twelve experimental (54 x

54 m) plots were constructed in the fall of 1985 at P & M Midway mine located in Linn County, Kansas. Approximately 30 cm of topsoil was placed over varying depths of subsoil; 0, 30, 60 and 90 cm on graded mine spoil. Additionally, one half of each block was ripped with a chisel subsoiler to a depth of 51 cm prior to planting (1st year). Crop yields on all subsoil treatments were generally low each year studied for both grain sorghum and soybeans. They advocated that shallow rooting limited crop yields on soils \leq 30 cm rooting depth. In addition, Caldwell et al. reported that ripping to a depth of 51 cm alleviated drought stress and increased overall crop yields.

Dunker et al. (1995) studied five tillage treatments on reconstructed surface coal mine soils on the Consolidation Coal Company Burning Star no 2 mine near Pinckneyville in Perry County, Illinois. Given that these soils had once been prime farmland, adequate soil reconstruction and tillage/ripping techniques were required by law before bond release could occur. Overall, this major study established that: 1) tillage significantly affected crop production, biomass production, soil strength and net water extracted by crops; 2) average soil strength, or rooting resistance, was inversely proportional to tillage depth; 3) soil strength was inversely correlated to crop yield; 4) crop yield increased with tillage depth, 5) penetrometer data indicated that the benefits of deep tillage persisted for up to five years; and 6) initial levels of soil strength affected the depth of tillage required for greater productivity. Dunker et al. also found that corn productivity did not significantly exceed the Cisne silt loam (Fine, smectitic, mesic, Mollic, Albaqualfs) unmined control for any of the five treatments studied over the course of the experiment; however, the highest yields were measured in 1993 with two of the treatments (DM1- deep ripped to 120 cm and DM2 – a modified version of DM1 deep ripped to 120 cm) which produced 4 % and 6 % higher yields than the control. Soybeans produced similar results

with DM1, DM2, DM3 – 90 cm depth, and TG2 – 35 cm depth, producing 33%, 34%, 25%, and 3 % higher yields than the undisturbed Cisne control for 1993 only.

Wells and Barnhisel (1992) conducted a similar study at two surface mined sites in Muhlenberg County, Kentucky. Reconstructed and undisturbed prime farmland soils at the River Queen and Gibraltar surface mines were utilized in their experiment. Results indicated that: 1) lower subsoil bulk density was more common within the ripped plots than the non-ripped plots; and 2) no significant differences were noted between the two soil placement methods studied (truck dump vs. scraper pan soil placement). Hooks et al. (1992) also studied corn and soybean response from 1985 through 1991 in southern Illinois. Their study focused on different soil reconstruction methods (soil replaced via end-dump trucks vs. scraper pan placed material). They found that soil material replaced via a shovel-truck system produced a more productive soil than soil material replaced using a scraper system if surface traffic is controlled and minimized to avoid unnecessary compaction. Truck-hauled soil material with and without surface traffic (TWT vs. TNT) did not exceed the Cisne silt loam control for corn production or soybean yields during all years studied. However, the TNT treatment (w/out traffic) produced 106%, 175%, 272%, 101%, and 142% more corn than the Stoy silt (fine-silty, mixed, superactive, mesic, Fragiaquic Hapludalfs) loam control for 1986, 1988, 1989, 1990, and 1991 years respectively. The TNT treatment only produced significantly greater soybean yields in 1987. The TWT treatment (with traffic) produced 55% (1986), 70% (1988), 132% (1999), 46% (1990), and 84% (1991) more corn than the Stoy silt loam control. The TWT treatment did not produce significantly greater soybean yields. In another study conducted by Witsell and Hobbs (1965), a silt loam soil was compacted to approximately 1.65 Mg/m^3 at depths of 0 to 15 cm and 0 to 30

cm. They reported that wheat yields were reduced by 20 to 30% and 12 to 20% at 0 to 15, and 0 to 30 cm, respectively, relative to undisturbed soil conditions.

In one particularly notable long-term study, Barnhisel (2006) studied reconstructed mine soil productivity on a reclaimed surface coal mine in western Kentucky over a period of 22 years. Treatments were as follows: 1) non-prime farmland soil (20-cm of topsoil cover); 2) 40 cm of subsoil (a mixture of B2 and Bt material); and 3) 80 cm of the subsoil mixture previously mentioned followed by 20 cm of Ap (topsoil material). All treatments were placed using a scraper-pan over replaced overburden/spoil. Target yields for all crops tested (alfalfa (*Medicago sativa*), corn, grain sorghum, soybeans, tall fescue (*Festuca elatior*) and wheat (*Triticum* spp.) met yield requirements for Phase III bond release (per SMCRA, Surface Mine Control and Reclamation Act of 1977) requirements of ≥ 90 % of county average for all three soil treatments studied. Although, target yields for alfalfa were only met in 1981, 1982, and 1983, all three treatments (20 cm, 60 cm and 100 cm) produced approximately 8 % more than their required targets. Unlike alfalfa, target yields for corn were met in 1982 and 1983 only. Additionally, only the 60-cm and 100-cm treatments met required targets producing approximately 3 %, and 15 % more than their required targets respectively.

1.3.2 Soil Strength

Many researches have suggested that soil strength, or mechanical resistance, and not bulk density per se, is the most important limiting factor in the reduction of root elongation and overall plant growth (Taylor and Gardner, 1963; Taylor and Burnett, 1964). Mechanical resistance is a measure of the real resistance that roots encounter as they grow through the soil (Phillips & Kirkham, 1962). Thompson et al. (1987) evaluated the effectiveness of penetrometer

resistance measurements and bulk density to see which method was more accurate for predicting root system performance on coal mine soils located in southern Illinois. Their results indicated 1) that both penetrometer resistance and bulk density were good predictors of root system performance, 2) penetrometer resistance and bulk density were highly correlated within the lower root zone (unlike at the soil surface), and 3) bulk density generated a slightly higher R^2 value than penetrometer resistance ($R^2 = 0.81$ and 0.73 respectively), suggesting that it was the better predictor of effective depth to rooting. Vance et al. (1992) also studied soil strength measurements at three reclaimed prime farmland plots in Southwestern Illinois. Plots were reconstructed using a variety of reclamation methods and soil strength measurements were taken to a depth of 112 cm (44 inches). Their results indicate that soil strength was highly correlated to corn and soybean yields; crop yields decreased significantly as soil strength increased.

1.3.3 Soil Compaction and Plant Rooting

The adverse effects of soil compaction and high soil strength on mine soil productivity are directly related to plant rooting limitations. Plant roots have three primary functions: 1) they anchor the plant in the soil; 2) they absorb water and nutrients for the plant to use during photosynthesis; and 3) they synthesize organic compounds needed by the plant (Drew and Gross, 1973). In order to maintain a healthy plant-soil system, roots need to penetrate to sufficient depth and access associated rooting volumes. Most root growth occurs in soils with bulk densities ranging from 1.1 to 1.5 g/cm^3 , which is the commonly observed range in the upper 1 m of most undisturbed soils. However, the majority of coal and mineral sands mine soils in Virginia have much higher bulk densities (most likely due to soil compaction from haulage trucks and grading) within 1 m (Haering et al., 2004; Daniels et al., 2003a). Impeded aeration, a

direct result of increased soil compaction, also has the potential to inhibit root growth (Thompson et. al, 1987) independent of direct mechanical impedance effects. Various studies have shown that root growth is directly inhibited by high soil strength (Thompson et al., 1987, Taylor and Burnett, 1964) which is generally well-correlated with bulk density and moisture content in a given soil. Critical root limiting bulk densities in sandy soils are around 1.7 g/cm^3 due to their higher abundance of larger packing macropores, but finer textured soils will limit rooting at bulk densities as low as 1.40 g/cm^3 , particularly when they are dry and/or poorly structured (Brady and Weil, 2003).

The major effect of high soil strength/bulk density on overall plant performance is through rooting depth related to drought stress. Pearson (1974) reported that shallow rooting increased drought hazard to a wide range of crops. Crookston et al. (1992) conducted a study on subsurface compaction versus root/shoot growth on grain yields (wheat). For their study, compaction was artificially created on a clay loam soil in Tadla, Morocco. Their results indicated that: 1) compaction had no affect on root mass density; however, root length was significantly reduced, thus reducing overall yield production; 2) compaction significantly increased bulk density, by 9 to 14%; while 3) mechanical resistance was increased by 30 to 38% (2.0 to 3.3 MPa.). Daniels et al. (2003a) found that the overall depth of rooting on a reclaimed heavy mineral sands mine in Southeastern Virginia was generally limited to 50 cm (or less) due to subsoil compaction and a high seasonal water table.

1.3.4 Organic Matter Amendments

Various studies have shown that organic matter additions to mine soils increase water holding capacity, improve cation exchange capacity (CEC) and buffering, and also promotes

soil structure formation while reducing overall bulk density (Jansen, 1981; Smith et al., 1987). Stolt et al. (2001) conducted a study on a 20 x 60 m area of reclaimed HMS deposit located in Brink, Virginia. The study area was excavated to a depth of 5 m and treated in a manner similar to that of HMS mining operations at Iluka. Experimental plots were established with several reconstruction techniques: 1) a control (unamended tailings); 2) tailings amended with 23, 45, 90, 135 and 270 Mg/ha yardwaste compost; and 3) tailings capped with 45 cm of A horizon stockpiled during mining. Stolt et al. (2001) suggested that the addition of high levels of compost (>135 Mg/ha) increased water holding capacity via a significant increase in soil macroporosity and a significant decrease in bulk density. Furthermore, this study suggested that compost material improved not only the rooting environment but increased water percolation and soil gas exchange.

Research has also been conducted on the addition of various amendments to enhance revegetation of mine soils such as the addition of biosolids, the use of native topsoil, the use of topsoil substitute, and additions of lime and phosphorous (Daniels et. al., 1999). In a study conducted by Powell et al. (1986), deep ripping of the subsoil combined with biosolids additions (22 to 44 Mg/ha) produced ≥ 90 % of long-term county average target corn and sorghum yields on reclaimed prime farmland soils. Sopper and Kerr (1982) found that biosolids were superior to fertilizer on coal mined land that had undergone topsoil replacement. Zhai and Barnhisel (1996), found that biosolids applied to the subsoil at a rate of 34 Mg/ha and incorporated with a chisel plow before topsoil replacement not only increased corn yield (+ 29 %, + 18 %, and +155 % > control treatment for 1991, 1992, and 1993 respectively) but also improved soil chemical properties and physical properties within the rooting zone.

1.3.5 Reclamation Studies at Old Hickory

Greenhouse studies were conducted by Daniels et al. (1996) on generated simulated mine tailings and slimes from bulk soil samples at the Old Hickory mine site in Virginia. The greenhouse experiment consisted of two separate studies: 1) small pot studies; and 2) larger-scale 'barrel' experiments. These small-pot studies were employed in order to determine soil mix and P-fertilizer effects on crop growth. Larger scale 'barrel' experiments were developed to determine row crop growth potential of selected tailings and slimes mixes with and without topsoil cover (Daniels et al., 1996). Small pot experiments were also conducted by Daniels et al. in 1996. Six different soil mixes and five different phosphorus rates at 1) 100% tailings, 2) 85:15% tailings:slimes (T:S); 3) 70:30% T:S, 4) 55:45% T:S, 5) topsoil mix and 6) Orangeburg (fine-loamy, kaolinitic, thermic Typic Kandiudults) topsoil were compared. Phosphorus was added at 0, 40, 80, 120 and 160 mg/kg of P. Soybean yields were strongly affected by soil mix and P additions in this experiment. From the small pot experiments, Daniels et al. confirmed that P was limiting to soybean growth for all T:S mixes and that large initial P-fertilizer additions should be added to provide adequate P for row crops. Additionally, they determined that: 1) soybean growth was significantly reduced on the 100 % tailings material; and 2) the 85%:15% and 70%:30% T:S mixes performed better than the 100%:0% and 55%:45% T:S mixes respectively. The larger-scale barrel experiments were completed in March 1994. A wheat-soybean-corn cropping sequence was grown in 200 L barrels with five treatment that included; 1) Topsoil over 70:30% T:S; 2) Topsoil over 85:15% T:S; 3) Topsoil over pure tailings 100:0% T:S; 4) Biosolids + tailings as a topsoil substitute and 70:30% T:S; and 5) 70:30% T:S blend with no topsoil or topsoil substitute blend. Of the crops studied, only soybean responded to the

various soil blends and not corn or wheat. Additionally, their results suggested that a uniform blend of tailings and slimes material could be a productive topsoil substitute.

Between 1995 and 1998, Schroeder (1997) conducted a follow-up field study on the effects of 25 cm topsoil return vs. topsoil substitutes constructed by addition of yard waste compost at 112 Mg/ha to mixed tailings/slimes. Although he found no significant correlation between root length and bulk density for either treatment, he theorized that subsoil D_b was the major factor limiting both treatments and it was inversely related to crop yield (Schroeder, 1997). In addition, Schroeder's findings confirmed that even though subsurface D_b values between the adjacent undisturbed control plots and the pilot mining pits at Old Hickory did not differ, D_b in the mine soils covered a much larger range (concentrated slimes $\sim 1.0 \text{ g/cm}^3$; sandy horizons 1.6 to 1.9 g/cm^3). Schroeder's study utilized 112 Mg/ha yard waste compost incorporated into a mixture of tailings and slimes following a regime of heavy P-fertilization, liming, and V-ripping (Daniels et al., 1999, 2003b). Over a four-year cropping period of wheat, soybean, corn, and cotton (*Gossypium hirsutum*), the post-mining productivity, when compared to adjacent prime farmland, was reduced by 23%, 3%, 27%, and 20% respectively (Daniels et al., 2003a, 2003b). In addition, they concluded that neither treatment (Topsoil vs. Compost addition) appeared consistently superior, but both soil reconstruction approaches resulted in a net loss of multi-year crop productivity relative to Faceville series soils (Typic Paleudults) directly adjacent to unmined land.

Orndorff et al. (2005) conducted a study on thirteen pedons from four reclaimed mining pits at the Old Hickory mine. Their study focused on soil classification and characterization of the chemical, physical and morphological properties of these soils. She concluded that six of these pedons were Typic Udorthents, three were Typic Quartzipsamments, three were Typic

Udfluvents and one pedon which exhibited a cambic horizon was a Fluventic Dystrudept. Additionally, Orndorff et al. found six characteristics commonly observed within the subsurface horizons. These characteristics included: 1) occurrence of strongly contrasting particle-size classes; 2) significant color changes generally were associated with textural changes; 3) thin bands of tailings and slimes material; 4) thin bands of heavy mineral material; 5) convoluted banding-bands of tailings, slimes and heavy mineral sands materials that have been overturned and deformed; and 6) fragments of clayey materials--e.g. slimes or Coastal Plain substratum within a sandier matrix. Moreover, Orndorff et al. illustrated that these soils exhibited an A-C horization with generally acidic subsurface horizons ($\text{pH} \leq 5.5$), low OM and low CEC.

II. MATERIALS AND METHODS

2.1. Site Description

Mineral Sand Deposits were discovered in Virginia in the late 1980's (Berquist and Goodwin, 1989; Carpenter and Carpenter, 1991). The largest ore body in Virginia is known as the Old Hickory deposit, positioned along the Atlantic Coastal Plain in the counties of Dinwiddie and Sussex, Virginia. It covers approximately 2,550 ha (6,300 acres), and is located approximately 100 km (60 miles) south of Richmond and 175 km (110 miles) west of the Atlantic coastline (Schroeder, 1997; see Fig. 1). This deposit spans the "Fall Zone," or the boundary between the Piedmont and Coastal Plain physiographic provinces (Berquist and Goodwin, 1989). The surficial Coastal Plain sediments are Pliocene to early Pleistocene in age and overlies highly weathered Piedmont saprolites derived from granitic and felsic volcanic rocks.

Hodges et al. (2002) completed detailed soil mapping of the Old Hickory area in February 2002. Fig. 3 is an aerial view of the Carraway-Winn Reclamation Research Farm (CRWF) with a pre-existing soil map overlay. Approximately three-fourths of the research farm was originally covered in a Slagle fine sandy loam (fine-loamy, siliceous, subactive, thermic, Aquic Hapludults) with 0 to 2% slopes (Fig. 3). The remaining one-fourth was in a mixture of Roanoke loam (fine, mixed, semiactive, thermic Typic Endoaquults) on 0 to 2% slopes, Myatt loam (fine-loamy, siliceous, active, thermic, Typic, Endoaquults) on 0 to 2% slopes, Dragston loamy sand (coarse-loamy, mixed, semiactive, thermic, Aeric Endoaquults) on 0 to 3 % slopes and Nansemond fine sand (coarse-loamy, siliceous, subactive, thermic, Aquic Hapludults) on 0 to 4% slopes.

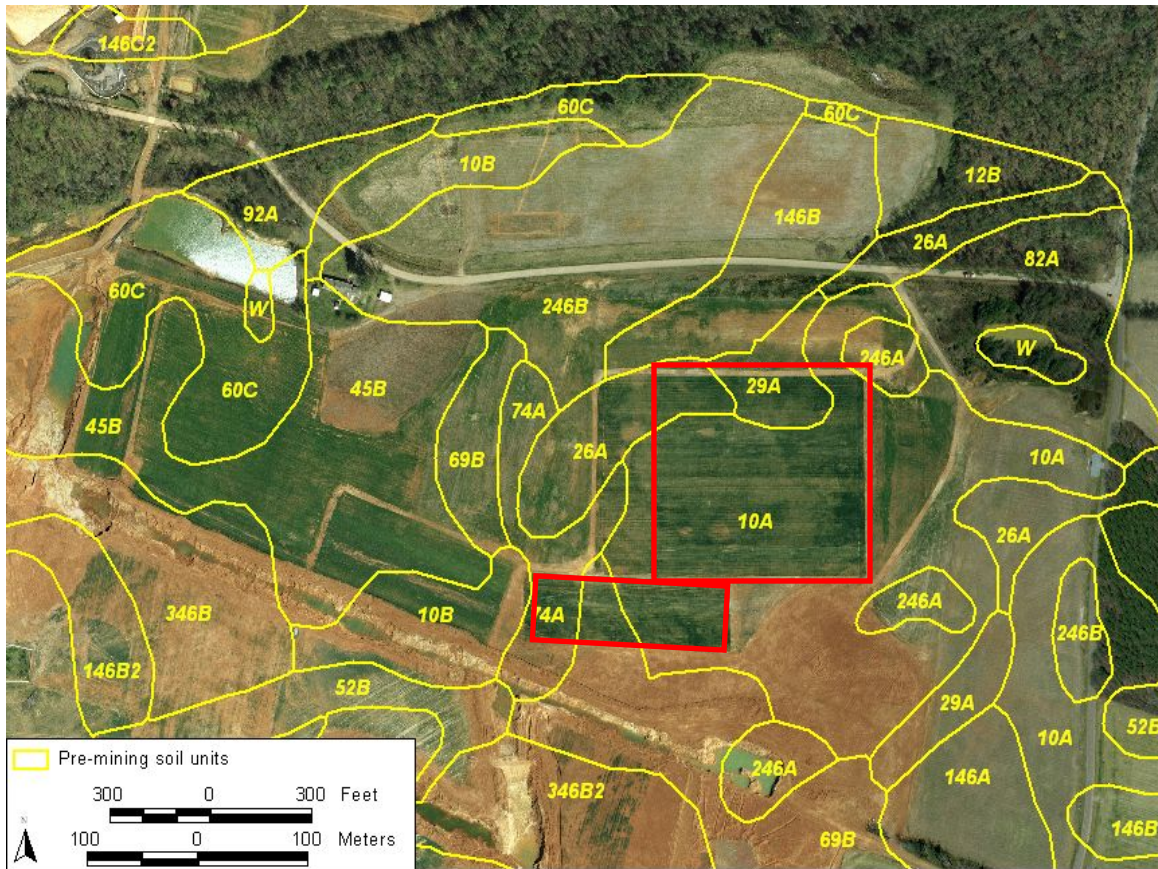

Figure 3. Aerial view of the Carraway-Winn Reclamation Research Farm with soil map overlay (Slagle fine sandy loam 10A, Myatt loam 26A, Dragston loamy sand 74A, Roanoke loam, 29A, Nansemond fine sand 69B) of the pre-existing native soils. The row crop soil reconstruction experiment is outlined in red. The area was dominated by new mine soils at the time of this photo in spring 2006.

The Slagle fine sandy loam consists of yellowish brown sandy clay material underlain by a variegated yellowish red/strong brown sandy clay loam. Organic matter and natural fertility are low with slow permeability. The rooting zone is generally more than 150 cm with moderate shrink-swell potential. The Slagle fine sandy loam is well suited for cropland as well as hay and pasture production. Additionally, Slagle has a very high potential as a profitable woodland soil. The Roanoke loam consists of a very dark brown surface horizon underlain by light brownish gray/grayish brown silty clay loams and sandy clays. Organic matter content and natural fertility are low with very slow permeability. The Roanoke loam is poorly drained with moderate to high

shrink-swell potential, and is poorly suited for cropland. The Myatt loam consists of a very dark grayish brown loam surface layer underlain by gray sandy loam/loam/clay loam and gravelly sandy clay subsurface horizons. Organic matter content and natural fertility are low with a moderate to moderately slow permeability. This soil is poorly drained with a low shrink-swell potential. The Dragston loamy sand consists of a brown loamy sand surface layer underlain by yellowish brown loamy sands/sandy loams subsurface horizons. Organic matter and natural fertility are low with a moderately rapid permeability, and it is well suited for cropland and hay and pasture land if drained. The Nansemond fine sand consist of a dark grayish brown fine sand surface horizon underlain by light yellowish brown loamy fine sand/sandy loam with brown iron masses. Organic matter content and natural fertility are low with a moderately rapid permeability rate, and it is dominantly used for woodland.

Additionally, the Clarke farm offsite control site (described later) is 100% Orangeburg loamy sand (Typic Kandiodults). Orangeburg loamy sand consists of a yellowish brown loamy sand surface layer, underlain by light yellowish brown/strong brown sandy clay loams and sandy clays. This soil is deep with low organic matter content and moderate permeability rate. It is well suited for cropland, hay and pasture land and is also highly profitable for loblolly pine (Table 1).

Table 1 – Taxonomic detail on pre-existing native soils at the Carraway-Winn Reclamation Research Farm, Compacted Area and on the Clarke Farm.

Series Name	Soil Map Units	Soil Taxonomy	Texture		Rooting Zone	Depth to bedrock	Land uses (Well Suited)
			Subsurface	Subsurface			
Slagle fine sandy loam	10 A	Fine-loamy, siliceous, subactive, thermic, Aquic Hapludults	Sandy Clay Loam	Sandy Clay Loam	> 152 cm	N/A	Cropland Hay/Pasture Woodland
Myatt loam	26 A	Fine-loamy, siliceous, active, thermic, Typic Endoaquults	Loam or Clay Loam	Loam or Clay Loam	> 152 cm	N/A	Cropland Hay/Pasture Woodland
Dragston loamy sand	74 A	Coarse-loamy, mixed, semiactive, thermic, Aeric Endoaquults	Loamy Sand	Loamy Sand	> 152 cm	N/A	Cropland Hay/Pasture Woodland
Roanoke Loam	29A	Fine, mixed, semiactive, thermic, Typic Endoaquults	Clay loam to Clay	Clay loam to Clay	> 152 cm	N/A	Woodland
Nansemond fine sand	69B	Coarse-loamy, siliceous, subactive, thermic, Aquic Hapludults	Fine Sand to Sandy Loam	Fine Sand to Sandy Loam	> 152 cm	> 152 cm	Woodland
Orangeburg Loamy sand	45A	Fine-loamy, kaolinitic, thermic, Typic Kandiudults	Sandy Clay Loam	Sandy Clay Loam	> 152 cm	> 152 cm	Cropland Hay/Pasture Woodland

Much of the Old Hickory deposit occurs under “prime farmland,” which has the most favorable combination of physical, chemical, environmental properties for the production of food, fiber and oil crops (Grandt, 1988). Historically, this has been an important peanut-, soybean-, tobacco- and cotton-producing region. Mining at Old Hickory was initiated in 1997 by RGC Minerals (Daniels et al., 1992). Heavy minerals are more resistant to weathering than other aluminosilicates and quartz, and thus accumulate in weathered surface soil horizons over time. This coupled with the fact that quartz sands are more prone to wind and water erosion leads to significant accumulation of heavy mineral in the native topsoil, and that layer is often the most profitable material for HMS mining (Milnes & Fitzpatrick, 1989). Thus, there is great interest in the possibility of using organic amendments such as biosolids, which are an end-product of municipal wastewater treatment (Walker, 1994) or yard waste as organic soil amendments to allow for topsoil substitution. However, current Virginia mining regulations require that the upper 15 cm of topsoil (A + E Horizons) be stockpiled and returned to the site after mining.

Iluka Resources, the company that currently mines at Old Hickory, acquired RGC Minerals by merger in early 1997. To date, over 1000 ha have been disturbed. This research project is focused on the Carraway-Winn property near the center of the deposit. Figure 4 shows a detailed topographic view of the Carraway-Winn property. A small black star near the center of the map indicates the Carraway-Winn Reclamation Research Farm, CWRF.

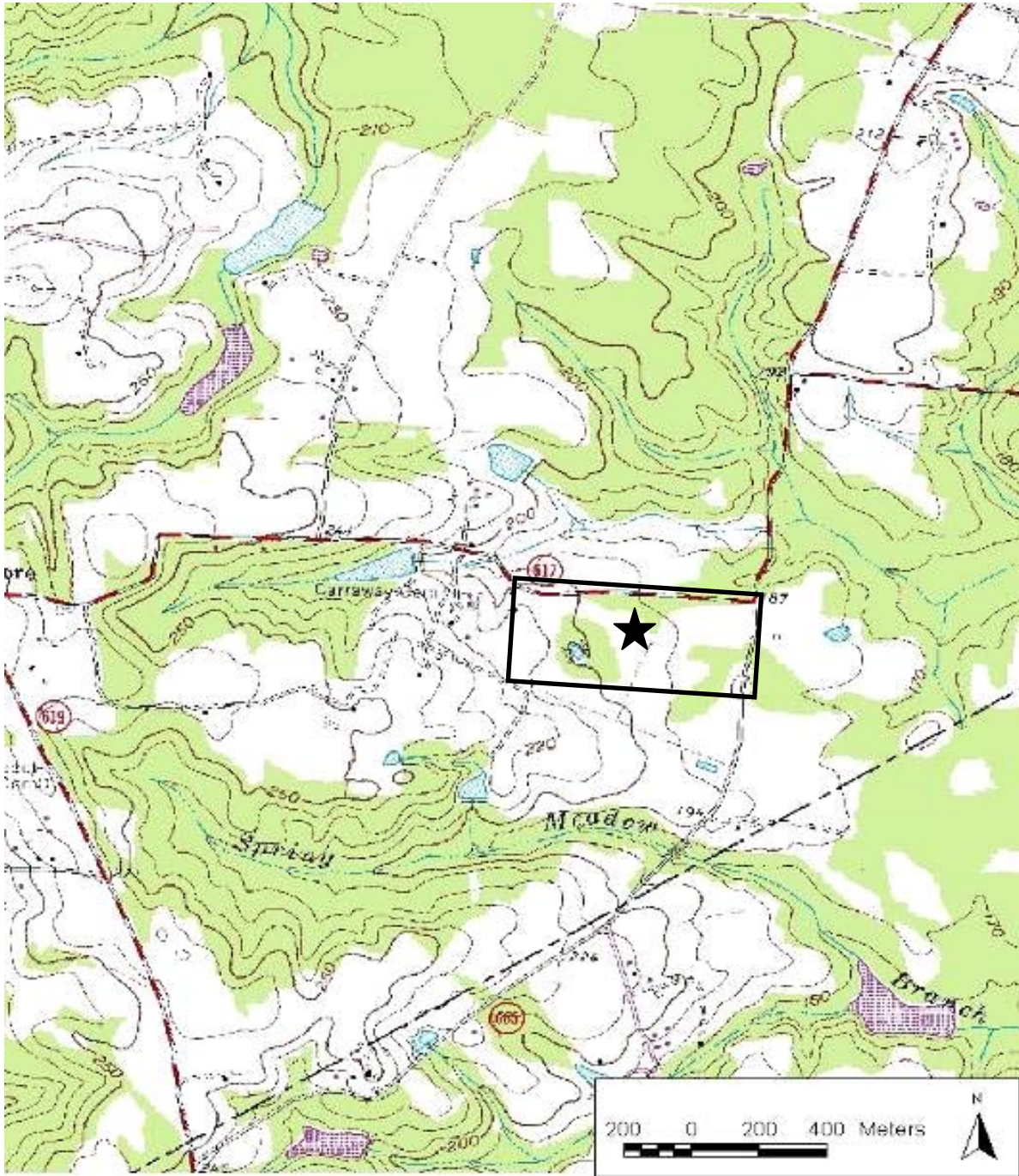

Figure 4. Topographic map of pre-mining contours of the Carraway-Winn property located on the Old Hickory Mine. Map source: USGS 7.5-minute quadrangles

2.1.1. Mining at Old Hickory

At Old Hickory, the ore is dry-mined by a track mounted backhoe with a 2.0 to 3.0 m³ bucket. The ore is then placed into a grinding machine, or mining unit, (Fig. 5) mixed with water and pumped as slurry to the wet processing facility. Please refer to Flowchart A-2, in Appendix A for Iluka's current wet mill procedures.



Figure 5. Mobile mining unit receiving ore. The ore is crushed and coarse-screened here and then pumped to the wet mill for processing. Photo courtesy of Chuck Stilson/Iluka.

Once the soil/ore slurry is in the wet mill, it is sent to a trommel screen that separates out the 'raw ore' by size. Screened ore moves to a transfer bin that transports the ore to the de-sliming cyclones. The ore is then 'de-slimed,' the process where fine, clay+silt particles are removed/cleaned from the ore, and sent to the rougher unit. From the rougher unit, the ore is

transmitted to the rougher spirals (Fig. 6) where it is separated out via gravity into three cuts; 1) tailings cut, 2) medium cut, or 3) primary cut.



Figure 6. Bank of spirals in wet mill. As the ore passes down the spirals in water, the lighter quartz and non-heavy minerals move to the outside of the spirals while the heavy minerals remain to the inside. The non-heavy mineral fraction (primarily quartz) is sent to the tailings sump to be pumped back to mine pits mixed with slimes. Photo courtesy of Chuck Stilson/Iluka.

The tailings cut, is a waste stream that consists of tailings material, which then reports to the spiral tailings sump and will be used as backfill for the mine pits. The medium cut, or ‘mids’ is a mixture of tailings, clay and ore, that is sent to the medium cleaner spiral where it is re-cleaned and separated as either tailings, or primary cut. The primary cut, is sent to the secondary spirals where the ore is re-cleaned and sent to the finisher spirals. At the finisher spirals, the ore is sent to the attritioners, or scrubber machines. From the attritioners, the ore is sent to the hydrosizers, a tank where ore is sorted again in an upward flowing water stream. Heavy/coarser

particles – heavy minerals, gravitate down and away, while lighter material is carried up and out of the hydrosizer unit and is moved to the thickener, or large vat where slimes are dewatered before they are mixed with tailings and pumped back into the pits as backfill at a mixture of 25 % to 45 % solids (Fig. 7). The slimes are flocculated with an anionic polymer in the thickener and the thickened slimes underflow is then combined with the tailings sump stream and pumped back to the mining pits as 25 to 45% solids slurry. From the hydrosizers, the ore concentrate (> 85% HM) is sent to a stacker and carried via haul trucks to the Stony Creek, Virginia, Dry Mill.



Figure 7. Thickener tank where slimes are flocculated with anionic polymers and fall to bottom where they are removed and combined with tailings to be pumped to backfill mined out pits. Clear water is decanted from the top of the thickener and returned to the wet mill. Photo courtesy of Chuck Stilson/Iluka.

2.1.2. Dry Mill Mineral Processing Procedures

At the dry mill, the ore is placed into a scrubber, sulfuric acid is added to lower overall pH ~3.5 and helps to induce Fe removal and flocculation of organic matter, and then is transported to the hydrosizer unit and separated into three categories; 1) primary, 2) mids, and 3) non-conductors. The primary cut is sent to the primary rougher, where the ore is separated out again into conductors and non conductors. Conductor cuts are further separated out into Zircon and Titanium via the use of electromagnetic and electrostatic separation. Nonconductors are sent into a scavenger unit and then sent to the Staurolite magnet where the ore is separated into three streams; 1) Mag 1, 2) Mag 2, and 3) Mag 3. Mag 2 and 3 consist of Staurolitic material and are either cleaned and placed in a Staurolite stacker or (provided they are conductive) are sent back to the conductor screen with the other conducting materials and are further separated out into titanium, zircon, or tails streams. The Mag 1 stream is sent to the conductor screen and separated (see above). The separated minerals are then shipped to the consumer and then waste non-economic minerals (dry mill tails) are returned by truck to the mine site and backfilled into mining pits (Fig. 8). Please refer to Flowchart A-3, in Appendix A for Iluka's current dry mill procedures.



Figure 8. Backfilled pit with rim ditch in place to aid dewatering. This pit will receive another layer of sandy tailings over the higher slimes material that dominate the surface shown here. Note polygonal cracking pattern in fine textured slimes as they dry. Photo courtesy of Chuck Stilson/Iluka.

2.1.3 Active Mining Pits

Mining pits, or “mining cells,” vary in size, but are typically 75 m to 200 m on a side and vary in shape from rectangular to occasionally semi-circular based on the ore configuration (Figs. 8 and 9). Berm walls or dikes are used to contain the wet tailings and slimes that are returned to the mined out pits (Fig. 10) and also as a safety buffer for each mining pit. Low-grade subsoil or saprolite material is used in dikes to increase overall size up to 4r m high.

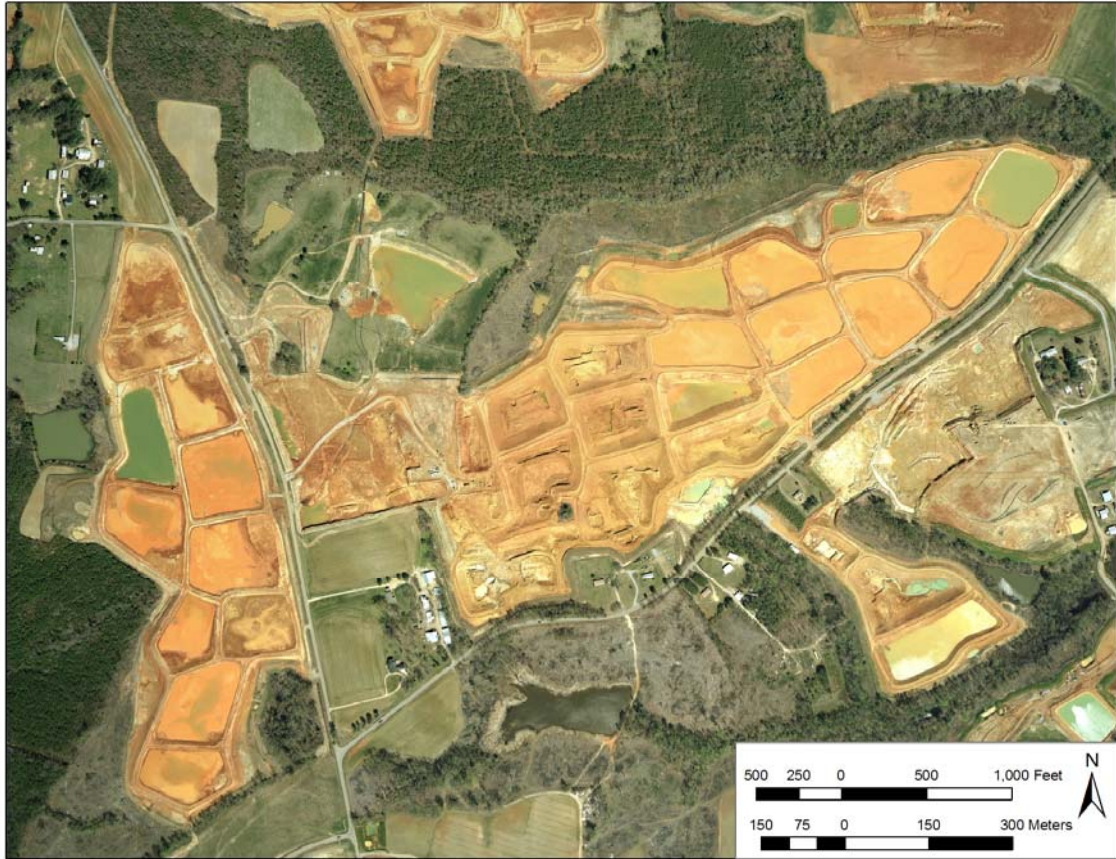

Figure 9. Aerial photo of active mining area at Old Hickory in 2006. Active mine pits are in the center of the photo while older pits to the left and right are in various phases of being backfilled with tailings. Water is decanted from pit-to-pit during the overall dewatering process. The area to the far right is being prepared for mining by topsoil removal and stockpiling.



Figure 10. Mined out pit with dike walls ready to receive tailings return. The pits in the background are in the process of settling and water decant. The topsoil berms are outside and away from the inner dike walls. Photo courtesy of Chuck Stilson/Iluka.

Generally, heavy minerals at the Old Hickory deposit are contained within the upper 5 to 20 m of highly weathered Coastal Plain soils. These Coastal Plain soils lie over Piedmont igneous and metamorphic saprolites. Because of the minerals' variability with depth, overall depths of the mining pits vary. In general, Iluka excavates only Coastal Plain sands, leaving a thin veneer of barren coarse sand over highly weathered Piedmont clay saprolites in the bottom of the mining pit (Fig. 11). The dike walls referred to above are usually constructed out of barren or low grade sands and occasionally the Piedmont saprolites.



Figure 11. Granitic saprolite with Coastal Plain cobbles and weathered soil above. This photo is from an exploration well in the northern portion of Old Hickory. Saprolites like this one underlie the mineral sands deposits at depth ranging from < 5 to > 10 m. Photo courtesy of W. L. Daniels.

Once the ore is mined and sent to the wet mill, mixed tailings (predominantly sand-sized particles) and slimes (clay, silt and some very fine sand) are pumped back into the mining pit. The company (and general Industry) collectively refers to all materials returned to the pits as “tailings.” The tailings return process is followed by a dewatering period of up to a year and then frequently by a capping of another layer of coarser textured materials (Fig. 12). Dewatering

is accomplished via the use of flash-board risers at discharge points to release only sediment free decant water and by the use of rim ditches once the surface of the tailings pack has been dewatered.



Figure 12. Backfilled pit receiving final capping of sandy tailings. Photo courtesy of Chuck Stilson/Iluka.

After capping is completed, additional dewatering may be necessary before track-hoes are used to dip and spread out any surface pockets of high slime materials (Fig. 13). Any given mining pit goes through multiple episodes of tailings return and dewatering over a period of three months to a year or more, and therefore contains many contrasting depositional layers with strongly contrasting textures.



Figure 13. Area of high slimes content being excavated and mixed by “dipping”. This process helps to homogenize the final reclamation surface with respect to soil texture. Photo courtesy of Chuck Stilson/Iluka.

Once the tailings and slimes have been adequately dewatered (a process that can take from several months to one year depending on weather conditions) and mixed, and the surface is able to support machinery, final reclamation practices are implemented. Current reclamation procedures include general grading of dewatered pits, additions of agricultural lime at 4-10 Mg/ha (depending on soil pH and texture) and P-fertilizer (350 kg/ha as P_2O_5), and a recommended sequence of V-ripping followed by chisel-plowing/offset disking (Fig. 14). Topsoil (if available) is then returned over the limed and P-fertilized tailings subsoil (Fig. 15). Where topsoil is not available, the tailings/slimes are reclaimed directly. Please refer to Fig. 16 for a summary of Iluka’s current mining and reclamation procedures.



Figure 14. Three-shank ripper being used to rip topsoil and subsoil in one pass. The ripper shanks are pulled to approximately 75 cm. For our experiment on the Carraway-Winn Reclamation Research Farm, the subsoil was ripped in two directions (90°) after the lime and P were applied. The topsoil was then returned over the ripped subsoil and loosened again with a chisel plow. Photo courtesy of Chuck Stilson/Iluka.



Figure 15. Topsoil being returned to re-graded mining pit. The topsoil will be graded out to nominal 15 cm thickness with a bulldozer. Photo courtesy of Chuck Stilson/Iluka.

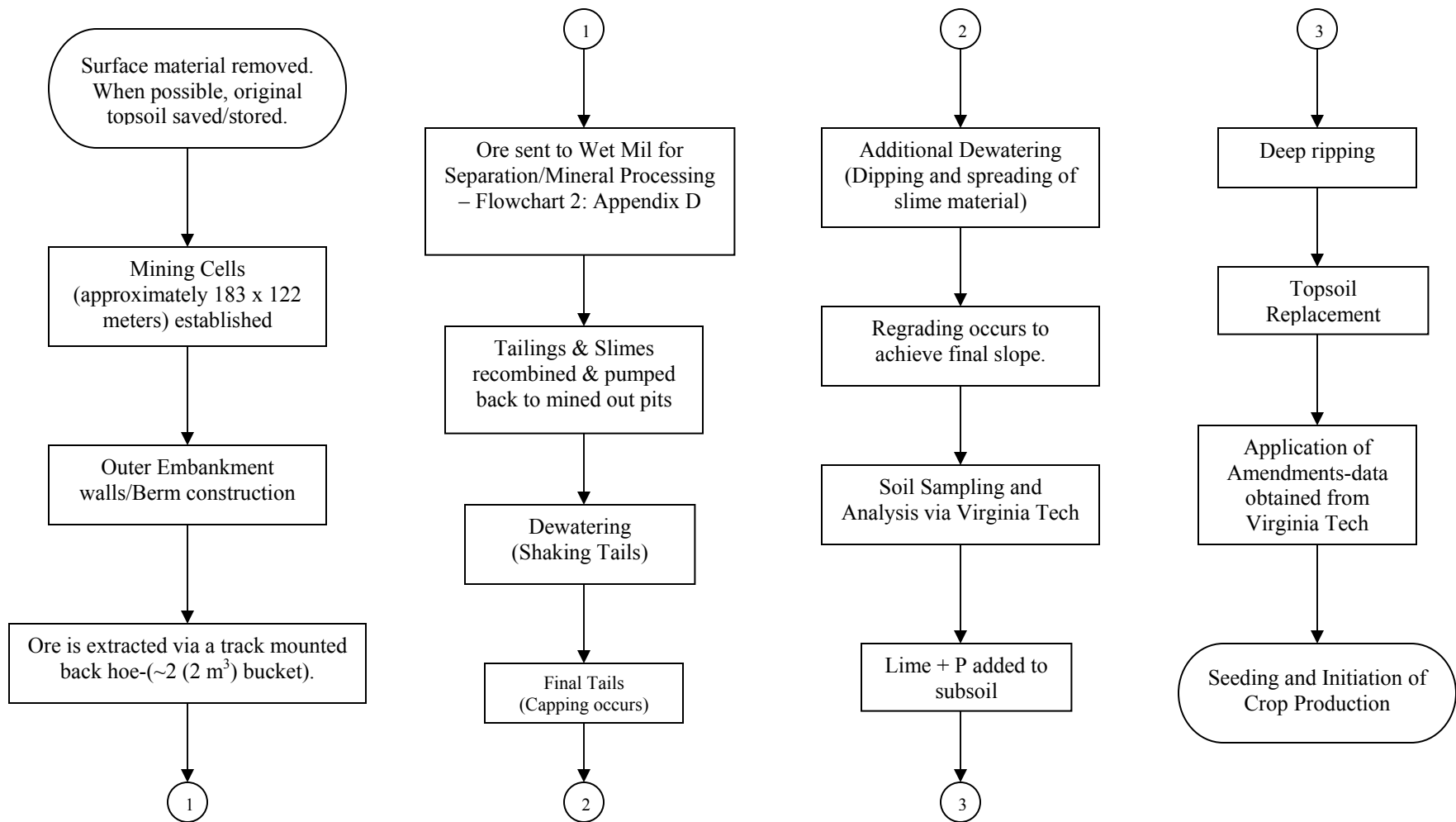

Figure 16. Flowchart of Iluka’s current mining and reclamation procedures.

2.2 Relationship of Current Experiment to Previous Mine Soil Reconstruction Trials

Active mining began at the Old Hickory deposit in the summer of 1997 as discussed earlier. Between 1989 and 1998, an extensive series of detailed soil and crop productivity mapping, wetland soil and geohydrologic, simulated tailings characterization, and reconstructed soils studies were performed (Daniels, 2003b). The soil reconstruction protocols utilized in this study were therefore based upon an extended series of greenhouse and field experiments. In the early 1990's an initial greenhouse study was conducted on simulated mine soils of varying slimes content, with and without topsoil covers. The study concluded that these simulated soils without topsoil could serve as "a suitable plant growth media" (Daniels et. al., 1996) provided that significant levels of P and lime were added.

Iluka's current mine soil reconstruction protocol (Fig. 16) is directly based upon the combined results of the studies discussed above.

These practices include (but are not limited to):

- Raking and removal of any existing vegetation.
- Removal and storage of approximately 15 cm of A horizon material (where topsoil is being salvaged) as part of the enclosing dike.
- Removal of low-grade subsoil material (where not mined) as part of the enclosing dike.
- Dry-excavation of mineral-enriched soil (using conventional mining equipment such as loaders and haulers).
- Pumping of slurried whole soil (containing mineral sands) to the wet separation mill where tailings and slimes are completely separated by cyclones and spirals

from the mineral ore. The clean tailings and slimes are then recombined for pumping back to the mined out pits.

- The pumping of tailings and thickened slimes back into the reclamation pits in a 35% to 50% solids slurry, followed by wet settling. Various measures are employed at the dewatering pits to minimize particle size segregation and hasten dewatering.
- Final grading of dewatered pits with a bulldozer to restore a final grade close to the original land surface.
- The addition of approximately 4 to 10 Mg/ha (depending on soil pH) of agricultural lime and 350 kg/ha P₂O₅ P-fertilizer, and a sequence of deep V-ripping followed by chisel-plowing and/or offset disking (Daniels, 2003b). Additional N, P and K fertilizers are added depending on the intended revegetation mixture.
- When available, the salvaged topsoil layer is reapplied over the lime+P treated tailings/slimes mixture with additional soil testing, tillage and amendments as indicated by soil test.

By the summer of 2003, it was apparent that the on-site contractor had abandoned the deep V-ripping protocol described above due to problems with rough final grades and seedbed quality due to large chunks of dried slime being pulled by the chisel-plow. Thus, between 1999 and 2003, the actual tillage package appears to have included only a shallow tine-harrow and offset disking to approximately 15 cm. However, certain pits that received biosolids in 2002 were chisel-plowed to approximately 30 cm. Beginning in 2004, all reclaimed pits have been deep

ripped with a bulldozer mounted deep (75 cm) shank ripper (Fig. 14), followed by disking to prepare the final seedbed.

2.3 Installation of Experimental Plots

In the fall of 2003, the Carraway-Winn family negotiated an agreement with Iluka Resources that dedicated approximately 40 ha of mineral sands mined land to use as a long-term demonstration research farm under the supervision of Virginia Tech. At the time of the original agreement, most of the area was still in the final phase of backfilling and regrading (Figs. 17, 18, 19). Over the spring and summer of 2004, Virginia Tech worked with Iluka to coordinate final grading of as much of the area as possible in preparation for a range of research plots and demonstrations. The experimental area chosen for this study (Fig. 17, 18, and 19) was selected based upon its relatively uniform surface soil texture and color, and a general absence of concave wet areas. The delineated area consisted of sixteen experimental plots with each plot approximately 180 m long and 15 m wide.

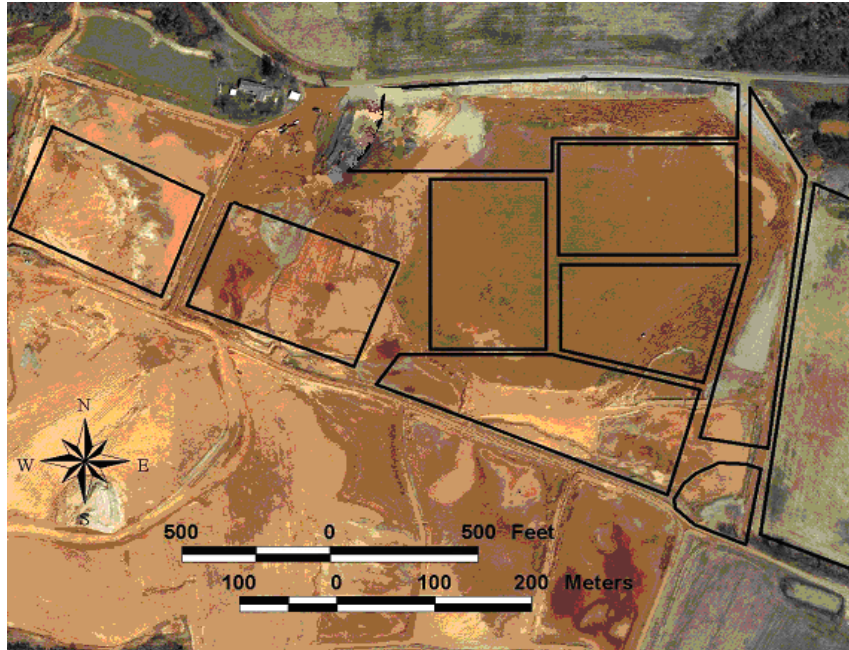

Figure 17. Aerial view of Carraway-Winn property located on the Old Hickory mine site of Iluka Resources Inc. Red and brown colors indicate high iron and clay content. This above image was taken in 2003 when the area was mid-way through final reclamation grading.



Figure 18. Aerial view of Carraway-Winn property located on the Old Hickory Mine Site of Iluka Resources Inc. This above image was taken April 2006. Row Crop plots (in right center) were planted in soybeans.

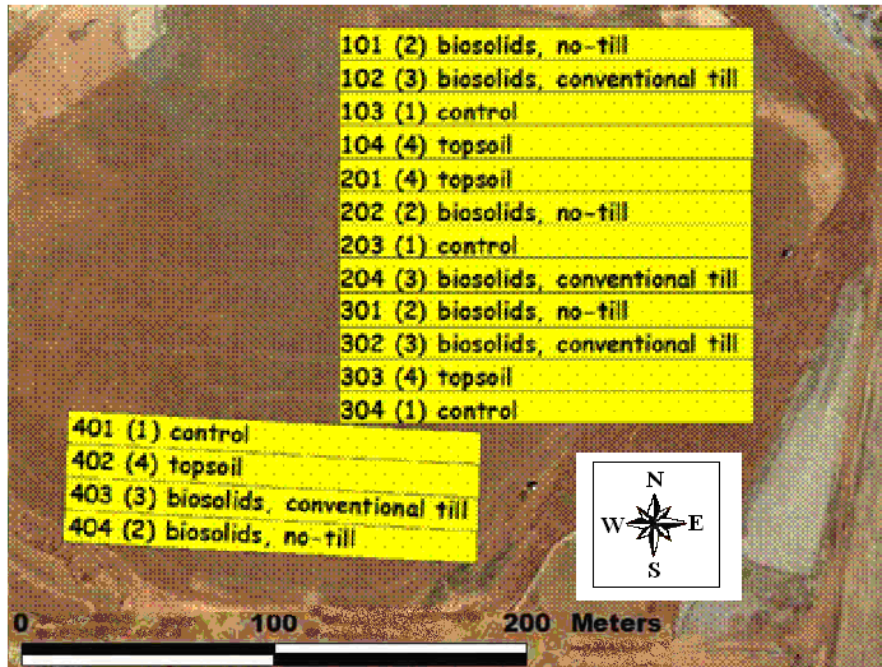

Figure 19. Diagram of soil reconstruction row crop experiment and overall plot design located on the Carraway-Winn Research Farm (CWRf) of the Old Hickory site. The blank area (upper to middle left) is compacted and serves as an external “no ripping treatment” control.

As discussed earlier, our primary objective was to evaluate the overall effects of Topsoil return vs. Biosolids amendments with appropriate tillage and fertility+lime applied to all plots. The primary row crop experiment was also compared to an external non-ripped area (Compacted Area), and an external unmined control area (Clarke Farm). The overall design was a randomized complete block with four treatments per block and four complete replications. Detail on the four main treatments is given in Section 2.3.1 below. Please note that all treatments received the same deep ripping tillage preparation.

2.3.1 Detailed Research Plot Installation

Mixed slimes (clay+silt) and tailings (sand) were pumped to the experimental area in slurry form. Once the materials particles had settled, surface water was decanted and dried, and

the surface was traversable, two D-6 Caterpillar bulldozers were used to level the fill. Each bulldozer dragged a 46-cm by 6-meter steel I-beam on its final pass to smooth its tracks. The experimental area was idle for approximately three months before the treatments were implemented. Before plots were installed, the area was covered with broadleaf weeds and annual grasses.

Final treatments were installed at the Carraway-Winn Reclamation Research Farm on September 22 and 23, 2004. The plots included four replicate blocks with four treatments per block. Each block was 59 x 183 m, with each plot measuring 15 x 183 meters. The plot width was based on the width of the agricultural equipment used by the contract farmer (Carl Clarke) and the length was set to be long enough to allow relatively routine use of that same equipment without having to stop abruptly during harvest, etc. Fig. 20 shows a diagram of one complete block of the row crop experiment and the plot layout of the various treatments studied.

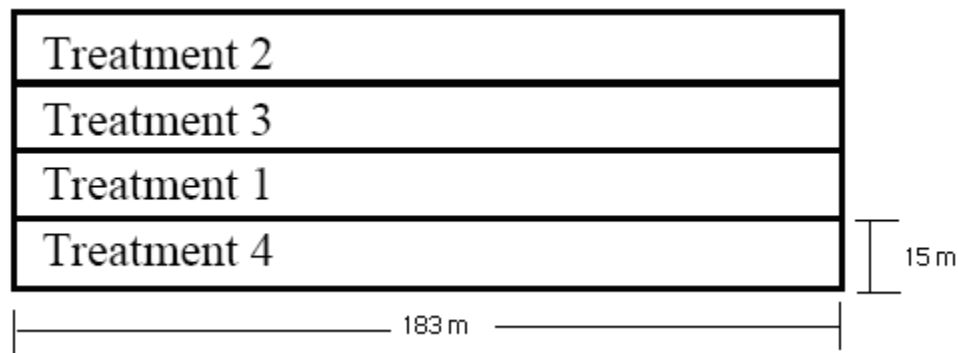

Figure 20. Diagram of one complete block of row crop experiment and plot layout.

The four main soil reconstruction treatments were as follows:

1. **Biosolids no-till:** Ripping, lime-stabilized biosolids at 78 Mg/ha in no-till management, and routine fertilization per crop management protocols.

2. **Biosolids, conventional till:** Ripping, lime-stabilized biosolids at 78 Mg/ha in conventional till for row crops, and routine fertilization per crop management protocols.
3. **Control:** Ripping, lime, P, and routine fertilization per crop management protocols.
4. **Topsoil:** Ripping, lime, P to subsoil, 15 cm of topsoil return, lime added to topsoil, and routine fertilization per crop management protocols.

A compaction study area was delineated directly adjacent to three of the treatment blocks. This area, which did not receive any treatments, is 176 m in length (adjacent to the research blocks) and approximately 49 m wide. Finally, to enable comparisons of soil characteristics and crop yields from the CWRF with that of un-mined soils, a control area was later delineated on the Clarke family farm (near the Old Hickory concentrator, approximately 1.2 km northwest from the CWRF).

On September 27, 2004, after the plots were laid out, the entire area inside the plot boundaries was sprayed with Round-Up Ultra (2.2 L/ha) and 2-4-D (1.2 L/ha) (Table B-1 in Appendix B). On October 11, 2004, all internal plot boundaries were marked with pin flags. October, 13, 2004, surface mine soil (~15 cm) was excavated from the topsoil plots with a John Deere 9520 tractor pulling an 14-m³ pan and a Bell 4206 tractor pulling a 14-m³ pan from the four plots that would receive the Topsoil return treatment. On November 3, 2004, lime (9 Mg/ha) and P (674 kg P₂O₅/ha) were applied (15 to 20-cm) to the untreated tailing surface of Topsoil (treatment 4) and Control (treatment 1) plots and incorporated with a K.M.C. chisel plow. Deep ripping with a deep multi-shank (3) ripper attachment mounted on a Caterpillar D-8 bulldozer to ~91 cm (Fig. 21) was completed in two perpendicular directions, and one subsequent pass with a chisel plow (15 to 20-cm) was made over all the plots.



Figure 21. Deep shank ripper used to cross-rip experimental plots at Old Hickory. This ripping practice is now utilized for all newly reclaimed lands at Old Hickory.

On November 10th through November 11th, 2004, topsoil was returned to the Topsoil plots with the same scraper pans. On November 17- 19, 2003, lime-stabilized biosolids, from Arlington, VA, were applied at 78 Mg/ha by Synagro Inc. by a John Deere 8520 tractor pulling a Knight 8140 Pro Twin Side Slinger agricultural spreader and incorporated to the 8 biosolids plots (Appendix C). All Biosolid treatments were incorporated with a John Deere 8520 tractor pulling a John Deere 4-m wide chisel plow followed by an off-set disk. On November 22, 2004, lime (6.7 Mg/ha) was applied and chisel-plowed and disked into the surface of the Topsoil-return plots (based on soil test data; see Table 2) to an approximate depth of 15 cm with a John Deere 8520 tractor pulling a 4-m KMC Chisel plow. Additionally, three passes of a 6-meter K.M.C. Field Cultivator pulled by a John Deere 8200 tractor were completed in the same direction over all plots. On December 31, 2004, plots were seeded with a wheat cover at 270 kg/ha. January 13, 2005, a field cultivator was used twice over all plots and buffer areas to clean off stumps and roots. On February 21, 2005, coarse roots, woody debris and other non-soil trash materials were hand-picked from all plots.

Table 2 – Soil chemical analysis of two composite topsoil stockpiles (October 2004) at the CWRP. Elemental values are acid extractable.

Pile*	location	pH	P (mg/kg)	K (mg/kg)	Ca (mg/kg)	Fe (mg/kg)
A	north	5.08	2	59	238	85
A	middle	5.10	6	63	303	112
A	south	5.17	8	89	360	117
	avg	5.12	5	70	300	105
B	north	5.70	16	92	426	129
B	middle	5.62	15	84	400	150
B	south	4.98	7	68	296	147
	avg	5.43	13	81	374	142

* Pile A was the topsoil stockpile near the road (east of the plots)

* Pile B was the topsoil stockpile in the middle of the field (west of the plots)

On April 11, 2005, the Compacted Area was disked (2 passes) and planted to corn (*Zea mays L*) (Pioneer 31G68) on the row-crop plots, the Compacted Area, and the Clarke Farm at a rate of 74,000 kernels/ha (30,000 kernels/ac). Pesticides and herbicides were applied as necessary, and the plots were irrigated throughout the summer. May 18, 2005, the corn was examined for seedling counts and height on the row-crop plots and the Clarke Farm. Seedling counts were completed by counting the number of plants that had germinated along four randomly located 15 m (50 ft) transects within each plot. For plant height, 20 seedlings were randomly selected within each plot (26 on the Clarke Farm) and measured from the ground surface to the top of the corn whirl. On July 8th, 2005, ear leaf samples were collected for tissue analysis. From each plot 10 ear leaves were randomly selected and stored in cloth bags. The samples were dried, ground and analyzed for nutrient levels.

Corn was harvested on September 9 and 10 with a John Deere 9500 combine equipped with a five row-corn head, an Ag Leader Yield Monitor and Trimble GPS unit. The yield monitor was set to take grain mass and moisture readings at 1.0 second intervals during harvest and was pre-calibrated using grain flows from 1 row to 5 rows harvested at constant ground speed. Calibration was accomplished with a "weigh wagon" equipped with electronic scales.

The five center rows of each strip were harvested to represent the "treatment" yield. Coordinates from the GPS unit were collected at the time of grain mass and moisture readings and grain yields are expressed as bushels per acre at 15% moisture. A map of yield variation within each strip was developed using Ag Leader software and Arc GIS.

Following harvest, residual corn biomass was sampled from the research farm and the Clarke Farm plots. For each plot, five samples were collected from the same locations as the previously designated soil sampling points. At each sample point, a quadrant measuring 90 X 46 cm was laid across the row (i.e. 90 cm width was perpendicular to the length of the row). All vegetation within the quadrant was cut, collected and stored in a cloth sack. The cloth sacks were placed in drying closets until weight remained constant (approximately 2 days), then weighed.

For the fall of 2005, the following methods were applied to all row-crop research areas including the row-crop plots, the compaction study area, and the Clarke plots, unless otherwise indicated. On October 5th, the Topsoil plots were chisel-plowed and disked, and the Compacted Area was disked lightly. On November 1st 2005, corn stalks in all areas were shredded. On November 3rd, crop plots were chiseled and disked (one pass), and the compaction area was lightly disked. Lime was spread at a rate of 4.5 Mg/ha (2 tons/ac) on the topsoil row-crop plots and 2.2 Mg/ha (1 ton/ac) on the Clarke plots. Dry Fertilizer (11-23-23) was applied at 393 kg/ha (350lbs/ac) on all plots. Wheat (Tribute) was planted with a Great Plains 1006NT drill at an average of 72 seeds/m (22 seeds/ft) in 19 cm (7.5 in) rows. January 30th, 2006, liquid N was applied as a 30% N solution at 187 L/ha (20 gal/ac). On March 28th, 2006, a second N application was broadcast at 140 L/ha (15 gal/ac) to all crop plots except the two Biosolid treatments and the Clarke Farm. May 14th, all areas were sprayed with 5.6 kg/ha Headline fungicide and 1.7 kg/ha Karate insecticide with a 4640 Melro spra-coupe.

Wheat was harvested June 20 and 21, 2006, with a JD9400 combine equipped with a 4.6 m (15 ft) grain table, an AgLeader Yield Monitor and Trimble GPS unit. The yield monitor was set to take grain mass and moisture readings at 1.0 second intervals during harvest and was precalibrated using grain flows from the full, $\frac{1}{2}$, and $\frac{1}{4}$ of the grain table width at constant ground speed. Calibration was accomplished with a “weigh wagon” equipped with electronic scales. The central 4.6 m (15 ft) of each strip were harvested to represent the treatment yield. Coordinates from the GPS unit were collected at the time of grain mass and moisture readings and grain yields were expressed as bushels per acre at 15% moisture. A map of yield variation within each strip was developed using Ag Leader software and Arc GIS. June 22nd, 2006, soybeans were planted with a Pioneer 94B80 to 3.8 cm deep at 101 kg/ha with a 1590 JD drill on 19 cm rows. August 6th, 2006 crop plots were sprayed with 1.6 kg/ha Roundup Weather Max using a 7210 JD tractor and an AgChem sprayer.

On November 27, 2006, 7,763 kg/ha of soybeans were harvested from the Clarke Farm and soybeans were harvested from the crop plots. Please note that the soybean harvest occurred after detailed soil and root sampling/mapping were conducted, thus it was not considered in the overall analysis of the crop plots. Refer to Appendix B for more information concerning plot maintenance and installation.

Note: For the course of this experiment both Biosolid treatments were essentially managed identically. Additionally, as discussed in Appendix B, all corn yields were irrigated. This management difference needs to be emphasized since they are compared against non-irrigated county averages later in the text.

2.3.2 Soil Sampling

After the research farm plots were laid out, but prior to any treatment or disturbance (September 23rd, 2004), soil samples were collected from all experimental plots at 30 m (100 ft) intervals along a lengthwise transect through the center of each plot. That same day, samples were collected from two topsoil stockpiles (see Table 2). This topsoil did not originate on the Carraway-Winn property and contained numerous roots and woody limbs indicative of forest soil origin. Each stockpile was divided into three sections and a composite sample was collected from each. At each sample location a surface sample (0-15 cm) and a subsoil sample (55 to 60 cm) were collected. In the laboratory, samples were air-dried, ground to pass a 10-mesh sieve, and analyzed for pH, organic matter and analyzed for pH in a 1:1 soil to water slurry (Thomas, 1996). Exchangeable levels of P, K, Ca, Mg, Zn, Cu, Fe and B by an Inductively Coupled Plasma Emission Spectroscopy (ICPES) were also documented (Donohue and Heckendorn, 1996). All samples were sent to the Virginia Tech Soil Testing Laboratory initially in 2004. Detailed soil chemical properties are given in Table D-1 located in Appendix D.

Over the summer of 2005 (May 31st – September 16th), the entire soil reconstruction research plot array was sampled again. This first-order soil sampling consisted of auger transects. A minimum of five equally spaced auger borings were made within each plot. All borings were spaced at approximately 35 m apart down the plot center line, and were carefully described and sampled for; 1) extractable nutrients and metals, 2), total C and N with an Elementar[™] elemental analyzer, 3), particle size analysis (USDA-NRCS, 2004) 4) horizon morphology (USDA-NRCS, 2004), and 5) rooting depth and abundance (USDA-NRCS, 2004). Borings were made to a minimum depth of 2 m with composite samples taken every 25 cm.

Additional bulk samples of defined horizons were also collected. Detailed physical/chemical data are found in Appendix E and auger profile descriptions are found in Appendix F.

An auger head core ring sampler designed by Stolt et al., (1991) was used to obtain a subsoil bulk density sample. Approximately three borings were taken at each sample node. Samples were placed in an oven at 105° C and dried overnight. Bulk density was averaged over the three sample cores taken at each sample node.

February 22nd, 2006, a Dicky-John Auburn soil penetrometer was used to estimate soil strength (psi). The rod was driven into the soil at a constant rate until it reached approximately 15 cm. There are two tip sizes, 1 cm and 2 cm. Readings were recorded from the 2-cm range using the 1-cm tip and thus had to be converted before any statistical analyses were run. A second sample was taken at approximately 20-cm.

Detailed soil pit sampling was performed following wheat harvest between June 29th and August 10th 2006. One pit location within each treatment plot was selected based on an overall analysis of the data collected from the auger borings. Representative samples of each plot were chosen based on the following:

- Overall Soil Texture - Depth of each horizon was weighted against texture in order to determine an overall texture for each of the five sample profiles. A representative profile had this overall texture.
- Any profiles missing key horizons--i.e. horizons containing significant clays or sands, were thrown out of the decision making procedure.
- Number of horizons determined within the soil profile - Profiles with less than an average number of horizons were thrown out of the decision making procedure.

- Soil Color - Repeating colors--i.e. specifically reds and strong browns, were also considered for representative sample pit locations.
- Additional notes - Any additional notes or discrepancies within each horizon were considered. For example if one horizon had a considerable amount of organic matter and the other horizons of various sample pit locations did not, then that horizon was treated as an anomaly and the soil profile was no longer considered during the decision making procedure.
- Number of roots - The number of roots was determined from the end of the first three to five auger buckets of each soil profile.

Pits were located via the use of a handheld Garmin GPS12 and accuracy was approximately 1 to 5 meters. Please note that there is an accuracy error associated with handheld GPS units and this error was particularly observed in the southern portion of the plots. According to the handheld GPS unit, CWRF 403-5 was located a few feet inside plot 404 and CWRF 404-1 was located outside of the treatment area. To correct for this, we used a measuring tape to locate the last two soil pits.

Pits were oriented in such a way to hopefully expose the effects of the deep cross ripping (if evident). Detailed morphological descriptions were made along the western pit face of each soil pit (Soil Survey Staff, 1993). Density analyses of individual horizons were estimated via bulk density core sampling (USDA-NRCS, 2004). Overall rooting abundance and orientation was observed using standard NRCS Soil Survey Division criteria (Soil Survey Staff, 1993). In the laboratory, samples were air-dried, ground to pass a 2-mm sieve. In the laboratory, samples were air-dried, ground to pass a 10-mesh sieve, and analyzed for pH, total C, and analyzed for pH in a 1:1 soil to water slurry (Thomas, 1996). Exchangeable levels of P, K, Ca, Mg, Zn, Cu,

Fe and B by an Inductively Coupled Plasma Emission Spectroscopy (ICPES) were also documented (Donohue and Heckendorn, 1996) in the Virginia Tech Soil Testing Laboratory. Physical/chemical data are found in Appendix G and detailed pit descriptions are given in Appendix H.

One wall of each pit also received a detailed rooting assessment using an interpretation of Böhm's (1979) profile wall technique. This method consisted of digging pit faces, perpendicular to the row crop, and smoothing them with a soil spade. The pit face was then framed with an 8.5 x 11 cm transparent plastic sheet per horizon with a 1 decimeter, 10 x 10 cm, square block in the center. Rooting positions were mapped on this film cover with assorted color markers to distinguish dissimilar root sizes. Although Schroeder (1997) used a similar approach in his earlier M.S. thesis work at Old Hickory, his method focused on the whole pit face and not a small subsection as mine did. Analysis of plant rooting depth and distribution allowed us to better understand the impact that high bulk densities, caused by excessive soil compaction had on rooting depth as compared to crop productivity.

In the laboratory, ten samples were taken from bulk soil samples from the 20 soil pits sampled over the summer of 2006 and analyzed for D_p , or particle density (Blake, 1965). Please note that heavy mineral sands have a high specific gravity and can increase a soil's particle density and particle density can directly influence a soil's bulk density. Given that the heavy minerals found in heavy mineral sands occur in sandy soils, samples were chosen based on overall soil texture--i.e sandier soils with higher bulk densities. Additionally, the presence of organic matter can lower a soil's particle density, thus lowering its bulk density. We decided to contrast the sandy samples with samples located under or in buried A horizons for comparative purposes only.

2.4 Overall Statistical Design and Analysis

The primary row crop soil reconstruction experiment was designed and analyzed as a randomized complete block design with four replications. Data for soil parameters such as pH, organic matter and D_b varied in the number of observations taken within each plot, however, a minimum of three observations were made for all tested parameters per plot ($n \geq 3$ per plot). A combination of descriptive statistics and the SAS (2004) was used to determine if there were significant block vs. treatment interactions and overall treatment effects. Given the fact that all important data parameters followed normal or near-normal distributions, a conventional ANOVA approach with mean separations via Fisher's protected LSD test was utilized. Overall ANOVA ($n \geq 4$ per treatment) and subsequent mean separations were considered significant at $P \leq 0.05$ unless noted otherwise. For contrasts involving differences in soil properties with depth in a given treatment, a paired t-test approach was utilized for mean separations.

Additionally, two sample t-test contrasts were used to compare yield and soil data from the Clarke Farm and the Compacted Area against individual treatments within the row crop soil reconstruction experiment. This was necessitated because these two areas were not part of the overall row crop experimental design, but I felt that it was important to offer some means of comparing these properties.

III. RESULTS AND DISCUSSION

3.1 Mine Soil Properties Observed from Auger Profiles

3.1.1 Auger Profile Summary

The mine soils described from the 124 auger profiles were highly variable. The most common horizon sequences were ^Ap-^C1-^C2 (56 profiles), ^Ap1-^Ap2-^C (30 profiles),

Nineteen of the 124 profiles exhibited densic (e.g. limiting to root penetration except in desiccation cracks) properties and seven profiles contained significant buried A horizons. One pedogenically developed subsoil horizons (Bw) was observed in auger boring 103-2, a Control treatment. Twenty-seven profiles came in contact with the water table and seven exhibited a moderate musty sulfur odor. All profiles were classified by Soil Taxonomy (Soil Survey Staff, 2006) into a range of Entisol and Inceptisol taxons as detailed later. In addition to the 104 profiles sampled within the Carraway-Winn Reclamation Research Farm (CWRF) (80) and the Compacted Area (24), 20 profiles were sampled at an off-site control area at the Clarke farm (see Mine Soil Properties section 3.1.2). Detailed soil descriptions are found in Appendix F and chemical/physical data in Appendix E.

3.1.2 Mine Soil Properties

3.1.2.1 Soil Color

Overall Ap soil matrix colors ranged from yellowish brown (10YR 4/4) to strong brown (7.5YR 4/6) to red (5YR 4/4) to olive brown (2.5Y 4/3) with the bulk of matrix colors appearing as strong brown (7.5YR 4/6) and olive brown (2.5Y 4/3). Subsoil matrix colors ranged from dusky red (2.5YR 4/2) to brown (7.5YR 4/4) to yellow (10YR 8/6) to dark olive brown (2.5Y 3/3), with the bulk of matrix colors appearing as strong brown (7.5YR 5/6), followed by brownish yellow (10YR 6/6). These colors and associated horizon morphologies are also depicted later in section 3.6. Depth of plow layers (Ap horizons) ranged from 5 to 15 cm with Bio-CT at an average depth of 13 cm, Bio-NT at an average depth of 16 cm, Topsoil at an average depth of 16 cm, and Control at an average depth of 12 cm (Table 3).

Table 3 – Mean depth of the plow layer (Ap) by treatment at the Carraway-Winn Reclamation Research Farm (Summer 2005). Depths based on auger descriptions found in Appendix F. Values within columns followed by the same letter are not different ($p \leq 0.05$).

Treatment	Mean depth to plow layer (cm)
Bio-CT	13a
Bio-NT	16a
Control	12a
Topsoil	16a

The Ap matrix color for the Compacted Area ranged from dark brown (7.5YR 4/4) to yellowish brown (10YR 4/4) with the bulk of matrix colors occurring as strong brown (7.5YR 4/6). Subsoil matrix colors ranged from dark red (2.5YR 4/6) to light olive brown (2.5Y 5/6), with the bulk of matrix colors appearing as a strong brown (7.5YR 4/6) and dark yellowish brown (10YR 4/4). The average depth of the Ap horizon was 14 cm with an average depth to observable rooting of 62 cm.

At the Clarke Farm, overall surface soil color was olive brown (2.5Y 4/4 and 2.5Y 4/3) with the bulk of matrix colors appearing as (2.5Y 4/4). Subsurface soil colors ranged from dark red (2.5YR 3/6) to olive brown (2.5Y 4/4) with the bulk of matrix colors appearing as olive brown (2.5Y 4/4) and strong brown (7.5YR 4/6).

3.2. Soil Physical Properties

Particle size analyses for the auger study were performed on 0-15 cm composite surface samples only (Tables E-1, E-2, and E-3 in Appendix E). Of the 80 CWRP soils, 43 were sandy loam, 27 were sandy clay loams, one was sand, seven were sandy clay loam/sandy loam, and two were loamy sands. Of the 24 samples tested in the Compacted Area, 18 were sandy loam, four were sandy clay loam and two were sandy clay loam/sandy loam. Of the 20 samples tested on

the Clarke farm, 18 were sandy loams, and two were sandy loams/loamy sands. The majority of sandy surface soil textures occurred in the southernmost plots (401, 402, 403, and 404), due to a concentration of sandy tailings in that area. Considering that an auger was used to extract profiles and it destroys ped form, we did not assess soil structure.

Dense compacted layers, or layers exhibiting one or more densic properties, were observed in at least 15 of the 80 CWRP profiles. Although these layers exhibited densic properties they were not classified as true 'densic' layers. Of these 15 profiles, 8 were observed in the northern end of the plots at 101, 102, 103 and 104, two were observed in plots 201 and 203, three were observed in plots 302 and 303, and four were observed in plots 401 and 402 (Table 4). Densic layers, or layers that were determined to be true 'densic' layers--i.e. layers that are completely root limiting, were observed in seven of the 80 CWRP profiles; Control (3), Bio-NT (1), Bio-CT (1), and Topsoil (1). Buried A horizons were found in auger borings 101-1, 102-1, 103-1, and 103-2. Additionally, the vast majority of profiles were either approaching or were saturated approximately 1-m depth from the surface, and free water was observed in auger borings 201-5, 203-5, 204-4, 204-5, 301-3, 301-5, 302-4, 303-2, 303-3, 304-2, 304-3, 304-5, 403-2, 403-3, 403-5, 404-3, and 404-5 (Table 4) at depths ranging from 69 cm to 125 cm.

Table 4 – Occurrence of buried A horizons, densic properties and observed water tables from auger borings.

	Plot ID	Treatment Type	Number of Profiles for Feature Observed
Buried A Horizon	101-1, 102-1, 103-1, 103-2, EC 3-2, EC 1-2, EC 5-1	101 – Bio NT 102 – Bio CT 103 - Control EC – Compacted Area	Bio NT – 1 Bio CT – 1 Control – 2 Compacted Area – 3
Densic Properties	101-2, 101-4, 102-3, 102-4, 102-5, 103-2, 103-3, 104-4, 201-3, 203-3, 302-1, 302-5, 303-3, 401-1, 402-1, 402-2, 402-4, EC 11-1, EC 11-2	101 – Bio NT 102 – Bio CT 103 – Control 104 – Topsoil 201 – Topsoil 203 – Control 302 – Bio CT 303 – Topsoil 401 – Control 402 – Topsoil EC – Compacted Area	Bio NT – 2 Bio CT – 5 Control – 4 Topsoil – 4 Compacted Area – 2
Densic Layers	102-2, 103-5, 201-5, 203-2, 204-2, 301-4, 304-3	102 – Bio CT 103 – Control 201 – Topsoil 203 – Control 204 – Bio CT 301 – Bio NT 304 – Control	Bio NT – 1 Bio CT – 2 Control – 3 Topsoil – 1
Water Table within 130 cm or less.	201-5, 202-5, 203-2, 203-5, 204-3, 204-4, 204-5, 301-3, 301-4, 301-5, 302-4, 303-3, 303-4, 303-5, 304-2, 304-3, 304-4, 304-5, 401-1, 401-2, 401-3, 403-2, 403-3, 403-5, 404-1, 404-3, 404-5	201 – Topsoil 202 – Bio NT 203 - Control 204 – Bio CT 301 – Bio NT 302 – Bio CT 303 – Topsoil 304 – Control 401 – Control 403 – Bio CT 404 – Bio NT	Bio NT – 7 Bio CT – 7 Topsoil – 4 Control – 9

True densic layers were observed in none of the Compacted Area profiles; however, layers with densic properties were observed in EC 11-1 and EC 11-2, located near adjacent CWRP plot 303 (Topsoil). Buried A horizons (Ab) were found in EC 1-2, EC 3-2, and EC 5-1, located near adjacent CWRP plots 101, 104 and 201 (Bio-NT, Topsoil and Topsoil treatments, respectively). None of the Compacted Area profiles came in contact with the water table; however, a few had a ponded surface during sampling, presumably due to underlying densic

layers producing periodic episaturation. No densic layers or buried A horizons were observed at the Clarke farm offsite control.

3.2.3 Soil Texture/Clay Content

Surface soil clay contents (20%) were higher in the Bio-CT, Bio-NT, and Control treatments than the Topsoil plots (15%) (Table 5). The first three treatments were comprised of re-graded tailings+slimes while the Topsoil return plots contained more of the pre-mine A+E horizons content. The minimum clay content across all four treatments was 6% and occurred in a Control treatment boring. The maximum clay content across all four treatments was 32% and occurred in a Bio-CT boring. There were no treatment, block, or block*treatment interaction effects for surface clay content. The variance estimator (S.D.) also indicates that the reconstructed tailings+slimes soils were more variable from point to point than the returned Topsoil, and the Clarke Farm samples.

Table 5 – Mean clay content (0 to 15 cm) by treatment at the Carraway-Winn Reclamation Research Farm (Summer 2005) and external comparison plots. Values within columns followed by the same letter are not different ($p \leq 0.05$).

Treatment	Mean Clay Content (%)	Standard Deviation
Bio-CT	20a	5
Bio-NT	20a	5
Control	20a	6
Topsoil	15b	2
Clarke Farm	8	2
Compacted Area	17	3

3.2.2 Surface Bulk Density

Surface bulk density samples (D_b), were taken approximately 7 cm below the soil surface near each auger boring (within 60 cm laterally). There was a significant treatment effect ($p < 0.01$) for surface bulk density with the Control plots significantly higher than the Bio-NT treatment ($p < 0.03$) (Table 6). The average surface bulk density for the Clarke Farm and the Compacted Area was 1.73 g/cm^3 and 1.75 g/cm^3 respectively. Individual contrast statements indicated the Clarke Farm was not significantly different than any of the four CWRP soil reconstruction treatments, nor was it significantly different from the Compacted Area.

Table 6 – Mean surface bulk densities for the Carraway-Winn Reclamation Research Farm (Summer 2005). Values within columns followed by the same letter are not different ($p \leq 0.05$).

Treatment	Mean Surface D_b (g/cm^3)	Standard Deviation
Bio-CT	1.73ab	0.11
Bio-NT	1.71b	0.11
Control	1.78a	0.14
Topsoil	1.73ab	0.11
Clarke Farm	1.73	0.09
Compacted Area	1.75	0.10

Typical limits of a normal soil range for mineral soil bulk density vary between 2.0 g/cm^3 for highly compacted soils and 1.0 g/cm^3 for well aggregated humus rich soils. Although, there were no D_b values significantly greater than 2.0 g/cm^3 or less than 1.0 g/cm^3 observed, a few D_b values were slightly higher than 2.0 g/cm^3 ; samples 102-3 and 103-4 and C1-5 at 2.01 g/cm^3 , 2.01 g/cm^3 and 2.04 g/cm^3 respectively.

A significant block*treatment interaction ($p < 0.01$) was observed. Figure 22 displays the overall block*treatment effects for mean bulk densities at the CWRP. There is a significant block effect for all four soil reconstruction treatments within block three. Treatments two and

three (Bio-NT and Control respectively) had significantly higher surface bulk densities than the Bio-CT and Topsoil treatments for block four. Additionally, we can see that the Control treatment had both the lowest and the highest average surface bulk density based on block location.

Figure 22 – Plot of surface (7+ cm) bulk density (g/cm^3) taken at 7-cm block*treatment interaction effects for samples from the Carraway-Winn Reclamation Research Farm in summer of 2005.

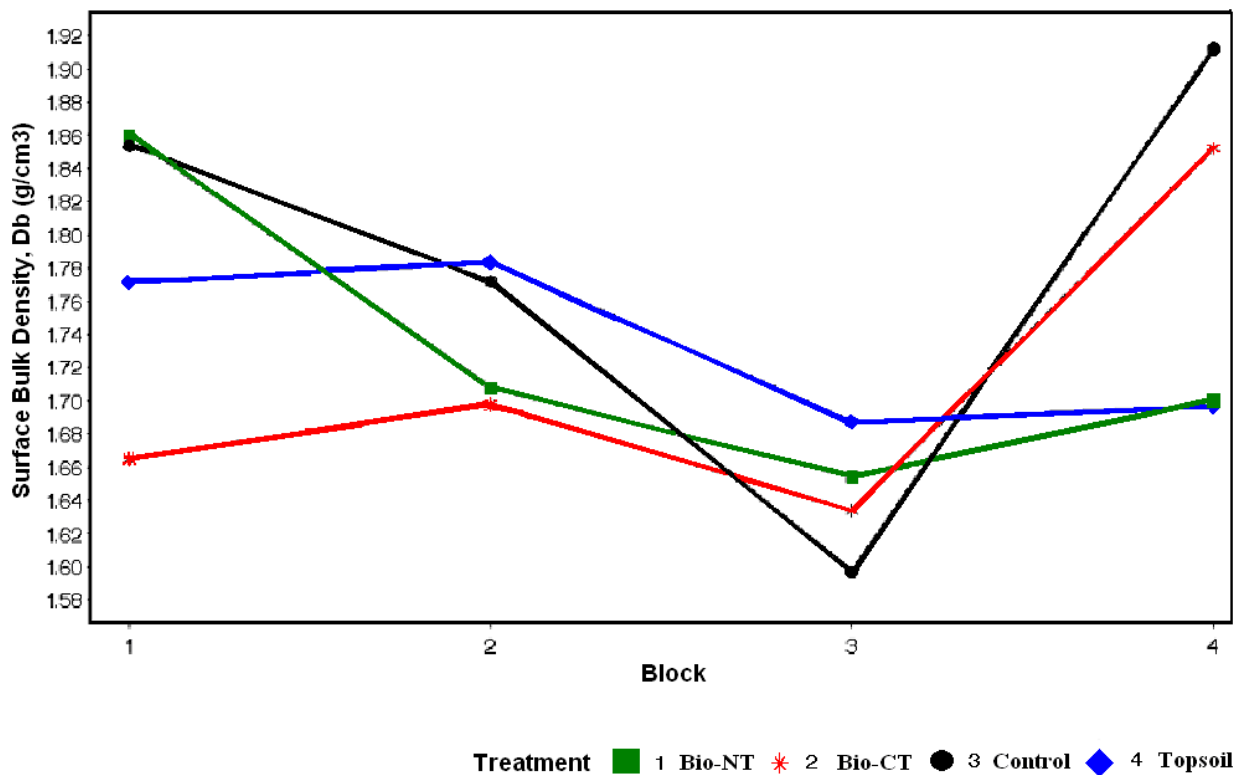

Table 7 reports the range and incremental distribution of surface soil texture and bulk density observed across the study area. Of the 80 samples analyzed, 10 had a $D_b \geq 1.5 \text{ g/cm}^3 < 1.6 \text{ g/cm}^3$, 22 had a $D_b \geq 1.6 \text{ g/cm}^3 < 1.7 \text{ g/cm}^3$, 22 had a $D_b \geq 1.7 \text{ g/cm}^3 < 1.8 \text{ g/cm}^3$, 17 had a $D_b \geq 1.8 \text{ g/cm}^3 < 1.9 \text{ g/cm}^3$, seven had a $D_b \geq 1.9 \text{ g/cm}^3 < 2.0 \text{ g/cm}^3$ and two had a $D_b \geq 2.0 \text{ g/cm}^3$. Because there appeared to be a rough correlation between treatment and surface texture, I

conducted a correlation analysis among % sand, D_b , and total rooting depth. There was a weak correlation ($0.31 - p < 0.0049$) between % sand and D_b , and a weaker correlation (-0.24) between total depth to rooting and % sand. This was most likely due to the interaction of texture and particle packing on bulk density assuming similar compactive effort. Additionally, Table 7 confirms that higher bulk densities occurred more often in Topsoil treatments and that lower bulk densities occurred more often in Bio-NT treatments. Higher bulk densities within the Topsoil treatment are most likely a result of mechanical compaction or deep ripping while the soil is wet.

Table 7 – Comparison of soil texture with surface bulk density for Carraway-Winn Reclamation Research Farm samples collected over the Summer of 2005.

Bulk Density D_b (g/cm^3)	Soil Texture	Treatment	Sample Number
$\geq 2.0 \text{ g}/\text{cm}^3$	SL – 1 SCL – 1	Control – 1 Bio-CT – 1	103-4, 102-3
$\geq 1.9 \text{ g}/\text{cm}^3 < 2.0 \text{ g}/\text{cm}^3$	SL – 7	Topsoil – 7	303-2, 402-4, 303-4, 303-3, 104-3, 201-1, 303-5
$\geq 1.8 \text{ g}/\text{cm}^3 < 1.9 \text{ g}/\text{cm}^3$	SL – 14 SCL – 2 SCL/SL – 1	Topsoil – 7 Control – 5 Bio-CT – 4 Bio-NT – 1	402-5, 201-2, 201-4, 203-2, 103-3, 102-1, 102-4, 402-3, 303-1, 302-3, 103-2, 103-1, 102-2, 402-2, 104-5, 202-1, 203-1
$\geq 1.7 \text{ g}/\text{cm}^3 < 1.8 \text{ g}/\text{cm}^3$	SL – 9 SCL – 7 SCL/SL – 4 LS – 2	Topsoil – 3 Control – 7 Bio-CT – 8 Bio-NT – 4	401-4, 402-1, 401-1, 403-2, 304-4, 203-3, 104-2, 101-2, 403-3, 102-5, 302-4, 302-5, 104-1, 203-5, 304-2, 403-4, 101-1, 204-5, 103-5, 301-4, 202-5, 204-2
$\geq 1.6 \text{ g}/\text{cm}^3 < 1.7 \text{ g}/\text{cm}^3$	SL – 9 SCL – 11 SCL/SL – 1 S – 1	Topsoil – 2 Control – 6 Bio-CT – 3 Bio-NT – 11	304-5, 401-3, 304-3, 204-1, 203-4, 403-5, 301-3, 101-4, 301-5, 202-4, 404-4, 201-5, 202-2, 202-3, 404-5, 404-2, 104-4, 401-2, 401-5, 301-1, 301-2, 403-1
$\geq 1.5 \text{ g}/\text{cm}^3 < 1.6 \text{ g}/\text{cm}^3$	SL – 3 SCL – 6 SCL/SL – 1	Topsoil – 1 Control – 1 Bio-CT – 4 Bio-NT – 4	101-3, 201-3, 304-1, 302-1, 101-5, 302-2, 204-3, 404-3, 204-4, 404-1

Due to our frequent observance of visible mineral sands (which have a much higher particle density than other soil minerals) in many horizons, we were concerned that true particle densities would be higher than the standard presumption of 2.65, which would greatly

complicate interpretation of bulk density. However, the majority of a subset of soils tested (n = 10) had a D_p between 2.60 to 2.75 g/cm³ which was unaffected by soil texture. Table 8 presents the average particle density for this subset of soil samples taken from soil pits on the CWRF over the summer of 2006. Overall, particle density fell within typical limits with the exception of sample 103-2, a control treatment with a D_p of 2.76 g/cm³ which was only marginally higher than the rest of the sample set. Therefore, we assumed that our measured bulk density values were not adversely affected by abnormally high particle densities.

Table 8 – Average particle density for a representative set of samples taken from soil pits for the Carraway-Winn Reclamation Research Farm (Summer 2006).

Treatment	Sample ID	Particle Density (g/cm ³)
Topsoil	104-5 (0-7cm)	2.68
Topsoil	201-2 (0-10cm)	2.75
Topsoil	303-2 (0-12cm)	2.72
Topsoil	402-3 (0-8cm)	2.73
Bio-NT	301-3 (64-97cm)	2.67
Bio-CT	102-3 (82-120cm)	2.74
Control	103-2 (86-130+cm)	2.72
Control	304-1 (100-130+cm)	2.67
Bio-CT	102-3 (10-36cm)	2.62
Control	103-2 (5-46cm)	2.76

Linear regression was used to compare surface bulk density data with corn and wheat yields as estimated by the GPS receiver and yield monitor data set on the harvest combine. Linear, quadratic and cubic models all generated low R^2 values (< 0.1) for both corn and wheat point yield estimates vs. nearest bulk density. Low R^2 values are most likely a result of: 1) the fact that the GPS units used during harvest and sample collections were not of the same caliber-- handheld vs. vehicle mounted; 2) poor accuracy of the GPS units, or perhaps 3), there really was

no consistent relationship between surface bulk density and corn and wheat yields. However, it is more likely that the different GPS units were the chief factor of poor correlation.

3.2.3 Soil Strength/Penetrometer Measurements

Soil strength, or the measurement of the soil’s ability to withstand point penetration and failure--i.e. fracture, rupture, etc., is an important approach to estimate a soil’s ability to readily allow root penetration. Soil strength measurements were taken for the CWRP in February of 2007 using a Dickey-John penetrometer (Table 9) at depths of 15 and 31 cm at 5 locations within each treatment plot (16 plots total). For the purposes of this paper, we looked at both soil strength and bulk density to see if there were significant correlations with the data, and if high bulk density and high penetrometer resistance did indeed inhibit crop yield and overall rooting.

Table 9 – Average surface and subsurface soil strength for the Carraway-Winn Reclamation Research Farm (Spring 2007) as estimated with a penetrometer. Values within columns followed by the same letter are not different ($p \leq 0.05$).

Treatment	Mean Surface (15 cm) Soil Strength (kPa)	Mean Surface Soil Strength (psi)	Mean Subsurface (30 cm) Soil Strength (kPa)	Mean Subsurface Soil Strength (psi)
Bio-CT	1372a	199a	2979b	432b
Bio-NT	1379a	200a	3068b	445b
Control	1338a	194a	3861a	560a
Topsoil	1407a	204a	3710a	538a

For surface soil strength values, there was a significant treatment effect ($p < 0.0008$) and a significant block*treatment ($p < 0.0001$) interaction. Subsurface soil strength values had both a significant treatment effect ($p < 0.007$) and a significant block*treatment interaction ($p < 0.025$).

Figure 23 – Plot of penetrometer means (psi) showing block*treatment interaction for subsurface soil samples (30 cm) at the Carraway-Winn Reclamation Research Farm. Samples were taken over February 2006.

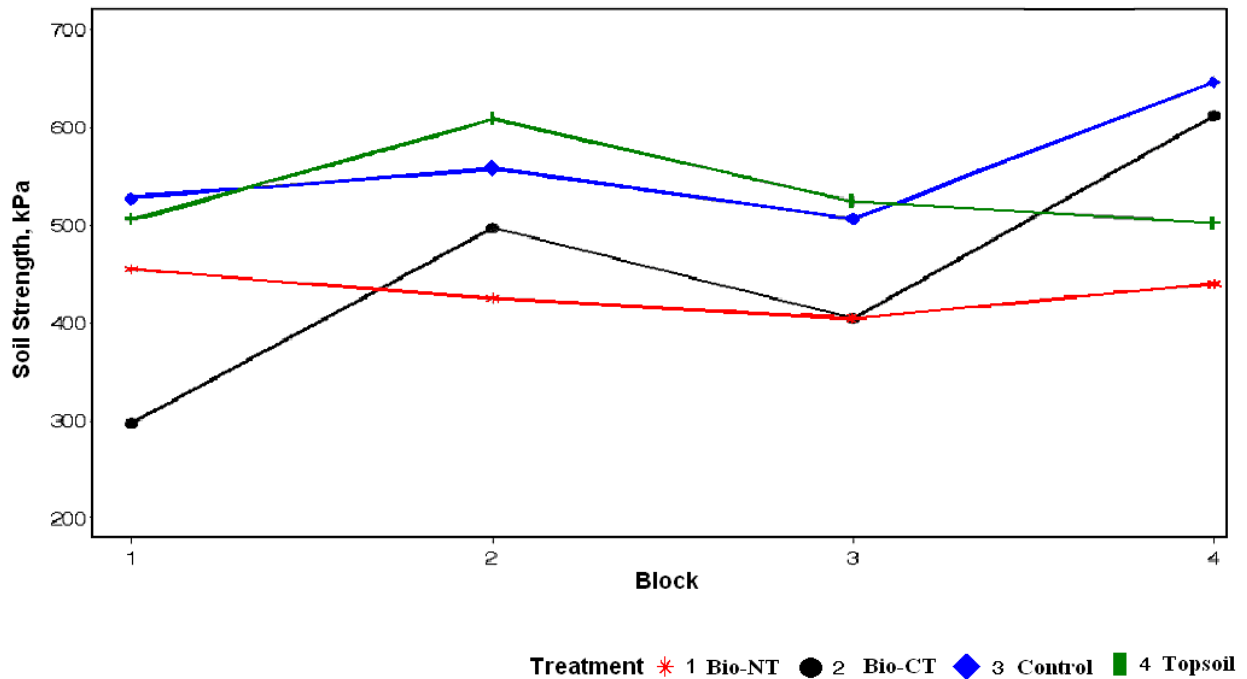

Figure 23 shows that the Bio-NT treatment did not vary across the four blocks (Fig. 23). Overall, the Control and Topsoil treatments were higher in soil strength than the two Biosolids treatments. However, the Bio-NT and Control treatments exhibited the highest subsurface soil strength in Block 4, while the Bio-NT treatment exhibited the lowest subsurface soil strength in Block 1.

Linear regression was also used to relate penetrometer data with corn and wheat yields. Linear, quadratic and cubic models again produced low R^2 values (< 0.1) for both surface and subsurface soil strength vs. yield for all three models. Please note that penetrometer data was taken in early February (2007) and soil moisture status was not measured, so we cannot assume that all treatments were similar in soil moisture. Therefore, the low correlation between crop yield and soil strength may be a direct result of sample collection time. Additionally, Thompson

et al. (1987) determined that penetrometer resistance and bulk density were highly correlated within the lower root zone only. Therefore, those factors affecting bulk density (Section 3.2) may also have attributed to low R^2 values between crop yields and soil strength.

3.3 Soil Chemical Properties

3.3.1 Soil pH in 2005

Surface and subsurface pH values for all four reconstruction treatments, the Clarke Farm offsite control and the Compacted Area are shown in Table 10. The two Biosolids treatments (Bio-NT and CT) had the highest surface pH (7.21 and 7.10), which were significantly greater than the Control ($p < 0.0003$) at 6.51. The Topsoil treatment had the most acidic surface pH (5.68) despite the prescribed application of 9 Mg/ha lime in the Fall of 2004.

Subsurface pH values were more acidic than surface values due to a lack of liming effect at depth. Bio-CT, Bio-NT, and Topsoil treatments had similar subsurface pH values of 5.05, 5.01, and 5.00 respectively. The Control treatment had the most acidic subsurface pH at 4.82. Overall, the Clarke Farm samples were strongly acidic to mildly basic with pH values ranging from 4.66 to 6.63, with average surface and subsurface pH values of 5.82 and 5.86 respectively. Additionally, we can see that Clarke farm surface soils were more acidic than Bio-CT, Bio-NT and Control treatments (Table 10) at the time of sampling.

Table 10 – Mean surface (0 to 15 cm) and subsurface (50 to 65 cm) soil pH by treatment for the Carraway-Winn Reclamation Research Farm (Summer 2005) and external comparison areas. Values within columns followed by the same letter are not different ($p \leq 0.05$). Subsurface values in bold face differ from overlying surface values ($p \leq 0.05$).

Treatment	Mean Surface (0 – 15 cm) Soil pH	Mean Subsurface (50 to 65) Soil pH
Bio-CT	7.10a	5.05ab
Bio-NT	7.21a	5.01ab
Control	6.51b	4.82b
Topsoil	5.68c	5.00ab
Clarke Farm	5.82	5.86
Compacted Area	6.74	5.09

The higher pH in the two biosolids treatments reflects the reactive lime additions added with the biosolids while the lower pH of the Topsoil treatment indicates that either the fall applied lime was slow to react and/or the liming rate may have been mis-specified. This also indicates that the topsoil used for this treatment more than likely came from a non-agricultural forest site without a history of liming and fertilization. Because of the large amount of woody debris that was removed from the Topsoil plots after tillage and site preparation. The Clarke farm soils were more similar in surface vs. subsurface pH, unlike the Bio-CT, Bio-NT, and Control treatments which had much lower subsurface pH. It is also interesting to note that the subsurface pH for the Clarke farm was similar to the surface pH for the Topsoil on the CWRF. Individual contrasts indicated that the Clarke Farm was significantly lower in surface soil pH than the two Biosolid treatments ($p < 0.0001$), the Topsoil ($p < 0.0001$) and Control treatments ($p < 0.0001$) respectively.

Compacted Area soils were moderately acidic to mildly alkaline with average surface and subsurface pH values of 6.74 and 5.09, respectively. Individual contrasts indicated that the Compacted Area was significantly higher in surface pH than the Clarke Farm ($p < 0.0001$) and Topsoil ($p < 0.0001$), and lower than the Bio-NT ($p < 0.01$) plots. Surface pH values for the

Compacted Area were significantly lower than the two Biosolid treatments, due to lime stabilized biosolids plus liming practices applied to the surrounding area that were different from the research plot area. Individual contrasts of the Compacted Area vs. all four soil reconstruction techniques were not significantly different for subsurface pH; however the Compacted Area was lower than the Clarke Farm ($p < 0.0001$).

3.3.2 Soil Macronutrients

Acid extractable phosphorus (P) levels (Table 11) generally varied by treatment and depth. The Topsoil treatment had the lowest available P at 14 kg, followed by the Control, with an average available P of 22 kg. There was a wide variance in P levels for each treatment, and relatively low P levels in the Topsoil return treatment despite lime and P-fertilizer additions. There was a strong treatment effect ($p < 0.01$) in surface soil P for the CWRF with the two Biosolids treatments much greater ($p < 0.002$) than both the Control and Topsoil reconstruction treatments. Average surface soil P for the Clarke Farm was 51 mg/kg (Table 11), and the Clarke Farm was also higher in surface soil P than the two Biosolid treatments ($p < 0.03$). Average surface soil P of the Compacted Area was 13 mg/kg with a maximum of 21 mg/kg and a minimum of 5 mg/kg. Low P levels may be result of phosphorous fixation, or the chemical reaction of available phosphorous with iron and aluminum at low pH values (or Calcium at high pH values) that can cause plant available phosphorous to become unavailable. Given that the Topsoil treatment had relatively low surface and subsurface pH values, and that these soils are rich in iron and aluminum, P fixation may have occurred.

Table 11 – Mean surface (0 to 15 cm) and subsurface (50 to 65 cm) acid-extractable P (mg/kg) for auger samples at the Carraway-Winn Reclamation Research Farm (Summer 2005) and external comparison areas. Values within columns followed by the same letter are not different ($p \leq 0.05$). Subsurface values in bold face are different from overlying surface values ($p \leq 0.05$).

Treatment	Mean surface P (0 – 15 cm) (mg/kg)	Standard Deviation	Mean Subsurface P (50 – 65 cm) (mg/kg)	Standard Deviation
Bio-CT	45a	19	5a	4
Bio-NT	45a	15	6a	3
Control	22b	13	3a	1
Topsoil	14b	14	3a	1
Clarke Farm	51	32	3	3
Compacted Area	13	8	3	1

Average subsurface available P for Bio-CT was 5 mg/kg, average subsurface P for Bio-NT was 6 mg/kg, average available subsurface P for the Control was 3 mg/kg, and average available subsurface P for the Topsoil was 3 mg/kg. Although the ANOVA test showed that there was a significant difference between the mean subsurface P-levels ($p < 0.01$), no significant treatment effects or block or block*treatment interactions (all p -values > 0.1) were observed. The higher standard deviations and thus higher variability for both of the Biosolid treatments are most likely a result of the lime-stabilized biosolids which help to alleviate phosphorous fixation.

As expected, Ca levels varied with treatment ($p < 0.001$) and depth (Table 12). Due to large additions in the lime stabilized biosolids, the Bio-CT (2041 mg/kg) and Bio-NT (1655 mg/kg) were much higher than the Control and Topsoil treatments ($p < 0.0001$) at 608 mg/kg, and 599 mg/kg respectively. There was a moderate treatment effect ($p < 0.05$) and a significant block effect ($p < 0.0005$) for average subsurface Ca levels. Bio-NT had the highest Ca (348 mg/kg), followed by Bio-CT (314 mg/kg), presumably due to limited leaching from the incorporated biosolids. However, in contrast with the surface soil effects, the Control treatment had the lowest subsurface Ca (204 mg/kg) compared with the Topsoil, slightly higher (but not

significantly higher) at 266 mg/kg. The Clarke Farm and Compacted Area had average surface and subsurface available Ca of 388, 541, and 432 and 227 mg/kg respectively (Table 12).

Table 12 – Mean surface (0 to 15 cm) and subsurface (50 to 65 cm) calcium (mg/kg) for the Carraway-Winn Reclamation Research Farm and external comparison areas. Values within columns followed by the same letter are not different ($p \leq 0.05$). Subsurface values in bold face are different from overlying surface values ($p \leq 0.05$).

Treatment	Mean Surface Ca (0 – 15 cm) (mg/kg)	Standard Deviation	Mean Subsurface Ca (50 – 65 cm) (mg/kg)	Standard Deviation
Bio-CT	1655a	820	313ab	142
Bio-NT	2041a	1070	348a	115
Control	608b	190	204c	98
Topsoil	599b	164	266bc	173
Clarke Farm	388	75	432	68
Compacted Area	547	138	227	79

Treatment contrasts indicated that surface soil Ca levels at the Clarke Farm were less than all four soil reconstruction techniques ($p < 0.009$), but in the subsurface, Clarke Farm Ca levels were significantly greater than all four CWRP treatments, presumably due to long-term agronomic liming. Individual contrasts of the Compacted Area showed that it was lower in surface soil Ca than the two Biosolids treatments ($p < .001$).

3.3.3 Total Carbon Content

Total carbon content (TC) on surface samples ranged from 0.09 % to 1.09 % across all four treatments. The Topsoil treatment had the highest average TC of 0.75 % followed by Bio-CT, which had an average TC of 0.61 %. The Control had the lowest TC of 0.29 %. There were differences in TC ($p < 0.008$) between all four soil reconstruction techniques. Total carbon content for the Compacted Area ranged from 0.17 % to 0.60 % with a mean of 0.38 % (Table 13). Total carbon content for the Clarke Farm ranged from 0.37 to 0.87 with an average of 0.53

%.

Individual contrasts indicated that the Clarke Farm was lower in TC than the Topsoil treatment ($p < 0.01$), but did not differ from the other three reconstruction treatments. Considering that the Clarke farm has been under an intensive agricultural regime and the Topsoil used for this experiment was from a forested source, lower TC values within the Clarke Farm are expected.

Comparing the standard deviations between the two similarly managed Biosolids treatments, Bio-NT appears to be more variable (stdev = 0.236) than Bio-CT (stdev = 0.185). Although these two treatments were supposedly essentially equivalent, Table 13 suggests otherwise. The Bio-NT treatment was significantly higher in average Total Carbon than the Bio-CT ($p < 0.002$); it appears that the Bio-NT received more biosolids than the Bio-CT treatment or incorporation was not as effective. Although not significantly different, a large numerical difference in mean surface Ca content (see Table 12) was observed between the two Biosolid treatments.

Table 13 – Mean surface (0 to 15 cm) total carbon (mg/kg) for auger samples at the Carraway-Winn Reclamation Research Farm and external comparison areas. Values within columns followed by the same letter are not different ($p \leq 0.05$).

Treatment	Average Total Carbon (%) (0 – 15 cm)	Standard Deviation
Bio-CT	0.45c	0.185
Bio-NT	0.61b	0.236
Control	0.29d	0.091
Topsoil	0.75a	0.140
Clarke Farm	0.53	0.129
Compacted Area	0.38	0.11

3.4 Rooting Observations

As discussed in the preceding sections, the CWRF plots were sampled at 80 locations over the summer of 2005. All auger borings were under corn, and plant roots appeared throughout the bulk of surface soils to an average depth of 44 cm (17 inches) across all four treatments. Root counts were performed to the depth of observable rooting, usually the first 4 or 5 (21-cm deep) auger buckets. Although the two Biosolid treatments were essentially the same, rooting was deepest in the Bio-CT plots, followed closely by the Bio-NT, Control, and Topsoil treatments respectively (Table 14).

Table 14 – Mean depth of detectable rooting by treatment at the Carraway-Winn Reclamation Research Farm (Summer 2005) and external comparison plots. Values within columns followed by the same letter are not different ($p \leq 0.05$).

Treatment	Depth (cm)	Depth (inch)
Bio-CT	57a	22a
Bio-NT	49ab	19ab
Control	39ab	15ab
Topsoil	33ab	13ab
Clarke Farm	71	28
Compacted Area	62	24

The three soil reconstruction treatments did not differ from each other ($p > 0.17$) in rooting depth. The Clarke Farm and the four soil reconstruction treatments were contrasted individually in rooting depth. There was no difference between the Clarke Farm and the Bio-CT treatments, which may have been due to 1) insufficient field observations, 2) that field observations may have not accounted for rooting within desiccation cracks at the CWRF, or that 3) there really was no difference between total observable rooting depth between the two locations. In addition, the Compacted Area and the four soil reconstruction treatments were

contrasted individually and that analysis indicated that rooting in the Compacted Area was deeper than both the Control ($p < 0.01$) and the Topsoil ($p < 0.004$) treatments.

Given the above observations (Table 14), mean root counts at a specific depth (42 cm (16.5 in)) were then contrasted to better determine if there was a significant effect of soil reconstruction technique on deeper root mass/density ($p < 0.07$; Table 15). At a depth of 42 cm, Bio-NT had the largest root mass per auger tip followed closely by Bio-CT and Control treatments. There was a significant increase in the amount of root mass for the Bio-NT treatment vs. Bio-CT, Topsoil and Control treatments. In addition, there was a lack of rooting observed beneath the Topsoil treatment when compared to the Compacted Area and Clarke Farm rooting at depth. Individual contrasts between the Clarke Farm and the CWRF indicated that observed rooting was marginally higher in the Clarke Farm than the Bio-CT, Control and Topsoil treatments ($p < 0.07$). Additionally, individual contrasts between the Clarke Farm and the Compacted Area showed that there was no significant difference between them.

Table 15 – Mean root counts at 42 cm (16.5 in.) by treatment at the Carraway-Winn Reclamation Research Farm (Summer 2005) and external comparison plots. Values within columns followed by the same letter are not different ($p \leq 0.05$).

Treatment	Mean Root Counts at 42 cm (16.5 inches)
Bio-CT	1.4b
Bio-NT	2.5a
Control	1.4b
Topsoil	0.6b
Clarke Farm	2.5
Compacted Area	2.3

3.5 Crop Yields as affected by Soil Reconstruction Treatments

The average corn seedling count and average corn seedling height of the CWRF are shown in Table 16. There was no significant difference between the seedling counts; however, there was a significant difference between average seedling heights with the two Biosolid treatments producing the tallest seedlings and the Topsoil treatment producing the shortest plants.

Table 16 – Average corn seedling count and seedling height by treatment on May 18, 2005. Values followed by the same letter are not different ($p \leq 0.05$).

Plot	Seedling Count ¹ (# of plants)		Seedling Height ² (cm)	
	avg per plot	Treat. means	avg per plot	Treat. Means
Bio-CT				
102	104		18.5	
204	101		16.8	
302	95		20.1	
403	100	100 a	18.5	18.5 a
Bio-NT				
101	106		18.5	
202	99		17.5	
301	100		20.1	
404	104	102 a	19.8	18.8 a
Topsoil				
104	104		12.2	
201	100		11.4	
303	69		11.7	
402	96	92 a	12.7	11.9 b
Control				
103	107		13.7	
203	99		13.0	
304	101		11.9	
401	101	102 a	15.5	13.5 b
Clark Farm (unmined)³				
C	91		14.2	
C1				
C2				
C3				
C4				

¹Seedling counts are based on 4 15-m transects per plot for the Clarke farm.

²Seedling heights are based on 20 observations per plot and 26 observations for the Clark Farm.

³The Clarke Farm was not delineated into plots at the time seedling counts and heights were observed; therefore C encompasses the area subsequently divided into C1, C2, C3 and C4.

3.5.1 Corn Yields (2005)

Mean corn yields for the four treatments are presented in Table 17 along with comparative yield data for the Clarke Farm and Compacted Area. Although corn yields on the two Biosolids treatments were not different from each other, they were significantly higher than both the Control and Topsoil treatments ($p < 0.0001$). Unexpectedly, the Topsoil treatment produced the lowest crop yield at 3,785 kg/ha. Lower yield on the Topsoil treatment was most likely a result of low soil pH (5.68), low available P (14 mg/kg), compaction during topsoil placement, and the formation of a surface crust that occurred after several heavy rains in April and May of 2005. The Bio-NT and Bio-CT treatments produced the highest average crop yields of 10,904 kg/ha and 10,848 kg/ha, respectively. The Control treatment yielded 8,527 kg/ha, which was greater than the Topsoil treatment. Lower yields in the Control plots (compared to the two Biosolid treatments) were most likely due to lower nutrient levels and lower levels of organic matter which may have reduced soil water holding capacity. Lower yields in the Control and Topsoil treatments may have also been reduced by the higher subsoil strength relative to the biosolids treatments as reported earlier (Table 9).

In 2005, the Clarke Farm and the Compacted Area produced 14,360 kg/ha and 6,070 kg/ha respectively, which were clearly much higher and lower, respectively, than the average Biosolids and Control treatment yields. The Clarke Farm average was an estimated yield of 3 GPS strips and therefore no direct statistical contrasts were performed. County average yields for corn over a five-year period (Table 17) ranged from 2,571 to 7,776 kg/ha, the lowest yield occurring in 2002 (a drought year) and the highest occurring in 2004. Over the five-year period, average county corn yields were 5,543 kg/ha. As mentioned earlier, however, it is important to

point out that our corn plots were irrigated frequently in 2005 while the county yield data base includes non-irrigated and irrigated fields.

Table 17 – Corn yield by treatment for 2005 and average yields between 2001 and 2005 for Dinwiddie County, Virginia. Values followed by the same letter are not different ($p \leq 0.05$).

Treatment	Mean Crop Yield (kg/ha)	Mean Crop Yield bu/a*	Dinwiddie County Average (kg/ha)					
			Five Year Average	2001	2002	2003	2004	2005
Bio-CT	10,848a	172a	5,543	5,393	2,571	5,267	7,776	6,709
Bio-NT	10,904a	173a						
Control	8,527b	135b						
Topsoil	3,785c	60c						
Clarke Farm	14,360**	229**						
Compacted Area	6,070	96						

*bu/a at 15 % moisture

**Due to mechanical failure, Clarke Farm yields were based on an overall estimate from the yield monitor output rather than four replicate plots.

The two Biosolids treatments (CT and NT) and the Control produced higher average yields (+ 97%, + 97% and + 54%, respectively) than the five-year-county-average, while the Topsoil treatment produced significantly less (- 32%) than the five-year-county-average. It is interesting to note that the Clarke Farm, although under identical management conditions as the CWRF, produced much higher comparative yields than all experimental soil reconstruction treatments. However, as noted earlier, it is important to point out that the research plots (including the Clarke Farm) were irrigated while much of the corn reported in the surrounding county was not.

Figure 24 is a graphical representation of the CWRF corn yields (2005) taken along the center transect of each plot. From this figure, we can clearly see that lower yields occurred more often in the Topsoil treatments than the two Biosolid treatments. Additionally, we can see a lack of crop productivity for the Topsoil treatment in block three (highlighted in red) compared to the

other three soil reconstruction treatments and the other three Topsoil treatments (blocks 1, 2 and 4 respectively).

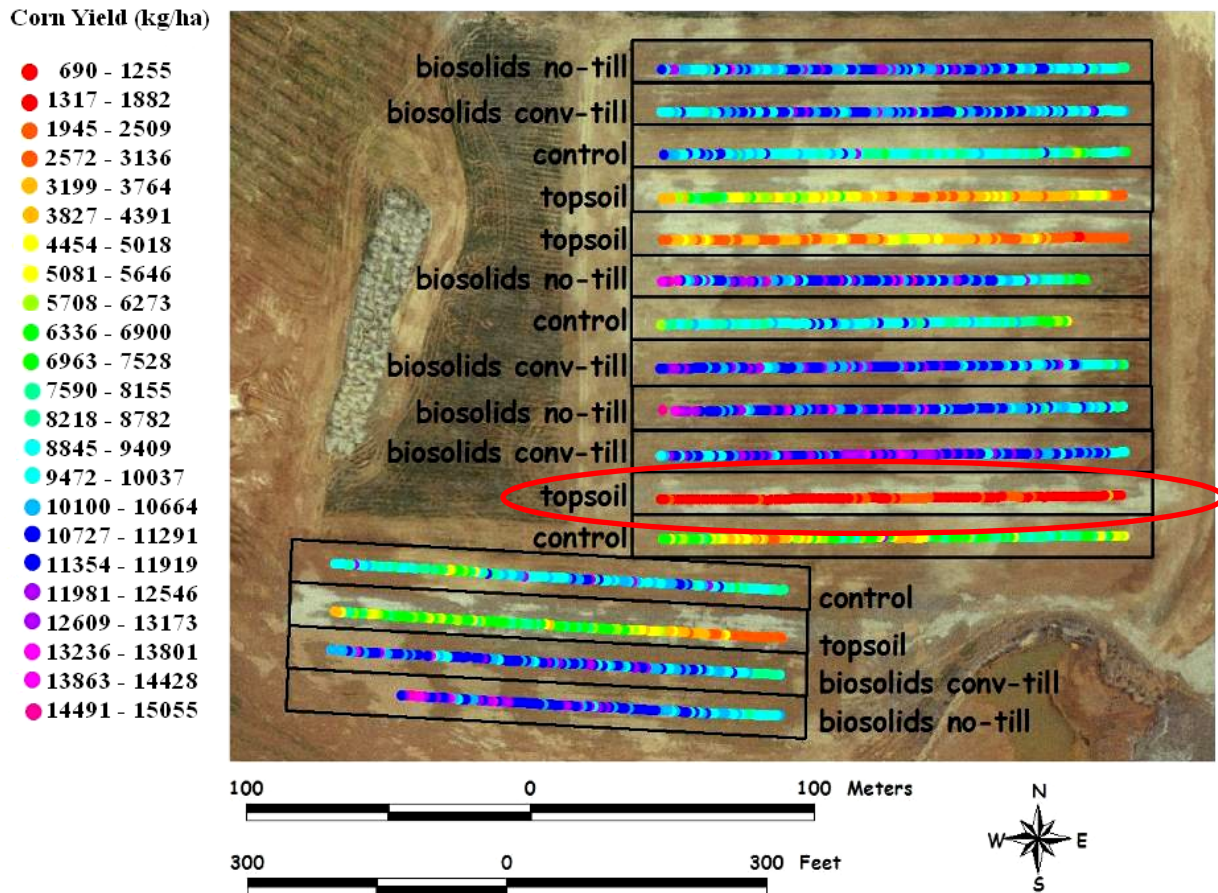

Figure 24 – Corn yields along the center transect of each plot located on the Carraway-Winn Research Farm (CWRF) of the Old Hickory site. Photo courtesy of Pat Donovan.

3.5.2 Wheat Yields (2006)

Bio-NT produced the highest amount of winter wheat in 2006, followed closely by Bio-CT with average yields of 5,326 kg/ha and 4,556 kg/ha respectively. The Control and Topsoil treatments were significantly lower at 4,088 kg/ha and 4,291 kg/ha respectively. Note that the heavy yield suppression in the Topsoil treatment noted for corn in 2005 was not evident in the

following wheat crop. Additionally, the Clarke Farm and the Compacted Area produced 6,900 kg/ha and 4,327 kg/ha respectively. Typical county-wide wheat yields on unmined farmland over a five-year period (Table 18) ranged from 2,889 to 4,165 kg/ha, with lowest yields in 2003. Over the five-year period, Dinwiddie produced an average 3,588 kg/ha of wheat. Again a significant difference is seen between the two Biosolid treatments; similar to the higher carbon content reported earlier. Individual contrasts indicated that the Compacted Area yields were significantly lower than ($p < 0.0001$) the Clarke Farm; however they were not significantly different than the four CWRf soil reconstruction treatments.

Table 18 – Wheat yield by treatment and five-year county averages for Dinwiddie, Virginia. Values followed by the same letter are not different ($p \leq 0.05$).

Treatment	Mean Crop Yield (kg/ha)	Mean Crop Yield bu/a*	Dinwiddie County Average (kg/ha)					
			Five Year Average	2001	2002	2003	2004	2005
Bio-CT	4,556b	67b	3,588	3,695	3,628	2,889	3,561	4,165
Bio-NT	5,326a	79a						
Control	4,088c	60c						
Topsoil	4,291c	62c						
Clarke Farm	6,900	102						
Compacted Area	4,327	64						

*bu/a at 15 % moisture

All four CWRf treatments produced higher average wheat yields (+ 48% -Bio-NT; + 27% -Bio-CT; + 20% - Topsoil; and + 14% - Control) than the five-year-county-average. The Clarke Farm produced much higher comparative yields ($p < 0.0001$) than all experimental soil reconstruction treatments.

3.6 Detailed Soil Morphology and Taxonomy -- Pit Study in 2006

3.6.1 Soil Pit Summary

The soil profiles observed in 2006 were relatively simple in overall morphology, but highly variable in the number of subhorizons observed subsoil physical properties. The majority of pedons (7) described as ^Ap-^C1 followed closely by ^Ap1-^Ap2 (5) and ^Ap-^Bw (5) horization. Important subsurface features observed included densic layers and one buried A (^Ab) horizon. Few pedogenic subsoil horizons were observed, but nine did exhibit weakly expressed ^Bw horization. Of these nine horizons, five were categorized as cambic, approximately 15 cm (or more thick) with a texture of (loamy) very fine sand or finer and moderately well developed soil structure. (Soil Survey Staff, 2006). According to Soil Taxonomy (Soil Survey Staff, 2006); 11 pedons classified as Typic Udorthents, four classified as Typic Udifluvents, and five as Typic Dystrudepts (Table 19).

Table 19 – Taxonomic classifications for Carraway-Winn Reclamation Research Farm and Compacted Area soil pedons.

Pit ID	Treatment	Classification
101-4	Bio-NT	Clayey over sandy, aniso, mixed, acid, thermic, Typic Udorthent
102-3	Bio-CT	Clayey over sandy, aniso, mixed, acid, thermic, Typic Dystrudept
103-2	Control	Coarse-loamy, mixed, nonacid, thermic, Typic Udifluent
104-5	Topsoil	Clayey over sandy, mixed, acid, thermic, Typic Dystrudept
201-2	Topsoil	Loamy, mixed, nonacid, thermic, shallow, Typic Udorthent
202-1	Bio-NT	Coarse-loamy, mixed, nonacid, thermic, Typic Udorthent
203-3	Control	Loamy, mixed, nonacid, thermic, shallow, Typic, Udorthent
204-3	Bio-CT	Coarse-loamy, mixed, nonacid, thermic, Typic Udifluent
301-3	Bio-NT	Fine-loamy, mixed, acid, thermic, Typic Dystrudept
302-3	Bio-CT	Coarse-loamy, mixed, acid, thermic, Typic, Dystrudept
303-2	Topsoil	Coarse-loamy over sandy, mixed, acid, thermic, Typic Dystrudept
304-1	Control	Fine-loamy, mixed, nonacid, thermic, Typic Udorthent
401-5	Control	Sandy over clayey, mixed, nonacid, thermic, Typic Udifluent
402-3	Topsoil	Sandy, siliceous, nonacid, thermic, uncoated, Typic Udorthent
403-5	Bio-CT	Fine-loamy, mixed, acid, thermic, Typic Udorthent
404-1	Bio-NT	Sandy, siliceous, acid, thermic, uncoated, Typic Udorthent
EC 5-2	Compacted	Coarse-loamy, nonacid, mixed, thermic, shallow Typic Udorthent
EC 7-2	Compacted	Fine-loamy over sandy, mixed, acid, thermic, shallow, Typic Udorthent
EC 11-2	Compacted	Coarse-loamy, mixed, acid, thermic, shallow, Typic Udorthent
EC 12-2	Compacted	Sandy over clayey, aniso, mixed, acid, thermic, Typic Udifluent
All pedons assumed to have a udic moisture regime; no active redoximorphic features were noted.		

3.6.2 Soil Color and Overall Morphology

Overall, surface soil (Ap) color ranged from olive brown (2.5Y 4/3) to strong brown (7.5YR 5/6) to yellowish brown (10YR 5/8) with two pedons having a redder soil surface (yellowish red; 5YR 5/8 to 5YR 4/6). The depth of the Ap varied slightly with treatment, with the Bio-CT (10 cm), and Control (10 cm) slightly thicker than Topsoil (9 cm), and slightly thicker than Bio-NT (8.5 cm). It is interesting to note that the Control and Topsoil treatments

had a deeper Ap layer than the Bio-NT treatment, a treatment which was higher in TC (Table 13).

Surface soil textures were consistently sandy clay loams to sandy loams although one sandy loam/loamy sand surface texture was observed (CWRF 403-5; Tables G-1 & G-2 in Appendix G). Surface ^Ap horizons were weak to moderate, granular and subangular blocky in structure, and very friable to friable. One pedon exhibited weak, platy structure (EC 12-2) and one pedon exhibited a friable granular and angular blocky structure in the ^Ap horizon (CWRF 301-3).

Multiple ^Ap horizons (e.g. ^Ap1 over ^Ap2) were described in five of the 20 pedons, CWRF 102-3, 104-5, 201-2, 202-1, and 303-2. ^Ap over ^Bw horizons were described in five of the 20 pedons, CWRF 203-3, 204-3, 301-3 and 302-3, 404-1. Simple ^Ap over ^C horizon morphology was noted in three of the 20 pedons, CWRF 101-4, 401-5, EC 12-2, which were Bio-NT, Control, Compacted Area and Compacted Area respectively. While the overall mine soil morphology observed was highly variable from pit to pit, certain features as described in more detail below recurred commonly. Figs. 25 through 30 reflect representative soils as described in 2006. Full descriptions of all pedons are given in Appendix H and important example descriptions are presented in Table 20.



Figure 25. Profile 404-1 (Bio-NT) is a Typic Udorthent as indicated by the lack of pedogenic horization or other distinctive soil morphological features (Table 20). This profile does show layering of varying textured materials as was typical of these mine soils and moderate compaction in the upper 50 cm. Overall described morphology was $\text{^Ap-^Bw-^C1-^C2-^C3-^C4}$.



Figure 26. Profile 302-3 (Bio-CT) is a Typic Dystrudept as indicated by weak development of a (Bw) pedogenically-altered horizon (Table 20). This soil classified as an Inceptisol due to the presence of a cambic horizon with > 50% moderate subangular blocky structure between 12 and 44cm. This profile also showed typical sequence of finer textured high slimes material over sandy tailings at depth. Described horizons were ^Ap-^Bw1-^Bw2-^C1-^C2.

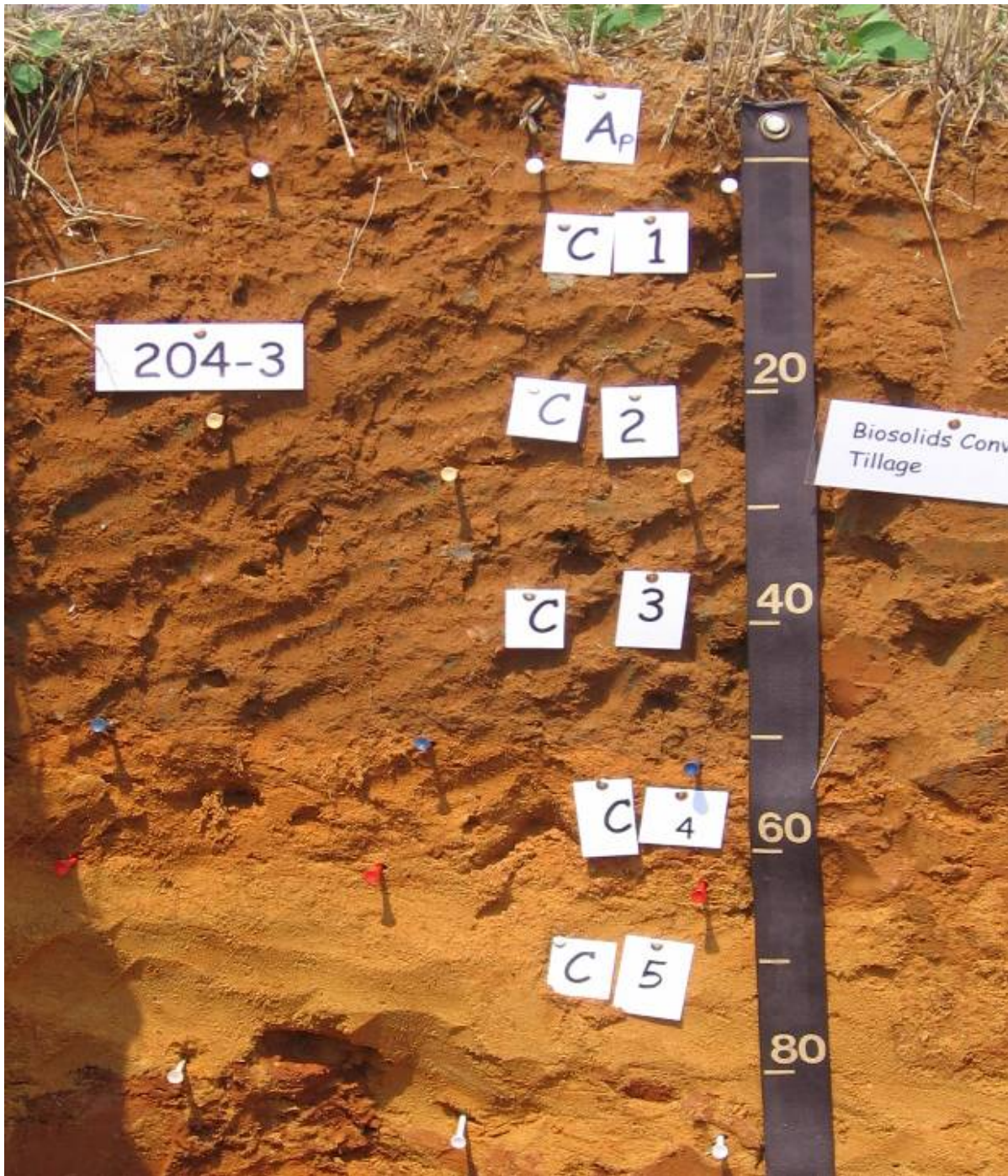

Figure 27. Profile 204-3 (Bio-CT) is a Typic Udifluent as indicated by a lack of pedogenic horizonation and an irregular decrease in Total C (+ 0.2 %) within the particle control section (25 to 100 cm) of the profile (Table 20). The inclusion of A horizon material in the \wedge Bw1 and \wedge Bw2 horizons were responsible for the irregular C content with depth. This was not classified as an Inceptisol because the Bw horizon did not meet the color requirements nor was its structure strong enough to be considered cambic. Please note that horizon names assigned in the field have been altered after careful consideration of all physical and chemical data, and the final morphology was \wedge Ap- \wedge Bw1- \wedge Bw2- \wedge C1-2 \wedge C2-2 \wedge C3-2 \wedge C4.



Figure 28. Profile 203-3 (Control) was a Typic Udorthent with a prominent densic layer (Cd) at 30 to 59 cm (Table 20). Please note the significant topsoil material prominent within the Cd layer. However, the inclusion of topsoil here was not sufficient to be dominant, so this was not described as Ab. Buried topsoil and topsoil-like material were noted in 12 of the 20 profiles. Also note large angular blocks of red slimes material in deeper $2\text{C}2/\text{C}1$ horizon between 80 and 110 cm. These were most likely dried out into blocks over the underlying coarse tailings on an exposed tailings “beach” and then more sandy tailings were deposited over them. Overall described horizon sequence was $\text{Ap}-\text{Bw}-\text{Cd}-2\text{C}1-2\text{C}2/\text{C}1-2\text{C}3$.



Figure 29. Profile EC 11-2 is a typical plot of the Compacted Area (Table 20). Please note that three of the compacted plots were classified as Typic Udorthents except for pit EC 12-2 which was a Typic Udifluent. Note the complex layering and convoluted banding in the sandy tailings between 40 and 70 cm; this was most likely caused by surface re-grading of recently deposited tailings. Overall morphology was described as $\text{^Ap-^Cd-^C1-^C2-^C3}$.



Figure 30. Profile 201-2 in a Topsoil plot (Table 20). This soil was typical of Typic Udorthents described in this study and also contained a significant amount of buried A horizon material. You will also note that the upper 50 cm is significantly compacted and the finer textured upper profile overlies sandy tailings at depth. Overall morphology was described as $\text{^Ap1-^Ap2-^Abd1-^Abd2-2^C1-2^C2}$.

Table 20 - Profile Descriptions of six representative mineral sands mine soils pictured earlier.

Horizon	Depth (cm)	Description
<u>Profile 404-1 (Bio-NT): Typic Udorthent without A_b</u>		
^Ap--	0 – 11	Strong brown (7.5YR 5/8) sandy clay loam; moderate fine granular structure; very friable; moderately few fine to very fine roots; alkaline (pH 7.6); clear smooth boundary.
^Bw--	11 – 22	Strong brown (7.5YR 5/6) sandy loam to sandy clay loam; weak to moderate medium subangular blocky structure; very firm to firm; very few common to many fine to very fine roots; acidic (pH 5.9) clear smooth boundary.
^C1--	22 – 32	Yellowish brown (10YR 5/8) sand with common, coarse, distinct, strong brown (7.5YR 5/8) bodies; moderate medium platy structure; firm to very firm consistence; moderately few fine to very fine roots; strongly acidic (pH 5.3); wavy smooth boundary.
^C2--	32 – 59	Yellowish brown (10YR 5/8) fine sand with common, coarse, distinct, strong brown (7.5YR 5/8), common, coarse, distinct, brownish yellow (10YR 6/8), common, coarse, distinct, strong brown (7.5YR 5/8), and common, coarse, distinct, olive yellow (2.5Y 6/6) bodies; structureless, massive; very friable; moderately few fine to very fine roots; 1 % gravels; strongly acidic (pH 5.2) clear abrupt boundary.
^C3--	59 – 95	Brownish yellow (10YR 6/8) coarse sand with common, coarse, distinct, strong brown (7.5YR 5/8), common, coarse, distinct, brown (10YR 4/3) bands and common, very coarse, distinct, very pale brown (10YR 7/4) banding; structureless, massive; very friable; approximately less than 7 % gravels; strongly acidic (pH 5.1); clear smooth boundary.
^C4 --	95 – 200+	Brownish yellow (10YR 6/8) sandy loam; structureless, massive; firm to friable in places; less than 5 % gravels; strongly acidic (pH 4.9).

Table 20 – Continued,

Horizon	Depth (cm)	Description
<u>Profile 302-3 (Bio-CT): Typic Dystrudept</u>		
^Ap--	0 – 12	Strong brown (7.5YR 5/6) sandy clay loam with common, coarse, distinct, brownish yellow (10YR 6/6) mottles; weak fine subangular blocky structure; friable; moderately few very fine roots; slightly alkaline (pH 7.2); clear smooth boundary.
^Bw1--	12 – 44	Strong brown (7.5YR 5/6) sandy clay loam with few, very coarse, faint, strong brown (7.5YR 5/6) and few, coarse, distinct, gray (7.5YR 6/1), clay slime fragments and common, coarse, distinct, strong brown (7.5YR 5/8) sandy bodies; weak to moderate fine subangular blocky to massive structure; friable; moderately few very fine rooting; acidic (pH 6.0); clear smooth boundary.
^Bw2--	44 – 73	Strong brown (7.5YR 5/6) sandy loam with common, coarse, faint, strong brown (7.5YR 5/6), few, very coarse, distinct brown (7.5YR 5/2), few, coarse, distinct, yellowish red (5YR 5/6), and common, coarse, distinct, brownish yellow (10YR 6/6), bodies; weak fine to medium subangular blocky to massive structure; friable to firm; moderately few very fine and fine roots; strongly acidic (pH 5.0); abrupt smooth boundary.
^C1--	73 – 104	Olive yellow (2.5Y 6/6) sand with common, distinct pale yellow (2.5Y 7/4) sand banding, common, distinct, very dark gray (2.5Y 3/1) sandy clay, common, very coarse, prominent, strong brown (7.5YR 5/6), red clay, and common, prominent, reddish yellow (7.5YR 6/8) sand banding; structureless, massive; very friable; less than 3 % gravels; strongly acidic (pH 5.1); clear smooth boundary.
^C2--	104 – 120+	Strong brown (7.5YR 5/6) sand with many, prominent, pale yellow (2.5Y 7/4), and many, prominent, brownish yellow (10YR 6/8) bands; structureless, massive; very friable; strongly acidic (pH 5.5).

Table 20 – Continued,

Horizon	Depth (cm)	Description
<u>Profile 204-3 (Bio-CT): Typic Udifluent</u>		
^Ap--	0 – 9	Strong brown (7.5YR 5/6) sandy loam with few, coarse, distinct, dark grayish brown (10YR 4/2), bodies; moderate fine to medium granular structure; friable; moderately few very fine roots; strongly acidic (pH 8.0); clear smooth boundary.
^Bw1--	9 – 34	Strong brown (7.5YR 5/6) sandy loam with common, very coarse, distinct, gray (7.5YR 6/1) common very coarse, distinct, gray (7.5YR 5/1), common, coarse, prominent, olive yellow (2.5Y 6/6), fragments of an A horizon and few, coarse, distinct, yellowish red (5YR 5/6), bodies; weak fine subangular to angular blocky structure; friable; moderately few very fine roots; neutral (pH 6.9); clear wavy boundary.
^Bw2--	34 – 58	Strong brown (7.5YR 5/6) sandy loam with common, very coarse, prominent, light brownish gray (10YR 6/2), common, very coarse, prominent, grayish brown (10YR 5/2), fragments of an A horizon, and common very coarse, distinct, yellowish red (5YR 5/6), and few, coarse, prominent, olive yellow (2.5Y 6/6) bodies; weak medium angular blocky structure; friable; moderately few fine roots; strongly acidic (pH 4.9); abrupt smooth boundary.
^C1--	58 – 69	Reddish yellow (7.5YR 6/8) sandy loam with common, extremely coarse, distinct, strong brown (7.5YR 5/6), and common, medium, distinct, brownish yellow (10YR 6/8) streaks and bodies; friable; structureless, massive; moderately few fine roots; 1 % gravels; strongly acidic (pH 4.8); abrupt smooth boundary.
2^C2--	69 – 92	Brownish yellow (10YR 6/8) sand with common, coarse, distinct, strong brown (7.5YR 5/6) banding, and common, coarse, distinct, reddish yellow (7.5YR 6/8) clay slime bodies; structureless, massive; very friable; 1 to 2 % gravels; strongly acidic (pH 5.4); abrupt wavy boundary.
2^C3--	92 – 104	Yellowish red (5YR 5/8) clay with common, coarse, distinct, reddish yellow (7.5YR 6/8), bodies; structureless, massive; firm; strongly acidic (pH 4.7); abrupt smooth boundary.
2^C4--	104 – 130+	Reddish yellow (7.5YR 6/8) sand with common, coarse, faint, reddish yellow (7.5YR 7/8) bands; structureless, massive; very friable; less than 5 % gravels; strongly acidic (pH 5.5).

Table 20 – Continued,

Horizon	Depth (cm)	Description
<u>Profile 203-3 (Control): Typic Udorthent w/densic layer</u>		
^Ap--	0 – 7	Yellowish red (5YR 5/8) sandy clay loam with many, medium, faint, yellowish red (5YR 4/6), common, fine, distinct, reddish yellow (7.5YR 7/6), and many, medium, prominent, light gray (7.5YR 7/1), bodies; moderate medium granular structure; friable; moderately few very fine roots; alkaline (pH 7.5); clear smooth boundary.
^Bw--	7 – 30	Yellowish red (5YR 5/8) sandy loam with few, fine, distinct, light gray (7.5YR 7/1) fragments of an A horizon; weak fine to medium subangular blocky structure; friable; moderately few very fine to fine roots; acidic (pH 5.8); gradual wavy boundary.
^Cd--	30 – 59	Strong brown (7.5YR 5/8) sandy loam with many, medium, prominent, dark grayish brown (10YR 4/2) and few, fine, distinct, light gray (7.5YR 7/1) fragments of an A horizon; weak medium subangular blocky structure; sandy material friable, clay slimes firm; very few very fine roots, 1 % cobbles; acidic (pH 5.0); clear smooth boundary.
2^C1--	59 – 81	Reddish yellow (7.5YR 6/8) sand with reddish yellow (7.5YR 7/8) and yellow (10YR 7/8) banding; structureless, massive; very friable; 1 % gravels; strongly acidic (pH 5.1); gradual wavy boundary.
2^C2/C1--	81 – 102	Reddish yellow (7.5YR 6/8) sandy clay loam with many very coarse, distinct, yellowish red (5YR 5/8) clay slime bodies; strong brown (7.5YR 5/8) streaks, or thin strata along clay ped faces, structureless, massive; very friable in sand with extremely firm clay; 1 % gravelly coarse fragments; strongly acidic (pH 4.8); clear wavy boundary.
2^C3--	102 – 130+	Yellowish brown (10YR 5/8) sand with many, distinct, very pale brown (10YR 8/4), bodies; structureless, massive; very friable; acidic (pH 5.8).

Table 20 – Continued,

Horizon	Depth (cm)	Description
<u>Profile EC 11-2 (Compacted Area): Typic Udorthent</u>		
^Ap--	0 – 13	Strong brown (7.5YR 5/6) sandy loam; weak fine granular to moderate medium subangular blocky structure; very friable; moderately few fine to very fine roots; slightly acidic (pH 6.7) gradual smooth boundary.
^Cd--	13 – 41	Strong brown (7.5YR 5/8) sandy clay loam with an increase in clay towards bottom of horizon with common, medium to coarse, distinct, yellowish red (5YR 5/6) clay bodies; structureless, massive; firm; very few fine to very fine roots; strongly acidic (pH 4.9); abrupt smooth boundary.
^C1--	41 – 67	Yellowish brown (10YR 5/8) sandy loam with common, coarse, faint, brownish yellow (10YR 6/8) bodies, and common, fine, faint, yellowish brown (10YR 5/8), common, fine, faint, brownish yellow (10YR 6/6) and common, fine, prominent, yellowish red (5YR 5/8) clay slime bodies, and common, fine, distinct, very dark grayish brown (10YR 3/2) heavy mineral sand strata; structureless, massive; clay is firm, sand is friable; very few fine to very fine roots at top of horizon only; strongly acidic (pH 4.8); abrupt wavy boundary.
^C2--	67 – 92	Yellowish brown (10YR 5/8) sand with many, fine to medium, faint, brownish yellow (10YR 6/8) clay slime bodies, and many, fine, distinct, brown (10YR 4/3) heavy mineral sand strata; structureless, massive; friable; strongly acidic (pH 4.9); abrupt smooth boundary.
^C3--	92 – 200+	Yellowish brown (10YR 5/8) sandy loam to loamy sand with common, coarse, distinct, dark brown (10YR 3/3) heavy mineral sand strata and common, coarse, distinct, brownish yellow (10YR 6/6) sand bodies; structureless, massive; firm; acidic (pH 5.1).

Table 20 – Continued,

Horizon	Depth (cm)	Description
<u>Profile 201-2 (Topsoil): Typic Udorthent w/Ab</u>		
^Ap1--	0 – 10	Yellowish brown (10YR 5/6) sandy loam with common, medium, prominent, reddish yellow (5YR 5/6), clay slime fragments, and many, medium, distinct, olive brown (2.5Y 4/4), bodies mottles; sandy loam; weak coarse granular structure; very friable; moderately few very fine roots; slightly alkaline (pH 7.3); clear smooth boundary.
^Ap2--	10 – 19	Strong brown (7.5YR 5/6) sandy loam with, common, coarse, distinct, yellowish brown (10YR 5/6) bodies, weak fine to medium subangular blocky structure; firm; very few very fine to fine roots; alkaline (pH 7.5); clear smooth boundary.
^Abd1--	19 – 30	Strong brown (7.5YR 5/6), sandy loam with common, medium, yellowish red (5YR 5/6), and common, medium, distinct, grayish brown (10YR 5/2) topsoil bodies; structureless, massive; firm; near neutral (pH 6.5); clear wavy boundary.
^Abd2--	30 – 59	Yellowish brown (10YR 5/6) sandy loam with common, medium, olive brown (2.5Y 4/3) bodies with few, coarse, distinct, strong brown (7.5YR 5/8), clay aggregates; structureless, massive; very firm; strongly acidic (pH 5.4); abrupt wavy boundary.
2^C1--	59 – 90	Variegated brownish yellow (10YR 6/8), yellow (10YR 7/6), and yellowish red (5YR 5/8) sand; structureless, massive; very friable; acidic (pH 6.3); abrupt smooth boundary.
2^C2--	90 – 130+	Strong brown (7.5YR 5/8) sand with alternating yellowish brown (10YR 5/8) and yellowish red (5YR 5/8) strata; structureless, massive; strongly acidic (pH 5.1); very friable.

Rounded macro structure (see Fig. 31) in high slimes/clay subsoils was noted in two of the 20 pedons; CWRF 102-3 and 103-2, which were Bio-CT and Control treatments respectively. In active operations, after the ore is mined and sent to the wet mill, slimes and tailings are separated via gravity separation and pumped back into the mine pits (Section III Materials and Methods). This ‘rounded morphology’ is most likely a result of how slimes settle and dry within the soil profile after backfilling of the mining pits. A high slimes layer is laid over a fresh layer of sandy tailings. Sandy material drains water from below from the slimes, thus causing the clay to desiccate and form large polygons and cracks (Figs. 28 and 31). Slime material is then covered with a fresh layer of sandy tailings. Notice how sand appears in desiccation cracks between two blocks of slimes in those two figures. In addition to rounded morphology, small perforations, or holes, were noted in the blocky slimes pedes of both CWRF 102-3 and 103-2 (Appendix H: Detailed Soil Pits). These perforations tended to occur more commonly in pedes with this rounded morphology.



Figure 31. A closer view of Profile 103-2 (Control) showing rounded faces on dewatered chunks of slimes. This overall morphology is most likely the result of dessication of a high slimes layer in the drying surface of a mine pit that was then covered with a fresh layer of sandy tailings.

Convuluted banding (Orndorff et al. 2005) are bands, or thin layers, of heavy mineral sands, clay slimes and sandy tailings that are overturned within the soil profile causing a visibly ‘mixed’ and ‘overturned’ effect (Fig. 32). Orndorff et al. (2005) concluded that banding of this nature, which doesn’t occur in natural soils without vertic mixing or periglacial solifluction, may be a direct result of soil upheaval caused by bull dozers and ‘shaking of slimes’ during reclamation procedures. Additionally, they also suggested that banding of this nature may be a diagnostic feature of these specific mine soils. Convuluted banding was noticed in three of the 20 pedons, CWRP 102-3, 403-5 and EC 12-2, Bio-CT, Bio-CT and Compacted Area respectively in dominantly bulldozer tracked and sandy layers.

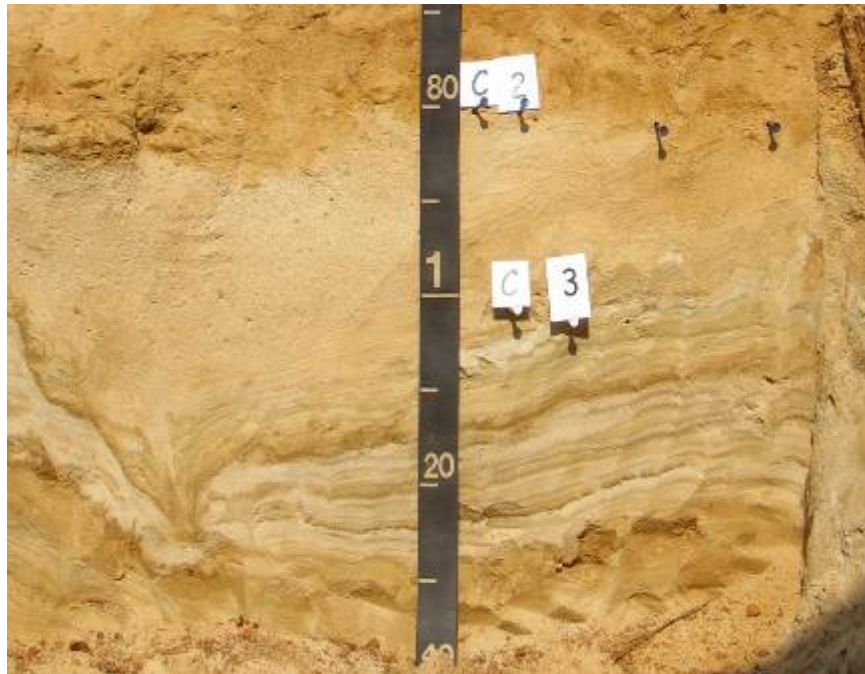

Figure 32. Several subsoil horizons within pits were characterized by thin bands of heavy minerals and tailings that were overturned and deformed as referred to by Orndorff et al. (2005) as convoluted banding.

Although all soils observed in 2006 were deep-ripped in fall 2004 in two perpendicular directions (with and 90° to plot axis), visual traces were only evident in two profiles, CWRF 102-3 (Bio-CT) and CWRF 104-5 (Control). Ripper traces were described based on the overall v-shape of the trace and the depth (~ 90 cm) at which traces were evident (Fig. 33). It is interesting to note that of all 16 CWRF pedons; only two exhibited any visually obvious indication of deep-ripping. Ripper traces may not have been evident due to either 1) the majority of the soils may have been ripped while wet, which would have allowed the ripper traces to close immediately behind the shank and would have limited lateral soil shattering, or 2) alternatively, repeated vehicle passes and natural settling processes may have combined to re-consolidate the original ripper traces.



Figure 33. Southern wall of CWRF 101-4 (Ripping traces highlighted in red). Please note the v-shaped ripper trace (out-lined in red) in the upper half of the pit face. Ripping traces were only noted within CWRF 102-3 and 104-5.

Striations of dark heavy mineral sands coupled with lighter-colored sandy tailings and dark red clay slimes were noted within four of the 20 pedons, CWRF 101-4, 104-5, and 202-1, and EC 5-2, which were Bio-NT, Topsoil and Bio-NT and Compacted Area treatments respectively. Unlike convoluted banding, this material appeared virtually horizontal and undeformed (Fig. 34). These features were classified as deposition of tailings material with similar characteristics to lamella because of their overall appearance; however, they did not have the necessary silicate clay to be classified as actual lamellae. It is also questionable whether they formed via illuviation or are simply artifacts of the tailings deposition process. According to Soil Survey Staff (2006), lamellae are illuvial layers less than 7.5 cm thick formed in unconsolidated

regolith and must have an overlying eluvial horizon. They typically form in well to excessively drained soils in the Atlantic Coastal Plain region.



Figure 34. Alternating layers of tailings (lighter sandy material) and slimes (red clayey material), with thin bands of black HMS. These features were described as deposition of tailings material with similar characteristics to lamellae.

In one pedon, CWRP 103-2 (Control), we described a wood ash and charcoal layer, with a black color (2.5Y/N) (Fig. 35). This layer, which varied in depth between 52 and 60 cm, was non root-limiting, structureless and rich in charcoal and woody debris. It was most likely a result of a slash fire of woody debris that was raked and picked from the forest topsoil materials that were transported from off-site.

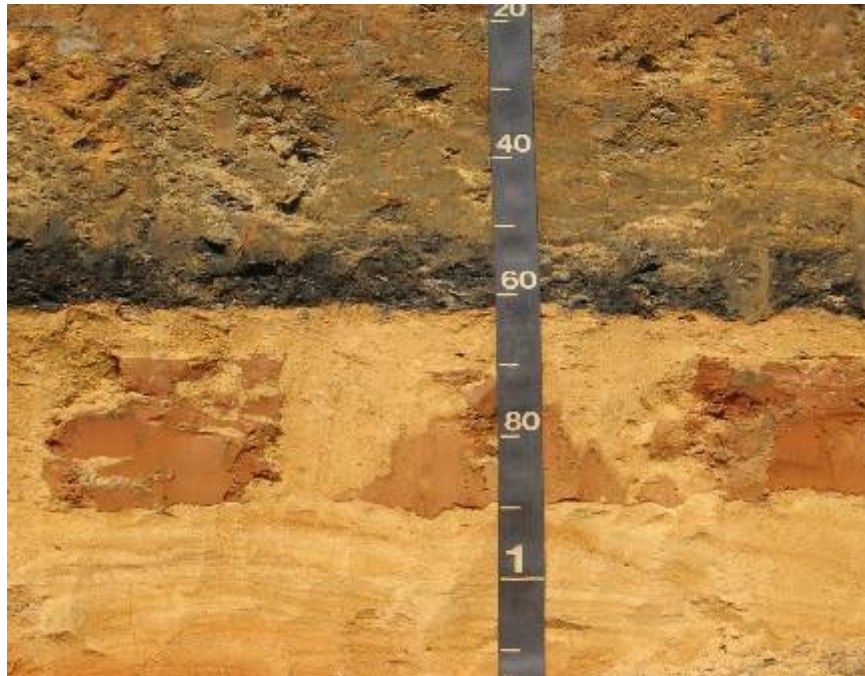

Figure 35. Wood ash and charcoal in CWRF 103-2 (Control) at 52 to 60 cm. This layer varied in thickness from 46 to 60 cm (up to 14 cm) within the soil profile. The C horizon here also contains the large angular chunks of dewatered/cracked slimes over/under tailings as described earlier.

3.6.3 Important Subsoil Properties

Overall, subsurface soil colors varied from black (2.5Y/N) to light olive brown (2.5Y 5/6) to light yellowish brown (2.5Y 6/4), with the majority of colors being strong brown (7.5YR 5/6 to 5/8). Control plots had the most variable subsoil colors with one instance due the thin layer of woody ash/charcoal material described above. Distinct, prominent and faint mottling was evident in a majority of the pedons, with the majority of mottles appearing as distinct, or falling on the same page or one page difference between mottle and matrix colors. These color variegations were not redox-related, however, and are therefore referred to as fragments or mottles.

In addition to the ash layer (CWRP 103-2) previously mentioned, CWRP 201-2 had < 1 % ashy material in the ^A horizons and flakes/inclusions of ash material were noted in the ^Ad and ^C1 horizons. Artifacts (man-made objects) were found in CWRP 202-1, CWRP 303-2 and CWRP 402-3. And those horizons designations therefore carry the “u” subscript. CWRP 202-1 had a plastic sheeting that occurred between the ^Apu and ^Bwu horizon that most likely influenced the wavy boundary. CWRP 303-2 contained pieces of a plastic liner within the ^Apu layer, and CWRP 402-3 contained a small rubber hose (< 2 cm in diameter) located within the upper portion of the 2^Cu horizon.

Subsoil textures ranged widely from clay loam, sandy clay loam, loamy sand, sandy loam, to sand, and some horizons contained laterally distinct mixtures of clay to silty clay, and clay loam to sandy clay. Overall, subsoil structure appeared structureless massive with some weak platy structure appearing in the Topsoil and Bio-NT treatments. Moderate medium subangular blocky structure occurred within cambic horizons described in CWRP 204-3 (Bio-CT) and CWRP 301-3 (Bio-NT) profiles respectively. Overall, subsoil consistence (moist) was very friable to friable (for most treatments) with very friable to firm occurring more frequently for the Topsoil treatments. However, extremely firm subsoil consistence was noted in at least one of the subsoils for each soil treatment. Subsoils in the Control and the Topsoil treatments had firmer overall consistence than pedons located in the two Biosolid treatments.

Few profiles exhibited any diagnostic subsurface horizonation. A densic layer, or non cemented root limiting/restricting layer (e.g. a traffic/tillage pan), was described in five of the 20 profiles, CWRP 201-2, CWRP 203-3, EC 5-2, EC 7-2 and EC 11-2, which were Topsoil, Control, and Compacted Area (×3) treatments respectively. Of these five profiles, CWRP 201-2 had densic layer(s) between 19 to 59 cm, CWRP 203-3 had a densic layer between 30 and 59 cm,

EC 5-2 had a densic layer between 14 and 27 cm, EC 7-2 had a densic layer between 6 and 24 cm and EC 11-2 had a densic layer between 13 and 41 cm. However, densic properties and associated rooting limitations were observed in almost all described soil profiles, but rigorously defined densic layers (Soil Survey Staff, 2006) were not apparent.

Various profiles showed evidence of topsoil-like material throughout the subsurface; however, only one buried A horizon was described that appeared to be completely comprised of former topsoil. This occurred in pedon CWRF 201-2, which was a Topsoil treatment. Conversely, many other profiles showed evidence of buried and mixed topsoil material. Please note that this material did not form the majority of these horizons, thus it was only described and recorded in field notes and not assigned the subscript “b”. Interestingly, this buried A horizon occurred within a densic horizon; CWRF 201-2, located under a topsoil treatment at a depth of 19 cm in the north east corner of the plots. Additionally, the majority of pedons with prominent topsoil material also occurred in the upper northeast section.

Bw horizons were observed within at least nine profiles, five of which were considered cambic (Table 21). It is important to point out that a subsoil horizon that exhibits evidence of alteration may be labeled as Bw without necessarily being cambic. According to Soil Survey Staff (2006), a cambic horizon should be approximately 15 cm or more thick, have a texture of (loamy) very fine sand or finer, show evidence of alteration either by meeting all aquic conditions listed in Soil Survey Staff (2006), or have soil structure within more than one-half of the layer’s volume and a higher chroma and value or higher clay content of the underlying or overlying horizon. Finally, the layer cannot meet the properties listed for epipedons such as mollic, umbric, etc., and may not be part of the plow layer (Ap).

Table 21 – Important taxonomic soil profile characteristics including Bw, densic layers, strong Sulfidic odor, etc.

	Pit ID	Treatment	Number of Profiles per each Treatment
Bw Horizons	102-3, 104-5, 202-1, 203-3, 204-3, 301-3, 302-3, 303-2, 404-1	102 – Bio CT 104 – Topsoil 203 – Control 204 – Bio CT 301 – Bio NT 302 – Bio CT 303 – Topsoil 404 – Bio-NT	Bio NT – 3 Bio CT – 3 Topsoil – 2 Control – 1
Densic Layer	201-2, 203-3, EC 5-2, EC 7-2, EC 11-2	201 - Topsoil 203 – Control EC – Compacted Area	Topsoil - 1 Control – 1 Compacted Area - 3
Buried A Horizon	201-2	201 – Topsoil	Topsoil – 1
Water Table	104-5, 202-1, 204-3, 304-1, 403-5, EC 7-2, EC 12-2	104 – Topsoil 202 – Bio NT 204 – Bio CT 304 – Control 403 – Bio CT EC – Compacted Area	Bio NT – 1 Bio CT – 2 Topsoil - 1 Control – 1 Compacted Area – 2

3.6.4 Rooting Distribution

All of the sampled mine soils were vegetated with a *Glycine max* crop at the time of description and sampling. There were no treatment, block or block*treatment interaction effects for the experiment with respect to rooting. Additionally, individual contrast statements between the Compacted Area and the CWRP indicated no differences between mean depths to detectable rooting observed from detailed root counts taken in the soil pits. Plant roots penetrated to an average depth of 62 cm (24 inch) across all four treatments, with Bio-NT soils supporting the deepest rooting (although non-significant) to 75 cm (30 inches) followed closely by the Bio-NT and Control at 67 cm (26 inches) and 59 cm (23 inches), respectively. The Topsoil treatment soils supported the shallowest overall rooting depth of 48 cm (19 inches). These are simple

averages based on detailed soil pedon descriptions (Appendix H). Depth to rooting for the CWRF and Compacted Areas are shown in Table 22.

Table 22 – Mean depth to detectable rooting by treatment in soil pits at the Carraway-Winn Reclamation Research Farm (Summer 2006) and external comparison areas. Values within columns followed by the same letter are not different ($p \leq 0.05$).

Treatment	Depth (cm)	Depth (inch)
Bio-CT	67a	26a
Bio-NT	75a	75a
Control	59a	23a
Topsoil	48a	19a
Compacted Area	64	25

Overall rooting was common and generally well-dispersed rooting across all four treatments as described above. Within eight pits, CWRF 101-4 (Bio-NT), 102-3 (Bio-CT), 103-2 (Control), 201-2 (Topsoil), 302-3 (Bio-CT), 304-1 (Control), 403-5 (Bio-CT), and 404-1 (Bio-NT), plant roots occurred in concentrated masses along desiccation cracks (Figs. 36 and 37). Given that root masses were more obvious on the longer expression of the North and South pit faces and not the West pit face used for profile descriptions, many of these root masses were not described in detail; however, they were described in field notes and photographed at each pit (Appendix H).



Figure 36. Root masses along desiccation cracks. Notice how roots are concentrated in large vertical cracks around clayey polygons. This photo was taken from the southern face of CWRP 104-5. The prominent desiccation cracks seen here most likely resulted from the drying and desiccation of relatively pure layer of slimes deposited over the very pure tailings seen at depth during pit dewatering. Additional contrasting coarser materials were then placed over the desiccated slimes layer; a common practice in this mining operation.

This cracking behavior is commonly observed on the surface of dewatering mine pits as slimes dry out and bake in the sun. The process is particularly evident and accelerated when the slimes layer lies abruptly over sandy tailings as shown here in Fig. 36. Whether or not similar cracking occurs within the soil profile as it dewateres after grading with time, or if these are relicts of when the materials were exposed to the atmosphere has not been determined, but the development of polygonal cracking systems is always observed in the field as layers of slimes dewater and dry in the open atmosphere as pits are dewatered.



Figure 37. Root masses along desiccation cracks exposed after soil pit was excavated. This was high slimes C horizon material that had obviously dewatered and consolidated over time, leading to the development of large polygonal structural units.

3.6.5 Soil Chemical Properties of Detailed Study Pedons

Surface soils (Ap) were dominantly neutral to mildly alkaline with pH values ranging from 6.24 to 7.97 and an average surface soil pH of 7.32 across all treatments (Tables F-4 & F-5). Total carbon content ranged from 0.32 to 1.04 % and varied by treatment as discussed earlier. Higher levels of TC (> 0.7 %) were noted in seven of the 20 ^Ap horizons with the majority (five) located in the Bio-CT and Bio-NT treatments.

Subsurface horizons were composed of two highly variable materials, primarily sandy tailings, and clayey slimes (Orndorff et al, 2005). Subsurface horizons were slightly acidic to neutral, and ranged from pH 4.68 to 7.68 with an average subsoil pH of 5.45 across all four

treatments. Higher soil pH was more common within the Control and Topsoil treatments than in the two biosolids treatments (Tables F-4 & F-5). Near neutral pH values in several treatments at less than 30 cm were most likely the result of liming through additions of agricultural lime and lime stabilized biosolids. It is interesting to note that a few of the subsoils within the Control treatments had a higher pH. There appeared to be no correlation between lower subsoil pH values and soil reconstruction treatments in the pedon study data set. The most acidic soil occurred in EC 12-2, a Compacted Area treatment, with an average (multiple horizons within one pedon) subsurface soil pH of 4.88 (Table 23).

Table 23 – Mean surface and subsurface soil pH values for the CWRP and Compacted Area soil pedon samples (2006). Values within columns followed by the same letter are not different ($p \leq 0.05$). Subsurface values (a combination of all pedons within one soil pit) in bold face are different from their overlying surface values ($p \leq 0.05$).

Treatment	Average Surface Soil pH	Average Subsurface Soil pH
Bio-NT	7.75a	5.37ab
Bio-CT	7.78a	5.29ab
Control	7.23b	5.71a
Topsoil	7.07b	5.66ab
Compacted Area	6.79	5.20

Individual contrasts indicated that the average surface pH for the Compacted Area was lower than the average surface pH values for all four soil reconstruction treatments ($p < 0.045$); however it was not significantly different in subsurface pH value.

Subsoil TC, ranged from 0.014 % to 3.00 % with the highest TC under the Control treatment and the lowest TC under the Bio-NT. It is interesting to note that two of the 20 profiles, both Control pedons, had subsoil TC greater than 1.0 %. Additionally, three of the 20 profiles exhibited an irregular (nonlinear) decrease to 0.2% TC between 25 and 125 cm, the

particle control section for most profiles. Of the 17 remaining profiles, none exhibited an irregular decrease to 0.2% of TC in their subsoils.

3.6.6 Soil Classification

Four of the 20 profiles were classified (Soil Survey Staff, 2006) as an Udifluvents, five as Dystrudepts, and eleven as Udorthents (Table 18). A Fluvent is an Entisol, with no densic, lithic or paralithic contact with either 0.2 % or more organic carbon or an irregular decrease (0.2 %) in the carbon content of the subsoil. Udifluvents occur in the udic (humid like Virginia) soil moisture regime. Orthents are Entisols that do not express any other characteristics of other Entisol soils. Udorthents also occur in the udic soil moisture regime. Udepts are Inceptisols, or soil exhibiting at least one pedogenically well-developed A or B horizon, in a udic moisture regime that do not express any other characteristics of an Inceptisol. A Dystrudept is an udept that does not express any other characteristics of Udepts. An aniso particle size class occurs if the particle size control section (usually 25 to 100 cm for most soil profiles) includes more than one pair of strongly contrasting classes and it is named for the pair of adjacent classes that contrasts most strongly--e.g. sandy over clayey, coarse-loamy over sandy, etc (Soil Survey Staff, 2006).

IV. SUMMARY AND CONCLUSIONS

The Carraway-Winn Reclamation Research Farm was established in 2004 to evaluate the effectiveness of various soil reconstruction techniques on mineral sands mine soil physical and chemical characteristics and associated row crop productivity. This specific research program focused on the row-crop soil reconstruction experiment, an untreated compaction study

bordering the row-crop plots, and an external unmined control area located at the Clarke Farm under similar management. The Clarke Farm control allowed a comparison between soil physical and chemical properties of native unmined soils to young mine soils ameliorated with various soil reconstruction techniques. Similarly, the adjacent Compacted Area served as a means to determine whether the deep ripping technique employed had any net positive effects on mine soil strength, bulk density and row crop productivity.

The reconstructed mine soil Control treatment produced higher corn yields (+54%) in 2005 than a five-year-county-average for Dinwiddie, Virginia. However, the Control produced significantly lower yields than the two Biosolids treatments (Bio-CT and Bio-NT treatments respectively). The Topsoil return treatment produced significantly lower corn yield (-32%) than the five-year-county-average and the other three reconstruction treatments due to several interacting factors. First of all, surface and subsurface soil pH were lower in the Topsoil treatment (5.68 and 5.00 respectively); most likely due to the lime not fully reacting, or perhaps being under-applied. The Topsoil treatment's low pH was a result of low quality topsoil taken from a forested site. Additionally, the Topsoil treatment was significantly lower in surface soil available P compared to the two biosolids treatments and Clarke Farm control. This was most likely due to P-fixation. Finally, combined physical problems of a silt crust, which formed due to heavy rains after planting, coupled with significant grading-related soil compaction, also appeared to directly limit both corn growth and overall rooting depth.

The Clarke Farm, under identical management conditions to the four mine soil reconstruction techniques, produced 159 % more corn grain than the five-year-county-average, and +32 %, +32 %, +137 % and +279 % more than the Bio-CT, Bio-NT, Control and Topsoil treatments respectively. Additionally, the adjacent Compacted Area that did not receive the

deep-ripping protocol produced 9 % more corn grain than the five-year-county-average and 41% more than the Topsoil treatment. In fairness, however, we must reiterate the fact that we irrigated our corn crop while the county average data are based upon non-irrigated and irrigated corn.

In 2006, all four mine soil reconstruction treatments produced significantly higher wheat yields than the five-year-county-average; (Bio-NT - +48 %; Bio-CT - +27 %; Topsoil - +20 %; and Control - +14 %), respectively. In comparison, the Clarke Farm produced significantly higher wheat yields than all four soil reconstruction treatments, and 92 % more than the five-year-county-average. The Compacted Area produced significantly higher wheat yields (+20 %) than the five-year-county-average; however, unlike the corn yields in 2005, it did not out-produce the Topsoil treatment. The increase in Topsoil productivity in 2006 was most likely due to the fact that the Topsoil plots were chisel-plowed and disked to alleviate soil compaction and crusting after the 2005 harvest.

There was a significant difference ($p < 0.03$) in total observable rooting depth between the two Biosolid treatments and the Topsoil and Control reconstruction techniques. Total depth of visible rooting was deepest within the two Biosolid treatments, followed by the Control and Topsoil treatments respectively. Individual contrasts between the Clarke Farm and the four soil reconstruction techniques indicated no difference in rooting depth between the Clarke farm and the two Biosolid treatments. This lack of observable difference in rooting depth may have been a result of insufficient field observations, however, and more studies would need to be conducted to determine the detailed rooting distributions between the Clarke Farm and the two Biosolids treatments. Given the above observations, mean root counts at a set depth of 42 cm were compared for a more consistent contrast of rooting across all treatments and study sites. There

was a significant increase in rooting density for the Bio-NT vs. the Bio-CT treatments, Control and Topsoil treatments within the row crop experiment. This was one of the few variables where the two Biosolid treatments differed significantly from each other. Although the Topsoil treatment did not appear to be significantly different from the Bio-CT and Control treatments in rooting, it was significantly different from the Bio-NT, Clarke Farm and Compacted Areas. This 'lack of rooting' beneath the Topsoil treatment was most likely a result of mechanical compaction and high soil strength caused during topsoil return and grading. The Bio-NT treatment was not significantly different than the Clarke Farm or the Compacted Area.

Compaction has been reported as the major soil factor limiting crop yields on coal mine soils recreated on prime farmlands in the Mideastern and Midwestern USA (Jansen, 1981, Barnhisel and Gray, 1990). Bulk densities as high as 1.8 g/cm^3 are common among compacted mine soils, and the mine soils at Old Hickory studied here were no exception, with bulk densities of $\geq 1.7 \text{ g/cm}^3$ commonly occurring. Although the plots were deep ripped along two perpendicular passes and organic matter was added to the Biosolids treatments, surface soil bulk density varied little by treatment. There was a significant treatment effect ($p < 0.01$) and a significant block*treatment ($p < 0.01$) interaction with respect to bulk density. The two Biosolids treatments had the lowest surface bulk density, followed by the Control and Topsoil treatments respectively. In a similar study conducted by Stolt et al. (2001), mine tailings amended with yardwaste compost had greater porosity and water holding capacity, thus causing lower mechanical resistance and lower bulk density than unamended tailings. Therefore, the two Biosolids treatments would be expected (and did) exhibit lower bulk densities than both the Control and Topsoil treatments.

Linear regression comparing D_b against point corn and wheat yields within each measured yield strip showed little to no correlation between D_b and yield for either crop; R^2 values were < 0.1 for both crops for three models (linear, cubic, and quadratic). Due to concerns over whether we could reliably interpret bulk density data due to heavy mineral inclusions, particle density analysis was performed on a subset of samples ($n = 10$) and results fell within typical limits of 2.65 to 2.7 g/cm^3 with the exception of one sample. Thus, the conventional interpretations of relative bulk density ranges were valid for these mine soils.

Given that there was no correlation between surface bulk density and crop yield, we subsequently looked at soil strength via analysis of penetrometer data. Pairwise t-test contrasts suggested that there were no significant differences between surface soil strength among all four soil reconstruction techniques.

Surface and subsurface pH values varied among all four soil treatments, with the two Biosolid treatments having higher surface soil pH (Bio-NT pH 7.21 and Bio-CT pH 7.10), while the Topsoil treatment had the most acidic surface (pH 5.68) in 2005. It is interesting to note that the Topsoil treatment, which had a prescribed application of lime at 9 Mg/ha, had similar surface (5.68) and subsurface (5.00) pH values to the Clarke Farm (5.82 and 5.86 respectively), but substantially lower crop yields. Subsurface pH values were also significantly lower (approx. 2 pH units) than their overlying surface soil values for the two lime stabilized Biosolids treatments, with a minimal drop between surface and subsurface pH values for the Topsoil treatment (-0.68 units) due to the lower quality topsoil. The Clarke Farm had similar surface soil and subsurface pH values which were significantly lower than the two Biosolids treatments and the Control for surface pH. Additionally, all four soil reconstruction techniques had similar subsurface pH values which were similar to those of observed at the Clarke Farm and the Compacted Area.

Thus, it appears that via differential analysis of the CWRP and Clarke Farm data sets, that soil pH per se was not as important in controlling net soil productivity as other physical factors such as bulk density and poor subsoil aggregation.

Detailed description and classification of 20 pedons from soil pits on the CWRP in the summer of 2006 revealed three different subgroup level soil classifications: 1) Typic Udorthents (n=11); 2) Typic Udifluvents (n=4) exhibiting an irregular decrease in total carbon content with depth; and 3) Typic Dystrudepts (n=5) exhibiting pedogenically altered cambic subsoil (Bw) horizons. Significant root masses were noted within desiccation cracks in eight of the 20 profiles with multiple ^Ap1 and ^Ap2 horizons described in eight profiles. Rounded macro structure (2 profiles), and convoluted banding (3 profiles) similar to that described by Orndorff et al. (2005) were also observed. Deposition of tailings and heavy mineral sands material that were described as “lamellae-like” (4 profiles), buried A (Ab) horizons (1 profiles), densic layers (5 profiles), human influenced artifacts (3 profiles), ripper traces (2 profiles) and a thin wood ash layer (1 profile) were also noted. Additionally, the majority of pedons appeared to have some topsoil-like material evident throughout various sub-horizons; however, this material did not compose enough of a horizon to warrant being described as an Ab horizon. The average depth to the observed water table was ≥ 1 m from the surface in the summer of 2006 in all pedons.

Surface horizons, which were generally sandy clay loams to sandy loams, exhibited little overall variation in gross morphology other than where topsoil had been applied. Surface horizons were typical described as multiple ^Ap horizons (e.g. ^Ap1 over ^Ap2 ; 8 profiles), with colors ranging from olive brown to strong brown, and weak to moderate and granular to subangular blocky structure. Surface soils were dominantly neutral to mildly alkaline with a total C ranging from 0.32 to 1.04%. Subsurface soil materials, which consisted mostly of layered

clay slimes and sandy tailings, varied much more widely among and within profiles, but all pedons showed at least two strongly stratified layers of contrasting tailings and slimes. Dominant colors were strong brown, with a range of distinct, prominent and faint color variegations evident. Redoximorphic color features were not observed, however, despite the fact that the lower horizons were obviously exposed to seasonal saturation.

From these combined results, I conclude that of the various reclamation methods studied, the two Biosolid treatments were superior to the Control and Topsoil treatments with respect to crop yield potentials over the first two growing seasons. Considering that the two Biosolids treatments produced 97 % higher corn yields in 2005, and that they produced significantly higher averages for wheat yields in 2006 (Bio-NT (+48 %) and Bio-CT (+27%)); either would be an appropriate method of reclamation. Conversely, it is important to point out that both treatments were essentially the same and produced relatively similar results for a majority of the variables studied. Schroeder (1997) reported similar positive results with a yardwaste compost amendment. Although Schroeder did not use the same biosolids amendments as this experiment utilized, additional research by Haering et al. (2000) in coal mining environments, confirmed that biosolids are an excellent amendment on mined lands especially where the original topsoil is either low in organic matter, or if topsoil substitution occurs such as at Old Hickory.

Although ripping effects were noted in only a few of the pits, the two Biosolids amendments produced higher corn and wheat productivity. I expect that with the current best management practices such as irrigation, liming, and ripping protocols (see Section II. Materials and Methods), coupled with biosolids additions, these reclaimed soils can be expected to produce between 70 and 80 % of local prime farmland averages. Higher relative production levels may occur once the soils equilibrate and begin to develop subsoil structure and aggregation.

Relative to expected results and the scientific literature, the overall poor performance of the Topsoil treatment here was surprising. However, given that the Topsoil used was from a forested source, I would suggest more testing is needed to see if higher-grade topsoil could significantly improve upon the results reported here. It is also possible that the relative productivity of the Topsoil treatment will improve over time due to liming and appropriate tillage and aggregation. Thus, topsoil addition success will also depend directly upon limiting the mechanical compaction caused during topsoil replacement.

Overall, based on the combined results of this experiment, I have reached the following final conclusions. First, prime farmlands at Old Hickory can be successfully returned to intensive agriculture following mineral sands mining. However, even with an extensive soil amendment and maintenance protocol, a minimum 20% decrease in average yields should be expected for highly productive pre-mine soil types. My results also indicate that salvage and reapplication of topsoil may not be the optimal soil reconstruction treatment. Conversely, the topsoil utilized in this experiment was of relatively low quality (i.e. low pH and fertility) and differing results may be apparent when higher quality agronomic topsoils are salvaged and if treatments such as the ones employed in this experiment are tracked over longer periods of time.

Although the two Biosolid treatments performed well, I feel they are not the ideal solution to Iluka's current reclamation problems. In addition to Iluka's current reclamation protocol they should consider the following: 1) Add their flocculant at the pit in addition to the thickener in order to minimize segregation of tailings and slimes and thus increase the overall homogeneity of the soil; 2) allow the soil to thoroughly dewater before driving equipment on the soil's surface in order to minimize soil compaction; 3) form the soil surface into a crown and form a more structured subsoil surface; and 4) salvage and utilize (where possible) higher quality

topsoil from the surrounding prime farmland or utilize a higher agronomic grade topsoil than was used in this experiment.

REFERENCES

- Barnhisel, R.I., and R.B. Gray, 1990. Managing restored prime farmland for corn production. pp.143-149 *In* J. Skousen et al. (Eds.) Proc., of the 1990 Mining and Reclamation Conf. and Exhibition, April 23-26, Charleston, WV. W. Va. Univ., Morgantown, WV. ASMR, 3134 Montavesta Rd., Lexington KY, 40502. <http://ces.ca.uky.edu/ASMR/>
- Barnhisel, R.I., and R. G. Darmody. 2000. Cropland reclamation. pp. 323-369. *In* Barnhisel et al. (Eds.). Reclamation of Drastically Disturbed Lands. American Soc. of Agron. Monograph #41, Madison WI.
- Barnhisel, R.I. 2006. Soil development of reclaimed prime farmland over a 20-year period. Reclamation Matters (Issue 2) 3(2):14-18. ASMR, 3134 Montavesta Rd., Lexington KY, 40502. <http://ces.ca.uky.edu/ASMR/>
- Berquist. C.R., Jr., and B.K. Goodwin. 1989. Terrace gravel, heavy mineral deposits, and faulted basement along and near the fall zone in southeast Virginia. Guidebook No. 5, Dept. of Geology, College of William and Mary, Williamsburg, VA.
- Brady, N.C., and R. R. Weil, 2003. The Elements of the Nature and Properties of Soils 13th ed. ch. 4 pp. 104-116. Prentice Hall: New York.
- Blake, G.R., 1965. Particle Density. pp. 371-373. *In* Black, C.A. (Ed.), Methods of Soil Analysis. Part II, American Society of Agronomy, Madison, Wisconsin.
- Böhm, W. 1979. Methods of Studying Root Systems. Ch. 3 pp. 5-12. Springer-Verlag, New York.
- Brooks, D.R. 2000. Reclamation of lands disturbed by mining of heavy minerals. pp. 725–754. *In* Barnhisel et al. (Eds.). Reclamation of Drastically Disturbed Lands. American Soc. of Agron. Monograph #41, Madison WI.
- Caldwell, W.E., D.A. Whitney, and J. S. Hickman. 1992. Reconstructed soil depth for rowcrop production on reclaimed prime farmland in southeast Kansas. pp. 43-49. *In* R. E. Dunker et al. (Eds.) Proc. of the 1992 Natl. Symp. on Prime Farmland Reclamation. Dept. of Agron., Univ. of IL, Urbana, IL.
- Carpenter, R.H. and S.F. Carpenter. 1991. Heavy mineral deposits in the upper coastal plain of North Carolina and Virginia. Econ. Geol. 86:1657-1671.
- Crookston, R.K., W.E. Larson, and M. Oussible, 1992. Subsurface compaction reduces the root and shoot growth and grain yield of wheat. Agron. J. 85:34-38.

- Daniels, W.L., J.C. Bell, D.F. Amos. 1981. Mapping characterization and genesis of mine soils on a reclamation research area in Wise County, Virginia. pp. 261-265. *In Proc. Symp. Surf. Mining Hydrol., Sedi. and Recl.*, Lexington, KY. 7-11 December. Office Eng. Serv., College Eng., Univ. Kentucky, Lexington, KY.
- Daniels, W.L., M.H. Genthner, and R.L. Hodges. 1992. Soil development in sandy tailings derived from mineral sands mining in Florida. pp. 37-47. *In Proc.*, 1992 Annual Meeting of the Amer. Soc. Surf. Mining and Rec., Duluth, MN., Published by IRRB, Chisolm, MN. ASMR, 3134 Montavesta Rd., Lexington KY, 40502. <http://ces.ca.uky.edu/ASMR/>
- Daniels, W.L., M.M. Alley, L.W. Zelazny, Y.Z. Lei, V.A.L. Groover and P.D. Schroeder. 1996. Strategies for rehabilitating prime farmlands following mineral sands mining in Virginia, USA. pp. 412-427. *In D. Brooks et al. (Eds.), Proc.*, (Vol 2) Third International Minerals Council of Australia Environmental Workshop, Newcastle - NSW, Oct. 14-18, Minerals Council of Australia, Dickson, ACT, Australia.
- Daniels, W.L., P.D. Schroeder, S.M. Nagle, L.W. Zelazny, and M.M. Alley. 1999. Reclamation of prime farmlands following mineral sands mining in Virginia. pp. 146-156 *In S.A. Bengson et al. (Eds.) Proc.*, 16th Annual Meeting, American Society for Surface Mining and Reclamation, August 13-19, Scottsdale, AZ. ASMR, 3134 Montavesta Rd., Lexington KY, 40502. <http://ces.ca.uky.edu/ASMR/>
- Daniels, W.L., P.D. Schroeder, S.M. Nagle, L.W. Zelazny, and M.M. Alley. 2003a. Reclamation of prime farmland following mineral sands mining in Virginia. *Mining Engineering*, Dec. 2003: 42-48.
- Daniels, W.L., Z.W. Orndorff, and P.D. Schroeder. 2003b. Chemical and physical properties of mineral sands mine soils in southeastern Virginia. pp. 209-227 *In: R.I. Barnhisel, (Ed.) Proc.*, 2003 National Meeting of the Am. Soc. of Mining and Reclamation, Lexington, KY, June 3-6, 2003, Billings, MT. ASMR, 3134 Montavesta Rd., Lexington KY, 40502. <http://ces.ca.uky.edu/ASMR/>
- DeMent, J.A., S. Cooney, and J. Denmam. 1992. Development of a prime farmland minesoil in selectively cast overburden in northeast Texas. pp. 177-181. *In R. E. Dunker et al. (Eds.) Proc. 1992 Natl. Symp. Prime Farmland Reclamation*, St. Louis, MO. 10-14 August, 1992. Dep. Agron., Univ. Illinois, Urbana.
- Donohue, S.J. and S.E. Heckendorn. 1996. Laboratory procedures: Virginia Tech Soil Testing and Plant Analysis Laboratory. *Virginia Coop. Ext. Bull.* pp. 452-881. Blacksburg, VA.
- Drew, M.C., and M.J. Gross. 1973. Effects of soil physical factors on root growth. *Chemistry and Industry*. 14:676-684.

- Dunker, R.E., C. L. Hooks, S. L. Vance, and R. G. Darmody. 1995. Deep tillage effects on compacted surface-mined land. *Soil Sc. Soc. Am. J.* 59: 192-199.
- Grandt, A.F. 1988. Productivity of reclaimed lands - cropland. pp. 1321-135. *In* L.R. Hossner (Ed.) *Reclamation of Surface Mined Lands*. CRC Press, Boca Raton, FL.
- Haering, K.C., W.L. Daniels and S.E. Feagley. 2000. Reclaiming mined land with biosolids, manures and papermill sludge. pp. 615-644 *In* R.I. Barnhisel et al. (Eds.), *Reclamation of Drastically Disturbed Lands*. American Soc. of Agron. Monograph #41, Madison WI.
- Haering, K.C., W.L. Daniels and J.M. Galbraith. 2004. Appalachian mine soil morphology and properties: Effects of weathering and mining method. *Soil Sci. Soc. Am. J.* 68:1315-1325.
- Hodges, R.L., P. J. Thomas, W.L. Daniels, M. H. Genthner, Z. W. Orndorff, and P. Donovan. 2002. Soil Survey of the Old Hickory Area, Virginia. United States Dept. of Agri., NRCS. Virginia Polytechnic Institute and State University. Blacksburg, VA.
- Hooks, C., R.E. Dunker, S.L. Vance, and R.G. Darmody. 1992. Rowcrop response to truck and scraper hauled root media systems in soil reconstruction. pp. 19-23. *In* R. E. Dunker et al. (Eds.) *Proc. of the 1992 Natl. Symp. on Prime Farmland Reclamation*. Dept. of Agron., Univ. of IL, Urbana, IL.
- Jansen, I.J. 1981. Reconstructing soils after surface mining prime agricultural land. *Mining Engineering* 33:312-314.
- Kelly, E. G. and David J. Spottiswood. 1982. *Introduction to Mineral Processing*. Colorado School of Mines. John Wiley & Sons Inc. New York.
- Lynd, L.E., and S.J. Lefond. 1983. Titanium minerals. pp. 1303-1362. *In* S.J. Lefond (Ed.) *Industrial Minerals and Rocks*. 5th ed. American Institute of Mining, Metallurgical and Petroleum Engineers. Littleton, Co.
- McSweeney, K. and I.J. Jansen, 1984. Soil structure and associated rooting behavior in minesoils. *Soil Sci. Soc. Am. J.* 48:607-612.
- Milnes, A. R., and R.W. Fitzpatrick. 1989. Titanium and zirconium minerals. pp. 1131-1205. *In* *Minerals in Soil Environments*, 2nd ed. J.B. Dixon and S.B. Weed (Eds.). Soil Sci. So. Am. Book Series 1, SSSA, Madison, WI
- Orndorff, Z. W., W.L. Daniels, and J.M. Galbraith. 2005. Properties and classification of mineral sands mine soils in southeastern Virginia. pp. 842-861. *In* R. I. Barnhisel, (Ed.) *Proc., 2005 National Meeting of the Am. Soc. Of Mining and Reclamation*, Breckenridge, CO, June, 19-23, 2005. ASMR, 3134 Montavesta Rd., Lexington KY, 40502. <http://ces.ca.uky.edu/ASMR/>

- Pearson, Robert W. 1974. Significance of rooting pattern to crop production and some problems of root research. pp. 247-270. *In* E.W. Carson (Ed.) *The Plant Root and Its Environment*. Univ. Press of Virginia, Charlottesville.
- Pedersen, T.A., A.S. Rowgowski, and R. Pennock, Jr. 1980. Physical characteristics of some mine soils. *Soil Sc. So. Am. J.* 44:321-328.
- Phillips, R.E. and D. Kirkham. 1962. Mechanical impedance of corn seedling root growth. *Soil Sci. Soc. Am. Proc.* 26:319-322.
- Powell, J.L., R.I. Barnhisel, F.A. Craig, J.R. Armstrong, M.L. Ellis, and W.O. Thom. 1986. The use of organic amendments in the restoration of prime farmland. pp. 55-60. *In* Harper, J., and W.T. Plass (Eds.) *Proc. Natl. Meeting Am. Soc. Surface Mining and Reclamation*, Jackson, MI. 17-20 Mar 1986. ASMR, 3134 Montavesta Rd., Lexington KY, 40502. <http://ces.ca.uky.edu/ASMR/>
- SAS. 2004. SAS System for Windows, Version 9.1.2, SAS Institute Inc., Cary, NC.
- Schroeder, P.D. 1997. Restoration of Prime Farmland Disturbed by Mineral Sand Mining in the Upper Coastal Plain of Virginia. M.S. Thesis, Virginia Tech, Blacksburg, 164 pp.
- Sencindiver, J.C., and J.T. Ammons, 2000. Minesoil genesis and classification. pp 595-613. *In* R. I. Barnhisel et al. (Eds.) *Reclamation of Drastically Disturbed Land*. American Soc. of Agron. Monograph #41, Madison, WI
- Shepherd, M.S. 1986. Australian heavy mineral reserves and world trends. pp. 61-68. *In* Australia: A World Source of Ilmenite, Rutile, Monazite and Zircon. Australasian Inst. Mining Metallurgy, Perth.
- Smith, P.L., E.F. Redente, and E. Hooper. 1987. Soil organic matter. pp. 185-214. *In* R.D. Williams and G.E. Schuman (Eds.). *Reclaiming Mine Soils and Overburden in the Western United States: Analytical Parameters and Proceedings*. Soil Conserv. Soc. Am., Akeny, IA.
- Soil Survey Staff. 2006. Keys to Soil Taxonomy. 10th ed. USDA-NRCS, Washington, DC. http://soils.usda.gov/technical/classification/tax_keys/keys.pdf
- Soil Survey Staff. 1993. Soil Survey Manual. USDA-SCS Agric. Handbook 436. U.S. Gov. Print Office, Washington, D.C.
- Sopper, W.E., and S.N. Kerr. 1982. Mine land reclamation with municipal sludge-Pennsylvania's demonstration program. pp. 55-74 *In* W.E. Sopper et al. (Ed.) *Land Reclamation and Biomass Production with Municipal Wastewater and Sludge*. Pennsylvania State Univ. Press, Univ. Park, PA.

- Stolt, M.H., J. C. Baker, and T. W. Simpson, 1991. Bucket auger modification for obtaining undisturbed samples of deep saprolite, *Soil Sci.* 151:179-182.
- Stolt, M.H., J.C. Baker, T. W. Simpson, D. C. Martens, J. R. McKenna, and J. R. Fulcher. 2001. Physical reconstruction of mine tailings after surface mining mineral sands from prime agricultural land. *Soil Sci.*, 166:29-37.
- Taylor, M., and H. R. Gardner. 1963. Penetration of cotton seedling taproots as influenced by bulk density, moisture content, and strength of soil. *Soil Sci.*, 96:153-156.
- Taylor, M., and E. Burnett. 1964. Influence of soil strength on the root-growth habits of plants. *Soil Sci.* 98:174-180.
- Thomas, G.W. 1996. Soil pH and soil acidity. p. 475-490. *In* D.L. Sparks (Ed.) *Methods of Soil Analysis, Part 3. Chemical methods.* SSSA Book Series # 5. SSSA-ASA, Madison, WI.
- Thompson, P.J., I.J. Jansen, and C.L. Hooks. 1987. Penetrometer resistance and bulk density parameters for predicting root system performance in mine soils. *Soil Sci. Soc. Am. J.* 51:1288-1293.
- Thurman, N.C., J.C. Sencindiver, J.T. Ammons and D.C. Adamo. 1985. Physical properties of minesoils and their effects on root growth. pp. 194-208. *In* Proc. 5th Better Reclamation with Trees Conf., Carbondale, IL. 5-7 June. Dept. Bot., South. Illinois Univ., Carbondale, IL.
- USDA-NRCS. 2004. Soil Survey Laboratory Methods Manual. Soil Survey Investigations Report no. 42, Version 4.0. U.S. Dept. of Agric., Nat. Res. Cons. Svc., Natl. Soil Surv. Ctr. Lincoln, NB.
ftp://ftp-fc.sc.egov.usda.gov/NSSC/Lab_Methods_Manual/SSIR42_2004_view.pdf
- Vance, S.L., R.E. Dunker, C.L. Hooks, and R.G. Darmody. 1992. Relationship of Soil Strength and Rowcrop Yields on Reconstructed Surface Mine Soils. pp. 35-42. *In* R. E. Dunker et al. (Eds.) Proc. of the 1992 Natl. Symp. on Prime Farmland Reclamation. Dept. of Agron., Univ. of IL, Urbana, IL.
- Walker, J.M. 1994. Production, use and creative design of sewage sludge biosolids. pp. 67-74. *In* C.E. Clapp et al. (Eds.) *Sewage Sludge: Land Utilization and the Environment.* SSSA Misc. Publ. ASA, CSSA, and SSSA, Madison, WI.
- Wells, L.G., and R.I. Barnhisel, 1992. Bulk density response to placement methods and remedial measures to reconstructed prime farmland soils. pp. 213-219. *In* R. E. Dunker et al. (Eds.) Proc. 1992 Natl. Symp. Prime Farmland Reclamation, St. Louis, MO. 10-14 August. Dep. Agron., Univ. Illinois, Urbana.
- Witsell, L.E., and J.A. Hobbs. 1965. Soil compaction effects on field plant growth. *Agron. J.* 57:534-537

Zhai, Q. and R.I. Barnhisel. 1996. A reclamation approach for mined prime farmland by adding organic wastes and lime to the subsoil. pp. 740-748. *In* W.L. Daniels, et al. (Eds.) Successes and failures: applying research results to insure reclamation success. Proc. Amer Soc. for Surface Mining and Reclamation, Knoxville, TN. 18-23 May 1996. ASMR, 3134 Montavesta Rd., Lexington KY, 40502. <http://ces.ca.uky.edu/ASMR/>

Appendices

APPENDICES	117
<i>Appendix A - Flowcharts of the Wet and Dry Mill Processes and Pertinent Mining Terms</i>	118
<i>Appendix B - Detailed Plot Installation Procedures</i>	126
<i>Appendix C – Analysis of Lime-stabilized Biosolids (Arlington, VA) used in the Bio-CT and Bio-NT Treatments at the Carraway-Winn Reclamation Research Farm</i>	129
<i>Appendix D - Initial Soil Sampling (Fall 2004)</i>	132
<i>Appendix E - Auger Soil Sample Data (Summer 2005)</i>	137
<i>Appendix F - Auger Profile Descriptions for the Carraway-Winn Reclamation Research Farm (Summer 2005)</i>	142
<i>Appendix G - Soil Pit Sample Data (Summer 2006)</i>	186
<i>Appendix H – Soil Profile Descriptions for the Carraway-Winn Reclamation Research Farm and Clarke Farm Soil Pits (Summer 2006)</i>	195
VITA	216

Appendix A
Flowcharts of the Wet and Dry Mill Processes and
Pertinent Mining Terms

Appendix A – 1. Mining/Mineral Processing Terms Defined. Please note that all definitions are Adapted from “Introduction to Mineral Processing” (*Kelly, 1982*).

1. Acid Leach Circuit - Ore is mechanically agitated and leached with sulfuric acid and sodium chlorate and then sent to the Zircon Roughers (See Rougher).
2. Attritioners - (A.K.A. Scrubber) A machine that removes the coatings of mineral sands.
3. Cleaner - Rougher concentrate is sent to the “Cleaner” which is a machine that “cleans” the ore in order to increase grade. Sometimes “Recleaners” may be necessary depending upon requirements.
4. Concentrate - A product containing valuable ore where most of the waste material within the ore has been eliminated.
5. Cyclones - A type of separator that uses rotational effects and gravity to separate mixtures of solids and fluids via varying densities. Heavier material is flung to the outside edge of the spiral while lighter material is concentrated in the center.
6. Hydrosizers - A tank where ore is subjected to a “sorting effect” from a stream of hydraulic water. Heavier/coarser particles gravitate down and away while lighter materials are carried up and out.
7. Magnet - Two types of magnetic separation equipment (low intensity and high intensity magnetic separators). Both magnetic separators may be carried out either wet or dry. For Iluka’s purposes, magnetic separation is performed on dry material.
8. Mids - (Midlings) Are the unliberated particles.
9. Mining Unit - A machine that crushes and grinds ore for the purposes of mineral processing.
10. Overflow - (O/F, Undersize) The flow stream that contains slower settling particles (negative response stream).
11. Rougher - (First Stage) A machine that removes the edasily recoverable ore as a rougher concentrate. Tailings are then sent to the Scavenger.
12. Trommel (Screens) - A screened cylinder used to separate materials by size.
13. Scavenger - (Second Stage) A machine that extracts the remaining (economically viable) ore from the rougher tailings.
14. Scalper - A machine that removes a small amount of oversize material from the feed (predominantly fines).
15. Scrubber - A chemical or physical device used to remove waste compounds formed during the mineral process.
16. Slimes - A waste stream that consist of finer silt and clay-sized materials.
17. Slurry - Fine solid particles that have been suspended in liquid (usually water) that allows flow via gravity or pumping.
18. Stacker - Is used to form a conical shaped stockpile.
19. Stockpile - A pile of coarse ore concentrate that is stored at the “angle of repose” for save concentrate.
20. Sump - The bottom of the mining pit/area used as a collecting point for drainage water.
21. Tailings - A waste stream that consists of the coarser sand-sized materials.
22. Tails Cut (Tails) – (TC) See also tailings materials.
23. Underrflow - (U/F, Oversize) The flow stream that is generally low in water and contains the faster settling particles (positive response stream).

Appendix A-2. Flowchart 2 (Page 1). Flowchart of Iluka’s current wet mill procedures. The terms MC, PC, and TC refer to primary cut, medium cut and tails cut respectively.

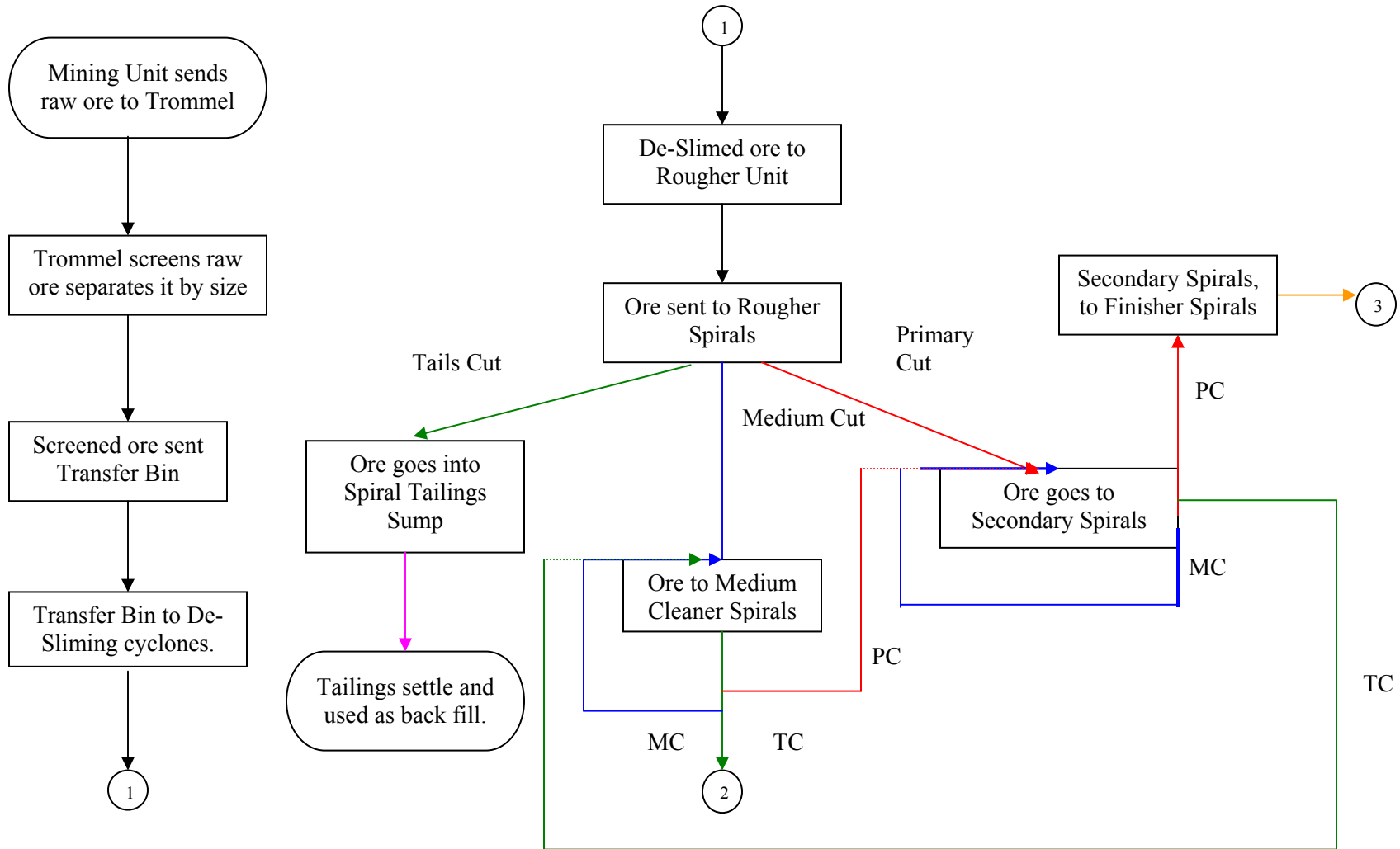

Appendix A-2 Cont'd. Flowchart 2 (Page 2). Flowchart of Iluka's current wet mill procedures.

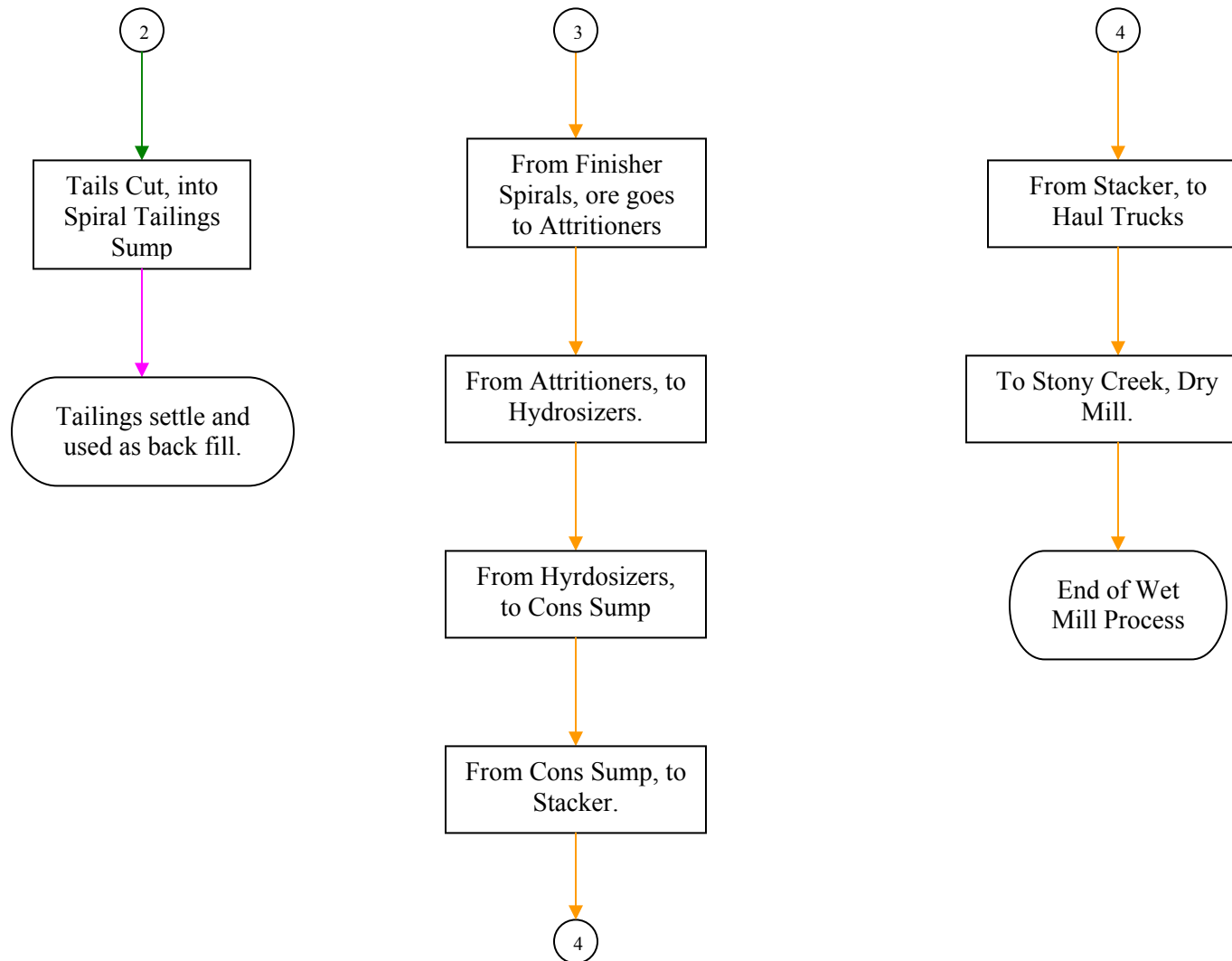

Appendix A-3. Flowchart 3 (Page 1). Flowchart of Iluka's current dry mill procedures.

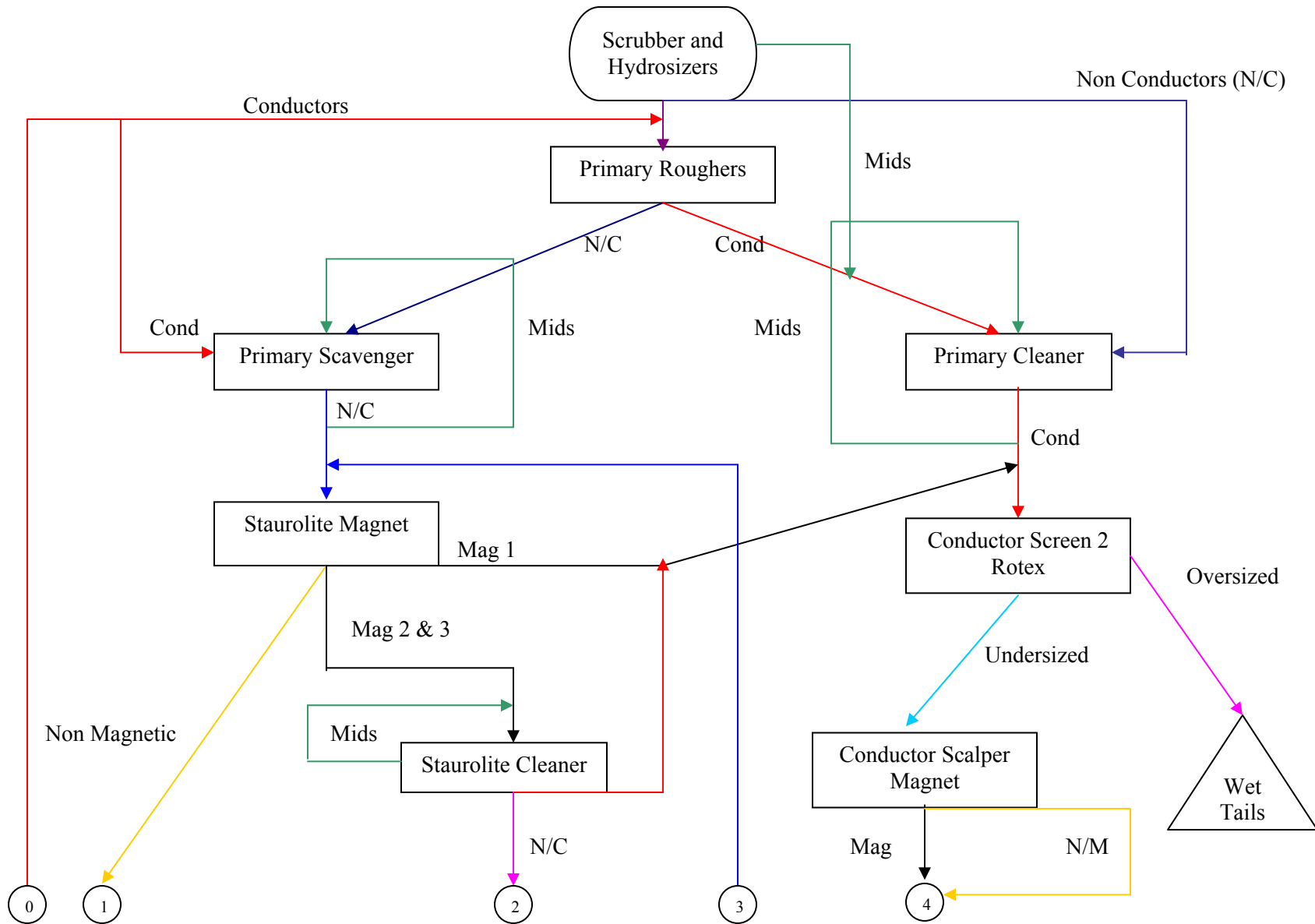

Appendix A-3 Cont'd. Flowchart 3 (Page 2). Flowchart of Iluka's current dry mill procedures.

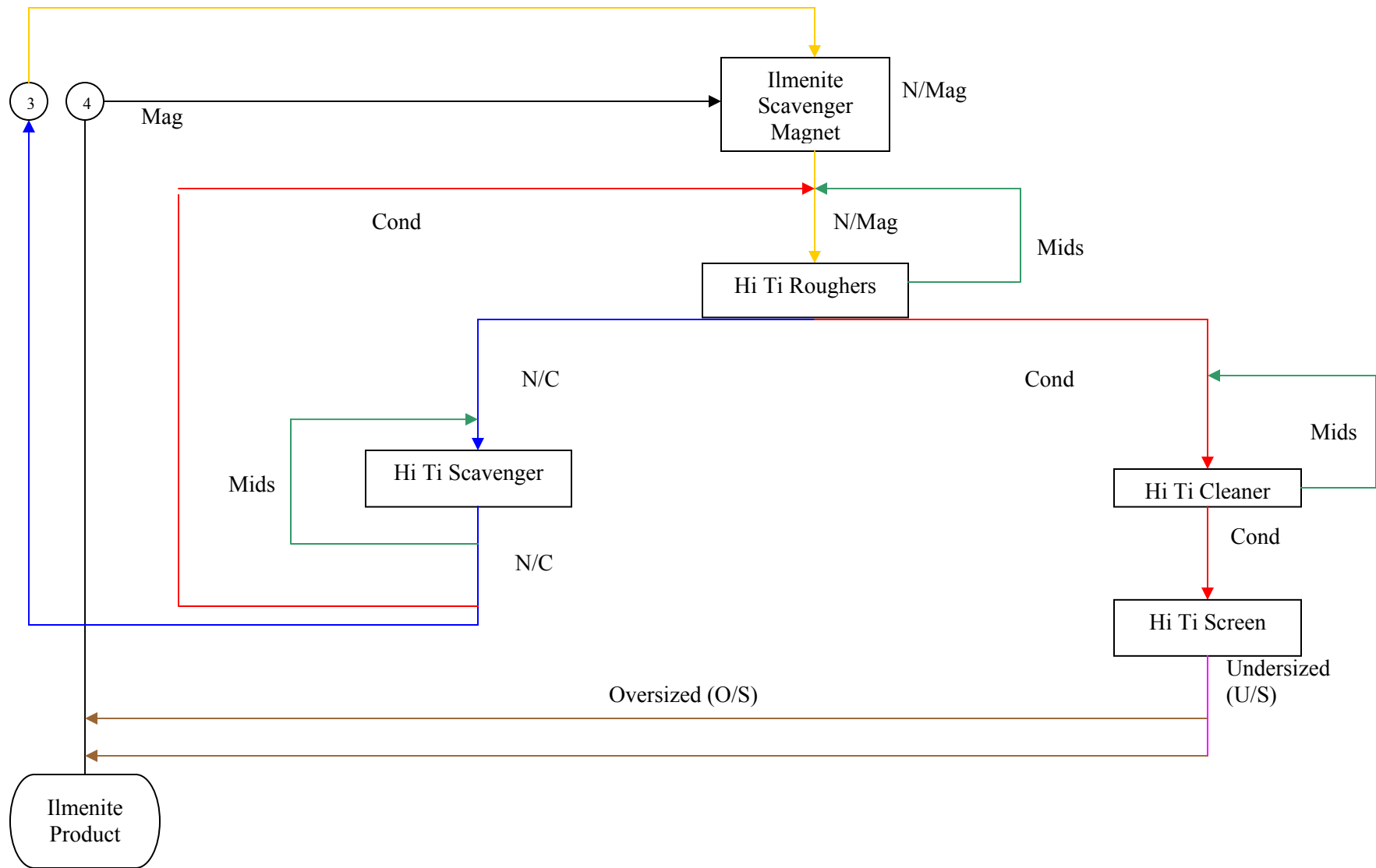

Appendix A-3 Cont'd. Flowchart 3 (Page 3). Flowchart of Iluka's current Dry Mill procedures.

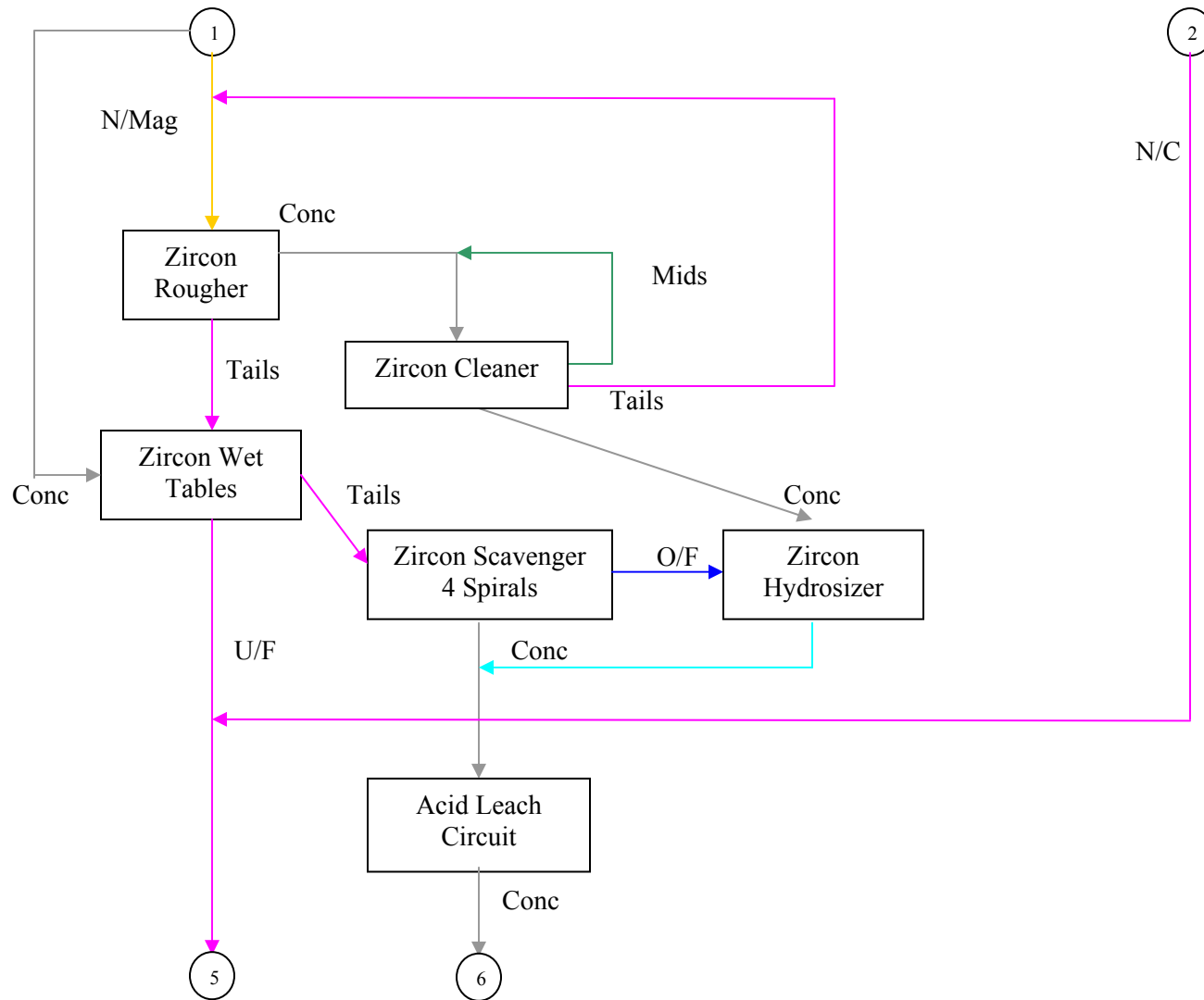

Appendix A-3 Cont'd. Flowchart 3 (Page 4). Flowchart of Iluka's current dry mill procedures. Please note that the term 'wet tails' refers to the process by which wet tailings material is returned to 'Old Hickory' as 'dry mill tails' and back-filled into the mine pits.

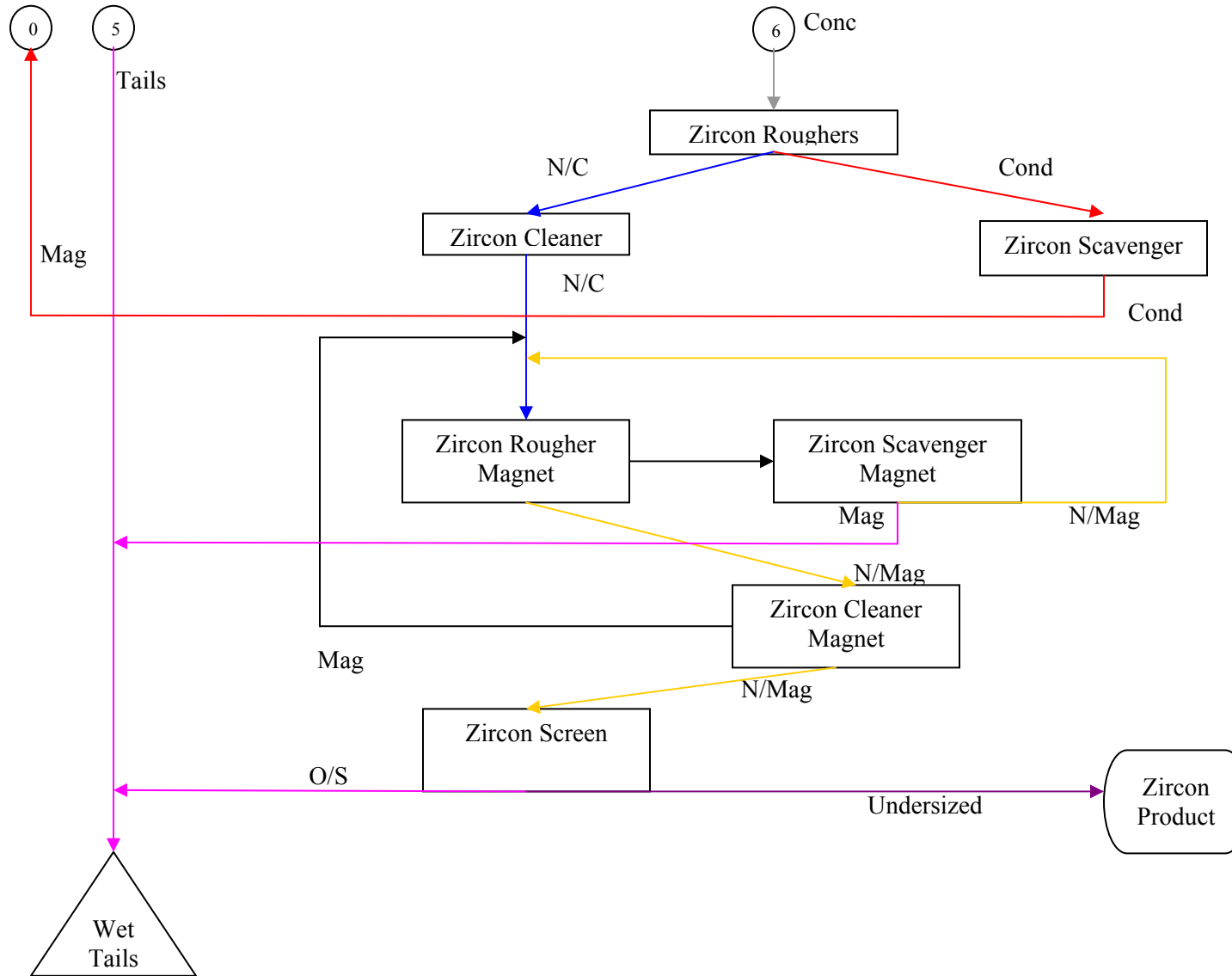

Appendix B

Detailed Plot Installation Procedures

Table B-1 – Chronology of soil amendments for the CWRP, Compacted Area, and Clarke Farm Control. Please note that this table only includes additions of lime, fertilizer, and biosolids and does not include any tillage, deep ripping or irrigation. CWRP applies to all plots within the row crop experiment.

Year	Month	Day	Work Completed	Location
2004	9	27	Round-Up Ultra (2.2 L/ha) 2-4-D (1.2 L/ha)	CWRP Compacted Area
2004	11	3	Lime (9 Mg/ha) P 674 kg/ha P ₂ O ₅	Topsoil Control
2004	11	17 19	Biosolids applied at 78 Mg/ha by Synagro Inc. (Appendix B)	Bio CT Bio NT
2004	11	22	Lime (6.7 Mg/ha)	Topsoil
2005	11	3	Lime (4.5 Mg/ha)	Topsoil
2005	11	3	Lime (2.2 Mg/ha)	Clarke Farm
2005	11	3	393 kg/ha of 11-23-23 dry fertilizer	CWRP Compacted Area Clarke Farm
2006	1	30	187 L/ha of 1-30-06 (30% liquid N) UAN	CWRP Compacted Area Clarke Farm
2006	3	28	140 L/ha of 1-30-06 (30% liquid N) UAN	CWRP – ex. Biosolids Compacted Area
2006	5	14	Headline fungicide (5.6 kg/ha) Karate insecticide (1.7 kg/ha)	CWRP Compacted Area Clarke Farm

Table B-2 – Chronology of soil irrigation for the CWRP, Compacted Area, and Clarke Farm.

Year	Month	Day	Work Completed	Location
2005	6	11 12	20-cm of Water (2 and 1/3 passes*)	CWRP Compacted Area
2005	6	16	20-cm of Water (1 pass)	CWRP Compacted Area
2005	6	17	20-cm of Water (2 passes)	CWRP Compacted Area Clarke Farm
2005	6	22	20-cm of Water (1 pass)	CWRP Compacted Area
2005	6	23	20-cm of Water (1 pass)	CWRP Compacted Area Clarke Farm
2005	6	24	20-cm of Water (1 pass)	CWRP Compacted Area
2005	7	7	20-cm of Water (1 pass)	CWRP Compacted Area Clarke Farm
2005	7	21	20-cm of Water (2 passes)	CWRP Compacted Area Clarke Farm
2005	7	22	20-cm of Water (1 pass)	CWRP Compacted Area
2005	8	4	20-cm of Water (1 pass)	CWRP Compacted Area
2005	8	5	20-cm of Water (1 pass)	CWRP Compacted Area
2005	8	6	20-cm of Water (1 pass)	CWRP Compacted Area

* One full pass is equivalent to 1/3 of the Crop Plots.

Appendix C
Analysis of Lime-stabilized Biosolids (Arlington,
VA) used in the Bio-CT and Bio-NT Treatments at
the Carraway-Winn Reclamation Research Farm

Report Number:
2004-R339-033

A&L EASTERN AGRICULTURAL LABORATORIES, INC.

7621 Whitepine Road • Richmond, Virginia 23237 • (804) 743-9401
Fax No. (804) 271-6446



Lab Number:
44116 Page 1

Account Number:
74660

Samples Submitted By:
BRYAN CAUTHORN

Send To: SYNAGRO MID-ATLANTIC INC ARLINGTON
STEVE MCMAHON
10647 TIDEWATER TR
CHAMPLAIN VA 22438

Date Sampled: 11/28/2004
Date Received: 12/01/2004
Date Reported: 12/07/2004

Sample ID: ARLINGTON NOV

BIOSOLIDS ANALYSIS REPORT

Parameter	Result (%)	Result (mg/kg)	Detection Limit (mg/kg)	Analyst	Analysis Date	Analysis Time	Method Reference
SOLIDS(AS IS)	31.95	319500	100	JCM	12/01/2004	16:00	SM 2540 G
NITROGEN(TKN)	3.72	37200	100	KCS	12/02/2004	15:00	EPA 351.3
PHOSPHORUS	1.43	14300	100	JCM	12/02/2004	15:00	SW 846-6010B
POTASSIUM	0.20	2000	100	JCM	12/02/2004	15:00	SW 846-6010B
SULFUR	0.42	4200	100	JCM	12/02/2004	15:00	SW 846-6010B
CALCIUM	10.30	103000	100	JCM	12/02/2004	15:00	SW 846-6010B
MAGNESIUM	0.25	2500	100	JCM	12/02/2004	15:00	SW 846-6010B
SODIUM	0.01	100	100	JCM	12/02/2004	15:00	SW 846-6010B
IRON		34900	1	JCM	12/02/2004	15:00	SW 846-6010B
MANGANESE		244	1	JCM	12/02/2004	15:00	SW 846-6010B
COPPER		139	1	JCM	12/02/2004	15:00	SW 846-6010B
ZINC		281	1	JCM	12/02/2004	15:00	SW 846-6010B
AMMONIA-NITROGEN	0.10	1000	100	KCS	12/02/2004	14:00	EPA 350.2
NO3-NO2 NITROGEN		ND	10	KCS	12/02/2004	15:00	SM 4500-NO3 F
CADMIUM		2.0	1	JCM	12/02/2004	15:00	SW 846-6010B
CHROMIUM		35	5	JCM	12/02/2004	15:00	SW 846-6010B
NICKEL		14	5	JCM	12/02/2004	15:00	SW 846-6010B
LEAD		42	5	JCM	12/02/2004	15:00	SW 846-6010B

ALL VALUES ARE ON A DRY WEIGHT BASIS EXCEPT AS NOTED.

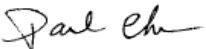
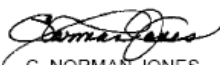
PAUL C. H. CHU

C. NORMAN JONES

Our reports and letters are for the exclusive and confidential use of our clients, and may not be reproduced in whole or in part, nor may any reference be made to the work, the results, or the company in any advertising, news release, or other public announcements without obtaining our prior written authorization.

Report Number:
2004-R339-033

A&L EASTERN AGRICULTURAL LABORATORIES, INC.

7621 Whitepine Road • Richmond, Virginia 23237 • (804) 743-9401
Fax No. (804) 271-6446



Lab Number:
44116 Page 2

Account Number:
74660

Samples Submitted By:
BRYAN CAUTHORN

Send To: SYNAGRO MID-ATLANTIC INC ARLINGTON
STEVE MCMAHON
10647 TIDEWATER TR
CHAMPLAIN VA 22438

Date Sampled: 11/28/2004
Date Received: 12/01/2004
Date Reported: 12/07/2004

Sample ID: ARLINGTON NOV

BIOSOLIDS ANALYSIS REPORT

Parameter	Result (%)	Result (mg/kg)	Detection Limit (mg/kg)	Analyst	Analysis Date	Analysis Time	Method Reference
ARSENIC		1.43	0.2	KMM	12/06/2004	15:00	SW 846-7061A
MERCURY		1.01	0.2	KMM	12/06/2004	15:00	SW 846-7471A
SELENIUM		2.77	0.1	KMM	12/06/2004	15:00	SW 846-7741A
PH (STD.UNITS;AS IS)	12.40			RD	12/02/2004	12:30	EPA 150.1
CALCIUM CARBONATE EQV	19.54	195400	100	KCS	12/06/2004	14:00	A0AC 955.01
VOLATILE SOLIDS	64.88	648800	100	KCS	12/02/2004	16:00	SM 2540G
ORGANIC NITROGEN	3.62	36200	100	DCH	12/02/2004	.	CALCULATION
MOLYBDENUM		22	5	JCM	12/02/2004	15:00	SW 846-6010B

ALL VALUES ARE ON A DRY WEIGHT BASIS EXCEPT AS NOTED.

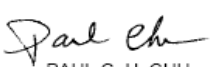
PAUL C. H. CHU

C. NORMAN JONES

Our reports and letters are for the exclusive and confidential use of our clients, and may not be reproduced in whole or in part, nor may any reference be made to the work, the results, or the company in any advertising, news release, or other public announcements without obtaining our prior written authorization.

Appendix D
Initial Soil Sampling (Fall 2004)

Table D-1. Soil chemical analysis of experiment blocks one and two. Samples were taken over September 2004. Acid extractable nutrient and metal values in mg/kg.

ILUKA RESEARCH FARM (IRF)											
Samples collected on 9/23/04											
Zenah Orndorff											
block	point	pH	P	K	Ca	Mg	Zn	Mn	Cu	Fe	B
101	1	6.79	18	83	632	112	0.8	5.6	1.1	22.8	0.2
101	2	7.28	37	133	1060	178	1.5	10.2	2.4	37.4	0.3
101	3	7.71	20	46	591	110	0.5	3.0	0.5	12.7	0.1
101	4	7.23	26	52	704	135	0.4	2.5	3.0	7.3	0.2
101	5	7.49	53	67	527	103	0.6	5.0	0.3	7.1	0.1
	avg	7.30	31	76	703	128	0.8	5.3	1.5	17.5	0.2
102	1	6.51	9	102	700	121	0.7	6.7	1.0	35.5	0.2
102	2	6.99	15	60	511	98	0.6	7.4	0.7	28.9	0.2
102	3	6.45	98	84	634	109	1.1	4.8	0.6	31.2	0.2
102	4	7.12	17	62	507	103	0.6	2.6	1.0	12.4	0.2
102	5	6.80	6	61	482	97	0.4	2.0	0.4	5.5	0.2
	avg	6.77	29	74	567	106	0.7	4.7	0.7	22.7	0.2
103	1	7.30	7	47	653	124	0.7	4.7	1.0	18.8	0.2
103	2	7.39	10	62	688	137	0.7	6.0	1.0	21.9	0.2
103	3	7.24	31	94	538	118	0.6	3.7	0.2	12.2	0.2
103	4	8.04	24	110	1011	171	0.6	3.2	0.9	14.6	0.2
103	5	6.69	17	93	222	58	0.4	2.4	0.4	15.3	0.1
	avg	7.33	18	81	622	122	0.6	4.0	0.7	16.6	0.2
104	1	7.49	9	41	498	91	0.4	4.1	0.4	17.4	0.2
104	2	6.80	20	96	609	129	0.8	6.2	1.0	26.9	0.2
104	3	6.63	17	58	594	112	0.5	2.5	0.6	12.4	0.2
104	4	7.27	16	92	613	112	0.5	2.8	0.5	14.0	0.2
104	5	7.05	9	66	436	94	0.4	2.4	0.4	7.9	0.2
	avg	7.05	14	71	550	108	0.5	3.6	0.6	15.7	0.2
201	1	7.18	15	68	480	94	0.5	3.8	0.4	16.7	0.2
201	2	7.42	14	61	592	115	0.6	5.7	0.8	18.1	0.2
201	3	6.06	21	97	448	99	0.7	5.4	0.8	18.2	0.2
201	4	7.27	11	67	565	113	0.4	3.0	0.6	11.1	0.2
201	5	7.78	7	58	992	166	0.7	3.2	1.1	16.9	0.2
	avg	7.14	14	70	615	117	0.6	4.2	0.7	16.2	0.2
202	1	6.19	7	52	354	72	0.6	3.6	0.7	15.3	0.2
202	2	6.29	7	66	432	98	0.5	6.5	0.9	22.5	0.2
202	3	7.14	11	82	495	97	0.4	3.7	0.4	12.5	0.2
202	4	7.75	10	79	718	142	0.4	3.4	0.3	9.9	0.2
202	5	7.77	13	70	861	168	0.5	3.2	0.3	13.7	0.2
	avg	7.03	10	70	572	115	0.5	4.1	0.5	14.8	0.2

Table D-1 Cont'd. Soil chemical analysis of experiment blocks one and two. Samples were taken over September 2004. Acid extractable nutrient and metal values in mg/kg.

ILUKA RESEARCH FARM (IRF)											
Samples collected on 9/23/04											
Zenah Orndorff											
block	point	pH	P	K	Ca	Mg	Zn	Mn	Cu	Fe	B
203	1	7.02	11	46	721	120	0.9	7.1	1.6	25.5	0.2
203	2	5.87	20	85	348	76	0.5	5.6	0.3	15.2	0.1
203	3	5.57	4	60	351	76	0.5	3.6	1.0	8.5	0.2
203	4	7.11	24	79	481	107	0.4	2.5	0.4	7.0	0.2
203	5	7.65	15	80	481	92	0.4	2.5	0.5	21.7	0.1
	avg	6.64	15	70	476	94	0.5	4.3	0.8	15.6	0.2
204	1	6.52	13	83	465	98	0.5	3.9	0.6	16.0	0.2
204	2	6.19	5	62	474	100	0.4	3.8	0.5	14.9	0.2
204	3	7.26	18	92	563	122	0.5	3.8	0.6	19.2	0.2
204	4	7.67	10	59	907	142	0.3	2.2	0.2	7.1	0.2
204	5	7.59	9	61	531	97	0.4	2.6	0.3	13.9	0.2
	avg	7.05	11	71	588	112	0.4	3.3	0.4	14.2	0.2
301	1	7.23	25	98	574	109	0.7	5.2	0.7	23.2	0.2
301	2	7.30	5	62	808	143	0.5	3.2	0.9	11.7	0.2
301	3	7.28	9	72	784	143	0.6	3.5	1.1	13.1	0.2
301	4	7.45	9	95	565	107	0.6	3.8	0.7	14.8	0.2
301	5	7.12	10	58	440	88	0.3	2.1	0.3	10.8	0.1
	avg	7.28	11.6	77	634	118	0.5	3.6	0.7	14.7	0.2
302	1	6.58	17	108	457	100	0.5	3.8	0.3	16.2	0.2
302	2	7.11	5	95	450	96	0.5	2.5	0.9	10.1	0.2
302	3	6.28	5	60	338	78	0.3	1.9	0.3	5.2	0.1
302	4	7.94	14	60	635	112	0.4	2.6	0.7	8.6	0.1
302	5	7.17	28	83	679	138	0.6	1.6	0.8	6.7	0.2
	avg	7.02	13.8	81.2	512	105	0.5	2.5	0.6	9.4	0.2
303	1	6.72	39	120	584	127	1.0	6.5	1.3	33.5	0.2
303	2	6.93	9	67	559	109	0.6	3.5	1.0	13.1	0.2
303	3	7.54	29	95	550	100	0.4	2.2	0.4	10.6	0.2
303	4	7.89	23	79	687	134	0.5	2.5	0.6	11.3	0.2
303	5	6.11	5	84	524	132	0.5	3.0	0.7	6.4	0.2
	avg	7.04	21	89	581	120	0.6	3.5	0.8	15.0	0.2
304	1	6.52	12	94	761	124	0.7	8.2	0.8	19.0	0.2
304	2	6.68	11	56	609	113	0.4	2.5	0.4	8.2	0.1
304	3	7.19	9	72	917	178	0.6	4.2	0.8	11.6	0.2
304	4	7.93	32	104	991	170	0.5	1.9	0.4	8.4	0.2
304	5	6.38	16	79	602	149	0.5	7.2	0.8	10.6	0.2
	avg	6.94	16	81	776	147	0.5	4.8	0.6	11.6	0.2

Table D-1 Cont'd. Soil chemical analysis of experiment blocks one and two. Samples were taken over September 2004. Acid extractable nutrient and metal values in mg/kg.

ILUKA RESEARCH FARM (IRF)											
Samples collected on 9/23/04											
Zenah Orndorff											
block	point	pH	P	K	Ca	Mg	Zn	Mn	Cu	Fe	B
301	1	7.23	25	98	574	109	0.7	5.2	0.7	23.2	0.2
301	2	7.30	5	62	808	143	0.5	3.2	0.9	11.7	0.2
301	3	7.28	9	72	784	143	0.6	3.5	1.1	13.1	0.2
301	4	7.45	9	95	565	107	0.6	3.8	0.7	14.8	0.2
301	5	7.12	10	58	440	88	0.3	2.1	0.3	10.8	0.1
avg		7.28	11.6	77	634	118	0.5	3.6	0.7	14.7	0.2
302	1	6.58	17	108	457	100	0.5	3.8	0.3	16.2	0.2
302	2	7.11	5	95	450	96	0.5	2.5	0.9	10.1	0.2
302	3	6.28	5	60	338	78	0.3	1.9	0.3	5.2	0.1
302	4	7.94	14	60	635	112	0.4	2.6	0.7	8.6	0.1
302	5	7.17	28	83	679	138	0.6	1.6	0.8	6.7	0.2
avg		7.02	13.8	81.2	512	105	0.5	2.5	0.6	9.4	0.2
303	1	6.72	39	120	584	127	1.0	6.5	1.3	33.5	0.2
303	2	6.93	9	67	559	109	0.6	3.5	1.0	13.1	0.2
303	3	7.54	29	95	550	100	0.4	2.2	0.4	10.6	0.2
303	4	7.89	23	79	687	134	0.5	2.5	0.6	11.3	0.2
303	5	6.11	5	84	524	132	0.5	3.0	0.7	6.4	0.2
avg		7.04	21	89	581	120	0.6	3.5	0.8	15.0	0.2
304	1	6.52	12	94	761	124	0.7	8.2	0.8	19.0	0.2
304	2	6.68	11	56	609	113	0.4	2.5	0.4	8.2	0.1
304	3	7.19	9	72	917	178	0.6	4.2	0.8	11.6	0.2
304	4	7.93	32	104	991	170	0.5	1.9	0.4	8.4	0.2
304	5	6.38	16	79	602	149	0.5	7.2	0.8	10.6	0.2
avg		6.94	16	81	776	147	0.5	4.8	0.6	11.6	0.2
401	1	6.78	13	58	554	104	0.5	3.9	0.5	10.3	0.2
401	2	7.34	14	39	233	43	0.3	0.9	0.2	15.2	0.1
401	3	5.90	2	26	285	68	0.4	2.3	0.5	7.2	0.1
401	4	7.35	8	62	715	136	0.8	6.6	1.7	19.8	0.2
401	5	4.88	2	12	85	21	0.3	1.3	0.3	3.2	0.1
avg		6.45	7.8	39.4	374	74	0.5	3.0	0.6	11.1	0.1
402	1	6.38	5	109	717	139	0.6	5.0	1.1	11.9	0.2
402	2	7.82	15	35	477	71	0.4	2.6	0.3	9.5	0.1
402	3	7.70	15	43	288	55	0.4	2.1	0.3	18.8	0.1
402	4	7.44	11	69	701	125	0.6	4.1	0.9	13.9	0.2
402	5	7.67	6	73	536	104	0.4	4.6	0.5	21.7	0.2
avg		7.40	10.4	65.8	544	99	0.5	3.7	0.6	15.2	0.2

Table D-1 Cont'd. Soil chemical analysis of experiment blocks one and two. Samples were taken over September 2004. Acid extractable nutrient and metal values in mg/kg.

ILUKA RESEARCH FARM (IRF)											
Samples collected on 9/23/04											
Zenah Orndorff											
block	point	pH	P	K	Ca	Mg	Zn	Mn	Cu	Fe	B
403	1	5.10	2	39	311	83	0.8	10.4	1.9	10.5	0.2
403	2	7.78	72	100	1020	176	0.8	4.3	0.6	9.2	0.2
403	3	7.93	16	69	782	133	0.4	2.6	0.4	8.3	0.1
403	4	7.12	13	51	616	101	0.4	3.1	0.3	12.0	0.1
403	5	7.31	7	78	716	129	0.7	5.4	0.7	39.3	0.3
avg		7.05	22	67.4	689	124	0.6	5.2	0.8	15.9	0.2
404	1	4.96	2	34	237	60	0.4	9.3	0.4	9.2	0.2
404	2	7.53	3	35	405	81	0.3	2.9	0.3	8.4	0.2
404	3	7.93	20	74	1343	208	0.6	4.5	0.6	11.0	0.2
404	4	7.49	25	70	875	142	0.5	3.2	0.6	9.4	0.2
404	5	8.00	15	77	1297	209	0.5	3.3	0.7	10.2	0.2
avg		7.18	13	58	831	140	0.5	4.6	0.5	9.6	0.2

Appendix E
Auger Soil Sample Data (Summer 2005)

Table E-1 – Percent clay, percent sand and textural classes at 0 to 15-cm for the CWRP (Summer 2005).

Plot ID	Treatment	Depth (cm)	% Clay	% Total Sand	% Silt	Textural Class
101-1	Bio-NT	0-15	20	69	11	SCL/SL
101-2	Bio-NT	0-15	11	81	7	LS
101-3	Bio-NT	0-15	26	68	6	SCL
101-4	Bio-NT	0-12	22	71	7	SCL
101-5	Bio-NT	0-15	29	62	9	SCL
102-1	Bio-CT	0-15	18	75	7	SL
102-2	Bio-CT	0-15	19	71	11	SL
102-3	Bio-CT	0-15	21	66	14	SCL
102-4	Bio-CT	0-15	19	75	6	SL
102-5	Bio-CT	0-15	23	68	9	SCL
103-1	Control	0-15	15	75	10	SL
103-2	Control	0-15	14	79	7	SL
103-3	Control	0-15	20	70	10	SCL/SL
103-4	Control	0-15	17	78	6	SL
103-5	Control	0-15	15	80	5	SL
104-1	Topsoil	0-15	12	68	20	SL
104-2	Topsoil	0-15	16	74	10	SL
104-3	Topsoil	0-15	19	64	17	SL
104-4	Topsoil	0-15	17	59	24	SL
104-5	Topsoil	0-15	18	64	18	SL
201-1	Topsoil	0-15	14	63	23	SL
201-2	Topsoil	0-15	15	65	21	SL
201-3	Topsoil	0-15	15	63	22	SL
201-4	Topsoil	0-15	14	64	22	SL
201-5	Topsoil	0-15	16	66	18	SL
202-1	Bio-NT	0-15	17	70	14	SL
202-2	Bio-NT	0-15	18	69	13	SL
202-3	Bio-NT	0-15	23	66	11	SCL
202-4	Bio-NT	0-15	22	69	9	SCL
202-5	Bio-NT	0-15	21	72	7	SCL
203-1	Control	0-15	16	74	10	SL
203-2	Control	0-15	23	66	11	SCL
203-3	Control	0-15	20	71	10	SCL/SL
203-4	Control	0-15	21	69	10	SCL
203-5	Control	0-15	15	78	7	SL
204-1	Bio-CT	0-15	22	67	12	SCL
204-2	Bio-CT	0-15	21	65	14	SCL
204-3	Bio-CT	0-15	20	70	10	SCL/SL
204-4	Bio-CT	0-15	27	64	9	SCL
204-5	Bio-CT	0-15	21	70	9	SCL

Table E-1 Cont'd – Percent clay, percent sand and textural classes at 0 to 15-cm for the CWRP (Summer 2005).

Plot ID	Treatment	Depth (cm)	% Clay	% Total Sand	% Silt	Textural Class
301-1	Bio-NT	0-15	20	69	11	SCL/SL
301-2	Bio-NT	0-15	24	67	10	SCL
301-3	Bio-NT	0-15	25	66	9	SCL
301-4	Bio-NT	0-15	18	73	9	SL
301-5	Bio-NT	0-15	15	77	8	SL
302-1	Bio-CT	0-15	18	70	12	SL
302-2	Bio-CT	0-15	21	70	9	SCL
302-3	Bio-CT	0-15	27	64	9	SCL
302-4	Bio-CT	0-15	14	77	9	SL
302-5	Bio-CT	0-15	20	70	10	SCL/SL
303-1	Topsoil	0-15	14	65	21	SL
303-2	Topsoil	0-15	16	62	22	SL
303-3	Topsoil	0-15	15	63	23	SL
303-4	Topsoil	0-15	15	67	18	SL
303-5	Topsoil	0-15	12	62	26	SL
304-1	Control	0-15	25	65	10	SCL
304-2	Control	0-15	24	66	11	SCL
304-3	Control	0-15	31	59	10	SCL
304-4	Control	0-15	18	76	6	SL
304-5	Control	0-15	29	62	9	SCL
401-1	Control	0-15	30	59	11	SCL
401-2	Control	0-15	6	93	2	S
401-3	Control	0-15	14	81	6	SL
401-4	Control	0-15	20	71	9	SCL/SL
401-5	Control	0-15	22	69	9	SCL
402-1	Topsoil	0-15	13	65	22	SL
402-2	Topsoil	0-15	15	68	17	SL
402-3	Topsoil	0-15	14	66	20	SL
402-4	Topsoil	0-15	13	72	15	SL
402-5	Topsoil	0-15	17	60	23	SL
403-1	Bio-CT	0-15	32	54	14	SCL
403-2	Bio-CT	0-15	21	71	9	SCL
403-3	Bio-CT	0-15	9	84	8	LS
403-4	Bio-CT	0-15	18	76	6	SL
403-5	Bio-CT	0-15	17	75	8	SL
404-1	Bio-NT	0-15	30	58	12	SCL
404-2	Bio-NT	0-15	17	75	7	SL
404-3	Bio-NT	0-15	19	73	8	SL
404-4	Bio-NT	0-15	15	76	9	SL
404-5	Bio-NT	0-15	16	79	6	SL

Table E-2 – Percent clay, percent sand and textural class at 0 to 15-cm for the Compacted Area (Summer 2005).

Plot ID	Treatment	Depth (cm)	% Clay	% Total Sand	% Silt	Textural Class
EC 1-1	Compacted Area	0-15	15	74	12	SL
EC 1-2	Compacted Area	0-15	13	79	8	SL
EC 2-1	Compacted Area	0-15	14	75	11	SL
EC 2-2	Compacted Area	0-15	14	74	12	SL
EC 3-1	Compacted Area	0-15	16	73	11	SL
EC 3-2	Compacted Area	0-15	18	69	14	SL
EC 4-1	Compacted Area	0-15	15	72	13	SL
EC 4-2	Compacted Area	0-15	12	76	13	SL
EC 5-1	Compacted Area	0-15	13	76	11	SL
EC 5-2	Compacted Area	0-15	15	75	10	SL
EC 6-1	Compacted Area	0-15	14	76	16	SL
EC 6-2	Compacted Area	0-15	18	71	11	SL
EC 7-1	Compacted Area	0-15	13	74	13	SL
EC 7-2	Compacted Area	0-15	19	68	12	SL
EC 8-1	Compacted Area	0-15	23	67	10	SCL
EC 8-2	Compacted Area	0-15	21	69	10	SCL
EC 9-1	Compacted Area	0-15	19	73	9	SL
EC 9-2	Compacted Area	0-15	22	70	8	SCL
EC 10-1	Compacted Area	0-15	19	71	9	SL
EC 10-2	Compacted Area	0-15	22	69	9	SCL
EC 11-1	Compacted Area	0-15	20	69	10	SCL/SL
EC 11-2	Compacted Area	0-15	20	69	11	SCL/SL
EC 12-1	Compacted Area	0-15	19	72	9	SL
EC 12-2	Compacted Area	0-15	16	74	10	SL

Table E-3 – Percent clay, percent sand and textural class at 0 to 15 cm for the Clarke Farm/offsite Control.

Plot ID	Treatment	Depth (cm)	% Clay	% Total Sand	% Silt	Textural Class
C1-1	Clarke Farm	0-15	7	75	18	SL
C1-2	Clarke Farm	0-15	10	73	18	SL
C1-3	Clarke Farm	0-15	6	74	20	SL
C1-4	Clarke Farm	0-15	11	74	15	SL
C1-5	Clarke Farm	0-15	9	71	21	SL
C2-1	Clarke Farm	0-15	8	74	18	SL
C2-2	Clarke Farm	0-15	9	72	20	SL
C2-3	Clarke Farm	0-15	9	74	17	SL
C2-4	Clarke Farm	0-15	5	74	21	SL/LS
C2-5	Clarke Farm	0-15	10	73	17	SL
C3-1	Clarke Farm	0-15	8	72	20	SL
C3-2	Clarke Farm	0-15	9	66	25	SL
C3-3	Clarke Farm	0-15	9	73	18	SL
C3-4	Clarke Farm	0-15	4	73	23	SL/LS
C3-5	Clarke Farm	0-15	9	75	16	SL
C4-1	Clarke Farm	0-15	9	64	27	SL
C4-2	Clarke Farm	0-15	10	63	27	SL
C4-3	Clarke Farm	0-15	6	75	18	SL
C4-4	Clarke Farm	0-15	10	74	16	SL
C4-5	Clarke Farm	0-15	8	72	20	SL

Appendix F
Auger Profile Descriptions for the Carraway-Winn
Reclamation Research Farm (Summer 2005)

Vegetation: Corn

Parent Material: Mineral sands mining tailings and slime derived from stratified Upper Coastal Plain fluviomarine sediments and soil

Physiography: Reconstructed ridge summit; Relief: 5m;

Elevation 65 m, Slope 2 %;

(All profiles were described and sampled between May and September of 2005)

Auger Boring: 101-1 (Biosolids-No Tillage); Date: 05/31/05; Sampled by: K. Meredith and Z. Orndorff

^Ap-- 0 – 29 cm; dark yellow brown (10YR 4/4) sandy loam/sandy clay loam with sandy clay loam bodies and coatings.

2^Ab-- 29 – 44 cm; dark gray (2.5Y 4/1) sandy loam with few sandy clay loam bodies.

3^C1-- 44 – 61 cm; brownish yellow (10YR 6/6) loamy sand.

3^C2-- 61 – 78 cm; yellowish red (5YR 4/6) clay to silty clay.

3^C3-- 78 – 130+ cm; yellowish (2.5Y 7/6) sand.

Notes:

- 2^Ab horizon: Large dead roots evident throughout horizon.
- 3^C2 horizon: Softer, siltier clay evident within lower 15 cm of horizon.

Auger boring: 101-2 (Biosolids-No Tillage); Date: 05/31/05; Sampled by: K. Meredith and Z. Orndorff

^Ap-- 0 – 17 cm; dark yellow brown (10YR 4/6) loamy sand with sandy clay loam bodies with common, medium to coarse, prominent, brown mottles (7.5YR 4/2).

^C1-- 17 – 35 cm; reddish brown (7.5YR 6/8) sand; loose.

^C2-- 35 – 62 cm; yellowish red (5YR 4/6) clay.

^C3-- 62 – 130+ cm; brownish yellow (10YR 6/6) sand.

Notes:

- ^C1 horizon: Dry horizon.
- ^C2 horizon: Dense clay, uniform in texture and color.
- ^C3 horizon: Sand is tighter, denser, than C1 horizon.

Auger boring: 101-3 (Biosolids-No Tillage); Date: 05/31/05; Sampled by: K. Meredith and Z. Orndorff

^Ap-- 0 – 13 cm; yellowish red (5YR 5/6) sandy clay loam with few clay bodies.

^C1-- 13 – 62 cm; yellowish red (5YR 4/6) clay.

^C2-- 62 – 100 cm; brownish yellow (10YR 6/8) sand.

^C3-- 100 – 130+ cm; pale yellow (2.5Y 7/4) sand.

Notes:

- ^C1 horizon: Dense clay with an abrupt boundary to sandy layer below. Little color variation, clay becomes softer, siltier with depth.
- ^C2 horizon: Sand is coarser than profiles 101-5 and 101-4.
- ^C3 horizon: Sand is coarser than profiles 101-5 and 101-4.

Auger boring: 101-4 (Biosolids-No Tillage); Date: 05/31/05; Sampled by: K. Meredith and Z. Orndorff

- ^Ap-- 0 – 12 cm; yellowish red (5YR 5/6) sandy clay loam with few clay bodies.
- ^C1-- 12 – 76 cm; yellowish red (5YR 4/6) clay.
- ^C2-- 76 – 98 cm; pale yellow (2.5Y 7/4) sand.
- ^C3-- 98 – 120+ cm; brownish yellow (10YR 6/6) sand.

Notes:

- ^C1 horizon: Dense clay with an abrupt boundary to sandy layer below. Little color variation, clay becomes softer, siltier with depth.
- ^C2 horizon: Sand is tight, dense.

Auger boring: 101-5 (Biosolids-No Tillage); Date: 05/31/05; Sampled by: K. Meredith and Z. Orndorff

- ^Ap-- 0 – 28 cm; yellowish red (5YR 4/6) sandy clay loam.
- ^C1-- 28 – 52 cm; yellowish red (5YR 4/6) clay loam to clay with sandy coatings.
- ^C2-- 52 – 72 cm; brownish yellow (10YR 6/6) sand with common, medium to coarse, distinct, olive yellow (2.5Y 6/6) fragments of an A horizon.
- ^C3-- 72 – 130+ cm; brownish yellow (10YR 6/8) sand.

Notes:

- ^Ap horizon: Red color most likely a result of red clay coatings.
- ^C1 horizon: Sandy coatings more evident towards bottom 5 cm of horizon.
- ^C2 horizon: Few clay loam bodies prominent.
- ^C3 horizon: Slight variation in color than ^C2 horizon.

Auger boring: 102-1 (Biosolids-Conventional Tillage); Date: 06/01/05; Sampled by: K. Meredith and Z. Orndorff

- ^Ap-- 0 – 36 cm; brown (7.5YR 4/4) sandy loam.
- ^Ab-- 36 – 58 cm; dark grayish brown (2.5Y 4/2) sandy loam to sandy clay loam.
- 2^C1-- 58 – 71 cm; reddish yellow (7.5YR 6/8) sand.
- 2^C2-- 71 – 92 cm; yellowish red (5YR 4/6) clay.
- 2^C3-- 92 – 130+ cm; brownish yellow (10YR 6/6) sand.

Notes:

- ^Ap horizon: Small, patchy, thin bands of very dark grayish brown (10YR 3/2) material surrounding dead roots.

- 2^C2 horizon: Uniform in overall texture. Hard, dense, clay with few films and channels of light yellowish brown (10YR 6/4) material surrounding roots-possibly redoximorphic features.
- 2^C3 horizon: Color is variegated, mixed.

Auger boring: 102-2 (Biosolids-Conventional Tillage); Date: 06/01/05; Sampled by: K. Meredith and Z. Orndorff

- ^Ap-- 0 – 15 cm; dark yellow brown (10YR 4/6) sandy loam with common, coarse, prominent, yellowish red (5YR 4/6), and common, medium to coarse, prominent, dark grayish brown (2.5Y 4/2) bodies.
- ^Cd-- 15 – 38 cm; dark gray brown (2.5Y 4/2) sandy clay loam.
- ^C1-- 38 – 68 cm; brownish yellow (10YR 6/8) coarse sand.
- ^C2-- 68 – 80 cm; strong brown (7.5YR 5/8) clay to silty clay.
- ^C3-- 80 – 130+ cm; brownish yellow (10YR 6/8) grades to yellow (10YR 7/8) sand.

Notes:

- ^Cd horizon: Dense layer with many decayed roots.
- ^C1 horizon: Sand is loose, uniform in color.
- ^C2 horizon: Clay is dense, but softer than hard, brittle, red clay. Uniform in overall color and texture.
- ^C3 horizon: Sand is very tight, dense. Uniform in overall color and texture.

Auger boring: 102-3 (Biosolids-Conventional Tillage); Date: 06/01/05; Sampled by: K. Meredith and Z. Orndorff

- ^Ap1-- 0 – 15 cm; dark grayish brown (2.5Y 4/2) sandy clay loam.
- ^Ap2-- 15 – 30 cm; dark grayish brown (2.5Y 4/3) sandy clay loam.
- ^C1-- 30 – 51 cm; brownish yellow (10YR 6/8) sand; loose.
- ^C2-- 51 – 70 cm; strong brown (7.5YR 5/8) clay to silty clay.
- ^C3-- 70 – 130+ cm; yellow (10YR 7/6) grades to yellow (2.5Y 7/6) sand.

Notes:

- ^Ap1 horizon: Within upper 3 to 5 cm of horizon, dark bodies with olive brown (2.5Y 4/4) coatings evident. There is no clear boundary evident between colors. Layer is compacted with decayed roots.
- ^C1 horizon: Sand is uniform in color and overall coarseness.
- ^C2 horizon: Clay is dense, but softer, siltier than hard, brittle red clay. Uniform in overall texture and color.
- ^C3 horizon: Sand is tight, dense.

Auger boring: 102-4 (Biosolids-Conventional Tillage); Date: 06/01/05; Sampled by: K. Meredith and Z. Orndorff

- ^Ap-- 0 – 20 cm; reddish yellow (7.5YR 5/6) sandy loam with few, medium to coarse, prominent, very dark grayish brown (10YR 3/2) bodies.

- ^C1-- 20 – 56 cm; strong brown (7.5YR 5/6) sandy clay loam.
- ^C2-- 56 – 76 cm; strong brown (7.5YR 5/8) clay to silty clay.
- ^Cd-- 76 – 130 cm; pale yellow (2.5Y 7/4) coarse sand.

Notes:

- ^Ap horizon: Horizon is as a mixture of red clay bodies and dark brown bodies with sandy coatings. Dark brown bodies are most likely a result of the biosolid treatment.
- ^C1 horizon: Clay bodies with sandy coatings.
- ^C2 horizon: Uniform color and texture. Layer is dense; however, clay is soft, silty and not brittle.
- ^Cd horizon: Sand is tight, dense. Uniform in color and overall texture of horizon.

Auger boring: 102-5 (Biosolids-Conventional Tillage); Date: 06/01/05; Sampled by: K. Meredith and Z. Orndorff

- ^Ap-- 0 – 23 cm; reddish yellow (7.5YR 6/8) sandy clay loam with common, coarse to very coarse, faint, strong brown (7.5YR 5/8) bodies.
- ^AC-- 23 – 49 cm; reddish yellow (7.5YR 5/8) sandy clay loam with common, coarse to very coarse, faint, strong brown (7.5YR 5/8) fragments of a Bt horizon.
- 2^C1-- 49 – 66 cm; strong brown (7.5YR 5/8) clay to silty clay.
- 2^C2-- 66 – 130+ cm; pale yellow (2.5Y 7/4) coarse sand.

Notes:

- ^Ap horizon: Bodies are coated in sand. Horizon is sandier than ^AC horizon.
- 2^C1 horizon: Uniform in overall color and texture. Clay is dense, but is soft, silty and smooth.
- 2^C2 horizon: Sand is tight, dense. Layer is uniform in overall color and texture.

Auger boring: 103-1 (Control); Date: 06/01/05; Sampled by: K. Meredith and Z. Orndorff

- ^Ap-- 0 – 23 cm; brown (7.5YR 4/4) sandy loam; loose.
- ^C1-- 23 – 31 cm; grayish brown (10YR 5/2) sandy loam with common, medium to coarse, distinct, yellow brown (10YR 5/6) sandy coatings.
- 2^C2-- 31 – 45 cm; dark red (2.5YR 4/6) clay with common, coarse to very coarse, prominent, yellow brown (10YR 5/6) fragments of an A horizon.
- 3^Ab1-- 45 – 71 cm; gray brown (10YR 5/2) sandy clay loam with common, coarse, prominent, red (2.5YR 4/8) clay slime fragments.
- 3^Ab2-- 71 – 87 cm; dark gray brown (10YR 4/2) sandy loam to sandy clay loam.
- 4^C3-- 87 – 130+ cm; brownish yellow (10YR 6/6) sand.

Notes:

- ^C1 horizon: Horizon is a mixture of gray brown clay bodies with yellow brown sandy coatings.
- 2^C2 horizon: Horizon is a mixture of clay bodies with sandy coatings. Dense layer.
- 3^Ab1 horizon: Dense material. A strong septic smell apparent--most likely a result of biosolids treatment.
- 3^Ab2 horizon: Organic matter prominent throughout layer.

- 4^C3 horizon: Some organic material evident within upper 3 to 5 cm of horizon--may have leached from Ab2 horizon.

Auger boring: 103-2 (Control); Date: 06/01/05; Sampled by: K. Meredith and Z. Orndorff

- ^Ap-- 0 – 13 cm; dark yellow brown (10YR 4/6) sandy loam.
- 2^C1-- 13 – 26 cm; yellow red (5YR 5/8) clay bodies with sandy coatings and common, medium, prominent, dark gray brown (2.5Y 4/2) bodies.
- 3^C2-- 26 – 40 cm; brownish yellow (10YR 6/6) sand with few to common, extremely coarse, prominent, dark gray brown (2.5Y 4/2) sandy clay loam bodies.
- 4^Ab-- 40 – 44 cm; dark gray (2.5Y 4/1) sandy clay loam.
- 4^Bw-- 44 – 56 cm; yellow brown (10YR 5/6) sandy clay loam with many, coarse to very coarse, prominent, dark gray (2.5Y 4/1) coatings and fragments of an A horizon.
- 4^Ab'-- 56 – 64 cm; dark gray (2.5Y 4/1) sandy clay loam.
- 5^C3-- 64 – 80 cm; yellow red (5YR 5/6) clay.
- 5^C4-- 80 – 130+ cm; brown yellow (10YR 6/6) sand.

Notes:

- ^Ap horizon: Few mixed sandy coated clay bodies prominent throughout layer.
- 2^C1 horizon: Layer is mostly red and dark yellowish brown (10YR 4/6) clay bodies with sandy coatings.
- 3^C2 horizon: Layer is mostly sand textured with few gray sandy clay loam bodies.
- 4^Ab horizon: Thick coarse (1.5 cm) decaying roots prominent within upper 5 cm.
- 5^C3 horizon: Dense, hard layer. Uniform in overall color and texture.

Auger boring: 103-3 (Control); Date: 06/01/05; Sampled by: K. Meredith and Z. Orndorff

- ^Ap-- 0 – 20 cm; red (2.5YR 4/8) sandy loam/sandy clay loam.
- 2^C1-- 20 - 30 cm; gray brown (10YR 5/2) sandy clay loam with common, coarse, prominent, yellowish red (5YR 4/6) fragments of a Bt horizon.
- 3^C2-- 30 – 84 cm; brown yellow (10YR 6/6) grades to strong brown (7.5YR 5/6) coarse sand.
- 3^C3-- 84 – 117 cm; yellowish red (5YR 5/8) clay.
- 3^C4-- 117 – 130+ cm; brownish yellow (10YR 6/6) sand; very friable to loose.

Notes:

- ^Ap horizon: Very dense layer, possible traffic pan.
- 2^C1 horizon: Dense layer. Roots and woody organic matter (1 cm thick) evident within upper 10 cm of horizon.
- 3^C2 horizon: Uniform in overall texture. Few, small red (2.5YR 4/8) clay balls, prominent throughout layer.
- 3^C3 horizon: Texture is predominantly clay bodies with sandy coatings.
- 3^C4 horizon: Layer is loose.

Auger boring: 103-4 (Control); Date: 06/01/05; Sampled by: K. Meredith and Z. Orndorff

- ^Ap-- 0 – 30 cm; strong brown (7.5 YR 5/6) sandy loam with small clay bodies.

- ^AC-- 30 – 54 cm; strong brown (7.5YR 5/8) sandy loam with small clay bodies.
- 2^C1-- 54 – 100 cm; yellow red (5YR 5/6) clay to silty clay with common, coarse to very coarse, prominent, red (2.5YR 4/8) clay slime fragments.
- 2^C2-- 100 – 130 cm; pale yellow (2.5Y 7/4) sand to sandy loam.

Auger boring: 103-5 (Control); Date: 06/01/05; Sampled by: K. Meredith and Z. Orndorff

- ^Ap-- 0 – 21 cm; yellow brown (10YR 5/6) sandy loam with few, fine to medium, prominent gray (2.5YR 6/1) and few, fine to medium, prominent, red (2.5YR 4/8) bodies and mottles.
- 2^Cd-- 21 – 37 cm; yellow red (5YR 5/6) clay with sandy coatings.
- 2^C1-- 37 – 49 cm; brown yellow (10YR 6/6) clay to sandy clay loam.
- 2^C2-- 43 – 43 cm; yellow red (5YR 5/6) clay to sandy clay loam.
- 2^C3-- 49 – 67 cm; strong brown (7.5YR 5/8) clay.
- 2^C4-- 67 – 130 + cm; pale yellow (2.5Y 7/4) sand.

Notes:

- ^Cd horizon: Dense material.
- 2^C1 horizon: Thick black coatings of decayed “rooty” organic matter prominent. Dense material.
- 2^C4 horizon: Few small clay bodies prominent throughout layer.

Auger boring: 104-1 (Topsoil); Date: 06/05/05; Sampled by: K. Meredith and Z. Orndorff

- ^Ap-- 0 – 12 cm; olive brown (2.5Y 4/3) sandy loam.
- 2^C1-- 12 – 37cm; strong brown (7.5YR 5/6) sand with clay bodies.
- 2^C2-- 37 – 75 cm; yellow red (5YR 5/6) clay to sandy clay loam with common, coarse to very coarse, prominent, dark gray brown (2.5Y 4/2) fragments of an A horizon.
- 3^C3-- 75 – 102 cm; yellow red (5YR 5/8) grades to olive yellow (2.5Y 4/4) sand.
- 3^C4-- 102 – 116 cm; light yellow brown (2.5Y 6/3) silty clay loam.
- 3^C5-- 116 – 130+ cm; brown (7.5YR 5/4) silty clay loam.

Notes:

- 2^C1 horizon: Clay bodies appear olive brown (2.5Y 4/4) and olive brown (2.5Y 4/3).
- 2^C2 horizon: Layer is mixed, with browner colors located towards top and bottom of horizon with redder colors prominent between 48 and 58 cm.
- 3^C3 horizon: Mixed red, yellow and white sands.
- 3^C4 horizon: Color is variegated with soft, clayey material. Clay is “marbled” or a mixture between red and brown colors.

Auger boring: 104-2 (Topsoil); Date: 06/05/05; Sampled by: K. Meredith and Z. Orndorff

- ^Ap1-- 0 – 20 cm; dark yellow brown (10YR 4/6) sandy loam.
- ^Ap2-- 20 – 40 cm; strong brown (10YR 4/8) sandy loam.
- 2^C1-- 40 – 71 cm; brown yellow (10YR 6/6) loamy sand.
- 2^C2-- 40 – 55 cm; brown yellow (10YR 5/6) loamy sand.

- 2^C3-- 71 – 85 cm; red (2.5YR 4/8) clay.
- 2^C4-- 85 – 99 cm; yellowish red (5YR 5/6) clay.
- 2^C5-- 99 – 115 cm; yellow (2.5Y 7/6) coarse sand.
- 2^C6-- 115 – 130+ cm; yellow (10YR 7/6) coarse sand.

Notes:

- ^Ap2 horizon: Increase in clay with depth.
- 2^C1 horizon: Dark gray brown (10YR 4/2) clay bodies prominent throughout horizon.
- 2^C4 horizon: Softer, yellowish red (5YR 5/6) clay than ^C3 horizon.
- 2^C5 horizon: Sand is uniform in overall texture.

Auger boring: 104-3 (Topsoil); Date: 06/05/05; Sampled by: K. Meredith and Z. Orndorff

- ^Ap1-- 0 – 15 cm; olive brown (2.5Y 4/3) sandy loam.
- ^Ap2-- 15 – 26 cm; dark grayish brown (2.5Y 4/2) sandy loam.
- 2^C1-- 26 – 63 cm; strong brown (7.5YR 5/6) sand.
- 2^C2-- 63 – 74 cm; yellow red (5YR 5/6) clay.
- 2^C3-- 74 – 100 cm; brown yellow (10YR 6/6) sand.
- 2^C4-- 100 – 130+ cm; pale yellow (2.5Y 8/4) fine sand.

Notes:

- ^Ap1 horizon: A thin layer of strong brown (7.5YR 4/6) sandy clay loam occurs between 12 and 15 cm.
- 2^C1 horizon: Redder color more prominent at top of horizon with yellow colors more prominent towards bottom.
- 2^C4 horizon: Sand is finer than ^C3 horizon above.

Auger boring: 104-4 (Topsoil); Date: 06/05/05; Sampled by: K. Meredith and Z. Orndorff

- ^Ap-- 0 – 11 cm; dark gray brown (2.5YR 4/2) sandy loam with clay bodies.
- 2^C1-- 11 – 68 cm; yellowish red (5YR 4/6) sandy loam.
- 2^C2-- 68 – 85 cm; yellowish red (5YR 4/6) clay.
- 2^C3-- 85 – 130+ cm; pale yellow (2.5YR 7/4) sand.

Notes:

- ^Ap horizon: Dense layer.
- 2^C1 horizon: Dense layer, uniform in overall color and texture.
- 2^C2 horizon: Very dense layer--denser than Ap and C1 horizons.
- 2^C3 horizon: Few, small, red, clay bodies and bodies prominent throughout horizon.

Auger boring: 104-5 (Topsoil); Date: 06/05/05; Sampled by: K. Meredith and Z. Orndorff

- ^Ap-- 0 – 16 cm; dark gray brown (2.5Y 4/2) sandy loam with common, medium, faint, olive brown (2.5Y 4/3) mottles.
- 2^C1-- 16 – 26 cm; strong brown (7.5YR 5/6) grades to yellowish red (5YR 5/6) clay bodies with sandy coatings.

- 2^C2-- 26 – 76 cm; yellow red (5YR 4/6) clay to silty clay with common, coarse to very coarse, prominent, brownish yellow (10YR 6/6) clay bodies.
- 2^C3-- 76 – 130+ cm; pale yellow (2.5Y 7/4) sand.

Auger boring: 201-1 (Topsoil); Date: 06/05/05; Sampled by: K. Meredith and Z. Orndorff

- ^Ap-- 0 – 16 cm; grayish brown (10YR 5/2) sandy loam.
- ^C1-- 16 – 56 cm; yellowish red (5YR 5/6) sandy loam with common, very coarse, prominent, dark gray brown (10YR 4/2) and common, very coarse, faint, yellowish red (5YR 5/6) clay bodies.
- ^C2-- 56 – 76 cm; brownish yellow (10YR 6/6) loamy sand with common, coarse to very coarse, distinct, yellowish red (5YR 5/6) clay bodies.
- ^C3-- 76 – 100 cm; strong brown (7.5YR 5/8) sandy loam with common, very coarse, prominent, dark gray brown (10YR 4/2) clay bodies.
- ^C4-- 100 – 130+ cm; yellow (2.5Y 7/6) coarse sand.

Notes:

- ^C4 horizon: Uniform in overall color and texture.

Auger boring: 201-2 (Topsoil); Date: 06/05/05; Sampled by: K. Meredith and Z. Orndorff

- ^Ap-- 0 – 14 cm; dark olive brown (2.5Y 3/3) sandy loam.
- 2^C1-- 14 – 56 cm; yellow red (5YR 5/6) clay to sandy clay loam with common, very coarse, prominent, dark grayish brown (2.5Y 4/2) bodies.
- 2^C2-- 56 – 130+ cm; reddish yellow (7.5YR 7/8) sand.
- 2^C3-- 61 – 130+ cm; reddish yellow (7.5YR 6/8) coarse sand.

Notes:

- 2^C1 horizon: Materials appear mixed, with red clay and gray sandy coated clay loam to loam bodies. Sizeable amounts of decayed dark yellowish brown (10YR 4/6) woody organic material evident throughout horizon.
- 2^C3 horizon: Sand becomes coarser with depth.

Auger boring: 201-3 (Topsoil); Date: 06/05/05; Sampled by: K. Meredith and Z. Orndorff

- ^Ap -- 0 – 15 cm; olive brown (2.5Y 4/3) sandy loam; loose.
- 2^C1-- 15 – 25 cm; yellowish red (5YR 4/6) sandy clay loam with common to many, coarse to very coarse, prominent, dark gray brown (10YR 4/2) fragments of an A horizon.
- 2^C2-- 25 – 51 cm; yellowish red (5YR 5/6) sandy clay loam with common to many, coarse to very coarse, prominent, dark gray brown (10YR 4/2) fragments of an A horizon.
- 3^C3-- 51 – 98 cm; reddish yellow (7.5YR 6/6) sand with clay to silty clay bodies.
- 3^C4-- 98 – 130 cm; yellow (10YR 7/6) sand.

Notes:

- ^Ap horizon: Uniform in overall texture and color.

- 2^C1 horizon: Black, decaying woody organic matter evident throughout layer. Soil is as a mixture of grays and red. Extremely dense layer--possible traffic pan.
- 2^C2 horizons: Black, decaying woody organic matter evident throughout layer. Soil is as a mixture of grays and red.
- 3^C3 horizon: Some, soft, smooth strong brown (7.5YR 5/8) clay bodies mixed with harder, dense red (5YR 4/6) clay bodies.
- 3^C4 horizon: Damp layer--however, not saturated.

Auger boring: 201-4 (Topsoil); Date: 06/05/05; Sampled by: K. Meredith and Z. Orndorff

- ^Ap-- 0 – 19 cm; olive brown (2.5Y 4/3) sandy loam; loose.
- ^C1-- 19 – 89 cm; yellowish red (5YR 5/6) sandy loam; loose.
- ^C2-- 89 – 105 cm; yellowish red (5YR 4/6) clay.
- ^C3-- 105 – 120 cm; strong brown (7.5YR 5/6) clay.
- ^C4-- 120 – 130+ cm; brownish yellow (10YR 6/6) sand.

Notes:

- ^Ap horizon: Medium gray clay bodies prominent throughout layer.
- ^C1 horizon: Medium red clay bodies evident throughout layer.
- ^C2 horizon: Red, firmer clay located above softer, orange/strong brown clay.
- ^C4 horizon: Sand is damp, however not saturated. Uniform in overall color and texture.

Auger boring: 201-5 (Topsoil); Date: 06/05/05; Sampled by: K. Meredith and Z. Orndorff

- ^Ap-- 0 – 7 cm; olive brown (2.5Y 4/3) sandy loam; loose.
- ^Apd-- 7 – 15 cm; dark gray brown (2.5Y 4/2) grades to light olive brown (2.5Y 5/4) sandy clay loam.
- ^C1-- 15 – 51 cm; reddish yellow (7.5YR 6/6) loamy sand with common, very coarse to extremely coarse, prominent, yellowish red (5YR 5/8) clay bodies.
- ^C2-- 51 – 79 cm; yellowish red (5YR 5/6) grades to strong brown (7.5YR 5/6) clay.
- ^C3-- 79 – 130+ cm; pale yellow (2.5Y 8/3) coarse sand.

Notes:

- ^Apd horizon: Dense layer--possible traffic pan.
- ^C1 horizon: Bodies are semi-firm. Color grades into C2 horizon.
- ^C2 horizon: More, larger, clay bodies than C1 horizon.
- ^C3 horizon: Greater than 35 % gravelly (≤ 5 mm) coarse fragments. Layer is as a mixture of quartz sand with Fe stains. Layer is saturated towards bottom 15 cm of horizon. Water has filled in auger boring.

Auger boring: 202-1 (Biosolids-No Tillage); Date: 06/05/05; Sampled by: K. Meredith and Z. Orndorff

- ^Ap-- 0 – 18 cm; strong brown (7.5YR 5/6) sandy loam with clay bodies with common, very coarse, prominent, yellowish red (10YR 4/2) and common, coarse, distinct, dark grayish brown (5YR 4/6) clay bodies.

- ^AC-- 18 – 52 cm; strong brown (7.5YR 5/8) sandy loam with clay bodies with common, very coarse, prominent, yellowish red (10YR 4/2) and common, coarse, distinct, dark gray brown (5YR 4/6) clay bodies.
- 2^C1-- 52 – 66 cm; strong brown (7.5YR 5/6) clay with common, medium to coarse, faint, dark gray brown (10YR 4/2) fragments of an A horizon.
- 2^C2-- 66 – 104 cm; strong brown (7.5YR 5/6) sandy loam with small to medium clay bodies.
- 2^C3-- 104 – 122 cm; strong brown (7.5YR 5/8) clay with sandy coatings with common, very coarse to extremely coarse, distinct, yellowish red (5YR 4/6) clay slime fragments.
- 2^C4-- 122 – 130 cm; reddish yellow (7.5YR 6/8) sand.

Notes:

- 2^C1 horizon: Red and gray soft clay bodies. Gray clay is firmer than reddish/orange clay.
- 2^C2 horizon: Small to medium yellowish red (5YR 5/6) and olive brown (2/5Y 4/3) clay bodies prominent.
- 2^C3 horizon: Firm red clay located over softer, siltier, orange/strong brown clay.
- 2^C4 horizon: Uniform in overall color and texture.

Auger boring: 202-2 (Biosolids-No Tillage); Date: 06/05/05; Sampled by: K. Meredith and Z. Orndorff

- ^Ap-- 0 – 27 cm; strong brown (7.5YR 4/6) grading to grayish brown (10YR 5/2) sandy loam; loose/very friable.
- ^C1-- 27 – 70 cm; dark yellowish brown (10YR 4/6) sandy clay loam.
- ^C2-- 43 – 70 cm; yellowish brown (10YR 5/4) sandy clay loam.
- ^C3-- 70 – 91 cm; dark yellowish brown (10YR 5/6) sandy loam with clay bodies with red (5YR 4/6), olive brown (2.5Y 4/3) brown and dark yellowish brown (10YR 4/4) clay bodies.
- ^C4-- 91 – 105 cm; brownish yellow (10YR 6/6) sand
- ^C5-- 105 – 130+ cm; yellowish red (5YR 5/8) sand.

Notes:

- ^Ap horizon: Strong sulfidic smell--most likely a result of biosolid treatment. Large chunks of black organic material evident throughout horizon.
- ^C5 horizon: Sand is slightly moist; however, no water appeared in auger boring.

Auger boring: 202-3 (Biosolids-No Tillage); Date: 06/05/05; Sampled by: K. Meredith and Z. Orndorff

- ^Ap1-- 0 – 30 cm; dark gray brown (10YR 4/2) sandy clay loam with common, medium to coarse, prominent, yellowish red (5YR 4/6) and common to many, medium, prominent, strong brown (7.5YR 4/6) bodies.
- ^Ap2-- 30 – 69; gray brown (10YR 4/2) sandy clay loam with common, medium to coarse, prominent, yellowish red (5YR 4/6) and common to many, medium, prominent, strong brown (7.5YR 4/6) bodies.
- ^C1-- 69 – 85; strong brown (7.5YR 5/6) clay.

- ^C2-- 85 – 120 cm; brownish yellow (10YR 6/6) grades to strong brown (7.5YR 5/6) sand with small to medium clay bodies.
- ^C3-- 120 – 130+ cm; yellowish red (5YR 4/6) clay.

Notes:

- ^Ap2 horizon: Dense layer with large amounts of red, gray and orange/strong brown clay bodies present throughout horizon. Wood organic material evident. Amount of clay bodies increase with depth. Strong sulfidic/biosolid odor present.
- ^C1 horizon: Soft, orange/strong brown clay with few sandy coatings evident throughout layer.
- ^C2 horizon: Small to medium red and yellowish red (5YR 4/6) clay bodies. Red clay bodies more prominent within lower 5 cm of horizon.
- ^C3 horizon: Firm, red clay with few sandy coatings prominent.

Auger boring: 202-4 (Biosolids-No Tillage); Date: 06/05/05; Sampled by: K. Meredith and Z. Orndorff

- ^Ap-- 0 – 15 cm; strong brown (7.5YR 4/6) sandy clay loam with common, medium, distinct, yellowish red (5YR 4/6) and common, medium, distinct, dark gray brown (10YR 5/6) bodies.
- 2^C1-- 15 – 42 cm; yellowish red (5YR 4/6) sandy clay loam with common, medium to coarse, prominent, olive brown (2.5Y 4/3) fragments of an A horizon.
- 3^C2-- 42 – 74 cm; strong brown (7.5YR 5/6) sandy loam with clay and sandy clay loam bodies with common, medium to coarse, prominent, gray/gleyed (N61) sandy clay loam bodies and common to many, coarse to very coarse, prominent, olive brown (2.5Y 4/3) clay bodies.
- 3^C3-- 74 – 115 cm; strong brown (10YR 5/6) grades to yellowish brown (7.5YR 5/8) clay to silty clay.
- 3^C4-- 115 – 130+ cm; brownish yellow (10YR 6/6) coarse sand.

Notes:

- ^Ap horizon: Colors appear mixed/variegated. Few, dark biosolid material prominent throughout horizon.
- 2^C1 horizon: Clay increases with depth.
- 3^C2 horizon: Roots prominent throughout horizon. Gray/gleyed bodies possess a Sulfidic smell--possibly due to biosolid treatment.
- 3^C3 horizon: Clay is soft, smooth, and “marbled.”
- 3^C4 horizon: Sand is moist but not saturated. Water did not fill in auger boring.

Auger boring: 202-5 (Biosolids-No Tillage); Date: 06/05/05; Sampled by: K. Meredith and Z. Orndorff

- ^Ap-- 0 – 19 cm; strong brown (7.5YR 5/8) sandy clay loam with common, medium, prominent, very dark gray (2.5Y 3/1) bodies.
- ^C1-- 19 – 78 cm; reddish yellow (7.5YR 6/6) grades to yellowish red (5YR 4/6) loamy sand with clay bodies.

- ^C2-- 78 – 116 cm; reddish yellow (5YR 6/6) grades to reddish yellow (7.5YR 6/6) clay.
^C3-- 116 – 130+ cm; pale yellow (2.5Y 8/3) very coarse sand.

Notes:

- ^Ap horizon: Dark, biosolid bodies evident.
- ^C1 horizon: Few, medium to large strong brown/orange, clay bodies prominent. Material possesses a strong sulfidic odor
- ^C2 horizon: Few sandy coatings along clay bodies. Softer, siltier clay prominent at bottom 5 to 10 cm of horizon. Strong sulfidic odor present.
- ^C3 horizon: Very wet/saturated horizon. Strong sulfidic smell present. Horizon is to be a mixture of quartz fragments and sand.

Auger boring: 203-1 (Control); Date: 06/05/05; Sampled by: K. Meredith and Z. Orndorff

- ^Ap-- 0 – 24 cm; strong brown (7.5YR 4/6) sandy loam with clay bodies with few, medium, prominent, dark grayish brown (2.5Y 4/2) bodies.
^AC-- 24 – 48 cm; dark gray brown (2.5Y 4/2) sandy loam.
^C1-- 48 – 106 cm; dark yellowish brown (10YR 4/6) sandy loam to loamy sand with clay bodies with few, medium, prominent yellowish red (5YR 5/8) clay bodies.
^C2-- 106 – 115 cm; yellow brown (10YR 5/4) grades to strong brown (7.5YR 5/8) clay.
^C3-- 115 – 130+ cm; strong brown (7.5YR 5/6) loamy sand.

Notes:

- ^AC horizon: Layer is predominantly dark gray bodies with few strong brown (7.5YR 4/6) sandy coatings.
- ^C1 horizon: Other shades of browns and grays evident throughout horizon. Layer is as mixed material--sand and clay bodies.
- ^C2 horizon: Few sandy coatings prominent along clay ped faces--possibly mixed from auger buckets.

Auger boring: 203-2 (Control); Date: 06/05/05; Sampled by: K. Meredith and Z. Orndorff

- ^Ap-- 0 – 5 cm; strong brown (7.5YR 4/6) sandy clay loam.
2^Cd-- 5 – 100 cm; strong brown (7.5YR 4/6) sandy clay loam with common, medium, distinct, yellowish red (5YR 5/6) few, medium, distinct, light gray (7.5YR 7/1) and common, medium to coarse, prominent, dark gray (10YR 4/1) fragments of an A horizon.
2^C-- 100 – 130+ cm; reddish yellow (7.5YR 7/6) sand; with clay bodies with common, coarse to very coarse, distinct, yellowish red (5YR 5/6) clay bodies.

Notes:

- 2^Cd horizon: Layer is dense.
- 2^C horizon: Horizon is wet/saturated.

Auger boring: 203-3 (Control); Date: 06/05/05; Sampled by: K. Meredith and Z. Orndorff

- ^Ap-- 0 – 23 cm; strong brown (7.5YR 4/6) sandy clay loam to sandy loam.
- ^AC-- 23 – 53 cm; strong brown (7.5YR 4/8) sandy clay loam to sandy loam.
- ^C1-- 53 – 60 cm; strong brown (7.5YR 4/6) clay.
- ^C2-- 61 – 85 cm; brownish yellow (10YR 6/8) loamy sand with few, small clay bodies.
- ^C3-- 85 – 104; strong brown (7.5YR 5/6) grades to yellowish red (5YR 4/6) clay with few small clay bodies.
- ^C4-- 104 – 130+ cm; brownish yellow (10YR 6/6) medium sand.

Notes:

- ^Ap horizon: Small to medium strong brown, gray and yellow clay bodies prominent throughout layer.
- ^AC horizon: Small to medium strong brown, gray and yellow clay bodies prominent throughout layer.
- ^C1 horizon: A thin, dense clay band occurs. Clay band has a slight sulfidic/biosolids odor.
- ^C3 horizon: Few small to medium gray/gleyed (N61) clay and sandy clay loam bodies. Overall color is variegated with strong brown (7.5YR 5/8) and grayish brown (2.5Y 5/2) bodies.
- ^C4 horizon: Few small to medium strong brown clay bodies present.

Auger boring: 203-4 (Control); Date: 06/05/05; Sampled by: K. Meredith and Z. Orndorff

- ^Ap-- 0 – 26 cm; yellowish red (5YR 5/6) grades to strong brown (7.5YR 5/6) sandy clay loam with clay bodies.
- ^AC-- 26 – 46 cm; yellowish red (5YR 5/8) grades to strong brown (7.5YR 5/8) sandy clay loam with clay bodies.
- ^C1-- 46 – 115 cm; strong brown (7.5YR 5/8) loamy sand with clay bodies with common, medium to coarse, distinct, yellowish red (5YR 5/8) clay bodies.
- ^C2-- 115 – 130+ cm; yellowish red (5YR 5/8) clay with sandy coatings.

Notes:

- ^Ap and ^AC horizons: Clay increases with depth. Few chunks of dark grayish brown (2.5Y 4/2) biosolids and woody organic matter evident throughout horizons.
- ^C2 horizon: Clay is soft, strong brown/orange in color.

Auger boring: 203-5 (Control); Date: 06/05/05; Sampled by: K. Meredith and Z. Orndorff

- ^Ap-- 0 – 10 cm; strong brown (7.5YR 4/6) sandy loam.
- ^C1-- 10 – 15 cm; strong brown (7.5YR 5/8) silty clay.
- ^C2-- 15 – 44 cm; strong brown (7.5YR 5/8) loamy sand.
- ^C3-- 44 – 100 cm; yellowish red (5YR 4/6) grades to strong brown (7.5YR 5/6) clay.
- ^C4-- 100 – 130+ cm; brownish yellow (10YR 6/8) medium sand with few clay bodies.

Notes:

- ^C3 horizon: Layer is dense. Semi-hard clay bodies predominantly located between 44 and 57 cm. Softer, siltier, clay occurs between 57 and 90 cm.

- ^C4 horizon: Sand is not saturated; however, water filled in auger boring. From 90 to 110 cm there was a mixture of horizons above and below. Reddish yellow (10YR 6/8), medium sand with few clay bodies.

Auger boring: 204-1 (Biosolids-Conventional Tillage); Date: 07/21/05; Sampled by: K. Meredith and M. Nester

- ^Ap-- 0 – 5 cm; strong brown (7.5YR 4/6) sandy clay loam.
- ^C1-- 5 – 45 cm; strong brown (7.5YR 5/8) sandy clay loam with clay bodies with few to common, medium, prominent, dark brown clay bodies (10YR 4/3).
- ^C2-- 45 – 75 cm; dark yellowish brown (10YR 4/6) sandy clay loam with few clay bodies.
- ^C3-- 75 – 130+ cm; dark yellowish brown (10YR 4/6) coarse sand with few clay bodies.

Notes:

- ^Ap horizon: Woody organic material and roots prevalent.

Auger boring: 204-2 (Biosolids-Conventional Tillage); Date: 07/21/05; Sampled by: K. Meredith and M. Nester

- ^Ap1-- 0 – 40 cm; strong brown (7.5YR 4/6) sandy clay loam with clay bodies with common, medium, prominent, dark gray brown (10YR 4/2) mottles.
- ^Ap2-- 40 – 80 cm; strong brown (7.5YR 4/6) sandy clay loam with clay bodies with common, medium, prominent, dark gray brown (10YR 4/2) mottles.
- 2^Cd-- 80 – 97 cm; yellowish red (5YR 5/6) clay with sandy coatings with common, medium prominent, dark gray brown (10YR 4/2) fragments of an A horizon.
- 2^C-- 97 – 130+ cm; strong brown (7.5YR 5/6) coarse sand with few, medium, faint strong brown (7.5YR 5/8) medium clay bodies.

Notes:

- ^Ap1 and ^Ap2 horizons: Organic matter and root masses prominent throughout horizon. A strong sulfidic odor present. Increase in medium to large grey/gleyed (N61) clay bodies toward bottom 15 cm of layer.
- 2^Cd horizon: Layer is dense.

Auger boring: 204-3 (Biosolids-Conventional Tillage); Date: 07/21/05; Sampled by: K. Meredith and M. Nester

- ^Ap-- 0 – 15 cm; strong brown (7.5YR 4/6) sandy loam/sandy clay loam; loose/very friable.
- ^C1-- 15 – 40 cm; yellowish brown (10YR 5/6) coarse sand with clay loam bodies friable.
- 2^C2-- 40 – 55 cm; dark greenish gray (5G 4/1) clay loam.
- 2^C3-- 55 – 85 cm; yellowish brown (10YR 5/8) grades to brownish yellow (10YR 6/6) coarse sand.
- 2^C4-- 85 – 100 cm; strong brown (7.5YR 5/6) clay with sandy coatings.
- 2^C5-- 100 – 130+ cm; yellowish brown (10YR 5/6) coarse sand.

Notes:

- ^Ap horizon: Organic matter scattered throughout horizon.
- 2^C2 horizon: Sand is prominent along clay ped faces.
- 2^C3 horizon: Color transitions between 10YR 5/8 and 10YR 6/6 across horizon.
- 2^C4 horizon: Sand is prominent along clay ped faces.
- 2^C5 horizon: Layer is saturated.

Auger boring: 204-4 (Biosolids-Conventional Tillage); Date: 07/21/05; Sampled by: K. Meredith and M. Nester

- ^Ap-- 0 – 30 cm; strong brown (7.5YR 4/6) sandy clay loam with few small to medium clay bodies; loose/very friable.
- ^C1-- 30 – 95 cm; strong brown (7.5YR 5/6) loamy sand; friable.
- ^C2-- 95 – 115 cm; yellowish red (5YR 4/6) clay.
- ^C3-- 115 – 130+ cm; yellowish brown (10YR 5/6) coarse sand.

Notes:

- ^Ap horizon: Roots prominent throughout the layer
- ^C1 horizon: Large amount of roots prominent. Few small clay bodies evident throughout layer.
- ^C2 horizon: Brown and red colored soft clay bodies coated with sand evident throughout layer.
- ^C3 horizon: Sand is wet/saturated. Water table was struck and water filled in auger boring.

Auger boring: 204-5 (Biosolids-Conventional Tillage); Date: 07/21/05; Sampled by: K. Meredith and M. Nester

- ^Ap-- 0 – 10 cm; dark yellowish brown (10YR 4/6) sandy clay loam; loose/very friable.
- ^C1-- 10 – 45 cm; strong brown (7.5YR 5/6) sand with few clay bodies.
- ^C2-- 45 – 95 cm; yellowish brown (10YR 5/8) clay.
- ^C3-- 95 – 130+ cm; strong brown (10YR 5/6) sand.

Notes:

- ^Ap horizon: Few roots evident.
- ^C2 horizon: Sand prominent along ped faces.
- ^C3 horizon: Layer is saturated. Water table was struck at 95 cm.

Auger boring: 301-1 (Biosolids-No Tillage); Date: 07/21/05; Sampled by: K. Meredith and M. Nester

- ^Ap-- 0 – 35 cm strong brown (7.5YR 4/6) sandy loam/sandy clay loam with common, coarse, distinct, dark gray brown (10YR 4/2) bodies.
- ^C1-- 35 – 85 cm; strong brown (7.5YR 4/8) sandy loam/sandy clay loam with common, coarse, distinct, dark gray brown (10YR 4/2) bodies.
- ^C2-- 85 – 130+ cm; yellowish brown (10YR 5/6) coarse sand.

Notes:

- ^Ap horizon: Strong sulfidic odor present--most likely a result of biosolid treatment. Few gray brown (10YR 6/1) clay bodies with sandy coatings present.
- ^C2 horizon: Damp layer with few small clay bodies. Quartz fragments and pebbles prominent throughout horizon.

Auger boring: 301-2 (Biosolids-No Tillage); Date: 06/05/05; Sampled by: K. Meredith and Z. Orndorff

^Ap-- 0 – 15 cm; strong brown (7.5YR 4/6) sandy clay loam.

^AC-- 15 – 69 cm; strong brown (7.5YR 5/6) sandy clay loam.

^C-- 69 – 130+ cm; reddish yellow (7.5YR 6/6) sand.

Notes:

- ^AC horizon: Texture becomes more segregated and redder with depth.
- ^C horizon: White sand prominent near bottom of horizon (between 120 and 125 cm).

Auger boring: 301-3 (Biosolids-No Tillage); Date: 05/05/05; Sampled by: K. Meredith and Z. Orndorff

^Ap1-- 0 – 30 cm; strong brown (7.5YR 5/6) sandy clay loam.

^Ap2-- 30 – 60 cm; strong brown (7.5YR 5/6) sandy clay loam.

^C1-- 60 – 120 cm; reddish yellow (7.5YR 6/8) sand with clay bodies.

^C2-- 120 – 130+ cm; yellowish red (5YR 5/8) sand with clay bodies.

Notes:

- ^Ap1 and ^Ap2 horizons: Accumulation of gray/gleyed (N61) clay bodies present throughout horizon. Few, layers of sand with clay bodies evident. Layer becomes sandier and clay decreases with depth.
- ^C1 horizon: Thin, brittle, yellowish red (5YR 4/6) clay band (< 5 cm thick) occurs at 90 cm.
- ^C2 horizon: Color is redder. Water filled in auger boring.

Auger boring: 301-4 (Biosolids-No Tillage); Date: 06/05/05; Sampled by: K. Meredith and Z. Orndorff

^Ap-- 0 – 15 cm; strong brown (7.5YR 4/6) sandy loam.

^C-- 15 – 53 cm; strong brown (7.5YR 4/8) loamy sand with clay bodies.

^Cd-- 53 – 72 cm; yellowish red (5YR 5/6) clay to silty clay with common, coarse to very coarse, distinct, strong brown (7.5YR 5/6) clay slime fragments.

^C1-- 72 – 98 cm; reddish yellow (7.5YR 6/6) sand.

^C2-- 98 – 130+ cm; very pale brown (10YR 7/4) coarse sand.

Notes:

- ^Ap horizon: Material is as a mixture of sandy loam with clay bodies.
- ^Cd horizon: Dense layer.

- ^C2 horizon: Sand is saturated at bottom of horizon.

Auger boring: 301-5 (Biosolids-No Tillage); Date: 06/05/05; Sampled by: K. Meredith and Z. Orndorff

- ^Ap1-- 0 – 58 cm; dark yellow brown (10YR 4/6) sandy loam with clay bodies.
- ^Ap2-- 0 – 58 cm; strong brown (10YR 4/8) sandy loam with clay bodies.
- ^C1-- 58 – 68 cm; strong brown (7.5YR 5/8) clay with common, very coarse, distinct, yellowish red (5YR 5/6) clay slime bodies.
- ^C2-- 68 – 82 cm; strong brown (7.5YR 5/6) clay with common, very coarse, distinct, yellowish red (5YR 5/6) clay slime bodies.
- ^C3-- 82 – 120 cm; brownish yellow (10YR 6/6) coarse sand.
- ^C4-- 120 – 130+ cm; brownish yellow (10YR 6/8) coarse sand.

Notes:

- ^Ap1 and ^Ap2 horizons: Few, small to medium red (5YR 4/6) and gray/gleyed (N61) clay bodies prominent throughout horizon.
- ^C1 horizon: Soft, smooth, silty-textured, clay.
- ^C3 horizon: Few, small clay bodies evident.
- ^C4 horizon: Layer becomes saturated towards bottom. Water table was struck.

Auger boring: 302-1 (Biosolids-Conventional Tillage); Date: 07/21/05; Sampled by: K. Meredith and M. Nester

- ^Ap1-- 0 – 40 cm; strong brown (7.5YR 4/6) sandy loam with common, medium, distinct, dark gray brown (10YR 4/2) bodies.
- ^Ap2-- 40 – 90 cm; strong brown (7.5YR 4/8) sandy loam with common, medium, distinct, dark gray brown (10YR 4/2) bodies.
- ^C-- 90 – 130+ cm; yellowish brown (10YR 5/6) coarse sand.

Notes:

- ^Ap1 and ^Ap2 horizons: Strong increase in clay bodies towards bottom 10 cm of horizon. Roots and woody organic material prominent throughout layer. Layer is dense.
- ^C horizon: Uniform in overall color. Few, small clay bodies prominent throughout horizon. Some pebbles evident towards bottom 10 cm.

Auger boring: 302-2 (Biosolids-Conventional Tillage); Date: 07/21/05; Sampled by: K. Meredith and M. Nester

- ^Ap-- 0 – 10 cm; strong brown (7.5YR 4/6) sandy clay loam; loose/very friable.
- ^AC-- 10 – 30 cm; strong brown (7.5YR 4/8) sandy clay loam.
- ^C1-- 30 – 65 cm; yellowish brown (10YR 5/8) sandy clay loam.
- ^C2-- 65 – 130+ cm; yellowish brown (10YR 5/6) sandy loam with few clay bodies; very friable to loose.

Notes:

- ^Ap horizon: Layer is loose/very friable throughout horizon.
- ^AC horizon: Large clay bodies and large to medium chunks of woody organic material prominent towards bottom half of layer.
- ^C1 horizon: Medium clay bodies present throughout horizon.
- ^C2 horizon: Sandier than previous C1 horizon. Clay bodies evident throughout layer.

Auger boring: 302-3 (Biosolids-Conventional Tillage); Date: 06/05/05; Sampled by: K. Meredith and Z. Orndorff

- ^Ap-- 0 – 30 cm; strong brown (7.5YR 5/6) sandy clay loam.
- ^C1-- 30 – 53cm; strong brown (7.5YR 5/8) sandy clay loam with common strong brown (7.5YR 5/6) clay bodies.
- ^C2-- 53 – 90 cm; reddish yellow (7.5YR 6/6) sand.
- ^C3-- 90 – 102 cm; yellowish red (5YR 4/6 over 5YR 5/6) clay to silty clay.
- ^C4-- 102 – 107 cm; brownish yellow (10YR 6/8) sand.
- ^C5-- 107 – 130+ cm; brownish yellow (10YR 6/6) sand.

Notes:

- ^Ap horizon: Dark gray brown (2.5Y 4/2) clay bodies prominent throughout horizon.
- ^C1 horizon: Dark gray brown clay bodies predominantly located between 30 and 41 cm, few dark surfaces and flakes of possible organic matter evident. Clay bodies dominant below 40 cm.
- ^C3 horizon: Layer is dense with firm, red clay bodies prominent in upper 5 cm of horizon. Red clay bodies are followed by dense, soft, smooth strong brown yellow clay bodies.

Auger boring: 302-4 (Biosolids-Conventional Tillage); Date: 06/05/05; Sampled by: K. Meredith and Z. Orndorff

- ^Ap-- 0 – 19 cm; reddish yellow (7.5YR 6/6) sandy loam with clay bodies and common, coarse, faint, strong brown (7.5YR 4/6) bodies.
- ^C1-- 19 – 58 cm; reddish yellow (7.5YR 8/6) sandy loam with clay bodies and common, coarse, faint, strong brown (7.5YR 4/6) clay slime fragments.
- ^C2-- 58 – 70 cm; strong brown (7.5YR 5/6) clay.
- ^C3-- 70 – 130+ cm; pale yellow (2.5Y 7/3) sand.

Notes:

- ^Ap horizon: Texture is as a mixture of two separate materials--clay bodies and sandy material within upper 10 cm of horizon.
- ^C1 horizon: More distinct clay bodies prominent towards bottom of horizon.
- ^C2 horizon: Clay is semi-soft, not hard or brittle.
- ^C3 horizon: A thin layer of orange/brown yellow (10YR 6/6) clay is located between 88 and 92 cm. Few strong brown (7.5YR 5/6) clay bodies evident in upper 5 cm of horizon. Auger boring filled with water; however, sand was not saturated.

Auger boring: 302-5 (Biosolids-Conventional Tillage); Date: 06/05/05; Sampled by: K. Meredith and Z. Orndorff

- ^Ap-- 0 – 15 cm; strong brown (7.5YR 5/6) sandy clay loam/sandy loam.
- ^C1-- 15 – 25 cm; yellow brown (10YR 5/6) loamy sand to sand with clay bodies.
- ^C2-- 25 – 43 cm; strong brown (7.5YR 5/6) grading to yellowish red (5YR 5/6) clay.
- ^C3-- 43 – 130+ cm; yellowish red (5YR 5/6) grades to light yellow red (2.5Y 6/3) clay to silty clay.

Notes:

- ^Ap horizon: Several beetles, ants, etc, observed at surface. Sandy loam texture with clay bodies. Bodies are not a distinct color--color varies between pale brown and red.
- ^C1 horizon: Similar color variations in clay bodies as auger 303-2.
- ^C2 horizon: Hard, dense, clay. Clay is as a mixture of two colors--“marbled,” mostly browner color mixed with red. Thin sand to sandy loam textured band occurs in the middle of layer.
- ^C3 horizon: Soft, moist, dense, clay--“marbled.”

Auger boring: 303-1 (Topsoil); Date: 06/05/05; Sampled by: K. Meredith and Z. Orndorff

- ^Ap-- 0 – 21 cm; very dark grayish brown (2.5Y 4/2) sandy loam with few, medium, prominent, yellow brown (10YR 4/6) and few, medium, distinct, light olive brown (2.5Y 5/4) clay bodies.
- 2^C1-- 21 – 57 cm; strong brown (7.5YR 5/6) sandy clay loam to sandy clay.
- 2^C2-- 57 – 130+ cm; strong brown (7.5YR 5/8) sand.
- 2^C3-- 120 – 130+ cm; yellowish brown (10YR 5/6) sand with many clay bodies.

Notes:

- ^Ap horizon: Some accumulation of organic matter.
- 2^C1 horizon: Yellowish red (5YR 4/6) and dark gray brown (2.5Y 4/2) clay accumulation prominent towards bottom of horizon.
- 2^C2 horizon: Clay bodies prominent towards upper 5 cm of horizon. Increase in red color evident towards bottom of layer.
- 2^C3 horizon: Strong accumulation of clay.

Auger boring: 303-2 (Topsoil); Date: 06/05/05; Sampled by: K. Meredith and Z. Orndorff

- ^Ap-- 0 – 18 cm; very dark grayish brown (2.5Y 4/2) sandy loam.
- 2^C1-- 18 – 69 cm; strong brown (7.5YR 5/6) sandy clay loam/sandy clay; less than 2 % gravelly coarse fragments.
- 2^C2-- 69 – 130+ cm; strong brown (7.5YR 5/6) grading to yellowish brown (10YR 5/6), sand; with clay bodies.

Notes:

- ^Ap horizon: Clumps and striations of black decaying organic matter evident. Few, light olive brown (2.5Y 5/4) sandy clay loam bodies prominent throughout horizon.

- 2^C1 horizon: Few, small gray (2.5Y 6/1) concentrations and common, small concentrations of yellow and pale brown bodies.
- 2^C2 horizon: Sand was not saturated; however, water filled in auger boring.

Auger boring: 303-3 (Topsoil); Date: 06/05/05; Sampled by: K. Meredith and Z. Orndorff

- ^Ap-- 0 – 23 cm; dark grayish brown (10YR 4/2) sandy loam.
 2^C1-- 23 – 42 cm; strong brown (7.5YR 5/8) sandy loam; with few, medium to coarse, prominent, very dark gray (10YR 3/1) clay bodies.
 2^C2-- 42 – 88 cm; yellowish red (5YR 5/8) grades to reddish yellow (7.5YR 6/8) medium sand with slight accumulation of red clay bodies.
 2^C3-- 88 – 97 cm; red (2.5YR 4/8) clay.
 2^C4-- 97 – 130+ cm; reddish yellow (7.5YR 6/8) sand; with few small to medium clay bodies.

Notes:

- ^Ap horizon: Layer is dense, especially below 8 to 10 cm--possible traffic pan. Light olive brown (2.5Y 5/4) striations on ped with few black (N2.5) striations--most likely a result of black organic matter.
- 2^C2 horizon: Clay bodies prominent towards upper 8 cm of horizon.
- 2^C4 horizon: Uniform in overall color. Clay bodies prominent towards bottom of horizon. Water table was struck at bottom 20 cm of horizon. Auger boring was not wet when hole was augered; however, hole filled with water later.

Auger boring: 303-4 (Topsoil); Date: 06/05/05; Sampled by: K. Meredith and Z. Orndorff

- ^Ap-- 0 – 18 cm; strong brown (7.5YR 5/6) sandy loam.
 2^C1-- 18 – 53 cm; yellow red (5YR 5/8) sand to loamy sand with common to many, coarse, to very coarse, distinct, strong brown (7.5YR 5/6) clay bodies and fragments.
 2^C2-- 53 – 70+ cm; pale yellow (2.5Y 8/2) sand.
 2^C3-- 70 – 130+ cm; very pale brown (10YR 7/4) sand.

Notes:

- ^Ap horizon: Topsoil material is uniform in overall texture and color.
- 2^C1 horizon: Between 18 to 53 cm, layer is as a mixture of red sand to loamy sand material with clay bodies. A thin band (<5 cm) of dense, red, clay prominent between 21 to 26 cm. Below 26 cm, brown to lighter brown small clay to clay loam bodies are evident.
- 2^C3 horizon: Material becomes increasingly wet, especially below 80 cm.

Auger boring: 303-5 (Topsoil); Date: 06/05/05; Sampled by: K. Meredith and Z. Orndorff

- ^Ap1-- 0 – 18 cm; olive brown (2.5Y 4/3) sandy loam.
 ^Ap2-- 18 – 34 cm; dark grayish brown (2.5Y 4/2) sandy loam.
 2^C-- 34 – 130+ cm; reddish yellow (7.5YR 6/6) coarse sand with common to many, coarse to very coarse, distinct, yellow red (5YR 5/8) bodies.

Notes:

- ^Ap1 horizon: Greater clay accumulation towards bottom of horizon. Layer is dense.
- ^Ap2 horizon: Nodules and chunks of woody organic material prominent throughout horizon.
- 2^C horizon: Water table was struck towards bottom 15 cm of horizon. Few, red clay bodies prominent in upper 8 cm of horizon.

Auger boring: 304-1 (Control); Date: 07/27/05; Sampled by: K. Meredith and M. Nester

- ^Ap-- 0 – 30 cm; strong brown (10YR 4/6) sandy clay loam with medium to large clay bodies.
 ^C-- 30 – 130+ cm; light olive brown (2.5Y 5/6) sand with common, coarse to very coarse, prominent strong brown (10YR 4/8) clay bodies.

Notes:

- ^C horizon: Clay bodies prominent towards top of horizon. Texture becomes sandier towards bottom.

Auger boring: 304-2 (Control); Date: 07/27/05; Sampled by: K. Meredith and M. Nester

- ^Ap-- 0 – 50 cm; strong brown (7.5YR 4/6) sandy clay loam with common to many, coarse, prominent, gray (10YR 5/1) clay bodies.
 ^AC-- 50 – 100 cm; strong brown (7.5YR 4/8) sandy clay loam with common to many, coarse, prominent, clay bodies.
 ^C-- 100 – 130+ cm; strong brown (7.5YR 5/6) coarse sand.

Notes:

- ^Ap and ^AC horizons: Clay bodies are coated in sand. Few chunks of dark biosolid matter prominent.
- ^C horizon: Sand is wet/saturated with few small strong brown (7.5YR 5/8) clay bodies. Water filled in auger boring.

Auger boring: 304-3 (Control); Date: 07/27/05; Sampled by: K. Meredith and M. Nester

- ^Ap-- 0 – 35 cm; dark yellowish brown (10YR 4/6) sandy clay loam with clay bodies.
 ^C-- 35 – 65 cm; strong brown (7.5YR 5/8) sand with few, medium to coarse, faint, strong brown (7.5YR 5/6) clay bodies.
 2^Ab-- 65 – 75 cm; brown/dark brown (7.5YR 4/4) sandy clay.
 3^C-- 75 – 130+ cm; olive yellow (2.5Y 6/6) sand.

Notes:

- ^Ap horizon: Root clumps and masses dominant in upper 10 cm of horizon. Clay bodies appear to diminish with depth.
- 2^Ab horizon: Sand lined ped faces.
- 3^C horizon: Occasional clay bodies evident throughout layer. Sand is saturated towards bottom of horizon. Water table was struck at 125 cm.

Auger boring: 304-4 (Control); Date: 06/05/05; Sampled by: K. Meredith and Z. Orndorff

- ^Ap-- 0 – 20 cm; dark yellow brown (10YR 4/6) sandy loam with common, medium, distinct yellowish red (5YR 5/6) clay bodies.
- ^C1-- 20 – 55 cm; strong brown (7.5YR 5/8) loamy sand with few to common, coarse to very coarse, prominent, yellowish brown (10YR 5/4) clay bodies.
- ^C2-- 55 – 62 cm; yellowish red (5YR 5/6) clay.
- ^C3-- 62 – 130+ cm; very pale brown (10YR 7/3) medium to coarse sand.

Notes:

- ^C2 horizon: A thin layer of dense, semi-soft, silty clay evident throughout horizon.
- ^C3 horizon: Sand is wet/saturated below 100 cm.

Auger boring: 304-5 (Control); Date: 06/05/05; Sampled by: K. Meredith and Z. Orndorff

- ^Ap-- 0 – 14 cm; red (2.5YR 5/6) sandy clay loam.
- ^C1-- 14 – 58 cm; strong brown (7.5YR 5/8) sand.
- ^C2-- 58 – 130+ cm; light yellow brown (2.5Y 6/3) and yellow (10YR 7/6) sand.

Notes:

- ^Ap horizon: An increase in red clay bodies towards occurs towards bottom of horizon.
- ^C2 horizon: Water table was struck at 100 cm.

Auger boring: 401-1 (Control); Date: 06/25/05; Sampled by: K. Meredith and M. Nester

- ^Ap-- 0 – 30 cm; yellowish red (5YR 4/6) sandy clay loam.
- ^C-- 30 – 130+ cm; strong brown (7.5YR 5/8) coarse sand.

Notes:

- ^Ap horizon: Very dense layer--possible traffic pan. Larger clay bodies evident towards bottom of horizon.
- ^C horizon: Occasional pockets of clay prevalent throughout horizon. Sand becomes saturated towards bottom of layer.

Auger boring: 401-2 (Control); Date: 06/25/05; Sampled by: K. Meredith and M. Nester

- ^Ap-- 0 – 10 cm; strong brown (7.5YR 5/8) sand.
- ^C1-- 10 – 25 cm; brownish yellow (10YR 6/6) sandy loam.
- ^C2-- 25 – 55 cm; strong brown (7.5YR 5/8) sand with medium (10YR 4/8) clay bodies with common to many, coarse, distinct, yellowish brown (10YR 5/8) clay bodies.
- ^C3-- 55 – 80 cm; brownish yellow (10YR 6/5) sand.
- ^C4-- 80 – 130+ cm; light yellowish brown (2.5Y 6/4) sand.

Notes:

- ^Ap horizon: Occasional peds of woody organic material prominent within upper 2 cm of horizon.

- ^C3 horizon: Occasional gray stains evident.
- ^C4 horizon: Sand becomes saturated at 110 cm.

Auger boring: 401-3 (Control); Date: 06/25/05; Sampled by: K. Meredith and M. Nester

- ^Ap-- 0 – 15 cm; strong brown (7.5YR 4/6) sandy loam with common, medium to coarse, faint, brown (7.5YR 4/4) clay bodies.
- ^C-- 15 – 130+ cm; olive yellow (2.5Y 6/6) sand.

Notes:

- ^Ap horizon: Clay bodies prominent within lower 5 cm or horizon.
- ^C horizon: Sand becomes saturated at 100 cm.

Auger boring: 401-4 (Control); Date: 06/25/05; Sampled by: K. Meredith and M. Nester

- ^Ap-- 0 – 28 cm; reddish yellow (7.5YR 4/4) sandy clay loam/sandy loam.
- ^C1-- 28 – 60 cm; strong brown (7.5YR 4/6) sandy clay loam.
- ^C2-- 60 – 110 cm; dark yellowish brown (10YR 4/6) clay.
- ^C3-- 110 – 130+ cm; light olive brown (2.5Y 5/6) sand.

Notes:

- ^C1 horizon: Color becomes light olive brown (2.5Y 5/6) near bottom 2 to 3 cm of horizon.
- ^C2 horizon: Occasional peds of light olive (2.5Y 5/6) sandy material within upper 40 cm of horizon.

Auger boring: 401-5 (Control); Date: 06/25/05; Sampled by: K. Meredith and M. Nester

- ^Ap-- 0 – 30 cm; brown/dark brown (7.5YR 4/4) sandy clay loam;
- ^C1-- 30 – 60 cm; strong brown (7.5YR 4/6) clay with common (2.4Y 5/6) sandy coatings along ped faces.
- ^C2-- 60 – 75 cm; strong brown (7.5YR 4/6) clay with sandy coatings and common, medium to coarse, prominent light olive brown (2.5Y 5/6) sandy coatings.
- ^C3 -- 75 – 90 cm; strong brown (7.5YR 4/6) clay.
- ^C4 -- 90 – 130+ cm; yellowish brown (10YR 5/6) sand.

Notes:

- ^Ap horizon: Layer is dense. Horizon becomes sandier towards bottom 5 cm.
- ^C1 horizon: Sandy coatings more prominent near bottom 10 cm of horizon.
- ^C3 horizon: Absence of sand within this layer.
- ^C4 horizon: Sandy clay bodies evident throughout horizon.

Auger boring: 402-1 (Topsoil); Date: 06/25/05; Sampled by: K. Meredith and M. Nester

- ^Ap-- 0 – 14 cm; dark grayish brown (2.5Y 4/2) sandy loam.
- ^AC-- 14 – 33 cm; strong brown (7.5YR 4/6) sandy clay loam with common, coarse, prominent, dark grayish brown (2.5Y 4/2) fragments of an A horizon.
- ^C1-- 33 – 48 cm; strong brown (7.5YR 4/6) clay with sandy coatings.
- ^C2-- 48 – 130+ cm; strong brown (7.5YR 5/6) coarse, medium to finer sand with common, medium to coarse, faint, strong brown (7.5YR 4/6) clay bodies.

Notes:

- ^Ap horizon: Dense layer, with small to medium clay bodies prominent.
- ^AC horizon: Very dense layer, with red and gray clay bodies. Few, small rock pebbles prominent within peds.
- ^C1 horizon: Layer is mostly red clay with few sandy coatings and particles. Few, small rock pebbles evident within peds.
- ^C2 horizon: Medium to fine sand prominent towards upper half of horizon with coarser sand prominent towards lower 40 cm. Large, clay bodies evident within upper 5 cm of horizon.

Auger boring: 402-2 (Topsoil); Date: 06/25/05; Sampled by: K. Meredith and M. Nester

- ^Ap-- 0 – 20 cm; strong brown (7.5YR 4/6) sandy loam with common, medium, distinct, dark brown (7.5YR 3/2) mottles, and common, small to medium, prominent, dark grayish brown (2.5Y 4/2) mottles.
- 2^C-- 20 – 130 cm; yellowish brown (10YR 5/6) clay with sandy coatings and common, medium to coarse, distinct, strong brown (7.5YR 4/6) fragments of a Bt horizon.

Notes:

- ^Ap horizon: Dense layer, with moist, wet clay and dark chunks of organic matter prominent. Strong biosolid smell. Moisture retention on surface evident; however, no ponding of water occurred.
- 2^C horizon: Sandy coatings prominent toward upper 10 cm of horizon. Dense layer. Harder, firmer, red, clay prominent towards top of layer, with softer, wetter, smoother clay prominent towards bottom.

Auger boring: 402-3 (Topsoil); Date: 06/25/05; Sampled by: K. Meredith and M. Nester

- ^Ap-- 0 – 23 cm; dark grayish brown (2.5Y 4/2) sandy loam with large clay bodies.
- 2^C1-- 23 – 73 cm; yellowish brown (10YR 5/6) fine sand with common, medium to coarse, prominent, red (5YR 4/4) clay bodies.
- 2^C2-- 73 – 130+ cm; yellowish brown (10YR 5/6) fine sand with common, medium to coarse, prominent, dark grayish brown (2.5Y 4/2) clay bodies.

Notes:

- ^Ap horizon: Large clay bodies prominent towards bottom 10 cm of horizon. A thin gleyed (N6/1) band occurs at 15 cm. Woody organic material prevalent.

Auger boring: 402-4 (Topsoil); Date: 06/25/05; Sampled by: K. Meredith and M. Nester

- ^Ap-- 0 – 15 cm; dark grayish brown (2.5Y 4/2) sandy loam with clay bodies and common, medium, prominent, red (5YR 4/4) clay bodies.
- 2^C-- 15 – 130+ cm; yellowish brown (10YR 5/6) coarse sand with small clay bodies and common, coarse, prominent, light yellowish brown (2.5Y 6/4) fragments of an A horizon.

Notes:

- ^Ap horizon: Large dark grayish brown (2.5Y 4/2) sandy coated clay bodies prevalent towards bottom 5 cm of horizon. Layer is very dense--difficult to auger.
- 2^C horizon: Dense layer. Coarse sand prominent within middle to upper part of horizon. Finer, tighter, denser sand prevalent towards bottom. Mottles evident towards bottom of horizon only.

Auger boring: 402-5 (Topsoil); Date: 06/25/05; Sampled by: K. Meredith and M. Nester

- ^Ap-- 0 – 30 cm; dark gray brown (10YR 4/2) sandy loam.
- 2^C1-- 30 – 120 cm; reddish brown (5YR 4/4) coarse sand with common, medium to coarse, distinct, yellowish red (5YR 5/8) clay bodies.
- 2^C2-- 120 – 130+ cm; reddish brown (5YR 4/4) clay; with common to many yellowish red (5YR 5/8) sandy coatings.

Notes:

- ^Ap horizon: Very dense layer with a slight accumulation of biosolid material. Woody organic matter evident.
- 2^C1 horizon: Reddish brown sand with medium clay bodies evident within upper 5 cm of horizon.
- 2^C2 horizon: Orange/strong brown clay coated with reddish brown coarse sandy coatings.

Auger boring: 403-1 (Biosolids-Conventional Tillage); Date: 06/25/05; Sampled by: K. Meredith

- ^Ap1-- 0 – 30 cm; strong brown (5YR 4/6) sandy clay loam with clay bodies and common, medium, faint, reddish brown (5YR 4/4) mottles.
- ^Ap2-- 30 – 60 cm; strong brown (5YR 4/6) sandy clay loam with clay bodies with common, medium, faint, reddish brown (5YR 4/4) mottles.
- ^C-- 60 – 130+ cm; brownish yellow (10YR 6/6) coarse sand with small red clay bodies, and large, soft, brown clay bodies and common to many, coarse to very coarse, distinct, yellow brown (10YR 5/8) clay bodies.

Notes:

- ^Ap1 and ^Ap2 horizons: Dark grayish brown (10YR 4/2) woody organic matter prevalent at surface. Increase in clay bodies towards bottom of horizon.

- ^C horizon: Lighter, whiter, color more prominent towards bottom of layer.

Auger boring: 403-2 (Biosolids-Conventional Tillage); Date: 06/25/05; Sampled by: K. Meredith

^Ap1-- 0 – 30 cm; strong brown (5YR 4/6) sandy clay loam with clay bodies.

^Ap2-- 30 – 60 cm; strong brown (5YR 4/6) sandy clay loam with clay bodies.

^C-- 60 – 130+ cm; brownish yellow (10YR 6/6) coarse sand with clay bodies and common, coarse to very coarse, distinct, yellowish brown (10YR 5/8) clay bodies,

Notes:

- ^Ap1 and ^Ap2 horizons: Increase in clay bodies towards bottom of layer. Few, chunks of woody organic material prominent.
- ^C horizon: Small, red clay bodies prominent towards top of horizon. Lighter color more prominent towards bottom of horizon. Wet/saturated sand. Sand becomes wetter towards bottom of horizon. Water filled in auger boring after auguring was completed.

Auger boring: 403-3 (Biosolids-Conventional Tillage); Date: 06/25/05; Sampled by: K. Meredith

^Ap-- 0 – 20 cm; strong brown (7.5YR 5/6) loamy sand with clay bodies.

^C1-- 20 – 75 cm; strong brown (7.5YR 5/6) clay with sandy coatings with common, very coarse, prominent, reddish brown (5YR 4/4) sandy coatings.

^C2-- 75 – 130+ cm; brownish yellow (10YR 6/6) coarse sand with few clay bodies.

Notes:

- ^Ap horizon: Clay bodies evident throughout horizon.
- ^C1 horizon: More sandy coatings prevalent towards top of horizon. Smooth, fine, silty, orange/strong brown clay evident throughout profile.
- ^C2 horizon: Clay bodies are more prominent towards top of horizon. Sand is wet towards bottom of layer. Water table was struck at 110 cm.

Auger boring: 403-4 (Biosolids-Conventional Tillage); Date: 06/25/05; Sampled by: K. Meredith

^Ap1-- 0 – 20 cm; strong brown (7.5YR 5/6) sandy loam.

^Ap2-- 20 – 36 cm; strong brown (7.5YR 5/8) sandy loam.

^C1-- 36 – 80 cm; brownish yellow (10YR 6/6) sand with clay bodies.

^C2-- 80 – 130+ cm; brownish yellow (10YR 6/6) grades to reddish brown (5YR 4/4) clay.

Notes:

- ^Ap2 horizon: More clay accumulation towards bottom 10 cm of layer. Some black organic matter evident throughout horizon.
- ^C1 horizon: Layer is as a mixture of moist, wet sand with small orange, brown and red clay bodies.
- ^C2 horizon: Soft, silty-textured. Orange/strong brown and red variegated clay.

Auger boring: 403-5 (Biosolids-Conventional Tillage); Date: 06/25/05; Sampled by: K. Meredith

- ^Ap-- 0 – 15 cm; strong brown (5YR 4/6) sandy loam with few large clay bodies.
- ^C1-- 15 – 60 cm; reddish brown (5YR 4/4) coarse sand with small to medium clay bodies with common, medium to coarse, prominent, strong brown (7.5YR 5/6) fragments of a Bt horizon.
- ^C2-- 60 – 130+ cm; brownish yellow (10YR 6/6) sand.

Notes:

- ^Ap horizon: Clay bodies prominent towards bottom of horizon.
- ^C1 horizon: Clay bodies are soft, reddish brown clay.
- ^C2 horizon: Sand is lighter, finer-textured than previous C1 layer until 90 cm. At 90 cm, sand becomes very coarse and wet. Water table was struck at 90 cm.

Auger boring: 404-1 (Biosolids-No Tillage); Date: 07/05/05; Sampled by: K. Meredith

- ^Ap-- 0 – 24 cm; strong brown (7.5YR 5/8) sandy clay loam.
- ^C1-- 24 – 104 cm; reddish yellow (7.5YR 6/8) sand grades to yellow (10YR 7/6).
- ^C2-- 104 – 117 cm; yellow (10YR 8/6) coarse sand.
- ^C3-- 117 – 130+ cm; strong brown (7.5YR 5/8) fine sand.

Notes:

- ^Ap horizon: Layer is dense but not root restricting.
- ^C1 horizon: Finer-textured sand prominent towards top of horizon with coarser, wetter sand prominent towards bottom. Sand is wet/saturated with few medium clay bodies.

Auger boring: 404-2 (Biosolids-No Tillage); Date: 07/05/05; Sampled by: K. Meredith

- ^Ap-- 0 – 28 cm; yellowish red (5YR 5/6) sandy loam with clay bodies with common, medium, prominent, grayish brown (10YR 5/2) mottles.
- ^C1-- 28 – 47 cm; strong brown (7.5YR 5/6, 7.5YR 5/8) sandy loam;
- ^C2-- 47 – 89 cm; brownish yellow (10YR 6/8) sand.
- ^C3-- 89 – 130+ cm; yellowish red (5YR 5/8) sand.

Notes:

- ^Ap horizon: Clay bodies vary in color when broken apart. Dark organic matter prevalent within top layer--possible biosolids.
- ^C1 horizon: Dense clay band located at bottom 3 cm of horizon. Overall horizon is to be coarse sand with few small to medium clay bodies.

Auger boring: 404-3 (Biosolids-No Tillage); Date: 07/05/05; Sampled by: K. Meredith

^Ap-- 0 – 20 cm; strong brown (7.5YR 5/8) sandy loam with common, medium to coarse, prominent, dark gray (7.5YR 4/1) organic matter bodies.

^C-- 20 – 130+ cm; yellow (10YR 7/8) sand grading to yellow (10YR 7/6) coarse sand.

Notes:

- ^Ap horizon: Dense layer with dense clay/organic matter bodies evident throughout horizon. Bodies appear mixed with chunks of biosolids.
- ^C horizon: Lighter color prominent towards bottom half of horizon with redder colors more prominent towards top. Water table was struck at 115 cm.

Auger boring: 404-4 (Biosolids-No Tillage); Date: 07/05/05; Sampled by: K. Meredith

^Ap1-- 0 – 25 cm; strong brown (7.5YR 5/6) sandy loam grading to reddish yellow (7.5YR 6/8).

^Ap2-- 25 – 45 cm; strong brown (7.5YR 5/6) sandy loam grading to reddish yellow (7.5YR 6/8).

^C-- 45 – 130+ cm; reddish yellow (7.5YR 6/6) clay grading to yellowish red (5YR 5/6).

Notes:

- ^Ap1 and ^Ap2 horizons: Chunks of organic matter evident throughout horizon.
- ^C horizon: Soft, silty, smooth clay.

Auger boring: 404-5 (Biosolids-No Tillage); Date: 07/05/05; Sampled by: K. Meredith

^Ap-- 0 – 30 cm; strong brown (7.5YR 5/8) sandy loam with few to common, medium, prominent, gray (7.5YR 4/1) mottles.

^C1-- 30 – 80 cm; reddish yellow (7.5YR 6/8) coarse sand.

^C2-- 80 – 130+ cm; yellow (10YR 7/6), coarse sand.

Notes:

- ^Ap horizon: Dense towards bottom 10 cm of horizon. Large chunks of biosolid material prominent. Strong/sulfidic odor. A thin (< 5 cm) clay band is located towards bottom 5 cm of horizon.
- ^C2 horizon: Water table was struck at 95 cm. Sand is saturated near bottom.

Auger boring: EC 1-1 (Compacted Area); Date: 07/28/05; Sampled by: K. Meredith and M. Nester

^Ap1-- 0 – 20 cm; brown (7.5YR 4/4) sandy clay loam with common, medium, prominent, yellowish red (5YR 4/6) and common to many, medium to coarse, prominent, gray brown (10YR 5/2) mottles.

^Ap2-- 20 – 40 cm; brown (7.5YR 4/4) sandy clay loam with common, medium, prominent, yellowish red (5YR 4/6) and common to many, medium to coarse, prominent, gray brown (10YR 5/2) mottles.

- 2^C1-- 40 – 103 cm; yellowish red (5YR 4/6) sandy loam/sandy clay loam with common, coarse to very coarse, prominent, dark gray brown (10YR 4/2) fragments of an A horizon; loose/very friable.
- 3^C2-- 103 – 117 cm; yellowish brown (10YR 5/8) sand; with few, small clay bodies.
- 3^C3-- 117 – 130+ cm; light yellowish brown (2.5Y 6/4) coarse sand.

Notes:

- ^Ap1 and ^Ap2 horizons: Layer is dense, with lots of roots and clay bodies towards upper 15 cm of horizon. Few, red, brittle clay bodies towards bottom half of horizon.
- 2^C1 horizon: Roots and woody organic material prominent throughout horizon. Few, small to medium clay bodies evident. Lighter colors appear towards upper 20 cm of horizon.
- 3^C3 horizon: Sand is light-colored and moist, but not saturated.

Auger boring: EC 1-2 (Compacted Area); Date: 07/28/05; Sampled by: K. Meredith and M. Nester

- ^Ap1-- 0 – 15 cm; yellowish brown (10YR 5/4) sandy loam; loose/very friable.
- ^Ap2-- 15 – 40 cm; dark brown (10YR 4/3) sandy clay loam with medium clay bodies.
- ^C-- 40 – 70 cm; dark yellowish brown (10YR 4/6) sandy clay loam with medium clay bodies.
- 2^Ab-- 70 – 80 cm; dark gray (7.5YR 4/1) sandy clay loam.
- 3^C-- 80 – 130+ cm; brownish yellow (10YR 6/6) sand.

Notes:

- ^Ap1 and ^Ap2 horizons: High amount of root masses evident throughout horizon. Small clay bodies prominent in lower 5 cm of layer. Few roots prominent towards top 15 cm of horizon. Woody organic matter scattered throughout layer.
- ^C horizon: Medium clay bodies prominent throughout layer.
- 2^Ab horizon: Layer is as a distinct and gray transition area between ^C horizon above and 3^C horizon below.
- 3^C horizon: Few, small clay bodies prominent throughout layer.

Auger boring: EC 2-1 (Compacted Area); Date: 08/02/05; Sampled by: K. Meredith and M. Nester

- ^Ap-- 0 – 30 cm; dark yellowish brown (10YR 4/4) sandy loam.
- ^C1-- 30 – 60 cm; yellowish red (5YR 5/6) sandy clay with clay bodies with common, coarse to very coarse, distinct, strong brown (7.5YR 4/6) and few to common, medium to coarse, prominent, dark grayish brown (10YR 4/2) fragments of an A horizon.
- ^C2-- 60 – 130+ cm; yellowish red (5YR 5/8) sandy clay with clay bodies with common, coarse to very coarse, distinct, strong brown (7.5YR 4/6) and few to common, medium to coarse, prominent, dark grayish brown (10YR 4/2) fragments of an A horizon; loose/very friable.

Notes:

- ^Ap horizon: Some rooting prominent throughout horizon. Darkened woody organic material evident.
- ^C1 horizon: Medium, strong brown clay bodies prominent throughout layer. A large amount of root masses prominent.

Auger boring: EC 2-2 (Compacted Area); Date: 08/02/05; Sampled by: K. Meredith and M. Nester

- ^Ap1-- 0 – 15 cm; dark gray brown (10YR 4/2) sandy loam.
- ^Ap2-- 15 – 31 cm; dark brown (10YR 4/3) sandy loam.
- 2^C1-- 61 – 100 cm; dark gray brown (10YR 4/2) sandy clay with common, very coarse, distinct, very dark gray (10YR 3/1) fragments of an A horizon.
- 3^C2-- 100 – 110 cm; yellowish brown (10YR 6/8) sand with common, medium, prominent, dark red (2.5YR 4/6) clay bodies.
- 3^C3-- 110 – 130+ cm; yellowish brown (10YR 5/8) sand with common, medium, prominent, dark red (2.5YR 4/6) clay bodies.

Notes:

- ^Ap1 horizon: Few, small to medium red (5YR 5/6) clay bodies prominent within lower 30 cm of horizon.
- 2^C1 horizon: Rooting prominent within upper 20 cm of horizon. Material is dark and topsoil-colored--possible buried A horizon.
- 3^C2 horizon: Color is variegated. Few, small clay bodies prominent throughout horizon.
- 3^C3 horizon: Few, small clay bodies prominent throughout horizon. Sand is more evident towards bottom 15 cm of horizon.

Auger boring: EC 3-1 (Compacted Area); Date: 08/02/05; Sampled by: K. Meredith and M. Nester

- ^Ap1-- 0 – 30 cm; dark yellowish brown (10YR 4/4) sandy loam with medium clay bodies.
- ^Ap2-- 30 – 55 cm; dark yellowish brown (10YR 4/3) sandy loam with medium clay bodies.
- 2^C1-- 55 – 90 cm; dark yellowish brown (10YR 4/3) sandy clay loam with few to common, coarse, distinct, yellow brown (10YR 4/6) fragments of an A horizon.
- 2^C2 -- 90 – 130+ cm; dark yellow brown (10YR 4/3) sandy clay loam with clay bodies.

Notes:

- ^Ap1 horizon: Clay bodies prominent throughout layer with frequent root masses in upper 15 cm of horizon.
- 2^C1 horizon: Smaller clay bodies than previous Ap2 horizon.
- 2^C2 horizon: Clay bodies increase in with horizon depth. Sandy coating prominent along clay aggregate ped faces. Clay bodies predominantly appear towards bottom 30 cm of horizon.

Auger boring: EC 3-2 (Compacted Area); Date: 08/02/05; Sampled by: K. Meredith and M. Nester

- ^Ap1-- 0 – 70 cm; dark gray brown (10YR 4/2) sandy loam with medium to coarse clay bodies.
- ^Ap2-- 30 – 70 cm; dark gray brown (10YR 4/2) sandy loam with medium to coarse clay bodies.
- 2^Ab-- 70 – 100 cm; very dark gray (10YR 3/1) silt loam/silty clay loam;
- 3^C2-- 100 – 119 cm; yellowish brown (10YR 5/6) coarse sand.
- 3^C3-- 119 – 130+ cm; dark red (2.5YR 4/6) clay.

Notes:

- ^Ap1 horizon: Roots prominent throughout horizon.
- 2^Ab horizon: Layer is finer textured than previous ^Ap1 horizon. Large chunks of dark colored woody organic material prevalent throughout horizon.
- 3^C3 horizon: Soft, clay coated in sand. Layer is variable in color and overall coarseness.

Auger boring: EC 4-1 (Compacted Area); Date: 08/02/05; Sampled by: K. Meredith and M. Nester

- ^Ap1-- 0 – 30 cm; dark yellow brown (10YR 4/6) and (10YR 4/4) sandy loam with clay bodies.
- ^Ap2-- 30 – 56 cm; strong brown (10YR 4/8) and (10YR 4/4) sandy loam with clay bodies.
- ^C1-- 56 – 95 cm; strong brown (7.5YR 5/6) sandy loam with common, coarse to very coarse, distinct, dark brown (7.5YR 4/2) clay bodies.
- ^C2-- 95 – 130+ cm; light olive brown (2.5Y 5/6) sand with coarse clay bodies.

Notes:

- ^Ap1 and ^Ap2 horizons: Roots prominent throughout first 30 cm of horizon. Small to medium clay bodies evident. Clay bodies increase in size towards bottom 20 cm of horizon.
- ^C1 horizon: Slightly looser material than above (^Ap2) horizon. Clay content increases with depth. Strong biosolid/sulfur odor present.

Auger boring: EC 4-2 (Compacted Area); Date: 09/16/05; Sampled by: Kelly Meredith

- ^Ap1-- 0 – 42 cm; dark gray brown (10YR 4/2) grades to strong brown (7.5YR 4/6) sandy loam with few to common, medium, prominent, very dark gray (N31) mottles.
- ^Ap2-- 42 – 82 cm; dark gray brown (10YR 4/3) grades to strong brown (7.5YR 4/8) sandy loam with few to common, medium, prominent, very dark gray (N31) mottles.
- 2^C1-- 82 – 97 cm; strong brown (7.5YR 4/6) clay loam with common, medium to coarse, prominent, dark gray brown (10YR 4/2) fragments of an A horizon.
- 3^C2-- 97 – 130+ cm; strong brown (7.5YR 5/6) sand with common, very coarse, distinct, yellowish red (5YR 5/6) clay slime bodies.
- 3^C3-- 125 – 130+ cm; yellowish red (5YR 5/6) sand.

Notes:

- ^Ap1 and ^Ap2 horizons: Light gray, dark gray and some red small clay bodies prominent throughout layer. Sulfur smell--most likely a result of biosolid treatments evident. Few, small, rounded river cobbles (< 2mm) prominent throughout layer.
- 2^C1 horizon: Large amounts of woody organic material and thick roots prominent with dark, medium topsoil-colored clay bodies.
- 3^C2 horizon: Sand is moist, but not saturated. Layer is uniform in overall texture.
- 3^C3 horizon: Color is redder than previous C1 horizon.

Auger boring: EC 5-1 (Compacted Area); Date: 09/16/05; Sampled by: Kelly Meredith

^Ap-- 0 – 42 cm; strong brown (7YR 4/6) and (7YR 5/6) sandy loam.
 ^C-- 42 – 61 cm; yellowish red (5YR 5/6) fine sand.
 2^Ab-- 61 – 74 cm; dark gray brown (10YR 4/2) sandy loam with clay bodies.
 3^C1-- 74 – 120 cm; strong brown (7YR 4/6) sandy loam with clay bodies.
 3^C2-- 120 – 130+ cm; yellowish red (5YR 5/6) coarse sand.

Notes:

- ^Ap horizon: Uniform in overall texture.
- ^C horizon: Red, fine sand and few, small, red clay bodies prominent.
- 2^Ab horizon: Few, red and gray clay bodies evident. Organic matter and roots prominent throughout horizon.
- 3^C1 horizon: Red clay bodies with sandy coatings prominent throughout band. A thin clay layer (3 to 5 cm wide) is at 100 cm.

Auger boring: EC 5-2; Date: 08/02/05; Sampled by: K. Meredith and M. Nester

^Ap-- 0 – 15 cm; dark yellow brown (7.5YR 4/4) sandy loam with small clay bodies.
 ^AC-- 15 – 30 cm; strong brown (7.5YR 4/6) sandy loam with small clay bodies.
 ^C1-- 30 – 87 cm; strong brown (7.5YR 4/6) clay loam with medium to coarse sandy coated clay bodies.
 2^C2 -- 87 – 109 cm; strong brown (7.5YR 5/6) coarse sand.
 2^C3 -- 109 – 130+ cm; reddish yellow (7.5YR 6/8) coarse sand.

Notes:

- ^Ap horizon: Roots evident throughout horizon.
- ^AC horizon: Roots evident throughout horizon.
- ^C1 horizon: Roots prominent within upper 10 cm of horizon. Increase in clay bodies towards bottom 20 cm.
- 2^C2 horizon: Few, small, clay bodies and roots prominent throughout horizon.
- 2^C3 horizon: Sand is moist, but not saturated with few, small clay bodies evident.

Auger boring: EC 6-1 (Compacted Area); Date: 08/02/05; Sampled by: K. Meredith and M. Nester

- ^Ap1-- 0 – 30 cm; dark gray brown (10YR 4/2) sandy loam with small to medium clay bodies and common, medium to coarse, faint, dark yellow brown (10YR 4/4) mottles.
- ^Ap2-- 30 – 68 cm; dark gray brown (10YR 4/3) sandy loam with small to medium clay bodies and common, medium to coarse, faint, dark yellow brown (10YR 4/4) fragments of an A horizon.
- 2^C1-- 68 – 88 cm; dark yellow brown (10YR 5/8) sandy loam with small to medium clay bodies.
- 2^C2-- 88 – 103 cm; strong brown (7.5YR 5/6) fine sand with common, medium to coarse, distinct, reddish yellow (7.5YR 6/8) clay slime bodies.
- 2^C3-- 103 – 130+ cm; reddish yellow (7.5YR 6/8) coarse sand.

Notes:

- ^Ap1 and ^Ap2 horizons: Few roots present throughout horizon. Woody organic material increases with depth. Few, red, brittle clay bodies prominent.
- 2^C1 horizon: Woody organic material increases with depth. Few, red, brittle clay bodies prominent.
- 2^C3 horizon: Sand is moist, and coarser than previous 2^C2 horizon. Sand is comparable to small quartz fragments.

Auger boring: EC 6-2 (Compacted Area); Date: 08/02/05; Sampled by: K. Meredith and M. Nester

- ^Ap-- 0 – 15 cm; brown (10YR 4/3) sandy loam.
- 2^C1-- 15 – 64 cm; brown (10YR 4/3) sandy loam with common, medium to coarse, faint, dark yellow brown (10YR 4/6) fragments of an A horizon.
- 3^C2-- 64 – 110 cm; reddish yellow (7.5YR 6/8) sand.
- 3^C3-- 110 – 130+ cm; reddish yellow (7.5YR 6/8) coarse sand with olive yellow (2.5Y 6/6) fragments of an A horizon.

Notes:

- ^Ap horizon: Roots prominent throughout layer.
- 2^C1 horizon: Small to medium clay bodies evident.
- 3^C2 horizon: Occasional clay bodies present throughout layer.
- 3^C3 horizon: Sand is coarser than 3^C2 horizon.

Auger boring: EC 7-1 (Compacted Area); Date: 09/16/05; Sampled by: Kelly Meredith

- ^Ap1-- 0 – 25 cm; dark yellow brown (10YR 4/4) sandy loam with common, medium, prominent, yellowish red (5YR 5/6) clay mottles; loose/very friable.
- ^Ap2-- 25 – 41 cm; dark yellow brown (10YR 4/6) sandy loam; loose/very friable.
- ^C1-- 41 – 87 cm; strong brown (7.5YR 4/6, 7.5YR 5/6) sandy clay loam; loose/very friable.
- ^C2-- 87 – 92 cm; yellowish red (5YR 5/6) fine sand.
- ^C3-- 92 – 115+ cm; yellowish red (5YR 5/6) coarse sand.

Notes:

- ^Ap1 horizon: Small, gray and red clay bodies noted throughout horizon.
- ^C1 horizon: Medium red clay bodies apparent throughout horizon. Few to no roots evident.
- ^C3 horizon: Coarser sand more prominent towards bottom half of horizon. Numerous pebbles and rounded river rocks evident. Layer is moist, but not saturated.

Auger boring: EC 7-2 (Compacted Area); Date: 07/28/05; Sampled by: K. Meredith and M. Nester

- ^Ap1-- 0 – 30 cm; strong brown (7.5YR 4/6) grading to brown (10YR 5/3) sandy loam with medium clay bodies.
- ^Ap2-- 30 – 60 cm; strong brown (7.5YR 4/6) grading to brown (10YR 5/3) sandy loam with medium clay bodies.
- 2^C-- 60 – 100 cm; strong brown (7.5YR 5/8) coarse sand with common, very coarse, prominent, light yellowish brown (2.5Y 6/4), brownish yellow (10YR 6/6) fragments of an A horizon; loose/very friable.
- 3^C-- 100 – 130+ cm; strong brown (7.5YR 6/8) coarse sand; loose/very friable.

Notes:

- ^Ap1 and ^Ap2 horizons: Dense layer, with small to medium clay bodies prominent throughout horizon. Roots and flakes of woody organic matter evident.
- 2^C horizon: Color is variegated. A thin band of quartz-colored sand (< 5 cm) occurs at 75 cm.
- 3^C horizon: Sand is coarser and wetter than previous 2^C horizon.

Auger boring: EC 8-1 (Compacted Area); Date: 07/28/05; Sampled by: K. Meredith and M. Nester

- ^Ap1-- 0 – 30 cm; strong brown (7.5YR 4/6) sandy clay loam with common to many, coarse to very coarse, prominent, yellowish brown (10YR 5/8) mottles.
- ^Ap2-- 30 – 70 cm; strong brown (7.5YR 4/8) sandy clay loam with common to many, coarse to very coarse, prominent, yellowish brown (10YR 5/8) mottles.
- ^C-- 70 – 130+ cm; brownish yellow (10YR 6/6) coarse sand.

Notes:

- ^Ap1 and ^Ap2 horizons: Clay bodies present throughout layer. Clay bodies become massive before sand contact--C horizon.
- ^C horizon: Sand becomes coarser with depth. Few, small clay bodies prominent towards upper 20 cm of horizon.

Auger boring: EC 8-2 (Compacted Area); Date: 07/28/05; Sampled by: K. Meredith and M. Nester

- ^Ap-- 0 – 78 cm; strong brown (7.5YR 4/6) sandy clay loam.
- 2^C1-- 78 – 104 cm; strong brown (7.5YR 5/8) coarse sand; loose/very friable.
- 2 ^C2-- 104 – 130+ cm; yellowish brown (10YR 5/6) medium sand; loose/very friable.

Notes:

- ^Ap horizon: Dense layer. Few, small to medium clay bodies apparent. A large amount of root masses and woody organic material prominent throughout horizon.
- 2^C1 horizon: Slight variance in overall color.
- 2^C2 horizon: Layer is moist/damp, but not saturated.

Auger boring: EC 9-1 (Compacted Area); Date: 07/28/05; Sampled by: K. Meredith and M. Nester

- ^Ap1-- 0 – 35 cm; dark yellowish brown (10YR 4/4) sandy loam with clay bodies and common, coarse to very coarse, distinct, yellowish brown (10YR 5/8) mottles.
- ^Ap2-- 35 – 65 cm; dark yellowish brown (10YR 4/6) sandy loam with clay bodies and common, coarse to very coarse, distinct, yellowish brown (10YR 5/8) mottles.
- ^C1-- 65 – 120 cm; brownish yellow (10YR 6/8) sand.
- ^C2-- 120 – 130+ cm; brownish yellow (10YR 6/6) sand.

Notes:

- ^Ap1 and ^Ap2 horizons: Clay bodies prominent throughout layer. Clay bodies appear to increase in with horizon depth.
- ^C1 horizon: Small clay bodies evident towards upper 15 cm of horizon.

Auger boring: EC 9-2 (Compacted Area); Date: 07/28/05; Sampled by: K. Meredith and M. Nester

- ^Ap1-- 0 – 37 cm; strong brown (7.5YR 4/6) sandy clay loam.
- ^Ap2-- 37 – 57 cm; strong brown (7.5YR 4/8) sandy clay loam.
- 2^C1-- 57 – 94 cm; yellowish brown (10YR 5/6) sand with clay bodies with common, very coarse, faint, brownish yellow (10YR 6/6) fragments of an A horizon; very friable.
- 2^C2-- 94 – 130+ cm; yellowish brown (10YR 5/8) sand with clay bodies with common, very coarse, faint, brownish yellow (10YR 6/6) and (10YR 5/6) fragments of an A horizon; very friable.

Notes:

- ^Ap1 horizon: Roots and woody organic material evident throughout horizon.
- ^Ap2 horizon: Similar to above ^Ap1 horizon; however, strong increase in clay bodies.
- 2^C1 horizon: Color is variegated. Few, small, clay bodies prominent throughout layer. Overall, clay is coarse, brittle and hard.
- 2^C2 horizon: Similar to above 2^C1 horizon; however, strong increase in rock fragments.

Auger boring: EC 10-1 (Compacted Area); Date: 07/28/05; Sampled by: K. Meredith and M. Nester

- ^Ap1-- 0 – 10 cm; dark yellowish brown (10YR 4/4) sandy loam.
- ^Ap2-- 10 – 45 cm; dark yellowish brown (10YR 4/6) sandy loam.
- ^C1-- 45 – 95 cm; brownish yellow (10YR 6/6) sand with clay bodies.
- ^C2-- 95 – 130+ cm; brownish yellow (10YR 6/6) sand with few clay bodies.

Notes:

- ^Ap1 horizon: Roots prominent throughout horizon.
- ^Ap2 horizon: Roots prominent within upper 10 cm of horizon. Common, coarse to very coarse clay bodies prominent throughout layer. Clay becomes very dense at interface with sand contact.
- ^C1 horizon: Small clay bodies prominent throughout horizon.
- ^C2 horizon: Clay bodies decrease with depth.

Auger boring: EC 10-2 (Compacted Area); Date: 07/28/05; Sampled by: K. Meredith and M. Nester

- ^Ap-- 0 – 23 cm; strong brown (7.5YR 4/6) sandy clay loam with clay bodies.
- ^C1-- 23 – 43 cm; strong brown (7.5YR 5/6) sandy clay loam with clay bodies.
- 2^C2-- 43 – 130+ cm yellowish brown (10YR 5/6) sand with common, coarse to very coarse, prominent, olive yellow (2.5Y 6/6) fragments of an A horizon.

Notes:

- ^Ap horizon: Ample root masses and chunks of dark organic matter/biosolid material present.
- ^C1 horizon: Increase in clay bodies than previous ^Ap horizon.
- 2^C2 horizon: Sand is moist but not saturated.

Auger boring: EC 11-1 (Compacted Area); Date: 07/28/05; Sampled by: K. Meredith and M. Nester

- ^Ap1-- 0 – 20 cm; dark yellowish brown (10YR 4/4) sandy clay loam/sandy loam with common, medium, faint, yellowish brown (10YR 5/6) mottles.
- ^Ap2-- 20 - 48 cm; dark yellowish brown (10YR 4/6) sandy clay loam/sandy loam with common, medium, faint, yellowish brown (10YR 5/6) mottles.
- ^C1-- 48 – 65 cm; olive yellow (2.5Y 6/6) sand.
- ^C2-- 65 – 85 cm; light olive brown (2.5Y 5/6) sandy clay loam.
- ^C3-- 85 – 106 cm; yellowish brown (10YR 5/6) clay.
- ^C4-- 106 – 130+ cm; yellowish brown (10YR 5/8) clay.

Notes:

- ^Ap1 horizon: Dense layer--possible traffic pan.
- ^Ap2 horizon: Color becomes lighter closer to sand contact.

- ^C1 horizon: Few, clay bodies present throughout layer.
- ^C2 horizon: Few, loose, clay bodies prominent throughout horizon.
- ^C3 horizon: Sandy coatings apparent along ped faces.
- ^C4 horizon: Sandy coatings apparent along ped faces.

Auger boring: EC 11-2 (Compacted Area); Date: 07/28/05; Sampled by: K. Meredith and M. Nester

- ^Ap1-- 0 – 20 cm; strong brown (7.5YR 5/6) sandy clay loam/sandy loam.
- ^Ap2-- 20 – 60 cm; strong brown (7.5YR 4/6) sandy clay loam/sandy loam.
- ^C-- 60 – 130+ cm; yellow brown (10YR 5/6) sand; with light yellowish brown (2.5Y 6/4) and olive yellow (2.5Y 6/6) clay bodies.

Notes:

- ^Ap1 horizon: Dense layer – not root limiting. Roots and woody organic material apparent.
- ^Ap2 horizon: Roots and woody organic material apparent in upper 10 cm of horizon. Strong increase in clay bodies towards bottom of horizon.
- ^C horizon: Layer is variegated, with varying colors. Fine sand with some roots and medium to coarse red clay bodies present.

Auger boring: EC 12-1 (Compacted Area); Date: 08/02/05; Sampled by: K. Meredith and M. Nester

- ^Ap1-- 15 – 39 cm; strong brown (7.5YR 4/6) sandy clay loam.
- ^Ap2-- 15 – 39 cm; strong brown (7.5YR 4/8) sandy clay loam.
- ^C-- 39 – 130+ cm; strong brown (7.5YR 5/6) sand.

Notes:

- ^Ap1 and ^Ap2 horizons: Coarse to very coarse clay bodies apparent throughout layer.
- ^C horizon: Occasional clay layers and bands prominent throughout horizon.

Auger boring: EC 12-2 (Compacted Area); Date: 09/16/05; Sampled by: Kelly Meredith

- ^Ap-- 0 – 30 cm; dark strong brown (7.5YR 4/6) sandy loam.
- ^C1-- 30 – 38 cm; strong brown (7YR 4/6) clay; with soft, red and brown clay.
- ^C2-- 38 – 115+ cm; light yellowish brown (10YR 6/4) fine sand.

Notes:

- ^Ap horizon: Dense layer with some roots and woody organic material accumulation towards bottom 15 cm of horizon. Strong accumulation of sand towards bottom 15 cm of horizon.
- ^C1 horizon: Layer is as a mixture of soft, red, brown and orange clay with sandy coatings.
- ^C2 horizon: Light-colored, fine, moist sand with small, dark, gray clay bodies prominent throughout horizon.

Auger boring: C1-1 (Clarke Farm); Date: 07/11/05; Sampled by: K. Meredith and M. Nester

Ap-- 0 – 30 cm; olive brown (2.5Y 4/4) sandy loam; loose/very friable.
Bt1-- 30 – 55 cm; dark yellow brown (10YR 5/6) sandy clay loam.
Bt2-- 45 – 55 cm; yellowish red (5YR 5/6) sandy clay loam.
Bt3-- 55 – 130+ cm; dark red (2.5YR 3/6) clay loam with moderate medium subangular blocky structure.

Notes:

- Ap horizon: Roots prominent throughout horizon.
- Bt3 horizon: Larger clay blocks prominent towards bottom 10 cm of horizon.

Auger boring: C1-2 (Clarke Farm); Date: 07/11/05; Sampled by: K. Meredith and M. Nester

Ap-- 0 – 30 cm; olive brown (2.5Y 4/4) sandy loam; loose/very friable.
Bt1-- 30 – 45 cm; strong brown (7.5YR 4/6) sandy loam with moderate medium subangular blocky structure.
Bt2-- 45 – 130+ cm; dark red (2.5Y 3/6) clay.

Notes:

- Ap horizon: Black organic matter and roots evident throughout layer. Thicker roots located towards bottom 5 cm of horizon.
- Bt1 horizon: Few, medium clay blocks prominent throughout horizon.
- Bt2 horizon: Uniform in overall color. Few, sandy coatings on outer ped surfaces. Layer is dense. Organic matter and thick roots prominent in upper 10 cm of horizon.

Auger boring: C1-3 (Clarke Farm); Date: 07/11/05; Sampled by: K. Meredith and M. Nester

Ap-- 0 – 35 cm; olive brown (2.5Y 4/4) sandy loam; loose/very friable.
Bt1-- 35 – 45 cm; strong brown (7.5YR 4/6) clay loam.
Bt2-- 45 – 130+ cm; dark red (2.5YR 3/6) clay loam.

Notes:

- Ap horizon: Occasional dense clay bodies evident. Frequent masses of roots prominent throughout horizon.
- Bt1 horizon: Similar to previous Ap layer except horizon contains smaller clay blocks. Roots present throughout most of horizon.

Auger boring: C1-4 (Clarke Farm); Date: 07/11/05; Sampled by: K. Meredith and M. Nester

Ap-- 0 – 40 cm; olive brown (2.5Y 4/4) sandy loam; loose/very friable.

Bt-- 40 – 130+ cm; yellowish red (5YR 4/6) grades to dark red (2.5YR 3/6) clay loam.

Notes:

- Ap horizon: Soil appears healthy with frequent masses of roots throughout layer.
- Bt horizon: Increase in clay towards bottom 15 cm of horizon. Clay peds are hard and brittle with a light reddish hue prominent towards top. Darker reddish hues evident towards bottom of horizon.

Auger boring: C1-5 (Clarke Farm); Date: 07/11/05; Sampled by: K. Meredith and M. Nester

Ap-- 0 – 30 cm; olive brown (2.5Y 4/3) sandy loam to sandy clay loam.

Bt1-- 30 – 35cm; strong brown (7.5YR 4/6) clay loam to sandy clay loam.

Bt2 -- 35 – 130+ cm; dark red (2.5YR 3/6) clay loam with moderate medium subangular blocky structure.

Notes:

- Bt2 horizon: Larger clay blocks prominent towards bottom 20 cm of horizon.

Auger boring: C2-1 (Clarke Farm); Date: 07/11/05; Sampled by: K. Meredith and M. Nester

Ap-- 0 – 35 cm; olive brown (2.5Y 4/4) sandy loam; loose/very friable

Bt1-- 35 – 60 cm; strong brown (7.5YR 4/6) silty loam with moderate medium subangular blocky structure.

Bt2-- 60 – 130+ cm; dark red (2.5YR 3/6) clay loam.

Notes:

- Ap horizon: Roots prominent throughout horizon. Small, loamy bodies evident towards bottom.
- Bt1 horizon: Roots prominent throughout horizon.
- Bt2 horizon: Occasional roots prominent throughout layer. Coarse subangular blocky structure evident towards bottom 15 cm of horizon.

Auger boring: C2-2 (Clarke Farm); Date: 07/11/05; Sampled by: K. Meredith and M. Nester

Ap-- 0 – 40 cm; olive brown (2.5Y 4/4) sandy clay loam; loose/very friable.

Bt-- 40 – 130+ cm; reddish brown (5YR 4/4) clay loam/clay with moderate medium subangular blocky structure and common, medium to coarse, dark red (2.5YR 3/6) subangular blocks.

Notes:

- Ap horizon: Root masses and organic matter prevalent throughout layer.
- Bt horizon: Large amount of roots prominent throughout horizon. Horizon becomes redder towards bottom with lighter brownish/reddish colors located towards top. Increase

in clay content towards bottom half of layer. Few sand particles on clay peds. Layer is dense.

Auger boring: C2-3 (Clarke Farm); Date: 07/12/05; Sampled by: K. Meredith and M. Nester

Ap-- 0 – 30 cm; olive brown (2.5Y 4/3) sandy loam; loose/very friable.

Bt-- 30 – 130+ cm; strong brown (7.5YR 4/6) clay loam with common, medium to coarse, prominent, dark red (2.5YR 3/6) subangular blocks.

Notes:

- Ap horizon: Roots evident throughout horizon. Clay bodies prominent towards bottom of horizon.
- Bt horizon: Lighter color more prominent towards upper half of horizon.

Auger boring: C2-4 (Clarke Farm); Date: 07/12/05; Sampled by: K. Meredith and M. Nester

Ap-- 0 – 40 cm; olive brown (2.5YR 4/3) sandy loam/loamy sand with medium channels and subangular blocks; loose/very friable.

Bt1-- 40 – 85 cm; dark brown (7.5YR 4/4) clay loam with moderate medium subangular blocky structure.

Bt2-- 85 – 130+ cm; dark red (2.5Y 3/6) clay loam with moderate medium subangular blocky structure.

Notes:

- Ap horizon: Roots prevalent throughout horizon. Medium clay bodies prominent towards bottom half of layer.
- Bt1 horizon: Large masses of clay blocks prominent throughout layer. Rooting stopped at approximately 45 cm.

Auger boring: C2-5 (Clarke Farm); Date: 07/12/05; Sampled by: K. Meredith and M. Nester

Ap-- 0 – 40 cm; olive brown (2.5Y 4/4) sandy loam; loose/very friable.

Bt-- 40 – 130+ cm; strong brown (7.5YR 4/6) clay and common, coarse, prominent, dark red (2.5YR 5/6) subangular blocky structure.

Notes:

- Ap horizon: Roots prevalent throughout horizon.
- Bt horizon: A strong increase in dense, brittle, red clay colors towards bottom half of horizon. Clay increases with depth.

Auger boring: C3-1 (Clarke Farm); Date: 07/12/05; Sampled by: K. Meredith and M. Nester

Ap-- 0 – 30 cm; olive brown (2.5Y 4/4) sandy loam; loose/very friable.
Bt-- 30 – 130+ cm; strong brown (7.5YR 4/6) clay loam with few coarse subangular blocks and common, coarse to very coarse, dark red (2.5YR 3/6) subangular blocks.

Notes:

- Ap horizon: Organic material and roots prominent throughout horizon.
- Bt horizon: Lighter color more prominent at top half of horizon. Rooting evident within upper 30 cm. Large clay blocks occur towards bottom half of layer.

Auger boring: C3-2 (Clarke Farm); Date: 07/12/05; Sampled by: K. Meredith and M. Nester

Ap-- 0 – 32 cm; olive brown (2.5Y 4/4) sandy loam; loose/very friable.
Bt1-- 32 – 43 cm; strong brown (7.5YR 4/6) clay loam; with moderate medium subangular blocks.
Bt2-- 43 – 130+ cm; dark red (3.5YR 4/6) clay.

Notes:

- Ap horizon: Roots and organic matter prominent throughout horizon.
- Bt2 horizon: Increase in dark, red, firm clay blocks towards bottom 30 cm of layer.

Auger boring: C3-3 (Clarke Farm); Date: 07/12/05; Sampled by: K. Meredith and M. Nester

Ap-- 0 – 25 cm; olive brown (2.5Y 4/4) sandy loam with coarse redder clay blocks; loose/very friable.
Bt-- 25 – 130+ cm; yellowish red (5YR 4/6) clay loam with common, coarse, dark red (2.5YR 3/6) subangular blocks.

Notes:

- Ap horizon: Roots prominent throughout layer. Clay blocks evident towards bottom half of horizon.
- Bt horizon: Very dense layer. Clay becomes more sticky/plastic towards bottom 30 cm of horizon. Lighter color prominent within upper half of horizon. Darker, redder color more prominent towards bottom.

Auger boring: C3-4 (Clarke Farm); Date: 07/12/05; Sampled by: K. Meredith and M. Nester

Ap-- 0 – 39 cm; olive brown (2.5Y 4/3) sandy loam/loamy sand with red clay blocks; loose/very friable.
Bt-- 39 – 130+ cm; dark red (2.5YR 3/6) and dark red (2.5YR 4/6) sandy clay loam with common, very coarse, reddish brown (5YR 4/4) subangular blocks.

Notes:

- Ap horizon: Strong accumulation of medium reddish clay blocks evident towards bottom 15 cm of horizon. Roots and organic matter prominent throughout layer.
- Bt horizon: Increase in clay towards bottom half of horizon. Redder, harder, firmer, more brittle clay prominent towards bottom of layer. Lighter, browner clay evident towards upper half of horizon. Layer is dense with some rooting and organic matter only evident in upper 50 cm.

Auger boring: C3-5 (Clarke Farm); Date: 07/12/05; Sampled by: K. Meredith and M. Nester

Ap-- 0 – 35 cm; olive brown (2.5YR 4/4) sandy loam; loose/very friable.

Bt-- 35 – 130+ cm; strong brown (7.5YR 4/6) clay with common to many, medium to coarse, prominent, dark red (2.5YR 3/6) subangular blocks.

Notes:

- Ap horizon: Few, small clay blocks evident towards bottom half of horizon. Roots and organic material prominent throughout layer.
- Bt horizon: Increase in red clay color and clay content towards bottom 25 cm of horizon. Lighter, orange/strong brown color is towards upper part of horizon. Layer is dense-- could only fill ½ auger bucket.

Auger boring: C4-1 (Clarke Farm); Date: 07/12/05; Sampled by: K. Meredith and M. Nester

Ap-- 0 – 40 cm; olive brown (2.5Y 4/4) sandy loam; loose/very friable.

Bt1-- 40 – 65 cm; strong brown (7.5YR 4/6) sandy loam.

Bt2-- 65 – 130+ cm; dark red (2.5YR 3/6) clay.

Notes:

- Ap horizon: Large amounts of roots and organic matter prominent throughout layer.
- Bt1 horizon: Orange, strong brown color with few clay blocks evident towards bottom half of horizon.
- Bt2 horizon: Increase in medium red, firm, brittle, hard clay blocks with sandy coatings towards bottom 20 cm of horizon. Uniform in overall color. Layer is dense.

Auger boring: C4-2 (Clarke Farm); Date: 07/12/05; Sampled by: K. Meredith and M. Nester

Ap-- 0 – 20 cm; olive brown (2.5Y 4/3) sandy loam; loose/very friable.

Bt1-- 20 – 40 cm; olive (5Y 4/4) silty loam.

Bt2-- 40 – 80 cm; reddish brown (5YR 4/6) clay loam.

Bt3-- 80 – 130+ cm; dark red (2.5YR 3/6) clay loam.

Notes:

- Ap horizon: Roots evident throughout horizon.
- Bt1 horizon: Larger clay blocks than previous Ap layer. Clay blocks appear more clayey towards bottom half of horizon.

Auger boring: C4-3 (Clarke Farm); Date: 07/12/05; Sampled by: K. Meredith and M. Nester

Ap-- 0 – 40 cm; olive brown (2.5Y 4/4) sandy loam/loamy sand; loose/very friable.
 Bt-- 40 – 130+ cm; strong brown (7.5YR 4/6) clay with sandy coatings with common, coarse, dark red (2.5YR 3/6) subangular blocks.

Notes:

- Ap horizon: Large amounts of organic matter prominent throughout layer, uniform in overall color and texture.
- Bt horizon: Increase in clay content towards bottom. Lighter, orange/strong brown color more prominent towards upper 20 cm of horizon with redder, more brittle/firm clay towards bottom half of horizon. Organic matter and roots evident throughout horizon.

Auger boring: C4-4 (Clarke Farm); Date: 07/12/05; Sampled by: K. Meredith and M. Nester

Ap-- 0 – 30 cm; olive brown (2.5Y 4/4) sandy loam; loose.
 Bt1-- 30 – 50 cm; strong brown (7.5YR 4/6) clay loam.
 Bt2-- 50 – 130+ cm; dark red (2.5YR 3/6) clay loam.

Notes:

- Ap horizon: Large aggregation of clay blocks towards bottom half of horizon.
- Bt1 horizon: Large abundance of clayey blocks towards bottom half of layer.

Auger boring: C4-5 (Clarke Farm); Date: 07/12/05; Sampled by: K. Meredith and M. Nester

Ap-- 0 – 42 cm; olive brown (2.5Y 4/4) sandy loam; loose/very friable.
 Bt-- 42 – 130+ cm; strong brown (7.5YR 4/6) sandy loam to clay loam with depth; moderate medium subangular blocks.

Notes:

- Ap horizon: Frequent masses of roots and organic matter prominent throughout layer.
- Bt horizon: Strong increase in clay towards bottom half of horizon. Roots and organic matter evident throughout layer.

Appendix G
Soil Pit Sample Data (Summer 2006)

Table G-1 – Horizon depths, roots per horizon, soil texture, percent clay and soil pH in all pedons described at the CWRF over the summer of 2006.

Plot ID	Horizon	Depth to Lower Boundary (cm)	Treatment	Roots/cm ²	NRCS Root/Abund. Class	Texture	% Clay	% Sand	% Silt	pH
101-4	^Ap	6	Bio-NT	0.5	MF*	SCL	25	65	10	7.9
	^C1	46	Bio-NT	0.3	MF	SCL	25	65	10	5.1
	^C2	68	Bio-NT	0.8	MF	C	61	16	24	4.9
	2^C3	80	Bio-NT	0.1	VF**	S	5	89	6	5.3
	2^C4	140+	Bio-NT	.	.	S	2	95	3	5.4
102-3	^Ap1	10	Bio-CT	0.5	MF	SL	15	67	18	7.7
	^Ap2	36	Bio-CT	0.4	MF	SL	18	60	22	5.4
	^Bw	60	Bio-CT	0.2	MF	LS	11	83	6	4.9
	^C1/Bw	82	Bio-CT	.	.	C	66	22	12	4.8
	2^C2	120	Bio-CT	.	.	S	2	95	3	5.0
	2^C3	140+	Bio-CT	.	.	S	1	98	1	4.9
103-2	^Ap	5	Control	0.2	MF	SL	17	72	11	7.2
	^A	52	Control	0.3	MF	SL	12	73	15	6.2
	2^C1	60	Control	0.4	MF	SL	12	61	27	6.7
	3^C2	68	Control	0	VF	S	4	95	2	6.1
	3^C3	86	Control	.	.	SCL	28	64	8	5.2
	3^C4	130+	Control	.	.	S	2	98	0	6.1
104-5	^Ap1	7	Topsoil	0.1	VF	SL	18	60	22	6.8
	^Ap2	26	Topsoil	0.5	MF	SL	17	61	22	5.9
	2^Bw	50	Topsoil	2	C***	SCL	23	65	12	5.2
	2^C1	72	Topsoil	.	.	C	41	43	16	5.1
	2^C2	130+	Topsoil	.	.	S	1	97	2	5.2
201-2	^Ap1	10	Topsoil	0.5	MF	SL	17	65	18	7.3
	^Ap2	19	Topsoil	0	VF	SL	19	69	12	7.5
	^Abd1	30	Topsoil	.	.	SL	15	75	10	6.5
	^Abd2	59	Topsoil	.	.	SL	19	70	11	5.4
	2^C1	90	Topsoil	.	.	S	2	94	4	6.3
	2^C2	130+	Topsoil	.	.	S	0	97	3	5.1
202-1	^Ap1	7	Bio-NT	0.3	MF	SL	18	70	12	7.7
	^Ap2	25	Bio-NT	0.9	VF	SL	18			7.1
	2^Bwu	61	Bio-NT	.	.	SL	15	74	11	5.6
	3^BC	101	Bio-NT	.	.	SL	14	77	9	5.1
	3^C	130+	Bio-NT	.	.	S	2	98	0	5.2

Table G-1 Cont'd – Horizon depths, roots per horizon, soil texture, percent clay and soil pH in all pedons described at the CWRF over the summer of 2006.

Plot ID	Horizon	Depth to Lower Boundary (cm)	Treatment	Roots/cm ²	NRCS Root/Abund. Class	Texture	% Clay	% Sand	% Silt	pH
203-3	^Ap	7	Control	0.6	MF	SCL	22	69	9	7.5
	^Bw	30	Control	0.2	MF	SL	18	73	9	5.8
	^Cd	59	Control	0	VF	SL	17	75	8	5.0
	2^C1	81	Control	.	.	S	3	96	1	5.1
	2^C2/C1	102	Control	.	.	SCL	23	71	6	4.8
	2^C3	130+	Control	.	.	S	2	97	1	5.8
204-3	^Ap	9	Bio-CT	0.5	MF	SL	19	71	10	8.0
	^Bw1	34	Bio-CT	0.3	MF	SL	15	77	8	6.9
	^Bw2	58	Bio-CT	0.3	MF	SL	16	76	8	4.9
	^C1	69	Bio-CT	0.3	MF	SL	16	80	4	4.9
	^C2	92	Bio-CT	.	.	S	3	96	1	5.4
	2^C3	104	Bio-CT	.	.	C	59	20	21	4.7
	2^C4	130+	Bio-CT	.	.	S	4	95	1	5.5
301-3	^Ap	10	Bio-NT	0.7	MF	SCL	24	66	10	7.8
	^Bw1	20	Bio-NT	0.3	MF	SCL	26	65	9	6.8
	^Bw2	64	Bio-NT	0.3	MF	SCL	30	58	12	4.7
	^C1	97	Bio-NT	.	.	SL/LS	13	82	5	5.0
	^C2	130+	Bio-NT	.	.	S	1	97	2	4.8
302-3	^Ap	12	Bio-CT	0.3	MF	SCL	25	64	11	7.8
	^Bw1	44	Bio-CT	0.7	MF	SCL	24	66	10	5.2
	^Bw2	73	Bio-CT	0.3	MF	SL	14	80	6	4.8
	^C1	104	Bio-CT	.	.	S	6	92	2	5.1
	^C2	120+	Bio-CT	.	.	S	3	95	2	5.1
303-2	^Apu	12	Control	1	MF	SL	16	62	22	7.2
	^Ap	21	Control	0.7	MF	SCL	21	63	16	6.0
	^Bw	70	Control	0.1	VF	L	19	51	30	5.0
	^C1	87	Control	.	.	S	5	93	2	5.1
	^C2	130+	Control	.	.	S	2	97	1	5.5
304-1	^Ap	12	Topsoil	0.3	MF	SCL	21	67	12	7.4
	^A/C	43	Topsoil	0.3	MF	SCL	22	67	12	7.0
	^C1	78	Topsoil	0.1	VF	SCL/SL	21	68	11	4.9
	2^C2	100	Topsoil	.	.	SIC/C	43	18	39	5.0
	3^C3	130+	Topsoil	.	.	S	3	95	2	5.2

Table G-1 Cont'd – Horizon depths, roots per horizon, soil texture, percent clay and soil pH in all pedons described at the CWRF over the summer of 2006.

Plot ID	Horizon	Depth to Lower Boundary (cm)	Treatment	Roots/cm ²	NRCS Root/Abund. Class	Texture	% Clay	% Sand	% Silt	pH
401-5	^Ap	15	Topsoil	0.7	MF	SL	19	72	9	6.7
	^C1	44	Topsoil	0.1	VF	S	7	91	2	5.5
	^C2	72	Topsoil	.	.	S	5	91	4	5.6
	2^C3	110+	Topsoil	.	.	SIC/C	47	14	39	5.1
402-3	^Ap	8	Control	0.7	MF	SL	14	73	13	7.1
	^C1/C2	40	Control	0.4	MF	SL	16	74	10	6.7
	^Cu	100+	Control	.	.	S	0	96	4	6.2
403-5	^Ap	10	Bio-CT	0.4	MF	SL/LS	13	96	1	7.6
	^A	23	Bio-CT	0.3	MF	LS	11	83	6	7.7
	2^C1	62	Bio-CT	0.2	VF	SCL	25	65	10	5.1
	2^C2	200+	Bio-CT	.	.	SCL/SL	20	72	8	5.1
404-1	^Ap	11	Bio-NT	0.7	MF	SCL	33	53	14	7.6
	^Bw	22	Bio-NT	0.2	VF	SL	19	72	9	6.0
	^C1	32	Bio-NT	0.9	MF	LS	10	86	4	5.3
	^C2	59	Bio-NT	0.4	MF	S	3	95	2	5.2
	^C3	95	Bio-NT	.	.	S	3	94	3	5.1
	^C4	200+	Bio-NT	.	.	SL	16	80	4	4.9

*MF = Moderately Few Roots or between 0.2 and 1 per unit area.

**VF = Very Few Roots or <0.2 per unit area.

***Common Roots or between 1 and 5 per unit area.

Table G-1 Cont'd – Acid extractable nutrients and total carbon and nitrogen in all pedons described at the CWRP over the summer of 2006.

Plot ID	P	K	Ca	Mg	Zn	Mn	Cu	Fe	B	C	N
	Acid Extractable (mg/kg)									Total %	
101-4	71	118	3469	129	8.4	10.4	3.8	45	1	0.8	0.1
	5	42	485	69	2.0	2.4	7.4	11	0	0.1	0.1
	2	56	426	101	0.6	7.2	0.7	13	0	0.2	0.1
	4	16	136	30	0.6	3.7	1.6	6	0	0.1	0.0
	18	8	92	16	1.0	1.1	1.6	19	0	0.0	0.0
102-3	87	117	2715	103	7.8	11.3	8.4	50	1	0.8	0.4
	10	56	56	575	8.7	1.8	5.4	59	0	0.6	0.1
	2	38	226	49	0.9	2.1	3.4	8	0	0.1	0.0
	2	59	435	109	0.5	7.2	0.6	12	0	0.2	0.2
	2	11	89	20	0.4	1.2	0.9	5	0	0.0	0.5
	2	7	68	15	0.3	1.0	0.9	4	0	0.0	0.6
103-2	27	101	524	156	2.6	10.7	1.8	21	0	0.5	0.1
	16	58	472	115	4.9	8.9	10.3	70	0	0.4	0.1
	39	193	971	93	0.5	25.2	8.9	91	1	2.5	0.1
	3	37	151	31	0.4	3.1	1.1	13	0	0.0	0.6
	2	68	283	69	0.7	4.8	0.3	12	0	0.1	0.1
	2	20	92	18	1.7	2.5	0.9	6	0	0.0	0.0
104-5	23	139	768	157	1.7	15.0	3.2	49	0	1.0	0.1
	11	106	493	125	2.0	9.4	5.7	74	0	0.9	0.1
	2	40	296	85	1.5	5.5	7.5	12	0	0.1	0.1
	2	56	401	118	0.5	6.7	0.5	12	0	0.2	0.1
	2	8	72	19	0.3	1.1	0.8	4	0	0.0	0.0
201-2	22	99	984	192	1.5	18.5	2.8	44	0	0.6	0.1
	41	46	737	201	1.6	12.5	3.6	31	0	0.5	0.1
	11	43	397	115	2.1	8.0	7.0	22	0	0.3	0.1
	4	51	281	73	2.6	8.1	9.4	50	0	0.3	0.1
	2	11	83	23	0.5	1.3	1.1	9	0	0.0	0.1
	2	12	78	23	0.8	1.8	2.8	4	0	0.0	0.0
202-1	97	119	3046	100	8.0	11.5	2.9	40	1	1.0	0.1
	18	101	960	56	1.5	6.3	0.8	42	0	0.4	0.1
	6	62	386	67	1.9	5.4	5.7	26	0	0.4	0.1
	3	45	247	49	0.6	3.7	0.6	19	0	0.3	0.1
	2	11	69	15	0.4	0.9	0.5	5	0	0.0	0.0

Table G-1 Cont'd – Acid extractable nutrients and total carbon and nitrogen in all pedons described at the CWRF over the summer of 2006.

Plot ID	P	K	Ca	Mg	Zn	Mn	Cu	Fe	B	C	N
	Acid Extractable (mg/kg)									Total %	
203-3	24	139	565	184	0.8	8.2	1.3	10	0	0.4	0.1
	2	27	330	84	0.8	2.0	2.8	8	0	0.2	0.0
	2	23	223	55	0.8	2.9	2.3	10	0	3.0	0.1
	2	10	68	17	0.4	1.6	0.7	4	0	0.0	0.0
	2	33	207	49	0.3	3.1	0.3	8	0	0.1	0.1
	2	9	62	15	0.5	1.3	1.2	4	0	0.0	0.0
204-3	56	134	1626	84	3.3	5.8	3.2	57	0	0.6	0.1
	5	43	431	47	0.8	0.9	2.8	15	0	0.2	0.1
	3	31	212	43	1.2	3.3	4.5	13	0	0.2	0.1
	2	26	136	33	0.4	2.1	0.4	7	0	0.1	0.0
	2	17	90	19	0.9	4.7	2.8	4	0	0.0	0.0
	2	66	416	99	0.4	6.8	0.4	11	0	0.2	0.1
	2	12	77	19	0.7	1.0	2.7	3	0	0.0	0.0
301-3	81	145	2828	146	7.0	9.3	4.2	39	1	0.9	0.1
	7	47	692	75	2.1	2.9	8.2	15	0	0.2	0.0
	2	32	280	60	1.0	3.9	3.1	10	0	0.2	0.0
	2	13	96	23	1.1	2.6	4.6	5	0	0.0	0.0
	2	7	60	15	0.4	0.5	0.7	3	0	0.0	0.0
302-2	54	104	2978	101	5.8	7.2	3.3	33	1	0.8	0.1
	4	33	437	53	1.3	1.9	5.3	11	0	0.1	0.1
	2	25	214	40	0.9	1.9	3.3	9	0	0.1	0.1
	2	11	83	19	0.7	1.3	2.4	6	0	0.0	0.0
	2	11	71	17	0.6	0.7	1.9	4	0	0.0	0.0
303-2	25	133	867	185	3.3	14.7	12.2	71	0	0.8	0.1
	8	95	555	130	2.4	8.5	7.3	110	0	0.9	0.1
	2	33	201	51	2.0	4.4	7.5	11	0	0.1	0.0
	2	12	69	18	0.4	2.7	1.1	4	0	0.0	0.0
	2	8	56	15	0.4	1.7	0.5	6	0	0.0	0.0
304-1	22	97	643	137	0.9	6.8	1.6	14	0	0.4	0.1
	19	62	694	148	0.7	6.8	0.4	24	0	0.3	0.1
	2	34	251	66	0.4	5.7	0.2	10	0	0.1	0.1
	2	52	344	89	0.4	16.7	0.2	14	0	0.2	0.1
	2	10	72	18	0.3	3.1	0.6	3	0	0.0	0.0
401-5	17	96	529	142	1.2	6.0	2.8	12	0	0.3	0.1
	2	19	129	31	0.4	1.6	0.8	7	0	0.1	0.0
	2	10	91	23	0.4	0.9	0.9	2	0	0.0	0.0
	2	50	316	87	0.4	7.3	0.3	16	0	0.2	0.1

Table G-1 Cont'd – Acid extractable nutrients and total carbon and nitrogen in all pedons described at the CWRP over the summer of 2006.

Plot ID	P	K	Ca	Mg	Zn	Mn	Cu	Fe	B	C	N
	Acid Extractable (mg/kg)									Total %	
402-3	13	94	877	159	0.7	15.7	0.3	44	0	0.5	0.1
	3	43	537	133	0.6	8.6	0.3	29	0	0.3	0.1
	2	11	101	25	0.5	1.5	1.3	4	0	0.0	0.0
403-5	57	46	1257	91	3.0	7.1	2.5	68	0	0.4	0.1
	31	30	1125	80	2.2	6.8	2.4	75	0	0.3	0.1
	2	31	225	52	1.1	5.5	2.4	15	0	0.1	0.1
	2	33	186	49	1.4	4.7	3.9	15	0	0.1	0.1
404-1	39	93	1555	75	4.2	12.3	2.8	44	0	0.6	0.1
	8	32	664	43	1.4	3.9	2.7	26	0	0.2	0.1
	3	16	261	32	0.7	3.4	1.3	10	0	0.1	0.1
	2	7	81	15	0.3	0.9	0.5	4	0	0.0	0.0
	2	6	66	13	0.3	0.8	0.4	3	0	0.0	0.0
	2	22	123	33	0.6	3.2	1.5	8	0	0.1	0.1

Table G-2 – Depth to rooting, roots per horizon, soil texture, percent clay and soil pH per soil pit for the Compacted Area/external control taken over the summer of 2006.

Plot ID	Horizon	Depth to Lower Boundary (cm)	Roots/cm ²	NRCS Root Abund. Class	Texture	% Clay	% Sand	% Silt	pH
EC 5-2	^Ap	14	0.97	MF*	SL	16	73	11	7.0
	^Cd	27	0.27	MF	SL	12	75	13	7.2
	^C1	65	.	.	SCL	27	62	11	5.2
	^C2	150+	.	.	S	6	90	4	5.1
EC 7-2	^Ap	6	0.76	MF	SL	18	71	11	6.2
	^Cd	24	0.24	MF	SCL/SL	21	68	11	6.0
	^C1	67	.	.	SCL	29	59	12	4.9
	^C2	153	.	.	S	3	95	2	5.1
	^C3	200+	.	.	S	4	94	2	5.0
EC 11-2	^Ap	13	0.67	MF	SL	19	71	10	6.7
	^Cd	41	0.19	VF**	SCL	32	60	8	4.9
	^C1	67	0.05	VF	SL	15	76	9	4.8
	^C2	92	.	.	S	2	96	2	4.9
	^C3	200+	.	.	SL/LS	11	81	8	5.1
EC 12-2	^Ap	15	0.51	MF	SL	17	76	7	7.2
	^C1	53	0.07	VF	S	3	94	3	4.7
	2^C2	62	.	.	CL/SC	37	44	19	4.9
	3^C3	150+	.	.	S	5	89	6	5.0

*MF = Moderately Few Roots or between 0.2 and 1 per unit area.

**VF = Very Few Roots or < 0.2 per unit area.

Table G-2 Cont'd – Acid extractable nutrients and total carbon and nitrogen in all pedons described at the CWRF over the summer of 2006.

Plot ID	P	K	Ca	Mg	Zn	Mn	Cu	Fe	B	C	N
	Acid Extractable (mg/kg)									Total %	
EC 5-2	17	100	539	137	0.7	8.3	1.2	16	0	0.5	0.1
	7	69	528	76	1.1	6.1	1.7	19	0	0.1	0.4
	2	44	342	79	0.8	4.5	2.6	10	0	0.2	0.1
	2	16	103	25	0.4	1.8	1.1	5	0	0.0	0.0
EC 7-2	13	131	375	95	0.8	6.5	1.0	12	0	0.1	0.6
	4	66	435	99	0.8	5.8	1.6	16	0	0.1	0.3
	2	40	270	69	0.9	7.1	2.6	10	0	0.1	0.1
	2	10	75	20	0.4	1.5	0.9	3	0	0.0	0.0
	2	11	68	18	0.5	1.8	1.1	4	0	0.0	0.0
EC 11-2	12	99	395	103	0.7	5.5	1.2	15	0	0.4	0.1
	2	45	260	68	1.0	6.6	2.7	12	0	0.2	0.1
	2	28	177	47	0.8	3.7	2.5	7	0	0.1	0.1
	2	9	67	17	0.4	2.1	0.5	4	0	0.0	0.0
	2	22	115	30	0.6	4.6	1.8	7	0	0.1	0.1
EC 12-2	4	70	340	83	0.4	3.0	0.7	10	0	0.3	0.1
	2	11	75	16	0.3	0.5	0.5	2	0	0.0	0.0
	2	58	332	88	1.9	6.6	5.3	7	0	0.2	0.1
	2	15	111	25	0.6	1.6	1.7	3	0	0.0	0.0

Appendix H
Soil Descriptions for the Carraway-Winn
Reclamation Research Farm and Clarke Farm Soil
Pits (Summer 2006)

All profile descriptions were done between June and August of 2006.

Location: Pit 101-4 [Biosolids No Tillage] (Pit 1)

Vegetation: Soybeans;

Parent Material: Mineral sands mining tailings and slimes derived from stratified Upper Coastal Plain fluviomarine sediments and soils;

Physiography: Reconstructed ridge summit; Relief: 5 m;

Elevation: 65 m; Slope: 2 %;

Described by K. Meredith, Z. Orndorff, W. Daniels, and M. Nester, 06/29/06.

- ^Ap-- 0 – 6 cm; yellowish brown (10YR 5/6) sandy clay loam; weak fine to medium subangular blocky to massive structure; very friable, moderately few very fine and fine roots; gradual wavy boundary.
- ^C1-- 6 – 46 cm; strong brown (7.5YR 5/8) sandy clay loam; weak medium subangular blocky to massive structure, friable, moderately few fine to very fine roots; clear wavy boundary.
- ^C2-- 46 – 68 cm; yellowish red (5YR 5/6) clay with common, coarse, prominent dark yellowish brown (10YR 4/6) clay films; structureless, massive, extremely firm, moderately few very fine and fine roots along desiccation cracks only; abrupt smooth boundary.
- 2^C3-- 68 – 80 cm; light olive brown (2.5Y 5/6) sand; structureless, massive; very friable; very few fine and very fine roots; clear broken/irregular boundary.
- 2^C4-- 80 – 140+ cm; yellow (2.5Y 7/6) sand with common, coarse, faint, light olive brown (2.5Y 5/6) fragments of an A horizon; structureless, massive; very friable; 2 to 3 % gravels.

Notes:

- ^C1 layer: Few (< 2 %) light gray (2.5Y 6/1) sandy clay pockets of saprolitic material, few inclusions of angular strong brown (7.5YR 5/8) clay aggregates, an inclusion of a discontinuous, coarse, very dark brown (10YR 2/2) topsoil band occurs at 12 cm--banding is prominently located on West pit face. Where profile was described, soil is very dense until 22 cm. At other locations along the pit, a looser ^Ap horizon exists (up to 10 cm).
- ^C2 layer: Large vertical cracks prominent, cracks occur between 4 and 12 mm wide, roots follow these desiccation cracks only, few, (<2 %) fine, discrete, flakes of dark yellowish brown (10YR 4/6) woody debris.
- 2^C3 layer: Inclusions of 1 to 8 cm thick clay slime balls approximately 10 % of horizon. Slime balls are rounded masses of silty clay/clay material that are commonly formed from slimes, or the silty waste material, used in the backfilling of mining pits.
- 2^C4 layer: Exhibits deposition of tailings material that include; coarse sand/small gravel, clay slimes; and common, fine (less than 2 mm), discrete flakes of woody material. An intermittent layer of yellowish brown (10YR 5/8) clay slimes (2 to 4 cm thick) is evident. Tractor convolutions, or sinuous folding of materials that causes a rounded, sunken appearance within the profile, are evident within the layer.

Location: Pit 102-3 [Biosolids Conventional Tillage] (Pit 2)

Vegetation: Soybeans;

Parent Material: Mineral sands mining tailings and slimes derived from stratified Upper Coastal Plain fluviomarine sediments and soils;

Physiography: Reconstructed ridge summit; Relief: 5 m;

Elevation: 65 m; Slope: 2 %;

Described by K. Meredith, Z. Orndorff, W. Daniels, and M. Nester, 06/29/06.

- ^Ap1-- 0 – 10 cm; olive brown (2.5Y 4/4) sandy loam with few, medium, distinct brown (10YR 5/3) mottles, and common, fine to medium, distinct brown (10YR 5/3) sandy coatings on peds; common, medium, distinct, dark yellowish brown (10YR 4/6) small bodies, of clay, fine medium subangular blocky structure; friable; few to common very fine to fine roots; clear wavy boundary.
- ^Ap2-- 10 – 36 cm; strong brown (7.5YR 5/6) sandy loam; weak fine to medium subangular blocky structure; firm; moderately few very fine to fine roots; abrupt broken boundary.
- ^Bw-- 36 – 60 cm; light olive brown (2.5Y 5/6) loamy sand; weak very fine to fine subangular blocky structure; very firm; moderately few fine to very fine roots; 2 to 5 % gravels; abrupt irregular boundary.
- ^C1/Bw-- 60 – 82 cm; yellowish red (5YR 5/6) clay, with yellowish brown (10YR 4/6) loamy sand bodies, structureless, massive; extremely firm, many very fine and fine roots evident along desiccation cracks only; 5 % gravels evident in sand inclusions only; abrupt wavy boundary.
- 2^C2-- 82 – 120 cm; yellowish brown (10YR 6/8) sand with common, coarse, distinct, yellow (2.5Y 7/6) fragments of an A horizon; structureless, massive; very friable; few very fine roots and common fine roots; 5 % gravels; clear wavy boundary.
- 2^C3-- 120 – 140+ cm; pale yellow (2.5Y 7/3) sand; structureless, massive, very friable; 5 % gravels.

Notes:

- ^Ap1 layer: Layer is mixed with slime tailings.
- ^Ap2 layer: Dense layer with a thin (1 to 5 cm) intermittent red clay band occurring at 22 cm. Flecks/flakes of woody material evident.
- ^Bw layer: Flecks of woody material evident. Horizon does not occur along all pit faces. Along the South pit face, the ^Bw horizon tapers off. Common, mostly red clay slimes/balls apparent. Few discontinuous inclusions of densic materials. Two ripper traces noted within the ^Ab layer.
- ^C1/Bw layer: Few inclusions of loamy sand material. Vertical desiccation cracks --0.5 to 1 cm wide with sandy coatings along desiccation cracks. Offsetting/banding of variable colors and textures along clay ped faces-- red (harder, firmer and more brittle) clay with banding of brown (shinier, softer, smoother and stickier) clay. Few ped faces have a “rounded” morphology--i.e. tiny, rounded nodules, or rounded masses, with small perforations, or holes. Few, medium to coarse, prominent, dark yellowish brown (10YR 4/6) fragments of an A horizon.

- 2[^]C2 layer: One tractor convolution evident. Heavy mineral sand banding laterally within tractor convolution. Rooting occurred along upper 2 cm of horizon only.
- 2[^]C3 layer: Few flecks/flakes of woody material with common soft, smooth, brown clay material.

Additional Notes:

A very thin (< 2.54 cm) broken red clay band occurs between [^]Bw and 2[^]C1/Bw horizons. There is one very large clay inclusion (>30 cm) that extends beyond 140 cm. This inclusion reaches 15 cm wide in the 2[^]C2 and 2[^]C3 horizons. Along the West pit face, the boundary between the [^]Ap2 and the [^]Bw horizons is wavy and abrupt with two ripper traces. Along South pit face, the boundary between the [^]Ap2 and the [^]Bw horizons is wavier and mixed with depth.

Location: Pit 103-2 [Control] (Pit 3)

Vegetation: Soybeans;

Parent Material: Mineral sands mining tailings and slimes derived from stratified Upper Coastal Plain fluviomarine sediments and soils;

Physiography: Reconstructed ridge summit; Relief: 5 m;

Elevation: 65 m; Slope: 2 %;

Described by K. Meredith, Z. Orndorff W. Daniels and M. Nester, 06/30/06.

- [^]Ap-- 0 – 5 cm; olive brown (2.5Y 4/4) sandy loam; weak fine to medium granular structure; very friable; moderately few very fine roots; clear wavy boundary.
- [^]A-- 5 – 52 cm; olive brown (2.5Y 4/4) sandy loam with bodies of light gray (2.5Y 7/1) sandy clay loam and brownish yellow (10YR 6/8) sandy clay loam; structureless, massive; firm when moist, extremely hard when dry; moderately few very fine roots; clear wavy boundary.
- 2[^]C1-- 52 – 60 cm; black (2.5/N) sandy loam with few, coarse, prominent, light gray (2.5Y 7/1) fragments of an A horizon, weak very fine to fine subangular blocky structure, light gray fragments of an A horizon are structureless, massive; black material is firm, light gray material is extremely firm; moderately few very fine roots; abrupt smooth boundary.
- 3[^]C2-- 60 – 68 cm; brownish yellow (10YR 6/8) sand; structureless, massive; very friable; very few very fine roots; 1 to 2 % gravels; abrupt smooth boundary.
- 3[^]C3-- 68 – 86 cm; reddish yellow (5YR 6/8) sandy clay loam with light yellowish brown (2.5Y 6/4) clay bodies; structureless, massive; extremely firm; very few very fine roots -- limited to desiccation cracks only; 1 to 2 % gravels in sandy inclusions only; abrupt smooth boundary.
- 3[^]C4-- 86 – 130+ cm; brownish yellow (10YR 6/6) sand with common, medium, distinct, reddish yellow (7.5YR 6/8) fragments of a Bt horizon; structureless, massive; very friable; 1 % gravels.

Notes:

- [^]A layer: Common sandier material and topsoil colors evident. Sandy material has few, fine, loamy sand, light yellow lithochromic mottles. Few, inclusions of dense, compacted,

- 2[^]C1 layer: Gray material is structureless, massive--possible oxidized rhizospheres. Ash and charcoal rich woody debris apparent. Layer has densic properties but does not appear to be root limiting. Many roots located within black ash/woody material with few roots evident in denser areas.
- 3[^]C3 layer: Root limiting along red/strong brown clay. Rounded clay morphology evident, with small holes/perforations. Holes are not “channels” within the clay--possibly a result of how clay dried. Vertical cracking (0.25 to 0.5 cm) evident with many to common roots along desiccation cracks. Few, soft, light yellowish brown (2.5Y 6/4) clay films along clay ped faces.
- 3[^]C4 layer: Depositional bands of titanium and dark heavy mineral sands present.

Location: Pit 104-5 [Topsoil] (Pit 4)

Vegetation: Soybeans;

Parent Material: Mineral sands mining tailings and slimes derived from stratified Upper Coastal Plain fluviomarine sediments and soils;

Physiography: Reconstructed ridge summit; Relief: 5 m;

Elevation: 65 m; Slope: 2 %;

Described by K. Meredith, W. Daniels, P. Donovan and J. Burger, 07/03/06.

- [^]Ap1-- 0 – 7 cm; yellowish brown (10YR 5/4) sandy loam; moderate fine to medium granular structure; friable; very few very fine and fine roots; clear smooth boundary.
- [^]Ap2-- 7 – 26 cm; dark yellowish brown (10YR 3/4) sandy loam with common, medium, distinct, olive yellow (2.5Y 6/6), mottles; weak fine subangular blocky structure; firm; moderately few very fine to fine roots; abrupt smooth boundary.
- 2[^]Bw-- 26 – 50 cm; strong brown (7.5YR 5/6) sandy clay loam with faint reddish yellow (7.5YR 6/8) sandy coatings on ped faces; weak fine to medium subangular blocky structure; extremely firm; common very fine roots; clear wavy boundary.
- 2[^]C1-- 50 – 72 cm; strong brown (7.5YR 5/6) clay; structureless, massive; very friable; 1 to 2 % gravels; abrupt smooth boundary.
- 2[^]C2-- 72 – 130+ cm; olive yellow (2.5Y 6/6) sand; structureless, massive; very friable; 2 to 3 % gravels.

Notes:

- [^]Ap2 layer: Denser than [^]Ap1 horizon. Common (< 5 %), chunks of red (5YR 5/8) clay.
- 2[^]Bw layer: Two ripper traces evident. Sandy coatings on clay ped faces prominent.
- 2[^]C1 layer: Many inclusions of pale yellow (2.5Y 8/4) medium sand.
- 2[^]C2 layer: Exhibits deposition of tailings material, however, most likely a result of heavy mineral sand tailings settling during pit dewatering. Rounded pebbles occur at upper 10 cm.

Location: Pit 201-2 [Topsoil] (Pit 5)

Vegetation: Soybeans;

Parent Material: Stratified Mineral sands mining tailings and slimes derived from stratified Upper Coastal Plain fluviomarine sediments and soils;

Physiography: Reconstructed ridge summit; Relief: 5 m;

Elevation: 65 m; Slope: 2 %;

Described by K. Meredith, W. Daniels, P. Donovan and J. Burger, 07/03/06.

- ^Ap1-- 0 – 10 cm; yellowish brown (10YR 5/6), sandy loam with common, medium, prominent, reddish yellow (5YR 5/6) clay bodies, and many, medium, distinct, olive brown (2.5Y 4/4) sandy loam; bodies; weak coarse and medium granular structure; very friable; moderately few very fine roots; clear smooth boundary.
- ^Ap2-- 10 – 19 cm; strong brown (7.5YR 5/6) sandy loam with common, coarse, distinct, yellowish brown (10YR 5/6) bodies; weak fine to medium subangular blocky structure; firm; very few very fine to fine roots; clear smooth boundary.
- ^Abd1-- 19 – 30 cm; strong brown (7.5YR 5/6) sandy loam with common, medium, yellowish red (5YR 5/6) and common, medium, distinct, grayish brown (10YR 5/2) topsoil bodies; structureless, massive; firm; clear wavy boundary.
- ^Abd2-- 30 – 59 cm; yellowish brown (10YR 5/6) sandy loam with common, medium, olive brown (2.5Y 4/3) bodies with few, coarse, distinct, strong brown (7.5YR 5/8) clay bodies; structureless, massive; very firm; abrupt wavy boundary.
- 2^C1-- 59 – 90 cm; variegated brownish yellow (10YR 6/8) and yellow (10YR 7/6), and yellowish red (5YR 5/8) sand; structureless, massive; very friable; abrupt smooth boundary.
- 2^C2-- 90 – 130+ cm; strong brown (7.5YR 5/8) sand with alternating yellowish brown (10YR 5/8) and yellowish red (5YR 5/8) strata; structureless, massive; very friable.

Notes:

- ^Ap1 layer: Few (<2 %) woody material evident.
- ^Ap2 layer: Few, (<1 %) dark-colored ash material evident.
- ^Abd1 layer: Dense layer--rooting evident along desiccation cracks and ped faces along Southern pit face only. Few, inclusions of dark-colored ash material.
- ^Abd2 layer: Dense layer--rooting evident along ped faces and desiccation cracks only. A thin clay band occurs between 43 and 46 cm along West pit face only. Olive brown (2.5Y 4/4) banding occurs along West pit face--possible topsoil mixed within horizon. Few, dark gray (5YR 4/1) and common dark gray (7.5YR 4/1) lithochromic mottles evident. Horizon has a smeared/layered with topsoil compacted into it.
- 2^C1 layer: Thin (2 cm) red clay banding covers whole pit. Few, flecks/flakes of very dark gray (2.5Y 3/1) ash material. Ash material is more prominent above red clay strata. Few, coarse, white fine sand fragments evident.
- 2^C2 layer: Strata of smooth, soft, strong brown clay with fragments and strata of yellowish brown (10YR 5/8) sand. Redder color possibly a result of clay leaching.

Location: Pit 202-1 [Biosolids No Tillage] (Pit 6)

Vegetation: Soybeans;

Parent Material: Mineral sands mining tailings and slimes derived from stratified Upper Coastal Plain fluviomarine sediments and soils;

Physiography: Reconstructed ridge summit; Relief: 5 m;

Elevation: 65 m; Slope: 2 %;

Described by K. Meredith, P. Donovan, and J. Burger, 07/03/06.

- ^Ap1-- 0 – 7 cm; dark yellowish brown (10YR 4/6) sandy loam; weak medium granular structure; very friable; moderately few very fine and fine roots evident; clear smooth boundary.
- ^Ap2-- 7 – 25 cm; strong brown (7.5YR 5/8) sandy loam with common, coarse, distinct, yellowish brown (10YR 5/6) topsoil bodies, and common, medium, distinct, yellowish red (5YR 5/6) sandy loam bodies; weak medium subangular blocky structure; friable; very few fine to very fine roots; clear wavy boundary.
- 2^Bwu-- 25 – 61 cm; dark yellowish brown (10YR 4/6) sandy loam with common, medium, faint, dark grayish brown (10YR 4/2) fragments of an A horizon and common, medium, distinct, strong brown (7.5YR 5/8) fragments of a Bt horizon, weak medium subangular blocky structure; firm; very few fine to very fine roots; wavy smooth boundary.
- 3^BC-- 61 – 101 cm; variegated strong brown (7.5YR 5/8), yellowish red (5YR 5/8) and brown (10YR 4/3) sandy loam, with common, medium, prominent, gray (10YR 6/1) fragments of an A horizon; structureless, massive; friable; very few; less than 1 % gravels; abrupt smooth boundary.
- 3^C-- 101 – 130+ cm; strong brown (7.5YR 5/8) sand with many, faint reddish yellow (7.5YR 6/8) fragments of a Bt horizon; structureless, massive; very friable.

Notes:

- ^Ap1 layer: A mixture of gray clay bodies, sand and a few (< 2 %) woody debris.
- ^Ap2 layer: Dense layer with common (4-5 %) large, red, hard clay evident. Few nodules of woody debris and few (< 1 %) small pockets of light olive brown (2.5Y 5/6) topsoil material.
- 2^Bwu layer: Layer is as a mixture of topsoil with common (10 %) coarse to very coarse (2 to 5 cm) woody debris. Very dense layer. Small (< 1.5 cm) pieces of plastic sheeting evident towards border of ^Bwu and ^BC horizons--could account for wavy boundary.
- 3^BC layer: In the lower 10 cm of the horizon, a strong zone of brown (10YR 4/3) and gray (7.5YR 5/1) clay banding with yellow sand banding prominent. Clay varies in size from 10 cm and tapers to 5 cm. Common (< 3%) woody debris and nodules apparent. Layer is dense.
- 3^C layer: Heavy mineral sands banding--tailings deposition of tailings material. Clay leaching evident with very thin (< 0.5 cm), soft, brown clay. Horizon is not fully dewatered.

Additional Notes:

Pit location was 5 to 10 feet off plot center.

Location: Pit 203-3 [Control] (Pit 7)

Vegetation: Soybeans;

Parent Material: Mineral sands mining tailings and slimes derived from stratified Upper Coastal Plain fluviomarine sediments and soils;

Physiography: Reconstructed ridge summit; Relief: 5 m;

Elevation: 65 m; Slope: 2 %;

Described by K. Meredith, W. Daniels, P. Donovan and J. Burger, 07/04/06.

- ^Ap-- 0 – 7 cm; yellowish red (5YR 5/8) sandy clay loam with yellowish red (5YR 4/6) and reddish yellow (7.5YR 7/6), and many, medium prominent, light gray (7.5YR 7/1), bodies; moderate medium granular structure; friable; moderately few very fine roots; clear smooth boundary.
- ^Bw-- 7 – 30 cm; yellowish red (5YR 5/8), sandy loam with few, fine, distinct, light gray (7.5YR 7/1) fragments of an A horizon; weak fine to medium subangular blocky structure; friable; moderately few very fine to fine roots; gradual wavy boundary.
- ^Cd-- 30 – 59 cm; strong brown (7.5YR 5/8), sandy loam with many, medium, prominent, dark grayish brown (10YR 4/2) and few, fine, distinct, light gray (7.5YR 7/1) fragments of an A horizon; weak medium subangular blocky structure; sandy material friable, clay slimes firm; very few very fine roots, less than 1 % cobbles; clear smooth boundary.
- 2^C1-- 59 – 81 cm; reddish yellow (7.5YR 6/8), sand with reddish yellow (7.5YR 7/8) and yellow (10YR 7/8) banding; structureless, massive; very friable; 1 % gravelly coarse fragments; gradual wavy boundary.
- 2^C2/C1-- 81 – 102 cm; reddish yellow (7.5YR 6/8), sandy clay loam with many, very coarse, distinct, yellowish red (5YR 5/8) clay slime fragments; strong brown (7.5YR 5/8) streaks, or thin bands along clay ped faces, structureless, massive; very friable in sand with extremely firm clay; 1 % gravelly coarse fragments; clear wavy boundary.
- 2^C3-- 102 – 130+ cm; yellowish brown (10YR 5/8), sand with many, distinct, very pale brown (10YR 8/4), bodies; structureless, massive; very friable.

Notes:

- ^Bw layer: Few, coarse (< 1 cm) chunks of woody material evident.
- ^Cd layer: Color is variegated as a mixture of buried dark grayish brown (10YR 4/2) topsoil material and chunks of light gray clay slime fragments. Layer is dense--exhibits densic properties (root limiting, etc.). Woody debris and dead roots evident.
- 2^C1 layer: Heavy mineral sand banding with thin bands of white, tan, and yellow sand evident. Redder colors prominent at upper 5 cm of horizon. Few, dark, flecks/flakes of woody material and very few, light brown, smooth clay aggregates evident throughout layer.
- 2^C2/C1 layer: Clay shrink/swelled and sand filled in desiccation cracks. Clay is hard, firm and dark red in color.
- 2^C3 layer: Light tan sand prominent within upper 10 of horizon with few brown, smooth and very few red clay aggregates prominent at bottom 10 cm of horizon.

Location: Pit 204-3 [Biosolids Conventional Tillage] (Pit 8)

Vegetation: Soybeans;

Parent Material: Mineral sands mining tailings and slimes derived from stratified Upper Coastal Plain fluviomarine sediments and soils;

Physiography: Reconstructed ridge summit; Relief: 5 m;

Elevation: 65 m; Slope: 2 %;

Described by K. Meredith, W. Daniels, P. Donovan and J. Burger, 07/04/06.

- ^Ap-- 0 – 9 cm; strong brown (7.5YR 5/6), sandy loam with few, coarse, distinct, dark grayish brown (10YR 4/2), bodies; moderate fine to medium granular structure; friable; moderately few very fine roots; clear smooth boundary.
- ^Bw1-- 9 – 34 cm; strong brown (7.5YR 5/6), sandy loam with common, very coarse, distinct, gray (7.5YR 6/1) common very coarse, distinct, gray (7.5YR 5/1), common, coarse, prominent, olive yellow (2.5Y 6/6), fragments of an A horizon and few, coarse, distinct, yellowish red (5YR 5/6), bodies; weak fine subangular to angular blocky structure; friable; moderately few very fine roots; clear wavy boundary.
- ^Bw2-- 34 – 58 cm; strong brown (7.5YR 5/6), sandy loam with common, very coarse, prominent, light brownish gray (10YR 6/2), common, very coarse, prominent, grayish brown (10YR 5/2), fragments of an A horizon, and common very coarse, distinct, yellowish red (5YR 5/6), and few, coarse, prominent, olive yellow (2.5Y 6/6), bodies; weak medium angular blocky structure; friable; moderately few fine roots; abrupt smooth boundary.
- ^C1-- 58 – 69 cm; reddish yellow (7.5YR 6/8), sandy loam with common, extremely coarse, distinct, strong brown (7.5YR 5/6), and common, medium, distinct, brownish yellow (10YR 6/8) streaks and bodies; friable; structureless, massive; moderately few fine roots; 1 % gravelly coarse fragments; abrupt smooth boundary.
- 2^C2-- 69 – 92 cm; brownish yellow (10YR 6/8), sand with common, coarse, distinct, strong brown (7.5YR 5/6) banding, and common, coarse, distinct, reddish yellow (7.5YR 6/8) clay slime bodies; structureless, massive; very friable; 1 to 2 % gravelly coarse fragments; abrupt wavy boundary.
- 2^C3-- 92 – 104 cm; yellowish red (5YR 5/8), clay with common, coarse, distinct, reddish yellow (7.5YR 6/8), bodies; structureless, massive; firm; abrupt smooth boundary.
- 2^C4-- 104 – 130+ cm; reddish yellow (7.5YR 6/8), sand with common, coarse, faint, reddish yellow (7.5YR 7/8), bands; structureless, massive; very friable; less than 5 % gravelly rounded river cobbles.

Notes:

- ^Bw1 layer: Coarse, woody, material prominent throughout horizon.
- ^Bw2 layer: Large, pockets of topsoil-colored material with very few patches of red, smooth clay.
- ^C1 layer: Thin horizon, with few pockets of smooth, brown, clay.
- ^C2 layer: Few, fine, flakes of woody debris evident. A thin (2 to 5 cm), intermittent soft, brown, clay band occurs at 78 cm.
- 2^C3 layer: Clay is two colors; red, hard, firm, brittle, to strong brown (7.5YR 5/8), soft, smooth, silty clay. Layer is not fully dewatered.

- 3^C4 layer: Few, fine, flakes of woody material and bright red, and light yellow sand banding near upper boundary. Overall, sand is moist and layer is not fully dewatered.

Location: Pit 301-3 [Biosolids No Tillage] (Pit 9)

Vegetation: Soybeans;

Parent Material: Mineral sands mining tailings and slimes derived from stratified Upper Coastal Plain fluviomarine sediments and soils;

Physiography: Reconstructed ridge summit; Relief: 5 m;

Elevation: 65 m; Slope: 2 %;

Described by K. Meredith, W. Daniels, P. Donovan and J. Burger, 07/04/06.

- ^Ap-- 0 – 10 cm; strong brown (7.5YR 5/6) sandy clay loam; weak fine to medium granular and fine angular blocky structure; friable; moderately few fine to very fine roots; clear smooth boundary.
- ^Bw1-- 10 – 20 cm; strong brown (7.5YR 5/6) sandy clay loam with common, coarse, faint, strong brown (7.5YR 5/6) clay slime fragments; few, coarse, distinct, brown (7.5YR 5/2), and light yellowish brown (10YR 6/4) fragments of an A horizon; weak medium subangular blocky structure; friable, firm in places; moderately few very fine roots; clear smooth boundary.
- ^Bw2-- 20 – 64 cm; strong brown (7.5YR 5/6) sandy clay loam with common, medium, distinct, strong brown (7.5YR 5/8) bodies; few, coarse, distinct, yellowish red (5YR 5/6) bodies; few, medium, distinct, gray (7.5YR 6/1) bodies; common coarse to extremely coarse, prominent, light brownish gray (10YR 6/2), and few, medium, distinct, brownish yellow (10YR 6/6) bodies; moderate to weak medium subangular blocky structure; friable; moderately few to common roots in the upper horizon and fewer roots evident in lower half of horizon; less than 1 % gravelly rock fragments; abrupt smooth boundary.
- ^C1-- 64 – 97 cm; reddish yellow (7.5YR 6/8) sandy loam to loamy sand with common, coarse, faint strong brown (7.5YR 5/8) and coarse, distinct, yellowish red (5YR 5/6), clay banding; structureless, massive; very friable; less than 2 % gravelly coarse fragments; abrupt smooth boundary.
- ^C2-- 97 – 130+ cm; yellowish red (5YR 5/8), medium sand; structureless, massive; very friable; less than 2 % gravelly coarse fragments.

Notes:

- ^Bw1 layer: Dense layer--possible traffic pan.
- ^Bw2 layer: Few, soft, brown, clay aggregates and chunks of red, hard, clay evident. Common, flecks/flakes of woody material prominent throughout horizon.
- ^C1 layer: A thin (2 to 5 cm) layer of red clay occurs between 87 and 92 cm.
- ^C2 layer: Red, coarse, medium sand with flecks of woody debris and heavy mineral sand banding evident.

Location: Pit 302-3 [Biosolids Conventional Tillage] (Pit 10)

Vegetation: Soybeans;

Parent Material: Mineral sands mining tailings and slimes derived from stratified Upper Coastal Plain fluviomarine sediments and soils;

Physiography: Reconstructed ridge summit; Relief: 5 m;

Elevation: 65 m; Slope: 2 %;

Described by K. Meredith 07/04/06.

- ^Ap-- 0 – 12 cm; strong brown (7.5YR 5/6) sandy clay loam with common, coarse, distinct, brownish yellow (10YR 6/6) mottles; weak fine subangular blocky structure; friable; moderately few very fine roots; clear smooth boundary.
- ^Bw1-- 12 – 44 cm; strong brown (7.5YR 5/6) sandy clay loam with few, very coarse, faint, strong brown (7.5YR 5/6) and few, coarse, distinct, gray (7.5YR 6/1) clay slime fragments and common, coarse, distinct, strong brown (7.5YR 5/8) sandy bodies; weak to moderate fine subangular blocky to massive structure; friable; moderately few very fine rooting; clear smooth boundary.
- ^Bw2-- 44 – 73 cm; strong brown (7.5YR 5/6), sandy loam with common, coarse, faint, strong brown (7.5YR 5/6), few, very coarse, distinct brown (7.5YR 5/2), few, coarse, distinct, yellowish red (5YR 5/6), and common, coarse, distinct, brownish yellow (10YR 6/6), fragments of a diagnostic horizon; weak fine to medium subangular blocky to massive structure; friable (sandy loam) to firm (clay pockets); moderately few very fine and fine roots; abrupt smooth boundary.
- ^C1-- 73 – 104 cm; olive yellow (2.5Y 6/6), sand with common, distinct pale yellow (2.5Y 7/4), sand banding, common, distinct, very dark gray (2.5Y 3/1) sandy clay, common, very coarse, prominent, strong brown (7.5YR 5/6), red clay, and common, prominent, reddish yellow (7.5YR 6/8), sand banding; structureless, massive; very friable; less than 3 % gravelly coarse fragments; clear smooth boundary.
- ^C2-- 104 – 120+ cm; strong brown (7.5YR 5/6), sand with many, prominent, pale yellow (2.5Y 7/4), and many, prominent, brownish yellow (10YR 6/8) bands; structureless, massive; very friable.

Notes:

- ^Ap layer: Dark, woody debris evident.
- ^Bw2 layer: Roots concentrated along West pit face only. Large, red, clay bricks--up to 10 cm evident. Few, coarse, chunks of woody material with common inclusions of topsoil-colored material prominent throughout the horizon.
- ^C1 layer: A thin (< 3 cm) band of red clay occurs between 91 and 94 cm. A thin (1 to 2 cm) band of light/leached sand occurs directly below thin clay band. Some banding of very coarse, charcoal-colored, woody debris tapers off toward left side of West pit face. Overall, layer is damp.
- ^C2 layer: Deposition of tailings material, with few flakes of woody material. Sand is multi-colored, red and light/leached sand. Redder material constitutes 60 % of horizon and occurs primarily within upper 5 cm of horizon. Lighter, leached and yellow, brown sand banding constitutes 40 % of horizon, and occurs in lower 10 cm.

Location: Pit 303-2 [Topsoil] (Pit 11)

Vegetation: Soybeans;

Parent Material: Mineral sands mining tailings and slimes derived from stratified Upper Coastal Plain fluviomarine sediments and soils;

Physiography: Reconstructed ridge summit; Relief: 5 m;

Elevation: 65 m; Slope: 2 %;

Described by K. Meredith, Z. Orndorff and M. Nester, 07/05/06.

- ^Apu-- 0 – 12 cm; olive brown (2.5Y 4/4) sandy loam with common, coarse, prominent, strong brown (7.5YR 4/6) clay slime fragments; weak medium granular to moderate fine subangular blocky structure; very friable; moderately few to common very fine roots; clear smooth boundary.
- ^Ap-- 12 – 21 cm; olive brown (2.5Y 4/3) sandy clay loam with common, coarse, prominent, strong brown (7.5YR 4/6), and few, coarse, faint, olive brown (2.5Y 4/4) clay slime fragments; weak fine to medium subangular blocky structure; firm to very firm in places; moderately few very fine to fine rooting; abrupt smooth boundary.
- ^Bw-- 21 – 70 cm; strong brown (7.5YR 4/6) loamy sand with common, coarse, prominent, olive brown (2.5Y 4/3), common, coarse, prominent, light olive brown (2.5Y 5/6) and common, coarse to very coarse, distinct, grayish brown (10YR 5/2) fragments of an A horizon; weak medium subangular blocky structure; firm; very few very fine roots; less than 2 to 3 % gravelly coarse fragments.
- ^C1-- 70 – 87 cm; strong brown (7.5YR 5/8) sand with strong brown (7.5YR 5/6) and brownish yellow (10YR 6/6) bodies; structureless, massive; very friable; 1 % gravelly coarse fragments; clear smooth boundary.
- ^C2-- 87 – 130+ cm; strong brown (7.5YR 5/8), sand with common, coarse, to very coarse, distinct brown (7.5YR 5/4), and few, coarse to very coarse, prominent, light olive brown (2.5Y 5/6) fragments of an A horizon; medium to structureless, massive; very friable; 20 to 25 % gravelly coarse fragments.

Notes:

- ^Apu layer: Few (<2 %), coarse (2 cm) chunks of woody material and very few (<2 %) red clay slime fragments evident. Small pieces of a plastic liner prominent on South pit face only.
- ^Ap layer: Very dense layer, denser than ^Ap, however, is not root limiting. Few, coarse (< 1 cm), few red clay slime fragments with common very coarse (2 to 4 cm) brown/yellow lithochromic mottles apparent. A thin (< 5 mm), discontinuous, dark band of woody material accumulated at base of horizon.
- ^Bw layer: Common (10 %) very coarse (2 to 4 cm), red clay slime fragments, common (10 %) coarse (< 2 cm), light gray sandy clay slime fragments, common (5 %), very coarse to extremely coarse, dark gray topsoil-colored fragments, and common (5 %) coarse (< 1 cm) yellow brown fragments of a diagnostic horizon evident. Common (5 %) coarse (< 2 cm) chunks of woody material prominent throughout horizon.
- ^C1 layer: Few (< 2%), very coarse, topsoil-colored fragments with common (10 %), very coarse, light tan/brown fragments evident. A thin (< 2 mm) band of dark decaying

woody material evident. Thin layers/bands of light-colored fine, sand located at the boundaries of ^C1 and ^C2, and ^C2 and ^C3.

- ^C2 layer: Common (< 20 %), smooth, brown, silty clay banding--clay slimes, prominent towards bottom of horizon. Silty, clay balls located in upper half of horizon. A thin, coarse, banding of gravelly coarse fragments (20 to 25 % or layer) evident towards bottom 10 cm of horizon. Common (5 to 7 %), light brown/tan coarse sandy fragments and patches with flecks of woody material. Overall texture is coarser than ^C2 horizon.

Location: Pit 304-1 [Control] (Pit 12)

Vegetation: Soybeans;

Parent Material: Mineral sands mining tailings and slimes derived from stratified Upper Coastal Plain fluviomarine sediments and soils;

Physiography: Reconstructed ridge summit; Relief: 5 m;

Elevation: 65 m; Slope: 2 %;

Described by K. Meredith, Z. Orndorff, P. Donovan and W. T. Price 07/19/06.

- ^Ap-- 0 – 12 cm; yellowish red (5YR 4/6) sandy clay loam; weak to moderate fine granular to very fine subangular blocky structure; very friable; moderately few fine and very fine rooting, clear smooth boundary.
- ^A/C-- 12 – 43 cm; strong brown (7.5YR 5/6) sandy clay loam with many, medium, prominent, dark gray (7.5YR 4/1) bodies and common, coarse, distinct, yellowish red (5YR 4/6) fragments of a Bt horizon; moderate very fine to fine subangular blocky and massive structure; friable; few fine to very fine roots; abrupt smooth boundary.
- ^C1-- 43 – 78 cm; brownish yellow (10YR 6/8) sandy clay loam to sandy loam (sand filled in desiccated cracks) with many, coarse, distinct, strong brown (7.5YR 5/6) and common, coarse, distinct, olive yellow (2.5Y 6/6) bodies; structureless, massive; very friable to firm in places; very few to no fine to very fine roots; abrupt wavy boundary.
- 2^C2-- 78 – 100 cm; light yellowish brown (10YR 6/4) silty clay to clay with many, coarse, distinct, strong brown (7.5YR 5/6), and common, coarse, distinct, strong brown (7.5YR 6/6) fragments of a Bt horizon; structureless, massive; firm; abrupt smooth boundary.
- 3^C3-- 100 – 130+ cm; reddish yellow (7.5YR 6/8) sand; structureless, massive; very friable.

Notes:

- ^Ap layer: Common, medium, dark grayish brown (10YR 4/2) topsoil aggregates evident. Decaying woody debris and twigs constitute approximately 10 % of horizon.
- ^A/C layer: Clay is as a mixture of material with few, medium topsoil and red clay aggregates. Large pockets of coarse sand occur. Common, decaying woody material and twigs present. Roots are plastered along ped faces and desiccation cracks only. Possible fill material constitutes topsoil and mixed clay substratum.
- ^C1 layer: Sand and clay mixture. Texture varies along pit face--in some areas sand with overlying clay.
- 2^C2 layer: A mixture of brown, yellow and red sand with some heavy mineral sand banding.

Additional Notes:

Pit was moist throughout and saturated below 2[^]C2 horizon. Water slowly filled in bottom of pit while we were working; therefore we were unable to describe any hard or dense layers due to excessive moisture.

Location: Pit 401-5 [Control] (Pit 13)

Vegetation: Soybeans;

Parent Material: Mineral sands mining tailings and slimes derived from stratified Upper Coastal Plain fluviomarine sediments and soils;

Physiography: Reconstructed ridge summit; Relief: 5 m;

Elevation: 65 m; Slope: 2 %;

Described by K. Meredith and Z. Orndorff 07/19/06.

- [^]Ap-- 0 – 15 cm; strong brown (7.5YR 5/8) sandy loam with common, fine, distinct, dark brown (7.5YR 3/2) continuous bands of woody material; weak fine granular to moderate weak subangular blocky; very friable; moderately few fine to very fine roots; clear wavy boundary.
- [^]C1-- 15 – 44 cm; strong brown (7.5YR 5/8) sand with many, coarse, distinct, yellowish red (5YR 5/8), clay fragments; structureless, massive; very friable; very few very fine roots; less than 2 % gravelly coarse fragments; gradual broken boundary.
- [^]C2-- 44 – 72 cm; brownish yellow (10YR 6/8) sand with common, very coarse, faint, yellowish brown (10YR 5/8) fragments of a Bt horizon and very coarse, prominent, yellowish red (5YR 5/6) clay banding; structureless, massive; very friable; gradual wavy boundary.
- 2[^]C3-- 72 – 110+ cm; yellowish brown (10YR 5/8) silty clay to clay with many, fine, prominent, yellowish red (5YR 5/8) clay fragments and bands; structureless, massive; firm.

Notes:

- [^]Ap layer: Common (< 5 %), medium to coarse, clay nodules/aggregates evident. Aggregates are two colors--strong brown (7.5YR 5/8) and yellowish red (5YR 5/6). Few, light yellowish brown (2.5Y 5/6) clay aggregates located in other areas of the pit. Amount of fine material increased with depth. Where profile was described, west pit face, [^]Ap to [^]C1 boundary is clear, wavy. At other areas of the pit--from 10 to 40 cm--the zone is more mixed. Few, medium (0.5 cm), decaying twigs and woody material prevalent.
- [^]C1 layer: Few (< 2 %) flakes of woody debris evident.
- [^]C2 layer: A thin (2 to 4 cm) red clay band occurs in lower bottom 5 cm of horizon. At 54 cm depth, another thin (< 1 cm) discontinuous band occurs. Overall sand is coarser than [^]C1 horizon.
- 2[^]C3 layer: Alternating bands of thin (< 1 mm) clay and thin (< 1 mm) dark heavy mineral sands evident within horizon.

Location: Pit 402-3 [Topsoil] (Pit 14)

Vegetation: Soybeans;

Parent Material: Mineral sands mining tailings and slimes derived from stratified Upper Coastal Plain fluviomarine sediments and soils;

Physiography: Reconstructed ridge summit; Relief: 5 m;

Elevation: 65 m; Slope: 2 %;

Described by K. Meredith and Z. Orndorff 07/19/06.

- ^Ap-- 0 – 8 cm; olive brown (2.5Y 4/3) sandy loam with common, medium, prominent, strong brown (7.5YR 5/8) bodies; fine to medium weak medium granular structure; very friable; moderately few fine to very fine roots; clear smooth boundary.
- ^C1/C2-- 8 – 40 cm; olive brown (2.5Y 4/3) sandy loam with inclusions of red clay and many, extremely coarse, distinct, dark yellowish brown (10YR 4/6) sand fragments, and many, extremely coarse, prominent, strong brown (7.5YR 5/6) clay slime fragments; structureless, massive (clay inclusions); very friable (sand) to firm (clay) to friable (topsoil material); moderately few to many fine to very fine roots; abrupt smooth boundary.
- 2^Cu-- 40 – 100+ cm; light yellowish brown (2.5Y 6/4) sand with common, very coarse to extremely coarse, red clay banding; structureless, massive; very friable, clay banding firm.

Notes:

- ^Ap layer: Platy structure.
- ^C1/C2 layer: Layer is three different materials mixed together; yellow orange sand, red clay, and gray-brown topsoil. Along some parts of the pit, topsoil material is prominent and then less so in other areas.
- 2^Cu layer: Predominantly white-yellow sand with common, fine heavy mineral sand bands, and few coarse to extremely coarse red clay slime bands-depositional tailings material **Most of this layer slumped in while we were describing it.

Additional Notes:

This pit was saturated at 90 cm and very moist. A piece of a rubber hose was found in the upper portion of ^Cu horizon.

Location: Pit 403-5 [Biosolids Conventional Tillage] (Pit 15)

Vegetation: Soybeans;

Parent Material: Mineral sands mining tailings and slimes derived from stratified Upper Coastal Plain fluviomarine sediments and soils;

Physiography: Reconstructed ridge summit; Relief: 5 m;

Elevation: 65 m; Slope: 2 %;

Described by K. Meredith and M. Nester 08/09/06.

- ^Ap-- 0 – 10 cm; yellowish brown (10YR 5/8) sandy loam to loamy sand with few to common, medium to coarse, distinct, woody material accumulations; moderate

- medium granular to weak very fine subangular blocky structure; friable; moderately few very fine to fine roots; clear smooth boundary.
- ^A-- 10 – 23 cm; dark yellowish brown (10YR 4/6) loamy sand with common, coarse, distinct, woody debris accumulations and few, coarse, distinct, brownish yellow (10YR 6/8) bodies; weak very fine to fine subangular blocky structure; friable; moderately few to common fine to very fine rooting; clear wavy boundary.
- 2^C1-- 23 – 62 cm; strong brown (7.5YR 5/8) sandy clay loam with many, coarse, distinct, brownish yellow (10YR 6/8), many, coarse, distinct, brownish yellow (10YR 6/6), and few, coarse, prominent, light olive brown (2.5Y 5/6) clay slime fragments; weak fine subangular blocky to massive structure; friable; very few to many (in places) fine to very fine roots; clear wavy boundary.
- 2^C2-- 62 – 200+ cm; Yellowish brown (10YR 5/8) sandy clay loam to sandy loam with many, extremely coarse, distinct, light yellowish brown (10YR 6/4) clay aggregates, and many, coarse, prominent, dark grayish brown (10YR 4/2) heavy mineral sand bands, and many, coarse, prominent, yellowish red (5YR 5/6) clay aggregates; structureless, massive; clay is firm, sand is friable.

Notes:

- ^Ap layer: Slight accumulation (2 to 5 %) of woody material.
- ^A layer: Higher accumulation of woody debris than previous ^Ap layer. Is denser than ^Ap layer.
- 2^C1 layer: Many (35 %) red clay banding and clay aggregates evident. Clay aggregates are very coarse (up to 6 cm), red and brown. Matrix color is variegated and difficult to distinguish in certain areas. Roots are plastered along west pit wall in desiccation cracks and ped faces only.
- 2^C2 layer: Slumping of soil from bull dozers, or convolutions--large areas of sand incorporated within clay/sandy clay layer-evident. Few, black, heavy mineral sands prominent along west pit face-depositional tailings material. Variable types of clay--red, hard, clay and soft, silty, smooth, brown clay. Red clay is more prominent than brown. Clay accounts for 30 to 35 % of horizon with sandy material accounting for 40 %. The remaining material is a sand and clay mix.

Additional Notes:

Water accumulation from North pit face is evident in lower left corner. None of the ^Ap layers are very dense--only distinguished out two layers due to slight change in density and overall accumulation of woody debris.

Location: Pit 404-1 [Biosolids No Tillage] (Pit 16)

Vegetation: Soybeans;

Parent Material: Mineral sands mining tailings and slimes derived from stratified Upper Coastal Plain fluviomarine sediments and soils;

Physiography: Reconstructed ridge summit; Relief: 5 m;

Elevation: 65 m; Slope: 2 %;

Described by K. Meredith and M. Nester 08/09/06.

- ^Ap-- 0 – 11 cm; strong brown (7.5YR 5/8), sandy clay loam; moderate fine granular structure; very friable; moderately few fine to very fine roots; clear smooth boundary.
- ^Bw-- 11 – 22 cm; strong brown (7.5YR 5/6), sandy loam to sandy clay loam; weak to moderate medium subangular blocky structure; very firm to firm; very few common to many fine to very fine roots; clear smooth boundary.
- ^C1-- 22 – 32 cm; yellowish brown (10YR 5/8), sand with common, coarse, distinct, strong brown (7.5YR 5/8) bodies; moderate medium platy structure; firm to very firm consistence; moderately few fine to very fine roots; wavy smooth boundary.
- ^C2-- 32 – 59 cm; yellowish brown (10YR 5/8), fine sand with common, coarse, distinct, strong brown (7.5YR 5/8) common, coarse, distinct, brownish yellow (10YR 6/8), common, coarse, distinct, strong brown (7.5YR 5/8), and common, coarse, distinct, olive yellow (2.5Y 6/6) bodies; structureless, massive; very friable; moderately few fine to very fine roots; 1 % gravelly coarse fragments; clear abrupt boundary.
- ^C3-- 59 – 95 cm; brownish yellow (10YR 6/8), coarse sand with clay banding with common, coarse, distinct, strong brown (7.5YR 5/8) common, coarse, distinct, brown (10YR 4/3) bands and common, very coarse, distinct, very pale brown (10YR 7/4) banding; structureless, massive; very friable; less than 7 % gravelly coarse fragments; clear smooth boundary.
- ^C4 -- 95 – 200+ cm; brownish yellow (10YR 6/8), sandy loam; structureless, massive; firm to friable in places; less than 5 % gravelly coarse fragments.

Notes:

- ^Ap layer: Decaying, woody material evident throughout horizon. Layer is uncharacteristically loose--difficult to obtain bulk density samples.
- ^Bw layer: Few, coarse chunks of woody material evident. Overall, layer is denser layer than ^Ap.
- ^C1 layer: Layer is very dense in places--possible traffic pan. Layer is discontinuous and tapers off to a few cm on the right side of the West pit face. Roots are plastered along West pit face only.
- ^C2 layer: Accumulation of very coarse (5 cm) red clay aggregates.
- ^C3 layer: Overall color is variegated with light, fine, sand more prominent within upper 5 cm of horizon. Dark heavy mineral sand bands, and a thin, (1 to 2 cm) red clay band, located at 90 cm depth, evident from deposition of tailings material. HMS and clay banding are discontinuous and non-existent on left side of West pit face. Strong clay leaching evident--see redder sand color.

- ^C4 layer: Increase in clay content with depth, with redder clay accumulating at bottom and softer, strong brown, clay located at upper 5 cm of layer. Heavy mineral sand bands occur along West pit face only.

Location: Pit EC 5-2 [None—Adjacent to a Topsoil Plot] (Pit 17)

Vegetation: Soybeans;

Parent Material: Mineral sands mining tailings and slimes derived from stratified Upper Coastal Plain fluviomarine sediments and soils;

Physiography: Reconstructed ridge summit; Relief: 5 m;

Elevation: 65 m; Slope: 2 %;

Described by K. Meredith and M. Nester 08/09/06.

- ^Ap-- 0 – 14 cm; brownish yellow (10YR 4/6) sandy loam; moderate medium granular to weak subangular blocky; friable; moderately few to common fine to very fine roots; 1 % gravelly coarse fragments; clear smooth boundary.
- ^Cd-- 14 – 27 cm; dark yellowish brown (10YR 3/6) sandy loam with common, medium, distinct, dark grayish (10YR 4/2) bodies; moderate medium platy structure; friable; moderately few fine to very fine roots; clear smooth boundary.
- ^C1-- 27 – 65 cm; strong brown (7.5YR 4/6) sandy clay loam with few, fine, distinct, gray (10YR 5/1) fragments of an A horizon; structureless, massive; firm to extremely firm; abrupt smooth boundary.
- ^C2-- 65 – 150+ cm; reddish yellow (7.5YR 6/6) medium sand with common, coarse, distinct, yellow (10YR 7/6) bodies; structureless, massive; friable; less than 2 % coarse fragments.

Notes:

- ^Ap layer: Few chunks of woody material evident.
- ^Cd layer: Very dense layer--as noted platy structure. Much denser than ^Ap horizon. Very few, fine to medium, woody material nodules apparent.
- ^C1 layer: Very dense, very hard, brittle layer--as if harden clay texture. Few, coarse, light topsoil-colored nodules apparent.
- ^C2 layer: The ^C2 layer bands of clay, lighter sand and HMS from tailings deposition, clay is red and brittle, sand is medium, few patches of light brown smooth clay, general is reddish sand (most likely due to clay leaching).

Location: Pit EC 7-2 [None—Adjacent to a Control Plot] (Pit 18)

Vegetation: Soybeans;

Parent Material: Stratified Mineral sands mining tailings and slimes derived from stratified Upper Coastal Plain fluviomarine sediments and soils;

Physiography: Reconstructed ridge summit; Relief: 5 m;

Elevation: 65 m; Slope: 2 %;

Described by K. Meredith and M. Nester 08/09/06.

- ^Ap-- 0 – 6 cm; brown (7.5YR 5/4) sandy loam; weak very fine to fine subangular blocky to moderate medium granular structure; friable; moderately few fine to very fine roots; clear smooth boundary; less than 2 % gravelly coarse fragments.
- ^Cd-- 6 – 24 cm; strong brown (7.5YR 5/6) sandy loam to sandy clay loam with common, coarse to very coarse, distinct, dark yellowish brown (10YR 4/4) fragments of an A horizon; weak medium to coarse subangular blocky structure; very firm; moderately few fine to very fine roots.
- ^C1-- 24 – 67 cm; strong brown (7.5YR 5/6) sandy clay loam; structureless, massive; firm to extremely firm in places; moderately few fine to very fine roots; less than 3 % gravelly coarse fragments; abrupt smooth boundary.
- ^C2-- 67 – 153 cm; brownish yellow (10YR 6/8), sand with common, fine, faint, brownish yellow (10YR 6/6) common, fine, distinct, very dark grayish brown (10YR 3/2), and common, fine, prominent, pale yellow (2.5Y 7/3) bodies; structureless, massive; friable; abrupt smooth boundary.
- ^C3-- 153 – 200+ cm; strong brown (7.5YR 5/8) sand with common, fine to medium, distinct, brownish yellow (10YR 6/6), and common, medium, distinct, yellowish brown (10YR 5/8) bodies; structureless, massive; friable.

Notes:

- ^Ap layer: Few, small chunks and flakes of woody debris--most likely roots from previous row crops evident.
- ^Cd layer: Very dense layer with few roots. A thin (2 to 6 cm), discontinuous band of topsoil material occurs at 20 cm.
- ^C1 layer: Large increase in clay content towards bottom 10 cm of horizon.
- ^C2 layer: Is multicolored sands--variegated colors from deposition of tailings material; white, heavy mineral sand material--thin bands of brown, red, and yellow sands. Few, fine (< 1mm), smooth, silty, clay bands prominent.
- ^C3 layer: Very red sand with few heavy mineral sands banding from deposition of tailings material and light brown sand lithochromic mottles.

Additional Notes:

Pit slowly filled in with water, from lower left side of West pit face.

Location: Pit EC 11-2 [None—Adjacent to a Topsoil Plot] (Pit 19)

Vegetation: Soybeans;

Parent Material: Mineral sands mining tailings and slimes derived from stratified Upper Coastal Plain fluviomarine sediments and soils;

Physiography: Reconstructed ridge summit; Relief: 5 m;

Elevation: 65 m; Slope: 2 %;

Described by K. Meredith and M. Nester 08/10/06.

- ^Ap-- 0 – 13 cm; strong brown (7.5YR 5/6) sandy loam; weak fine granular to moderate medium subangular blocky structure; very friable; moderately few fine to very fine roots; gradual smooth boundary.
- ^Cd-- 13 – 41 cm; strong brown (7.5YR 5/8), sandy clay loam with an increase in clay towards bottom of horizon with common, medium to coarse, distinct, yellowish red (5YR 5/6) clay bodies; structureless, massive; firm; very few fine to very fine roots; abrupt smooth boundary.
- ^C1-- 41 – 67 cm; yellowish brown (10YR 5/8), sandy loam with common, coarse, faint, brownish yellow (10YR 6/8), bodies, and common, fine, faint, yellowish brown (10YR 5/8), common, fine, faint, brownish yellow (10YR 6/6) and common, fine, prominent, yellowish red (5YR 5/8) clay slime bodies, and common, fine, distinct, very dark grayish brown (10YR 3/2) heavy mineral sand strata; structureless, massive; clay is firm, sand is friable; very few fine to very fine roots at top of horizon only; abrupt wavy boundary.
- ^C2-- 67 – 92 cm; yellowish brown (10YR 5/8), sand with few, fine to medium, faint, brownish yellow (10YR 6/8) clay slime bodies, and many, fine, distinct, brown (10YR 4/3) heavy mineral sand strata; structureless, massive; friable; abrupt smooth boundary.
- ^C3-- 92 – 200+ cm; yellowish brown (10YR 5/8), sandy loam to loamy sand with common, coarse, distinct, dark brown (10YR 3/3) heavy mineral sand strata and common, coarse, distinct, brownish yellow (10YR 6/6) sand bodies; structureless, massive; firm.

Notes:

- ^Ap layer: Few, medium to coarse chunks of woody material prominent at upper 5 cm of horizon.
- ^Cd layer: Significant increase in clay especially towards bottom 10 cm of horizon--possible traffic pan. Layer is very dense--exhibits strong densic properties.
- ^C1 layer: Discontinuous band of medium sand--tapers off towards the right side of the West pit face. Sand is multicolored with redder material more prominent in the upper 10 cm and lighter tan material more prominent towards bottom-- red material most likely a result of clay leaching from ^C1 horizon. Overall texture varies between sand and clay due to clay slimes. Within the upper 4 cm of the horizon, texture is pure sand tailings and not a mixture of sandy clay.
- ^C2 layer: Layers of heavy mineral bands present from deposition of tailings material. Sand is predominately two colors--light tan and reddish brown with the redder color possibly due to clay leaching. Sand is coarser than sand found in ^C2 layer.

- ^C3 layer: Intermitted bands of soft, brown, clay material mixed together with bands of heavy mineral sands from deposition of tailings material. Increase in soft clay towards bottom of horizon. Sand inclusions are fine than sands found in ^C2 and ^C1 layers.

Location: Pit EC 12-2 [None—Adjacent to a Control Plot] (Pit 20)

Vegetation: Soybeans;

Parent Material: Mineral sands mining tailings and slimes derived from stratified Upper Coastal Plain fluviomarine sediments and soils;

Physiography: Reconstructed ridge summit; Relief: 5 m;

Elevation: 65 m; Slope: 2 %;

Described by K. Meredith and M. Nester 08/10/06.

- ^Ap-- 0 – 15 cm; strong brown (7.5YR 5/6) sandy loam; weak thin platy to weak fine granular structure, brittle; moderately few fine to very fine roots; clear smooth boundary.
- ^C1-- 15 – 53 cm; brownish yellow (10YR 6/8) fine sand, with common, coarse, faint, brownish yellow (10YR 6/6) sand bodies, and common, coarse to very coarse, brown (10YR 4/3) heavy mineral sand bands; structureless, massive; friable; very few fine to very fine roots; clear smooth boundary.
- 2^C2-- 53 – 62 cm; strong brown (7.5YR 5/6) clay loam to sandy clay loam with common, coarse, distinct, brownish yellow (10YR 6/8) sand bodies and common, coarse, distinct, yellowish red (5YR 5/6) clay aggregates; structureless, massive; firm in place, friable; clear smooth boundary.
- 2^C3-- 62 – 150+ cm; brownish yellow (10YR 6/6) sand with few, coarse, distinct, strong brown (7.5YR 5/6) clay slime fragments, common, fine, distinct, brown (10YR 5/3) heavy mineral sand bands, and common, medium to coarse, distinct, light yellowish brown (2.5Y 6/4) sand bodies; structureless, massive; friable.

Notes:

- ^Ap layer: Has a granular structure in the upper 3 to 4 cm, followed closely by a hard platy structure--possible traffic pan.
- ^C1 layer: Bands of heavy mineral sands evident from deposition of tailings material. HMS layers are flat and have not been altered/convoluted by bull dozers. Very few, small (< 2 cm) strong brown (7.5YR 5/8) clay aggregates. Leaching of 5Ap horizon evident in upper 2 to 5 cm.
- 2^C2 layer: Thin clay layer with few sand inclusions. Layer is discontinuous--occurs over West and North pit faces only. Overall texture is smooth, soft clay with few hard, dark red, brittle, clay nodules mixed in.
- 2^C3 layer: Bands of heavy mineral sands evident from deposition of tailings material. A thin, (< 2 cm) clay band occurs at 88 cm.

Additional Notes:

Pit filled with water at a slow rate.

VITA

A wonderful yet unplanned ‘bundle of joy,’ I, Kelly Robyn Meredith, was born in a small hospital in Warrenton, Virginia to a Mr. and Mrs. Billy and Betty Meredith. Irish/English/French and Native American ancestry, make up the bulk of my lineage. As a child, I grew up in rural Culpeper, Virginia. Over the years, I watched my rural hometown slowly grow more and more suburban thanks to Northern Virginia Sprawl. After graduating Culpeper County High School with an advanced degree, I set my sights on attending college. I fell in love with Virginia Polytechnic Institute and State University upon my first visit and decided to study, of all things, Mining engineering, during my Undergraduate tenure. After summer internships focusing on the various aspects of the mineral processing part of mining, I vowed to correct my mistake and set my sites on a more environment friendly area of research -- land reclamation. Considering that I was not yet ready to leave the beauty that is Virginia Tech, I decided to see what graduate opportunities the school had to offer. Here I met Dr. W. Lee Daniels, a prominent professor in Crop and Soils and Environmental Sciences. I was lucky enough to garner an assistantship with him, and after a summer internship at a prominent mining company coupled with excursions of soil sampling for Dr. Daniels, I was ready to begin my graduate career. Three years, one wonderful and encouraging boyfriend, a cast of incredibly supporting family and friends, and a Masters degree later, I am still searching for that one career opportunity that will not only allow me to preserve and help our Mother Earth, but will give me that feeling of a job well done!