

EFFICIENCY TEST OF THE DUST COLLECTOR
ON NO. 6 BOILER
IN THE V.P.I. POWER PLANT

by
James L. Truitt, Jr.
and
Richard H. Riel

Thesis submitted to the Graduate Faculty of the
Virginia Polytechnic Institute
in candidacy for the degree of
MASTER OF SCIENCE
in
Power and Fuel Engineering

APPROVED:

Director of Graduate Studies

Dean of School

APPROVED:

Head of Department

Chairman, Advisory Committee

May 31, 1951

Blacksburg, Virginia

TABLE OF CONTENTS

TITLE PAGE	1
TABLE OF CONTENTS	2
TABLE OF FIGURES	4
ACKNOWLEDGEMENTS	5
INTRODUCTION	6
REVIEW OF LITERATURE	8
THE INVESTIGATION	12
Object	12
Apparatus	14
<u>Cyclone type filter</u>	14
<u>Flue sampling nozzle</u>	14
<u>Orifice meter</u>	16
<u>Control valve</u>	16
<u>Suction</u>	16
<u>Pressure taps</u>	18
Method of Test	19
Procedure for Operating Samplers	22
Procedure for Seive Analysis	27
RESULTS	28
DISCUSSION OF RESULTS	45
BIBLIOGRAPHY	49
VITA	50
APPENDIX I	52

Sample Calculations	52
Apparatus Parts List	56
Recommendations for Refinement of Apparatus	57

4

TABLE OF FIGURES

Figure 1.	15
Arrangement of Aerotec tubes and metering orifice.	
Figure 2.	17
Sampling nozzle and pressure tube details.	
Figure 3.	20
Arrangement of Dust Collector and location of sampling cross-sections.	
Figure 4.	25
Inlet sampling cross-section and sampling points. Guage marks determine depth of probing tube in the flue.	
Figure 5.	25
Outlet sampling cross-section and position template. By moving point B, on the probing tube, to points 1', 2', 3', etc., the nozzle will locate at points 1, 2, 3, etc. Point A is the pivot point.	

ACKNOWLEDGEMENTS

The authors wish to give special acknowledgement to
and for their efforts in maintaining
constant boiler load for the duration of the test runs, and for the use
of data from tests run concurrently by them.

Sincere appreciation is also expressed to the members of the advisory committee, Professors J. Lucien Jones and C. Hardy Long, and Mr. R. K. Will for their kind advice and assistance.

The authors wish to thank and for their
kind assistance in the construction of the test apparatus.

Thanks is expressed to the Aerotec Company, Greenwich, Connecticut, for the loan of four Aerotec tubes, which formed a vital part of the test apparatus.

Blacksburg, Va.
May, 1951.

J. L. Truitt, Jr.
R. H. Riel

INTRODUCTION

In 1949 a new steam generating unit was installed in the V.P.I. Power Plant. The unit consists of an Edge Moor, two drum water cooled furnace equipped with a Detroit Roto-grate stoker. This unit was chosen because of its adaptability in burning a wide variety of coal, including semi-anthracite culm coal of which a large stock pile exists.

In order to obtain highest efficiency and minimum air pollution, dust collecting equipment of a standard design, manufactured by the Prat-Daniel Corporation of Greenwich, Connecticut, was installed. This unit is the Standard Type HC Thermix Tubular Dust Collector, employing the cyclone principle of separation. The design conditions for this unit were given as follows:

Performance:	Elevation 2100', bar. 27.6" Hg.
	<u>Maximum Net</u>
Steam, lb/hr:	30,000
Gas flow, lb/hr:	83,000
Gas temperature, °F:	450
Draft, furnace, boiler, air heater, ducts and dampers, "wg:	3.00
Draft, collector, "wg:	2.20
Total draft required, "wg:	5.20
Collection efficiency:	In accordance with Curve G-14-R.

The cyclone principle of operation utilizes the centrifugal forces obtained by directing the dust laden gases tangentially into a tube. The heavier dust particles will move to the outside of the induced cyclone and be separated. The quantity of flow entering the tube will determine the centrifugal force and hence the force of separation, $C.F. = mv^2/r$.

"This fact has considerable importance in the collection of flyash from

boiler flue gas, due to the fact that there is usually considerable variation in boiler rating and the collecting apparatus should be designed for maximum rating which would produce maximum dust loading in the gas and maximum gas quantity. If the boiler should vary between 300% and 100% minimum rating, the collection efficiency would drop accordingly."¹ Furthermore, collection efficiency is also affected materially by temperature since according to Stokes' Law, the settling force of a particle in a medium is directly proportional to the coefficient of viscosity of a medium (among other things). In this case the medium, flue gas, increases in viscosity with increasing temperature. Therefore, the centrifugal force exerted upon a particle in a cyclone must be greater at higher temperature than at lower temperature to carry it to the wall of the cyclone. Roughly, the efficiency drops two percent for each 100 °F rise above design temperature, with a corresponding increase in efficiency for temperatures below design conditions.²

It is therefore the purpose of this investigation to observe what factors affect the efficiency of the dust collector, and hence the overall efficiency of the steam generating unit.

1,2. L. C. Whiton, Jr., "Research on Cyclone Dust Collectors," Rock Products, February 27, 1932.

REVIEW OF LITERATURE

Because of increased industrialization, the subject of atmospheric pollution has assumed considerable importance in recent years. High among the chief causes of pollution, is the emission of flyash from the stacks of industrial plants with coal burning equipment. Since so many districts have now established smoke control ordinances, it has been necessary for plant operators to consider devices for the elimination of flyash in stack gases.

The Standard Type HC Tubular Dust Collector is designed for plants which, because of their location, do not require an extremely high dust collection efficiency, yet desire a relatively high degree of removal for the welfare of their workers. It has proved especially satisfactory for spreader stoker fired units, where the dust usually contains a greater amount of material above 10 microns. Guaranteed efficiency is 89 percent for particles over 20 microns, with 96 percent for 40 microns and above.³ However, since the actual size of dust particles in the flue gas at the V.P.I. Power Plant is not known, the actual efficiency of the collector is uncertain. It is therefore necessary to devise some means of removing a representative flyash sample from the gas stream for analysis.

The various devices for stack sampling may be divided into two groups,

3. Prat-Daniel Corporation, "Prat-Daniel Tubular Dust Collectors Valmont Type S and Standard Type HC," Catalog No. 250 S.

those having low sampling rates, three cubic feet per minute or below, and those which permit higher sampling. Tests⁴ of various methods led to the selection of the cyclone as the most desirable for general purpose testing, "because the ideal sampling method should have a high sampling rate in order to allow the withdrawal of representative samples from the flue gas stream." For maximum flow at design conditions its efficiency may be as high as 98 percent. Although the bag filter and the electrostatic precipitator are slightly more efficient, the advantages of the cyclone more than compensate for this small drawback. At any flow the pressure drop is lower than all other methods, with the exception of the electrostatic precipitator. The cyclone requires little or no time to be prepared for use, and the sample is collected dry, ready for immediate analysis. Care must be taken however, to properly insulate the device if the gas temperature approaches the dew point, as the condensation of moisture may present sampling difficulties. Cyclones have no upper temperature limitations, and are especially adapted to heavy dust concentrations at high boiler ratings. At very low concentrations, an impinger or an electrostatic precipitator can be used for check purposes.

Various types of bag filters have been used for sampling, all of which have efficiencies approaching 100 percent. Their pressure drop however, increases as the square of the sampling rate, and is nearly

4. A. C. Stern, "The Measurement and Properties of Cinders and Fly-Ash," Combustion, vol. 4, June-July, 1933, pp 35-37.

three times that of a cyclone for equivalent gas flow. In addition, they tend to clog up rapidly in use, causing fluctuations in the sampling rate. Cotton bags are limited to temperatures below 200 °F, and also cannot be used below the dew point of the flue gas. No satisfactory method has been found for weighing the bags accurately or for removing the contents for independent weighing. The most favorable bag filter technique to date consists of using a bag with its bottom unsewn and fastened to the top of a glass beaker, which may be removed for weighing. Bags can be used repeatedly if cleaned after each test.

The electrostatic precipitator tube has the lowest pressure drop for any given gas flow. There is little or no variation in pressure drop during the course of a run, making constant sampling rates possible. Measurements can be made of quantities less than the weighing error of bag or paper filters, and the complete sample reclaimed for laboratory analysis. Very little time for preparation is required, and they may be used any number of times. There are two major disadvantages in the use of the electric precipitator. A source of high potential alternating current is required, and a pre-cleaner must be used if the dust contains any heavy cinder particles, as they may be blown through the precipitator due to their size and inertia.⁵

Consideration of the various separating devices finally led to the selection of the Aerotec tube, manufactured by the Aerotec Company, and

5. Stern, loc. cit.

developed by the Prat-Daniel Corporation. Dust is separated by the principle of centrifugal force, similar to the tubular dust collector being tested. It is a small, compact unit, capable of operating at temperatures as high as 800 °F with a sampling rate of 35 cubic feet per minute. The manufacturers claim an efficiency of 100 percent for all particles over 20 microns, and 92 percent for all dusts over 10 microns. By using two of these tubes in series, sufficient sampling accuracy should be obtained to produce satisfactory test results.⁶

6. Prat-Daniel Corporation, "Thermix Products," Catalog No. 200, p 16.

THE INVESTIGATION

Object

The primary object of this investigation was to determine the overall efficiency of the Standard Type HC Thermix Tubular Dust Collector, as used on the No. 6 boiler in the V.P.I. Power Plant. The efficiency, or ratio of dust collected to total gas loading, was determined for various loads with and without reinjection of collected flyash.

It was believed that sufficient data could be obtained at loads of 25, 35, 45, and 55 thousand lb of steam per hr to fulfill the purpose of the test. Every effort was made to operate the boiler at maximum efficiency at each load. Results include curves of boiler load vs. collection efficiency.

In order to arrive at the above objectives, the following experimental information was required:

- 1.) Static pressure at inlet and outlet sampling cross sections.
- 2.) Velocity at inlet and outlet of the collector.
- 3.) Flue gas temperatures at inlet and outlet.
- 4.) Gas flow.
- 5.) Gas loading at inlet and outlet of the collector.
- 6.) Draft loss through the collector.

Wherever possible the suggestions of the A.S.M.E. Test Code were followed. Two tests were made at each load, one with and one without reinjection, making a total of eight in all. The duration of a test

run was approximately three hours.

Apparatus

Since comparatively little work has been done in standardizing flue sampling equipment, the apparatus used in this test was specially designed and constructed. The materials, for the most part, were selected from standard stock which is common to most power plants. An itemized parts list is given in the Appendix. Figure 1 illustrates the arrangement of the cyclone type filters and the metering orifice.

Cyclone type filters. After investigating the various types of filters, the cyclone type separator was chosen for the reasons outlined in the REVIEW OF LITERATURE. Four such cyclones were obtained from The Aerotec Corporation. These units, hereafter referred to as Aerotec tubes, have a capacity of 35 cfm, with efficiency for two units operating in series approximately 99% for all particles over eight microns in size. It was felt that this efficiency would be sufficient for the size dust encountered during the test. The connections on these tubes were standard $1\frac{1}{4}$ inch pipe connections. Each sampler, one for inlet and one for outlet, was therefore built around two Aerotec tubes operated in series.

Flue sampling nozzle. The maximum gas flow of 83,000 lb per hr at 350 °F, with a steaming load of 60,000 lb per hr, determined a maximum velocity in the flue of 50 ft per second. Using this velocity and a flow through the sampler of 35 cfm, a nozzle inlet area of 1.45 inches was calculated. Since loads less than rated were to be encountered during the test, $1\frac{1}{2}$ inch I.D. copper tubing was selected for the nozzle

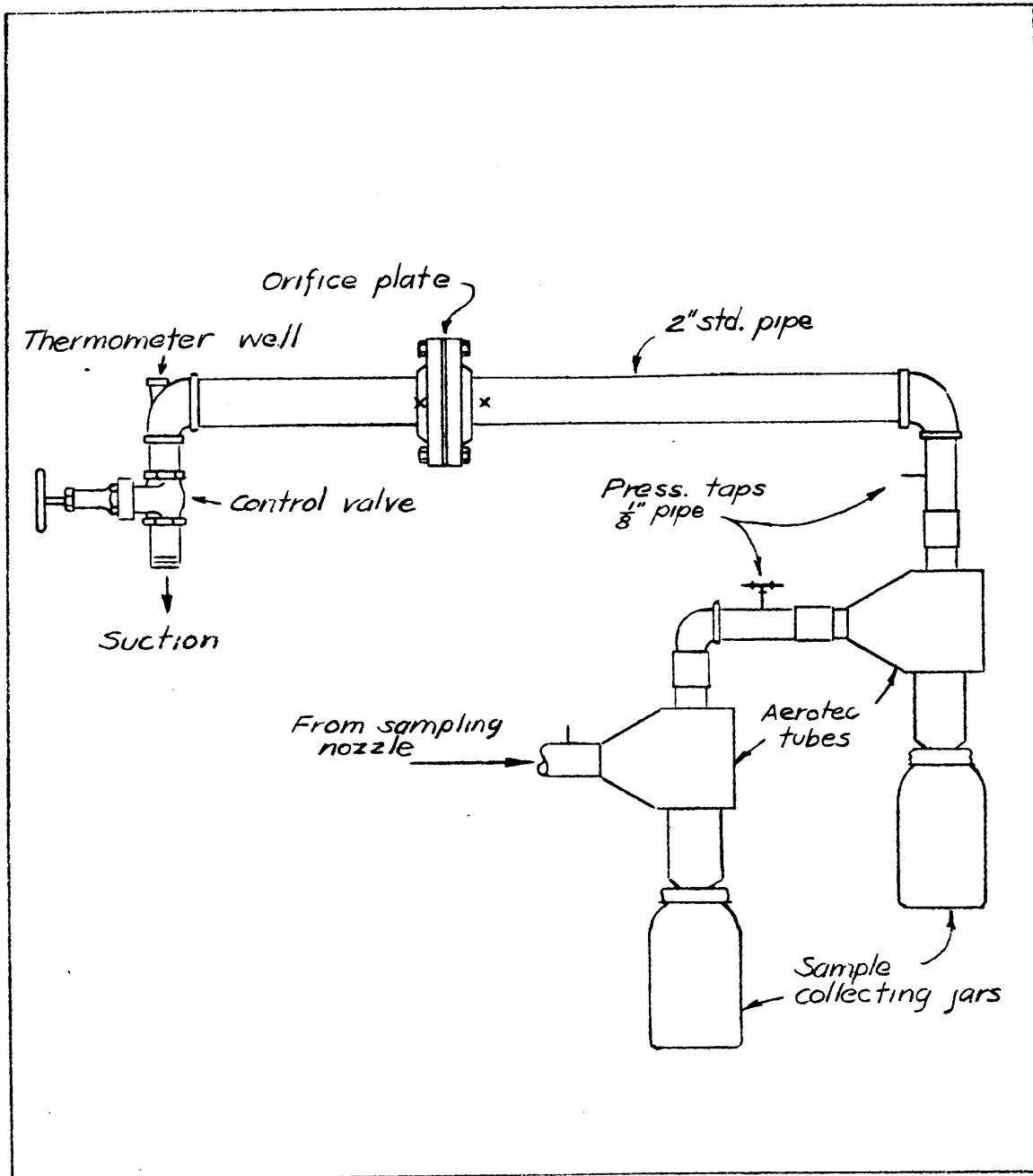

Figure 1. Arrangement of Aerotec tubes and metering orifice.

and probing tube. Attached to the nozzle were three $\frac{1}{2}$ inch O.D. copper tubes to measure static pressure in the flue, static pressure in the nozzle, and total pressure in the flue. The nozzle and static tube detail is shown in figure 2. The nozzle and probing tube were connected to the first Aerotec tube by a section of flexible exhaust pipe, $1\frac{1}{4}$ inch I.D. This flexible tubing, although not guaranteed air tight, was tested with water and was found to be sufficiently air tight so that leakage, if any, would be negligible.

Orifice meter. In order to reduce turbulence and obtain smooth flow at the orifice, a two inch nominal size standard iron pipe was chosen to hold the orifice plate. The orifice plate was the thin plate, sharp edge type with an opening of 1.132 inches. The length of pipe above and below the orifice necessary for undisturbed flow was selected from appropriate tables in the A.S.M.E. Test Code, "Flow Measurement by Means of Standardized Nozzles and Orifice Plates." The straight pipe was 21 inches upstream from the orifice and $10\frac{1}{2}$ inches downstream. The orifice plate was held in the pipe by a two inch pipe flange. Radius pressure taps were used, with the upstream tap one pipe diameter from the orifice and the downstream tap one-half pipe diameter from the orifice.

Control valve. Downstream from the orifice the two inch pipe was reduced in an elbow, which contained the thermometer well, to $1\frac{1}{4}$ inch pipe to receive a gate type control valve and a suction connection.

Suction. The suction for both inlet and outlet samplers was

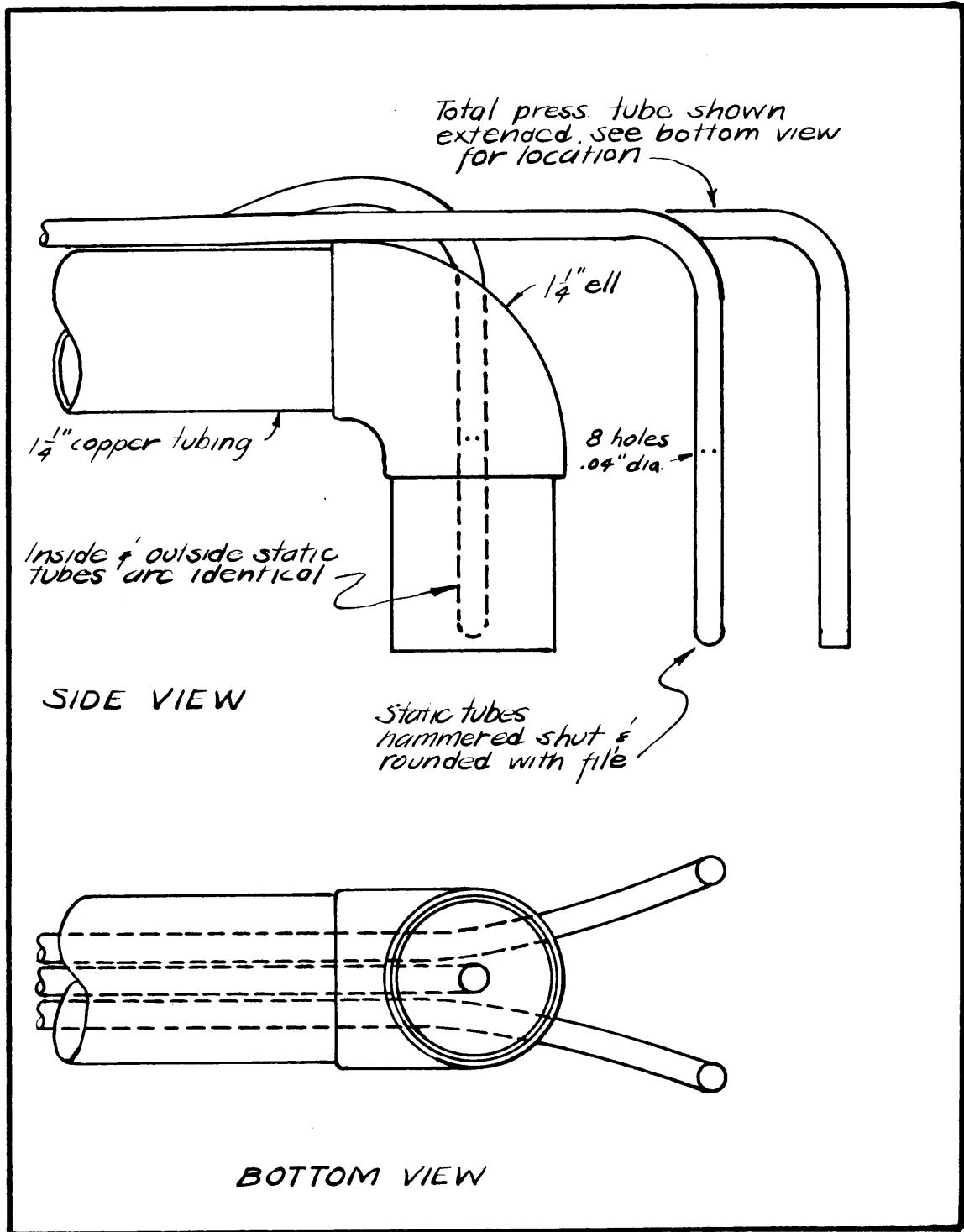

Figure 2. Sampling Nozzle and Pressure tubes.

obtained from a steam jet air ejector, exhausting into the main stack breeching of the Power Plant. This main stack does not serve No. 6 Boiler. The jet was sufficiently large to handle all flows with considerable excess capacity.

Pressure taps. Static pressure taps were arranged to measure drop across the orifice and drop across each Aerotec tube. These connections were drilled and tapped to receive 1/8 inch pipe nipples, and smoothed on the inside of the pipe with a file to remove burrs and rough spots. The orifice installation and pressure connections were made in accordance with A.S.M.E. Test Codes.

Method of Test

The Test Code for Dust Separating Apparatus describes three methods for testing dust collectors, Method A, in which inlet and outlet dust concentration is determined, Method B, in which dust concentration at inlet and quantity of dust caught by the collector is determined, and Method C, in which outlet dust concentration and quantity of dust caught is determined. Because of difficulties which would be encountered in accurately weighing the dust caught, Method A was chosen for this test.

Of considerable importance in obtaining a representative sample of gas from a moving stream is the fact that the sampling velocity and the stream velocity must be equal at all times. To achieve this end an inclined water manometer was connected across the static tube in the nozzle and the static tube in the stack. The pressure differential across these two static pressures was maintained zero at all times, thus assuring equal velocities in nozzle and stack.

A study of the collector location, relative to the boiler, duct work, etc., was made and inlet and outlet sampling cross-sections selected on the basis of smooth anticipated flow, and practical location of dust sampling equipment. The inlet sampling cross-section selected was on a vertical run of flue approximately 20 ft from the tubular type air heater and about six feet from the inlet to the collector. Since, preceding this cross-section, there was considerable length of straight vertical flue, this was considered an ideal sampling location. According to the A.S.M.E. Test Code, "Where the flow is fairly uniform, i.e.,

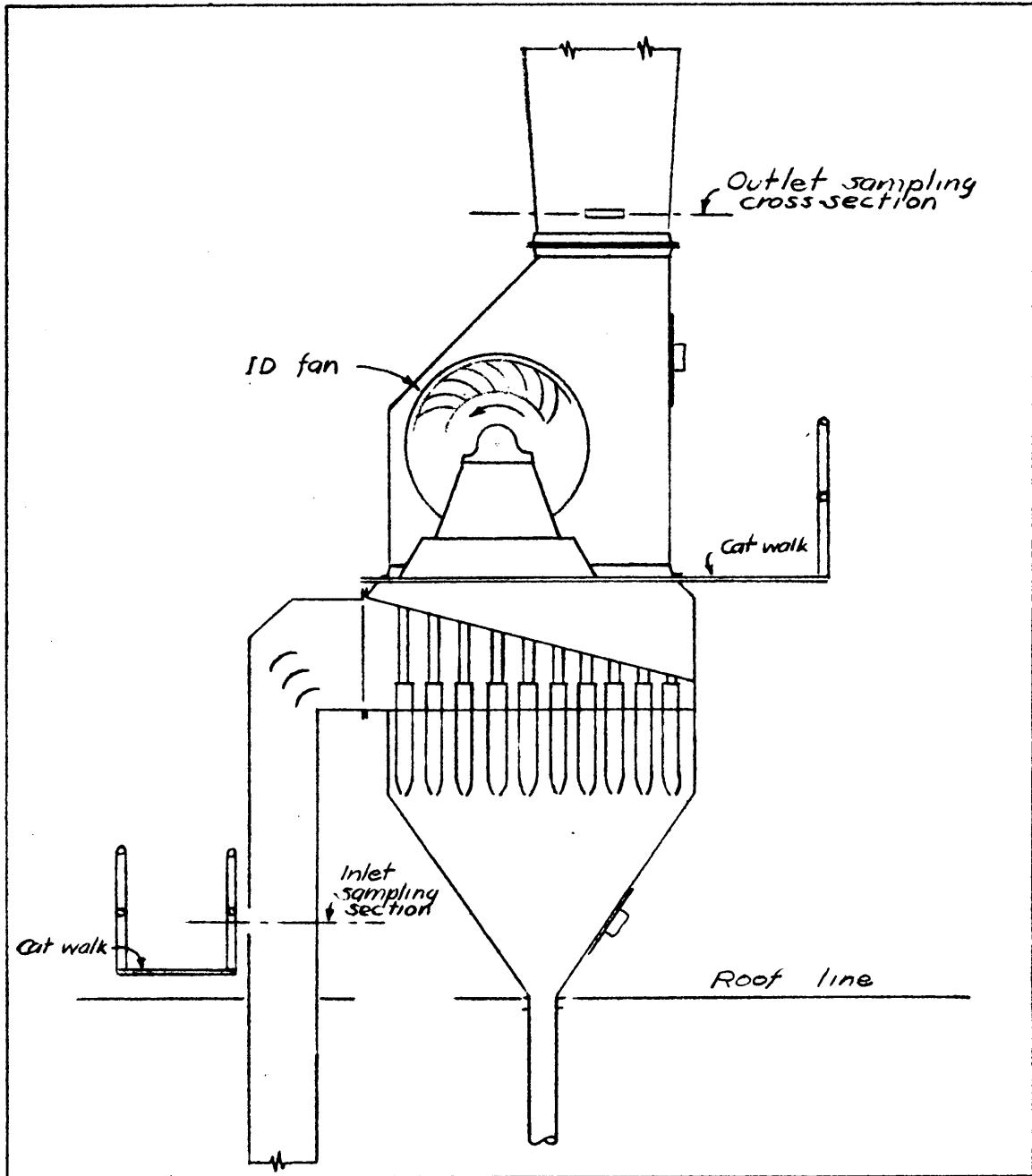

Figure 3. Arrangement of Dust Collector and location of sampling cross-sections.

where the range of velocities does not exceed two to one, from twelve to twenty points can be used for large flues (exceeding 25 sq ft in area) and from eight to twelve points for small flues." Ten sampling points were chosen for this test, so that each point sampled the center of an area 1.5 sq feet.

At the outlet to the collector the induced draft fan is so located that sampling between the collector and the fan was impossible. Therefore the outlet sampling cross-section was chosen above the outlet of the induced draft fan, near the throat of the Thermix stack. It was realized that the proximity of the fan may present difficulties in obtaining a representative sample, however, a cross-section chosen farther up the stack would have necessitated scaffolding to hold the operator and the apparatus. It was felt that, by sampling the larger number of 16 points, a representative sample could be obtained.

Procedure for Operating Samplers

At the inlet to the collector the sampling cross-section measured 10 by $1\frac{1}{2}$ feet. Along the length of the cross-section were five holes, covered with blind flange covers when not in use, just large enough to admit the nozzle and probing tube. These holes were located so that each hole would sample two points. Figure 4 illustrates the inlet sampling cross-section and the sampling points.

The nozzle was positioned and secured at the sampling point by a "U" bolt attached to the supporting leg of the apparatus. After point one was sampled the probing tube was slid into the flue to point two, and again secured by the U bolt.

Before the test run began, a warm-up period of about one-half hour allowed the temperature of the apparatus to reach an equilibrium condition. During the warm-up period the flow of flue gas through the apparatus was approximately the same as during the run. The quart Mason jars, used to collect the sample dust, were cleaned out and allowed to warm-up also by laying them next to the hot flue. The warm-up period was necessary to prevent condensation of the moisture in the flue gas on the apparatus pipe and Aerotec tubes. The entire apparatus, from the probing tube to the orifice, was insulated to prevent excessive heat loss and keep temperatures from falling below the dew point of the gas.

Warm-up jars were used during the warm-up period. At exactly the

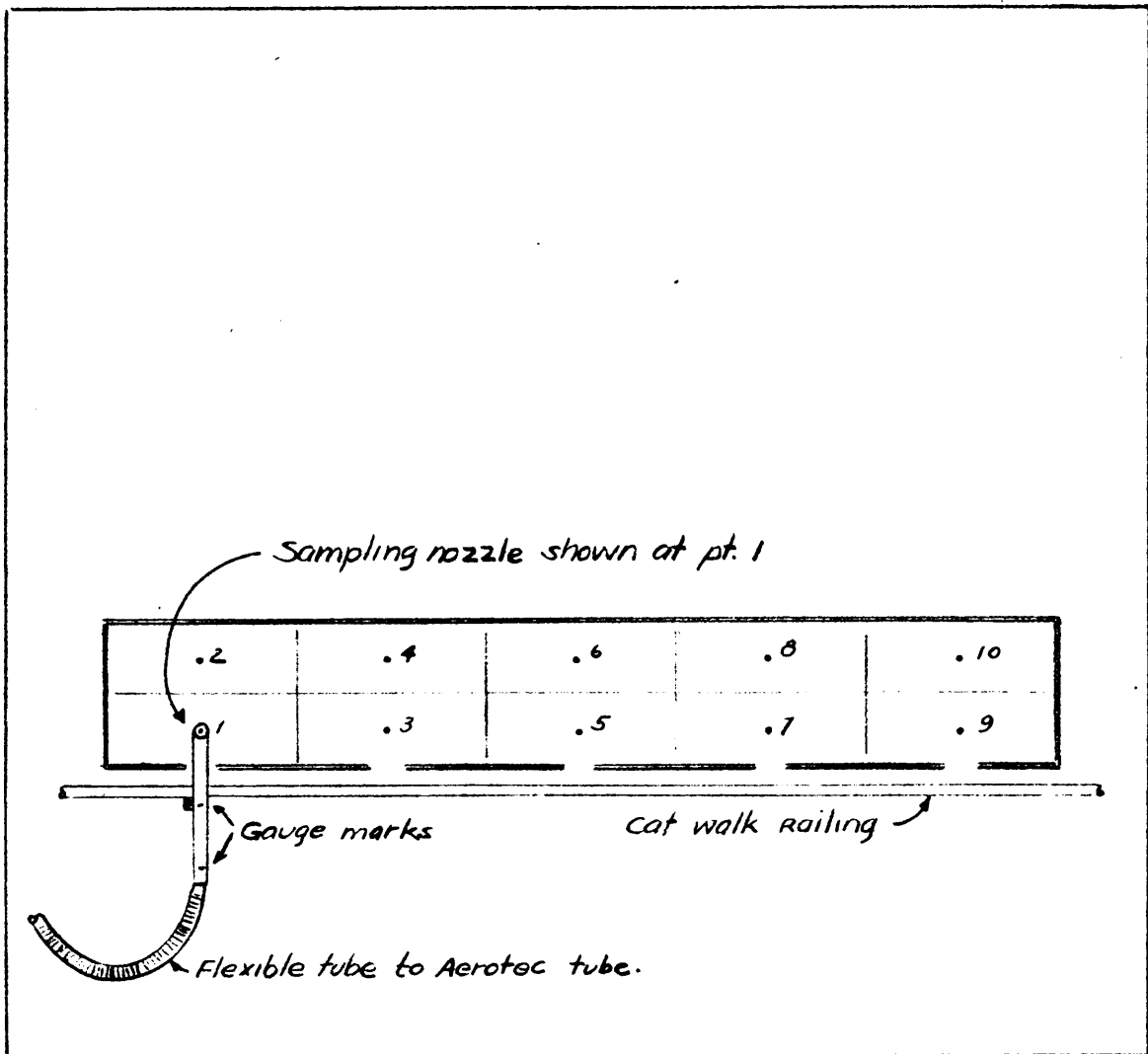

Figure 4. Inlet sampling cross-section and sampling points. The gauge marks determine depth of probing tube in the flue.

start of the test run the warm-up jars were removed and clean, warm jars quickly placed into position at the bottom of each Aerotec tube. The time was recorded as the sampling started at each point. After 14 minutes at point one the nozzle was quickly repositioned at point two. Points one and two were sampled without removing the nozzle, but after point two, the nozzle was removed, the outage time recorded, and the apparatus moved to points three and four, etc.

When point ten was reached the collecting jars were removed. After the first seven minutes at each point the temperature at the orifice, differential pressure across the orifice, static and total pressures, etc., was recorded. The flow was maintained at all times so that the differential pressure of the flue and the nozzle was zero, thus assuring equal flue and nozzle velocities. The space around the probing tube in the sampling hole was sealed by heavy gasket material. This gasket also centered the probing tube in the hole.

At the outlet sampling cross-section the flue was 3 feet $2\frac{1}{2}$ inches square. One hole two inches by nine inches in the flue admitted the probing tube and nozzle. This cross-section was divided into 16 equal square areas with the sampling point located in the center of each area. The sampling nozzle was positioned at each point by use of a template platform just outside the flue and in the same plane as the sampling cross-section. Figure 5 illustrates the outlet sampling cross-section and positioning template.

The operation of the sampler at the outlet was similar to that used

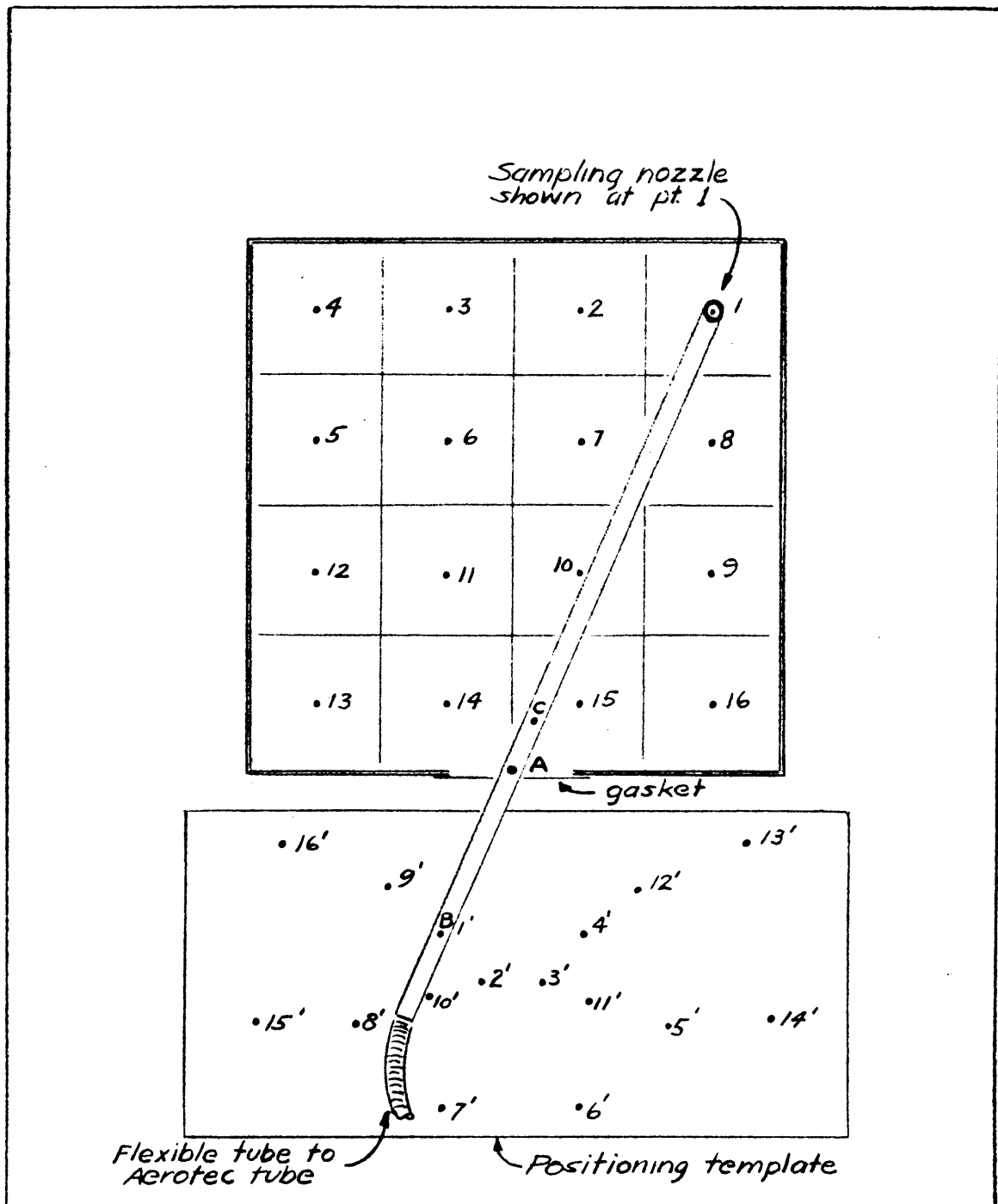

Figure 5. Outlet sampling cross-section and positioning template. By moving point B, on the probing tube, to the points 1', 2', 3', etc. the nozzle will locate at points 1, 2, 3, etc. Point A is the pivot point.

at inlet, however, no outage time was necessary since the sampling nozzle could be moved from point to point in about fifteen to thirty seconds. The time at each point was ten minutes. The time used for sampling each point at inlet and outlet was so proportioned that the total time of the operation of each sampler was approximately equal. The same readings mentioned at inlet were taken at outlet.

Procedure for Seive Analysis

After the complete sample from each run had been weighed and dried in a closet type dryer, each sample was split in a small, riffle type splitter to about 25 to 50 grams. This weight was accurately recorded, and the sample placed on a 325 mesh screen, which was then agitated in a seiving machine for about ten minutes. The amount remaining on the screen was placed on the top of a nest of screens, consisting of 60, 100, 200, and 325 mesh, for reseiving for approximately 15 minutes. The portion of the sample remaining on each screen, and the portion which passed the 325 mesh screen was then weighed and percentages calculated.

The screens were the standard Tyler ten inch size. The seiving machine was driven by an electric motor turning an eccentric fly-wheel. The vibrations set up were transmitted to the screens by two flexible wooden shafts, between which the screens were clamped. The purpose of first placing the sample on the 325 mesh screen was so that the larger particles might assist the smaller ones in passing the screen.

RESULTS

General Information

1. Dates of test: April 5, 14, 16, 19, 1951
2. Dust separator type: Design 6BHC 3 #7-120 Tubular
3. Location: V.P.I. Power Plant
4. Owner: State of Virginia
5. Manufacturer: Prat-Daniel Corporation
6. Purpose: Dust separator serves No. 5 Boiler, Edge-Moore, two drum, with Detroit Rotograte Stoker, equipped to burn collected flyash by reinjection.
7. Object of test: To determine efficiency at different loads with and without reinjection of collected flyash.
8. Test conducted by: James L. Truitt, Jr. and Richard H. Riel

Description, Dimensions, etc.

9. Class of dust: From spreader stoker burning high ash coal.
10. Type of dust separator: Standard Type HC Thermix Tubular Dust Collector, employing the cyclone principle of operation.
11. Rated capacity of unit (gas flow rate):
 - a.) Steaming load: 60,000 lbs/hr.
 - b.) Gas load at 425 °F: 83,000 lbs/hr.
12. Number of cyclone tubes: 120
13. Location of separator in relation to ID fan: After air heater and before ID fan.
14. Cross-sectional area of flue:
 - a.) At separator inlet: 15.0 sq. ft.
 - b.) At separator outlet: 10.3 sq. ft.
 - c.) At inlet sampling cross-section: 15.0 sq. ft.
 - d.) At outlet sampling cross-section: 10.3 sq. ft.
15. Position of flue:
 - a.) At inlet sampling cross-section: vertical
 - b.) At outlet sampling cross-section: vertical
16. General direction of gas flow:
 - a.) At inlet sampling cross-section: up
 - b.) At outlet sampling cross-section: up
17. Method of removing caught dust from hopper:
 - a.) Continuous removal by gravity and high pressure air jets injecting into furnace, when reinjecting.
 - b.) Intermittant removal by ash removal system when not reinjecting.
18. Number of points used for sampling traverse:
 - a.) At inlet sampling cross-section: 10
 - b.) At outlet sampling cross-section: 16

19. Number of dust samplers used:
 - a.) At inlet sampling cross-section: 1
 - b.) At outlet sampling cross-section: 1
20. Type of velocity pressure tubes used: None. Computed by difference of total pressure and static pressure.
21. Type of dust sampler used:
 - a.) Type of exhauster used: Steam jet air ejector.
 - b.) Diameter of metering orifice: 1.132 in.
 - c.) Type of filter: Two Aerotec tubes in series.
 - d.) Location of filter: Outside of flue.
 - e.) Inside diameter of tube leading to filter: 1.25 in.
 - f.) Inside diameter of sampling nozzle: 1.25 in.

Test Data⁷

22. Run Number:	1	2	3	4	
23. Load on the boiler:	25	25	35	35	1000 lb/hr
24. Reinjection of flyash:	yes	no	yes	no	
25. Date of run:	4/19	4/19	4/14	4/14	/51
26. Duration of run:	160	160	156	162	min.
27. Barometric pressure:	27.9	27.9	27.7	27.7	in. Hg
28. Gas flow through separator:	75.6	75.0	85.6	83.0	1000 lb/hr
29. Average velocity of gas:					
a.) At inlet sampling cross-section:	19.3	20.2	23.9	26.7	ft/sec
b.) At outlet sampling cross-section:	42.4	42.1	49.3	47.8	ft/sec
30. Average temperature of gas:					
a.) At inlet sampling cross-section:	382	380	395	400	°F
b.) At outlet sampling cross-section:	322	324	337	337	°F
31. Average static pressure of gas:					
a.) At inlet sampling cross-section:	-1.23	-1.27	-1.58	-1.88	in. water
b.) At outlet sampling cross-section:	-.291	-.295	-.372	-.359	in. water
32. Average pressure drop across collector:	1.03	0.97	1.26	1.25	in. water

Dust Sampler Data

33. Inlet sampling cross-section, see page: 33,34.					
34. Inlet dust sample weight: ...	525	400	1060	460	grams
35. Total quantity of gas sampled at inlet:	61.1	67.5	76.6	85.5	lbs
36. Dust concentration at inlet sampling cross-section, lb dust per 1000 lb gas:	18.9	13.0	30.6	11.9	lb/1000 lb
a.) Expressed by volume: .	5.88	4.06	9.24	3.57	grains/cu ft
37. Total weight of dust entering separator, based on inlet dust concentration and quan- tity of gas passing through:	1430	980	2610	986	lb/hr
38. Outlet sampling cross-section, see page: 35,36.					

7. For sample calculations see Appendix I.

39. Outlet dust sample weight: ..	75.5	52.7	22.3	105.6	grams
40. Total quantity of gas sampled at outlet:	114.4	113.7	149.9	132.7	lbs
41. Dust concentration at outlet sampling cross-section, lb dust per 1000 lb gas:	1.45	1.01	3.28	1.75	lb/1000 lb
a.) Expressed by volume: .	.491	.350	.865	.579	grains/cu ft
42. Total weight of dust leaving separator, based on outlet dust concentration and quantity of gas passing through:	110	76	281	145	lb/hr

Size Analysis of Dust Samples

43. Samples from inlet:					
a.) Weight of sample:	36.5	49.0	34.2	29.9	grams
b.) #50 mesh, 250 microns:	9.85	14.7	5.26	18.4	%
c.) -50 #100 mesh, 149 mic:	18.9	25.7	16.7	24.4	%
d.) -100 #200 mesh, 74 mic:	28.8	27.5	30.1	27.1	%
e.) -200 #325 mesh, 44 mic:	14.5	10.2	17.3	9.36	%
f.) -325 mesh:	27.8	21.8	30.7	20.7	%
44. Samples from outlet:					
a.) Weight of sample:	75.5	52.7	56.9	105.6	grams
b.) #50 mesh, 250 microns:	0.01	0.02	7.00	0.30	%
c.) -50 #100 mesh, 149 mic:	1.05	0.78	12.0	0.70	%
d.) -100 #200 mesh, 74 mic:	2.50	2.90	14.4	3.30	%
e.) -200 #325 mesh, 44 mic:	45.7	15.2	12.8	48.2	%
f.) -325 mesh:	50.3	81.1	53.8	47.5	%
45. Combustible content of dust samples: ⁸					
a.) Inlet sample:	30.2	44.8	15.7	54.7	%
b.) Outlet sample:	25.2	31.5	23.7	42.2	%

Separator Efficiencies

46. Overall efficiency based on inlet and outlet dust concentrations:	92.4	92.1	89.5	85.4	%
47. Efficiency by size:					
a.) #50 mesh:	99.99	99.99	86.00	99.7	%
b.) -50 #100 mesh:	99.50	99.90	92.40	99.50	%
c.) -100 #200 mesh:	99.40	99.20	94.80	98.10	%

8. From the data of H. C. Abercrombie and R. M. Bottoms. "The Effect of ReInjection of Flyash on No. 6 Boiler at the V.P.I. Power Plant," May 1951.

d.)	-200 / 325 mesh:	76.0	88.2	92.3	25.0	%
e.)	-325 mesh:	86.4	70.6	81.5	66.6	%

Fuel and Gas Analysis⁹

48. Type and proximate analysis of fuel (as fired):

a.)	Volatile matter:	13.9	13.8	13.9	14.0	%
b.)	Fixed carbon:	52.3	52.2	57.8	55.2	%
c.)	Ash:	25.1	25.2	22.0	24.7	%
d.)	Moisture:	8.70	8.80	6.30	5.10	%

49. Flue gas analysis:

a.)	CO ₂ :	8.00	8.30	9.40	8.60	%
b.)	O ₂ :	10.4	10.1	8.90	9.50	%
c.)	CO:	0.10	0.10	0.10	0.10	%
d.)	N ₂ :	81.5	81.5	81.6	81.8	%

9. Abercrombie and Bottoms, loc. cit.

36. Outlet sampling cross section.

Load on the boiler: 25,000 lb/hr

a.) Reinjection of flyash	b.) Starting time	c.) Static pressure, "H ₂ O	d.) Pres. drop tube 2, "H ₂ O	e.) Orifice drop, "H ₂ O	f.) Total gas sampled, lbs	g.) Gas vel. in nozzle, ft/sec	h.) Gas sampling rate, lbs/min	i.) Gas temp. at orifice, °F	j.) Gas vel. in flue, ft/sec	k.) Vel. pres. in flue, "H ₂ O	l.) Gas temp. in flue, °F	m.) Sampling position, see sketch
yes	8:16	-.26	.40	.30	6.81	29.0	.672	149	39.0	.22	323	1
yes	8:26	-.27	.39	.30	6.79	28.8	.670	151	36.2	.19	320	2
yes	8:36	-.26	.60	.42	8.02	34.2	.791	151	40.6	.24	320	3
yes	8:46	-.25	.60	.40	7.75	32.6	.765	164	41.6	.25	323	4
yes	8:56	-.22	.38	.28	6.49	27.1	.640	164	33.9	.18	319	5
yes	9:06	-.27	.59	.40	7.76	32.3	.766	160	41.1	.24	319	6
yes	9:16	-.28	.46	.35	7.30	30.4	.719	160	39.9	.23	324	7
yes	9:26	-.36	.65	.45	8.25	35.0	.815	160	42.6	-.26	333	8
yes	9:36	-.36	.45	.35	7.27	30.8	.717	161	46.5	.31	330	9
yes	9:46	-.36	.45	.35	7.30	30.7	.719	159	46.5	.31	329	10
yes	9:56	-.30	.40	.30	7.09	28.4	.669	151	41.6	.25	324	11
yes	10:06	-.35	.45	.37	7.55	31.7	.745	147	49.3	.35	325	12
yes	10:16	-.29	.44	.31	6.94	29.0	.685	144	44.7	.29	319	13
yes	10:26	-.35	.60	.45	8.34	34.8	.823	146	49.0	.35	318	14
yes	10:36	-.21	.10	.12	4.36	16.5	.426	143	27.4	.11	316	15
yes	10:46	-.27	.40	.26	6.38	26.5	.630	139	37.9	.21	316	16
no	2:41	-.25	.57	.41	7.82	33.0	.772	168	40.1	.23	328	1
no	2:51	-.31	.40	.31	6.84	28.7	.674	164	40.8	.24	325	2
no	3:01	-.30	.50	.34	7.19	30.1	.709	160	41.7	.25	324	3
no	3:11	-.25	.51	.38	7.49	31.8	.749	159	40.9	.24	322	4
no	3:21	-.25	.47	.35	7.29	30.5	.719	160	40.9	.24	321	5
no	3:31	-.30	.51	.35	7.29	30.4	.719	158	44.0	.28	320	6
no	3:41	-.32	.45	.32	7.00	39.4	.690	154	43.3	.27	323	7
no	3:51	-.33	.56	.35	7.31	30.8	.721	153	42.5	.26	326	8
no	4:01	-.30	.44	.31	6.89	29.0	.679	152	41.7	.25	326	9
no	4:11	-.33	.47	.35	7.32	30.8	.722	152	44.2	.28	326	10
no	4:21	-.33	.42	.30	6.77	28.2	.668	153	44.2	.28	326	11
no	4:31	-.30	.31	.27	6.54	27.6	.645	153	44.1	.28	323	12
no	4:41	-.25	.52	.36	7.42	31.2	.732	155	45.0	.29	325	13
no	4:51	-.30	.52	.36	7.42	31.2	.732	156	45.7	.30	325	14
no	5:01	-.30	.27	.20	7.55	23.3	.546	151	35.4	.18	323	15
no	5:11	-.30	.35	.25	7.45	31.2	.735	150	39.1	.22	324	16

36. Outlet sampling cross section.

Load on the boiler: 35,000 lb/hr

a.) Re-injection of flyash	b.) Starting time	c.) Static pressure, "H ₂ O	d.) Pres. drop tube 2, "H ₂ O	e.) Orifice drop, "H ₂ O	f.) Total gas sampled, lbs	g.) Gas vel. in nozzle, ft/sec	h.) Gas sampling rate, lbs/min	i.) Gas temp. at orifice, °F	j.) Gas vel. in flue, ft/sec	k.) Vel. pres. in flue, "H ₂ O	l.) Gas temp. in flue, °F	m.) Sampling position, see sketch
no	9:17	-.40	.85	.55	9.18	40.0	.918	130	46.0	.30	338	1
no	9:27	-.40	.65	.55	9.18	40.0	.918	130	49.7	.35	339	2
no	9:37	-.40	1.30	.90	12.80	50.5	1.16	140	57.6	.47	339	3
no	9:48	-.40	1.45	1.05	13.75	54.9	1.25	146	62.5	.55	342	4
no	9:59	-.40	1.25	.90	11.56	51.0	1.16	150	59.8	.50	348	5
no	10:09	-.40	.95	.75	10.60	46.8	1.06	146	50.2	.35	348	6
no	10:19	-.40	.90	.60	9.56	38.3	.870	140	47.8	.32	346	7
no	10:29	-.40	.90	.60	10.60	46.2	1.06	134	47.6	.32	339	8
no	10:40	-.40	.65	.40	7.84	34.0	.784	130	46.0	.30	336	9
no	10:50	-.40	.65	.45	8.35	36.4	.835	126	46.7	.31	336	10
no	11:00	-.40	.65	.45	8.36	36.4	.836	124	46.0	.30	336	11
no	11:10	-.30	.55	.35	8.11	34.0	.737	121	45.9	.30	332	12
no	11:21	-.25	.50	.35	7.41	32.0	.741	116	45.9	.30	332	13
no	11:31	-.30	.55	.35	8.18	31.6	.734	112	45.8	.30	329	14
no	11:42	-.35	.35	.25	6.93	27.1	.630	108	37.4	.20	328	15
no	11:53	-.35	.45	.35	7.50	32.4	.750	104	45.9	.30	330	16
yes	6:33	-.35	.60	.35	7.21	31.2	.721	148	45.9	.30	333	1
yes	6:43	-.40	.55	.35	7.24	31.4	.724	145	46.0	.30	336	2
yes	6:53	-.35	.85	.55	9.10	39.8	.910	142	53.1	.40	339	3
yes	7:03	-.35	.90	.60	9.44	41.1	.944	151	53.1	.40	338	4
yes	7:13	-.35	.80	.55	8.98	39.2	.898	156	49.7	.35	338	5
yes	7:23	-.35	.80	.55	8.98	39.2	.898	156	49.7	.35	338	6
yes	7:33	-.35	.75	.55	8.99	39.1	.899	154	49.7	.35	337	7
yes	7:43	-.35	.70	.50	8.58	37.3	.858	158	46.0	.30	334	8
yes	7:53	-.35	.50	.35	7.20	31.2	.720	153	46.0	.30	334	9
yes	8:03	-.35	.65	.45	8.18	35.6	.818	149	46.0	.30	335	10
yes	8:13	-.35	.60	.40	7.71	33.6	.771	146	46.0	.30	336	11
yes	8:23	-.35	.55	.35	7.22	31.5	.722	146	46.0	.30	337	12
yes	8:33	-.40	.80	.60	10.40	41.4	.945	146	49.9	.35	340	13
yes	8:44	-.40	.80	.60	10.32	41.1	.939	151	53.2	.40	341	14
yes	8:55	-.35	.40	.25	6.07	26.5	.607	150	37.7	.20	339	15
yes	9:05	-.35	.45	.35	7.15	31.2	.715	144	47.1	.25	339	16

Test Data⁷.

22. Run Number:	5	6	7	8	
23. Load on the boiler:	45	45	55	55	1000 lb/hr
24. Reinflection of flyash:	yes	no	yes	no	
25. Date of run:	4/5	4/5	4/16	4/16	/51
26. Duration of run:	194	192	160	163	min.
27. Barometric pressure:	28.0	28.0	27.9	27.9	in. Hg
28. Gas flow through separator:	83.4	88.0	116.6	112.3	1000 lb/hr
29. Average velocity of gas:					
a.) At inlet sampling cross-section:	31.9	29.2	31.8	31.2	ft/sec
b.) At outlet sampling cross-section:	48.5	51.0	66.9	57.1	ft/sec
30. Average temperature of gas:					
a.) At inlet sampling cross-section:	417	416	431	435	°F
b.) At outlet sampling cross-section:	354	353	377	374	°F
31. Average static pressure of gas:					
a.) At inlet sampling cross-section:	-2.07	-1.96	-3.08	-3.14	in. water
b.) At outlet sampling cross-section:	-.380	-.383	-.560	-.550	in. water
32. Average pressure drop across collector:	1.59	1.61	2.35	2.36	in. water

Dust Sampler Data

33. Inlet sampling cross-section, see page: 40,41.					
34. Inlet dust sample weight: ...	900	450	1850	800	grams
35. Total quantity of gas sampled at inlet:	92.0	90.5	93.0	95.6	lbs
36. Dust concentration at inlet sampling cross-section, lb dust per 1000 lb gas:	21.5	11.0	43.8	18.4	lb/1000 lb
a.) Expressed by volume: .	6.41	3.26	12.7	5.34	grains/cu ft
37. Total weight of dust entering separator, based on inlet dust concentration and quantity of gas passing through:	1784	964	4890	2070	lb/hr
38. Outlet sampling cross-section, see page: 42,43.					

7. For sample calculations see Appendix I.

39. Outlet dust sample weight: ..	124.9	95.0	221.3	147.6	grams
40. Total quantity of gas sampled at outlet:	191.0	188.2	206.3	200.0	lbs
41. Dust concentration at outlet sampling cross-section, lb dust per 1000 lb gas:	1.43	1.11	2.36	1.63	lb/1000 lb
a.) Expressed by volume: .	.793	.364	.747	.511	grains/cu ft
42. Total weight of dust leaving separator, based on outlet dust concentration and quantity of gas passing through:	119	97.5	263	183	lb/hr

Size Analysis of Dust Samples

43. Samples from inlet:					
a.) Weight of sample:	28.2	50.6	52.5	20.5	grams
b.) #60 mesh, 250 microns:	8.86	21.9	10.7	20.5	%
c.) -60 #100 mesh, 149 mic:	14.9	23.3	18.5	24.9	%
d.) -100 #200 mesh, 74 mic:	28.0	21.5	29.5	22.9	%
e.) -200 #325 mesh, 44 mic:	16.0	8.70	15.4	8.30	%
f.) -325 mesh:	32.2	24.1	25.9	23.4	%
44. Samples from outlet:					
a.) Weight of sample:	124.9	95.0	53.2	36.5	grams
b.) #60 mesh, 250 microns:	0.70	0.50	0.20	0.30	%
c.) -60 #100 mesh, 149 mic:	1.50	0.70	1.20	0.50	%
d.) -100 #200 mesh, 74 mic:	4.90	1.60	3.00	5.30	%
e.) -200 #325 mesh, 44 mic:	61.0	48.5	2.60	22.2	%
f.) -325 mesh:	31.9	48.7	93.0	70.7	%
45. Combustible content of dust samples:					
a.) Inlet sample:	17.3	38.7	18.7	49.6	%
b.) Outlet sample:	22.5	30.5	26.5	38.1	%

Separator Efficiencies

46. Overall efficiency based on inlet and outlet dust concentrations:	93.4	90.0	94.5	91.2	%
47. Efficiency by size:					
a.) #60 mesh:	99.5	99.5	99.8	99.9	%
b.) -60 #100 mesh:	99.3	99.5	99.4	99.9	%
c.) -100 #200 mesh:	98.9	99.0	99.4	97.5	%

8. From the data of H. C. Abercrombie and R. M. Bottoms.

d.) -200 /325 mesh:	74.9	44.3	99.0	76.5	%
e.) -325 mesh:	93.5	63.7	80.4	73.5	%

Fuel and Gas Analysis⁹

48. Type and proximate analysis of fuel (as fired):

a.) Volatile matter:	15.0	14.5	14.9	14.5	%
b.) Fixed carbon:	58.7	57.2	52.7	52.3	%
c.) Ash:	20.7	21.4	25.5	25.4	%
d.) Moisture:	5.60	6.90	6.80	7.50	%

49. Flue gas analysis:

a.) CO ₂ :	11.7	10.2	12.2	11.9	%
b.) O ₂ :	7.10	7.60	6.30	6.40	%
c.) CO:	0.00	0.10	0.00	0.00	%
d.) N ₂ :	81.2	82.1	81.5	81.7	%

9. Abercrombie and Bottoms, loc. cit.

36. Outlet sampling cross section.

Load on the boiler: 45,000 lb/hr

a.) ReInjection of flyash	b.) Starting time	c.) Static pressure, "H ₂ O	d.) Pres. drop tube 2, "H ₂ O	e.) Orifice drop, "H ₂ O	f.) Total gas sampled, lbs	g.) Gas vel. in nozzle, ft/sec	h.) Gas sampling rate, lbs/min	i.) Gas temp. at orifice, °F	j.) Gas vel. in flue, ft/sec	k.) Vel. pres. in flue, "H ₂ O	l.) Gas temp. in flue, °F	m.) Sampling position, see sketch
ne	3:00	-.35	.83	.65	11.80	44.7	.994	141	46.5	.30	351	1
ne	3:12	-.35	.71	.41	9.80	36.7	.815	146	42.6	.25	351	2
ne	3:24	-.35	1.20	.74	13.50	46.6	1.040	152	53.9	.40	351	3
ne	3:37	-.37	1.62	1.07	15.15	56.3	1.250	156	60.1	.50	359	4
no	3:50	-.40	1.37	.87	13.40	51.1	1.150	164	57.7	.45	366	5
no	4:02	-.35	.95	.55	9.80	40.2	.892	159	45.5	.30	352	6
no	4:13	-.35	1.00	.55	10.75	40.0	.895	154	45.6	.30	348	7
no	4:25	-.35	.75	.50	10.32	38.4	.860	142	46.6	.30	348	8
no	4:37	-.45	1.00	.70	12.25	45.7	1.020	142	53.9	.40	350	9
no	4:49	-.40	.77	.55	10.85	40.4	.905	141	50.3	.35	349	10
ne	5:01	-.33	1.00	.60	11.30	42.3	.942	144	45.1	.28	352	11
no	5:13	-.35	.75	.55	10.90	40.4	.908	138	50.2	.35	346	12
no	5:25	-.45	1.13	.67	12.00	45.2	1.000	142	53.9	.40	352	13
no	5:37	-.50	1.50	1.00	14.45	54.9	1.205	154	66.5	.60	366	14
no	5:49	-.45	.80	.55	10.65	40.7	.889	158	43.0	.25	366	15
no	6:01	-.43	.90	.60	10.30	38.5	.885	153	52.4	.38	354	16
yes	9:00	-.45	1.05	.77	13.00	47.6	1.080	142	53.7	.40	356	1
yes	9:12	-.35	.70	.45	8.50	31.6	.707	151	42.5	.25	360	2
yes	9:24	-.30	.95	.65	11.84	43.2	.986	154	42.5	.25	352	3
yes	9:37	-.37	1.45	.92	15.15	51.0	1.165	156	54.9	.42	349	4
yes	9:49	-.30	.70	.55	10.80	39.6	.900	160	46.4	.30	351	5
yes	10:01	-.45	1.37	1.00	14.60	53.4	1.215	160	60.1	.50	355	6
yes	10:13	-.40	.87	.68	11.95	44.0	.995	169	50.5	.35	361	7
yes	10:25	-.40	.90	.70	12.30	44.8	1.025	153	50.1	.35	350	8
yes	10:37	-.25	.70	.45	9.83	35.8	.818	144	37.8	.20	346	9
yes	10:49	-.35	.85	.62	11.65	42.6	.971	138	45.4	.30	350	10
yes	11:01	-.37	.87	.60	11.45	41.9	.955	142	48.0	.32	352	11
yes	11:13	-.35	.90	.57	11.15	40.7	.930	147	46.4	.30	350	12
yes	11:26	-.25	.60	.45	10.70	33.8	.892	147	37.7	.20	342	13
yes	11:38	-.37	.95	.70	12.30	45.0	1.025	146	48.1	.32	352	14
yes	11:50	-.55	1.05	.72	12.51	46.7	1.041	146	50.6	.35	368	15
yes	12:02	-.57	1.20	.82	13.30	49.5	1.108	152	67.9	.52	370	16

36. Outlet sampling cross section.

Load on the boiler: 55,000 lb/hr

a.) Rejection of flyash	b.) Starting time	c.) Static pressure, "H ₂ O	d.) Pres. drop tube 2, "H ₂ O	e.) Orifice drop, "H ₂ O	f.) Total gas sampled, lbs	g.) Gas vel. in nozzle, ft/sec	h.) Gas sampling rate, lbs/min	i.) Gas temp. at orifice, °F	j.) Gas vel. in flue, ft/sec	k.) Vel. pres. in flue, "H ₂ O	l.) Gas temp. in flue, °F	m.) Sampling position, see sketch
no	9:00	-.60	1.30	.85	11.02	50.2	1.102	179	67.9	.60	381	1
no	9:10	-.70	1.30	.85	11.02	50.2	1.102	180	67.9	.60	381	2
no	9:20	-.50	2.10	1.35	13.80	62.7	1.380	186	71.8	.70	376	3
no	9:30	-.55	2.90	1.75	15.65	71.0	1.565	194	76.7	.80	376	4
no	9:40	-.50	2.25	1.40	13.90	63.7	1.390	204	74.6	.75	381	5
no	9:50	-.60	2.05	1.30	13.35	61.0	1.335	204	72.0	.70	382	6
no	10:00	-.70	1.75	1.10	12.35	57.4	1.235	199	69.4	.65	383	7
no	10:10	-.50	1.55	0.95	11.50	52.1	1.150	198	57.6	.45	376	8
no	10:20	-.65	2.10	1.30	13.45	61.0	1.345	194	69.2	.65	376	9
no	10:30	-.70	2.40	1.50	14.47	65.5	1.447	196	71.8	.70	375	10
no	10:40	-.50	1.60	1.00	11.80	53.7	1.180	198	60.8	.50	379	11
no	10:50	-.45	2.25	1.40	13.97	63.3	1.397	196	63.7	.55	376	12
no	11:00	-.50	2.55	1.50	14.45	65.3	1.445	196	62.7	.75	376	13
no	11:10	-.50	2.20	1.40	14.05	63.3	1.405	190	66.4	.60	374	14
no	11:20	-.50	1.10	0.70	10.05	45.0	1.005	170	53.9	.40	365	15
no	11:30	-.55	1.35	0.90	11.50	51.9	1.150	163	63.5	.55	372	16
yes	3:17	-.50	0.75	0.45	8.25	37.0	0.825	144	57.2	.45	366	1
yes	3:27	-.65	1.40	0.85	11.25	50.3	1.125	152	63.3	.55	366	2
yes	3:37	-.50	1.20	0.75	10.52	46.9	1.052	157	65.8	.60	360	3
yes	3:47	-.50	3.10	1.80	16.15	72.6	1.615	170	76.5	.80	370	4
yes	3:57	-.50	2.75	1.60	15.08	68.1	1.508	182	74.3	.75	375	5
yes	4:07	-.50	1.75	1.05	12.10	55.0	1.210	184	66.6	.60	376	6
yes	4:17	-.70	2.10	1.25	13.30	60.4	1.330	185	69.4	.65	378	7
yes	4:27	-.65	2.20	1.30	13.50	64.1	1.350	194	69.5	.65	383	8
yes	4:37	-.70	2.40	1.45	14.20	64.7	1.420	196	72.0	.70	381	9
yes	4:47	-.65	1.85	1.20	13.00	59.2	1.300	190	69.5	.65	382	10
yes	4:57	-.55	1.90	1.30	13.59	61.4	1.359	184	66.6	.60	378	11
yes	5:07	-.50	1.85	1.15	12.75	58.2	1.275	186	71.9	.70	379	12
yes	5:17	-.40	1.70	1.05	12.15	56.1	1.215	187	69.4	.65	378	13
yes	5:27	-.55	2.00	1.25	13.32	60.4	1.332	185	74.3	.75	378	14
yes	5:39	-.50	1.60	1.00	11.98	44.9	0.997	178	57.3	.45	371	15
yes	5:50	-.50	0.75	0.50	8.88	40.7	0.888	162	50.6	.35	371	16

PERFORMANCE CHARACTERISTICS OF
 PRAT-DANIEL TUBULAR DUST COLLECTOR
 SERVING NO. 6 BOILER AT V.P.I. POWER PLANT
 WHEN BURNING A MIXTURE OF ANTHRACITE
 CULM COAL AND BITUMINOUS

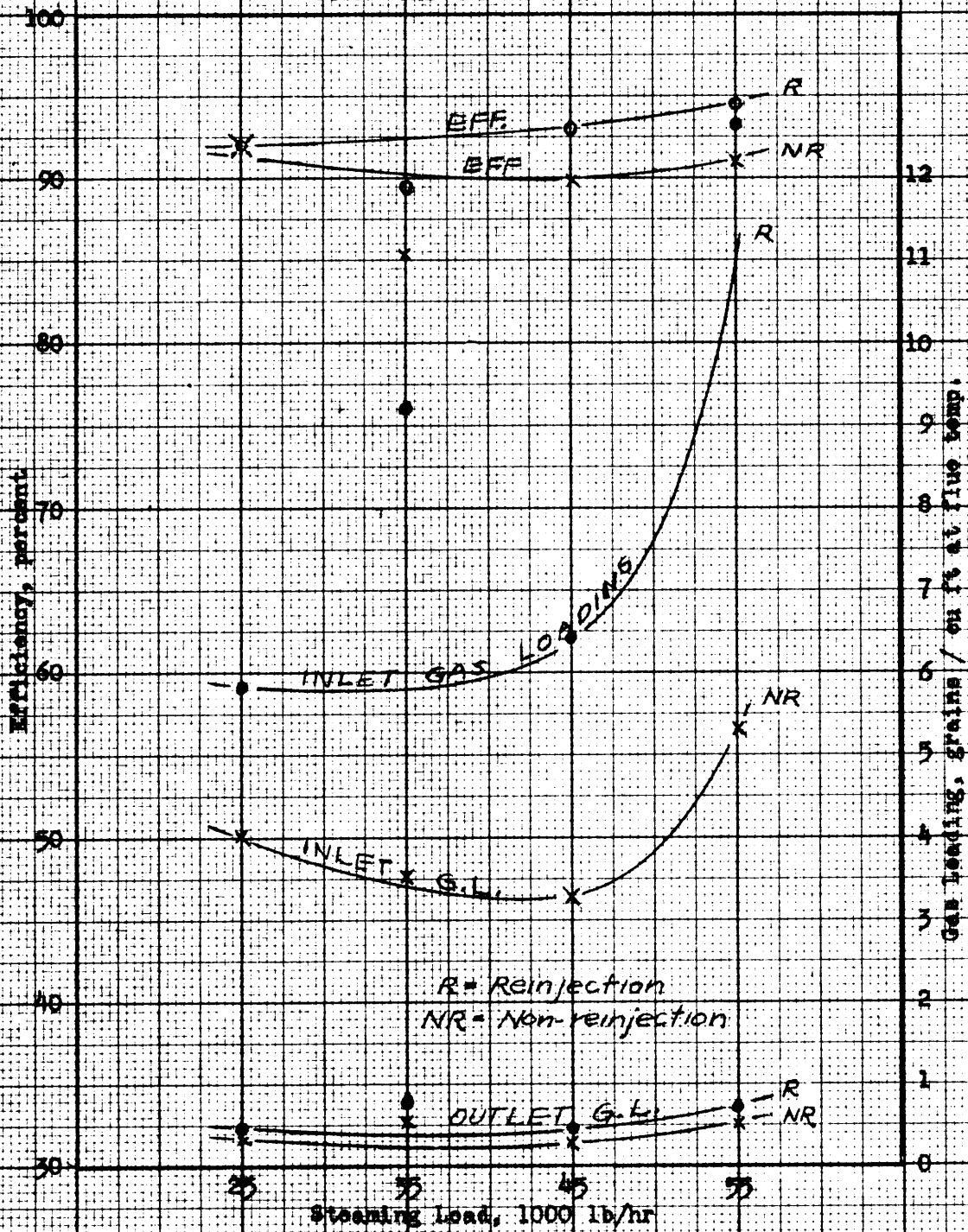

R = Reinjection
 NR = Non-reinjection

Virginia Polytechnic Institute
 Blacksburg, Virginia
 May 31, 1951

20 X 20 PER INCH

DISCUSSION OF RESULTS

From the tests run it was observed that load variations have a pronounced effect both on size analysis and concentration of the flyash. The variation of dust concentration with load was seen to decrease, then increase at the higher loads. This higher gas loading at the low loads was due to lower combustion efficiencies in the furnace, resulting in higher percentages of unburned carbon carried over. The results indicated one exception to this trend. The dust concentration for runs two and three, the 35,000 lb load, was exceptionally high, above the curve. After careful consideration of conditions which might have caused these higher values it was concluded that the higher concentration was caused by excessive fines in the coal burned. If a size analysis of the coal had been obtained, the variations from expected results could have been more easily explained. Since higher velocities result in higher quantities of flyash being carried out, with higher percentages of unburned carbon, maximum loads resulted in highest concentrations and coarsest analyses. For the same load with reinjection, it was noted that dust concentration was higher and size analysis was finer than without reinjection. This is to be expected, since the recirculation of finer material would cause a higher gas loading and a finer analysis. According to Kent's Handbook, "In a given furnace under similar operating conditions the amount of flyash in gases varies directly as the percentage of ash in the coal."

Dust collection efficiencies varied between 85.4% and 94.5%.

Average efficiency for a unit of this type is about 90% for stoker dust of which 30% will pass a 325 mesh screen. Size analysis of the dust entering the separator revealed -325 mesh particles in the neighborhood of 26% by weight. The higher collection efficiencies were obtained at higher boiler ratings and higher draft losses through the collector. This was due to increased velocities, hence increased centrifugal forces in the cyclone units at the higher gas loads.

Comparison of the emission from the collector with the limitations set forth in a Model Ordinance prepared by the A.S.M.E. show the collector to be within the limitations prescribed. The ordinance states that the flyash in the flue gas shall not exceed .85 lb per 1000 lb of gas adjusted to 50% excess air, which is equivalent to a concentration of .257 grains per cu ft at 500 °F. The average value of dust emitted during the test was .456 grains per cu ft at 500 °F, uncorrected for excess air. However, this limitation is waived so long as the dust collector is removing at least 85% of the flyash entering.

Although the results of the test appear favorable, it must be stated that sufficient data was obtained only to indicate trends, and not to formulate definite conclusions. Considerably more runs should be made, in addition to refinements in the apparatus, to obtain more positive results. Specifically, an attempt should be made to improve the accuracy of the pressure readings. The A.S.M.E. Test Code states that all manometers shall be read to .01 inches of water. With the vertical manometers used it was found that, because of pressure and flow variations,

readings no more accurate than .05 inches of water could be obtained, even at relatively stable periods. In addition, it was assumed that the temperature variation throughout the flue was negligible, readings being taken at one sampling position only. In future testing it should be determined whether this assumption is sufficiently true to obtain the accuracy desired.

A better method of seive analysis should be devised, especially for the outlet dust samples, where the majority of the material was in the finer sizes. Little difficulty was encountered in obtaining uniform and reasonable results with the inlet samples. The larger size particles obtained at inlet aided materially in effectively screening the small particles.

At the outlet the percentage of larger particles, #60 mesh, was negligible, thus making the first screening ineffective. Considerable difficulty was experienced in sizing this finer dust, and the accuracy of results are subject to doubt. It was first believed that the sample was not dry enough, so the samples were repeatedly dried and screening was even attempted with hot samples taken directly out of the drier. Some investigators claim that electric charges on the particles cause them to agglomerate, making accurate screening impossible, and methods have been developed with some success in which an electric charge is placed on the screen to reduce the charges on the particles. Equipment of this kind was not available for this analysis.

It is therefore felt that the calculation of efficiency by sizes

is not representative for the dust collector tested. The analysis of the dust entering however, is an accurate determination and is therefore considered to be representative for the boiler range over which the test was conducted.

In conclusion, the accuracy or efficiency of the various instruments and equipment, such as Aerotec tubes, thermometers, pitot tubes, static tubes, etc., should also be taken into consideration as well as the personal error of the individuals involved, and the probable error or results considered.

BIBLIOGRAPHY

- A.S.M.E. Power Test Code for Dust Separating Apparatus, December 1941.
- A.S.M.E. Power Test Code, Instruments and Apparatus, Part 5, Chapter 4, Flow Measurement by Means of Standardized Nozzles and Orifice Plates.
- Gaffert, Gustaf A., Steam Power Stations, Third Edition, New York, McGraw-Hill Book Company, 1946.
- Gladden, C. S., "Cinders and Flyash Factors When Burning Small Anthracite Coal on Traveling Grate Stokers," Transactions A.S.M.E., vol 69, pp. 191.
- Hardie, P. H., "Cinder and Flyash Measurements," Combustion, vol VI, March 1935, pp. 10-16 and (discussion) April, 1935, pp. 37-38, and May, 1935, pp. 35.
- Kent's Mechanical Engineering Handbook, Power, Twelfth Edition, New York, John Wiley and Sons, c. 1950.
- Prat-Daniel Corporation, "Prat-Daniel Tubular Dust Collectors Valmont Type S and Standard Type HC," Catalog 250S.
- Prat-Daniel Corporation, "Thermix Products," Catalog 200, p. 16.
- Stern, A. C., "The Measurement and Properties of Cinders and Flyash," Combustion, vol. IV, June-July, 1933, pp. 35-47.
- Whiton, L. C., Jr., "Research on Cyclone Dust Collectors," Rock Products, February 27, 1932.

**The vita has been removed from
the scanned document**

**The vita has been removed from
the scanned document**

APPENDIX I

Sample Calculations

The equations that were given in the A.S.M.E. Power Test Code for Dust Separator Apparatus were used exclusively. Item numbers refer to item numbers in the section of RESULTS. Sample calculations are for run No. 1, outlet sampling cross-section, unless otherwise specified.

27. Gas flow through separator:

$$W_g = V_f A_f d_f (3600)$$

V_f = average velocity in flue, ft/sec

A_f = area of sampling cross-section, sq ft

d_f = density of flue gas at sampling cross-section, lb/cu ft

$$d_f = 1.35 p_{sf} / 460 + t_f$$

p_{sf} = average static pressure at sampling cross-section, "Hg

t_f = average temperature of flue at sampling cross-section

$$W_g = (42.4)(10.3) \frac{(1.35)(27.9)(3600)}{(460 + 322)} = 75,600 \text{ lb/hr}$$

28. Average velocity of gas:

The average velocity of the gas was obtained from the velocities at the various points. Calculations are for sampling point 1.

$$V_f = 1096 \sqrt{\frac{P_{vf}}{d_f}}$$

P_{vf} = velocity pressure in flue, in. water

P_{vf} = total pressure - static pressure

d_f = density in flue

Note: Since static pressure in flue was not greater than 0.5 in. water, its effect was negligible, hence barometric pressure was used.

$$V_f = \frac{1096}{60} \sqrt{\frac{(.220)(460 + 323)}{(1.35)(27.9)}} = 39 \text{ ft/sec}$$

38. Total quantity of gas sampled:

The total quantity was the sum of the quantities sampled at each point. At each point the quantity in lb was:

$$W_{g_s} = 65,800 A_o C_o T_o \sqrt{d_o H_o}$$

A_o = area of the orifice, sq ft

$$A_o = \frac{(\text{Pi})(1.132)^2}{(4) 144} = .007 \text{ sq ft}$$

C_o = flow coefficient of the orifice. The volume through the orifice was assumed to vary between 10-35 cfm.

With this assumption the Reynolds Number was obtained from fig. 2(c), page 12 of the Power Test Code, Part 5, Chapter 4, "Flow Measurement by Means of Standardized Nozzles and Orifice Plates." The Reynolds Number varied from 10,000 to 24,000 for these assumed flows. Using these Reynolds Numbers and the diameter ratio of the orifice, $D_{\text{orifice}}/D_{\text{pipe}} = 1.132/2.07 = .548$, the flow coefficient was found to be between .64 and .66. Therefore, it was decided to use .65 throughout the test.

$$d_o = 1.35 p_{so}/460 + t_o$$

p_{so} = static pressure at orifice in "Hg. The range of static

pressure when converted to "Hg vacuum would be .11 to .81 inches. This small static pressure would have negligible effect on the density, therefore p_{s0} was assumed to be barometric pressure.

t_o = temperature at the orifice

T_o = time over which the flow is being computed, hrs

H_o = orifice differential, in. water

$$W_{g_s} = (65,800)(.007)(.65) \frac{(10)}{(60)} \sqrt{(.0619)(.30)} = 6.80 \text{ lb}$$

40. Dust concentration:

$$m_1 = \text{lb dust}/1000 \text{ lb gas} = \frac{75.5 \text{ gms.}}{453.6 \text{ gms/lb}} \times \frac{1}{114.4 \text{ lb gas}} \times 1000$$

$$m_1 = 1.45 \text{ lb}/1000 \text{ lb}$$

Expressed volumetrically:

$$\text{grains/cu ft} = 7000 d_f m_1 = (7000)(.0481)(.00145) = .488$$

41. Total weight of dust leaving separator:

$$W_{d2} = (.00145)(75,600) = 110 \text{ lb/hr}$$

45. Overall efficiency, based on inlet and outlet dust concentrations:

$$E = \frac{m_1 - m_2}{m_1} \times 100\%$$

m_1 = inlet concentration, lb/1000 lb

m_2 = outlet concentration, lb/1000 lb

$$E = \frac{18.9 - 1.45}{18.9} \times 100\% = 92.4\%$$

46. Efficiency by size:

$$E_{/60} = \frac{S'_{/60} - (1 - E/100)S''_{/60}}{S'_{/60}}$$

$S'_{/60}$ = percent of /60 mesh particles at inlet

$S''_{/60}$ = percent of /60 mesh particles at outlet

$$E_{/60} = \frac{9.86 - (1 - 92.4/100)(.01)}{9.86} = 99.99\%$$

Apparatus Parts List for One Unit

1. Sampling nozzle, copper tubing
2. Probing tube
3. Flexible tubing
4. Aerotec tube, two required
5. Orifice plate
6. Orifice pipe, two inch standard pipe
7. Control valve
8. Collecting jars
9. Connecting pipe, $1\frac{1}{4}$ inch standard pipe
10. Suitable frame for supporting orifice pipe
11. Six "U" tube water manometers and rubber connecting tubes
12. Suction or exhausting device

RECOMMENDATIONS FOR THE REFINEMENT OF APPARATUS

1. In order to secure more accurate pressure readings it is suggested that inclined water manometers be used in place of the vertical water manometers that were used. Readings accurate to .01 inch of water would be desirable.
2. Some means should be devised for checking the efficiency of the Aerotec tubes. This would probably be some type of cloth filter placed between the orifice and the control valve.
3. It would be desirable to obtain temperature readings at the sampling points. This could be obtained by placing a thermocouple on the sampling nozzle.
4. It is also recommended that a size analysis of the coal burned be made of future tests of this type.
5. A better means should be devised to obtain a more accurate analysis of the outlet dust samples.

ABSTRACT

Dust Collector Efficiency Test¹

A test to determine overall collection efficiency was made on a standard Prat-Daniel Tubular Type Dust Collector serving No. 6 Boiler in the V.P.I. Power Plant. The boiler was designed to generate 60,000 lb per hr with bituminous coal, and 45,000 lb per hr with anthracite culm coal. The unit was equipped with a Detroit Roto-grate Stoker. The coal fired was a mixture of anthracite culm and bituminous coal. The apparatus was made and the test conducted in accordance with the A.S.M.E. Test Code for Dust Separating Apparatus. Eight runs of approximately three hours duration were made, and samples of flue gas taken at inlet and outlet of the collector for boiler steaming loads of 25, 35, 45, and 55 thousand lbs per hr, with and without reinjection of the collected flyash. From the samples collected, dust concentrations in lb per 1000 lb of gas were determined, and the overall efficiency calculated.

The efficiencies varied between 85% at low loads to 94% at high loads. Efficiency without reinjection was slightly less than with reinjection. Dust concentration at inlet varied from about six to twelve grains per cu ft at flue temperature while reinjecting, and from three to six grains per cu ft when not reinjecting. Dust emitted to the atmosphere was never more than eight tenths grain per cu ft.

1. James L. Truitt, Jr. and Richard H. Riel, "The Efficiency of the Dust Collector on No. 6 Boiler in the V.P.I. Power Plant," Virginia Polytechnic Institute, May 1951.