

FINAL  
CONTRACT REPORT  
VTRC 10-CR2

**GRADE 300 PRESTRESSING STRAND  
AND THE EFFECT OF  
VERTICAL CASTING POSITION**

CARIN ROBERTS-WOLLMANN  
Associate Professor  
Via Department of Civil and Environmental Engineering  
Virginia Tech

TOMMY COUSINS, Ph.D., P.E.  
Professor  
Via Department of Civil and Environmental Engineering  
Virginia Tech

CHRIS CARROLL  
Assistant Professor  
Department of Civil Engineering  
University of Louisiana, Lafayette



**Standard Title Page - Report on Federally Funded Project**

1. Report No.: FHWA/VTRC 10-CR2	2. Government Accession No.:	3. Recipient's Catalog No.:	
4. Title and Subtitle: Grade 300 Prestressing Strand and the Effect of Vertical Casting Position		5. Report Date: September 2009	
		6. Performing Organization Code:	
7. Author(s): Carin Roberts-Wollmann, Thomas E. Cousins, and Christopher Carroll		8. Performing Organization Report No.: VTRC 10-CR2	
9. Performing Organization and Address: Virginia Transportation Research Council 530 Edgemont Road Charlottesville, VA 22903		10. Work Unit No. (TRAIS):	
		11. Contract or Grant No.: 77921	
12. Sponsoring Agencies' Name and Address: Virginia Department of Transportation      Federal Highway Administration 1401 E. Broad Street                              400 North 8th Street, Room 750 Richmond, VA 23219                              Richmond, VA 23219-4825		13. Type of Report and Period Covered: Final	
		14. Sponsoring Agency Code:	
15. Supplementary Notes: This project was financed with a grant from the FHWA Innovative Bridge Research and Deployment Program at an estimated cost of \$97,660.			
16. Abstract: <p>The purpose of this investigation was (1) to compare the differences in the transfer length, development length, and flexural strength among Grade 300 strand, the traditional Grade 270 strand, and the predictions of these properties obtained using current code equations for prestressed concrete members, and (2) to determine the effect the as-cast vertical location of the strands (top-strand effect) on these properties. The current code provisions by the American Association of State Highway and Transportation Officials and the American Concrete Institute are based on years of experimental research on the traditional Grade 270 strand.</p> <p>The scope of this project was limited to the fabrication and testing of 20 pretensioned, prestressed beams, 10 of which contained Grade 270 and 10 of which contained Grade 300 strands constructed and tested in the Structures and Materials Laboratory at Virginia Tech.</p> <p>The increase in strand strength was found to influence transfer length, development length, and flexural strength; the as-cast vertical location was found to influence only transfer length and, in turn, development length. Transfer lengths of the Grade 300 strand had an average increase of 10 percent compared to the transfer lengths of the Grade 270 strand. Development lengths for the Grade 300 strand were also shown to increase compared to the Grade 270 strand. Flexural bond lengths were found to be relatively the same for both strand strengths, indicating the increase to be primarily dependent on the increase in transfer length. Minimum flexural bond lengths that resulted in flexural failures were found to be in the range of 45 to 50 in for both strand strengths. The influence of strand strength on flexural strength was also evaluated. As expected, members cast with ½ in diameter, Grade 300 strands had about 11 percent higher nominal moment capacities than did those cast with ½ in diameter, Grade 270 strands. Contrary to the historical definition, the top-bar/strand effect was found to be more dependent on the amount of concrete cast above the strand than the amount below it, with transfer lengths showing a steady increase with a decrease in the amount of concrete cast above the strand. The current equations for flexural strength were found to give adequate estimates for flexural strength, although a decrease in ductility was noted.</p> <p>The study recommends the following:</p> <ol style="list-style-type: none"> <li>VDOT's Structure and Bridge Division should use the current AASHTO equation for transfer length and development length for flexural members containing Grade 300 strand cast in non-top strand situations.</li> <li>VDOT's Structure and Bridge Division should use the current ACI and AASHTO provisions for the calculation of nominal moment capacity for flexural members containing Grade 300 prestressing strands.</li> </ol>			
17 Key Words: Grade 300 strand, Grade 270 strand, transfer length, development length, flexural capacity, flexural bond strength		18. Distribution Statement: No restrictions. This document is available to the public through NTIS, Springfield, VA 22161.	
19. Security Classif. (of this report): Unclassified	20. Security Classif. (of this page): Unclassified	21. No. of Pages: 37	22. Price:

**FINAL CONTRACT REPORT**

**GRADE 300 PRESTRESSING STRAND AND THE EFFECT OF VERTICAL CASTING  
POSITION**

**Carin Roberts-Wollmann**  
**Associate Professor**  
**Via Department of Civil and Environmental Engineering**  
**Virginia Tech**

**Tommy Cousins, Ph.D., P.E.**  
**Professor**  
**Via Department of Civil and Environmental Engineering**  
**Virginia Tech**

**Chris Carroll**  
**Assistant Professor**  
**Department of Civil Engineering**  
**University of Louisiana, Lafayette**

*Project Manager*  
Jose P. Gomez, Ph.D., P.E., Virginia Transportation Research Council

Contract Research Sponsored by the  
Virginia Transportation Research Council  
(A partnership of the Virginia Department of Transportation  
and the University of Virginia since 1948)

In Cooperation with the U.S. Department of Transportation  
Federal Highway Administration

Charlottesville, Virginia

September 2009  
VTRC 10-CR2

## **DISCLAIMER**

The project that is the subject of this report was done under contract for the Virginia Department of Transportation, Virginia Transportation Research Council. The contents of this report reflect the views of the author(s), who is responsible for the facts and the accuracy of the data presented herein. The contents do not necessarily reflect the official views or policies of the Virginia Department of Transportation, the Commonwealth Transportation Board, or the Federal Highway Administration. This report does not constitute a standard, specification, or regulation. Any inclusion of manufacturer names, trade names, or trademarks is for identification purposes only and is not to be considered an endorsement.

Each contract report is peer reviewed and accepted for publication by Research Council staff with expertise in related technical areas. Final editing and proofreading of the report are performed by the contractor.

Copyright 2009 by the Commonwealth of Virginia.  
All rights reserved.

## ABSTRACT

The purpose of this investigation was (1) to compare the differences in the transfer length, development length, and flexural strength among Grade 300 strand, the traditional Grade 270 strand, and the predictions of these properties obtained using current code equations for prestressed concrete members, and (2) to determine the effect the as-cast vertical location of the strands (top-strand effect) on these properties. The current code provisions by the American Association of State Highway and Transportation Officials and the American Concrete Institute are based on years of experimental research on the traditional Grade 270 strand.

The scope of this project was limited to the fabrication and testing of 20 pretensioned, prestressed beams, 10 of which contained Grade 270 and 10 of which contained Grade 300 strands constructed and tested in the Structures and Materials Laboratory at Virginia Tech.

The increase in strand strength was found to influence transfer length, development length, and flexural strength; the as-cast vertical location was found to influence only transfer length and, in turn, development length. Transfer lengths of the Grade 300 strand had an average increase of 10 percent compared to the transfer lengths of the Grade 270 strand. Development lengths for the Grade 300 strand were also shown to increase compared to the Grade 270 strand. Flexural bond lengths were found to be relatively the same for both strand strengths, indicating the increase to be primarily dependent on the increase in transfer length. Minimum flexural bond lengths that resulted in flexural failures were found to be in the range of 45 to 50 in for both strand strengths. The influence of strand strength on flexural strength was also evaluated. As expected, members cast with  $\frac{1}{2}$  in diameter, Grade 300 strands had about 11 percent higher nominal moment capacities than did those cast with  $\frac{1}{2}$  in diameter, Grade 270 strands. Contrary to the historical definition, the top-bar/strand effect was found to be more dependent on the amount of concrete cast above the strand than the amount below it, with transfer lengths showing a steady increase with a decrease in the amount of concrete cast above the strand. The current equations for flexural strength were found to give adequate estimates for flexural strength, although a decrease in ductility was noted.

The study recommends that

1. VDOT's Structure and Bridge Division should use the current AASHTO equation for transfer length and development length for flexural members containing Grade 300 strand cast in non-top strand situations.
2. VDOT's Structure and Bridge Division should use the current ACI and AASHTO provisions for the calculation of nominal moment capacity for flexural members containing Grade 300 prestressing strands.

## **FINAL CONTRACT REPORT**

### **GRADE 300 PRESTRESSING STRAND AND THE EFFECT OF VERTICAL CASTING POSITION**

**Carin Roberts-Wollmann**  
**Associate Professor**  
**Via Department of Civil and Environmental Engineering**  
**Virginia Tech**

**Tommy Cousins, Ph.D., P.E.**  
**Professor**  
**Via Department of Civil and Environmental Engineering**  
**Virginia Tech**

**Chris Carroll**  
**Assistant Professor**  
**Department of Civil Engineering**  
**University of Louisiana, Lafayette**

## **INTRODUCTION**

The use of prestressed concrete girders has become a common theme in bridge construction; however, span lengths have been limited by concrete compressive strengths and the maximum number of strands that can be placed in a section. In the past, high concrete strengths have typically ranged between 6,000 psi and 8,000 psi, but recent advancements have resulted in concrete strengths well in excess of 10,000 psi. With higher concrete compressive strengths come increased allowable compressive and tensile stresses at transfer and service loads, as well as a small increase in flexural strength. Higher concrete compressive strengths also provide an opportunity for an increased resultant tensile force, however, the prestressing strands traditionally used are also limited by their cross-sectional areas and ultimate tensile strength. Historically, ½ in diameter and ½ in diameter super strands with an ultimate tensile strength of 270 ksi (Grade 270) have been used. In order to develop higher resultant tensile forces, a 0.6 in diameter strand has been used in some cases, but has also been limited by the ultimate tensile strength of 270 ksi. As with concrete compressive strengths, recent developments have resulted in a higher strength strand with an ultimate tensile strength of 300 ksi (Grade 300 strand).

Grade 300 prestressing strand was expected to provide an 11 percent increase in the available prestress force per strand, which in turn would provide two primary benefits. The first benefit of an increase in available prestress force would be a reduction in the number of strands needed in a member to provide the design prestress force of a beam originally containing Grade 270 strands. Such a reduction would result in a lower center of gravity of the strands, thus increasing the moment arm and flexural capacity of the member. The second benefit of an increase in available prestress force per strand would be an increased resultant tensile force using

the same number of strands in a beam originally designed with Grade 270 strands, thus increasing the magnitude of the internal couple, and in turn increasing the flexural capacity. With an increase in flexural capacities also come economic benefits. An increased flexural capacity could allow for longer span lengths with the same number of girders in a bridge design compared to girders originally containing Grade 270 strands, thus eliminating piers and reducing substructure costs. An increased flexural capacity could also allow for a reduction in the number of girders transversely spaced in a bridge design originally designed for a specific span with girders containing Grade 270 strands, thus reducing initial costs due to fabrication, transportation, and erection. The use of girders containing Grade 300 strands could have a substantial economic impact on the bridge industry significantly reducing the costs associated with design, materials, fabrication, transportation and construction.

## PURPOSE AND SCOPE

The purpose of this investigation was (1) to compare the differences in the transfer length, development length, and flexural strength among Grade 300 strand, the traditional Grade 270 strand, and the predictions of these properties obtained using current code equations for prestressed concrete members; and (2) to determine the effect the as-cast vertical location of the strands (top-strand effect) on these properties. The current code provisions by the American Association of State Highway and Transportation Officials (AASHTO) and the American Concrete Institute (ACI) are based on years of experimental research on the traditional Grade 270 strand.

The scope of this project was limited to the fabrication and testing of 20 pretensioned, prestressed beams, 10 of which contained Grade 270 and 10 of which contained Grade 300 strands constructed and tested in the Structures and Materials Laboratory at Virginia Tech.

## METHODS

Table 1 breaks down the test specimens into the groups in which they were constructed.

**Table 1. Test Specimen Breakdown**

<b>Pour</b>	<b>No. of Specimens</b>	<b>Strand Type</b>	<b>Strand Grade</b>	$f_{si}$	<b>Description</b>
1	2	0.5 in	270 ksi 300 ksi	$0.67*f_{pu}$	Small T-beams
2	4	0.5 in	270 ksi 300 ksi	$0.67*f_{pu}$	Small T-beams
3	4	0.5 in super	270 ksi 300 ksi	$0.67*f_{pu}$	Medium T-beams
4	2	0.5 in super	270 ksi 300 ksi	$0.67*f_{pu}$	Medium T-beams
5	4	0.5 in super	270 ksi 300 ksi	$0.75*f_{pu}$	Medium T-beams
6	2 2	0.5 in super 0.6 in	270 ksi	$0.75*f_{pu}$	Medium & Large T-beams

The T-beam specimens were 24 ft long, allowing for two flexural tests per specimen. The specimens included a transfer zone at each end of each specimen, which provided a total of 40 transfer zones. One of the transfer zones was lost due to a flash setting of the concrete while casting the specimen. Of the twenty T-beam test specimens, the size of the cross-section varied with strand type: including low-relaxation ½ in diameter regular, ½ in diameter super, and 0.6 in diameter strands each having a cross-sectional area of 0.153 in<sup>2</sup>, 0.167 in<sup>2</sup>, and 0.217 in<sup>2</sup>, respectively. With an increase in cross-sectional area, also comes an increase in the initial prestress force. Therefore, the prestress force in the beams containing 0.6 in diameter strands was significantly higher than in those containing ½ in diameter super strands and the prestress force in beams containing ½ in diameter super strands was significantly higher than in those containing ½ in diameter regular strands. For this reason, the size of the cross section varied with the strand type. In addition to the strand type, the size and shape of the cross-section was also influenced by the desired tensile strain in the strand at the ultimate flexural capacity of the member. Tests have shown development length to be dependent on the strain in the strand at the time of failure, thus as recommended by Buckner (1995), the cross section was designed such that the strain in the strand at the ultimate flexural capacity would be greater than the minimum required elongation of 3.5 percent. The relatively wide flanges of the T-beam specimens reduced the depth to the neutral axis, resulting in a high level of strain in the prestressing strands as recommended. The increase in tensile strain also provided a high level of ductility in the test specimens. The three cross sections used throughout the project are shown in Figure 1, while the section properties are shown in Table 2. The small, medium, and large beams each contained ½ in diameter regular, ½ in diameter super, and 0.6 in diameter strands, respectively.

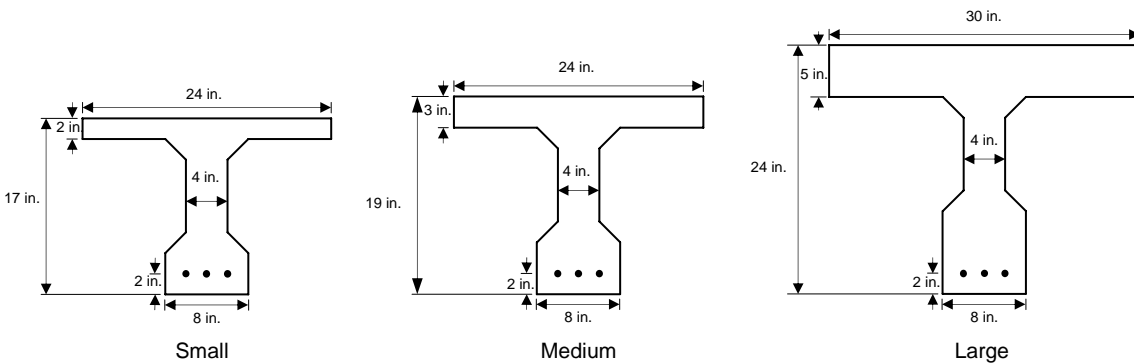

Figure 1. T-beam cross-sections.

Table 2. T-beam Section Properties

Section Property	Small	Medium	Large
$A_g$ (in <sup>2</sup> )	134	166	268.8
$I_g$ (in <sup>4</sup> )	4513	6684	15329
$e_g$ (in)	8.19	9.73	13.79
$A_{gt}$ (in <sup>2</sup> )	140.8	173.1	276.8
$I_{gt}$ (in <sup>4</sup> )	4858	7139	16344
$e_{gt}$ (in)	8.18	9.70	13.69

The three cross-sections were designed with the same dimensions in specific areas of the beams for simplicity throughout the fabrication process. Each cross-section had a web width of 4 in, an overall web height of 11 in, and a bottom flange width of 8 in. The use of the identical dimensions enabled the utilization of the same formwork with only slight modifications from



pour to pour for different beam sizes. In each cross-section, three strands were placed 2 in from the bottom of the formwork with a lateral center-to-center spacing of 2 in, which is typical in the prestressing industry.

In addition to prestressed reinforcement, longitudinal and transverse non-prestressed reinforcement was used in the top flange as well as shear reinforcement in the web and confining ties near the end of the transfer zone for each beam. Longitudinal reinforcement consisted of No. 4 bars equally spaced, located 1.125 in from the face of the top flange. The small and medium size beams each contained three longitudinal bars in the top flange, while the large size beams contained five longitudinal bars in the top flange. Transverse reinforcement consisted of No. 3 bars spaced at 18 in throughout the length of the beam, perpendicular to the longitudinal reinforcement, placed directly on top of the longitudinal reinforcement. The shear reinforcement varied among the three cross-sections and was dependent upon the nominal moment capacity of each beam, with the maximum shear force calculated under the assumption each beam would reach its full nominal moment capacity during flexural testing. As for the steel component of shear resistance, No. 3 and No. 4 single leg stirrups were used with spacings adjusted accordingly. The small size beams contained No. 4 single leg stirrups placed every 4 in over a distance of 8 ft from each end of each beam, while the middle 8 ft contained No. 3 single leg stirrups placed every 8 in. The medium size beams also contained No. 4 single leg stirrups placed every 4 in in the end portions of the beams, however, No. 4 single leg stirrups were also used in the middle portion of the beam at a spacing of 8 in for added simplicity during the fabrication process. The large size beams were capable of supporting significantly higher loads, resulting in smaller stirrup spacings. The large beams contained No. 4 single leg stirrups placed every 3 in over the end two-thirds of the beams, while the middle third contained No. 4 single leg stirrups placed every 6 in. Confining ties were also placed at each end of each beam. Three triangular ties were placed within 1 ft of the end of each beam to prevent bursting during the transfer process.

The twenty T-beam test specimens were cast in six groups, each designated by pour, from Pour 1 to Pour 6. Cross-section variations were dependent on the strand type under investigation for a specific pour and the casting orientation was used to further investigate the influence of the top-strand effect on transfer and development length of flexural members. In an effort to investigate the top-strand effect, eight of the T-beam test specimens were cast up-side-down (inverted). Casting of the test specimens with an inverted orientation resulted in more than 12 in of fresh concrete beneath the strand, which categorizes a strand as a “top-strand” based on the definition provided in ACI (ACI 318-08 Building Code Requirements for Reinforced Concrete (2008)) for top reinforcing bars. Inverted orientations of small, medium, and large size beams resulted in respective depths of concrete cast beneath the strands of 15 in, 17 in, and 22 in, while maintaining a constant depth of 2 in of concrete cast above the strand. In pours containing inverted beams, each inverted beam was cast on the same line of strands in succession with a counterpart beam having a normal orientation. This ensured a direct head-to-head comparison of beams cast with normal and inverted orientations. In addition to a head-to-head comparison, the variations in depths of concrete cast beneath the strands coupled with the constant depth of concrete cast above the strands also led to an analysis of the results with respect to reports claiming the top-strand effect to be dependent on the amount of concrete cast above the strand rather than the amount of concrete cast beneath the strand.

## Fabrication of Test Specimens

The fabrication of all test specimens was completed in the Structures and Materials Laboratory at Virginia Tech. In order to fabricate the pretensioned, prestressed concrete beams, two prestressing beds were created on a portion of the reaction floor inside the laboratory. Figure 2 shows a photograph of the prestressing bed used with format in-place and strand stressed. The test specimens were cast in a laboratory setting rather than by a precast manufacturer, however, the casting procedures typically employed in a prestressing plant were replicated. In order to fabricate beams with normal and inverted orientations along the same line of strands, the beams with a normal orientation were elevated. Figure 3 shows the plan view of a typical pour along with sections of both beam orientations.



Figure 2. Prestressing bed.

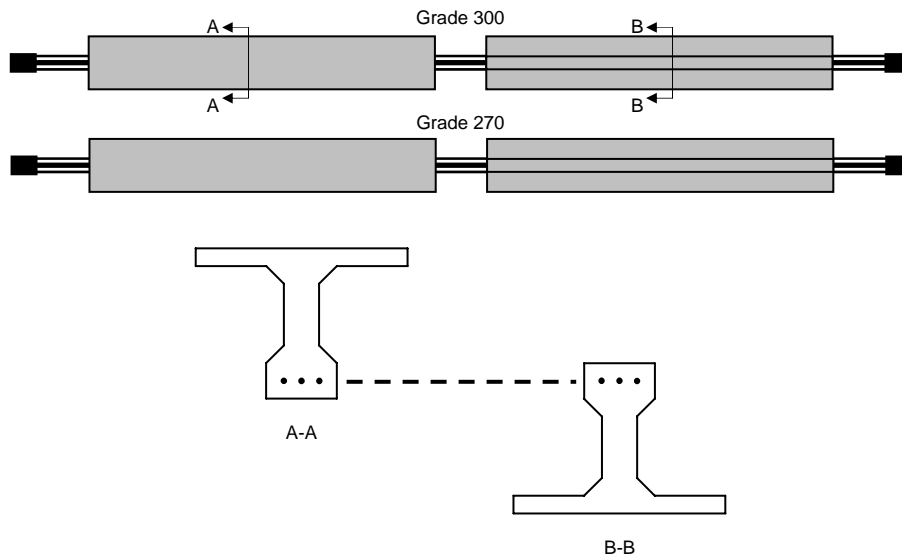

Figure 3. Plan view of typical pour layout.

## Material Properties

The concrete mixture used in the T-beam test specimens was designed to be a normal weight concrete with a target compressive strength of 4500 psi at transfer and a 28 day compressive strength of 6000 psi. The mix consisted of a ¾ in maximum aggregate, natural sand, Portland cement, fly ash, water, and various admixtures. The initial mix design, as shown in Table 3 had a water to cement ratio of 0.38 and called for the use of a super plasticizer. Following a flash set during the first pour, the initial mix design was slightly modified, also shown in Table 3, increasing the water to cement ratio to 0.40 and adding a retarding admixture. Table 4 below provides the tested materials properties for all six concrete pours.

**Table 3. Concrete Mix Proportions**

Component	Quantity (per yd <sup>3</sup> )	
	Initial	Revised
No. 78 Stone	1443 lb	1443 lb
Natural Sand	1083 lb	1083 lb
Portland Cement	600 lb	600 lb
Fly Ash	150 lb	150 lb
Water	34 gal	36 gal
Air Entrainment	3-5%	3-5%
Super Plasticizer	19 oz.	19 oz.
Retarder	None	19 oz.
W:C	0.38	0.40

**Table 4. T-beam Concrete Properties**

Pour	Final Slump (in.)	HRWR Used (oz)	f' <sub>ci</sub> (psi)	28 day f' <sub>c</sub> (psi)	f <sub>r</sub> (psi)	E <sub>c</sub> (ksi)
1	2.75	76	4900	6500	600	4600
2	7.5	NA	5300	6400	600	4500
3	6.5	NA	6000	8200	700	5100
4	7.5	NA	4900	6300	700	4600
5	6.25	NA	5000	6500	600	4600
6	11.5	128*	6400	8300	700	5200

In the prestressed concrete industry, Grade 270 low-relaxation prestressing strand has been the industry standard for decades. ASTM A416 specifies that the ultimate stress for all tests completed on a Grade 270 strand must be no less than 270 ksi. It is also specified that the minimum yield stress be no less than 90 percent of the required ultimate stress at a strain of 0.01 in/in and the ultimate elongation be at least 3.5 percent (A416-05/A416M-05 (2005)). There are currently no provisions for the Grade 300 strand; however, the ASTM limits were used as guidelines during material testing, thus the minimum required ultimate stress for a Grade 300 strand is 300 ksi, which corresponds to a minimum yield stress of 270 ksi at a strain of 0.01 in/in. The ultimate elongation limit of 3.5 percent was still used with the Grade 300 strand (Loflin 2008).

Material testing focused on a the development of the full stress/strain relationship for both the Grade 270 and Grade 300 strand used throughout this study. Table 5 shows a summary

of the results for yield stress, ultimate stress, and ultimate elongation, which were used to create stress-strain curves for each strand type, and was used in the calculation of nominal moment capacities for beams tested in flexure. The Grade 270 and Grade 300 strand properties were approximately equal to those required by ASTM, however, several of the tested properties were a few ksi below that required.

**Table 5. Summary of Material Testing Results (Loflin 2008)**

<b>Strand</b>	<b>Average Yield Stress (ksi)</b>	<b>Average Ultimate Stress (ksi)</b>	<b>Average Ultimate Elongation</b>
½ in regular GR 270	248	279	7.5%
½ in regular GR 300	270	301	7.1%
½ in regular GR 300	275	296	6.3%
½ in super GR 270	239	268	7.2%
½ in super GR 270	236	273	7.4%
½ in super GR 300	270	296	7.2%
0.6 in GR 270	242	276	7.5%

### **Transfer Length Measurements**

Transfer length measurements were taken at each end of each T-beam and each end of each top-strand block for each strand, corresponding to the live and dead end of each test specimen. The live end of the specimen was the end at which the strand was torch cut (in between two test specimens cast on the same line of strands), while the dead end of the specimen was the end at which the strand was anchored to the supporting abutments. Transfer lengths of each end of each beam were determined by measuring and plotting concrete surface strains along the beam length.

Concrete surface strains were measured using a DEMountable MEChanical (DEMEC) strain gauge and surface mounted gauge points. The DEMEC gauge had a gauge length of 7.874 in (200 mm) and the gauge points were approximately ¼ in in diameter with a small, fine point indentation located at the approximate center. These points were placed on the test specimens at the level of the strands at a spacing of 1.969 in (50 mm) and 3.937 in (100 mm). A spacing of 1.969 in was used in areas expected to be within the anticipated transfer zone, ensuring a defined ascending branch of the strain plot. The remaining points located beyond the anticipated transfer zone, corresponding to the strain plateau were spaced at 3.937 in. Each individual strain reading was based on the total gauge length of 7.874 in, so adjacent strain readings would overlap aiding in the development of a smooth strain plot. Figure 4 shows the typical layout of DEMEC points used on a T-beam specimen.

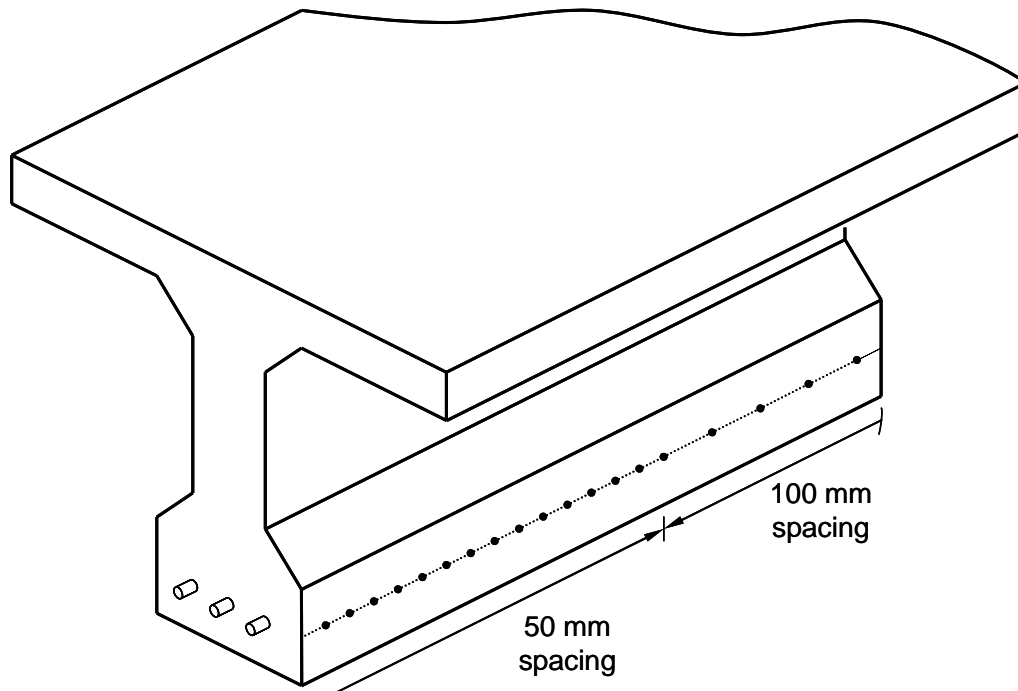

**Figure 4. T-beam DEMEC point layout.**

Subsequent to the initial readings, the strands were flame cut using an acetylene torch. The strands are not physically cut, but are gradually heated until the strands rupture in tension. For the T-beam test specimens, the middle strand was cut first followed by each of the two outer strands. This pattern of cutting was used to first apply a uniform compressive stress along the middle of the cross-section to resist any possible weak axis bending resulting from the lateral eccentricity of the outside strands. Following the transfer of prestress, the DEMEC points were again measured and recorded. The difference between the two readings (before and after transfer) at any one location provided the change in length from the point at which zero prestress force was applied to the point at which the entire prestress force was applied. The change in length was then divided by the gauge length, resulting in the average strain across the gauge length for that location. A number of researchers have shown transfer lengths to increase over time by approximately ten percent, therefore, additional measurements are usually taken. The second set of readings were taken one to two weeks after transfer.

Based on each set of concrete surface strains recorded using the DEMEC gauge, a strain profile similar to Figure 5 was created for each transfer zone and the 95 percent Average Maximum Strain (AMS) method was used with slight modifications to estimate initial and the second set of transfer lengths (Russell and Burns 1993).

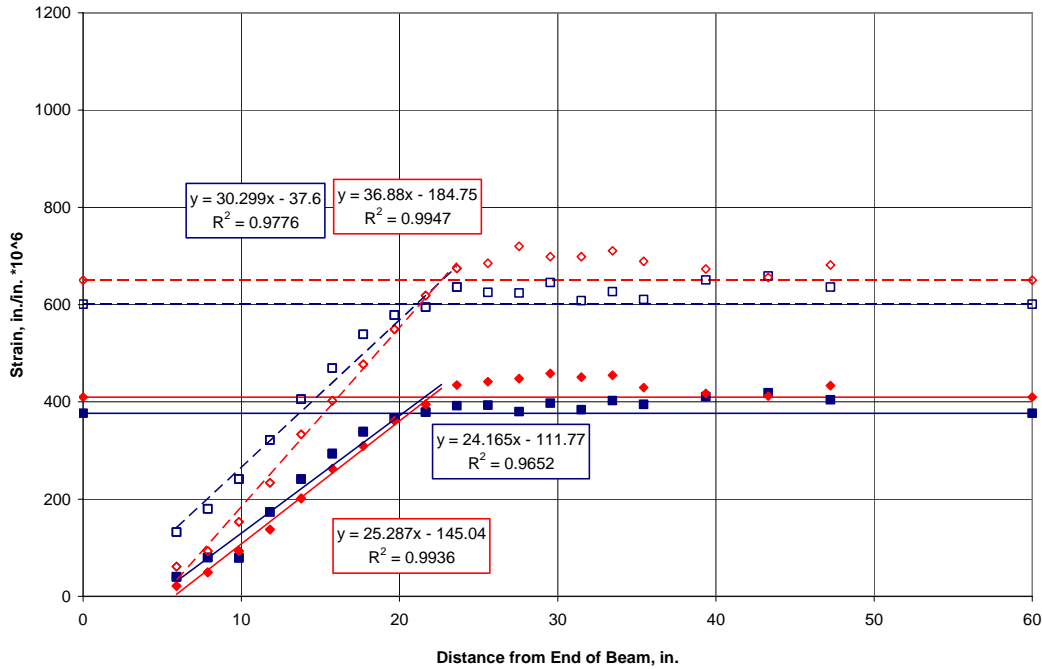

**Figure 5. Transfer length strain profile.**

### Development Length Measurements

The development length tests were designed to establish the minimum development length for each of the five strand types used. A single point bending test was performed on each end of the 24 ft long T-beam test specimens with a test span of 16 ft, allowing for two tests per beam. Figure 6 shows the test setup for one of the single point bending tests. The initial location of the point load (P) and the embedment length ( $L_e$ ) from the end of the beam were based upon the calculated development length.

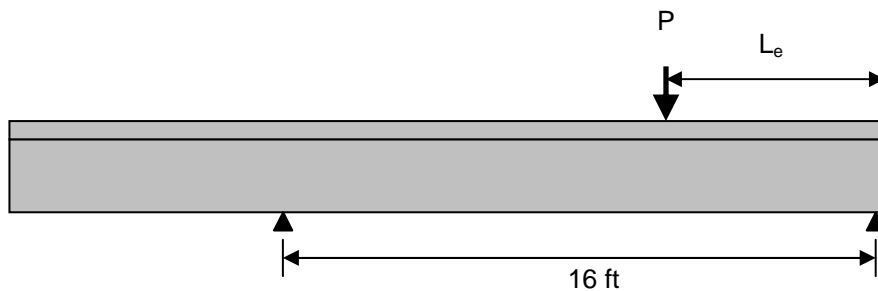

**Figure 6. Single point bending test schematic.**

With each test arose the possibility of three failure types, flexural, bond, or in some cases a combination thereof. A flexural failure is defined by either crushing the concrete in the compression zone or by rupturing the strands in very ductile test specimens, both of which are easily discernable and shown in Figure 7. Leading up to each type of failure, a test specimen will typically see very little increase in applied load with substantial increases in deflection. It should be noted that with a single point load, the concrete was confined by the load itself,

resulting in an increase in compressive strength of the concrete. A bond failure was defined by the amount of strand slip occurring at the end of the test specimen, with a limit of 0.01 in. End-slip measurements during flexural testing were measured with linear variable differential transducers (LVDT's), with an accuracy of 0.001 in. Three LVDT's were attached to the end of the test specimen corresponding to the embedment length in question, mounted with a small frame constructed of small aluminum channel as shown in Figure 8. In most cases, a full bond failure would allow the strand to pull into the end of the test specimen, pulling away from the tip of the LVDT's.

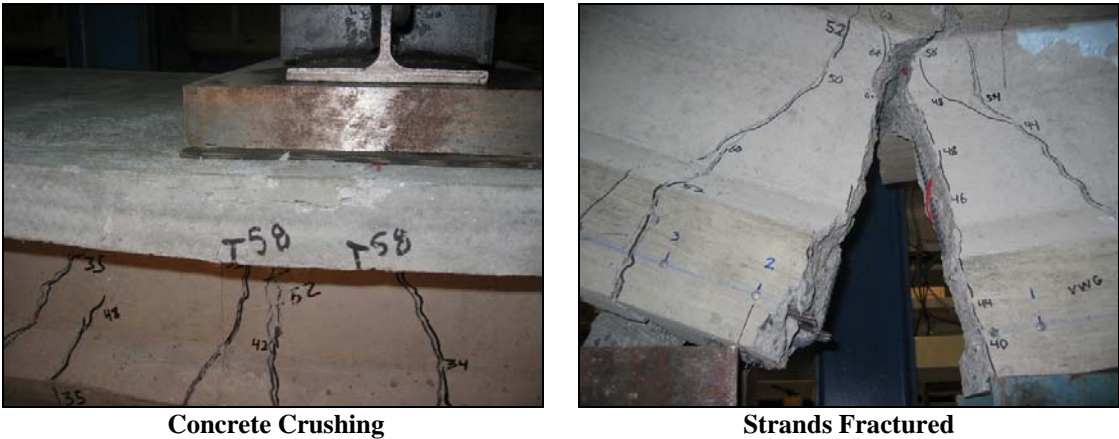

Figure 7. Flexural failures.

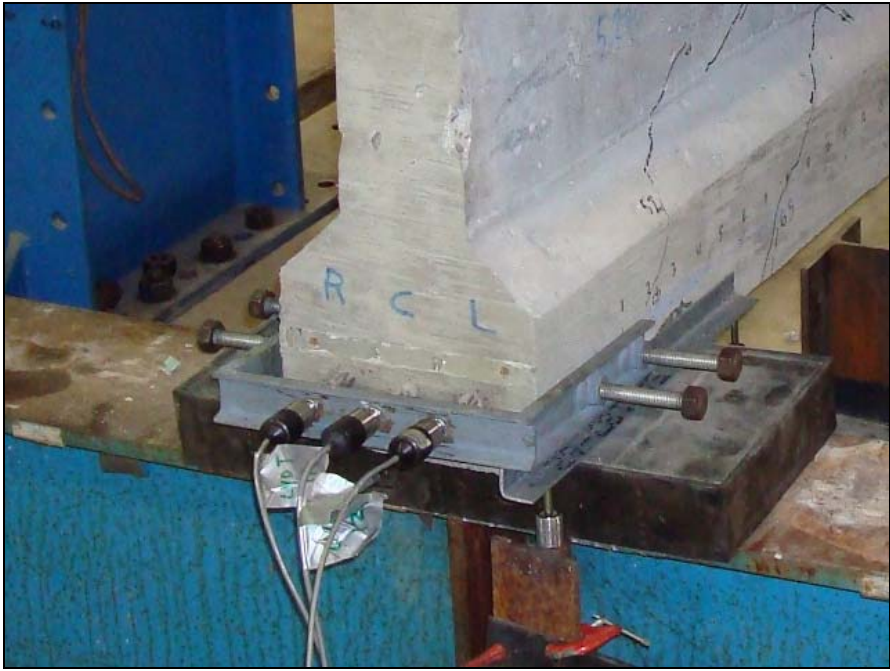

Figure 8. End-slip measurement setup.

The application of load during the single point bending tests was conducted in 2 kip increments until cracking, then 5 kip increments thereafter. During the single point bending tests, a flexural failure would indicate that the selected embedment length was longer than the

actual development length, in which case the succeeding test of a new specimen would incorporate a shorter embedment length. A test resulting in a bond failure, an average slip of the three strands of 0.01 in or greater, would indicate that the selected embedment length was shorter than the actual development length, in which case the succeeding test of a new specimen would incorporate a larger embedment length. This process was repeated for each strand type with the intention of determining the minimum flexural bond length to result in a flexural failure. Upon the completion of each test, the flexural bond length was taken as the tested embedment length minus the corresponding transfer length.

### Flexural Strength

The flexural strength, also referred to as the nominal moment capacity and ultimate flexural capacity, was determined experimentally by single point bending tests used in the determination of the development length as well as theoretically based on the provisions of ACI (ACI 318-08 Building Code Requirements for Reinforced Concrete (2008) and AASHTO (AASHTO LRFD Bridge Design Specifications, Fourth Edition (2007)) and strain compatibility. The flexural strength was determined experimentally for each test specimen assuming the strand was fully developed. When calculating the nominal flexural capacity of a section using the ACI or AASHTO provisions, the assumption of perfect bond between the strand and surrounding concrete is made, although that may not be true in every situation. Therefore, the value obtained by ACI or AASHTO provisions for each test specimen is the maximum nominal moment capacity. Strain compatibility also makes the assumption of perfect bond and will also result in a maximum nominal moment capacity, slightly higher than that calculated by ACI or AASHTO. The application of load used in the single point bending tests added a confinement in the compression zone of the test specimen, resulting in an increase in compressive strength of the concrete. Taking this confinement into consideration, the calculated nominal moment capacities based on strain compatibility used a concrete stress-strain relationship as shown in Figure 9.

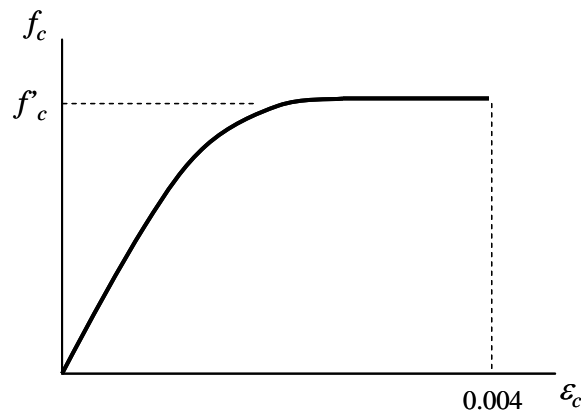

Figure 9. Modified confined concrete stress vs. strain diagram.

In addition to the monitoring of end-slip during flexural testing, the applied load and deflection directly under the load point were measured. The applied load was measured using a strain gauge type load cell having a precision of approximately 100 lb, while the deflection was determined using a single wire pot, with a precision of approximately 0.001 in. The support



conditions were assumed to be simply supported using neoprene bearing pads at each end of the beam, typically used in industry, which incur a small amount of displacement under the applied load as well as some rotation as a result of vertical deflection in the beam during loading. In order to take into consideration the vertical displacement and displacement from rotation in the pad, large scale LVDT's were used to monitor the support displacements. Some concern was raised about the possibility of the neoprene bearing pads supplying horizontal restraint to the beam creating an arching action rather than a truly simply supported condition. Therefore, an independent study was conducted on the support conditions of simply supported flexural tests, which showed no significant differences in the flexural capacity of rectangular beams supported with neoprene bearing pads versus a traditional pin and roller support system.

## **RESULTS AND DISCUSSION**

### **Transfer Length**

Transfer lengths were determined for 39 transfer zones from the T-beam test specimens using measurements of concrete surface strains at the time of transfer and one to two weeks thereafter. For consistency, transfer lengths taken at the time of transfer were used in comparisons unless otherwise noted, since the time of the second measurements varied with each set of test specimens. The T-beam test specimens account for 39 transfer zones (20 Dead End, 19 Live End).

Historically, transfer length has been shown to be affected by a number of contributing factors such as method of release, strand diameter, effective prestress, concrete strength, strand surface conditions, time, and as-cast vertical location. The influence of a number of these factors were evaluated. The influence of release method was first looked at, comparing the measured transfer lengths of ends adjacent to flame cutting (Live End) to those adjacent to support abutments (Dead End). The effect of strand strength was compared in a similar manner as was casting orientation for the transfer lengths associated with the T-beam test specimens and the effect of time as initial and second sets of measurements were compared for all transfer zones.

In addition to the factors affecting transfer length, transfer length measurements were compared to the current code provisions from ACI and AASHTO. The values of effective and initial prestress used in the comparisons were determined by subtracting the amount of prestress losses calculated by current AASHTO provisions. Historically, ACI and AASHTO have only included effective prestress and the strand diameter in the calculation of transfer lengths.

### **Overview of Transfer Length Results**

A number of researchers have shown transfer lengths of strands released by and adjacent to a flame cutting process to be longer with respect to those located away from the flame cutting process or adjacent to support abutments. This increase is important in the development of transfer length equations. In the past, some equations have been derived based on a gradual release method, while the standard method of release used in the prestressing industry is

typically the flame cutting process. Thus, the influence of release method is vital in the evaluation of transfer length results. The transfer length results are shown in Table 6 for the T-beam test specimens. The beam identification scheme designates pour number (1 to 6), strand grade (270 or 300), strand size [1/2 in (5N), 1/2 in special (5S), and 0.6 in (6N)], and casting orientation [R (right side up) and U (up side down)].

The average increase of transfer lengths at the live ends versus transfer lengths at the dead ends for the T-beam test specimens cast with a normal orientation was 45 percent, while those cast with an inverted orientation increased by 49 percent. Note that transfer lengths for members 2.300.5N.U and 2.300.5S.U, both containing Grade 300 prestressing strands and cast with an inverted orientation, increased by 84 and 95 percent, respectively. There is a possibility these long values were influenced by the high levels of bleed water, as transfer lengths have been shown to increase with highly fluid mixes. This only occurred with the beams containing Grade 300 strands and may be a result of the larger prestress force coupled with a mix of high fluidity. There was speculation that inadequate consolidation of the concrete around the strand may have caused these relatively long transfer lengths. For verification purposes, autopsies were performed on beams from Pour 1 and Pour 2 to compare the interface between the prestressing steel and surrounding concrete. No differences were observed between the concrete around the strands following the autopsies, therefore, it was concluded that the concrete surrounding the strands had adequate consolidation. Since high levels of bleed water can occur in routine production of prestressed members, these long transfer lengths can occur in normal prestressed concrete production situations.

**Table 6. Influence of Release Method (T-beam Test Specimens)**

	Beam	$f_{sj}$	$f_{si}$	$f_{se}$	$f'_{ci}$	$f'_c$	Transfer Length (in.)		
		ksi	ksi	ksi	psi	psi	Live	Dead	Live/Dead
Normal	1.270.5N.R	180.9	168.4	157.0	4900	6500	16.7	12.3	1.36
	2.270.5N.R	180.9	168.4	162.3	5300	6400	18.1	12.5	1.46
	3.270.5S.R	180.9	169.1	158.6	6000	8200	21.1	13.6	1.55
	4.270.5S.R	180.9	168.3	157.8	4900	6300	17.5	15.5	1.13
	5.270.5S.R	202.5	187.5	162.5	5000	6500	20.2	12.8	1.58
	6.270.5S.R	202.5	188.8	174.3	6400	8300	20.7	16.7	1.24
	1.300.5N.R	201.0	186.9	175.8	4900	6500	NA	14.6	NA
	2.300.5N.R	201.0	187.0	180.0	5300	6400	21.2	14.2	1.50
	3.300.5S.R	201.0	187.7	176.2	6000	8200	20.8	13.5	1.53
	4.300.5S.R	201.0	186.9	175.5	4900	6300	18.4	14.1	1.30
	5.300.5S.R	225.0	208.1	181.2	5000	6500	20.6	13.9	1.47
	6.270.6N.R	202.5	188.4	173.0	6400	8300	19.3	10.7	1.80
<b>Average Increase</b>									<b>1.45</b>
Inverted	2.270.5N.U	180.9	168.4	161.7	5300	6400	30.2	24.5	1.23
	3.270.5S.U	180.9	169.1	157.5	6000	8200	25.6	19.8	1.29
	5.270.5S.U	202.5	187.5	162.4	5000	6500	26.3	19.9	1.32
	6.270.5S.U	202.5	188.8	173.6	6400	8300	21.3	17.8	1.20
	2.300.5N.U	201.0	187.0	179.3	5300	6400	43.3	23.6	1.84
	3.300.5S.U	201.0	187.7	175.1	6000	8200	41.1	21.1	1.95
	5.300.5S.U	225.0	208.1	180.9	5000	6500	24.3	19.2	1.27
	6.270.6N.U	202.5	188.4	172.4	6400	8300	23.1	12.9	1.79
<b>Average Increase</b>									<b>1.49</b>

In addition to the tabulated values, Figure 10 also shows the relationship of transfer lengths at the live end of a test specimen compared to the transfer lengths at the dead end of a test specimen with transfer lengths measured in strand diameters. Again, a general increase is shown for all T-beam test specimens with the largest differences in live and dead end measurements shown in the inverted beams. All live and dead end transfer lengths for beams cast with a normal orientation fall below current code provisions of ACI and AASHTO,  $50d_b$ ,  $f_{se}/3$ , and  $60d_b$ , and although all of the dead end transfer lengths of the inverted beams fall below code values, five live end transfer lengths exceeded the  $50d_b$  value from ACI, three of which exceeded the  $60d_b$  value from AASHTO. These longer transfer lengths could prove problematic in the design for shear in prestressed concrete members.

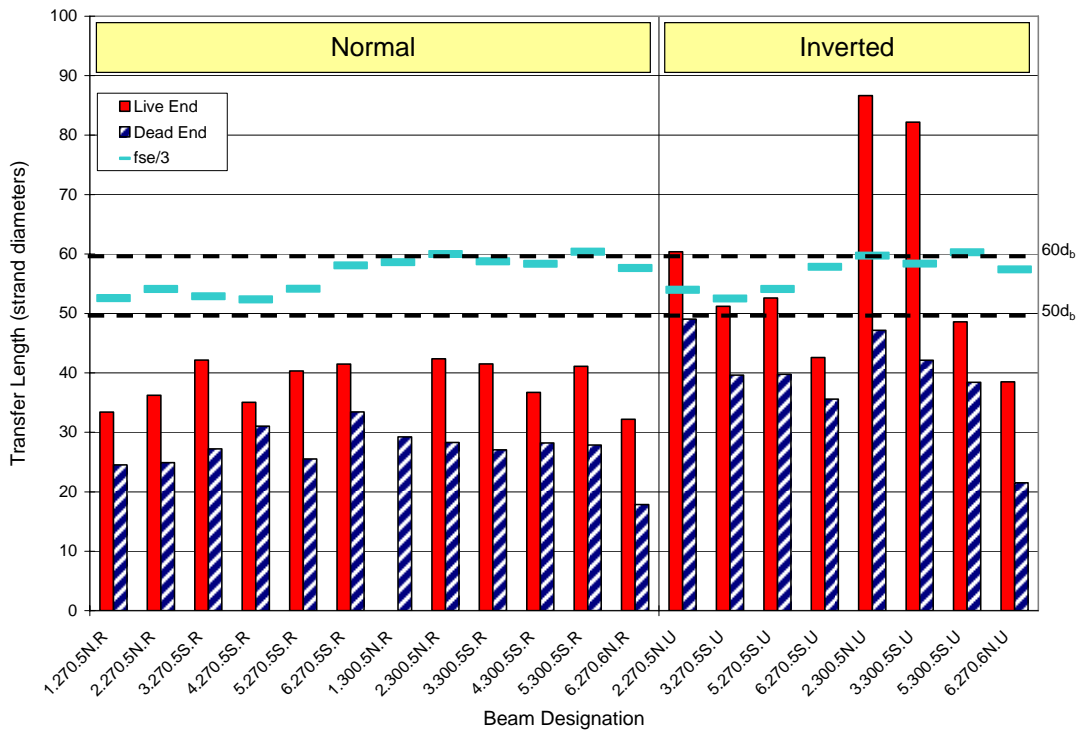

Figure 10. Influence of release method on transfer length (T-beams).

In summary, transfer lengths of Grade 270 and 300 strand in normal oriented beams were less than ACI and AASHTO requirements, however, this was not true for the inverted beams. Inverted specimens with both Grade 270 and 300 strand exceeded ACI or AASHTO criteria for transfer length. This indicates that further study of the top strand effect of both Grade 270 and 300 strand is warranted. Also, the comparison of transfer lengths for live and dead ends was in agreement with previous research. An average overall increase in transfer length of 22 percent was seen between live and dead ends, showing the necessity of measurements taken adjacent to the ends of test specimens having a sudden release to be incorporated in the development of transfer length equations.

## Strand Strength and Transfer Length

As with the influence of release method on transfer length, it was believed that an increase in strand strength, which resulted in larger effective prestress values, would also result in an increase in transfer lengths. Grade 300 strand allows for an 11 percent increase in initial prestress as compared to the traditional Grade 270 strand, which was expected to increase transfer lengths. Table 7 lists the transfer lengths of both the Grade 300 and Grade 270 strands also giving ratios of the results for each. It should be noted that Pour 6 did not include Grade 300 strands, but used Grade 270, 0.6 in diameter strands instead and was not included in average calculations. The average increase of transfer lengths for Grade 300 strands versus Grade 270 strands of the T-beam test specimens cast with a normal orientation was 6 percent for both the live and dead ends. The average increase of transfer lengths for Grade 300 strands versus Grade 270 strand of the T-beams cast with an inverted orientation was 32 percent at the live ends, but failed to show an increase at the dead ends. Note that increases of 43 percent and 61 percent were seen in Pour 2 and Pour 3 for the inverted beams. As was discussed in the previous section, it is unknown as to the cause of this behavior, but is believed to be a combination of an increase in strand strength coupled with the fluidity of the concrete mix.

**Table 7. Influence of Strand Strength**

	Pour			Transfer Length (in.)				Ratios	
		f' <sub>ci</sub>	f' <sub>c</sub>	Live		Dead		Live	Dead
		psi	psi	300	270	300	270	300/270	300/270
Normal	1	4900	6500	NA	16.7	14.6	12.3	NA	1.19
	2	5300	6400	21.2	18.1	14.2	12.5	1.17	1.14
	3	6000	8200	20.8	21.1	13.5	13.6	0.98	0.99
	4	4900	6300	18.4	17.5	14.1	15.5	1.05	0.91
	5	5000	6500	20.6	20.2	13.9	12.8	1.02	1.09
	6	6400	8300	19.3	20.7	10.7	16.7	0.93	0.64
	<b>Average Increase</b>							<b>1.05</b>	<b>1.06</b>
Inverted	2	5300	6400	43.3	30.2	23.6	24.5	1.43	0.96
	3	6000	8200	41.1	25.6	21.1	19.8	1.61	1.06
	5	5000	6500	24.3	26.3	19.2	19.9	0.92	0.97
	6	6400	8300	23.1	21.3	12.9	17.8	1.08	0.73
		<b>Average Increase</b>							<b>1.32</b>

In conjunction with Table 7, Figures 11 and 12 show the comparison of transfer lengths, in strand diameters, for the T-beam test specimens cast with a normal and inverted orientation, respectively. The transfer lengths shown in Figure 11 all fall below both ACI and AASHTO values, with transfer lengths of Grade 300 strands having slightly larger values. Contrary to the transfer length of the T-beam test specimens cast with a normal orientation, five of the transfer lengths for the T-beam test specimens cast with an inverted orientation exceeded the ACI provision of  $50d_b$ , three of which exceeded the AASHTO provision of  $60d_b$ . As previously mentioned, the live end transfer lengths of the Grade 300 strand in Pour 2 and Pour 3 far exceed other measurements as well as code provisions. As shown on Figures 11 and 12, Pours 1 through 4 used a jacking stress of  $0.67f_{pu}$ , while Pours 5 and 6 used a jacking stress of  $0.75f_{pu}$ . It is reasonable to predict that if the Grade 300 strands used in Pour 2 and Pour 3 were initially stressed to  $0.75f_{pu}$ , the transfer lengths could have very well been  $97d_b$  and  $92d_b$ , respectively, by multiplying the original values by the ratio of initial prestresses.

Overall, an average increase of 10 percent was shown for all transfer lengths of Grade 300 strand compared to transfer lengths of the Grade 270 strand. For T-beam test specimens cast with a normal orientation, all measured values fell below current code provisions however for T-beam test specimens cast with an inverted orientation, some of the measured transfer lengths exceeded the current code provisions, in the predicted cases of Pours 2 and 3, by almost 95 percent. Thus, results have shown strands cast near the as-cast top of the test specimen to exhibit longer transfer lengths regardless of strand grade or beam end.

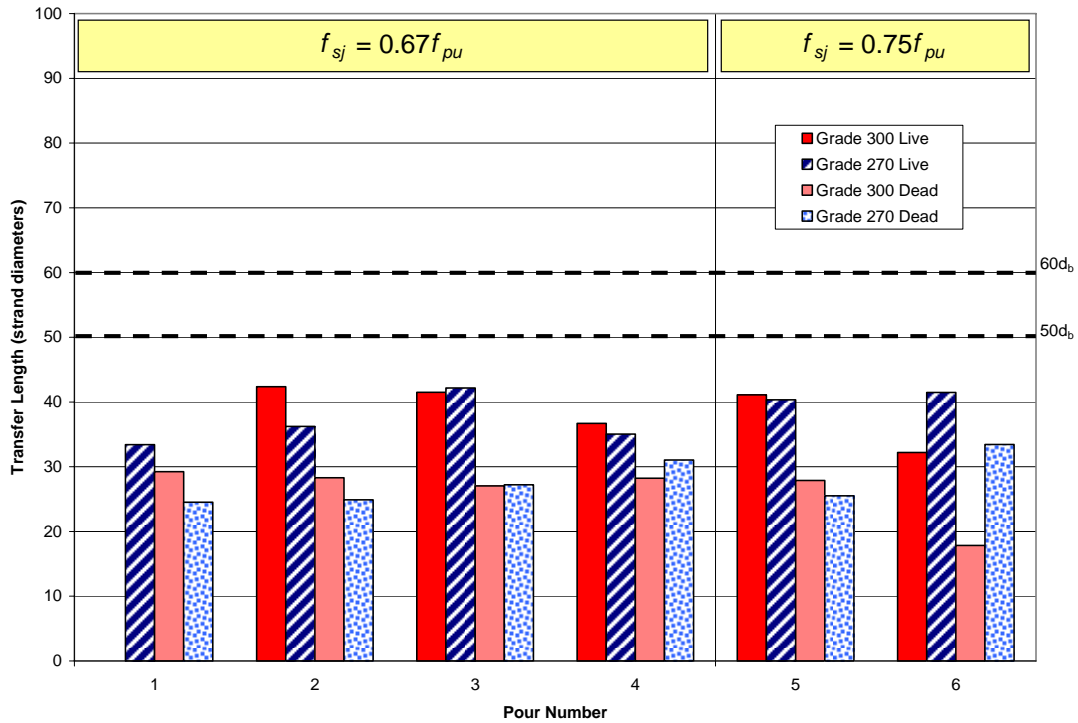

Figure 11. Influence of strand grade (T-beams – normal orientation).

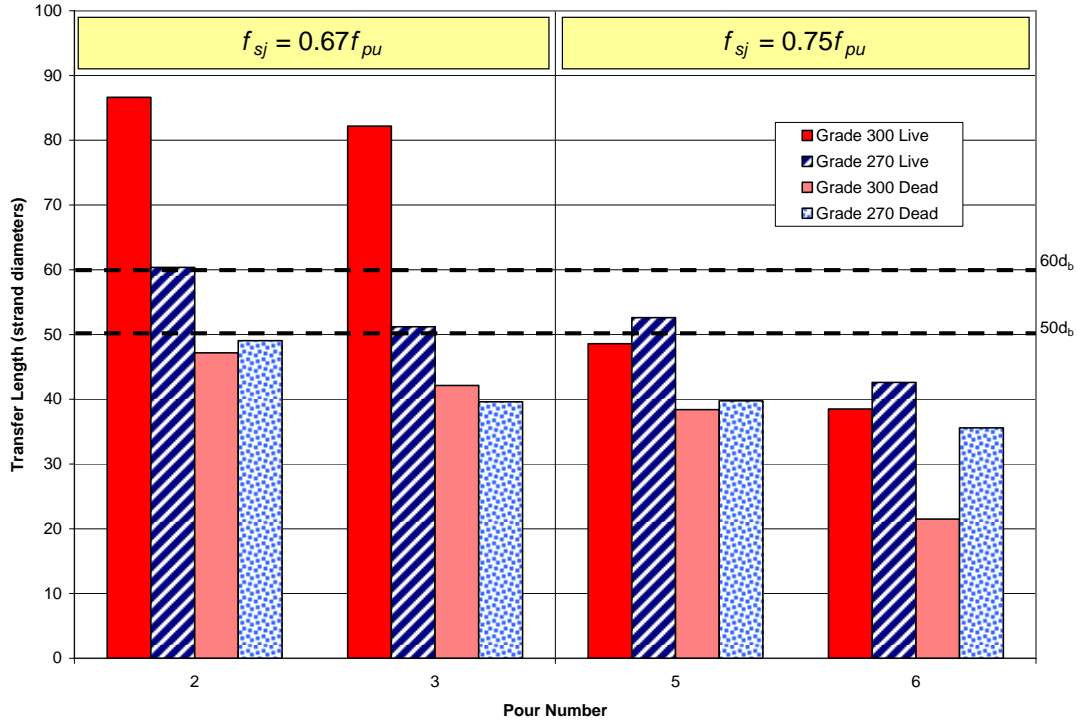
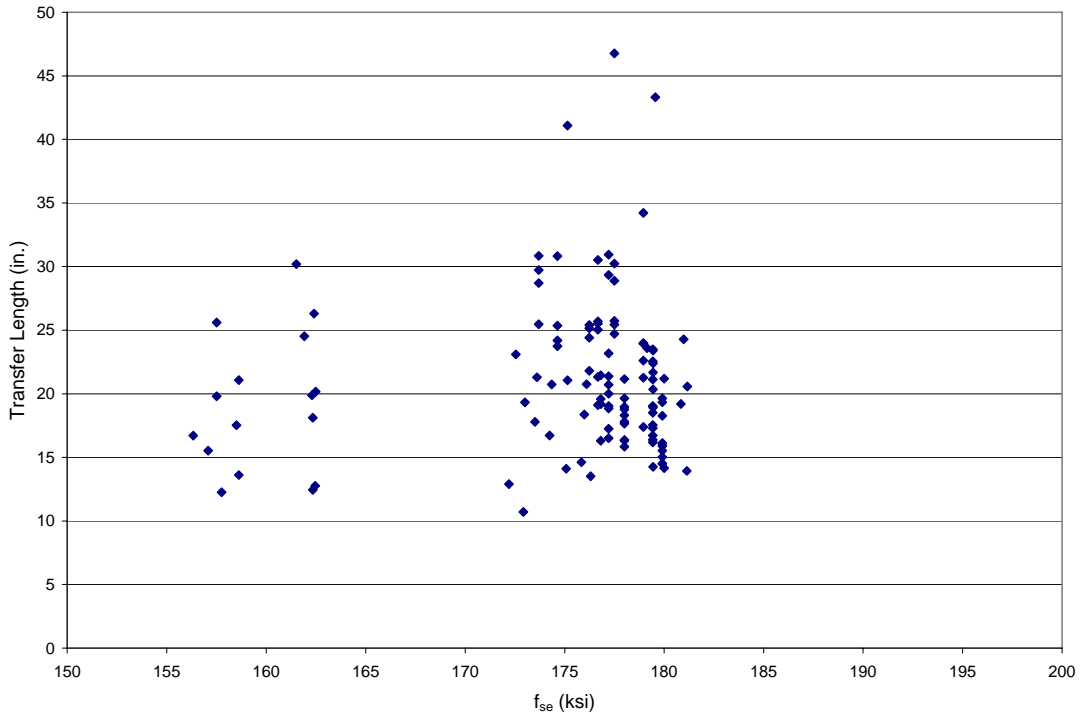

Figure 12. Influence of strand grade (T-beams – inverted orientation).

### Effective Prestress and Transfer Length

The effective prestress  $f_{se}$  (stress in the strand after all losses) has been used in the calculation of transfer length since the implementation of Equation (2-2) in the ACI Building Code, however, research over the past few decades has shown transfer lengths to be more dependent on the initial prestress  $f_{si}$  (stress in the strand just after transfer) rather than the effective prestress. In retrospect, using the initial prestress in place of the effective prestress seems more logical, since the initial prestress is the stress in the strand transferred to the surrounding concrete. In either case, a number of researchers have shown transfer length to increase with effective and initial prestress. For that reason, two levels of prestress were used in this study,  $0.67f_{pu}$  and  $0.75f_{pu}$ . Figure 13 shows the relationship between the effective prestress and transfer length while Figure 14 shows the relationship between the initial prestress and transfer length. In either case, a significant amount of scatter exists, failing to produce any definitive trends relating transfer length to effective or initial prestress. However, transfer lengths have shown a significant tendency to increase with increased levels of prestress in past research. It is believed that a larger difference in initial and effective prestress would yield a more discernable relationship.



**Figure 13. Influence of effective prestress.**

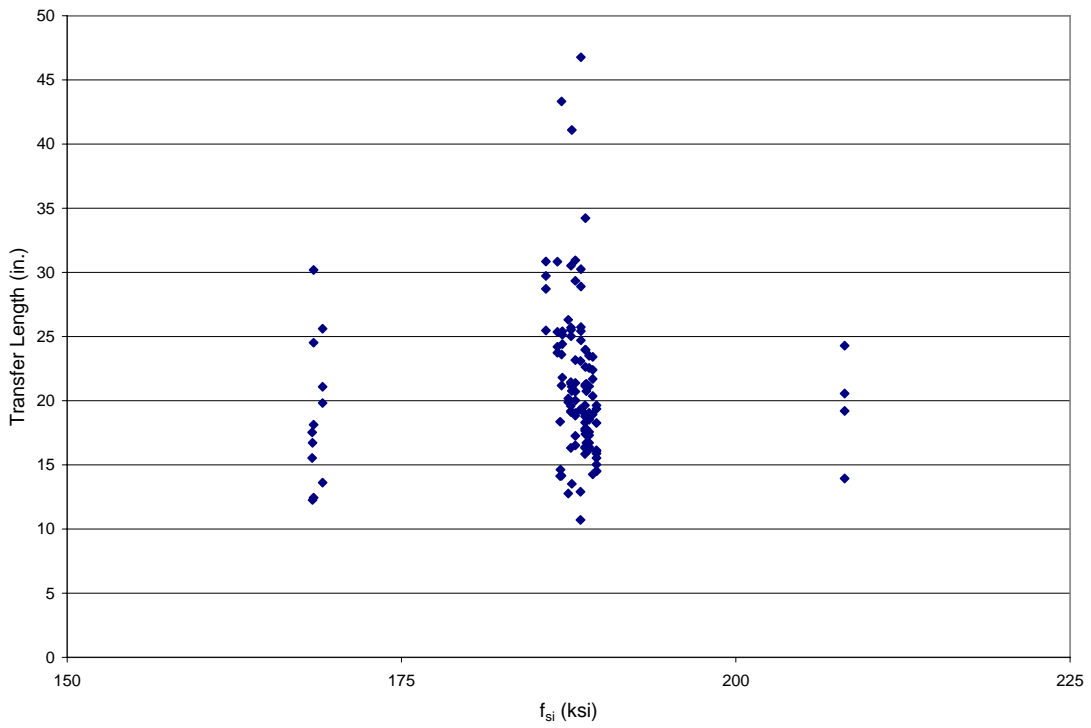

**Figure 14. Influence of initial prestress.**

## Concrete Strength and Transfer Length

Although the current code provisions do not account for the strength of concrete, research has shown an increase in concrete strength reduces transfer length, especially those in excess of 10,000 psi. Of the equations proposed by various researchers over the past few decades, the majority incorporate the concrete strength at transfer or the square root of the concrete strength at transfer in the denominator of each equation. Among the 10 sets of test specimens cast in this study, eight different concrete strengths existed at the time of transfer as shown in Table 8. The concrete strengths ranged from 4800 psi to 6400 psi. In comparison to the achievable concrete strengths, this range is somewhat small, but was still considered in the evaluation of factors influencing transfer lengths.

Average transfer lengths ranged from 14.1 in to 28.2 in with standard deviations as high as 9.8 in. Table 7 lists the average transfer length for each concrete strength at the live end, the dead end, and both ends combined. The standard deviations as well as the maximum and minimum values are also listed showing the level of variability in the measurements. In conjunction with Table 8, Figure 15 plots each transfer length measurement against the square root of each corresponding concrete strength. The data shows a significant amount of scatter, but does show a slight trend of decreasing transfer length with an increase in concrete strength at transfer. As previously noted, the range of concrete strengths was very small, but considered typical with respect to those used in the bridge industry therefore the effect of high strength concretes was not investigated in this study.

**Table 8. Influence of Concrete Strength**

		Transfer Lengths (in.)							
		Concrete Strength (psi)							
		4800	4900	5000	5300	5700	6000	6100	6400
<b>Live</b>	AVE	22.6	17.5	24.5	28.2	19.6	27.1	22.0	21.1
	STDEV	3.5	0.7	3.9	9.8	2.6	8.3	2.6	1.4
	MAX	28.9	18.4	30.5	43.3	23.4	41.1	25.4	23.1
	MIN	18.3	16.7	18.8	18.1	15.0	20.8	17.6	19.3
<b>Dead</b>	AVE	24.1	14.1	21.0	18.7	16.6	17.0	20.9	14.5
	STDEV	9.3	1.2	5.4	5.4	2.1	3.5	5.3	2.9
	MAX	46.8	15.5	30.9	24.5	20.4	21.1	34.2	17.8
	MIN	15.8	12.3	12.8	12.5	14.3	13.5	16.2	10.7
<b>Total</b>	AVE	23.3	15.6	22.7	23.4	18.1	22.1	21.5	17.8
	STDEV	7.1	2.0	5.0	9.2	2.8	8.1	4.2	4.0
	MAX	46.8	18.4	30.9	43.3	23.4	41.1	34.2	23.1
	MIN	15.8	12.3	12.8	12.5	14.3	13.5	16.2	10.7



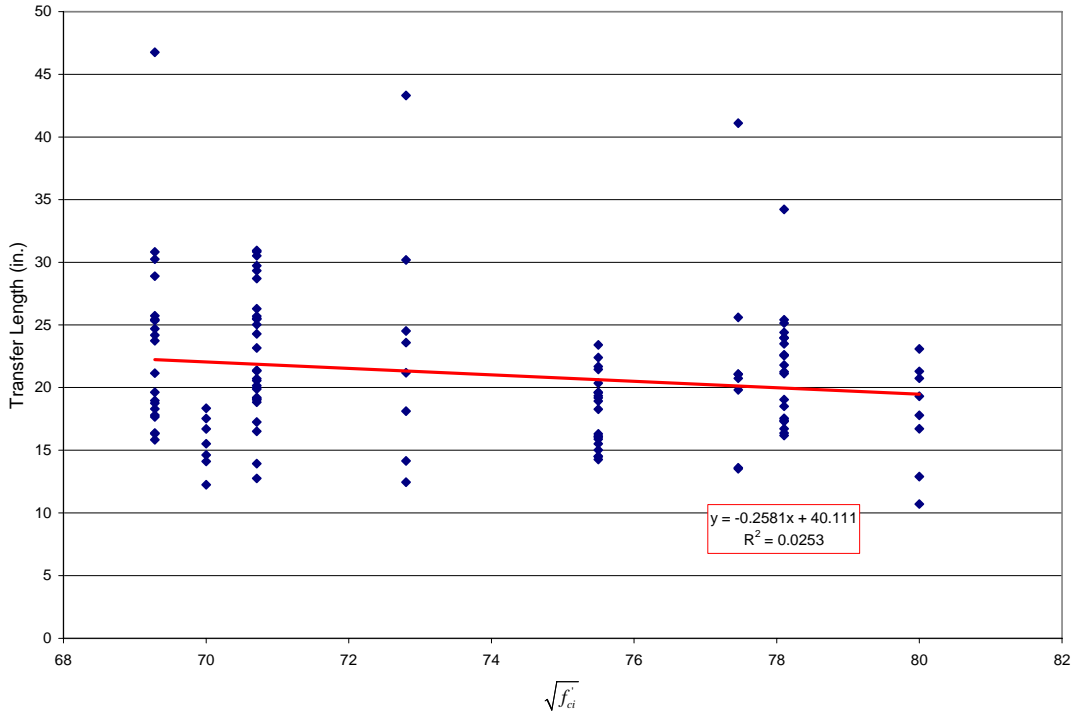

**Figure 15. Influence of concrete strength.**

### **Influence of Time**

As with strand diameter, effective prestress, and method of release, transfer lengths have also been shown to increase with time, usually occurring within the first few weeks following transfer. Transfer length measurements in this study were taken at the time of transfer and one to two weeks thereafter. Table 9 lists the initial and succeeding, or last, transfer length measurements for the T-beam test specimens along with ratios of the last to initial measurements. Transfer lengths at the live ends of the T-beam test specimens with both normal and inverted casting orientations showed an average increase of 4 percent, while the transfer lengths at the dead ends of the T-beam test specimens with normal and inverted casting orientations showed an average increase of 13 and 11 percent, respectively, while the overall average increase of initial to last transfer length measurements was 8 percent.

### **Casting Orientation and Transfer Length**

The influence of the top-bar effect has seldom been investigated in prestressed concrete, but has been an area of concern in reinforced concrete. As defined in the current ACI and AASHTO codes, the top-bar effect has been thought to be dependent on the amount of concrete cast beneath the bar. In the case of prestressed concrete, it was also expected to be dependent on the amount of concrete cast beneath the strand. Initially a secondary objective of the project, the top-strand effect was investigated by casting eight of the twenty T-beam test specimens with an inverted orientation. Table 10 lists the transfer lengths of each beam cast with a normal orientation and adjacent inverted beam as well as comparative ratios.

**Table 9. Influence of Time (T-beams)**

	Beam	fsj	fsi	fse	f'ci	f'c	Transfer Length (in.)			
		ksi	ksi	ksi	psi	psi	Initial	Last	L/I	
Normal	Live	1.270.5N.RA	180.9	168.4	156.3	4900	6500	16.7	17.4	1.04
		2.270.5N.RA	180.9	168.4	162.3	5300	6400	18.1	19.3	1.06
		3.270.5S.RA	180.9	169.1	158.6	6000	8200	21.1	21.9	1.04
		4.270.5S.RA	180.9	168.3	158.5	4900	6300	17.5	18.3	1.04
		5.270.5S.RA	202.5	187.5	162.5	5000	6500	20.2	21.3	1.06
		6.270.5S.RA	202.5	188.8	174.4	6400	8300	20.7	21.2	1.02
		1.300.5N.RA	NA	NA	NA	NA	NA	NA	NA	NA
		2.300.5N.RA	201.0	187.0	180.0	5300	6400	21.2	21.5	1.02
		3.300.5S.RA	201.0	187.7	176.1	6000	8200	20.8	21.2	1.02
		4.300.5S.RA	201.0	186.9	176.0	4900	6300	18.4	19.9	1.08
	5.300.5S.RA	225.0	208.1	181.2	5000	6500	20.6	21.9	1.07	
	6.270.6N.RA	202.5	188.4	173.0	6400	8300	19.3	19.3	1.00	
	<b>Average Increase</b>									<b>1.04</b>
	Dead	1.270.5N.RB	180.9	168.4	157.8	4900	6500	12.3	13.3	1.08
		2.270.5N.RB	180.9	168.4	162.3	5300	6400	12.5	12.7	1.02
		3.270.5S.RB	180.9	169.1	158.6	6000	8200	13.6	14.5	1.06
		4.270.5S.RB	180.9	168.3	157.1	4900	6300	15.5	18.3	1.18
		5.270.5S.RB	202.5	187.5	162.5	5000	6500	12.8	15.2	1.19
		6.270.5S.RB	202.5	188.8	174.2	6400	8300	16.7	18.2	1.09
1.300.5N.RB		201.0	186.9	175.8	4900	6500	14.6	15.9	1.09	
2.300.5N.RB		201.0	187.0	180.0	5300	6400	14.2	15.4	1.09	
3.300.5S.RB		201.0	187.7	176.3	6000	8200	13.5	14.6	1.08	
4.300.5S.RB		201.0	186.9	175.1	4900	6300	14.1	16.3	1.15	
5.300.5S.RB	225.0	208.1	181.1	5000	6500	13.9	17.1	1.23		
6.270.6N.RB	202.5	188.4	172.9	6400	8300	10.7	14.4	1.35		
<b>Average Increase</b>									<b>1.13</b>	
Inverted	Live	2.270.5N.UA	180.9	168.4	161.5	5300	6400	30.2	30.1	1.00
		3.270.5S.UA	180.9	169.1	157.5	6000	8200	25.6	28.2	1.10
		5.270.5S.UA	202.5	187.5	162.4	5000	6500	26.3	28.0	1.06
		6.270.5S.UA	202.5	188.8	173.6	6400	8300	21.3	21.5	1.01
		2.300.5N.UA	201.0	187.0	179.6	5300	6400	43.3	44.1	1.02
		3.300.5S.UA	201.0	187.7	175.1	6000	8200	41.1	43.0	1.05
		5.300.5S.UA	225.0	208.1	181.0	5000	6500	24.3	25.4	1.05
	6.270.6N.UA	202.5	188.4	172.5	6400	8300	23.1	24.0	1.04	
	<b>Average Increase</b>									<b>1.04</b>
	Dead	2.270.5N.UB	180.9	168.4	161.9	5300	6400	24.5	26.1	1.07
		3.270.5S.UB	180.9	169.1	157.5	6000	8200	19.8	23.0	1.16
		5.270.5S.UB	202.5	187.5	162.3	5000	6500	19.9	21.3	1.07
		6.270.5S.UB	202.5	188.8	173.5	6400	8300	17.8	17.8	1.00
		2.300.5N.UB	201.0	187.0	179.1	5300	6400	23.6	24.8	1.05
3.300.5S.UB		201.0	187.7	175.1	6000	8200	21.1	25.5	1.21	
5.300.5S.UB		225.0	208.1	180.8	5000	6500	19.2	20.8	1.08	
6.270.6N.UB	202.5	188.4	172.2	6400	8300	12.9	15.7	1.21		
<b>Average Increase</b>									<b>1.11</b>	

The average increase in transfer length at the live end of beams cast with an inverted orientation and an initial prestress of  $0.67f_{pu}$  was 73 percent, while the average increase in transfer length at the dead end was 67 percent. For beams cast with an initial prestress of  $0.75f_{pu}$ , the average increase in transfer length at the live and dead ends was 18 and 30 percent, respectively. It should be noted that the significant increase in transfer length for the beams cast with an initial prestress of  $0.67f_{pu}$  may be attributed to the high fluidity of the mixes used in Pour 2 and Pour 3. However, regardless of consistency, it is evident that the casting orientation of the T-beam test specimens was highly influential on transfer length measurements.

**Table 10. Influence of Casting Orientation**

	Beam			Transfer Length (in.)				Ratios	
		$f'_{ci}$	$f'_c$	Live		Dead		Live	Dead
		psi	psi	Normal	Inverted	Normal	Inverted	Inv/Nor	Inv/Nor
$0.67f_{pu}$	2.270.5N	5300	6400	18.12	30.19	12.45	24.52	1.67	1.97
	2.300.5N	5300	6400	21.18	43.32	14.15	23.59	2.05	1.67
	3.270.5S	6000	8200	21.08	25.60	13.61	19.81	1.21	1.46
	3.300.5S	6000	8200	20.75	41.09	13.52	21.07	1.98	1.56
	<b>Average Increase</b>							<b>1.73</b>	<b>1.66</b>
$0.75f_{pu}$	5.270.5S	5000	6500	20.17	26.30	12.76	19.88	1.30	1.56
	5.300.5S	5000	6500	20.56	24.29	13.94	19.20	1.18	1.38
	6.270.5S	6400	6400	20.74	21.30	16.72	17.79	1.03	1.06
	6.270.6N	6400	6400	19.32	23.09	10.71	12.90	1.20	1.20
	<b>Average Increase</b>							<b>1.18</b>	<b>1.30</b>

### Development Length

The development length of standard reinforcing bars is simply the embedment length in concrete required to fully develop the yield stress of the steel, while the development length of prestressing strand consists of two components, transfer length and flexural bond length. As previously discussed, transfer length is the distance required to transfer the effective prestress from the prestressing strand to the concrete. The flexural bond length is the additional distance required to effectively increase the stress in the strand from the effective stress to the stress at the nominal moment capacity. Analogous to transfer length, research has shown flexural bond length to also be affected by various contributing factors, such as the required increase in the strand stress, the strand diameter, the concrete strength, and as-cast vertical location. As were relevant to the determination of and comparison of flexural bond lengths, the influence of these factors were evaluated.

In order to determine the minimum embedment length required to fully develop each strand type, single-point bending tests were performed on 39 T-beam test specimens, each test resulting in one of three types of failure: flexural, hybrid, or bond. A flexural failure was defined as a beam exceeding the nominal moment capacity calculated by AASHTO provisions with less than 0.01 in of average end-slip. A hybrid failure was defined as a beam with more than 0.01 in of average end-slip occurring after the nominal moment capacity was reached and a bond failure was defined as a beam having more than 0.01 in average end-slip prior to reaching the calculated nominal moment capacity. The moment versus deflection and end-slip was plotted for each test. Each plot also included the nominal moment capacity calculated by the current AASHTO LRFD provisions and by strain compatibility. Figure 16 shows the aforementioned relationships for a typical flexural failure. Figure 17 shows the same relationships for a typical hybrid failure and Figure 18 shows the same relationships for a typical bond failure.

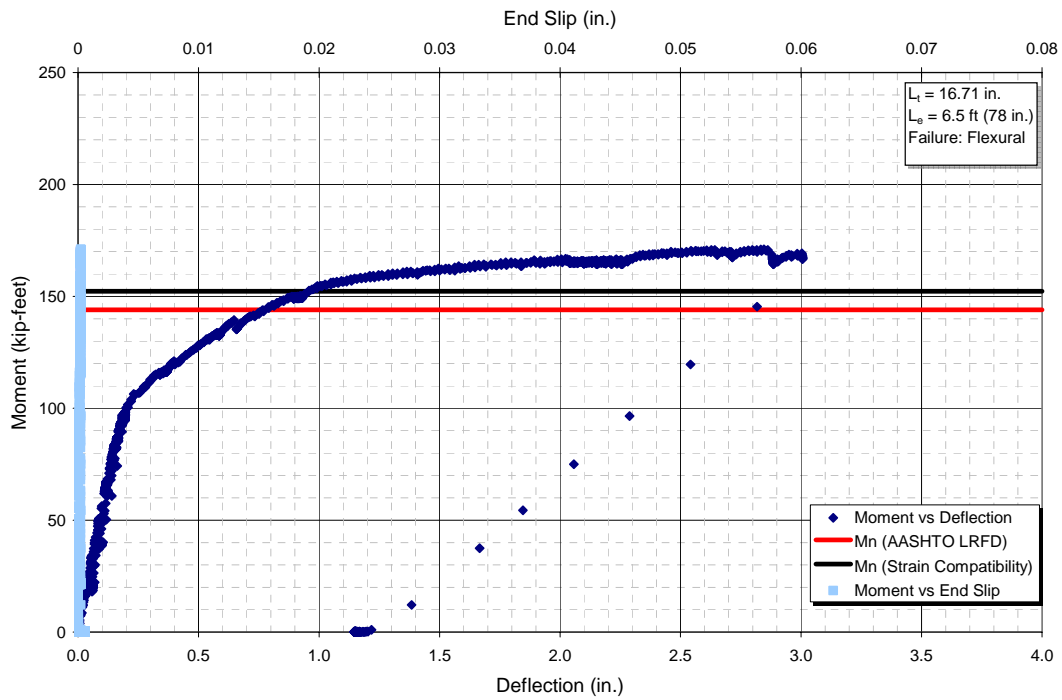

Figure 16. Moment versus deflection and end-slip (flexural failure).

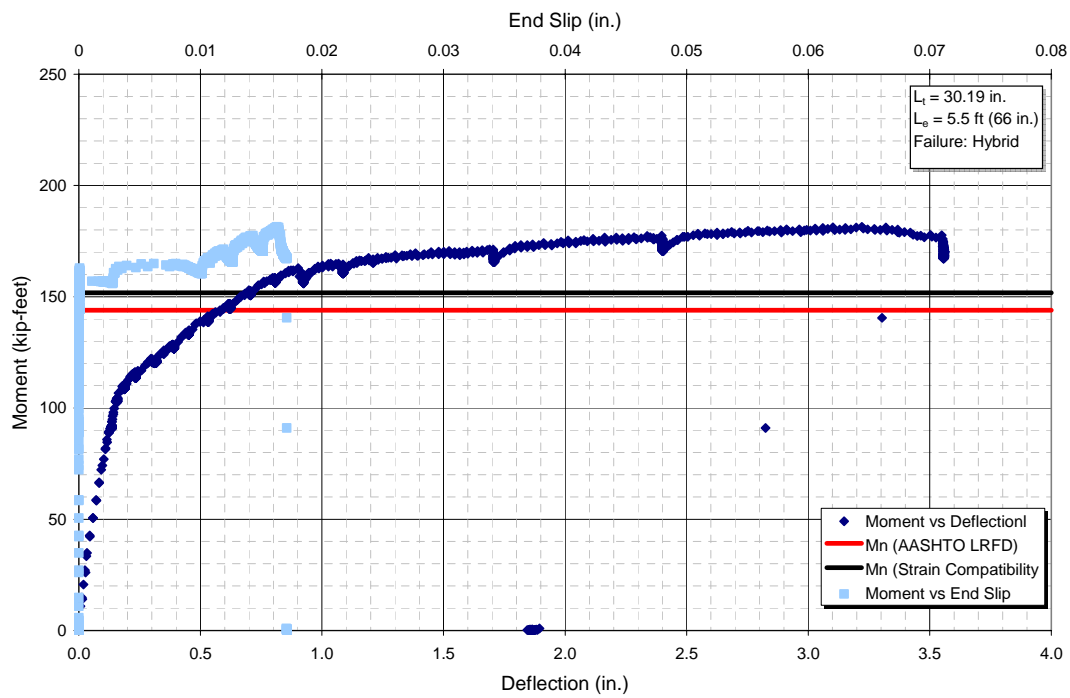

Figure 17. Moment versus deflection and end-slip (hybrid failure).

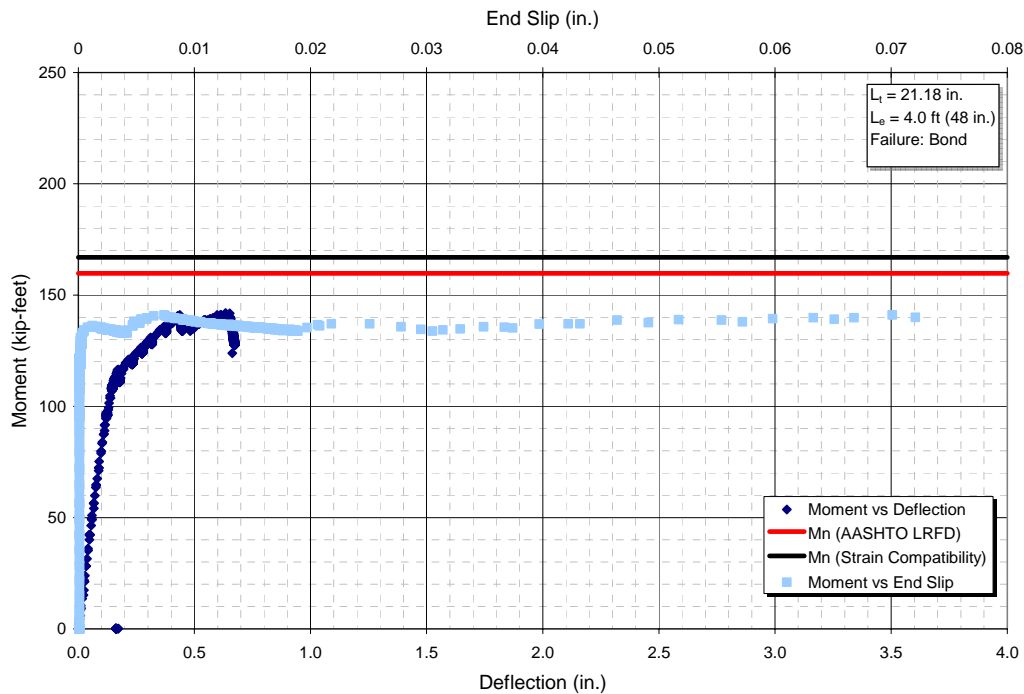

Figure 18. Moment versus deflection and end-slip (bond failure).

### Influence of Strand Strength

With the Grade 300 strand, there was a slight increase in the difference between the effective prestress and the stress in the strand at the nominal moment capacity, which was expected to increase the flexural bond length. Historically, development length equations separate transfer length and flexural bond length. Therefore, for each test specimen, the transfer length was subtracted from the tested embedment length ( $L_e - L_t$ ) to focus on the determination of the flexural bond length. When  $(L_e - L_t)$  was equal to or greater than the minimum required flexural bond length, a flexural failure occurred. On the contrary, when  $(L_e - L_t)$  was less than the minimum flexural bond length, a bond or hybrid failure would occur.

Of the test specimens containing  $\frac{1}{2}$  in diameter regular Grade 300 strands, the minimum flexural bond length resulting in a flexural failure was 45.9 in, while the minimum flexural bond length resulting in a flexural failure for the test specimens containing  $\frac{1}{2}$  in diameter regular Grade 270 strands was 47.6 in, showing relatively no difference in flexural bond length. For the test specimens containing  $\frac{1}{2}$  in diameter super Grade 300 strands, the minimum flexural bond length resulting in a flexural failure was 45.4 in, while the minimum flexural bond length resulting in a flexural failure for the test specimens containing  $\frac{1}{2}$  in diameter super Grade 270 strands was 46.1 in. Both test specimens had less than 0.001 in of slip. Comparisons for beams containing Grade 300 0.6 in diameter strands were not possible because the Grade 300, 0.6 in diameter strands was not being manufactured at the time. Overall, the Grade 300 strand performed very similarly to the Grade 270 strand.

A summary of the results for strand type are shown in Table 11. Although the Grade 300 strand may have a slightly higher flexural bond length, it was not possible to determine this with anymore precision as the interval of embedment lengths tested was 6 in. It should be noted that one test specimen containing Grade 300 ½ in diameter super strands with a ( $L_e - L_t$ ) value of 47.6 in did encounter a hybrid/shear failure.

**Table 11. Summary of Results for Strand Grade and Size**

Strand Strength	Minimum Determined Flexural Bond Length (in)		
	½ in diameter	½ in diameter super	0.6 in diameter
Grade 270	47.6	46.1	46.7
Grade 300	45.9	45.4	NA

### **Influence of Strand Diameter/Area**

Strand diameter has been shown by a number of researchers to affect the flexural bond length of prestressing strand. As with transfer length, most have found flexural bond length to increase with strand diameter, while some have shown flexural bond length to decrease when using 0.6 in diameter prestressing strand. As previously mentioned, three types of strand were used throughout the study, including ½ in regular, ½ in super, and 0.6 in diameter strands. All but two beams contained ½ in diameter strands, with the majority being ½ in diameter super strands; so, as with transfer length, no conclusions were made with respect to 0.6 in diameter strand and their influence on flexural bond length.

The minimum flexural bond length resulting in a flexural failure for the ½ in diameter strands, Grade 270 strand, was 46.8 in., while the minimum flexural bond length resulting in a flexural failure for the 0.6 in diameter Grade 270 strand was 46.7 in. As with the influence of strand strength, the strand diameter showed only a small increase in flexural bond length for a difference in strand diameter, but only four tests were performed with 0.6 in diameter strands. In addition to strand diameter, flexural bond lengths were also evaluated for each corresponding strand area. The minimum flexural bond length resulting in a flexural failure for the ½ in diameter regular Grade 270 strand was 45.9 in, while the minimum flexural bond length resulting in a flexural failure for the ½ in diameter super Grade 270 strand was 45.4 in. The minimum flexural bond length resulting in a flexural failure for the 0.6 in diameter strand was 46.7 in as previously stated. Again, no definitive trend was shown between strand type or strand grade in this study.

### **Influence of Effective Prestress**

Transfer length has been shown to increase with an increase in effective prestress. Since two levels of initial prestress and two strengths of strand were used resulting in various levels of effective prestress, ( $L_e - L_t$ ) for each test was plotted against each corresponding effective prestress, as shown in Figure 19. ( $L_e - L_t$ ) is defined as the embedment length of strand in a specimen beyond the measured transfer length. As was shown in Table 10, it can be observed in Figure 19 that the minimum flexural bond lengths required for flexural failures are in the range of 45 to 50 in regardless of strand size or grade. A significant amount of scatter existed in the plot among those test specimens failing in flexure indicating there to be no definitive trend.

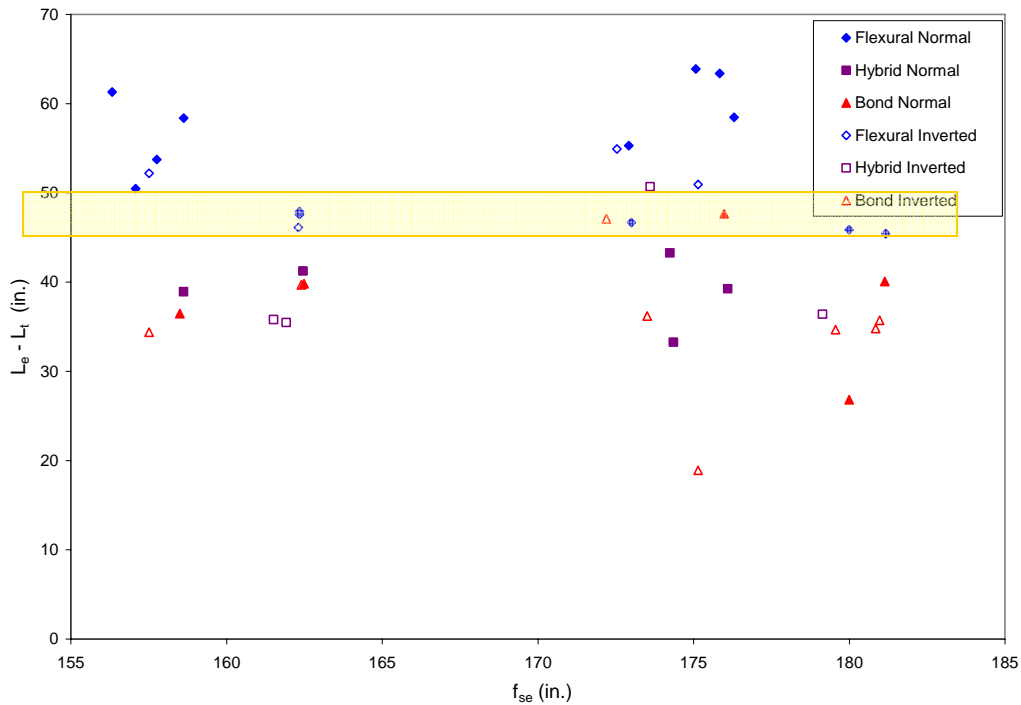

Figure 19. ( $L_e - L_t$ ) versus effective prestress.

### Influence of ( $f_{ps} - f_{se}$ )

The difference in the stress in the strand at the nominal moment capacity  $f_{ps}$  and the effective prestress  $f_{se}$  has been used in the calculation of the flexural bond length since the implementation of Equation (2-2) in ACI and has been incorporated into numerous proposed equations for the calculation of the flexural bond length. Figure 20 shows the relationship of ( $L_e - L_t$ ) and ( $f_{ps} - f_{se}$ ). As with strand diameter, although ( $f_{ps} - f_{se}$ ) has been shown to influence the flexural bond length, neither an increase nor decrease was observed for values of ( $L_e - L_t$ ) resulting in a flexural failure when compared to variations in ( $f_{ps} - f_{se}$ ). It appeared the flexural bond length for all strand types was in the range of 45 to 50 in.

### Influence of Concrete Strength

As with transfer length, the current code provisions do not account for the strength of the concrete in the calculation of flexural bond length. Although the strength of concrete is not accounted for, some researchers have shown flexural bond length to decrease with an increase in concrete strength, while others have shown very little correlation. Among the six sets of test specimens cast in this study for the development length tests, five different concrete strengths existed at the time of testing, ranging from 6300 to 8300 psi, which was representative of concrete strengths typically used in the bridge industry. Figure 21 plots ( $L_e - L_t$ ) values against the square root of each corresponding concrete strength. Again the flexural bond lengths appear to be between 45 and 50 in for all test specimens. There does however, appear to be a trend of increasing flexural bond length with an increase in concrete strength. This goes against other

studies and is attributed to the small amount of data points for higher concrete strengths in this study.

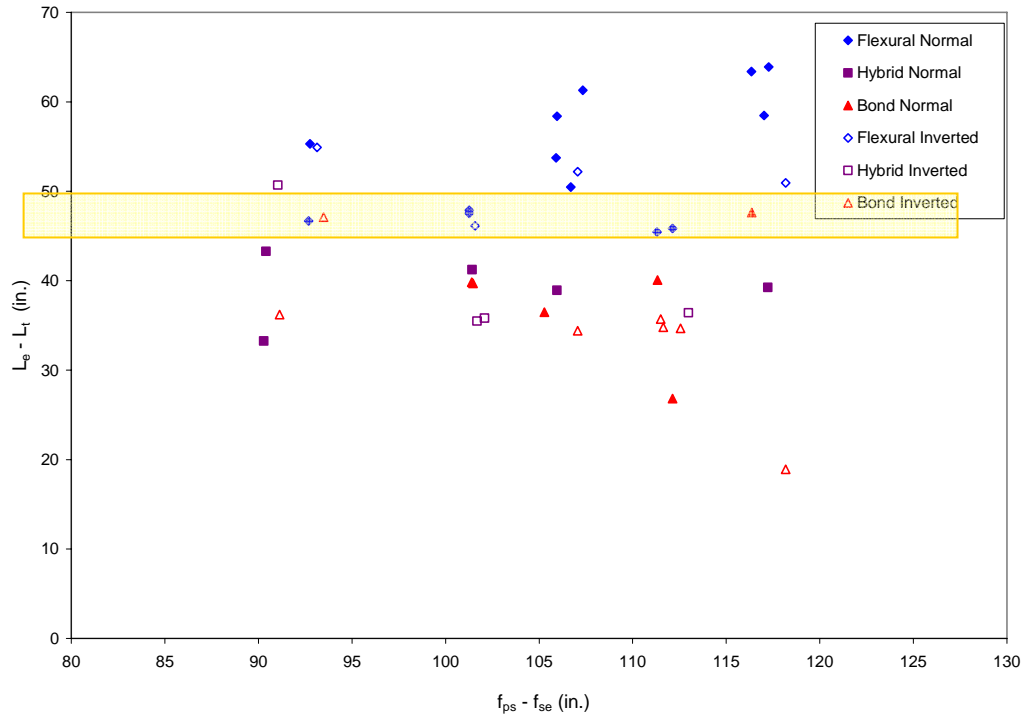

Figure 20. ( $L_e - L_t$ ) versus ( $f_{ps} - f_{se}$ )

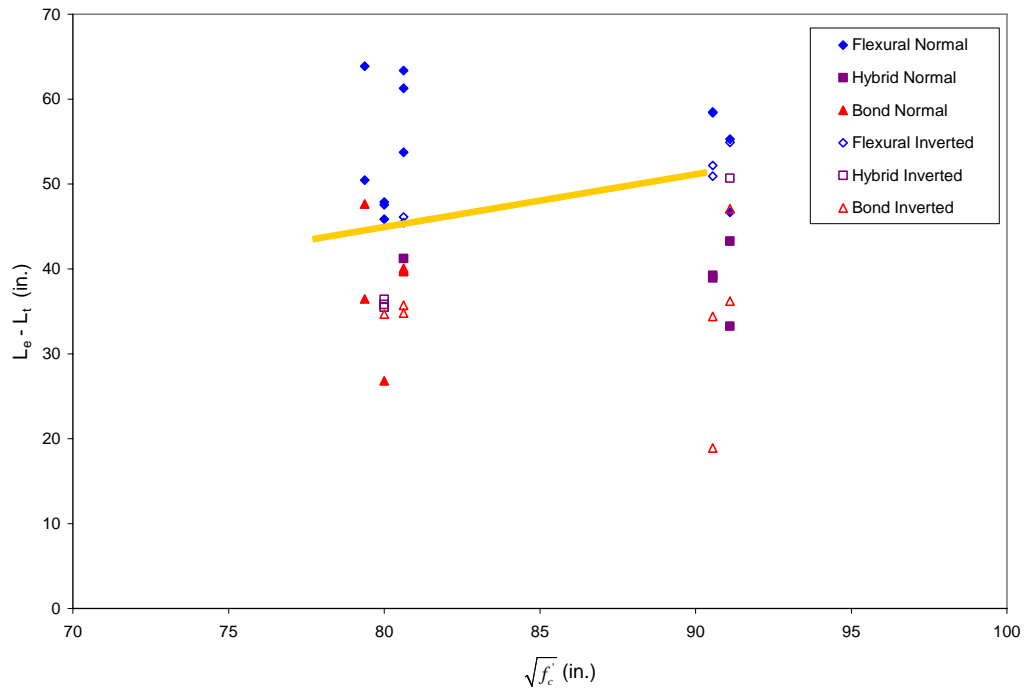

Figure 21. ( $L_e - L_t$ ) versus concrete strength.



## Influence of Casting Orientation

The top-strand effect has a significant influence on transfer length measurements and with respect to standard reinforcing bars, is very influential in the calculation of development lengths. Looking at the development lengths alone for prestressing strand, the top-strand effect appeared to have a significant influence. Figure 22 shows the relationship of embedment length and the amount of concrete cast below the strand. A number of the points with different failure types overlap as they had the same embedment length, but had different transfer lengths. The plot failed to show any solid relationship between any of the failure types and the amount of concrete cast below the strand because of the overlap. However, by subtracting out the measured transfer lengths, the transfer length and  $(L_e - L_t)$  were uncoupled, showing the top-strand effect to have very little effect on the flexural bond length. By subtracting out the transfer length, only looking at  $(L_e - L_t)$  values, the overlap was removed. Figure 23 shows the relationship of  $(L_e - L_t)$  values and the amount of concrete cast below the strand. Once again the minimum values of  $(L_e - L_t)$  resulting in a flexural failure appear to be between 45 and 50 in, showing no correlation to the amount of concrete cast beneath the strand.

As previously discussed, transfer lengths were found to be more dependent on the amount of concrete cast above the strand than the amount of concrete cast below the strand. Therefore, the embedment length and  $(L_e - L_t)$  values from each test were plotted against the amount of concrete cast above the strand. Figure 24 shows the relationship of the embedment length and the amount of concrete cast above the strand. A number of the points, again, overlapped from having the same embedment lengths, showing no correlation between any of the failure types and the amount of concrete cast above the strand. Again, the transfer lengths were subtracted out of each corresponding embedment length, resulting in  $(L_e - L_t)$  values. Figure 25 shows the relationship of the  $(L_e - L_t)$  values and the amount of concrete cast above the strand. The overlap was removed, but there was no correlation between  $(L_e - L_t)$  values resulting in flexural failures and the amount of concrete cast above the strand. Again, the range of minimum flexural bond lengths appears to be between 45 and 50 in.

By evaluation of the development length only, the top-strand effect appeared evident, however, by also evaluating the flexural bond lengths for each test, unlike transfer lengths, it was determined that the top-strand effect failed to have a significant influence on the flexural bond length. However, the development length equation consists of both the transfer and flexural bond lengths therefore the top-strand effect does influence the development length through the transfer length.

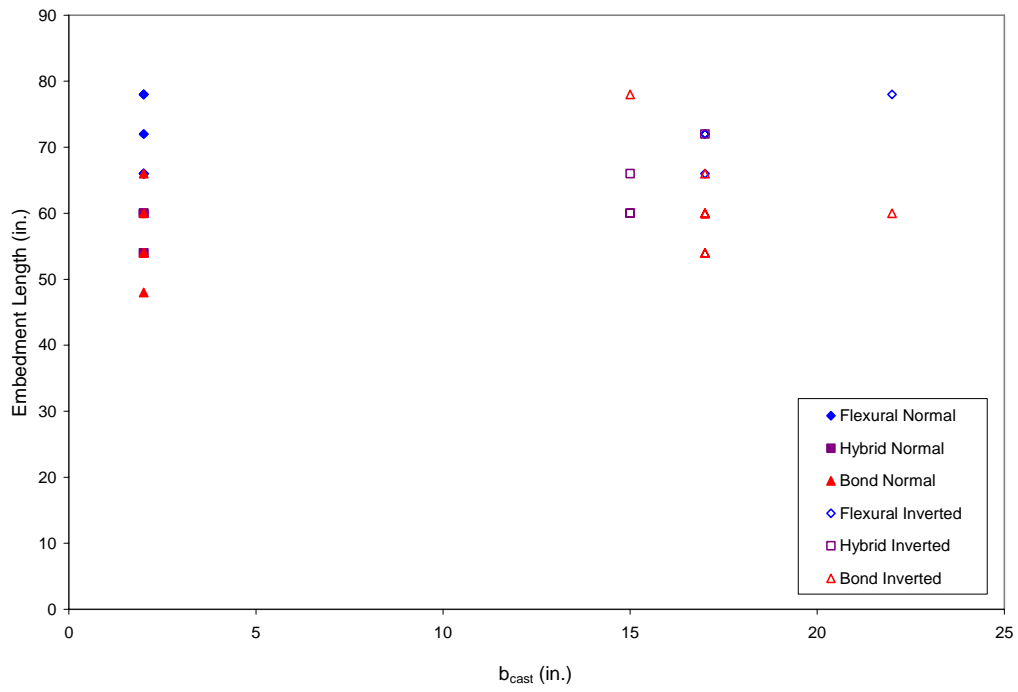

Figure 22. Embedment length versus  $b_{cast}$ .

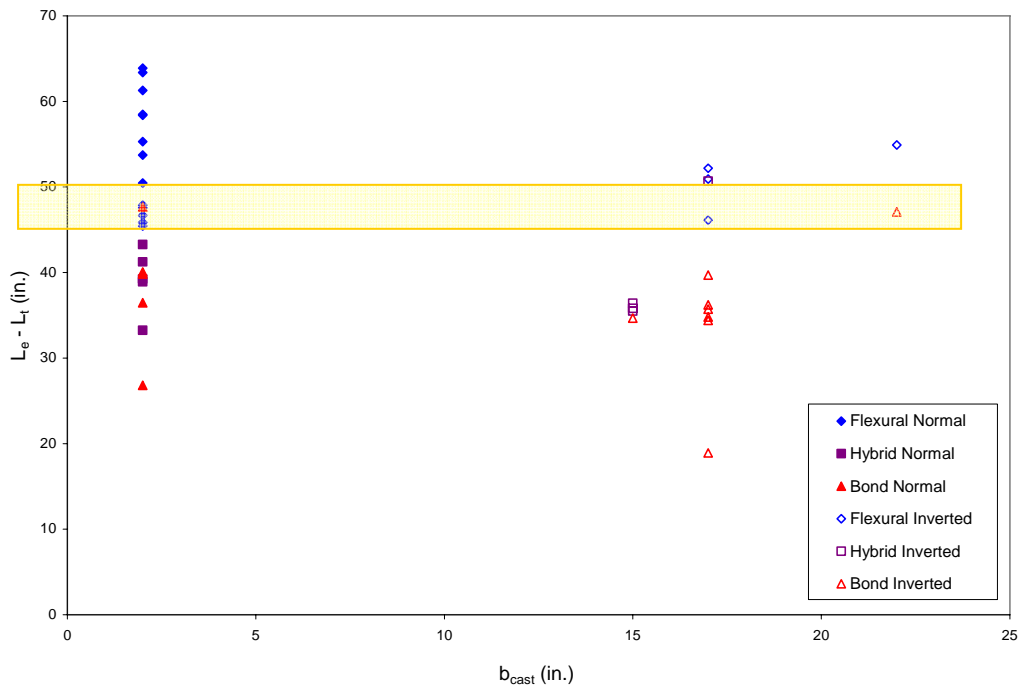

Figure 23.  $(L_e - L_t)$  versus  $b_{cast}$ .

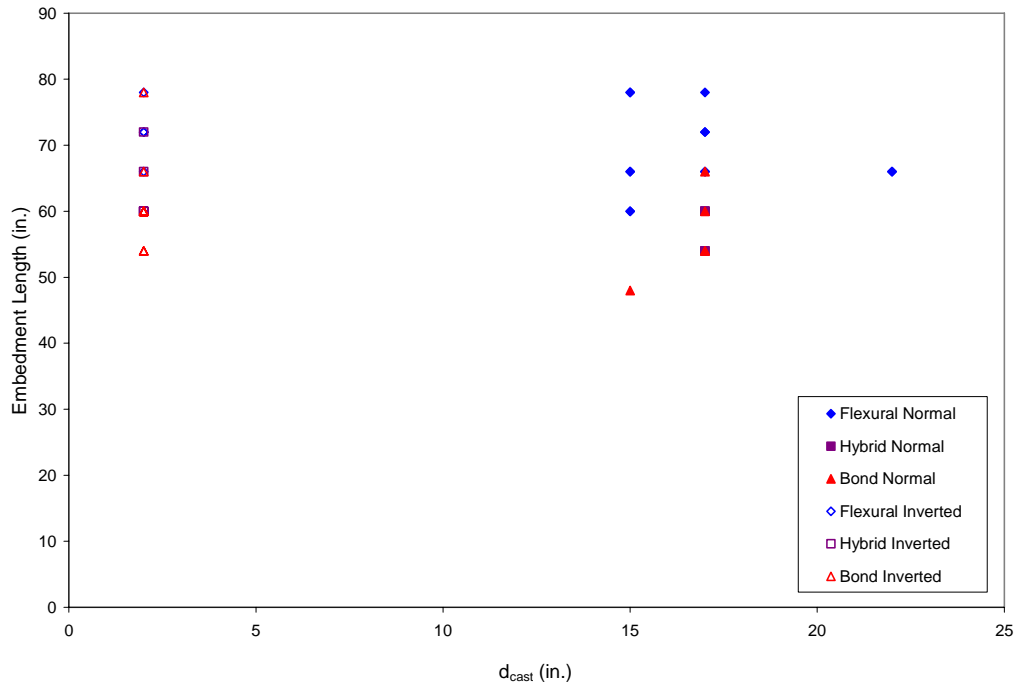

Figure 24. Embedment length versus  $d_{cast}$ .

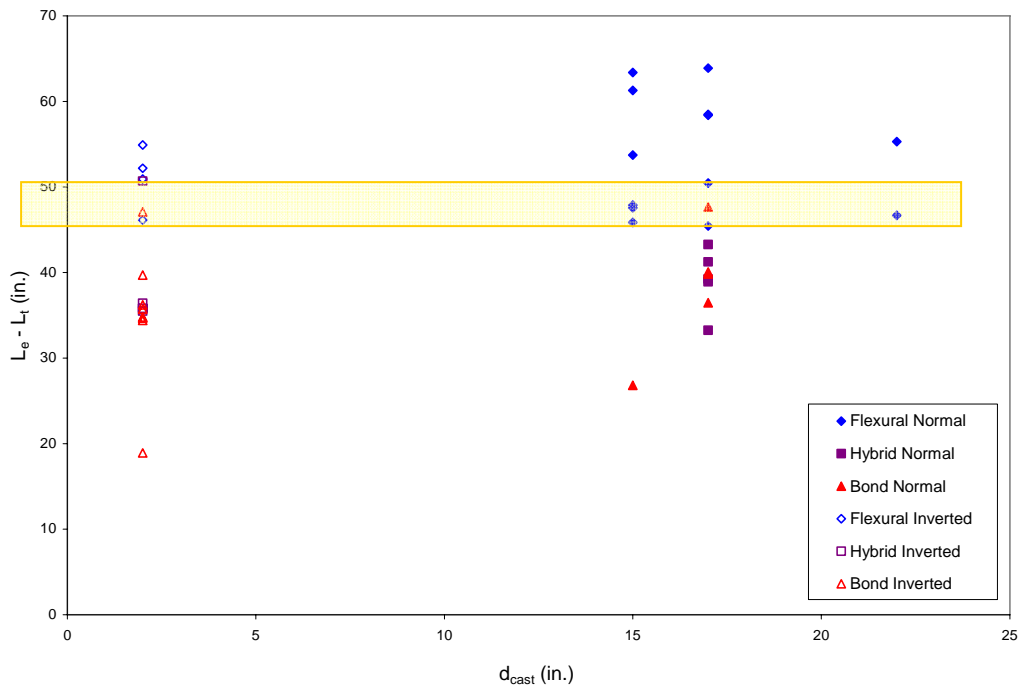

Figure 25.  $(L_e - L_t)$  versus  $d_{cast}$ .

## Flexural Strength

The single-point bending development length tests served two purposes, not only to evaluate development length, but also the flexural strength of each member for cases where the prestressing strand was fully developed. The primary objective in the evaluation of flexural strength was to determine the applicability of the current code provisions for use with the newer, higher strength Grade 300 strand. The flexural strength was also compared for beams containing Grade 300 strands and beams containing Grade 270 strands, as well as the flexural strength of beams cast with a normal orientation and beams cast with an inverted orientation. In addition to flexural strength evaluation, analytical curvature values were also determined and compared based on an assumed ultimate compressive strain in the concrete of 0.004.

Each of the experimentally determined values for flexural capacity was compared to code calculated values. Average results are shown in Table 12. Of the beams having less than 0.01 in of slip prior to reaching the nominal moment capacity based on current AASHTO provisions (flexural or hybrid failure), the average over strength of the T-beam test specimens was 15 percent. For beams containing Grade 300 strands, the average over strength was 16 percent while those containing Grade 270 strands had an over strength of 14 percent. The Grade 300 strand produced approximately the same average increase in nominal flexural capacity as beams containing Grade 270 strand as shown Table 12.

**Table 12. Summary of Flexural Tests Compared to AASHTO**

Strand Strength	Average Ratio of $M_{ACTUAL}/M_{AASHTO}$		
	½ in diameter	½ in diameter super	0.6 in diameter
Grade 270	1.14	1.15	1.13
Grade 300	1.16	1.15	NA

A direct comparison of measured flexural strengths for beams containing Grade 270 and Grade 300 strand was made. Table 13 shows that the flexural strengths of beams containing Grade 300 strand was 11% greater on average than similar beams containing Grade 270 strand. This matches the 11% additional ultimate strength available with Grade 300 strand.

In addition, curvatures of members containing Grade 300 and Grade 3270 strands are compared in Figure 14. Members containing Grade 300 strands showed about a 6 percent decrease in curvature, or ductility at the nominal moment capacity. Experimental comparisons were not made because identical members having different strand strengths were not always tested at the same embedment lengths and did not provide identical flexural failures for comparisons. Calculated ductilities were also the only values compared as ductility was not measured experimentally. Overall the T-beam test specimens performed very well in comparison to the current AASHTO provisions. The beams containing Grade 300 strands showed no significant differences with respect to the beams containing Grade 270 strands.

**Table 13. Summary of Calculated Flexural Strength for Casting Orientation**

Average Ratio of $M_{300}/M_{270}$		
½ in diameter	½ in diameter super	0.6 in diameter
1.11	1.11	NA

**Table 14. Summary of Calculated Curvature Comparison**

<b>Ratio of Calculated Curvatures</b>			
<b>Pour</b>	<b>Strand Size</b>	<b>Concrete Strength</b>	<b><math>\phi_{300}/\phi_{270}</math></b>
1	½ in regular	6500	0.941
2	½ in regular	6400	0.941
3	½ in super	8200	0.946
4	½ in super	6300	0.938
5	½ in super	6500	0.934
6	½ in super/0.6 in	8300	NA

## **CONCLUSIONS**

### **Grade 300 Strand**

- The current AASHTO Code provisions for the calculation of transfer length, development length, and flexural capacity are conservative for Grade 300 strand.
- The increased development lengths were found to be primarily dependent on the increase in transfer length both strand strengths. Minimum flexural bond lengths that resulted in flexural failures were found to be in the range of 45 to 50 in for both strand strengths.
- The members cast with ½ in diameter, Grade 300 strands had about 11 percent higher nominal moment capacities than did those cast with ½ in diameter, Grade 270 strands, but demonstrated lower ductility.

### **Effect of Vertical Casting Position**

- The top-strand effect is more dependent on the amount of concrete cast above the strand than the amount of concrete cast beneath the strand. The amount of concrete cast above the strand had the maximum impact on transfer length, resulting in an average increase of ½ in for every 1 in reduction in the amount of concrete cast above a strand.
- The current code provisions for the calculation of transfer lengths for top strand were found to be unconservative mainly due to the effect of the as-cast vertical location, which was found to be significantly more dependent upon the amount of concrete cast above the strand rather than the amount of concrete cast below the strand.
- The flexural bond length was found to not be influenced by the as-cast position of the strand. As with strand strength, the minimum flexural bond lengths resulting in flexural failures were in the range of 45 to 50 in.
- The current AASHTO Code provisions for the calculation of flexural strength are conservative for beams cast with an inverted orientation.

## RECOMMENDATIONS

1. *VDOT's Structure and Bridge Division* should use the current AASHTO equation for transfer length and development length for flexural members containing Grade 300 strand cast in non-top strand situations.
2. *VDOT's Structure and Bridge Division* should use the current ACI and AASHTO provisions for the calculation of nominal moment capacity for flexural members containing Grade 300 prestressing strands.

## BENEFITS AND IMPLEMENTATION PROSPECTS

As a result of this study a bridge structure located on Route 58 in Scott County, Virginia has been constructed with girders using 300 ksi strand. Grade 300 strand shows great promise to achieve high quality, long-lasting, prestressed concrete girders that will result in service lives exceeding 75 years. Potential benefits and cost savings will result from fewer strands required per girder, the associated reduced fabrication costs, and the increased flexural capacity in the individual girders. Further cost savings will result from longer spans and fewer girders required per span, thus saving fabrication and material costs and transportation and construction costs. Currently, the initial cost of Grade 300 strand is higher than Grade 270 strand but it is expected that this cost differential will be reduced as Grade 300 strand becomes more widely available.

## ACKNOWLEDGMENTS

The authors gratefully acknowledge the support provided by FHWA, the Innovative Bridge Research and Deployment Program, and the Virginia Department of Transportation.

## REFERENCES

- American Society for Testing and Materials. (2007). *AASHTO LRFD Bridge Design Specification Fourth Edition*. Washington, DC.
- American Concrete Institute. (2008). *Building Code Requirements for Structural Concrete and Commentary*. Farmington Hills, MI.
- American Society for Testing and Materials. (2005). *Standard Specification for Steel Strand, Uncoated Seven-wire for Prestressed Concrete*. A416-05/A416M-05, A, West Conshohocken, PA.

Buckner, C. D. (1995). A Review of Strand Development Length for Pretensioned Concrete Members. *PCI Journal*, 40(2), 84-105.

Loflin, B. J. (2008). *Bond and Material Properties of Grade 270 and Grade 300 Prestressing Strands*. Virginia Tech, Blacksburg.

Russell, B. W., and Burns, N. H. (1993). *Design Guidelines for Transfer, Development and Debonding of Large Diameter Seven Wire Strands in Pretensioned Concrete Girders*. University of Texas at Austin, Austin, TX.