

In vivo and modeling approaches to improve prediction of P availability in ruminants

Xin Feng

Dissertation submitted to the faculty of the Virginia Polytechnic Institute and State

University in partial fulfillment of the requirements for the degree of

Doctor of Philosophy

in

Animal Sciences, Dairy

Katharine F. Knowlton, Chair

Mark D. Hanigan

Chao Shang

Andrea M. Dietrich

May 1, 2015

Blacksburg, VA

Keywords: iron, phosphorus, dairy cow, Holstein steer, modeling

In vivo and modeling approaches to improve prediction of P availability in ruminants

Xin Feng

ABSTRACT

Improving prediction of P availability necessitates understanding of P digestion and absorption mechanism in ruminants. Greater knowledge of the interaction of P with other nutrients and the utilization of dietary P in the digestive tract will improve our ability to optimize P feeding and reduce P runoff in agricultural areas. In vivo experiments were performed and the data were used to reparameterize a model regarding P digestion and metabolism.

The interaction of P and iron was investigated in lactating dairy cows by infusing 0, 200, 500, or 1250 mg/d Fe (equivalent to 0, 2, 5, or 12.5 mg Fe/L in drinking water) in the form of ferrous lactate solution into the abomasum of lactating cows. Phosphorus absorption was not negatively influenced by abomasally infused ferrous lactate, and the highest infusion (1250 mg Fe/d) approximates a drinking water iron content far above that found in most samples from the field. In the second study the effects of dietary P intake on intestinal P absorption was evaluated in eight growing Holstein steers fitted with permanent duodenal and ileal cannulas. Diets varying in P content (0.15%, 0.27%, 0.36% and 0.45%, DM basis) were fed, and increasing P intake increased the quantity of P absorbed from the small intestine linearly without affecting the absorption efficiency (mean = 59.6%). Only a small portion of P absorption occurred in large intestine and this was not affected by dietary P concentration. An absence of change of salivary P secretion at low dietary P suggested rumen function was prioritized during short-term P deficiency.

Finally the data from these experiments along with four other studies were used to

parameterize the P digestion and metabolism model of Hill et al. (2008) to provide a better understanding of the digestion and metabolism of P fractions in cattle. The data used were adequate to parameterize the digestive elements of the model with good precision, and the model structure appears to be appropriate with no significant mean or slope bias. The resulting model could be used to derive P bio-availabilities of commonly used feedstuffs in cattle production. Although the model explained the data used with no apparent bias, this does not guarantee that the model parameters are valid for all conditions. Additional data are needed to evaluate this model in a wider range of scenarios.

ACKNOWLEDGEMENTS

I would like to express the deepest appreciation to my advisor, Dr. Knowlton, who has continually conveyed a spirit of adventure in regard to research and an excitement in regard to teaching. I thank her for making me a more confident person. Without her guidance and persistent help, completion of this degree would not have been possible for me.

I would like to thank my committee members, Dr. Hanigan, Dr. Shang, Dr. Dietrich who always gave me the help when I need. Thank Dr. Hanigan for his patience in helping me with the model development. Thank Dr. Shang for assisting me with the phytate quantification using high-performance ion chromatography (HPIC). Thank Dr. Dietrich for her suggestions on designing my first cow study. In addition, a thank you to other faculty members, staffs, and graduate/undergraduate students, especially my lab mates and office mates, thank you for making my four years here a great experience. I would like to convey my thanks to Shane, Curtis, Barry, and other farm crew for their generous help during my animal studies.

The last but not the least, I would like to thank my husband for supporting me these years. Without him, pursuing a degree in US is just something which never would cross my mind. I'm thankful to have him and Daniel, our son, in my life. I also thank my family members and friends who have been supporting me all these years.

ATTRIBUTION

Several colleagues aided in the writing and research behind some of my chapters as part of this dissertation. A brief description of their contributions is included here.

Chapter 3. Effect of abomasal ferrous lactate infusion on P absorption in lactating dairy cows.

Coauthor: K. F. Knowlton, A. D. Dietrich, and S. Duncan

Thanks to my advisor, Dr. K. F. Knowlton, for her guidance on the experiment implementation and assistance editing this paper. Thank Dr. A. D. Dietrich and Dr. S. Duncan for their suggestions on experiment design.

Chapter 4. Effect of different dietary P on intestinal P absorption on growing Holstein steers.

Coauthor: H. Schramm, E. Ronk, M. McCann, M. Hanigan, and K. Knowlton

Thanks to my advisor, Dr. K. F. Knowlton, for her guidance on the experiment implementing and assistance on editing this paper. Thanks to Dr. H. Schramm for performing surgery on the steers. Thanks to E. Ronk for his assistance on the experiment implement. Thanks to Drs. M. Hanigan and M. McCann for their help on ration formulation and suggestions on experiment design.

Chapter 5. Parameterization of a ruminant model of P digestion and metabolism

Coauthor: M. Hanigan, K. Knowlton

Thanks to Dr. K. F. Knowlton for her assistance on editing this paper. Thanks Dr. M. Hanigan for his assistance on the model development and editing the paper.

TABLE OF CONTENTS

ABSTRACT.....	ii
ACKNOWLEDGEMENTS.....	iv
ATTRIBUTION.....	v
TABLE OF CONTENTS.....	vi
LIST OF TABLES.....	ix
LIST OF FIGURES.....	x
Chapter 1 INTRODUCTION.....	1
Chapter 2 REVIEW OF LITERATURE.....	3
Environmental impact of P runoff.....	3
Phosphorus in ruminants.....	4
Physiological roles.....	4
Utilization and homeostasis.....	5
Effect of iron intake on P availability.....	7
Effect of P intake on P availability.....	9
Extant P models in ruminants.....	10
References.....	14
Chapter 3 EFFECT OF ABOMASAL FERROUS LACTATE INFUSION ON P ABSORPTION IN LACTATING DAIRY COWS.....	21
Abstract.....	22
Introduction.....	22
Materials and Methods.....	24
Animals, Experimental Design, and Sample Collection.....	24
Laboratory Analysis.....	25
Statistical Analysis.....	26
Results and Discussion.....	27
Dry Matter Intake and Digestibility.....	27
Phosphorus Intake and Absorption.....	28
Milk Production and Composition.....	29
Conclusions.....	30

References	32
Chapter 4 EFFECT OF DIETARY P ON INTESTINAL P ABSORPTION IN GROWING HOLSTEIN STEERS.....	40
Abstract	41
Introduction	42
Materials and Methods	43
Animals.....	43
Experimental Design and Sampling	44
Laboratory Analysis	45
Statistical Analysis	46
Results and Discussion.....	46
Diets, DMI, and Digestibility	46
Digestion and Absorption of P in Digestive Tract	47
Fecal P Excretion.....	49
Salivary P Secretion.....	50
Serum Pi and Urinary P	50
Conclusions	51
Acknowledgements	51
References	52
Chapter 5 PARAMETERIZATION OF A RUMINANT MODEL OF P DIGESTION AND METABOLISM	61
Abstract	62
Introduction	63
Materials and Methods	64
Overview	65
Model Changes	65
Experimental Data Description	70
Parameter Estimation and Model Evaluation	70
Results and Discussion.....	72
The Rumen	73

Small intestine and large intestine	74
Blood and Bone P	77
Sensitivity Analysis	78
Conclusions	80
Acknowledgements	80
References	82
Chapter 6 SUMMARY AND CONCLUSIONS.....	113

LIST OF TABLES

Table 3-1 List of ingredients of diet	36
Table 3-2 Effect of abomasal infusion of ferrous lactate on nutrient intake and digestibility.....	37
Table 3-3 Effect of abomasal infusion of ferrous lactate on intake and digestibility of total P, Pi and phytate	38
Table 3-4 Effect of abomasal infusion of ferrous lactate on milk yield and composition.....	39
Table 4-1 Ingredient and nutrient composition of diet	57
Table 4-2 Effect of dietary P content on DM intake and digestibility.....	58
Table 4-3 Effect of dietary P content on intake and absorption of total P and inorganic P (Pi	59
Table 5-1 Symbols used in the model.....	103
Table 5-2 Model inputs for Ray et al. (2012, 2013), Feng et al. (2011, personal communication), Feng et al. (2013), Feng et al. (2015) and Jarrett et al. (2014)	104
Table 5-3 Mean of observed data for Ray et al. (2012, 2013), Feng et al. (2011, personal communication), Feng et al. (2013), Feng et al. (2015) and Jarrett et al. (2014)	105
Table 5-4 Model parameter estimates and standard deviations derived from fitting to the data listed in Table 2.....	107
Table 5-5 Model prediction errors (RMSPE) associated with prediction of the data of six studies	108
Table 5-6 Global sensitivity coefficients of the fitted model. Coefficients represent the proportion of output variance associated with the parameter.	110
Table 5-7 P flow data for Feng et al. (2011, personal communication)	112

LIST OF FIGURES

Figure 5-1 Schematic representation of P absorption and metabolism in a lactating cow	97
Figure 5-2 Residual errors for predictions of total fecal P flow versus predicted flow.....	98
Figure 5-3 Residual errors for predictions of total fecal P flow versus the concentration of P in feed.....	99
Figure 5-4 P and bone P balance in response to varied milk yield.	100
Figure 5-5 P and bone P balance in response to varied dietary P (% of DM).	101
Figure 5-6 P balance in response to varied dietary P (% of DM) and varied phytate content (% of dietary P).....	102

Chapter 1 INTRODUCTION

Phosphorus (**P**) is a necessary nutrient for plants, animals and humans, and there are several reasons to rethink the management of P resources in the global food system (Cordell,2008). Phosphate rock is the main inorganic mineral source from which the fertilizers used in agricultural fields are derived. P contamination of surface water also mandates action on reserving and reducing unnecessary P use. Elevated P concentrations in water can directly increase the growth of aquatic vegetation, reducing the transmission of solar radiation and increasing production of toxins. A secondary effect of this contamination is a decrease in dissolved oxygen because bacteria utilize oxygen when decomposing the increasing dead vegetation. Eutrophication caused by excessive P released into aquatic systems impairs growth and survival of aquatic species (Smith et al., 1999). One final reason we need to reduce P use is that as a key non-renewable resource, there is no substitute for P. It cannot be manufactured or synthesized, and phosphate rock formation takes 10-15 million years from seabed to uplift and weathering. It is estimated that the current P reserves are likely to be depleted in 50-100 years. .

In cattle, the apparent digestibility of P is low causing most of dietary P to end up in the manure (Witt and Owens, 1983). Continuous land application of animal manure to meet crop N demand has resulted in a buildup of P, because the N to P ratio in manure typically does not match crop requirements (MacDonald et al., 2011). Excessive P often runs off into surface water aggravating eutrophication. Practices which reduce P excretion should be adopted yielding manure that more precisely meets crop needs thus reducing the risk of P loss.

Numerous studies reported that fecal P excretion is positively correlated with dietary P intake in dairy and beef cattle (Wu et al., 2000; Knowlton and Herbein, 2002; Geisert et al., 2010). Based on a national survey (Harrison et al., 2012), 99% of responding nutritionists feed

less P now than they did 5 years earlier. However, uncertainty regarding feed P availability is a barrier to further decreases. Current ruminant feeding standards assume homogenous P absorption from feeds within a few broad feed categories (NRC, 2001). However, previous studies have shown that grain processing (Duskova et al., 2001, Hill et al., 2002), grain type (Bravo et al., 2002, Guyton et al., 2003a), and exogenous enzymes (Knowlton et al., 2007) affect P digestion. Greater knowledge of the interaction of P with other nutrients (such as iron) and the utilization of dietary P in the digestive tract will improve our ability to optimize P feeding and reduce P runoff as per P use in Agricultural areas. Improved understanding of P absorption and recycling is essential to further refine P feeding recommendations.

Interactions between P and other nutrients must also be considered in strategies to better manage use of P in livestock diets. For instance, iron and P can form insoluble complexes which affect the absorption of P in the digestive tract causing more P excreted in the manure. Iron nutrition in dairy cattle hasn't been a major focus for dairy producers because iron ingestion from feedstuffs, soil, and water is usually sufficient to prevent deficiency. However, ferrous iron in water is highly soluble and more efficiently absorbed than dietary iron making it a potential risk factor of reduced P availability and even (in the extreme) iron toxicity.

The objective of this sequence of research projects were to 1) investigate how iron in the water affects P digestion in lactating cows, 2) the effects of dietary P on P digestion and metabolism in growing Holstein steers, and 3) parameterization of an existing ruminant model of P digestion and metabolism using data from six studies conducted by the same lab.

Chapter 2 REVIEW OF LITERATURE

Environmental impact of P runoff

Concentrated animal agriculture has been recognized as a significant source of phosphorus (**P**) contamination of surface water (Smith and Alexander, 2000). P losses from livestock farms are primarily from manure, and P excretion is primarily in the feces. Increased fecal P excretion with increasing dietary P has been reported in lactating dairy cows (Wu et al., 2000, Knowlton and Herbein, 2002) and steers (Geisert et al., 2010). Continued application of animal manure to land based on requirement of crops for nitrogen (N) has resulted in a buildup of P because the N to P ratio in manure often does not match crop requirements. Excess P built up in the soil is transported to streams, rivers, lakes etc. causing eutrophication (Sims, 1992).

It is imperative to decrease P loss from farms at the source, and its excretion in the manure. Thus practices that reduce P excretion are of interest to both environmentalists and animal scientists. Reducing the amount of P included in dairy cow rations is one of the most effective ways to cut P excretion (Kebreab et al., 2008). In some situations, reducing dietary P can also cut feed costs. In 2000, Wu et al. reported that P represented more than half of the cost of typical vitamin premixes provided for dairy cows. Since then, however, the increased popularity of high P byproduct feeds (e.g. distillers grains, corn gluten meal, corn gluten feed) has led to less frequent inclusion of P in mineral mixes.

Another reason that we need to reduce P excretion is that P is a non-renewable resource. Global P reserves have been declining significantly resulting in a subsequent increasing gap between demand and supply. It is expected that global peak P to occur around 2040 according to an analysis based on industry data (Cordell, 2008). The era of P as a cheap fertilizer has become a thing of the past. Due to the decline in quality and greater cost of extraction, refinement and

environmental management, the mining cost of phosphate rock is increasing while demand continues to increase (Cordell, 2008). The price of phosphate rock is almost five times the price in 2006.

For the both reasons, the environmental impact of P and its limited supply, attention to livestock P feeding practices is necessary. Surveys have revealed that dairy producers in the United States feed 0.45 to 0.50% dietary P which is in excess of recommendations by NRC (2001) and also the needs of lactating cows (Wu et al., 2001, Valk et al., 2002). P digestibility in dairy cows is low and fecal P excretion is highly correlated with P intake (Wu and Satter, 2000, Knowlton and Herbein, 2002, Valk et al., 2002). While practices have been adopted to reduce overfeeding of P to dairy cattle, such as decrease the supplementation of inorganic P, further progress will depend on an improved understanding of the availability of feed P. Decreasing P intake to reduce fecal P excretion is a way to reduce P runoff to the environment but this practice should be taken with caution as P deficiency can affect animal health and performance (Dias et al., 2007). Dietary P supplied needs to satisfy animal performance without impairing the environment. It is important to investigate the balance between the demand to improve animal performance and the need to reduce P excretion.

Phosphorus in ruminants

Physiological roles

As in humans, most of P in ruminants exists in bones and teeth as apatite, calcium phosphate. As an important component of adenosine triphosphate (ATP), cell walls and cell contents such as phospholipids, phosphoproteins, nucleic acids, P is present in every cell of the body. In blood and other body fluids, it is also involved in acid-base buffer system. Phosphorus concentration in blood plasma normally ranges from 4 to 8 mg/dL (6-8 mg/dL for growing cattle

and 4-6 mg/dL for adult animals; (NRC, 2001). Another reason P is a key mineral in ruminants is that it is required by ruminal microorganisms for cellulose digestion and synthesis of microbial protein (Breves and Schroder, 1991). Low P supply may directly harm the ruminal microorganism, thus affecting DM digestion. It was suggested that at least 60 mg of available P/L of medium was required to maximize cellulose disappearance (Chicco et al., 1965). Komisarczuk et al. (1987) also demonstrated that in a continuous rumen incubation system, cellulose digestion and volatile fatty acid production decreased when Pi concentration was lowered to 0.1 mM and microbial protein synthesis was reduced at Pi concentrations of less than 0.03 mM.

Utilization and homeostasis

Absorption of P mainly occurs in the small intestine while a small portion of P is also absorbed in the large intestine (Grace et al., 1974). It was also reported that small amounts are absorbed from the rumen, omasum and abomasum (Scott et al., 1984). In nonruminants, absorption of P occurs via two mechanisms: the passive transport system when normal to large amount of absorbable P is consumed, and a saturable vitamin D-dependent active transport when a low P diet is provided (NRC, 2001). The mechanism of P absorption in ruminants has rarely been reported. In sheep, the upper small intestine is the major absorptive site with both active transport and passive diffusion mechanisms (Care, 1994). With perfusion of the temporarily-isolated upper small intestine with NaH_2PO_4 (5 to 50 mmol/L), Scott et al. (1984) reported a curvilinear relationship between P absorption and P concentration; absorption efficiency fell from 0.74 at 5 mmol/L to 0.35 at 50 mmol/L. It was also reported that in sheep, as dietary P increased from 2.5 to 5.0 g/kg of DM, total P absorbed increased but efficiency of absorption was constant (Bravo et al., 2003a, 2003b).

Salivary P recycling is the main route getting rid of surplus P from the blood system while urinary P excretion serves as a compensatory mechanism when salivary gland efficiency is maximized (Scott and Buchan, 1985, 1987). Challa and Braithwaite (1989) indicated that compared to P intake, the absorption efficiency is more associated with urinary P excretion when the plasma P concentration exceeds a renal threshold (between 2.0 to 3.0 mM of P); below that, salivary gland play the important role clearing the excess P from blood. Endogenous fecal P mainly comes from salivary P (Vitti et al., 2000). Valk et al. (2002) indicated a direct positive relationship between plasma P and salivary P concentrations. The salivary glands of cattle can concentrate plasma P from 3- to 8-fold depending on salivary flow rate and plasma P concentration (Ternouth et al., 1985). Almost all salivary P is inorganic and it is absorbed across the intestine with equal or higher efficiency than dietary P (NRC, 2001). Salivary recycling of P makes ruminant different from monogastrics regarding maintaining of homeostasis of P. In monogastrics, the kidneys are most important in removing excess P from the blood, while, in ruminants, the salivary glands play this role (Care, 1994). In the model of Hill et al. (2008), in lactating cows fed 75 g of P per day, an estimated 53 g of P per day is recycled back from blood to the rumen which is later reabsorbed in the lower digestive tract or excreted in the feces.

Bone P absorption and desorption are important in regulating plasma P homeostasis, especially when P intake is low. In sheep fed low P diet the skeleton was severely desorbed to maintain plasma P concentrations (Benzie et al., 1959). Geisert et al. (2010) also indicated bone P storage was used to maintain P homeostasis in steers fed low P diet. Similarly, Puggaard et al. (2011) observed that P is not depositing in bone and bone P reserves was mobilized to maintain net P recycling in lactating dairy cows fed low P diet. Mobilized bone P also helps salivary P secretion to be maintained in P-deficient diets (Puggaard et al., 2011). This is likely important to

provide adequate P to rumen microbes. The magnitude of exchange of P between bone and blood is large. Given a 75 g intake of P, the Hill et al. (2008) model predicted approximately 480 g of P per day exchange between blood P and bone P pools.

In ruminants, the main route for disposing excess P is feces. Cattle normally excrete a small amount of urinary P daily with some variation between animals. It has been reported that total fecal P excreted contains more than 66% of endogenous P including the salivary P recycled (Bortolussi et al., 1996). Dias et al. (2006) reported although the goats fed P deficient diet had a negative P balance, endogenous P loss still occurred. Bone resorption, fecal and endogenous P excretion, and P absorption all play a role in maintaining P homeostasis in growing goats while urinary P excretion did not contribute homeostasis significantly.

Effect of iron intake on P availability

Iron in drinking water is among the most frequent and important anti-quality considerations for dairy cattle. Iron deficiency in adult cattle is rare because of abundant ferric iron (Fe^{3+}) in feedstuffs and soil but iron deficiency can occur when calves are fed only milk (or replacer) for a long time (Miller, 1981). However, excess total iron intake can be a problem. The predominant chemical form of iron in drinking water is the ferrous (Fe^{2+}) form which is water-soluble and more available compared with the highly insoluble ferric (Fe^{3+}) form present in feed sources (Ammerman et al., 1967). High iron concentration in water could pose a risk for cattle as adult cows can drink 90 to 150 L of water per day. The iron content of ground water varies with geographical and geological location. Deep well water sources tend to have higher content of iron than shallow wells. Iron concentrations in groundwater typically range from 0.5–10 mg/L with values up to 50 mg/L (Casey et al., 1983). Iron concentration in drinking water of greater than 0.3 ppm is considered a risk for human health (NRC, 2001), and Looper and Waldner

(2002) indicated that safe concentration of iron in water for cattle is less than 2 mg/L. Socha et al. (2003) reported that the average iron concentration of 2437 water samples analyzed out of 3651 samples collected throughout the United States was 0.79 mg/L; the maximum concentration observed was 123 mg/L.

The first concern is that high iron in drinking water may reduce the palatability of water thus affecting cattle health and production performance. Also, a dark slime formation in plumbing and waterers formed by iron-loving bacteria may affect water quality and the rate and volume of water flow through pipes. In addition, excess iron intake affects copper status (Boyne and Arthur, 1986, Chase et al., 2000) and availability of zinc (Standish et al., 1971). High iron in the diet may also affect rumen microorganism activity (Harrison et al., 1992). Finally, it has been observed that high levels of iron in water or feed may cause intestinal proliferation of *Clostridium botulinum* and subsequent botulism in chickens (Pecelunas et al., 1999).

Iron is highly reactive with P and interactions of dietary iron and P (each affecting the absorption of the other) have been reported in lambs (Lassiter, 1967) and rats (Harmon et al., 1968). Standish et al. (1971) reported that high diet P significantly decreased the iron level in the liver of the steer calves. The research on the iron and P interaction in adult cows is limited. These results suggest that iron-phosphate complexes may be formed in the intestinal tract, and these complexes are not easily absorbed by the animals. In addition, phytic acid and iron are also thought to form insoluble complexes which are not available for absorption under pH conditions of the small intestine (Minihane and Rimbach, 2002). Maenz et al. (1999) reported that at neutral pH, the rank order of mineral potency as phytate hydrolysis inhibitors was $Zn^{2+} > Fe^{2+} > Mn^{2+} >$

$\text{Fe}^{3+} > \text{Ca}^{2+} > \text{Mg}^{2+}$. The inhibitory effects of divalent cations tested was decreased by acidification of the media to pH 4.0. Genter (2011) evaluated the short term effects of abomasally infused iron (calculated to approximate 0, 4.5 and 9 ppm Fe concentration in drinking water) on the Fe status of mid-lactating cows and found that the infused iron did not have major impacts on short term Fe status of lactating cows. Unknown is the impact of iron intake on P availability in lactating cows; if there is an effect it will likely be of the soluble ferrous form in drinking water rather than the insoluble ferric form in feeds.

Effect of P intake on P availability

Flow of P entering the small intestine is highly correlated with dietary P intake. Absorption of Pi is related to its solubility (McDowell, 1992). Kebreab et al. (2005) showed that in four different experimental diets an average of 61% of the total duodenal P was water soluble. Mogodinyai and Holtenius (2012) reported a negative relationship between Pi absorption efficiency and the amount of Pi entering the small intestine. Field et al. (1983) and Grace et al. (1974) published similar results: as the amounts of Pi in the small intestine increases, the Pi net absorption tended to increase whereas the absorption efficiency decreased.

Little quantitative information is available regarding P absorption from the large intestine of ruminants, especially dairy cattle. Hoeller et al. (1988) observed net absorption of Pi from the sheep colon perfused with phosphate solutions *in vivo*, and net secretion of Pi when the perfusion fluid contained no Pi. In sheep, Grace et al. (1974) fed sheep at dry-matter intakes ranging from 450 to 1000 g per day and found net absorption of Mg, Ca, P and K from the large intestine at higher intakes. Sklan and Hurwitz (1985) reported only slight net absorption of Ca, P, Mg or K in the large intestine than in the small intestine whereas water, Na and Cl continued to be absorbed in large intestine. Also Poppi and Ternouth (1979) indicated that most of the net

absorption of Pi mainly occurs in the small intestine with a small portion of P absorbed in the caecum and colon. In situations of P scarcity, however, the pathway may be different. Scharrer (1985) reported the distal colon and even caecum can absorb P efficiently in sheep fed P-depleted diets. Similarly, degradation of phytate in the large intestine was reported by Park et al. (2002a) in sheep.

Extant P models in ruminants

Research to improve the understanding of P metabolism in ruminants has been going on for years. Numerous studies have been done to study the absorption of P using isotope dilution techniques (Braithwaite, 1983, Schneider et al., 1985), and the distribution of P and the kinetics of ^{32}P using radioisotopes (Grace, 1981, Schneider et al., 1987). Mathematical modeling is a useful tool to aid researchers to integrate information from multiple studies on P metabolism in ruminants. Most models deal with a specific nutrient and require detailed technical knowledge and special software. Several models have been developed to describe nutrient flows in ruminants.

Extant P models for dairy cows are mostly empirical (NRC, 2001) or have focused on interpreting tracer kinetic data on small ruminant P digestion and metabolism (sheep, goats; (Vitti et al., 2000, Dias et al., 2006, Dias et al., 2011). Vitti et al. (2000) developed a kinetic model of P metabolism in growing goats to investigate effects of increasing P intake on P utilization. Radioactive isotope ^{32}P was injected to trace P movement in the animal body. In this model, four pools were included (gut, blood, bone, soft tissue) to compute P exchanges in the system. It was concluded that the homeostatic control of P is via P absorption from digestive tract, bone P absorption and resorption, excretion of urinary P and endogenous and fecal P excretion. Another key finding was that the increase in P absorption efficiency was higher from

the deficient to moderate P diets than from moderate to high P diets. Exchange of P between blood pool and gut also increased when P intake was increased. The author suggested that the kinetic model could be extrapolated to both sheep and cattle.

Later Dias et al. (2006) extended the Vitti et al. (2000) model by including phytate P absorption and excretion, resulting in a more accurate representation of P metabolism since phytate P constitutes a large part of total dietary P. Phytate (*myo*-inositol hexakisphosphate) is the major P-containing compound in cereal grains. Phytate is not available by monogastrics because they have no endogenous phytase to degrade the compound. In ruminants, phytate is hydrolyzed by phytase produced by microbes in the rumen. Phytate utilization can be affected by feed treatment, Ca and Mg, rumen pH (Ellis and Tillman, 1961, Bravo et al., 2002). The revised model of Dias et al. (2006) describes P flows between bone, gut, plasma and soft tissue as a reflection of P metabolism and allows a comprehensive view of the distribution of P in addressing P demands, providing an improved P prediction compared to Vitti et al. (2000) model. Dias et al. (2007) studied P metabolism in growing sheep supplemented with different levels of dicalcium phosphate using the Dias et al. (2006) model. However, it's still unclear how the retained P in bone and soft tissue are exchanged with P from plasma, rumen and saliva. In 2011, Dias et al. again extended the Vitti-Dias model on P metabolism in ruminants by adding a rumen pool and a saliva pool to provide a more detailed and accurate description of P metabolism (Dias et al., 2011). In this work, the isotopic tracer technique was combined with appropriate mathematical modeling to obtain P estimates in saliva, rumen and also other pools. The model showed that excess consumed P is not efficiently used. The potential excess fecal P excretion is not only due to increased excretion of unabsorbed dietary P but also to increased endogenous P excretion. This extended model was the first to represent both saliva and the rumen.

The models described above have focused on interpreting tracer kinetic data of P digestion and metabolism in small ruminants. A dynamic model of P partition in cattle is required because they contribute significantly to P losses from farms. Kebreab et al. (2004) developed a dynamic, mechanistic, whole-animal dairy cow P model to simulate P flow by integrating three separate dynamic models of rumen function, on methane production and on N and P partition. Their model consists of ten state variables representing P pools in the rumen, small intestine, large intestine, blood and saliva. The model considered dietary P in two different forms: digestible P and indigestible P. The model simulates the fate of digestible P in the rumen, passage to the small intestine considered the main site of absorption (represented by Michaelis-Menten saturation kinetics), and finally excretion via feces after further digestion by microbes residing in the large intestine. Indigestible P is assumed to pass through the intestinal tract at the same rate as solid particles. The Kebreab et al. (2004) integrated model only applies to cows in mid-lactation, because it does not account for tissue catabolism, typical of cows in early lactation, or tissue anabolism in late lactation. The author indicated that it is possible to modify the selected model parameters to simulate other breeds and might also be improved by incorporating mechanisms to predict milk composition. To provide better understanding of P partitioning in the body and the time pattern and portioning of P to the environment, forms of fecal P (organic vs. inorganic, or water soluble vs. insoluble) should also be included.

The model of P digestion and metabolism in the lactating dairy cow by Hill et al. (2008) included for the first time different fractions of P (inorganic P, phytate P and nonphytate organic P) in different sites of the whole digestive tract (rumen, small intestine, large intestine) and P exchanges between the gut and blood pools. This model structure can accommodate differences in digestibility of different P forms. Parameters of P metabolism such as degradation of phytate P,

absorption of P in small intestine, and salivary P rate were derived. This model provides a clearer picture of P digestion and metabolism than earlier models. Data used (Knowlton et al., 2001, Schwab et al., 2006) were adequate to derive the parameters related to phytate degradation in the rumen and large intestine, absorption of inorganic P, intestinal digestion of non-phytate organic P, and the recycling of salivary P. The limitations of this model was that only data from lactating dairy cattle was used, and that dataset was limited. Data from growing cattle is also needed to broaden the model's utility, and additional data are needed to derive parameters associated with regulation of P absorption and bone P turnover.

References

- Ammerman, C. B., J. M. Wing, B. G. Dunavant, W. K. Robertson, J. P. Feaster, and L. R. Arrington. 1967. Utilization of inorganic iron by ruminants as influenced by form of iron and iron status of the animal. *J Anim Sci* 26:404-410.
- Bortolussi, G., J. H. Ternouth, and N. P. McMeniman. 1996. Dietary nitrogen and phosphorus depletion in cattle and their effects on liveweight gain, blood metabolite concentrations and phosphorus kinetics. *J. Agric. Sci.* 126:493-501.
- Boyne, R. and J. R. Arthur. 1986. Effects of molybdenum or iron induced copper deficiency on the viability and function of neutrophils from cattle. *Research in Veterinary Science* 41:417-419.
- Braithwaite, G. D. 1983. Calcium and phosphorus requirements of the ewe during pregnancy and lactation. 2. Phosphorus. *Br. J. Nutr.* 50:723-736.
- Braithwaite, G. D. 1984. Some Observations on Phosphorus Homeostasis and Requirements of Sheep. *Journal of Agricultural Science* 102:295-306.
- Bravo, D., C. Bogaert, F. Meschy, and D. Sauvant. 2003a. Plasma phosphorus content and dietary phosphorus availability in adult sheep. *Anim. Res.* 52:427-435.
- Bravo, D., F. Meschy, C. Bogaert, and D. Sauvant. 2002. Effects of fungal phytase addition, formaldehyde treatment and dietary concentrate on ruminal phosphorus availability. *Anim. Feed Sci. and Technol.* 99:73-95.
- Bravo, D., D. Sauvant, C. Bogaert, and F. Meschy. 2003b. Quantitative aspects of phosphorus excretion in ruminants. *Reprod. Nutr. Dev.* 43:285-300.
- Breves, G. and B. Schroder. 1991. Comparative aspects of gastrointestinal phosphorus metabolism. *Nutr. Res. Rev.* 4:125-140.
- Care, A. D. 1994. The absorption of phosphate from the digestive tract of ruminant animals. *Br. Vet. J.* 150:197-205.

Challa, J. and G. D. Braithwaite. 1989. Phosphorus and calcium metabolism in growing calves with special emphasis on phosphorus homeostasis. 4. Studies on milk-fed calves given different amounts of dietary phosphorus but a constant intake of calcium. *J. Agric. Sci.* 113:285-289.

Chase, C. R., D. K. Beede, H. H. Van Horn, J. K. Shearer, T. C. J. Wilcox, and G. A. Donovan. 2000. Responses of lactating dairy cows to copper source, supplementation rate, and dietary antagonist (iron). *J. Dairy Sci* 83:1845-1852.

Chicco, C. F., C. B. Ammerman, J. E. Moore, W. Von, L. R. Arrington, and R. L. Shirley. 1965. Utilization of inorganic ortho-, meta- and pyrophosphates by lambs and by cellulolytic rumen microorganisms in vitro. *J. Anim. Sci.* 24:355-363.

Cordell, D. 2008. 8 reasons why we need to rethink the management of phosphorus resources in the global food system. The Story of P Information Sheet 1, Global Phosphorus Research Initiative, Institute for Sustainable Futures, University of Technology, Sydney (UTS) Australia and Department of Water and Environmental Studies, Linköping University (LiU) SWEDEN.

Council, N. R. 1979. Iron.

Dias, R. S., E. Kebreab, D. M. Vitti, A. P. Roque, I. C. Bueno, and J. France. 2006. A revised model for studying phosphorus and calcium kinetics in growing sheep. *J. Anim. Sci.* 84:2787-2794.

Dias, R. S., E. Kebreab, D. M. S. S. Vitti, F. P. Portilho, H. Louvandini, and J. France. 2007. Phosphorus kinetics in lambs fed different levels of dicalcium phosphate. *Journal of Agricultural Science* 145:509-516.

Dias, R. S., S. Lopez, R. M. Patino, T. S. Silva, J. C. Silva Filho, D. M. Vitti, M. R. Pecanha, E. Kebreab, and J. France. 2011. An extended model of phosphorus metabolism in growing ruminants. *J. Anim. Sci.* 89:4151-4162.

Duskova, D., R. Dvorak, V. Rada, J. Doubek, and M. Marounek. 2001. Concentration of phytic acid in faeces of calves fed starter diets. *Acta Vet. Brno* 70:381-385.

Ellis, L. C. and A. D. Tillman. 1961. Utilization of phytin phosphorus in wheat bran by sheep *J. Anim. Sci.* 20:606-607.

Feng, X., H. Schramm, E. Ronk, M. McCann, M. Hanigan, and K. Knowlton. 2015. Effect of different dietary phosphorus on intestinal P absorption on growing Holstein steers. *J. Dairy Sci.* 98:1-7.

Field, A. C., J. Kamphues, and J. A. Woolliams. 1983. The effect of dietary intake of calcium and phosphorus on the absorption and excretion of phosphorus in chimaera-derived sheep. *The Journal of Agricultural Science* 101:597-602.

Geisert, B. G., G. E. Erickson, T. J. Klopfenstein, C. N. Macken, M. K. Luebbe, and J. C. MacDonald. 2010. Phosphorus requirement and excretion of finishing beef cattle fed different concentrations of phosphorus. *J. Anim. Sci.* 88:2393-2402.

Genther, O. N. 2011. Investigation of iron concentration, valence, and source effects on short-term iron(Fe) status and drinking water preference of lactation dairy cows. in *Animal Science*. Vol. M.S. Michigan State University.

Grace, N. D. 1981. Phosphorus kinetics in sheep. *Br. J. Nutr.* 45:367-374.

Grace, N. D., M. J. Ulyatt, and J. C. Macrae. 1974. Quantitative digestion of fresh herbage by sheep: III. The movement of Mg, Ca, P, K and Na in the digestive tract. *J. Agric. Sci.* 82:321-330.

Guyton, A. D., K. M. Burkholder, J. M. McKinney, and K. F. Knowlton. 2003. The effect of steam flaked or ground corn and supplemental phytic acid on P partitioning and ruminal phytase activity in lactating cows. *J Dairy Sci In Press*:

Harmon, B. G., D. E. Becker, A. H. Jensen, and H. W. Norton. 1968. Effect of Na₂EDTA in diets of different iron on utilization of calcium, phosphorus and iron by rats. *J Anim Sci* 27:

Harrison, G. A., K. A. Dawson, and R. W. Hemken. 1992. Effects of high iron and sulfate ion concentrations on dry matter digestion and volatile fatty acid production by ruminal microorganisms. *J Anim Sci* 70:1188-1194.

Harrison, J., K. F. Knowlton, B. James, M. D. Hanigan, C. Stallings, and E. Whitefield. 2012. Case study : National survey of barriers related to precision phosphorus feeding. *Prof. Anim. Sci.* 28:564-568.

Hill, B. E., S. L. Hankins, J. F. Kearney, J. D. Arseneau, D. T. Kelly, S. S. Donkin, B. T. Richert, and A. L. Sutton. 2002. Effects of feeding low phytic acid corn and phytase on phosphorus balance in lactating dairy cows. *J. Dairy Sci* 85 (Suppl. 1):44.

Hill, S. R., K. F. Knowlton, E. Kebreab, J. France, and M. D. Hanigan. 2008. A model of phosphorus digestion and metabolism in the lactating dairy cow. *J. Dairy Sci.* 91:2021-2032.

Hoeller, H., A. Figge, J. Richter, and G. Breves. 1988. Calcium and inorganic phosphate net absorption from the sheep colon and rectum perfused in vivo. *J. Anim. Phys. Anim. Nutr.* 59:9-15.

Kebreab, E., J. A. N. Mills, L. A. Crompton, A. Bannink, J. Dijkstra, W. J. J. Gerrits, and J. France. 2004. An integrated mathematical model to evaluate nutrient partition in dairy cattle between the animal and its environment. *Animal Feed Science and Technology* 112:131-154.

Kebreab, E., N. E. Odongo, B. W. McBride, M. D. Hanigan, and J. France. 2008. Phosphorus utilization and environmental and economic implications of reducing phosphorus pollution from Ontario dairy cows. *J Dairy Sci* 91:241-246.

Kebreab, E., M. A. Shah, D. E. Beever, D. J. Humphries, J. D. Sutton, J. France, and I. Mueller-Harvey. 2005. Effects of contrasting forage diets on phosphorus utilisation in lactating dairy cows. *Livest. Prod. Sci.* 93:125-135.

Knowlton, K. F. and J. H. Herbein. 2002. Phosphorus partitioning during early lactation in dairy cows fed diets varying in phosphorus content. *J. Dairy Sci.* 85:1227-1236.

Knowlton, K. F., J. H. Herbein, M. A. Meister-Weisbarth, and W. A. Wark. 2001. Nitrogen and phosphorus partitioning in lactating Holstein cows fed different sources of dietary protein and phosphorus. *J Dairy Sci* 84:1210-1217.

Knowlton, K. F., M. S. Taylor, S. R. Hill, C. Cobb, and K. F. Wilson. 2007. Manure nutrient excretion by lactating cows fed exogenous phytase and cellulase. *J. Dairy Sci* 90:4356-4360.

Komisarczuk, S., R. J. Merry, and A. B. McAllan. 1987. Effect of different levels of phosphorus on rumen microbial fermentation and synthesis determined using a continuous culture technique. *Br. J. Nutr.* 57:279-290.

Lassiter, J. W. 1967. Effect of phosphorus on the net absorption of minerals in coastal hay fed to sheep. *Georgia Academy of science* 25:65.

Looper, M. L. and D. N. Waldner. 2002. *Water for Dairy Cattle*. New Mexico State University, Cooperative Extension Service.

Maenz, D. D., C. M. Engele-Schaan, R. W. Newkirk, and H. L. Classen. 1999. The effect of minerals and mineral chelators on the formation of phytase-resistant and phytase-susceptible forms of phytic acid in solution and in a slurry of canola meal. *Animal Feed Science and Technology* 81:177-192.

McDowell, L. R. 1992. *Minerals in animal and human nutrition*. Animal feeding and nutrition. Academic Press, San Diego.

Miller, W. J. 1981. Mineral and vitamin nutrition of dairy cattle. *J Dairy Sci* 64:1196-1206.

Minihane, A. M. and G. Rimbach. 2002. Iron absorption and the iron binding and anti-oxidant properties of phytic acid. *International Journal of Food Science and Technology* 37:741-748.

Mogodinyai, K. K. and K. Holtenius. 2012. Phosphorus net absorption in dairy cows subjected to abomasal infusion of inorganic phosphorus – a pilot study. *J Anim Physiol Anim Nutr (Berl)* 1-4.

NRC. 2001. *Nutrient Requirements of Dairy Cattle: Seventh Revised Edition*. The National Academies Press.

Nutrient requirements of dairy cattle. 2001. Page 139. 7th rev. ed. National Academy Press, Washington, D.C.

Park, W. Y., T. Matsui, and H. Yano. 2002. Post-ruminal phytate degradation in sheep. *Animal Feed Science and Technology* 101:55-60.

Pecelunas, K. S., D. P. Wages, and J. D. Helm. 1999. Botulism in chickens associated with elevated iron levels. *Avian Diseases* 43:783-787.

Poppi, D. P. and J. H. Ternouth. 1979. Secretion and Absorption of Phosphorus in the Gastro-Intestinal Tract of Sheep Fed on 4 Diets. *Australian Journal of Agricultural Research* 30:503-512.

Scharrer, E. 1985. Phosphate absorption at different intestinal sites in the developing lamb. *Quarterly Journal of Experimental Physiology* 70:615-621.

Schneider, K. M., R. C. Boston, and D. D. Leaver. 1987. Quantitation of phosphorus excretion in sheep by compartmental analysis. 252 720–731.

Schneider, K. M., J. H. Ternouth, C. C. Sevilla, and R. C. Boston. 1985. A Short-Term Study of Calcium and Phosphorus Absorption in Sheep Fed on Diets High and Low in Calcium and Phosphorus. *Aust. J. Agric. Res.* 36:91-105.

Schwab, E. C., C. G. Schwab, R. D. Shaver, C. L. Girard, D. E. Putnam, and N. L. Whitehouse. 2006. Dietary forage and nonfiber carbohydrate contents influence B-vitamin intake, duodenal flow, and apparent ruminal synthesis in lactating dairy cows. *J Dairy Sci* 89:174-187.

Scott, D. and W. Buchan. 1985. The effects of feeding either roughage or concentrate diets on salivary phosphorus secretion, net intestinal phosphorus absorption and urinary phosphorus excretion in the sheep. *Q J Exp Physiol* 70:365-375.

Scott, D. and W. Buchan. 1987. The Effects of Feeding Either Hay or Grass Diets on Salivary Phosphorus Secretion, Net Intestinal Phosphorus Absorption and on the Partition of Phosphorus Excretion between Urine and Feces in the Sheep. *Quarterly Journal of Experimental Physiology and Cognate Medical Sciences* 72:331-338.

Scott, D., A. F. McLean, and W. Buchan. 1984. The effect of variation in phosphorus intake on net intestinal phosphorus absorption, salivary phosphorus secretion and pathway of excretion in sheep fed roughage diets. *Q. J. Exp. Physiol.* 69:439-452.

Sims, J. T. 1992. Environmental management of phosphorus in agricultural and municipal wastes. Pages 59-64 in *Future directions for agricultural phosphorus research*. Natl. Fert. Environ, Res. Center. TVA, Muscle Shoals, AL.

- Sklan, D. and S. Hurwitz. 1985. Movement and absorption of major minerals and water in ovine gastrointestinal tract. *J. Dairy Sci.* 68:1659-1666.
- Smith, R. A. and R. B. Alexander. 2000. Sources of nutrients in the nation's watersheds. in *Managing nutrients and pathogens from animal agriculture*. Natural resource, Agriculture, and Engineering Service (NRAES), Camp Hill, PA.
- Socha, M. T., S.M.Ensley, D.J.Tomlinson, and A.B.Jhonson. 2003. Variability of Water Composition and Potential Impact On Animal Performance. Pages 85-96 in *Proc. Intermountain Nutrition Conference*.
- Standish, J. F., C. B. Ammerman, A. Z. Palmer, and C. F. Simpson. 1971. Influence of dietary iron and phosphorus on performance, tissue mineral composition and mineral absorption in steers. *J Anim Sci* 33:171-178.
- Ternouth, J. H., H. M. S. Davies, J. T. B. Milton, M. W. Simpsonmorgan, and N. E. Sands. 1985. Phosphorus-Metabolism in Ruminants.1. Techniques for Phosphorus Depletion. *Aust. J. Agric. Res.* 36:637-645.
- Valk, H., L. B. J. Šebek, and A. C. Beynen. 2002. Influence of Phosphorus Intake on Excretion and Blood Plasma and Saliva Concentrations of Phosphorus in Dairy Cows. *J. Dairy Sci.* 85:2642-2649.
- Vitti, D. M., E. Kebreab, J. B. Lopes, A. L. Abdalla, F. F. De Carvalho, K. T. De Resende, L. A. Crompton, and J. France. 2000. A kinetic model of phosphorus metabolism in growing goats. *J. Anim. Sci.* 78:2706-2712.
- Wu, Z. and L. D. Satter. 2000. Milk production and reproductive performance of dairy cows fed two concentrations of phosphorus for two years. *J Dairy Sci* 83:1052-1063.
- Wu, Z., L. D. Satter, A. J. Blohowiak, R. H. Stauffacher, and J. H. Wilson. 2001. Milk production, estimated phosphorus excretion, and bone characteristics of dairy cows fed different amounts of phosphorus for two or three years. *J. Dairy Sci.* 84:1738-1748.
- Wu, Z., L. D. Satter, and R. Sojo. 2000. Milk production, reproductive performance, and fecal excretion of phosphorus by dairy cows fed three amounts of phosphorus. *J. Dairy Sci.* 83:1028-1041.

**Chapter 3 EFFECT OF ABOMASAL FERROUS LACTATE INFUSION ON P
ABSORPTION IN LACTATING DAIRY COWS**

Feng, X., K. F. Knowlton, A. D. Dietrich, and S. Duncan. 2013. Effect of abomasal ferrous lactate infusion on phosphorus absorption in lactating dairy cows. *J. Dairy Sci.* 96:4586-4591.

*Used by permission of the Journal of Dairy Science

Abstract

The objective of this study was to evaluate the effect of ferrous lactate infusion on post-ruminal P (**P**) absorption in lactating dairy cows. Four ruminally-cannulated lactating cows were used in a 4×4 Latin square with 14 d in each period. Cows were fed a basal diet containing 0.39% P, providing 100% of the calculated P requirement. On d 8 to d 14 of each period, each cow was infused with 0, 200, 500, or 1250 mg/d Fe in the form of ferrous lactate solution (ferrous lactate in 1 L double distilled water) into abomasum. Infusate was formulated to approximate 0, 2, 5, or 12.5 mg Fe/L in drinking water. Total fecal collection was conducted in the last 4 days of each period to measure nutrient digestion and excretion. Dry matter intake, milk yield, and milk composition were not affected by treatment. However, digestibility of DM, NDF, and nitrogen decreased linearly with increasing ferrous lactate infusion. Infusion of ferrous lactate did not affect intake and digestibility of total P, inorganic P (**Pi**), and phytate. In lactating cows P absorption was not negatively influenced by abomasally infused ferrous lactate up to 1250mg Fe/d.

Key words: dairy cow, ferrous lactate, phosphorus absorption

Introduction

Iron is an essential micro-mineral in cattle nutrition but little research has been done evaluating its requirement in lactating cows in recent decades. It is common for iron in ruminant diets to exceed animal requirements by 5-fold or more (Spears, 2009). With the high content of Fe (200 mg/kg) in feedstuffs and soil, iron deficiency is rare (Under wood and Suttle, 1999) and generally only observed in calves fed solely milk or milk replacer. The primary regulation of the body iron status is at the point of absorption (Frazer and Anderson, 2005). Excessive iron

absorbed into the enterocytes is incorporated into the iron storage protein ferritin in the enterocytes which can be excreted out of the body as the cell is sloughed and excreted into feces.

Iron toxicity is also uncommon in adult cows except in extreme situations (Miller, 1981). Iron in forages is primarily in the form of ferric oxide, relatively insoluble and poorly absorbed; NRC (2001) assigns an absorption coefficient of 0.10 to dietary Fe, with a maximum recommendation of 1000 mg/kg DM. Cows grazing pasture irrigated with high Fe water (17 mg/L) had reduced milk yield and their feces were dark, frothy, and malodorous (Coup and Campbell, 1964). In addition, cows grazing pasture irrigated with high Fe water had greater BW loss than cows grazing pastures not irrigated by high Fe water.

Interactions with Fe may interfere with digestion and absorption of other nutrients. Steers fed high Fe diets (1000 mg Fe/ kg DM as ferrous sulfate) had lower ADG and darker rumen color, an indicator of Fe toxicity, than those fed low Fe (100 mg Fe/kg DM) diets (Standish et al., 1971). Concentrations of Cu and P in plasma and liver were also reduced in the high Fe group, but high P intake seemed to alleviate the negative effect of high Fe intake with rumen color less dark in the high P high Fe treatment. The observed interaction of dietary P and Fe was likely due to formation of insoluble complexes of P and Fe in the digestive tract (e.g., FePO_4), decreasing the availability of both elements.

Iron in groundwater is primarily in the ferrous and dissolved form so it is more readily absorbed and potentially more toxic than the ferric oxide form common in feedstuffs (Standish et al., 1969, Thomas, 1970). Adult cows drink 90 and 150 L of water per day, making it a potentially significant source of available iron. Anaerobic groundwater may contain ferrous iron in mg per liter concentrations. Water iron higher than 0.3 mg per liter is considered not acceptable for human consumption. Socha et al. (2003) recommended that Fe in drinking water

for dairy cows should be less than 0.4 mg per liter and reported that 41% of the samples exceeding upper level for livestock.

Excess iron available in the intestinal tract can interfere with absorption of other minerals and may cause oxidative stress, bacterial infection, diarrhea, and reduced weight gain (Coup and Campbell, 1964, Standish et al., 1971, Bullen et al., 1978, McGuire et al., 1985). Genther (2011) reported lower water intake in lactating cows abomasally infused with ferrous lactate equivalent to 8 mg Fe/L of drinking water. Iron is the third most frequent and important anti-quality consideration for dairy cattle and iron toxicity is sometimes exacerbated in transition cows and fresh cows (Beede, 2005).

We hypothesized that because Fe in ferrous form can be more easily absorbed than Fe in ferric form, high doses of ferrous lactate would affect cow health and production performance. With its ability to complex P, high Fe in water might also compromise absorption of P. The objective of this experiment was to determine the effects of abomasal infusion of ferrous lactate on production, nutrient digestion, and P absorption in lactating dairy cows.

Materials and Methods

Animals, Experimental Design, and Sample Collection

All protocols and procedures were approved by Virginia Tech Institutional Animal Care and Use Committee. Four ruminally-cannulated early lactation cows (2 Holstein and 2 Holstein × Jersey) averaging 56 DIM (SD = 27) were fed a basal diet containing 0.39% P, providing 100% of the calculated P requirement (NRC, 2001). Treatments (abomasal infusion of 0, 200, 500, or 1250mg Fe/d as ferrous lactate solution) were imposed in a 4 × 4 Latin square design with 14 day periods. Treatments were formulated to approximate 0, 2, 5, or 12.5 mg Fe/L concentrations in drinking water.

Cows were individually fed in Calan doors (American Calan, Northwood, NH) once daily at 1200 h on d 1 to 7 and had constant access to feed except during milking. From d 8 to 14 of each period, cows were fed twice daily in individual tie stalls and were milked twice daily at 0600 and 1800 h, with continuous access to diet and water. Feed was offered at 5-10% in excess of previous day's intake (wet basis). Starting from 1800 h on d 8 and continuing to 1800 h on d 14 of each period, each cow was infused daily with 1 L 0, 200, 500, or 1250mg Fe/L of ferrous lactate solution into the abomasum. The solution was made of ferrous lactate in double distilled water and the Fe concentration of the solution was monitored daily.

Samples of TMR and feed refusals were collected daily and stored at -20°C. Total fecal collection was conducted in the last 4 d of each period. At 1800 h on each day feces from each cow was weighed and thoroughly blended. A representative sample was collected and stored at -20°C. Milk yield was recorded and milk samples were collected at 8 consecutive milkings from d 11 to 14. Blood samples were obtained on d 13 and 14 of each period from coccygeal vessel and saved in Vacuette tubes (Greiner Bio-One, Monroe, NC). Serum was separated immediately by centrifugation at $1,850 \times g$ for 10 min at 4°C and stored at -20°C.

Laboratory Analysis

Feed, feed refusals, and fecal samples were thawed at room temperature then dried at 55°C forced air oven (Thermo Scientific Precision 645, Danville, IN) and ground through a 1-mm screen in a Wiley mill (Arthur H. Thomas, Philadelphia, PA). Ground feed, feed refusals, and feces were analyzed in duplicate for DM, ash, total Kjeldahl N (AOAC, 1984a), NDF (heat stable α -amylase and Na_2SO_3 were used), and ADF according to Van Soest et al. (1991a). Ground feed, feed refusals, and total collection fecal samples were ground further through a 0.2 mm screen (Z-grinder) and analyzed for total P and inorganic P (**Pi**) using the yellow

molybdovanadate method and molybdate blue method (AOAC, 1984a). Milk samples were analyzed for fat, protein, lactose, milk urea nitrogen (MUN), somatic cell count (DHIA, Blacksburg, VA), and total P. Concentration of serum Pi was analyzed in a 96-well plate using the spectrophotometer (Eon™ Microplate Spectrophotometer, BioTek Instruments Inc.). An aliquot of digested solution of feed, feces and milk samples for total P were analyzed for Ca or Fe using Inductively Coupled Plasma Atomic Emission Spectroscopy (CirOS VISION model, SPECTRO Analytical Instruments Inc., Mahwah, NJ).

Feed samples were composited by period and feces samples composited by cow × period for inositol hexaphosphate (IP6) analysis following the method of Ray et al. (2012a). Briefly, 0.25 M NaOH-0.05 M EDTA were used to extract dried ground samples and then extracts were acidified with HCl-HF acid solution (500 µl of 6 M HCl and 1.2 M HF added to 5 ml sample extract). Acidified extracts were stored overnight at 4°C and then centrifuged at 30,000 × g for 20 min at 4°C. Clear supernatants were passed through methanol-conditioned C-18 columns (Sep-Pakplus, Waters, MA) and a 0.2 µm IC membrane (PTFE filter; IC Millex-LG, Fisher, PA) continuously into Dionex sample vials (Dionex, Sunnyvale, CA) for HPIC analysis.

Statistical Analysis

All data were analyzed using PROC GLIMMIX procedures of SAS (SAS Institute., 2008) with the model:

$$Y_{ijk} = \mu + T_i + P_j + C_k + \epsilon_{ijk}$$

where

μ = overall mean,

T_i = fixed effect of period (i=1 to 4),

P_j =fixed effect of period (j = 1 to 4),

C_k = random effect of cow ($k = 1$ to 4), and

ε_{ijk} =residual error.

The random effect of cow was used to test treatment effects and preplanned contrasts were used to evaluate linear and quadratic treatment effects of treatment. Differences were declared significant at $P < 0.05$ and trends at $P < 0.10$. Results are reported as least square means.

Results and Discussion

Dry Matter Intake and Digestibility

Effects of treatment on DMI were not observed (Table 2). Infusion of ferrous lactate into abomasum did not affect NDF or nitrogen intake (Table 2). However, digestibility of DM, NDF, and nitrogen were all decreased linearly with increasing amount of abomasal infusion of ferrous lactate ($P < 0.01$; Table 2). Similarly, DMI was not affected with available Fe 58 to 66 mg/kg DM from feedstuffs and supplemental organic Fe-amino acid complex (Weiss et al., 2010); assuming the 0.1 absorption coefficient assigned by the NRC (2001), available Fe from diet plus infusate in the current study ranged approximately from 65 to 120 mg/kg DM.

The reductions in NDF, nitrogen, and DM digestibility with increasing doses of infused ferrous lactate may be due to alterations in the microbial population of the large intestine. Excessive iron supplementation or iron contamination of feeds has been shown to decrease microbial activity in the rumen, adversely influencing ruminal digestive processes (Hubbert et al., 1958). Martinez and Church (1970) tested effects of iron addition on *in vitro* rumen cellulose digestion and observed that 100 mg/L Fe in the incubation medium caused a 25% decrease of cellulose digestibility compared to controls. Similarly, with supplemental Fe between 100 and 1000 mg/L of *in vitro* culture medium, DM digestion was decreased by up to 36% compared to controls (Harrison et al., 1992). In the current study, increasing available iron in the digestive

tract may have caused a similar adverse effect on the microbial population in the large intestine as observed in these studies focused on the rumen bacteria, explaining the negative impact of Fe infusion on total tract nutrient digestion. Alternatively, iron toxicity has been shown to cause diarrhea (NRC, 2001), which may increase the passage rate of the feed in digestive tract, thus reducing total tract nutrient digestibility.

Phosphorus Intake and Absorption

No effects of treatment on intake or apparent total tract digestion of total P, Pi, or phytate were observed (Table 3). While high Fe intake has been shown to reduce P availability in chicks (Deobald and Elvehjem, 1935) and piglets (Furugouri, 1972), research examining the impact of iron intake on P utilization in dairy cattle is scarce. Iron phosphate complexes precipitate out in the intestinal tract reducing iron availability (Miller, 1981), thus the availability of phosphate is reduced too. It has been suggested that increasing dietary P might be an efficient way to prevent iron toxicity (Standish et al., 1971, Rosa et al., 1982). In growing lambs consuming a low Ca and P diet, high dietary Fe (350 and 600 mg/kg vs. 100 mg/kg in basal diet) had no negative effects on apparent absorption and retention of P (Haro et al., 2009). Cattle grazing pastures maybe exposed to high iron through forage or soil ingestion (Spears, 2009), posing a potential threat to the utilization of dietary P, but the current study provides no evidence of negative impact of available Fe on P absorption.

Concentration of serum Pi was in the normal range (6.07-6.82 mg/dl) and not affected by treatment, further evidence of the lack of effect of infused iron on absorption of P. In lambs, supplementation of 1200 mg Fe/kg as ferrous carbonate decreased plasma P concentration slightly and reduced Cu stores, Cu transport, and storage protein without affecting bone ash (Prabowo et al., 1988). In calves, increasing dietary supplementation of ferric citrate (from 100

to 2000 mg/kg) decreased plasma Pi without affecting weight gain and feed intake (Koong et al., 1970). In steers, plasma Pi was lower (4.0 vs. 6.9 mg/dl) after 45 d of feeding 1000 mg Fe/kg DM than when feeding 100 mg Fe /kg DM (Standish et al., 1971), but increasing P supplementation (0.46% vs. 0.23%) reduced the detrimental effect of excessive iron (less dark rumen color) indicating the interaction of the two elements. The current study supplied much less available Fe than the steer study (120 mg available Fe/kg DM in highest supplemental level vs. 1000 mg Fe/kg DM in (Standish et al., 1971).

Mineral-phytate complexes are resistant to hydrolysis by phytases (Maenz et al., 1999). Ferrous iron is second to Zn in inhibitory potency to phytase hydrolysis at neutral pH; ferric iron ranks fourth. Insoluble complexes formed from phytic acid and Fe are not available for absorption under the pH conditions of the small intestine (Minihane and Rimbach, 2002). A portion of phytate flowing to the large intestine of dairy cattle is digested by the microbes residing there (Ray et al., 2012c). We expected infused Fe would decrease phytate degradability to some extent in the large intestine, thus decreasing total tract phytate digestibility. Despite a tendency for phytate in feces to decrease ($P=0.08$) with increasing Fe infusion, the magnitude of the change was small and phytate digestibility was not significantly affected by treatment. Bremner and Dalgarno (1973) observed lower availability of Fe from iron phytate than from three soluble sources (FeSO₄, ferric citrate and ferric-EDTA) in calves with no differences between the three soluble Fe sources. Moderate anemia was also observed in calves given iron phytate.

Milk Production and Composition

Milk yield, milk protein, milk lactose, SCC, and MUN were unaffected by treatment (Table 4). A quadratic effect of treatment on milk fat was observed ($P=0.04$; Table 4) but the

magnitude of the change was small. Iron infusion did not affect concentration of P or Fe in milk. Others have also observed no change in milk yield or composition with supplementation of 30 mg Fe/kg DM (Weiss et al., 2010) or 500 mg Fe/kg DM (Chase et al., 2000). Lowered milk and fat production in dairy cattle dosed orally with 30 to 60 g iron per day in the form of ferric hydroxide (Coup and Campbell, 1964) was reported. Water intake was not monitored but water Fe of the magnitude of current study might reduce water intake due to palatability, thus affecting production. Genter (2011) reported lowered water intake by lactating cows with 8 mg Fe/L drinking water.

In this short term study there was no evidence of the impacts of Fe on oxidative stress or health. Excessive free iron not bound to iron transport proteins catalyze the decomposition of hydrogen peroxide (Fenton reaction) leading to reactive oxygen species (ROS) which damage biomolecules, including lipids, proteins and DNA (Jomova and Valko, 2011). Iron binding ability is important to prevent Fe from catalyzing the production of hydroxyl radicals indicating lowered unsaturated iron-binding capacity is detrimental. Cows fed excessive dietary Fe and cows with retained fetal membranes (**RFM**) both had lower unsaturated iron-binding capacity (Campbell and Miller, 1998) implying an indirect relationship of excess Fe intake and RFM.

Oxidative stress is a primary factor predisposing cows to mastitis (Ghasemian Karyak et al., 2011). With increasing doses of iron infusion, milk SCC was not affected suggesting infusion of 1250 mg Fe/d was safe to early lactating dairy cattle. In the study of Weiss et al. (2010), cows receiving supplemental Fe (30 mg/kg) had lower SCC (log₁₀cells/ml) than controls (4.37 vs. 4.62) but the magnitude of the response was so low as to have little economic significance.

Conclusions

Abomasal infusion of up to 1250 mg Fe/d from ferrous lactate in early lactation cows fed Fe adequate diets did not affect DMI, P intake, P absorption, milk composition, or milk production. However, digestibility of DM, NDF and nitrogen were decreased with increasing Fe infusion. In the short term, water iron up to 12.5 mg/L did not affect production or P status of lactating cows.

References

- AOAC. 1984. Official Methods of Analysis. 14th ed. Asso. Off. Anal. Chem. Arlington, VA.
- Beede, D. K. 2005. Assessment of Water Quality and Nutrition for Dairy Cattle in Mid-South ruminant nutrition conference. Arlington, TX.
- Bremner, I. and A. C. Dalgarno. 1973. Iron metabolism in the veal calf. The availability of different iron compounds. *Br. J. Nutr.* 29:229.
- Bullen, J. J., H. J. Rogers, and E. Griffiths. 1978. Role of iron in bacterial infection. *Curr Top Microbiol Immunol* 80:1-35.
- Campbell, M. H. and J. K. Miller. 1998. Effect of supplemental dietary vitamin E and zinc on reproductive performance of dairy cows and heifers fed excess iron. *J Dairy Sci* 81:2693-2699.
- Chase, C. R., D. K. Beede, H. H. Van Horn, J. K. Shearer, T. C. J. Wilcox, and G. A. Donovan. 2000. Responses of lactating dairy cows to copper source, supplementation rate, and dietary antagonist (iron). *J Dairy Sci* 83:1845-1852.
- Coup, M. R. and A. G. Campbell. 1964. The effect of excessive iron intake upon the health and production of dairy cows. *Journal of Agricultural Research* 7:15.
- Deobald, H. J. and C. A. Elvehjem. 1935. The effect of feeding high amounts of soluble iron and aluminum salts. *American Journal of physiology* 111:118-123.
- Frazer, D. M. and G. J. Anderson. 2005. Iron imports. I. Intestinal iron absorption and its regulation. *Am J Physiol Gastrointest Liver Physiol* 289:G631-635.
- Furugouri, K. 1972. Effect of elevated dietary levels of iron on iron store in liver, some blood constituents and phosphorus deficiency in young swine. *J Anim Sci* 34:573-577.

Genther, O. N. 2011. Investigation of iron concentration, valence, and source effects on short-term iron(Fe) status and drinking water preference of lactation dairy cows. in *Animal Science*. Vol. M.S. Michigan State University.

Ghasemian Karyak, O., S. Safi, A. Rahimi Froushani, and M. Bolourchi. 2011. Study of the relationship between oxidative stress and subclinical mastitis in dairy cattle. *Iranian Journal of Veterinary Research* 12:350-353.

Haro, I. M., R. D. Brink, and J. M. Haro. 2009. Effects of Inclusion of Different Levels of Iron in Lamb Diets on Apparent Absorption and Retention of Phosphorus. *Journal of Animal and Veterinary Advances* 8:19-22.

Harrison, G. A., K. A. Dawson, and R. W. Hemken. 1992. Effects of high iron and sulfate ion concentrations on dry matter digestion and volatile fatty acid production by ruminal microorganisms. *J Anim Sci* 70:1188-1194.

Hubbert, F., J. E. Cheng, and W. Burroughs. 1958. Mineral requirement of rumen microorganisma for cellulose digestion *in vitro*. *J. Anim. Sci.* 17:559-568.

Jomova, K. and M. Valko. 2011. Importance of iron chelation in free radical-induced oxidative stress and human disease. *Curr Pharm Des* 17:3460-3473.

Koong, L. J., M. B. Wise, and E. R. Barrick. 1970. Effect of elevated dietary levels of iron on the performance and blood constituents of calves. *J Anim Sci* 31:422-427.

Maenz, D. D., C. M. Engele-Schaan, R. W. Newkirk, and H. L. Classen. 1999. The effect of minerals and mineral chelators on the formation of phytase-resistant and phytase-susceptible forms of phytic acid in solution and in a slurry of canola meal. *Animal Feed Science and Technology* 81:177-192.

Martinez, A. and D. C. Church. 1970. Effect of various mineral elements on *in vitro* rumen cellulose digestion. J Animal Sci. 31:982-990.

McGuire, S. O., W. J. Miller, R. P. Gentry, M. W. Neathery, S. Y. Ho, and D. M. Blackmon. 1985. Influence of high dietary iron as ferrous carbonate and ferrous sulfate on iron metabolism in young calves. J Dairy Sci 68:2621-2628.

Miller, W. J. 1981. Mineral and vitamin nutrition of dairy cattle. J Dairy Sci 64:1196-1206.

Minihane, A. M. and G. Rimbach. 2002. Iron absorption and the iron binding and anti-oxidant properties of phytic acid. International Journal of Food Science and Technology 37:741-748.

NRC. 2001. Nutrient Requirements of Dairy Cattle. 7th rev. ed. ed. Natl. Acad. Press, Washington DC.

Prabowo, A., J. W. Spears, and L. Goode. 1988. Effects of dietary iron on performance and mineral utilization in lambs fed a forage-based diet. J Anim Sci 66:2028-2035.

Ray, P. P., C. Shang, R. O. Maguire, and K. F. Knowlton. 2012a. Quantifying phytate in dairy digesta and feces: alkaline extraction and high-performance ion chromatography. J Dairy Sci 95:3248-3258.

Ray, P. P., C. Shang, R. E. Pearson, and K. F. Knowlton. 2012b. Disappearance of infused phytate from the large intestine of dairy heifers. J Dairy Sci 95:5927-5935.

Rosa, I. V., P. R. Henry, and C. B. Ammerman. 1982. Interrelationship of dietary phosphorus, aluminum and iron on performance and tissue mineral composition in lambs. J. Animal Sci. 55:1231-1240.

SAS Institute. 2008. SAS/STAT[®] 9.2 User's Guide. Cary, NC: SAS Institute Inc.

Socha, M. T., S. M. Ensley, D. J. Tomlinson, and A. B. Johnson. 2003. Variability of water composition and potential impact on animal performance. Proc. Intermountain Nutr. Conf. pp 85-96.

Spears, J. 2009. Trace Mineral Nutrition-What is Important and Where do Organic Trace Minerals Fit in?

Standish, J. F., C. B. Ammerman, A. Z. Palmer, and C. F. Simpson. 1971. Influence of dietary iron and phosphorus on performance, tissue mineral composition and mineral absorption in steers. J Anim Sci 33:171-178.

Standish, J. F., C. B. Ammerman, C. F. Simpson, F. C. Neal, and A. Z. Palmer. 1969. Influence of graded levels of dietary iron, as ferrous sulfate, on performance and tissue mineral composition of steers. J Anim Sci 29:496-503.

Thomas, J. W. 1970. Metabolism of iron and manganese. J. Dairy Sci. 53:1107.

Underwood, E. J. and N. F. Suttle. 1999. The mineral nutrition of livestock. 3rd ed. CABI, New York.

Van Soest, P. J., J. B. Robertson, and B. A. Lewis. 1991. Methods for dietary fiber, neutral detergent fiber, and nonstarch polysaccharides in relation to animal nutrition. J Dairy Sci 74:3583-3597.

Weiss, W. P., J. M. Pinos-Rodriguez, and M. T. Socha. 2010. Effects of feeding supplemental organic iron to late gestation and early lactation dairy cows. J Dairy Sci 93:2153-2160.

Table 3-1 List of ingredients of diet

Item	% of DM
Corn silage	40.4
Grass hay, mid bloom	14.0
Dry ground corn grain	12.4
Grass/legume mix silage	6.1
Wet brewer's grain	3.31
Hominy feed	4.20
Soybean meal (48% CP)	6.95
Cottonseed meal	4.15
Mineral and vitamin mix ¹	2.57
Pro-Lak ³	2.12
Wheat middlings	1.74
Dehydrated molasses	0.92
Bentonite	0.48
Animal fat	0.46
Urea	0.23

¹Mineral and vitamin mix (DM basis):limestone 41.51%; sodium bicarbonate 22.64%; magnesium oxide 7.46%; Dynamate 11.2%; Salt-white 11.3%; Availa-4 2.11%; Selenium (0.06%) 1.14%; Vit. E-60000 0.59%; Rumensin 90 0.22%; Vit ADE 1.79%.

²Total ration formulated nutrient concentrations (DM basis) were:NE_L, 1.60 Mcal/kg; CP 15.0%; NDF 34.7%; ADF 17.5%; Ca 0.66%; P, 0.39%; Fe 651 mg/kg.

³Dairy by-pass protein supplement, H. J. Baker & Bro., Inc. Westport, CT

Table 3-2 Effect of abomasal infusion of ferrous lactate on nutrient intake and digestibility

Item	Iron in infused solution, mg/L				SE	<i>P</i> -value		
	0	200	500	1250		Trt	Linear	Quad
DMI, kg/d	23.1	22.3	23.1	22.7	0.43	0.27	0.67	0.98
Feces DM, kg/d	7.25	6.92	7.62	7.48	0.28	0.05	0.92	0.34
DM digestibility, %	68.5	69.0	67.0	67.0	0.76	0.01	0.007	0.18
NDF intake, kg/d	8.01	7.73	7.99	7.84	0.15	0.28	0.66	0.97
NDF digestibility, %	38.2	38.3	36.2	36.2	0.79	0.01	0.006	0.08
Nitrogen intake, g/d	552	533	551	541	10	0.24	0.65	0.98
Nitrogen digestibility, %	66.4	66.2	64.7	64.1	0.70	0.005	0.001	0.14

Table 3-3 Effect of abomasal infusion of ferrous lactate on intake and digestibility of total P, Pi and phytate

Item	Iron in infused solution, mg/L				SE	P-value		
	0	200	500	1250		Trt	Linear	Quad
Total P								
Intake, g/d	90.9	87.9	90.7	89.1	1.64	0.25	0.65	0.97
Fecal, g/d	51.4	49.9	53.4	52.3	1.24	0.13	0.22	0.30
Apparent total tract digestibility, %	43.5	43.2	41.2	41.4	1.14	0.41	0.20	0.39
Pi								
Intake, g/d	46.0	44.8	46.0	45.4	0.81	0.32	0.74	0.97
Fecal, g/d	35.6	34.1	36.6	36.8	1.03	0.32	0.22	0.94
Apparent total tract digestibility, %	22.5	23.0	20.2	20.0	2.49	0.80	0.48	0.77
Serum Pi, mg/dl	6.77	6.07	6.82	6.51	0.38	0.45	0.99	0.97
Phytate								
Intake, g/d	35.6	34.3	35.6	34.9	0.70	0.27	0.69	0.94
Fecal, g/d	1.01	0.96	0.91	0.87	0.10	0.27	0.08	0.41
Total tract digestibility, %	97.2	97.2	97.5	97.5	0.24	0.22	0.08	0.40

Table 3-4 Effect of abomasal infusion of ferrous lactate on milk yield and composition

Item	Iron in infused solution, mg/L				SE	<i>P</i> -value		
	0	200	500	1250		Trt	Linear	Quad
Milk yield, kg/d	31.6	31.6	32.0	31.5	1.15	0.95	0.88	0.65
Milk fat, %	5.19	5.10	5.08	5.15	0.52	0.16	0.87	0.04
Milk protein, %	3.37	3.25	3.34	3.36	0.16	0.50	0.66	0.54
Lactose %	4.79	4.83	4.77	4.79	0.13	0.46	0.66	0.83
MUN, mg/dl	12.9	13.3	13.7	13.3	0.71	0.47	0.48	0.18
SCC, log ₁₀ (cells/ml) ¹	4.65	4.59	4.83	4.81	0.29	0.51	0.29	0.60
Milk P, mg/g	0.99	0.98	1.00	0.97	0.03	0.69	0.77	0.46
Milk Fe, mg/kg	1.09	1.49	1.28	1.20	0.18	0.45	0.88	0.36

¹Milk SCC (cells/ml) was log₁₀transformed to normalize the data.

Chapter 4 EFFECT OF DIETARY P ON INTESTINAL P ABSORPTION IN GROWING HOLSTEIN STEERS

Feng, X., H. Schramm, E. Ronk, M. McCann, M. D. Hanigan, and K. Knowlton. 2015. Effect of different dietary phosphorus on intestinal P absorption on growing Holstein steers. *J. Dairy Sci.* 98 (5):3410-3416.

* Used by permission of the Journal of Dairy Scienc

Abstract

The effect of dietary phosphorus (P) intake on intestinal P absorption was evaluated in growing Holstein steers. Diets varying in P content (0.15%, 0.27%, 0.36% and 0.45%, DM basis) were fed to 8 steers (174 ± 10 kg BW) fitted with permanent duodenal and ileal cannulas in a replicated 4×4 Latin square with 14 d periods. Ytterbium-labeled corn silage and cobalt-EDTA were used as particulate and liquid phase markers, respectively, to measure digesta flow. Duodenal and ileal samples and spot urine samples were collected every 9 h from d 11 to 14. Total fecal collection was conducted on d 11 to 14 with fecal bags. Blood samples were collected from the coccygeal vessel on d 14. Feed, digesta, and fecal samples were analyzed for total P and inorganic P (Pi). Data was analyzed using PROC GLIMMIX in SAS with a model including treatment, square, period and interaction of treatment and square. Preplanned contrasts were used to evaluate linear and quadratic treatment effects. Results were reported as least square means. Dry matter intake (mean = 4.90 kg/d, 2.8% of BW) and apparent DM digestibility (mean = 78.1%) were unaffected by treatment. Duodenal and ileal flow of total P increased linearly with increasing P intake (13.4, 18.5, 23.0 and 27.4 g/d; 6.80, 7.87, 8.42, and 10.4 g/d). Increasing P intake increased the quantity of P absorbed from the small intestine linearly (6.96, 11.1, 14.6 and 17.2 g/d) but absorption efficiency was unchanged (mean = 59.6%). Phosphorus was absorbed on a net basis from the large intestine, but this was not affected by treatment and was a small proportion of total P absorption. Blood Pi increased linearly with increased dietary P (4.36, 6.31, 7.68, and 8.5 mg/d) and salivary P secretion was unchanged (mean = 5.79 g/d) suggesting that rumen function was prioritized during short-term P deficiency. These data showing an absence of change in absorption efficiency and salivary P secretion in the face of short term P deficiency may be used to improve published models of P digestion, absorption, and metabolism.

Key Words: phosphorus, digestion and absorption, Holstein steer

Introduction

Manure P contamination of surface water can impair the growth and survival of aquatic species. The strong relationship between dietary P and manure P content in most species (Erickson et al., 1999, Knowlton and Herbein, 2002, Wu et al., 2003) makes dietary nutrient management a useful approach to reduce the environmental impact of livestock farms, but also makes important detailed knowledge of the fate of the dietary P and its utilization in the digestive tract. In ruminants, absorption of P is modulated by endocrine and nutritional factors such as mineral content of the diet, P content of the diet and the forms of P in the diet (Field et al., 1983, Scharrer, 1985, Care, 1994).

In both ruminants and non-ruminants, the major site for P absorption is the small intestine. In non-ruminants there are two mechanisms of P absorption: a vitamin D-dependent active transport which dominates at low concentrations of P in the intestinal contents, and passive absorption which plays an important role with greater dietary P supply (Wasserman and Taylor, 1976, NRC, 2001). Whether similar processes are dominant in ruminants is unclear. The general form of the relationship between supply and absorption of P is that increasing P flow decreases absorption efficiency, suggesting that a carrier-mediated system might be involved, at least in sheep (Scott et al., 1984). Care et al. (1980) indicated active transport was involved in P absorption in sheep based on the evidence that total P absorbed reached plateau when the P content of a perfusate was increased to 15 mmol/L. P absorption in small intestine is also related to age, physiological state, and unexplained animal-to-animal variation (Field et al., 1983).

Most of the inorganic P (Pi) absorbed is from the small intestine, though at higher intake of P some net absorption of Pi also occurs from the large intestine (Care, 1994). Net absorption

of P from the large intestine in sheep ranges from 2 to 30% of the P flow entering the large intestine (Breves and Schroder, 1991). The absorption of Pi from the large intestine is concentration-dependent and may change from net absorption to net secretion with higher P intake (Breves et al., 1985). Holler et al. (1988) reported net Pi secretion into the colon with a Pi-free infusate into the colon of sheep and net Pi uptake with an infusate containing 2.5 to 6.5 mmol/L of Pi. In addition, inorganic P can be released within the large intestine by microbial degradation of phytate as occurs in the rumen (Ray et al., 2013). The effect of dietary P on absorption of P from the small and large intestines of cattle is rarely reported but is important in efforts to optimize P feeding and reduce P runoff from farms. Our objective was to estimate effects of dietary P on intestinal P absorption in growing Holstein steers.

Materials and Methods

The trial was conducted at Virginia Tech Dairy Center under the approval of the Institutional Animal Care and Use Committee, Virginia Polytechnic Institute and State University, Blacksburg, Virginia (13-006-DASC).

Animals

Holstein steer calves (3 to 4 months old) were purchased directly from a commercial dairy farm. Before transport, steers were vaccinated with Bovi-shield Gold and Ultrabac-7 (Zoetis Inc., Florham Park, NJ) and tested for Bovine Viral Diarrhea with an ear notch sample. Steers were halter trained and then dehorned using cauterization. After the calves fully recovered from dehorning, T-shaped cannulas were inserted to the duodenum and ileum. Cannulas were made from Tygon (barrel part) and vinyl tubing (flange part) and the pieces were connected using cyclohexane. The duodenal cannula was placed ~5 cm from the pyloric sphincter, and the ileal cannula was placed ~5 cm from the ileo-cecal junction. Surgeries were done with the animal

in lateral recumbent position using intravenous anesthesia. Steers recovered fully from surgery before initiation of the experiment. Throughout the experiment no blockage was encountered in either the duodenal or ileal cannulas and there was no evidence of the cannulas adding significant resistance to digesta flow.

Experimental Design and Sampling

Eight duodenally- and ileally-cannulated Holstein steers averaging 173.7 ± 9.5 kg at 6 months of age were used in a replicated 4×4 Latin square design with 14 day periods. The basal diet was formulated to meet all nutrient requirements except P (NRC, 1996). Assuming the same P requirements for these steers as for growing beef steers (16 mg of P /kg BW for maintenance plus 3.9 g of P /100 g of protein gain; NRC 1996), the basal diet (0.15% P) provided 56% of P requirements. The basal diet was supplemented with monoammonium phosphate (MAP) to obtain dietary P concentration of 0.27%, 0.36% and 0.45% to provide an estimated 100, 133 and 167% of the P requirement. Extra N provided with MAP supplementation was equalized among the treatment groups with trace amounts of urea. Steers were housed in individual stalls (1.25×2.25 m) and fed once daily at 1200 h on d 1 to 7 and four times daily at 0600, 1200, 1800 and 2400 h on d 8 to 14 of each period. Steers had continuous access to feed and water during the experiment. Ytterbium (Yb) labeled corn silage (Harvatine et al., 2002) and Co-EDTA (Scott et al., 1985) were dosed at 120 mg/d as particulate and liquid phase markers, respectively, to estimate digesta flow. Markers were mixed into the TMR for dosing at each feeding on d 8 to 14 of each period.

Feed and feed refusals were sampled daily and stored at -20°C . Starting from 1800 h on day 11 of each period, about 200 ml of duodenal contents and 100 ml of ileal contents were collected from each steer every 9 h, with sampling times advanced by 3 h each day to account for

diurnal variation. Removal of the duodenal cannula plug often resulted in an initial surge of duodenal digesta. This initial surge was discarded and digesta from subsequent flow was retained and frozen at -20°C . Total fecal collection was conducted on d 11 to 14 of each period with fecal bags (Tolleson and Erlinger, 1989) and the bags were emptied twice daily. Fecal contents were thoroughly mixed daily and a subsample was collected and frozen at -20°C . Blood samples were obtained on d 14 of each period from the coccygeal vessel and saved in Vacuette tubes (Greiner Bio-one, Monroe, NC). Serum was separated by centrifugation at $1,850 \times g$ for 10 min at 4°C and stored at -20°C .

Laboratory Analysis

Feed, feed refusals, composited ileal samples (by steer within period), and fecal samples were thawed at room temperature then dried at 55°C in a forced air oven (Thermo Scientific Precision 645, Danville, IN) and ground through a 1-mm screen in a Wiley mill (Arthur H. Thomas, Philadelphia, PA). Ground feed and feed refusals were analyzed in duplicate for total Kjeldahl N (AOAC, 1984b), NDF (heat stable α -amylase and Na_2SO_3 were used) and ADF according to Van Soest et al. (1991b), total P and Pi using the yellow molybdovanadate method and molybdate blue method (AOAC, 1984b), and for Co and Yb using ICP-MS (Harvatine et al., 2002). Ground ileal and fecal samples were analyzed for total P, Pi, Co and Yb with the same methods as for feed and refusals.

Due to the non-homogenous nature of the duodenal digesta, the composited duodenal samples (by steer within period) were separated into two phases as described in Ahvenjarvi et al. (2000). Briefly, samples were centrifuged at $1,000 \times g$ (5°C , 5 min) and the supernatant was decanted and defined as the duodenal fluid phase. The pellet was defined as the duodenal particle phase. The separated phases were frozen, freeze-dried (FreezeZoneBenchtop, Labconco, Kansas

City, MO), and ground through a 1-mm screen in a Wiley mill (Arthur H. Thomas, Philadelphia, PA) or freezer mill (SPEX 6850 Freezer Mill; SPEX CertiPrep Inc., Metuchen, NJ) for analysis of total P, Pi, Co and Yb (same methods as described previously). Flow of P into and out of the small intestine was estimated with the double marker method presented in France and Siddons (1986). Concentration of serum Pi was analyzed by measuring the formed phosphomolybdate complex in a spectrophotometer (Eon Microplate Spectrophotometer; BioTek Instruments Inc., Winooski, VT).

Statistical Analysis

Data analysis was performed using PROC GLIMMIX in SAS (SAS Institute., 2008). The effects of treatment, period, square and interaction of treatment and square were included in the model as fixed effects. Preplanned contrasts were used to evaluate linear and quadratic treatment effects. Due to the unequal space between the treatments (dietary P %), the polynomial coefficients for the linear and quadratic effects were obtained with PROC IML. Differences were declared significant at $P < 0.05$ and trends at $P < 0.10$. Results were reported as least square means.

Results and Discussion

Diets, DMI, and Digestibility

Ingredient and nutrient composition of diets are listed in Table 1. Dietary P did not affect intake of DM, NDF, or N (Table 2). In contrast, Wise et al. (1958) observed that in Holstein male calves (average BW 110.3 ± 7.4 kg) feed consumption was directly related to dietary P with calves fed a low P diet (45% of P requirement) consuming about 78% of the feed consumed by calves fed sufficient P. Similarly, Gartner (1982) found that feed intake of Hereford heifers (378 ± 21.4 kg) was reduced by 13% when diet providing 50% of the P requirement as compared to

100% of requirement. In Holstein bull calves increasing dietary P from 0.26 to 0.34% increased feed intake but no further increase was observed from 0.34 to 0.41% (Jackson et al., 1988). The decreased DMI at very low P intake is usually attributed to compromised rumen microbial function.

There was a tendency for DM digestibility to be different ($P = 0.07$), increasing slightly in steers fed 0.27% P. While P is required by rumen microbes for efficient cellulose digestion (Field et al., 1983), the reason for elevation in DMD at this mid-range treatment (rather than simply a depression at low P compared to all others) was unclear. Chicco et al. (1965) suggested that at least 60 mg of available P/L of medium was required to maximize cellulose disappearance. In a continuous rumen incubation system, cellulose digestion and volatile fatty acid production decreased when P_i concentration was lowered to 0.1 mM while microbial protein synthesis was reduced at P_i concentrations of less than 0.03 mM (Komisarczuk et al., 1987). These changes in microbial metabolism need to be considered when interpreting the effects of P deficiency. In the current study, the lack of clear detrimental effects of low P intake maybe due to the short duration of the study. In the short term, bone mobilization may ameliorate the low P concentration in the plasma to minimize the side effects of low dietary P. This is similar to observations in studies with lactating cows (Guyton et al., 2003b, Puggaard et al., 2011) and steers (Erickson et al., 2002). In studies showing negative impacts, the P supply was extremely low (45% of P requirement, (Wise et al., 1958) or the deficiency was over an extended period of time (lactating cows fed 0.31%P for two to three lactations, (Wu et al., 2001).

Digestion and Absorption of P in Digestive Tract

Phosphorus Intake and Digestibility As expected, intake of total P and P_i were linearly increased with increasing dietary P (Table 3). There was a quadratic effect of dietary P on

apparent P digestibility with steers fed the basal diet (0.15% P) having the lowest apparent P digestibility (21.9, 51.4, 57.5, and 59.5%; $P < 0.01$). Reduced apparent P digestibility at higher P intake is the more usual observation but it is not universal (Guyton et al., 2003b). Geisert et al. (2010) observed that steers fed diets with 0.12% P had apparent P digestibility of just 11.3%. Ternouth (1990) suggested that slight reduction in apparent P digestibility at low P intake may be due to compromised microbes in the cecum/colon rather than the rumen; it is relatively difficult to reduce ruminal P concentration enough to depress microbial activity there. Another explanation is that salivary P was a greater proportion of P entering the digestive tract in this treatment. This could reduce the estimate of apparent digestibility of dietary P.

Phosphorus Absorption from the Small Intestine Because of salivary P recycling, duodenal P flows were greater than P intake in all treatment groups (Table 3). Total P absorbed from the small intestine was linearly increased with increasing P flow to the duodenum with absorbed P as a proportion of duodenal P flow unaffected (Table 3). The mechanisms of P absorption are little studied in ruminants. In monogastrics, Breves and Schroder (1991) reported two mechanisms of P transport in the small intestine: a passive non-saturable mechanism and a secondary, active Na-coupled mechanism which is controlled by 1,25-(OH)₂D₃. Sabbagh et al. (2009) clarified this, observing that in mice, intestinal phosphate absorption occurs through both a paracellular mechanism involving tight junctions and an active transcellular mechanism involving the type 2 sodium-dependent phosphate co-transporter. In sheep, the upper small intestine is the major absorptive site with both active transport and passive diffusion mechanisms (Care, 1994). With perfusion of the temporarily-isolated upper small intestine with NaH₂PO₄ (5 to 50 mmol/L), Scott et al. (1984) reported a curvilinear relationship between P absorption and P concentration; absorption efficiency fell from 0.74 at 5 mmol/L to 0.35 at 50 mmol/L. It was also

reported that in sheep, as dietary P increased from 2.5 to 5.0 g/kg of DM, total P absorbed increased but efficiency of absorption was constant (Bravo et al., 2003a, 2003b). Combined, these studies support the conclusion that, in general, increasing P flow into the duodenum increases P absorption without changes in absorption efficiency. Under higher dietary P intake, high blood P concentration could slow down the passive transport and the upper limit of active transport could also be saturated.

Phosphorus Absorption from the Large Intestine No treatment effect on P absorption from large intestine was observed and net secretion was observed for all treatments (Table 3). This is likely due to the microbial degradation of organic P compounds and/or the degradation of microbial P in large intestine. In ruminants the large intestine plays a much smaller role on P absorption than the small intestine. There is some evidence, however, that the colon may be an important site for P absorption in pre-weaned ruminants. Scharrer (1985) observed the same phosphate absorption efficiency from the descending colon as the upper and mid-jejunum in young lambs.

Fecal P Excretion

Total fecal P excretion tended to increase linearly with increasing dietary P intake (Table 3). Increased fecal P excretion with increasing dietary P has been reported in lactating dairy cows (Wu et al., 2000, Knowlton and Herbein, 2002) and steers (Geisert et al., 2010). Interestingly, Witt and Owens (1983) reported that two out of six steers fed a low P diet (0.12%) excreted more P in feces than they consumed during short period of P deficiency. This implies that bone P or tissue P may be mobilized allowing the animal to endure intermittent periods of P deficiency.

Salivary P Secretion

In the current study, salivary P was not affected by treatment (Table 3). Salivary P was estimated as the difference between duodenal P flow and P intake (Scott et al., 1984, Scott and Buchan, 1987, Bortolussi et al., 1996). In monogastrics, the kidneys are most important in removing excess P from the blood, while, in ruminants, the salivary glands play this role (Care, 1994). The salivary glands of cattle can concentrate plasma P from 3- to 8-fold depending on salivary flow rate and plasma P concentration (Ternouth et al., 1985). Low P intake does not necessarily result in low salivary P secretion. Puggaard et al. (2011) demonstrated that low P intake (0.24%) did not diminish salivary P flux in lactating dairy cows suggesting that rumen microbe function was prioritized at low P intake with bone P probably mobilized to maintain salivary P recycling. The results of the current study are consistent with this “rumen support” theory of Puggaard et al. (2011).

Serum Pi and Urinary P

Consistent with most reports (Wu et al., 2000, Puggaard et al., 2011), serum Pi concentration at low P intake was depressed compared to higher P intake and increased linearly with increasing P intake (Table 3). Serum Pi less than 4 mg/dL is generally seen as an indicator of P deficiency (Erickson et al., 2002). By mobilizing P from bone, ruminants appear to have the ability to buffer effects of dietary P on the blood P pool.

Urinary P concentration were unaffected by treatment ($P = 0.24$, Table 3) but tended to increase with increasing dietary P intake ($P = 0.06$, Table 3). Due to experimental limitations (no total collection of urine), urinary P excretion could not be calculated. Observed urinary P concentrations were in the range of that observed in heifers (average 0.88 to 16.47 mg/dL; unpublished data from other studies in our lab). Urinary P excretion is highly variable among

different species and between animals in the same species (3.4 to 18.2 g/d; (Geisert et al., 2010). In dairy cattle, urinary P excretion is negligible compared to fecal P excretion (Puggaard et al., 2011) and the kidneys do not contribute significantly to the overall regulation of P homeostasis in ruminants (Breves and Schroder (1991) .

Conclusions

Absorption efficiency of P from the small intestine by growing Holstein steers on a high beet pulp diet supplemented with MAP was unchanged despite the short term P deficiency suggested by reduced serum Pi. Likewise, salivary P secretion was unchanged. Thus we conclude that rumen function was prioritized over maintenance of blood P. These results shed light on mechanisms of control of P homeostasis in the face of short term P deficiency.

Acknowledgements

Funding for this work provided, in part, by the Virginia Agricultural Experiment Station and the Hatch Program of the National Institute of Food and Agriculture, U.S. Department of Agriculture. Author Xin Feng received fellowship support from the John Lee Pratt Foundation.

References

- Ahvenjarvi, S., A. Vanhatalo, P. Huhtanen, and T. Varvikko. 2000. Determination of reticulo-rumen and whole stomach digestion in lactating cows by omasal canal or duodenal sampling. *Br. J. Nutr.* 83:67-77.
- AOAC. 1984. Official methods of analysis. 14th ed. Association of official analytical chemists. Arlington, VA.
- Bravo, D., C. Bogaert, F. Meschy, and D. Sauvant. 2003a. Plasma phosphorus content and dietary phosphorus availability in adult sheep. *Anim. Res.* 52:427-435.
- Bravo, D., D. Sauvant, C. Bogaert, and F. Meschy. 2003b. Quantitative aspects of phosphorus excretion in ruminants. *Reprod. Nutr. Dev.* 43:285-300.
- Breves, G., R. Ross, and H. Holler. 1985. Dietary phosphorus depletion in sheep: Effects on plasma inorganic phosphorus, calcium, 1,25-(oh)₂-vit-d₃ and alkaline phosphatase and on gastrointestinal p and ca balances. *J. Agric. Sci.* 105:623-629.
- Breves, G. and B. Schroder. 1991. Comparative aspects of gastrointestinal phosphorus metabolism. *Nutr. Res. Rev.* 4:125-140.
- Care, A. D. 1994. The absorption of phosphate from the digestive tract of ruminant animals. *Br. Vet. J.* 150:197-205.
- Care, A. D., J. P. Barlet, and H. M. Abdel-Hafeez. 1980. Calcium and phosphorus homeostasis in ruminants and its relationship to the etiology and prevention of parturient paresis. Pages 429-446 in *Proc. 5th International Symposium on Ruminant Physiology*. eds Y. Ruckebusch & P. Thivend. Lancaster: MTP Press.

Chicco, C. F., C. B. Ammerman, J. E. Moore, W. Von, L. R. Arrington, and R. L. Shirley. 1965. Utilization of inorganic ortho-, meta- and pyrophosphates by lambs and by cellulolytic rumen microorganisms in vitro. *J. Anim. Sci.* 24:355-363.

Erickson, G. E., T. J. Klopfenstein, C. T. Milton, D. Brink, M. W. Orth, and K. M. Whittet. 2002. Phosphorus requirement of finishing feedlot calves. *J. Anim. Sci.* 80:1690-1695.

Erickson, G. E., T. J. Klopfenstein, C. T. Milton, D. Hanson, and C. Calkins. 1999. Effect of dietary phosphorus on finishing steer performance, bone status, and carcass maturity. *J. Anim. Sci.* 77:2832-2836.

Field, A. C., J. Kamphues, and J. A. Woolliams. 1983. The effect of dietary intake of calcium and phosphorus on the absorption and excretion of phosphorus in chimaera-derived sheep. *J. Agric. Sci.* 101:597-602.

France, J. and R. C. Siddons. 1986. Determination of digesta flow by continuous marker infusion. *J. Theo. Biol.* 121:105-119.

Gartner, R. J. W. 1982. Effect of induced, subclinical phosphorus deficiency on feed intake and growth of beef heifers. *J. Agric. Sci.* 98:23-29.

Geisert, B. G., G. E. Erickson, T. J. Klopfenstein, C. N. Macken, M. K. Luebbe, and J. C. MacDonald. 2010. Phosphorus requirement and excretion of finishing beef cattle fed different concentrations of phosphorus. *J. Anim. Sci.* 88:2393-2402.

Guyton, A. D., J. M. McKinney, and K. F. Knowlton. 2003. The effect of steam-flaked or dry ground corn and supplemental phytic acid on phosphorus partitioning and ruminal phytase activity in lactating cows. *J. Dairy Sci.* 86:3972-3982.

- Harvatine, D. I., J. E. Winkler, M. Devant-Guille, J. L. Firkins, N. R. St-Pierre, B. S. Oldick, and M. L. Eastridge. 2002. Whole linted cottonseed as a forage substitute: Fiber effectiveness and digestion kinetics. *J. Dairy Sci.* 85:1988-1999.
- Holler, H., A. Figge, J. Richter, and G. Breves. 1988. Calcium and inorganic phosphate net absorption from the sheep colon and rectum perfused in vivo. *J. Anim. Phys. Anim. Nutr.* 59:9-15.
- Jackson, J. A., D. L. Langer, and R. W. Hemken. 1988. Evaluation of content and source of phosphorus fed to dairy calves. *J. Dairy Sci.* 71:2187-2192.
- Knowlton, K. F. and J. H. Herbein. 2002. Phosphorus partitioning during early lactation in dairy cows fed diets varying in phosphorus content. *J. Dairy Sci.* 85:1227-1236.
- Komisarczuk, S., R. J. Merry, and A. B. McAllan. 1987. Effect of different levels of phosphorus on rumen microbial fermentation and synthesis determined using a continuous culture technique. *Br. J. Nutr.* 57:279-290.
- NRC. 1996. Nutrient requirements of beef cattle. 7th rev. ed. Natl. Acad. Press, Washington, DC.
- NRC. 2001. Nutrient requirements of dairy cattle. 7th rev. ed. Natl. Acad. Press, Washington, DC.
- Puggaard, L., N. B. Kristensen, and J. Sehested. 2011. Effect of decreasing dietary phosphorus supply on net recycling of inorganic phosphate in lactating dairy cows. *J. Dairy Sci.* 94:1420-1429.
- Ray, P. P., J. Jarrett, and K. F. Knowlton. 2013. Effect of dietary phytate on phosphorus digestibility in dairy cows. *J. Dairy Sci.* 96:1156-1163.

Sabbagh, Y., S. P. O'Brien, W. P. Song, J. H. Boulanger, A. Stockmann, C. Arbeeny, and S. C. Schiavi. 2009. Intestinal npt2b plays a major role in phosphate absorption and homeostasis. *J. Am. Soc. Nephrol.* 20:2348-2358.

SAS Institute. 2008. *Sas/stat*[®] 9.2 user's guide. Cary, NC: SAS Institute Inc.

Scharrer, E. 1985. Phosphate absorption at different intestinal sites in the developing lamb. *Q. J. Exp. Physiol Cogn. Med. Sci.* 70:615-621.

Scott, D. and W. Buchan. 1987. The effects of feeding either hay or grass diets on salivary phosphorus secretion, net intestinal phosphorus absorption and on the partition of phosphorus excretion between urine and feces in the sheep. *Q. J. Exp. Physiol.* 72:331-338.

Scott, D., A. F. McLean, and W. Buchan. 1984. The effect of variation in phosphorus intake on net intestinal phosphorus absorption, salivary phosphorus secretion and pathway of excretion in sheep fed roughage diets. *Q. J. Exp. Physiol.* 69:439-452.

Scott, D., F. G. Whitelaw, W. Buchan, and L. A. Bruce. 1985. The effect of variation in phosphorus intake on salivary phosphorus secretion, net intestinal phosphorus absorption and faecal endogenous phosphorus excretion in sheep. *J. Agric. Sci.* 105:

Ternouth, J. H. 1990. Phosphorus and beef production in northern australia .3. Phosphorus in cattle - a review. *Trop. Grasslands* 24:159-169.

Ternouth, J. H., H. M. S. Davies, J. T. B. Milton, M. W. Simpsonmorgan, and N. E. Sands. 1985. Phosphorus-metabolism in ruminants.1. Techniques for phosphorus depletion. *Aust. J. Agric. Res.* 36:637-645.

Tolleson, D. R. and L. L. Erlinger. 1989. An improved harness for securing fecal collection bags to grazing cattle. *J. Range Manage.* 42:396-399.

- Uden, P., P. E. Colucci, and P. J. Vansoest. 1980. Investigation of chromium, cerium and cobalt as markers in digesta - rate of passage studies. *J. Sci. Food Agr.* 31:625-632.
- Van Soest, P. J., J. B. Robertson, and B. A. Lewis. 1991. Methods for dietary fiber, neutral detergent fiber, and nonstarch polysaccharides in relation to animal nutrition. *J. Dairy Sci.* 74:3583-3597.
- Wasserman, R. H. and A. N. Taylor. 1976. Gastrointestinal absorption of calcium and phosphate. . *Handbook of physiology. Sec 7: Endocrinology. Vol. Vii, parathyroid gland.* Washington, D. C. Am. Physiol. Soc.
- Wise, M. B., S. E. Smith, and L. L. Barns. 1958. The phosphorus requirements of calves. *J. Anim. Sci.* 17:89-99.
- Witt, K. E. and F. N. Owens. 1983. Phosphorus: Ruminant availability and effects on digestion. *J. Anim. Sci.* 56:930-937.
- Wu, Z., L. D. Satter, A. J. Blohowiak, R. H. Stauffacher, and J. H. Wilson. 2001. Milk production, estimated phosphorus excretion, and bone characteristics of dairy cows fed different amounts of phosphorus for two or three years. *J. Dairy Sci.* 84:1738-1748.
- Wu, Z., L. D. Satter, and R. Sojo. 2000. Milk production, reproductive performance, and fecal excretion of phosphorus by dairy cows fed three amounts of phosphorus. *J. Dairy Sci.* 83:1028-1041.
- Wu, Z., S. K. Tallam, V. A. Ishler, and D. D. Archibald. 2003. Utilization of phosphorus in lactating cows fed varying amounts of phosphorus and forage. *J. Dairy Sci.* 86:3300-3308.

Table 4-1 Ingredient and nutrient composition of diet

Item	Diet (P, % of DM)			
	0.15	0.27	0.36	0.45
Ingredient, % of DM				
Beet pulp dehydrated	40.83	40.72	40.6	40.5
Corn silage	30.91	30.83	30.72	30.65
Corn	15.95	15.91	15.86	15.82
Molasses dehydrated	4.99	4.97	4.96	4.95
Megalac ¹	4.99	4.97	4.96	4.95
Urea	1.88	1.71	1.68	1.58
Vitamin ADE ²	0.25	0.25	0.25	0.25
Trace mineral salt ³	0.2	0.2	0.2	0.2
Monoammounium Phosphate	0	0.44	0.77	1.1
Nutrient, % of DM				
DM	60.7	60.7	60.7	60.7
CP	12.6	12.6	12.6	12.6
NDF	32.1	32.1	32.1	32.1
ADF	18.2	18.2	18.2	18.2
P	0.15	0.27	0.36	0.45

1 Church & Dwight Co, Princeton, NJ.

2 Contained 26,400 KIU vitamin A; 8,800 KIU vitamin D; and 44,000 IU vitamin E per kg of DM.

3 Contained 37% Na, 60% Cl, 0.03% K, 0.3% Mg, 14% S.

Table 4-2 Effect of dietary P content on DM intake and digestibility

Item	P, % of DM				SE	<i>P</i> -value ¹		
	0.15	0.27	0.36	0.45		Trt	Linear	Quad
DMI, kg/d	4.86	5.17	4.51	5.05	0.27	0.25	0.95	0.77
NDF intake, kg/d	1.56	1.66	1.45	1.62	0.87	0.25	0.94	0.77
Nitrogen intake, g/d	97.8	103.7	98.4	101.7	5.48	0.25	0.95	0.77
DM digestibility, %	77.0	76.7	81.3	77.5	1.57	0.07	0.28	0.30

¹ *P*-values for treatment, linear and quadratic effects.

Table 4-3 Effect of dietary P content on intake and absorption of total P and inorganic P (Pi)

Item	P, % of DM				SE	P-value ¹		
	0.15	0.27	0.36	0.45		Trt	Linear	Quad
Total P								
Intake, g/d	7.14	13.8	16.4	22.7	0.94	<0.0001	<0.0001	0.56
Duodenal flow, g/d	13.4	18.5	22.9	27.4	1.53	<0.0001	<0.0001	0.69
Ileal flow, g/d	6.80	7.87	8.42	10.4	1.00	0.12	0.03	0.56
Absorption from SI ² , g/d	6.96	11.1	14.6	17.2	1.66	0.001	0.0002	0.90
Absorption from SI, % duodenal flow	50.7	58.4	62.8	62.0	4.86	0.21	0.07	0.44
Absorption from LI ³ , g/d	0.84	1.06	1.88	1.06	0.49	0.49	0.46	0.38
Fecal excretion, g/d	5.76	6.60	6.63	9.19	0.97	0.09	0.03	0.29
Total P digestibility, %	21.9	51.4	57.5	59.5	3.34	0.0002	<0.0001	0.007
Pi								
Intake, g/d	5.45	8.64	11.6	16.4	0.65	<0.0001	<0.0001	0.04
Duodenal Pi flow, g/d	6.41	12.2	15.7	20.3	1.43	<0.0001	<0.0001	0.93
Ileal Pi flow, g/d	2.79	3.66	5.06	7.38	0.85	0.01	0.002	0.27
Absorption of Pi from SI, g/d	4.06	9.11	10.6	13.1	1.56	0.002	0.0004	0.47

Absorption of Pi from LI, g/d	-1.1	-0.51	1.09	0.98	0.49	0.02	0.005	0.73
Fecal Pi excretion, g/d	3.9	4.12	4.34	6.43	0.81	0.16	0.06	0.24
Salivary P ⁴ , g/d	6.31	5.00	6.62	5.21	1.39	0.60	0.69	0.96
Serum P, mg/dL	4.36	6.31	7.68	8.5	0.53	0.002	0.0002	0.53
Urine P, mg/dL	2.77	5.55	8.03	15.2	4.46	0.24	0.06	0.52

¹ *P*-values for treatment, linear and quadratic effects.

² SI = small intestine.

³ LI = large intestine.

⁴ Calculated as the difference between duodenal P flow and dietary P intake.

Chapter 5 PARAMETERIZATION OF A RUMINANT MODEL OF P DIGESTION AND METABOLISM

X. Feng, K. F. Knowlton, and M. D. Hanigan. 2015. Parameterization of a ruminant model of phosphorus and metabolism. *J. Dairy Sci.* (Accepted)

* Used by permission of the Journal of Dairy Scienc

Abstract

The objective of the current work was to parameterize the digestive elements of the model of Hill et al. (2008) using data collected from animals that were ruminally, duodenally, and ileally cannulated, thereby providing a better understanding of the digestion and metabolism of phosphorus (**P**) fractions in growing and lactating cattle. The model of Hill et al. (2008) was fitted and evaluated for adequacy using the data from six animal studies (Feng et al., 2011, Ray et al., 2012b, Feng et al., 2013, Ray et al., 2013, Jarrett et al., 2014, Feng et al., 2015). It was hypothesized that sufficient data would be available to estimate P digestion and metabolism parameters and that these parameters would be sufficient to derive P bio-availabilities of a range of feed ingredients. Inputs to the model were DM intake; total feed P concentration (f_{PFD}); phytate (**Pp**), organic (**Po**) and inorganic (**Pi**)P as fractions of total P (f_{PpPt} , f_{PoPt} , f_{PiPt}); microbial growth; amount of Pi and Pp infused into the omasum or ileum; milk yield; and BW. The available data were sufficient to derive all model parameters of interest. The final model predicted that given 75 g/d total P input, the total tract digestibility of P was 40.8%, Pp digestibility in the rumen was 92.4% and in the total tract was 94.7%. Blood P recycling to the rumen was a major source of Pi flow into the SI, and the primary route of excretion. A large proportion of Pi flowing to the small intestine (**SI**) was absorbed, however additional Pi was absorbed from the large intestine (3.15%). Absorption of Pi from the SI was regulated, and given the large flux of salivary P recycling, the effective fractional SI absorption of available P derived from the diet was 41.6% at requirements. Milk synthesis used 16% of total absorbed P, and less than 1% was excreted in urine. The resulting model could be used to derive P bio-availabilities of commonly used feedstuffs in cattle production.

Key Words: model, phosphorus, digestion and absorption, dairy cow

Introduction

Eutrophication caused by excessive phosphorus (**P**) and nitrogen (**N**), released into aquatic systems impairs growth and survival of aquatic species (Smith et al., 1999). Continuous land application of animal manure based on crop N demand has resulted in a buildup of P because the N to P ratio in manure typically does not match crop requirements (Ellis and Tillman, 1961). Excessive P often runs off into surface water aggravating eutrophication. Practices which reduce P excretion will yield manure that more precisely meets crop needs, thus reducing the risk of P loss. Numerous studies reported that fecal P excretion is positively correlated with dietary P intake in dairy and beef cattle (Wu et al., 2000, Knowlton and Herbein, 2002, Geisert et al., 2010). Precisely matching dietary P to animal requirements is essential if excretion is to be minimized. Based on a national survey (Harrison et al., 2012), 99% of responding nutritionists feed less P now than they did 5 years earlier. However, uncertainty regarding feed P availability is a barrier to further decreases. Current ruminant feeding standards assume homogenous P absorption from feeds within a few broad feed categories. However, previous studies have shown that grain processing (Duskova et al., 2001, Hill et al., 2002), grain type (Bravo et al., 2002, Guyton et al., 2003b), and exogenous enzymes (Knowlton et al., 2007) affect P digestion. Improved understanding of P absorption and recycling is essential to further refine P feeding recommendations.

Extant P models considering total P have focused on interpreting tracer kinetic data on small ruminant P digestion and metabolism (Vitti et al., 2000, Dias et al., 2006, Dias et al., 2011). In grain-based diets 65 to 70% of P is organically bound in phytate (Morse et al., 1992) which is unavailable for non-ruminant animals as they do not express phytase which catalyzes the release of phosphate from phytate. However, ruminal microbes synthesize phytase thus

making phytate P at least partially available to ruminants (Liao et al., 2005). The National Research Council (NRC, 2001) predicts constant P absorption for forages (64%) and concentrates (70%), suggesting that phytate P from grains is as available as the organic and inorganic P in forages. Ruminal P availability is greatly influenced by feed type and processing method (Kincaid and Rodehutsord, 2005) as well as P form. Thus fixed absorption coefficients may misrepresent dietary P supply.

The model of Hill et al. (2008) fractions P into 3 pools: inorganic P (Pi), phytate P (Pp), and non-phytate, organic P (Po). This structure can accommodate differences in digestibility of the different P forms. As a result, the model can provide an improved understanding of P digestion and metabolism. The model also simulates degradation of P in the small (SI) and large intestines (LI) separately thus accommodating different digestion and absorption mechanisms employed at these sites. When the model was constructed, insufficient data were available to derive all necessary parameters. Since this time, our group has conducted several experiments (Feng et al., 2011, Ray et al., 2012b, Feng et al., 2013, Ray et al., 2013, Jarrett et al., 2014, Feng et al., 2015) which should provide the data required for parameterization of the digestive elements. It was hypothesized that sufficient data were available to parameterize the digestion and metabolism coefficients within the model, and the behavior simulated from the resultant model could be used to derive P bio-availabilities for various feed ingredients. The objective of the current model work was to fully parameterize the Hill et al. (2008) model using data collected from animals that were ruminally, duodenally, and ileally cannulated, thereby providing a better understanding of the digestion and metabolism of P in growing and lactating cattle

Materials and Methods

Overview

The model consisted of a dynamic system of differential equations coded in Advanced Continuous Simulation Language (acsIX, ver. 3.0.2.1, Aegis Technologies Group, Huntsville, AL). Briefly, P was represented in P_p, P_o and P_i forms within the digestive tract, with P_i absorbed into a blood pool and partitioned into bone, milk, soft tissue (if animals are growing) and urine. A detailed description of the model is provided in Hill et al. (2008), and a schematic is presented in Figure 1.

For model development purposes, a reference state was defined as a cow weighing 600 kg, with a blood volume of 120 kg (20% of BW including extracellular space body fluid, (Ternouth, 1968), producing 30 kg of milk/d, consuming 23 kg of DM/d with 0.33% P (P_p 40%, P_o 30.67% and P_i 29.33%), having a ruminal passage rate of 3.15/d (13.1%/h), an apparent affinity constant 0.033 g/L for blood P and blood P concentration of 0.0557 g/L. The dietary P concentration was chosen to just meet but not exceed NRC requirements for that level of production. Incorporation of P_i into tissue gain was assumed to be 10 g/d if BW was less than mature BW which was set to 500 kg in the current model.

Model Changes

Changes were made to the overall model structure to better accommodate the data available for parameter derivation. A flux was added to accommodate intestinal infusions and a soft tissue P retention flux was added to better represent P data from growing animals. These changes are described in detail in the following sections. Throughout this description, the abbreviations used followed the pattern adopted by Hill et al. (2008) and are listed in Table 1: Z_A, B where A was a substrate or pool and B is a product. Z represented C (concentration, g/L), F (flux, g/d), K (mass action rate constant, /d), k (apparent affinity constant, g/L), R (rate constant,

g/d), f (fractional rate or proportioning constant, g/g), x (sensitivity exponent, unitless), or Q (mass or quantity, g). The three forms of P (Pp, Po and Pi) were represented in the rumen (**RUM**), SI and LI. Blood (**Bld**) and bone Pi were also represented. The differential equations which were altered relative to Hill et al. (2008) are as follows.

The Rumen Degradation of Pp in the rumen ($F_{PpRum, DegRum}$) was altered to be a mass action function of ruminal Pp (Q_{PpRum}) referenced to the initial pool size of Pp in the rumen (iQ_{PpRum}):

$$F_{PpRum, DegRum} = \left(\frac{Q_{PpRum}}{iQ_{PpRum}} \right)^{x_{RPpRum, PiRum}} \times R_{PpRum, PiRum} \quad [1]$$

This allowed application of an exponent ($x_{RPpRum, PiRum}$) to the ratio to adjust sensitivity to changes in the ratio. Although not a functional change, the independent fluxes describing conversion of Pp to Po and Pi were combined into a single overall flux describing the action of phytase, , and the fractional production of Po and Pi determined algebraically from the phytase driven flux.

Phytate, Po, and Pi escape from the rumen, previously represented as a function of a static fluid flow (198 L/d), were represented as functions of a specified passage rate ($K_{Passage}$; $3.15/d = 13.1\%/h$):

$$F_{PpRum, PpSI} = Q_{PpRum} \times K_{Passage} \quad [2]$$

$$F_{PoRum, PoSI} = Q_{PoRum} \times K_{Passage} \quad [3]$$

$$F_{PiRum, PiSI} = Q_{PiRum} \times K_{Passage} \quad [4]$$

Available data suggested that the flow of Pi into the rumen due to recycling in saliva ($F_{PiBld, PiRum}$) was more appropriately described by Michaelis-Menten kinetics:

$$F_{PiBld, PiRum} = \frac{V_{PiSal} \times DMI /_{ref} DMI \times C_{PiBld}}{\kappa_{PiBld, PiRum} + C_{PiBld}} \quad [5]$$

Where V_{PiSal} (g/d), and $k_{PiBld, PiRum}$ (g/L) represented the maximum velocity for salivary P secretion and the apparent affinity constant for blood P, respectively.

Phosphorus is required for ruminal microbial growth (MiG), and the P content of microbes (f_{PiPm}) was set to 1.61 g P/100 g microbial DM (Ray et al., 2013) assuming microbial needs were driven solely by growth rates:

$$F_{PiRum, PmRum} = MiG \times f_{PiPm} \quad [6]$$

Where MiG (g/d) was a specified input to the model.

The Lower Tract Absorption and flow of P from the SI was revised to represent potential Pp degradation in the abomasum after omasal sampling:

$$F_{PoSI, PiSI} = (F_{PoRum, PoSI} + F_{PpSI, PoSI}) \times f_{PoSI, PiSI} \quad [7]$$

The absorption of Pi from SI was calculated as described in Hill et al. (2008) except that Pi from degradation of Po in SI ($F_{PoSI, PiSI}$) and Pi infused into omasum ($F_{PiOmalInf}$) were added to accommodate the Feng et al. (2011) study.

$$F_{PiSI, PiBld} = (F_{PiRum, PiSI} + F_{PoSI, PiSI} + F_{PiOmalInf} + F_{PpSI, PiSI}) \times f_{PiSI, PiBld} \times \left(\frac{iQ_{PiBld}}{Q_{PiBld}} \right)^{x_{PiSI, PiBld}} \quad [8]$$

The exponent ($x_{PiSI, PiBld}$) was included in equation [8] to allow the magnitude of the feedback effect of blood P on absorption to be derived from observed data where a value of 0 resulted in no feedback and values greater than 0 in feedback inhibition.

Flow of Pp, Po and Pi to LI were revised to accommodate Pp and Po degradation in SI:

$$F_{PpSI, PpLI} = F_{PpRum, PpSI} - F_{PpRum, PpSI} \times f_{PpSI, DegSI} \quad [9]$$

$$F_{PoSI, PoLI} = F_{PoRum, PoSI} + F_{PpSI, PoSI} - F_{PoSI, PiSI} \quad [10]$$

$$F_{PiSI, PiLI} = F_{PiRum, PiSI} + F_{PoSI, PiSI} + F_{PiOmalInf} - F_{PiSI, PiBld} \quad [11]$$

Infused Pp into ileum ($F_{PpIleInf}$) was included in the representation of Pp degradation in LI, and a unique degradation constant was applied as infused Pp and Pp flowing from the SI were observed to have different degradation rates:

$$F_{PpLI, DegLI} = F_{PpSI, PpLI} \times f_{PpLI, DegLI} + F_{PpIleInf} \times f_{PpInf, DegLI} \quad [12]$$

Fluxes within the LI were assumed to follow the same degradation path for Pp as described in the rumen, and included the degradation of infused Pp to Po ($F_{PpIleInf}$, infused Pp solution also contained Po and Pi):

$$F_{PpLI, PiLI} = F_{PpLI, DegLI} \times f_{PpRum, PiRum} \quad [13]$$

$$F_{PpLI, PoLI} = F_{PpLI, DegLI} \times (1 - f_{PpRum, PiRum}) \quad [14]$$

$$F_{PoLI, PiLI} = (F_{PoSI, PoLI} + F_{PpLI, PoLI} + F_{PoIleInf}) \times f_{PoLI, PiLI} \quad [15]$$

Similar to ruminal microbial P calculations, the flux of Pi to Pm in the LI ($F_{PiLI, PmLI}$) was driven by microbial growth ($MiGLI$) assuming microbial growth in the LI was 10% of ruminal growth rates. This growth rate was selected to approximate the proportion of total tract fermentation occurring in the LI (Verbic et al., 1990):

$$F_{PiLI, PmLI} = MiGLI \times f_{PiPm} \quad [16]$$

Absorption of Pi from the LI ($F_{PiLI, PiBld}$) has been observed (Ray et al., 2013, Feng et al., 2015) and was represented as:

$$F_{PiLI, PiBld} = (F_{PpLI, PiLI} + F_{PoLI, PiLI} + F_{PiSI, PiLI} + F_{PiIleInf} - F_{PiLI, PmLI}) \times f_{PiLI, PiBld} \quad [17]$$

Fecal output of Pp, Po and Pi were calculated as below with the infused P from the ileum being added to the equations:

$$F_{PpLI, PpFe} = F_{PpSI, PpLI} + F_{PpIleInf} - F_{Pp, DegLI} \quad [18]$$

$$F_{PoLI, PoFe} = F_{PoSI, PoLI} + F_{PpLI, PoLI} + F_{PiLI, PmLI} + F_{PoIleInf} - F_{PoLI, PiLI} \quad [19]$$

$$F_{PiLI, PiFe} = F_{PiSI, PiLI} + F_{PoLI, PiLI} + F_{PpLI, PiLI} + F_{PiIleInf} - F_{PiLI, PmLI} - F_{PiLI, PiBld} \quad [20]$$

Blood Phosphorus The flux of Pi absorbed from the LI ($F_{PiLI, PiBld}$) was added to the differential equation for Pi in blood:

$$\begin{aligned} \frac{dQ_{PiBld}}{dt} = & F_{PiBone, PiBld} + F_{PiSI, PiBld} + F_{PiLI, PiBld} - F_{PiBld, PiBone} \\ & - F_{PiBld, PiMlk} - F_{PiBld, PiRum} - F_{PiBld, PiUrn} \end{aligned} \quad [21]$$

A body size scalar was added to the equation representing removal of Pi from blood to urine thus accommodating animals of varying body size:

$$F_{PiBld, PiUrn} = \left(\frac{Q_{PiBld}}{iQ_{PiBld}} \right)^{x_{PiBld}} \times R_{PiBld, PiUrn} \times \frac{BW}{refBW} \quad [22]$$

Bone Phosphorus A new flux representing P use for growth (F_{PiGain}) was added to the differential equation for bone P to reflect use for growth in young animals. If body weight is less than mature bodyweight (set as 500 kg in this model), F_{PiGain} is equal to R_{PiGain} where R_{PiGain} is the P retention rate in gain (g/d), otherwise F_{PiGain} was 0. A scalar for body size was included in calculating the flux of Pi between blood and bone:

$$\frac{dQ_{PiBone}}{dt} = F_{PiBld, PiBone} + F_{PiGain} - F_{PiBone, PiBld} \quad [23]$$

$$F_{PiBld, PiBone} = Q_{PiBld} \times K_{PiBld, PiBone} \times \frac{BW}{refBW} \quad [24]$$

$$F_{PiBone, PiBld} = Q_{PiBone} \times K_{PiBone, PiBld} \times \frac{BW}{refBW} \quad [25]$$

Balance of total P in the body was represented as the difference between total input and output thereby allowing comparison to P balance calculated for animal observations:

$$\begin{aligned} PBalance = & F_{PtFd, PtRum} + F_{PiOmalInf} + F_{PpIleInf} + F_{PolleInf} + F_{PilleInf} - F_{PtLI, PtFe} - F_{PiBld, PiUrn} - \\ & F_{PiBld, PiMlk} \end{aligned} \quad [26]$$

Experimental Data Description

The model was fitted to data from 6 experiments from our laboratory which will be denoted using the author initials: LK1(Feng et al., 2011),XF2 (Feng et al., 2013), XF3(Feng et al., 2015), PR1(Ray et al., 2012b), PR2 (Ray et al., 2013) and JJ1(Jarrett et al., 2014). The data are summarized in Table 3. Inputs to the model were DM intake; proportion of total P in feed (f_{PiFd}); Pp, Po and Pi as proportions of total P (f_{PpPt} , f_{PoPt} , f_{PiPt}); microbial growth; amount of Pi, Po, and Pp infused into omasum or ileum; milk yield; and BW (Table 2). Milk yield, BW, total P intake and proportion of Pp and Pi in feed were measured. Organic P was obtained by subtracting Pp and Pi from total P. Ruminal microbial growth was calculated using the equation from Firkins et al. (1998).

Except study LK1, the procedures used to collect the data and the experimental treatments were described in the primary paper. In the LK1 study, four ruminally- and ileally-cannulated crossbred cows were used in a 4×4 Latin Square with 21 d periods. Cows were fed a total mixed ration containing 0.21% P, providing 50% of their estimated P requirement. On d 13 to 21 of each period, each cow was infused daily with 0, 20.1, 40.2, or 60.3 g Pi into the abomasum. Ileal samples were collected every 9 h and total fecal collection was conducted from d 18 to 21. Blood samples were obtained on d 20 and 21 of each period from coccygeal vessel.

Parameter Estimation and Model Evaluation

Parameter estimates were derived from the above data using aclsX and a least squares optimization algorithm (NL2SOL; Powell, 1970) which used an approximation of the Hessian matrix to search the parameter space based on gradient information. Parameters fitted included those describing P degradation and metabolism in the rumen ($R_{PpRum, PiRum}$, $K_{PoRum, PiRum}$, V_{PiSal}), small intestine (f_{PiSi} , $PiBld$), large intestine ($f_{PpLi, DegLi}$, $f_{PoLi, PiLi}$, f_{PiLi} , $PiBld$), growth (R_{PiGain}), P flow

from blood to bone and urine ($K_{PiBld, PiBone}$, $R_{PiBld, PiUrn}$). Initial fits included parameter estimates for Pp and Po degradation in the SI ($f_{PpSI, DegSI}$, $f_{PoSI, DegSI}$), but these were found to be essentially 0 and thus were fixed to values of 0 and removed from the parameter estimation list. The exponents controlling Pp degradation in the rumen (eqn. [1]) and Pi absorption from the SI (eqn. [8]) were not uniquely identifiable from the data, but range testing indicated they should be set to values of approximately 2.0 and 2.5, respectively, and thus these values were adopted for the final parameter estimations and all subsequent work. Therefore, a total of 10 parameters were fitted to the data (Table 4).

Standard deviations (**STD**) of the estimates were derived using a bootstrap approach (Hill et al., 2008) assuming that residual errors reflected variance in the observed data. Residual errors were randomly sampled and each sample was applied to a random observed value of each variable. This resampling was repeated once for each available observation. When the complete set of observations was resampled, the parameters were optimized again. This procedure was repeated 700 times and the resulting population of parameter estimates was used to determine the STD of estimates.

Overall variance of the predictions was determined by calculation of the mean square prediction error (**MSPE**) as described by Bidy and Toutenberg (1977):

$$MSPE = \frac{1}{n} \sum_{i=1}^n (O_i - P_i)^2$$

where n represents the total number of observations, O_i the observed value and P_i the predicted value. It was decomposed into error due to random variation, deviation of the regression slope from unity (slope bias) and to central bias (mean bias). Root mean square

prediction errors (**RMSPE**) were obtained by taking the square root of the MSPE. It was expressed as a proportion of the observed mean as an estimate of the overall prediction error.

Global sensitivity analyses were conducted as previously described (Saltelli et al., 1999) to determine the sensitivity of P fluxes in different compartments to total P intake, proportions of P_p, P_o, and P_i in the diet, and the 10 parameter estimates. An interference factor of 4 and 4 resamplings was used. Analyses were performed using the FAST algorithm with the default frequency step. The minimum and maximum range of P intake and proportions of dietary P_p, P_o and P_i were set equal to the range of the observed data. The minimum and maximum range of the ten parameter estimates were set to 80% and 120% of the parameter estimates, respectively.

Results and Discussion

The standard deviation of parameter estimates derived from fitting the model to the observed data were low (<21% of the parameter estimate) indicating the data were adequate to define the model with a high degree of confidence. Root mean squared prediction errors ranged from 22.6% of the observed mean for ruminal Pt pool size up to 265% for P balance. However, in the latter case, the observed mean was 3.16 g/d with an RMSPE of 8.15 g/d as compared to a mean Pt intake of 54 g/d. Thus the error was not particularly large in magnitude even though it was proportionally so. Of the fluxes, the largest absolute error was for Pt flow from the rumen at 38.7 g/d. However, that flow was also the largest flux averaging 119 g/d. When prediction errors were expressed as a proportion of total P intake, most were less than 15% of P intake. Blood concentrations were predicted with a 24% error with approximately 35% of that error almost evenly split between mean and slope bias. Given the errors inherent in making many of the measurements (20% or greater), the RMSPE values indicate relatively good agreement with the

observed biology. The lack of significant mean or slope bias in the predictions also supports this assertion (Table 5 and Figures 2, 3).

The Rumen

The revised model was compared to the original model by setting model inputs to the reference input values used in the prior work. Given intakes of 30, 23, and 22 g/d of Pp, Po and Pi the model predicted 2.3, 13.3, and 215.7 g/d of Pp, Po and Pi flow to the SI, respectively (Figure 1). More Pp was degraded in the rumen in the revised model (27.7 vs. 23 g/d in revised vs original model). Approximately 63 g/d of Po was converted to Pi in the revised model whereas no ruminal Po degradation was assumed in the original model. Predicted microbial P outflow was also higher compared to the original model (30 g/d vs. 14 g/d) and was higher than the expected synthesis rate of 12 g/d based on average microbial content (Durand and Kawashima, 1980).

Digestibility of Pp in the rumen was 92%, which was much greater than that for the original model (74%). Phytase sequentially hydrolyzes phytate (inositol phosphate with 6 phosphate molecules; IP6) to lower inositol phosphates (IP5, IP4, IP3, and IP2) plus phosphoric acid and eventually inositol (Anderson, 1915). Park et al. (2002b) suggested the rate of production of IP3 from highly phosphorylated IPs (IP6, IP5, IP4) exceeded the rate of degradation of IP3 in the forestomach indicating that ruminal phytase preferentially degrades highly phosphorylated inositols. The model represented the lower order IP (IP5 through IP2) in aggregate within the Po pool, thus conclusions regarding differential rates of degradation of the various IP are restricted to IP6 (Pp) vs lower IP plus other organic forms (Po). The rate constant for degradation of IP6 ($R_{PpRum, PiRum}$) was 67.5 g/d whereas the rate of degradation of Po ($K_{PoRum, PiRum}$) was 14.9 /d. The reduced rate of Po degradation vs Pp degradation is consistent

with the observations of Park et al. (2002b) and suggests the rate limiting step in phytate degradation is not cleavage of the first Pi. This is also consistent with the relatively larger Po pool in the rumen as compared to the Pp pool. For the reference status cow, the turnover rate of the Pp pool is 158.8%/h whereas the turnover rate of the Po pool is 61.9%/h given pool sizes for Pp and Po of 0.72 g and 4.23 g, respectively.

The total P flow to the SI was almost three fold the total dietary P input to the rumen due to a large salivary P flux as noted previously by Ray et al. (2013) and Jarrett et al. (2014). As not all of the secreted P is reabsorbed in the SI, this flux serves as the major route of disposal. It also may have evolved to ensure adequate Pi availability for the microbes in the rumen (Puggaard et al., 2011).

Small intestine and large intestine

In the revised model the parameter estimates for Pp and Po degradation in the SI ($f_{PpSI, DegSI}$, $f_{PoSI, DegSI}$) solved for values that were not significantly different from 0 in initial runs, and thus were fixed to 0 for subsequent fits to the data. It was not surprising that Pp degradation was 0, although the possibility of apparent degradation in the SI for omasally sampled animals existed due to the fact that phytase is most active at low pH in the abomasum after the omasal sample has been taken. The absence of any apparent degradation may reflect the extensive degradation in the rumen. Given the extremely high rate of degradation of Pp in the rumen, failure to go to completion may be a reflection of the presence of some resistant material. This would explain the apparent lack of phytase activity in the SI even in animals that were omasally sampled.

Approximately 83% of Po appearing in the rumen from feed, Pp degradation, and Pm synthesis was converted to Pi the rumen, and 42.8% of the 15.9 g/d appearing in the LI was

converted to Pi. Surprisingly Po digestion in the SI was negligible. The P present in plant and microbial phospholipids and nucleic acids should have been represented in the Po pool given the method of conducting the fractionation. Both molecules are known to be absorbed from the intestine (Blomstrand, 1955, Verbic et al., 1990) and thus one would expect some absorption across the SI. The lack of such an event may be due to inadequate enzymatic activity, or possibly Po remaining after the extensive degradation in the rumen was resistant to enzymatic attack. Another possibility is that there is secretion of Po (i.e. phospholipids from sloughed cells) into the intestine and the absorption of Po flowing from the rumen is offset by secretion of Po into the gut lumen.

Absorption of Pi from the SI averaged 84% of that flowing from the rumen which equates to 181 g/d for the reference diet (Figure 1). This is approximately 3 times Pt intake. However, due to the negative feedback effects of blood Pi on the rate of SI absorption (eqn. [8]), fractional extraction would be greater for low P diets and less for high P diets. Flow of P to the SI is dominated by P re-entry into the rumen as observed by Ray et al. (2013). Of the 181 g/d absorbed, 156 g/d are secreted back into the rumen. If one applies the fractional absorption rate of 84% to the recycled flux, 131 g of the secreted 156 g would be absorbed from the SI and the remaining 25 g would flow to the LI and to feces. This recycling to the rumen is an efficient method of helping to regulate P supply to the animal. It allows high P absorption to ensure adequate supply, and excretion of the excess back into the rumen to help prevent ruminal P deficiency. From an application standpoint, the apparent absorption is greatly reduced due to this large recycling flux. The flow of non-recycled, feed derived Pi from the rumen on the reference diet is 59.4 g/d and total Pi flow at the ileum is 34.7 g/d yielding an apparent Pi digestibility of 41.6% in the SI which is the effective absorption coefficient for the SI. Reduced dietary inputs

would reduce the rate of absorption based on mass action causing reduced ruminal recycling and thus an increase in the effective SI absorption coefficient, and the reverse for increased dietary inputs. Because the reference diet generates a P balance of very close to 0, the effective absorption rate is that which one would expect at the P requirement and thus can be used to generate bioavailability values for lactating cows.

Of the 2.3 g/d of Pp entering the LI, 0.7g/d was degraded. Ray et al. (2013) observed an average of 0.4 g/d of Pp degraded in the LI as a result of microbial activity. Contrary to the lack of Po degradation in the SI, more than 50% of Po entering the LI was degraded to Pi. The combination of Pi flow from the SI and Pp and Po degradation in the LI, results in a fairly substantial supply of Pi (42 g/d on the reference diet). Although a portion of the available Pi is assumed to be utilized by intestinal microbes (3 g/d) and 6 g/d is absorbed, 78% of it is excreted in feces. While absorption of Pi from the LI is a relatively new concept (Ray et al., 2013), its contribution to overall animal supply is minor compared to SI absorption which agrees with the prior body of work.

One of the objectives of the overall P project in our laboratory (experimental plus modeling) was to determine whether different P fractions had different digestibilities. The apparent total tract digestibilities of Pp, Po, and Pi based on dietary inputs were 95, 58, and -150%, respectively. The latter is a function of conversion of Pp and Po to Pi exceeding Pi absorption from the digestive tract. Clearly, unlike monogastrics, Pp degradation is quite extensive in the digestive tract and seems to offer little opportunity for improvement on average. However, the data used to define the model do not represent the full realm of diets and dietary management, and thus one cannot rule out the possibility that the extent of Pp degradation is considerably less under some conditions. Because Po and Pi arise within the system as a result of

Pp and Po degradation, it is more informative to look at apparent intestinal digestibilities which are 27 and 85%, respectively for Po and Pi. Thus there clearly are differences in digestibilities of the different fractions with apparent Po digestion being no more than 50% of supply whereas Pp digestion is extensive, and apparently not of great concern under the conditions of the studies used for parameterization. Finally apparent Pi absorption is quite extensive, however, the apparent absorption is much less due to a large recycling flux into the rumen, and SI absorption is regulated to resist deficiencies and excess (Figure 4 slope is 16.7%). The apparent total tract digestibility of Pt was predicted to be 40.8% which is in the range reported by Knowlton and Herbein (2002). One could use the fractional digestibility coefficients for Pp and Po and the effective absorption rate for Pi at neutral P balance to estimate P bio-availability for any ingredient provided knowledge of the proportions of Pp, Po, and Pi in the ingredient and the assumption that those digestibilities were constant across ingredients. These calculated bio-availabilities could be used directly in the current NRC to better reflect the true supply of P to the animal..

Blood and Bone P

Of the 187 g of Pi absorbed from the SI and LI, 156 g was recycled back to the rumen via saliva, 1 g/d was excreted in urine and 30 g/d was secreted in milk for the reference diet and animal (Figure 1). Recycled P represented 67.5% of the total P input to the rumen and was higher than the 45% recycling reported by Kebreab et al. (2005). As was observed from many studies, urinary Pi excretion represented a very small proportion of total P excretion in dairy cattle (Puggaard et al., 2011, Ray et al., 2013, Jarrett et al., 2014). Milk contained about 1 g of P per kg milk which was the same as reported by Feng et al. (2013).

Total P balance, calculated as the difference between total P inputs (diet, infused) and total P excreted in feces, urine, and milk was predicted to be -0.59 g/d for the reference diet with dietary P at NRC requirements of 0.33% of DM (Figure 1). This balance is lower than reported in Puggaard et al. (2011), but that study used a dietary P concentration of 0.45%. The error of prediction for P balance was observed to be 8.15 g/d (Table 5), and thus the predicted balance for the reference diet was clearly not significantly different from 0 indicating the diet was indeed balanced to P requirements as predicted by the NRC (2001) model.

Total P balance reflects bone P balance in the model given no representation of other storage sites. Balance is achievable at 50 kg milk/d with a dietary P content of 0.45% and DMI of 23 kg/d, and is fairly resistant to change decreasing approximately 0.17 g/d per kg milk yield increase with everything else held constant (Figure 4). Reducing dietary P concentration from 0.4% to 0.3%, a 23 g/d decrease in Pt supply, resulted in only a 2.7 g/d reduction in P balance (Figure 5). This underscores the extent of the regulation of Pi uptake in eqn. [8] and the impact of reduced secretion into the rumen. Increasing the proportion of phytate in the diet from 20% of total P to 50% resulted in a 0.5 g/d reduction in P balance regardless of the amount of P in the diet (Figure 6). Based on these observations, one must conclude that the amount of phytate in the diet is likely of little relevance to maintaining P balance in the animal for diets similar to those used in this work, although one cannot rule out a greater role for some ingredients or conditions.

Sensitivity Analysis

Results of global sensitivity analysis are presented in Table 6. In contrast to local sensitivity analysis in which the sensitivity coefficients represent the change in the response variable resulting from a unit change in a single driving variable, global analysis provide an assessment of the proportion of variation in an output explained by each driving variable given a

dataset containing a large population of simulations conducted with random changes in all the driving variables of interest. As can be seen from this table, most model predictions had the greatest sensitivity to the concentration of total P in the diet regardless of P composition with the exceptions of the pool size of Pp, the flow of Pp to the SI, the flow of Pp to the LI, and fecal excretion of Pp all of which were more responsive to the proportion of Pp in the diet.

Phosphorus balance was approximately equally responsive to dietary Pp and Pi. The enhanced sensitivity to dietary Pt compared to the form of the P in the diet reflects the extensive catabolism of at least dietary Pp.

Fluxes were generally much less sensitive to the 10 model parameters that define the major components of the model underscoring the importance of precise and accurate definition of model inputs when attempting to derive model parameters. Given the sequential nature of many of the equations, it is not surprising that parameters defining upstream degradation of Pp and Po in the rumen have an impact on quite a few fluxes. The other parameter that is quite important for many portions of the model is the rate constant for absorption of Pi from the SI.

The fluxes of Pi were insensitive to the ruminal Pp degradation rate constant ($R_{PpRum, PiRum}$) which likely reflects the model structure with a single molecule of Pi being released from Pp upon degradation and the remainder of the Pp molecule transferred to the Po pool as IP5. As noted above, the rate of degradation of Po is much less than Pp and thus Po degradation would be the rate limiting step for release of Pi in the rumen which is consistent with the observed sensitivity of the Pi pool to the rate of degradation of Po.

Blood and bone P, the latter reflected by P balance, were both sensitive to the parameters associated with Pi absorption from the SI and LI, P secretion into the rumen, and the rate constant for bone synthesis. As can be seen from Figure 1, these fluxes are the largest, and thus

most influential ones in terms of P entry, storage, and excretion. Thus it is not surprising that they have significant influence on the blood and bone pool sizes.

Conclusions

The data were adequate to parameterize the digestive elements of the model with good precision, and the model structure appears to be appropriate given the lack of significant mean and slope bias. Some predictions had large RMSPE on a percent basis, but the absolute errors approximated the expected variation associated with making the animal measurements. Phytate is greater than 90% available in the animal, but surprisingly, non-phytate organic P was not digested in the SI although it was extensively degraded in the rumen and LI. Phosphorus release from phytate appears to be much faster than degradation of lower inositol phosphate molecules, and thus the rate limiting step is not at phytase. As previously observed, the LI absorbs 15% of the Pi supply available in that compartment. Phosphorus balance is primarily regulated by changes in absorption rate from the SI and recycling of blood Pi to the rumen, and these fluxes are configured to absorb much more P than required and recycle the unused portion to the rumen. Urinary P excretion plays essentially no role in regulating P balance in bovine. Note that although the model explained the data used with no apparent bias, this does not guarantee that the model parameters are valid for all conditions. As additional data become available, it will become apparent whether this model truly has merit.

Acknowledgements

Funding for this work was provided by USDA-AFRI grant #2009-55206-05267s, by the Virginia Agricultural Experiment Station and the Hatch Program of the National Institute of Food and Agriculture, U.S. Department of Agriculture. The authors acknowledge Dr. Partha Ray

for providing help in data collation and technical advice. The critical comments of Dr. Robin White are gratefully acknowledged.

References

- Ahvenjarvi, S., A. Vanhatalo, P. Huhtanen, and T. Varvikko. 2000. Determination of reticulo-rumen and whole stomach digestion in lactating cows by omasal canal or duodenal sampling. *Br. J. Nutr.* 83:67-77.
- Ammerman, C. B., J. M. Wing, B. G. Dunavant, W. K. Robertson, J. P. Feaster, and L. R. Arrington. 1967. Utilization of inorganic iron by ruminants as influenced by form of iron and iron status of the animal. *J Anim Sci* 26:404-410.
- Anderson, R. J. 1915. The hydrolysis of phytin by the enzyme phytase contained in wheat bran. *J. Biol. Chem.* 20:475-482.
- AOAC. 1984a. Official methods of analysis. 14th ed. Asso. Off. Anal. Chem. Arlington, VA.
- AOAC. 1984b. Official methods of analysis. 14th ed. Association of official analytical chemists. Arlington, VA.
- Beede, D. K. 2005. Assessment of water quality and nutrition for dairy cattle in Mid-South ruminant nutrition conference. Arlington, TX.
- Benzie, D., A. W. Boyne, A. C. Dalgarno, J. Duckworth, and R. Hill. 1959. The relationship between phosphorus intake and resorption and repair of the skeleton in pregnancy and lactation. *J. Agri. Sci.* 52:1-12.
- Biddy, J. and H. Toutenberg. 1977. Prediction and improved estimation in linear models. Wiley, Chichester, UK.
- Blomstrand, R. 1955. The intestinal absorption of phospholipids in the rat. *Acta Physiologica Scandinavica* 34:147-157.
- Bortolussi, G., J. H. Ternouth, and N. P. McMeniman. 1996. Dietary nitrogen and phosphorus depletion in cattle and their effects on liveweight gain, blood metabolite concentrations and phosphorus kinetics. *J. Agri. Sci.* 126:493-501.
- Boyne, R. and J. R. Arthur. 1986. Effects of molybdenum or iron induced copper deficiency on the viability and function of neutrophils from cattle. *Research in Veterinary Science* 41:417-419.

- Braithwaite, G. D. 1983. Calcium and phosphorus requirements of the ewe during pregnancy and lactation. 2. Phosphorus. . Br. J. Nutr. 50:723–736.
- Bravo, D., C. Bogaert, F. Meschy, and D. Sauvant. 2003a. Plasma phosphorus content and dietary phosphorus availability in adult sheep. Anim. Res. 52:427-435.
- Bravo, D., F. Meschy, C. Bogaert, and D. Sauvant. 2002. Effects of fungal phytase addition, formaldehyde treatment and dietary concentrate on ruminal phosphorus availability. Anim. Feed Sci. and Technol. 99:73-95.
- Bravo, D., D. Sauvant, C. Bogaert, and F. Meschy. 2003b. Quantitative aspects of phosphorus excretion in ruminants. Reprod. Nutr. Dev. 43:285-300.
- Bremner, I. and A. C. Dalgarno. 1973. Iron metabolism in the veal calf. The availability of different iron compounds. Br. J. Nutr. 29:229.
- Breves, G., R. Ross, and H. Holler. 1985. Dietary phosphorus depletion in sheep: Effects on plasma inorganic phosphorus, calcium, 1,25-(oh)₂-vit-d₃ and alkaline phosphatase and on gastrointestinal p and ca balances. J. Agric. Sci. 105:623-629.
- Breves, G. and B. Schroder. 1991. Comparative aspects of gastrointestinal phosphorus metabolism. Nutr. Res. Rev. 4:125-140.
- Bullen, J. J., H. J. Rogers, and E. Griffiths. 1978. Role of iron in bacterial infection. Curr Top Microbiol Immunol 80:1-35.
- Campbell, M. H. and J. K. Miller. 1998. Effect of supplemental dietary vitamin e and zinc on reproductive performance of dairy cows and heifers fed excess iron. J Dairy Sci 81:2693-2699.
- Care, A. D. 1994. The absorption of phosphate from the digestive tract of ruminant animals. Br. Vet. J. 150:197-205.
- Care, A. D., J. P. Barlet, and H. M. Abdel-Hafeez. 1980. Calcium and phosphorus homeostasis in ruminants and its relationship to the etiology and prevention of parturient paresis. Pages 429-446 in Proc.

5th International Symposium on Ruminant Physiology. eds Y. Ruckebusch & P. Thivend. Lancaster: MTP Press.

Casey, D., P. N. Nemetz, and D. H. Uneyo. 1983. Sampling frequency for water quality monitoring: Measures of effectiveness. *Water Resources Res.* 19:1107-1110.

Challa, J. and G. D. Braithwaite. 1989. Phosphorus and calcium metabolism in growing calves with special emphasis on phosphorus homeostasis. 4. Studies on milk-fed calves given different amounts of dietary phosphorus but a constant intake of calcium. *J. Agric. Sci.* 113:285-289.

Chase, C. R., D. K. Beede, H. H. Van Horn, J. K. Shearer, T. C. J. Wilcox, and G. A. Donovan. 2000. Responses of lactating dairy cows to copper source, supplementation rate, and dietary antagonist (iron). *J Dairy Sci* 83:1845-1852.

Chicco, C. F., C. B. Ammerman, J. E. Moore, W. Von, L. R. Arrington, and R. L. Shirley. 1965. Utilization of inorganic ortho-, meta- and pyrophosphates by lambs and by cellulolytic rumen microorganisms in vitro. *J. Anim. Sci.* 24:355-363.

Cordell, D. 2008. 8 reasons why we need to rethink the management of phosphorus resources in the global food system. The story of p information sheet 1, global phosphorus research initiative, institute for sustainable futures, university of technology, sydney (uts) australia and department of water and environmental studies, linköping university (liu) sweden.

Coup, M. R. and A. G. Campbell. 1964. The effect of excessive iron intake upon the health and production of dairy cows. *Journal of Agricultural Research* 7:15.

Deobald, H. J. and C. A. Elvehjem. 1935. The effect of feeding high amounts of soluble iron and aluminum salts. *American Journal of physiology* 111:118-123.

Dias, R. S., E. Kebreab, D. M. Vitti, A. P. Roque, I. C. Bueno, and J. France. 2006. A revised model for studying phosphorus and calcium kinetics in growing sheep. *J. Anim. Sci.* 84:2787-2794.

Dias, R. S., E. Kebreab, D. M. S. S. Vitti, F. P. Portilho, H. Louvandini, and J. France. 2007. Phosphorus kinetics in lambs fed different levels of dicalcium phosphate. *Journal of Agricultural Science* 145:509-516.

- Dias, R. S., S. Lopez, R. M. Patino, T. S. Silva, J. C. Silva Filho, D. M. Vitti, M. R. Pecanha, E. Kebreab, and J. France. 2011. An extended model of phosphorus metabolism in growing ruminants. *J. Anim. Sci.* 89:4151-4162.
- Durand, M. and R. Kawashima. 1980. Influence of minerals in rumen microbial digestion. Pages 375–408 in *Digestive physiology and metabolism in ruminants*. Y. Ruckebusch and P. Thivend, ed. AVI Publishing Company Inc., Westport, CT.
- Duskova, D., R. Dvorak, V. Rada, J. Doubek, and M. Marounek. 2001. Concentration of phytic acid in faeces of calves fed starter diets. *Acta Vet. Brno* 70:381-385.
- Ellis, L. C. and A. D. Tillman. 1961. Utilization of phytin phosphorus in wheat bran by sheep *J. Anim. Sci.* 20:606-607.
- Erickson, G. E., T. J. Klopfenstein, C. T. Milton, D. Brink, M. W. Orth, and K. M. Whittet. 2002. Phosphorus requirement of finishing feedlot calves. *J. Anim. Sci.* 80:1690-1695.
- Erickson, G. E., T. J. Klopfenstein, C. T. Milton, D. Hanson, and C. Calkins. 1999. Effect of dietary phosphorus on finishing steer performance, bone status, and carcass maturity. *J. Anim. Sci.* 77:2832-2836.
- Feng, X., J. P. Jarrett, P. P. Ray, L. Karpinski, B. Willing, and K. F. Knowlton. 2011. Effect of abomasal inorganic phosphorus infusion on phosphorus absorption in lactating dairy cow (personal communication).
- Feng, X., K. F. Knowlton, A. D. Dietrich, and S. Duncan. 2013. Effect of abomasal ferrous lactate infusion on phosphorus absorption in lactating dairy cows. *J. Dairy Sci.* 96:4586-4591.
- Feng, X., H. Schramm, E. Ronk, M. McCann, M. Hanigan, and K. Knowlton. 2015. Effect of different dietary phosphorus on intestinal p absorption on growing holstein steers. *J. Dairy Sci.* 98:3410-3416.
- Field, A. C., J. Kamphues, and J. A. Woolliams. 1983. The effect of dietary intake of calcium and phosphorus on the absorption and excretion of phosphorus in chimaera-derived sheep. *J. Agric. Sci.* 101:597-602.
- Firkins, J. L., M. S. Allen, B. S. Oldick, and N. R. St-Pierre. 1998. Modeling ruminal digestibility of carbohydrates and microbial protein flow to the duodenum. *J. Dairy Sci.* 81:3350-3369.

France, J. and R. C. Siddons. 1986. Determination of digesta flow by continuous marker infusion. *J. Theor. Biol.* 121:105-119.

Frazer, D. M. and G. J. Anderson. 2005. Iron imports. I. Intestinal iron absorption and its regulation. *Am J Physiol Gastrointest Liver Physiol* 289:G631-635.

Furugouri, K. 1972. Effect of elevated dietary levels of iron on iron store in liver, some blood constituents and phosphorus deficiency in young swine. *J Anim Sci* 34:573-577.

Gartner, R. J. W. 1982. Effect of induced, subclinical phosphorus deficiency on feed intake and growth of beef heifers. *J. Agric. Sci.* 98:23-29.

Geisert, B. G., G. E. Erickson, T. J. Klopfenstein, C. N. Macken, M. K. Luebbe, and J. C. MacDonald. 2010. Phosphorus requirement and excretion of finishing beef cattle fed different concentrations of phosphorus. *J. Anim. Sci.* 88:2393-2402.

Genther, O. N. 2011. Investigation of iron concentration, valence, and source effects on short-term iron(fe) status and drinking water preference of lactation dairy cows. in *Animal Science*. Vol. M.S. Michigan State University.

Ghasemian Karyak, O., S. Safi, A. Rahimi Froushani, and M. Bolourchi. 2011. Study of the relationship between oxidative stress and subclinical mastitis in dairy cattle. *Iranian Journal of Veterinary Research* 12:350-353.

Grace, N. D. 1981. Phosphorus kinetics in sheep. *Br. J. Nutr.* 45:367-374.

Grace, N. D., M. J. Ulyatt, and J. C. Macrae. 1974. Quantitative digestion of fresh herbage by sheep: Iii. The movement of mg, ca, p, k and na in the digestive tract. *J. Agric. Sci.* 82:321-330.

Guyton, A. D., K. M. Burkholder, J. M. McKinney, and K. F. Knowlton. 2003a. The effect of steam flaked or ground corn and supplemental phytic acid on p partitioning and ruminal phytase activity in lactating cows. *J Dairy Sci* In Press:

Guyton, A. D., J. M. McKinney, and K. F. Knowlton. 2003b. The effect of steam-flaked or dry ground corn and supplemental phytic acid on phosphorus partitioning and ruminal phytase activity in lactating cows. *J. Dairy Sci.* 86:3972-3982.

Harmon, B. G., D. E. Becker, A. H. Jensen, and H. W. Norton. 1968. Effect of Na₂EDTA in diets of different iron on utilization of calcium, phosphorus and iron by rats. *J. Anim. Sci.* 27:

Haro, I. M., R. D. Brink, and J. M. Haro. 2009. Effects of inclusion of different levels of iron in lamb diets on apparent absorption and retention of phosphorus. *Journal of Animal and Veterinary Advances* 8:19-22.

Harrison, G. A., K. A. Dawson, and R. W. Hemken. 1992. Effects of high iron and sulfate ion concentrations on dry matter digestion and volatile fatty acid production by ruminal microorganisms. *J. Anim. Sci.* 70:1188-1194.

Harrison, J., K. F. Knowlton, B. James, M. D. Hanigan, C. Stallings, and E. Whitefield. 2012. Case study : National survey of barriers related to precision phosphorus feeding. *Prof. Anim. Sci.* 28:564-568.

Harvatine, D. I., J. E. Winkler, M. Devant-Guille, J. L. Firkins, N. R. St-Pierre, B. S. Oldick, and M. L. Eastridge. 2002. Whole linted cottonseed as a forage substitute: Fiber effectiveness and digestion kinetics. *J. Dairy Sci.* 85:1988-1999.

Hill, B. E., S. L. Hankins, J. F. Kearney, J. D. Arseneau, D. T. Kelly, S. S. Donkin, B. T. Richert, and A. L. Sutton. 2002. Effects of feeding low phytic acid corn and phytase on phosphorus balance in lactating dairy cows. *J. Dairy Sci.* 85 (Suppl. 1):44.

Hill, S. R., K. F. Knowlton, E. Kebreab, J. France, and M. D. Hanigan. 2008. A model of phosphorus digestion and metabolism in the lactating dairy cow. *J. Dairy Sci.* 91:2021-2032.

Hoeller, H., A. Figge, J. Richter, and G. Breves. 1988. Calcium and inorganic phosphate net absorption from the sheep colon and rectum perfused in vivo. *J. Anim. Phys. Anim. Nutr.* 59:9-15.

Holler, H., A. Figge, J. Richter, and G. Breves. 1988. Calcium and inorganic phosphate net absorption from the sheep colon and rectum perfused in vivo. *J. Anim. Phys. Anim. Nutr.* 59:9-15.

- Hubbert, F., J. E. Cheng, and W. Burroughs. 1958. Mineral requirement of rumen microorganisma for cellulose digestion *in vitro*. J. Anim. Sci. 17:559-568.
- Jackson, J. A., D. L. Langer, and R. W. Hemken. 1988. Evaluation of content and source of phosphorus fed to dairy calves. J. Dairy Sci. 71:2187-2192.
- Jarrett, J. P., J. W. Wilson, P. P. Ray, and K. F. Knowlton. 2014. The effects of forage particle length and exogenous phytase inclusion on phosphorus digestion and absorption in lactating cows. J. Dairy Sci 97:411-418.
- Jomova, K. and M. Valko. 2011. Importance of iron chelation in free radical-induced oxidative stress and human disease. Curr Pharm Des 17:3460-3473.
- Kebreab, E., J. A. N. Mills, L. A. Crompton, A. Bannink, J. Dijkstra, W. J. J. Gerrits, and J. France. 2004. An integrated mathematical model to evaluate nutrient partition in dairy cattle between the animal and its environment. Animal Feed Science and Technology 112:131-154.
- Kebreab, E., N. E. Odongo, B. W. McBride, M. D. Hanigan, and J. France. 2008. Phosphorus utilization and environmental and economic implications of reducing phosphorus pollution from ontario dairy cows. J Dairy Sci 91:241-246.
- Kebreab, E., M. A. Shah, D. E. Beever, D. J. Humphries, J. D. Sutton, J. France, and I. Mueller-Harvey. 2005. Effects of contrasting forage diets on phosphorus utilisation in lactating dairy cows. Livest. Prod. Sci. 93:125-135.
- Kincaid, R. L. and M. Rodehutsord. 2005. Phosphorus metabolism in the rumen. . Pages 187-194 in Nitrogen and phosphorus nutrition of cattle. Reducing the environmental impact of cattle operations. E. Pfeffer and A. N. Hristov, ed. CABI Publishing, Wallingford, UK.
- Knowlton, K. F. and J. H. Herbein. 2002. Phosphorus partitioning during early lactation in dairy cows fed diets varying in phosphorus content. J. Dairy Sci. 85:1227-1236.

Knowlton, K. F., J. H. Herbein, M. A. Meister-Weisbarth, and W. A. Wark. 2001. Nitrogen and phosphorus partitioning in lactating holstein cows fed different sources of dietary protein and phosphorus. *J Dairy Sci* 84:1210-1217.

Knowlton, K. F., M. S. Taylor, S. R. Hill, C. Cobb, and K. F. Wilson. 2007. Manure nutrient excretion by lactating cows fed exogenous phytase and cellulase. *J. Dairy Sci* 90:4356-4360.

Komisarczuk, S., R. J. Merry, and A. B. McAllan. 1987. Effect of different levels of phosphorus on rumen microbial fermentation and synthesis determined using a continuous culture technique. *Br. J. Nutr.* 57:279-290.

Koong, L. J., M. B. Wise, and E. R. Barrick. 1970. Effect of elevated dietary levels of iron on the performance and blood constituents of calves. *J Anim Sci* 31:422-427.

Lassiter, J. W. 1967. Effect of phosphorus on the net absorption of minerals in coastal hay fed to sheep. *Georgia Academy of science* 25:65.

Liao, S. F., A. K. Kies, W. C. Sauer, Y. C. Zhang, M. Cervantes, and J. M. He. 2005. Effect of phytase supplementation to a low- and a high-phytate diet for growing pigs on the digestibilities of crude protein, amino acids, and energy. *J. Anim. Sci.* 83:2130-2136.

Looper, M. L. and D. N. Waldner. 2002. Water for dairy cattle. New Mexico State University, Cooperative Extension Service.

Maenz, D. D., C. M. Engele-Schaan, R. W. Newkirk, and H. L. Classen. 1999. The effect of minerals and mineral chelators on the formation of phytase-resistant and phytase-susceptible forms of phytic acid in solution and in a slurry of canola meal. *Animal Feed Science and Technology* 81:177-192.

Martinez, A. and D. C. Church. 1970. Effect of various mineral elements on *in vitro* rumen cellulose digestion. *J Animal Sci.* 31:982-990.

McDowell, L. R. 1992. Minerals in animal and human nutrition. *Animal feeding and nutrition*. Academic Press, San Diego.

McGuire, S. O., W. J. Miller, R. P. Gentry, M. W. Neathery, S. Y. Ho, and D. M. Blackmon. 1985. Influence of high dietary iron as ferrous carbonate and ferrous sulfate on iron metabolism in young calves. *J Dairy Sci* 68:2621-2628.

Miller, W. J. 1981. Mineral and vitamin nutrition of dairy cattle. *J Dairy Sci* 64:1196-1206.

Minihane, A. M. and G. Rimbach. 2002. Iron absorption and the iron binding and anti-oxidant properties of phytic acid. *International Journal of Food Science and Technology* 37:741-748.

Mogodinyai, K. K. and K. Holtenius. 2012. Phosphorus net absorption in dairy cows subjected to abomasal infusion of inorganic phosphorus – a pilot study. *J Anim Physiol Anim Nutr (Berl)* 1-4.

Morse, D., H. H. Head, and C. J. Wilcox. 1992. Disappearance of phosphorus in phytate from concentrates in vitro and from rations fed to lactating dairy cows. *J. Dairy Sci.* 75:1979-1986.

NRC. 1996. Nutrient requirements of beef cattle (7th ed.). National Academy Press, Washington, DC.

NRC. 2001. Nutrient requirements of dairy cattle. 7th rev. Ed. Ed. Natl. Acad. Press, Washington dc.

Nutrient requirements of dairy cattle. 2001. Page 139. 7th rev. ed. National Academy Press, Washington, D.C.

Park, W. Y., T. Matsui, and H. Yano. 2002a. Post-ruminal phytate degradation in sheep. *Animal Feed Science and Technology* 101:55-60.

Park, W. Y., T. Matsui, and H. Yano. 2002b. Post-ruminal phytate degradation in sheep. *Anim. Feed Sci. Technol.* 101:55-60.

Pecelunas, K. S., D. P. Wages, and J. D. Helm. 1999. Botulism in chickens associated with elevated iron levels. *Avian Diseases* 43:783-787.

Poppi, D. P. and J. H. Ternouth. 1979. Secretion and absorption of phosphorus in the gastro-intestinal tract of sheep fed on 4 diets. *Australian Journal of Agricultural Research* 30:503-512.

Powell, M. J. D. 1970. A fortran subroutine for solving systems of nonlinear algebraic equations. in *Numerical methods for nonlinear algebraic equations*. P. Rabinowitz, ed, Gordon and Breach Science Publishers, London.

Prabowo, A., J. W. Spears, and L. Goode. 1988. Effects of dietary iron on performance and mineral utilization in lambs fed a forage-based diet. *J Anim Sci* 66:2028-2035.

Puggaard, L., N. B. Kristensen, and J. Sehested. 2011. Effect of decreasing dietary phosphorus supply on net recycling of inorganic phosphate in lactating dairy cows. *J. Dairy Sci.* 94:1420-1429.

Ray, P. P., J. Jarrett, and K. F. Knowlton. 2013. Effect of dietary phytate on phosphorus digestibility in dairy cows. *J. Dairy Sci.* 96:1156-1163.

Ray, P. P., C. Shang, R. O. Maguire, and K. F. Knowlton. 2012a. Quantifying phytate in dairy digesta and feces: Alkaline extraction and high-performance ion chromatography. *J Dairy Sci* 95:3248-3258.

Ray, P. P., C. Shang, R. E. Pearson, and K. F. Knowlton. 2012b. Disappearance of infused phytate from the large intestine of dairy heifers. *J. Dairy Sci.* 95:5927-5935.

Ray, P. P., C. Shang, R. E. Pearson, and K. F. Knowlton. 2012c. Disappearance of infused phytate from the large intestine of dairy heifers. *J Dairy Sci* 95:5927-5935.

Rosa, I. V., P. R. Henry, and C. B. Ammerman. 1982. Interrelationship of dietary phosphorus, aluminum and iron on performance and tissue mineral composition in lambs. *J. Animal Sci.* 55:1231-1240.

Sabbagh, Y., S. P. O'Brien, W. P. Song, J. H. Boulanger, A. Stockmann, C. Arbeeny, and S. C. Schiavi. 2009. Intestinal npt2b plays a major role in phosphate absorption and homeostasis. *J. Am. Soc. Nephrol.* 20:2348-2358.

Saltelli, A., S. Tarantola, and K. P. S. Chan. 1999. A quantitative mode independent method for global sensitivity analysis of model output. *Technometrics* 41:39-56.

SAS Institute. 2008. *Sas/stat*[®] 9.2 user's guide. Cary, NC: SAS Institute Inc.

Scharrer, E. 1985. Phosphate absorption at different intestinal sites in the developing lamb. *Q. J. Exp. Physiol Cogn. Med. Sci.* 70:615-621.

Schneider, K. M., R. C. Boston, and D. D. Leaver. 1987. Quantitation of phosphorus excretion in sheep by compartmental analysis. 252 720–731.

- Schneider, K. M., J. H. Ternouth, C. C. Sevilla, and R. C. Boston. 1985. A short-term study of calcium and phosphorus absorption in sheep fed on diets high and low in calcium and phosphorus. *Aust. J. Agric. Res.* 36:91-105.
- Schwab, E. C., C. G. Schwab, R. D. Shaver, C. L. Girard, D. E. Putnam, and N. L. Whitehouse. 2006. Dietary forage and nonfiber carbohydrate contents influence b-vitamin intake, duodenal flow, and apparent ruminal synthesis in lactating dairy cows. *J Dairy Sci* 89:174-187.
- Scott, D. and W. Buchan. 1985. The effects of feeding either roughage or concentrate diets on salivary phosphorus secretion, net intestinal phosphorus absorption and urinary phosphorus excretion in the sheep. *Q J Exp Physiol* 70:365-375.
- Scott, D. and W. Buchan. 1987. The effects of feeding either hay or grass diets on salivary phosphorus secretion, net intestinal phosphorus absorption and on the partition of phosphorus excretion between urine and feces in the sheep. *Quarterly Journal of Experimental Physiology and Cognate Medical Sciences* 72:331-338.
- Scott, D., A. F. McLean, and W. Buchan. 1984. The effect of variation in phosphorus intake on net intestinal phosphorus absorption, salivary phosphorus secretion and pathway of excretion in sheep fed roughage diets. *Q. J. Exp. Physiol.* 69:439-452.
- Scott, D., F. G. Whitelaw, W. Buchan, and L. A. Bruce. 1985. The effect of variation in phosphorus intake on salivary phosphorus secretion, net intestinal phosphorus absorption and faecal endogenous phosphorus excretion in sheep. *J. Agric. Sci.* 105:
- Sims, J. T. 1992. Environmental management of phosphorus in agricultural and municipal wastes. Pages 59-64 in *Future directions for agricultural phosphorus research*. Natl. Fert. Environ, Res. Center. TVA, Muscle Shoals, AL.
- Sklan, D. and S. Hurwitz. 1985. Movement and absorption of major minerals and water in ovine gastrointestinal tract. *J. Dairy Sci.* 68:1659-1666.

- Smith, R. A. and R. B. Alexander. 2000. Sources of nutrients in the nation's watersheds. in *Managing nutrients and pathogens from animal agriculture*. Natural resource, Agriculture, and Engineering Service (NRAES), Camp Hill, PA.
- Smith, V. H., G. D. Tilman, and J. C. Nekola. 1999. Eutrophication: Impacts of excess nutrient inputs on freshwater, marine, and terrestrial ecosystems. *Environ. Pollut.* 100:179-196.
- Socha, M. T., S. M. Ensley, D. J. Tomlinson, and A. B. Johnson. 2003. Variability of water composition and potential impact on animal performance. *Proc. Intermountain nutr. Conf.* Pp 85-96.
- Spears, J. 2009. Trace mineral nutrition-what is important and where do organic trace minerals fit in?
- Standish, J. F., C. B. Ammerman, A. Z. Palmer, and C. F. Simpson. 1971. Influence of dietary iron and phosphorus on performance, tissue mineral composition and mineral absorption in steers. *J Anim Sci* 33:171-178.
- Standish, J. F., C. B. Ammerman, C. F. Simpson, F. C. Neal, and A. Z. Palmer. 1969. Influence of graded levels of dietary iron, as ferrous sulfate, on performance and tissue mineral composition of steers. *J Anim Sci* 29:496-503.
- Ternouth, J. H. 1968. Changes in the thiosulphate space and some constituents of the blood of sheep after feeding. *Res. vet. Sci.* 9:345-349.
- Ternouth, J. H. 1990. Phosphorus and beef-production in northern australia .3. Phosphorus in cattle - a review. *Tropical Grasslands* 24:159-169.
- Ternouth, J. H., H. M. S. Davies, J. T. B. Milton, M. W. Simpsonmorgan, and N. E. Sands. 1985. Phosphorus-metabolism in ruminants.1. Techniques for phosphorus depletion. *Aust. J. Agric. Res.* 36:637-645.
- Thomas, J. W. 1970. Metabolism of iron and maganese. *J. Dairy Sci.* 53:1107.
- Tolleson, D. R. and L. L. Erlinger. 1989. An improved harness for securing fecal collection bags to grazing cattle. *Journal of Range Management* 42:396-399.
- Under wood, E. J. and N. F. Suttle. 1999. *The mineral nutrition of live stock*. 3rd ed. CABI, New York.

- Valk, H., L. B. J. Šebek, and A. C. Beynen. 2002. Influence of phosphorus intake on excretion and blood plasma and saliva concentrations of phosphorus in dairy cows. *J. Dairy Sci.* 85:2642-2649.
- Van Soest, P. J., J. B. Robertson, and B. A. Lewis. 1991a. Methods for dietary fiber, neutral detergent fiber, and nonstarch polysaccharides in relation to animal nutrition. *J Dairy Sci* 74:3583-3597.
- Van Soest, P. J., J. B. Robertson, and B. A. Lewis. 1991b. Methods for dietary fiber, neutral detergent fiber, and nonstarch polysaccharides in relation to animal nutrition. *J. Dairy Sci.* 74:3583-3597.
- Verbic, J., X. B. Chen, N. A. MacLeod, and E. R. Ørskov. 1990. Excretion of purine derivatives by ruminants. Effect of microbial nucleic acid infusion on purine derivative excretion by steers. *J. Agri. Sci.* 114:243-248.
- Vitti, D. M., E. Kebreab, J. B. Lopes, A. L. Abdalla, F. F. De Carvalho, K. T. De Resende, L. A. Crompton, and J. France. 2000. A kinetic model of phosphorus metabolism in growing goats. *J. Anim. Sci.* 78:2706-2712.
- Wasserman, R. H. and A. N. Taylor. 1976. Gastrointestinal absorption of calcium and phosphate. . *Handbook of physiology. Sec 7: Endocrinology. Vol. Vii, parathyroid gland. Washington, D. C. Am. Physiol. Soc.*
- Weiss, W. P., J. M. Pinos-Rodriguez, and M. T. Socha. 2010. Effects of feeding supplemental organic iron to late gestation and early lactation dairy cows. *J Dairy Sci* 93:2153-2160.
- Wise, M. B., S. E. Smith, and L. L. Barns. 1958. The phosphorus requirements of calves. *J. Anim. Sci.* 17:89-99.
- Witt, K. E. and F. N. Owens. 1983. Phosphorus: Ruminal availability and effects on digestion. *J. Anim. Sci.* 56:930-937.
- Wu, Z. and L. D. Satter. 2000. Milk production and reproductive performance of dairy cows fed two concentrations of phosphorus for two years. *J Dairy Sci* 83:1052-1063.

Wu, Z., L. D. Satter, A. J. Blohowiak, R. H. Stauffacher, and J. H. Wilson. 2001. Milk production, estimated phosphorus excretion, and bone characteristics of dairy cows fed different amounts of phosphorus for two or three years. *J. Dairy Sci.* 84:1738-1748.

Wu, Z., L. D. Satter, and R. Sojo. 2000. Milk production, reproductive performance, and fecal excretion of phosphorus by dairy cows fed three amounts of phosphorus. *J. Dairy Sci.* 83:1028-1041.

Wu, Z., S. K. Tallam, V. A. Ishler, and D. D. Archibald. 2003. Utilization of phosphorus in lactating cows fed varying amounts of phosphorus and forage. *J. Dairy Sci.* 86:3300-3308.

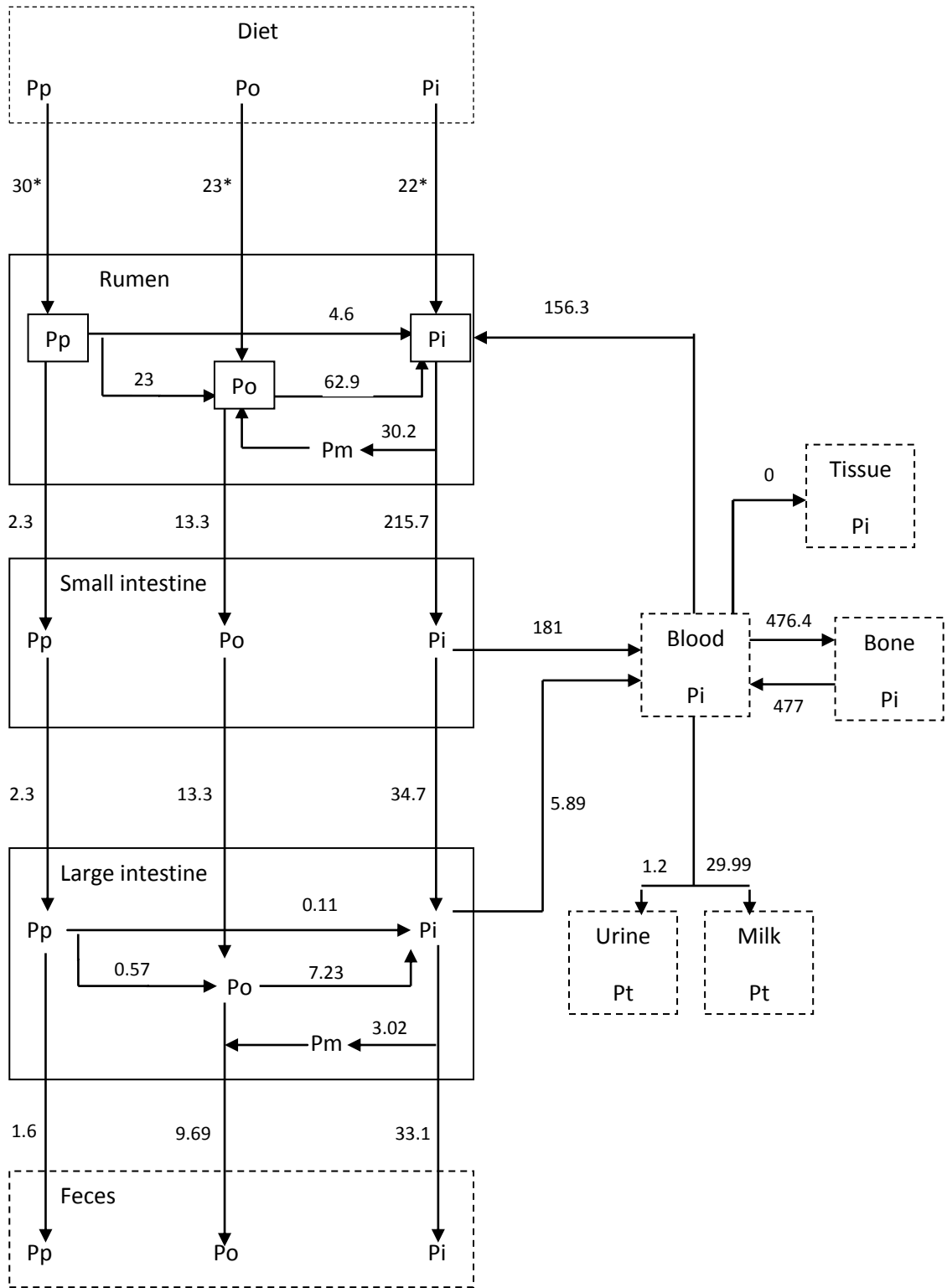

Figure 5-1 Schematic representation of P absorption and metabolism in a lactating cow producing 30 kg milk/d and consuming 23 kg/d of a reference diet formulated to match NRC (2001) P requirements. Boxes with solid lines represent pools, boxes with dashed lines represent compartments, and solid arrows represent fluxes. Numbers associated with arrows denote predicted fluxes for the reference diet using the parameters listed in Table 4. An asterisk (*) indicates an assumed flux value. Pt= total P; Pp = phytate P; Po = organic P excluding phytate; Pi = inorganic P; Pm = microbial

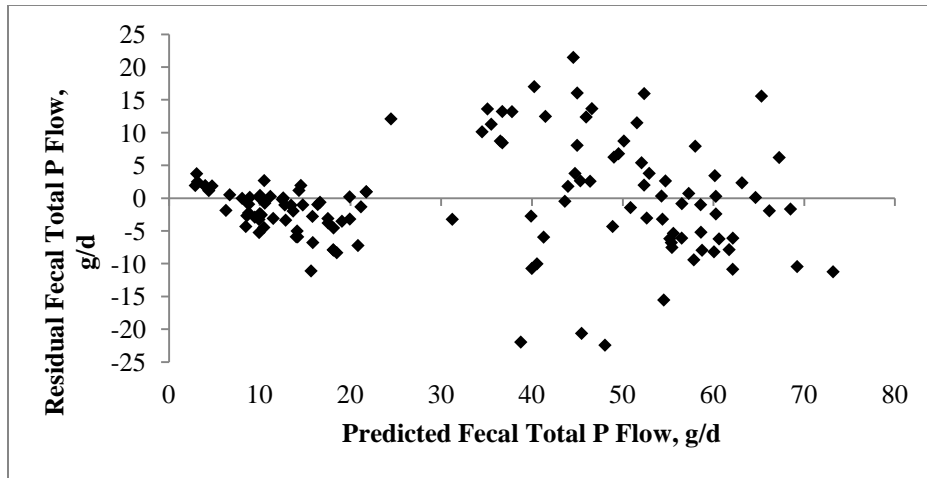

Figure 5-2 Residual errors for predictions of total fecal P flow versus predicted flow. Simulations are of the data summarized in Table 3 using inputs outlined in Table 2 and the model parameters listed in Table 4.

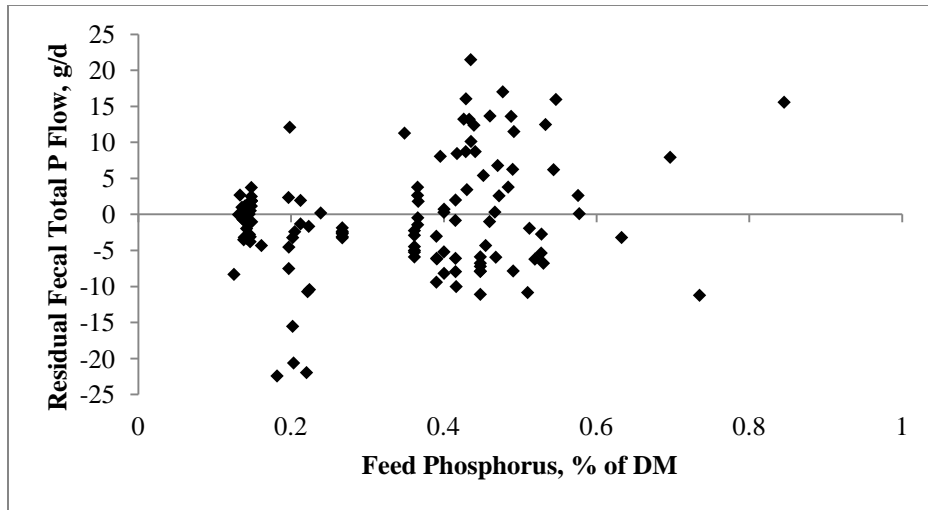

Figure 5-3 Residual errors for predictions of total fecal P flow versus the concentration of P in feed. Simulations are of the data summarized in Table 3 using inputs outlined in Table 2 and the model parameters listed in Table 4.

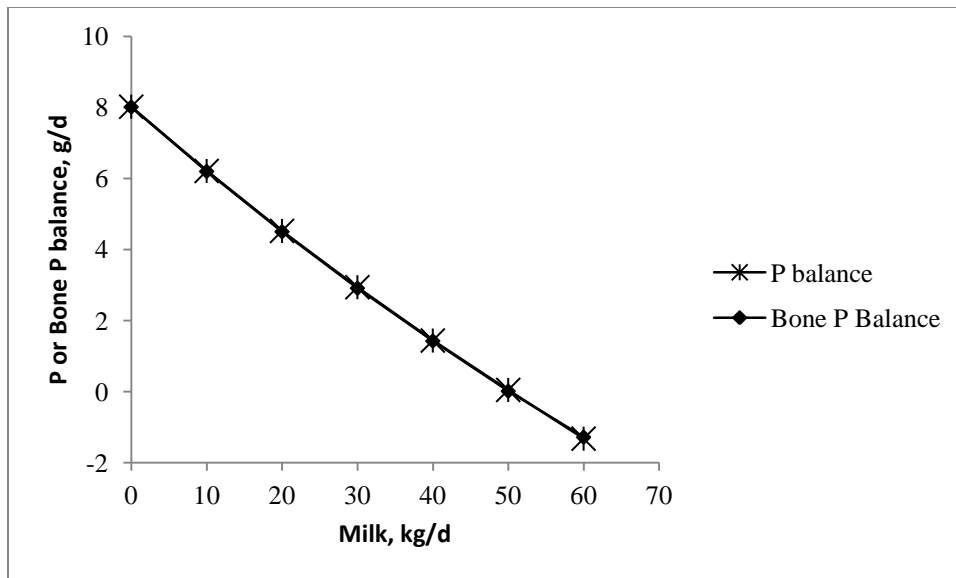

Figure 5-4 P and bone P balance in response to varied milk yield, predicted by the model using the parameters in Table 4. The dietary P (0.45 % of DM) and proportions of phytate P, organic and inorganic P (33.2%, 22.3% and 44.5% respectively) were held constant as milk yield varied. Dry matter intake was set to 23 kg/d. Slopes for P balance and Bone P balance are -0.1552 and -0.1548 g/kg milk.

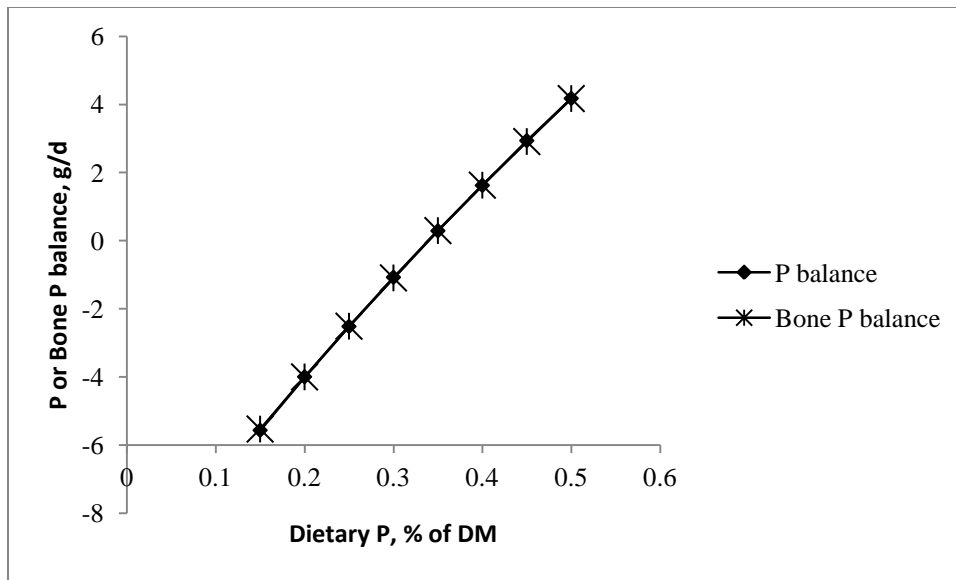

Figure 5-5 P and

bone P balance in response to varied dietary P (% of DM). as predicted by the model using the parameters in Table 4. The milk yield (30 kg/d) and proportions of phytate P, organic and inorganic P (33.2%, 22.3% and 44.5% respectively) were held constant as dietary P (% of DM) varied. Dry matter intake was set to 23 kg/d. Slopes for P balance and Bone P balance are 27.78 and 27.69 g/%.

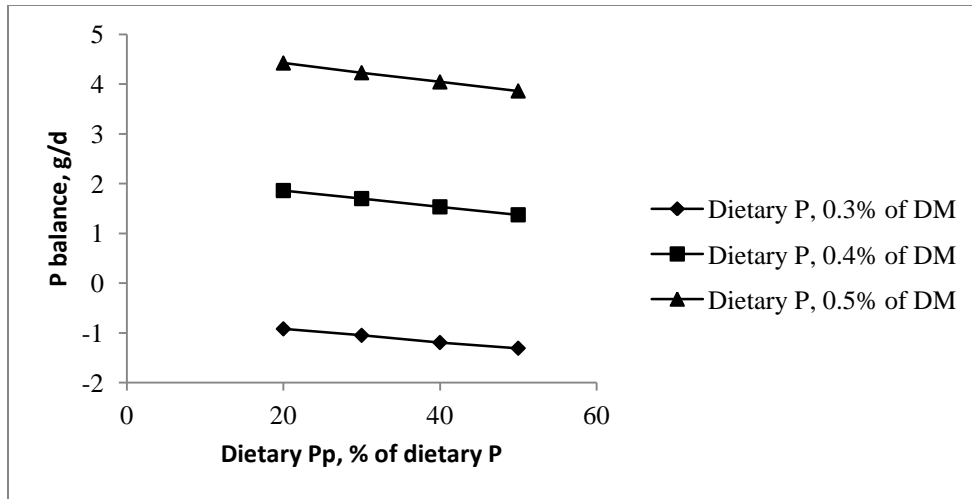

Figure 5-6 P balance in response to varied dietary P (% of DM) and varied phytate content (% of dietary P).as predicted by the model using the parameters in Table 4. Milk yield was held constant as dietary P and phytate content varied. Dry matter intake was set to 23 kg/d.

Table 5-1 Symbols used in the model

Symbol	Definition
<i>Bld</i>	Blood
<i>Bone</i>	Bone
C_a	Concentration of <i>a</i> , g/L
<i>Deg</i>	Degradation of P
<i>f</i>	Fractional rate or proportioning constant, g/g
$F_{a,b}$	Flux from pool <i>a</i> to pool <i>b</i> , g/d
<i>Fe</i>	Feces
<i>Fd</i>	Feed
<i>iCa</i> or <i>iQa</i>	Initial concentration (<i>C</i>) or mass (<i>Q</i>) of <i>a</i> , g
<i>k</i>	Apparent affinity constant, g/L
$K_{a,b}$	Mass action rate constant associated with the flux from pool <i>a</i> to pool <i>b</i> , /d
<i>LI</i>	Large intestine
<i>Mlk</i>	Milk
<i>Pi</i>	Inorganic P
<i>Pm</i>	Microbial P
<i>Po</i>	Organic P excluding phytate
<i>Pp</i>	Phytate
<i>Pt</i>	Total P
<i>Qa</i>	Quantity or mass of <i>a</i> , g
<i>R</i>	Rate constant associated with the flux from pool <i>a</i> to pool <i>b</i> , g/d
<i>Rum</i>	Rumen
<i>Sal</i>	Saliva
<i>SI</i>	Small intestine
<i>Urn</i>	Urine

Table 5-2 Model inputs for Ray et al. (2012, 2013), Feng et al. (2011, personal communication), Feng et al. (2013), Feng et al. (2015) and Jarrett et al. (2014)

Input	PR1 ⁵	PR2 ⁶	LK1 ⁷	XF2 ⁸	XF3 ⁹	JJ1 ¹⁰
<i>BW</i> , kg	419.5	463.0	537.5	582.9	187.0	470.7
Milk yield, kg/d	0	33.05	27.35	31.69	0	20.22
<i>DMI</i> , kg/d	7.66	17.12	20.84	22.80	4.94	16.75
f_{PtFd} ¹	0.0014	0.0052	0.0021	0.0039	0.0031	0.0046
f_{PpPt}	0.0352	0.3482	0.2582	0.3942	0.2441	0.3871
f_{PoPt}	0.1183	0.0697	0.0799	0.0999	0.0498	0.1026
f_{PiPt}	0.8465	0.5822	0.6619	0.5059	0.7061	0.5103
<i>MiG</i> ² , kg/d	1.52	3.21	3.64	3.84	0.88	3.16
<i>PtIleInf</i> ³ , g/d	4.5	0	0	0	0	0
<i>PiOmaInf</i> ⁴ , g/d	0	0	28.5	0	0	0

¹ f_{ab} , Fractional proportion of *a* in *b*. e.g. f_{PtFd} is proportion of Pt (total P) in Fd (feed). This also applies to f_{PpPt} , f_{PoPt} , f_{PiPt}

²Microbial growth

³Total amount of P infused in the ileum, including Pi, Pp and Po

⁴Total amount of Pi infused in the omasum

⁵Ray et al. (2012)

⁶Ray et al. (2013)

⁷Feng et al. (2011, personal communication)

⁸Feng et al. (2013)

⁹Feng et al. (2015)

¹⁰Jarrett et al. (2014)

Table 5-3 Mean of observed data for Ray et al. (2012, 2013), Feng et al. (2011, personal communication), Feng et al. (2013), Feng et al. (2015) and Jarrett et al. (2014)

Variable ¹	PR1 ²	PR2 ³	LK1 ⁴	XF2 ⁵	XF3 ⁶	JJ1 ⁷
Q_{PiRum} , g		65.99				67.19
Q_{PpRum} , g		0.59				0.27
Q_{PoRum} , g		6.98				21.96
Q_{PiRum} , g		58.42				47.48
$F_{PiRum,PiSi}$, g/d		195.94			20.70	178.42
$F_{PpRum,PpSi}$, g/d		2.78			0.90	1.29
$F_{PoRum,PoSi}$, g/d		12.50			5.96	12.43
$F_{PiRum,PiSi}$, g/d		182.89			13.84	163.97
$F_{PmRum,PiOmal}$, g/d					5.91	16.40
$F_{PiSi,PiLi}$, g/d	8.09	60.54	49.78		8.31	64.64
$F_{PpSi,PpLi}$, g/d	0.13	2.09				1.67
$F_{PoSi,PoLi}$, g/d		7.16				23.00
$F_{PiSi,PiLi}$, g/d	3.68	53.85	26.17		4.67	39.97
$F_{PmSi,PmLi}$, g/d		2.47				28.55
$F_{PiLi,PiFe}$, g/d	12.55	54.83	35.45	51.72	7.16	54.67
$F_{PpLi,PpFe}$, g/d	2.08	1.66		0.94		1.16
$F_{PoLi,PoFe}$, g/d	3.18	7.56		15.02		13.99
$F_{PiLi,PiFe}$, g/d	7.67	46.10	21.13	35.76	4.63	39.52
$F_{PmLi,PmFe}$, g/d		3.98				19.58
$F_{PiBld,PiUrn}$, g/d	1.06	0.37	0.74	1.06	0.42	1.39
$F_{PiBld,PiMlk}$, g/d		33.02	24.52	31.18		20.22
C_{PiBld} , g/L			0.06	0.07	0.07	0.06
Balance, g/d	-2.73	0.08	11.16	5.69	7.20	0.91

¹Variable abbreviations as given in Table 1

²Ray et al. (2012)

³Ray et al. (2013)

⁴Feng et al. (2011, personal communication)

⁶Feng et al. (2013)

⁶Feng et al. (2015)

⁷Jarrett et al. (2014)

Table 5-4 Model parameter estimates and standard deviations derived from fitting to the data listed in Table 2.

Parameter	Description	Estimate	STD	CV, %
$R_{PpRum, PiRum}$	Ruminal phytate degradation, g/d	67.5	5.50	8.15
$K_{PoRum, PiRum}$	Ruminal non-phytate, organic P degradation, /d	14.9	1.33	8.92
V_{PiSal}	Vmax for salivary phosphorus secretion, g/d	248.0	14.65	5.91
$f_{PiSi, PiBld}$	Small intestine fractional phosphorus absorption, g/g	0.84	0.13	16.46
$K_{PiBld, PiBone}$	Bone P deposition rate constant, /d	67.9	3.16	4.65
$R_{PiBld, PiUrn}$	Renal phosphorus clearance, g/d	1.2	0.06	5.23
R_{PiGain}	Phosphorus retention in gain, g/d	5.8	0.97	16.81
$f_{PpLi, DegLi}$	Large intestine fractional phytate degradation, g/g	0.3	0.06	20.20
$f_{PoLi, PiLi}$	Large intestine fractional organic P degradation, g/g	0.5	0.10	19.76
$f_{PiLi, PiBld}$	Large intestine fractional phosphorus absorption, g/g	0.15	0.03	21.11

Table 5-5 Model prediction errors (RMSPE) associated with prediction of the data of six studies

Variable ¹	N	Mean Observed, g/d	Mean Predicted, g/d	RMSPE, g/d	RMSPE, % of observed	Mean bias, % of MSPE	Slope bias, % of MSPE
Q_{PtRum} , g	42	66.56	57.12	15.24	22.89	38.43	16.15
Q_{PpRum} , g	29	0.51	0.53	0.25	49.25	0.96	7.81
Q_{PoRum} , g	29	10.60	4.56	10.25	96.77	34.70	2.31
Q_{PiRum} , g	42	53.21	51.97	12.28	23.08	1.02	11.16
$F_{PtRum,PtSi}$, g/d	64	119.55	123.12	38.71	32.38	0.85	9.35
$F_{PpRum,PpSi}$, g/d	56	1.53	1.11	0.97	63.45	19.05	1.63
$F_{PoRum,PoSi}$, g/d	52	9.21	8.70	12.60	136.79	0.16	3.01
$F_{PiRum,PiSi}$, g/d	62	106.20	110.09	32.52	30.62	1.43	22.83
$F_{PtSi,PtLi}$, g/d	110	34.02	32.77	11.39	33.49	1.20	6.22
$F_{PpSi,PpLi}$, g/d	70	1.18	1.18	0.69	58.59	0.01	3.73
$F_{PoSi,PoLi}$, g/d	36	15.96	14.42	12.19	76.36	1.59	0.14
$F_{PiSi,PiLi}$, g/d	108	23.26	23.28	11.65	50.08	0.00	0.38
$F_{PtLi,PtFe}$, g/d	128	33.43	33.88	7.56	22.62	0.35	0.08
$F_{PpLi,PpFe}$, g/d	84	1.53	1.48	0.69	45.36	0.56	3.58
$F_{PoLi,PoFe}$, g/d	81	9.27	10.72	4.79	51.66	9.25	1.81
$F_{PiLi,PiFe}$, g/d	124	23.76	23.31	8.61	36.25	0.27	1.74
$F_{PiBld,PiUrn}$, g/d	132	0.83	0.84	0.98	118.49	0.01	0.53
C_{PiBld} , g/L	77	0.06	0.06	0.02	24.32	19.07	14.86

<i>Balance, g/d</i>	128	3.07	3.16	8.15	265.29	0.01	0.05
---------------------	-----	------	------	------	--------	------	------

¹Variable abbreviations as given in Table 1

Table 5-6 Global sensitivity coefficients of the fitted model. Coefficients represent the proportion of output variance associated with the parameter.

Variable ¹	f_{PiFd} ²	f_{PpPi} ²	f_{PoPi} ²	f_{PiPi} ²	$R_{PpRum,Pi}$	$K_{PoRum,Pi}$	V_{PiSal}	$f_{PiSi, PiBld}$	K_{PiBld}	R_{PiBld}	R_{PiGain}	f_{PpLi}	f_{PoLi}	$f_{PiLi, PiBld}$
					<i>Rum</i>	<i>Rum</i>			<i>PiBone</i>	<i>PiUrn</i>		<i>DegLi</i>	<i>PiLi</i>	
Q_{PiRum} , g	0.722	0.108	0.027	0.095	0.0	0.0	0.004	<0.001	0.0	0.0	0.0	0.0	0.0	0.0
Q_{PpRum} , g	0.341	0.639	0.0	0.0	0.003	0.0	0.0	0.0	0.0	0.0	0.0	0.0	0.0	0.0
Q_{PoRum} , g	0.488	0.305	0.113	0.0	0.0	0.012	0.0	0.0	0.0	0.0	0.0	0.0	0.0	0.0
Q_{PiRum} , g	0.728	0.091	0.022	0.112	0.0	<0.001	0.005	<0.001	0.0	0.0	0.0	0.0	0.0	0.0
$F_{PiRum,PiSi}$, g/d	0.722	0.108	0.027	0.095	0.0	0.0	0.004	<0.001	0.0	0.0	0.0	0.0	0.0	0.0
$F_{PpRum,PpSi}$, g/d	0.341	0.639	0.0	0.0	0.003	0.0	0.0	0.0	0.0	0.0	0.0	0.0	0.0	0.0
$F_{PoRum,PoSi}$, g/d	0.488	0.305	0.113	0.0	0.0	0.012	0.0	0.0	0.0	0.0	0.0	0.0	0.0	0.0
$F_{PiRum,PiSi}$, g/d	0.728	0.091	0.022	0.111	0.0	<0.001	0.005	<0.001	0.0	0.0	0.0	0.0	0.0	0.0
$F_{PiSi,PiLi}$, g/d	0.715	0.110	0.027	0.094	0.0	0.0	0.0	<0.001	0.003	0.0	0.0	0.0	0.0	<0.001
$F_{PpSi,PpLi}$, g/d	0.341	0.639	0.0	0.0	0.003	0.0	0.0	0.0	0.0	0.0	0.0	0.0	0.0	0.0
$F_{PoSi,PoLi}$, g/d	0.488	0.305	0.113	0.0	0.0	0.012	0.0	0.0	0.0	0.0	0.0	0.0	0.0	0.0
$F_{PiSi,PiLi}$, g/d	0.722	0.092	0.022	0.111	0.0	<0.001	0.0	<0.001	0.004	0.0	0.0	0.0	0.0	<0.001
$F_{PiLi,PiFe}$, g/d	0.715	0.112	0.028	0.093	0.0	0.0	0.0	<0.001	0.003	0.0	0.0	0.0	0.0	0.0
$F_{PpLi,PpFe}$, g/d	0.324	0.608	0.0	<0.001	0.003	0.0	0.0	0.0	0.0	0.0	0.0	0.04	0	0.0
$F_{PoLi,PoFe}$, g/d	0.438	0.281	0.097	0.0	0.0	0.010	0.0	0.0	0.0	0.0	0.0	<0.0	0.0	0.0
												7	88	
												01	88	

$F_{PiLi, PiFe}$, g/d	0.719	0.101	0.025	0.102	0.0	0.0	0.0	<0.001	0.004	0.0	0.0	0.0	<0.001	0.0
$F_{PiBld, PiUrn}$, g/d	0.678	0.083	0.020	0.098	0.0	<0.001	<0.001	0.027	0.008	0.051	0.0	0.0	0.0	0.001
C_{PiBld} , g/L	0.725	0.086	0.021	0.102	0.0	<0.001	<0.001	0.029	0.009	0.0	0.0	0.0	0.0	0.001
$P_{Balance}$, g/d	<0.001	0.396	0.098	0.328	0.0	<0.001	<0.001	0.002	0.012	0.0	0.0	0.0	0.0	<0.001

¹Variable abbreviations as given in Table 1

² f_{ab} , Proportion of a in b. e.g. f_{PiFd} is proportion of Pt (total P) in Fd (feed). This also applies to f_{PpPb} , f_{PoPb} , f_{PiPt}

³Parameters abbreviations as given in Table 1

Table 5-7 P flow data for Feng et al. (2011, personal communication)

Item	P supply, % of requirement ¹				SE	P-value ²		
	50	80	110	140		Trt	Linear	Quad
Total P								
Intake, g/d	42.7	41.5	45.4	43.9	2.85	0.69	0.50	0.96
Ileal TP flow, g/d	23.8	39.9	49.4	85.9	5.76	<0.001	<0.001	0.09
Net disappearance of P from LI, g/d	6.25	12.3	15.1	23.7	3.75	0.08	0.02	0.74
Fecal TP, g/d	17.5	27.7	34.4	62.3	3.26	<0.001	<0.001	0.002
Urine TP, g/d	0.48	0.56	1.12	0.81	0.22	0.06	0.05	0.21
Milk TP, g/d	25.7	22.9	25.6	23.9	1.75	0.36	0.61	0.67
TP balance, g/d	-0.98	10.1	22.9	12.5	3.33	0.005	0.005	0.008
Inorganic phosphorus (Pi)								
Intake, g/d	27.31	27.8	31.15	27.91	1.41	0.27	0.43	0.22
Ileal Pi flow, g/d	8.19	16.2	27.4	52.9	3.40	<0.001	<0.001	0.03
Disappearance of Pi from LI, g/d	0.06	-1.64	6.36	15.4	2.64	0.01	0.004	0.09
Fecal Pi, g/d	8.13	17.8	21.0	37.6	4.03	0.003	<0.001	0.29
Serum Pi, mg/dL	3.53	5.87	6.64	6.48	0.38	0.008	0.003	0.03

¹Cows were abomasally infused with 0, 20.2, 40.2 and 60.3 g/d inorganic P (Pi) solution to supply 50, 80, 110 and 140% of their calculated P requirement.

² P-values for treatment, linear and quadratic effects

Chapter 6 SUMMARY AND CONCLUSIONS

The effect of elevated iron in drinking water on P absorption was investigated in early lactation dairy cows fed Fe-adequate diets. Abomasal infusion of up to 1250 mg Fe/d in the highly available form ferrous lactate did not affect DMI, P intake, P absorption, milk composition, or milk production. Increasing Fe infusion from ferrous lactate decreased digestibility of DM, NDF and nitrogen; additional work is needed to see if this affects lactation performance when consumption of high Fe water is sustained. In the short term, water iron up to 12.5 mg/L did not affect P status of lactating cows.

In growing Holstein steers on a high beet pulp diet fed varying concentrations of dietary P (supplemented low P basal diet with MAP) indicated effects on P metabolism with an apparent prioritization of rumen function over blood P maintenance. When P was fed below requirements, serum Pi declined but P absorption efficiency from the small intestine of Holstein steers were not affected. Salivary P was unchanged despite reduced blood P concentration suggesting rumen function was prioritized during short term of P deficiency. Of interest in the modeling effort P was absorbed on a net basis from the large intestine, though probably not biologically important to the cow since this was only a small proportion of total P absorption from the whole digestive tract and was not affected by dietary P concentration.

Data from the ferrous lactate infusion study and P absorption study above along with four other studies (Feng et al., 2011, Ray et al., 2012,2013 and Jarrett et al., 2014) were adequate to parameterize the digestive elements of an existing model (Hill et al., 2008) with good precision, and the model structure appears to be appropriate given the lack of significant mean and slope bias. Some predictions had large RMSPE on a percent basis, but the absolute errors approximated the expected variation associated with making the animal measurements. When the

updated model was compared to the original model by setting model inputs to the reference input values used in the prior work, modest changes were observed. For instance, while phytate availability to the cow was greater than 90%, non-phytate organic P was not digested in the SI but was extensively degraded in the rumen and LI. Also, P release from phytate was much faster than degradation of lower inositol phosphate molecules, and thus the rate limiting step in phytate degradation is not initial cleavage of the molecule with phytase. In these model simulations, P balance was primarily regulated by changes in rate of P absorption from the SI and recycling of blood Pi to the rumen. These fluxes are configured to absorb much more P than required and to recycle the unused portion to the rumen. Urinary P excretion plays essentially no role in regulating P balance in the bovine. Although the model explained the data used with no apparent bias, this does not guarantee that the model parameters are valid for all conditions. As additional data become available it will become apparent how universally this model can be applied.