

Virginia Cooperative Extension

# On-Farm Composting

*A Guide to Principles,  
Planning &  
Operations*

Virginia  
Cooperative  
Extension

 VirginiaTech  
*Invent the Future*



VIRGINIA STATE UNIVERSITY

Publication 452-232



# **ON FARM COMPOSTING: A GUIDE TO PRINCIPLES, PLANNING AND OPERATIONS**

Archer H. Christian and Gregory K. Evanylo  
Department of Crop & Soil Environmental Sciences

James W. Pease  
Department of Agricultural and Applied Economics

## **AKNOWLEDGEMENTS**

---

The authors wish to thank the following faculty of the College of Agriculture and Life Sciences and Virginia Cooperative Extension (VCE) for their time and valuable contributions in reviewing the manuscript for this publication: Dr. Mark M. Alley, Extension Specialist, Department of Crop & Soil Environmental Sciences; Dr. Darrell Bosch, Assoc. Professor, Department of Agricultural and Applied Economics; Dr. Eldridge Collins, Agricultural Waste Specialist, Department of Biological Systems Engineering; Charley Goodman, VCE Fluvanna County; Robert Lane, Engineer-Marine Industries, Seafood Extension Unit; and Jim Riddell, VCE Louisa County. Appreciation also goes to Dr. Leon Geyer, Professor, Department of Agricultural and Applied Economics, for his assistance in developing the section on contract issues in compost feedstock delivery and management.

This publication has been funded in part by the USDA Southern Region Sustainable Agriculture Research and Education Program.

### *Disclaimer*

Commercial companies and products are named in this publication for informational purposes only. Virginia Cooperative Extension does not endorse these companies and products and does not intend discrimination against others which may also be suitable.

COVER PHOTO: Turning compost at Cascades Farm, Rockbridge County, Virginia.  
Owners- C. Halliwill and B. Bressler.



## TABLE OF CONTENTS

---

Introduction .....	1
I. Principles.....	1
A. Overview .....	1
B. Fundamentals.....	1
C. Summary .....	4
II. Feedstocks .....	5
A. Feedstock materials.....	5
B. Compost mixes.....	7
III. Systems .....	9
A. Windrow .....	9
B. Aerated static pile .....	9
C. Passively aerated windrow.....	12
IV. Processing and Quality Guidelines .....	12
A. Process management .....	12
B. Troubleshooting .....	12
C. Water quality protection.....	12
D. Curing and storage .....	13
E. Compost quality considerations.....	13
V. Application and Benefits.....	15
VI. Planning and Siting .....	16
A. Identify goals .....	16
B. Understand the composting process .....	16
C. Assess feedstock availability .....	16
D. Determine site suitability .....	16
E. Assess projected operation economics .....	18
F. Assess the market potential if compost is to be sold.....	19
G. Investigate local and state regulatory requirements.....	20
H. Select technology level and establish operation size.....	20
I. Develop operation budget.....	20
J. Inform and educate neighbors.....	22
VII. Regulations: Understanding and Compliance .....	24
A. Yard waste composting facility regulations .....	24
B. Solid waste management regulations.....	26
Appendix A. Composting Process Record Table.....	27
Appendix B. Composting Troubleshooting and Management Guide .....	28
Appendix C. Contract Issues - Compost Feedstock Delivery/Management.....	31
Appendix D. Composting Contacts and Resources.....	34
References.....	36



## INTRODUCTION

Farmers can effectively manage manures and other wastes and create a desirable end-product by producing their own compost from organic materials generated on-farm and off-farm. These materials, many of which can be received from off-farm with minimal or no regulatory requirements, include municipal yard trimmings, fruit and vegetable residuals, and livestock manures. Composting yields an end-product that is useful as a soil amendment, improves odor control and waste handling in animal operations, and offers the potential for additional farm income from the sale of finished material and/or the receipt of tipping fees for accepting off-farm wastes. This publication contains a discussion of basic composting principles, compostable materials, composting systems, the use of compost and its benefits, guidelines for managing and solving process problems, the steps for facility planning and operation, and the regulations that govern on-farm composting.

## I. PRINCIPLES

### A. OVERVIEW

Composting is the manipulation or control of the natural decomposition of organic matter. It requires optimizing the conditions for the mixed population of microorganisms (mainly bacteria, fungi and actinomycetes) responsible for the decomposition. These microbes, normally found on the surface of leaves, grass clippings and other organic materials, thrive in a warm, moist, aerobic (oxygen rich) environment.

During decomposition, the microorganisms multiply and liberate carbon dioxide ( $\text{CO}_2$ ), water, other organic products and energy. Some of the energy is used in metabolism and the remainder is given off as heat (Figure 1). Eventually, the readily-available food supply is exhausted, microbial growth and heat generation decrease, and a humus-like material remains. This material is called compost.

The following fundamental principles describe the decomposition of raw materials, and illustrate how to optimize that process for efficient composting and the successful production of compost.

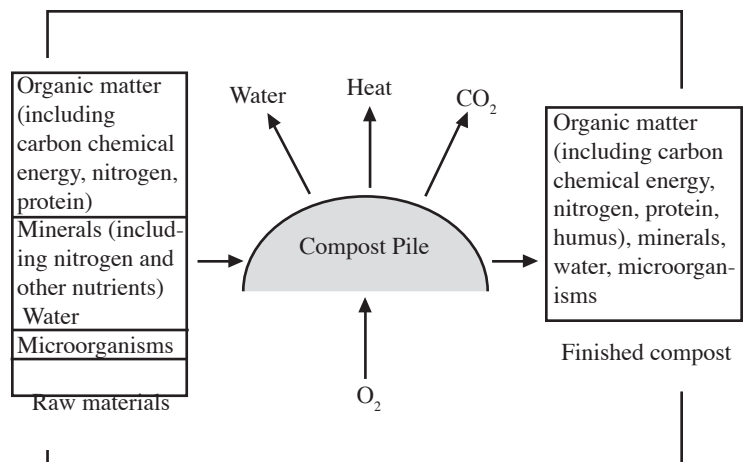

Figure 1. The Composting Process (Reprinted with permission from *On-Farm Composting Handbook*, NRAES, 1992.)

### B. FUNDAMENTALS

The natural process of breakdown can be accelerated by gathering the organic waste material into piles. When organic wastes are gathered into sufficiently large piles for composting, the natural insulating effect of the material leads to a conservation of heat and a marked rise in temperature. The heat given off by the microorganisms further increases the temperature. The temperature rise inside the pile is due to the difference between the heat generated by the microbes and the heat lost to the surroundings. The dimensions of the pile, particle size of the material, availability of nutrients (e.g. carbon and nitrogen), oxygen concentration, and moisture content are critical factors that affect the temperature and, therefore, the microbial population and diversity within the pile.

▪ **Microorganisms.** The microbes that inhabit a compost pile are so small that a clod of soil the size of a pea may contain millions of them. They break down the complex compounds of the waste material into simpler organic compounds.

Bacteria are the most important group of decomposing microorganisms in composting and are generally identified by the temperature range in which they are most active (Figure 2). The mesophilic bacteria thrive at temperatures of 77-108°F (25-42°C), but they can survive at higher temperatures. During their short life span at the beginning of the composting process, these bacteria feed on the most readily available carbohydrates and proteins. The heat produced

during metabolism raises the temperature in the pile beyond their viable range and causes their death. These higher temperatures are conducive to thermophilic bacteria, which perform best at temperatures ranging from 122-140°F (50-60°C). The most rapid decomposition occurs within this range. Thermophilic bacteria degrade the proteins and non-cellulose carbohydrates. Thermophilic fungi, which break down the cellulose portion of leaves, also colonize the pile at these temperatures. In addition, weed seeds, insect eggs and larvae, and potential pathogens are destroyed when temperatures remain in the upper end of the thermophilic range for several days. If the temperature rises above 140°F (60°C), the majority of the bacterial population and many other living organisms begin to perish. At temperatures below 59°F (15°C), activity of the primary decomposers is very limited.

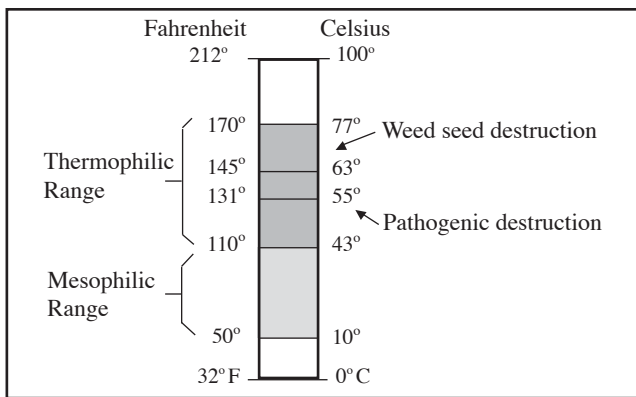

Figure 2. Temperature Ranges of Mesophilic and Thermophilic Bacteria (Adapted from McNelly, 1989)

▪ **Macroorganisms.** The outer portion of any composting pile provides a cool enough environment for the macroorganisms that also play a part in the decomposition process. Macroorganisms are many-celled organisms ranging in size from microscopic (rotifers and nematodes) to the larger fungi, mites, springtails, sowbugs, beetles and earthworms. The action of their chewing, foraging and moving through the pile helps to physically break up the materials and create a greater surface area on which bacterial action can occur.

▪ **Moisture and Oxygen.** All living things require water, and microbes are no exception. It is important to maintain a moisture content of 45 to 65 percent throughout the entire composting

process to ensure survival of the microorganisms. Incoming materials may be too dry and water may need to be added as the piles are formed. However, it is not desirable for the piles to be excessively wet. Too much water fills up the air spaces, which creates undesirable anaerobic (oxygen limiting) conditions. If composting material is too wet, mechanical mixing and aerating can facilitate drying. Absorbent bulking materials can also be added. Breathable, but water impermeable, compost covers can be used to prevent unwanted precipitation from infiltrating piles and windrows.

A quick test to determine if the moisture content of the composting material is appropriate is to squeeze a representative handful. If one or two drops of water can be squeezed out with difficulty, it is sufficiently moist. Although not essential, a moisture meter can be used for more precise measurement of water content.

Oxygen for the microbial population can be provided by both natural convection and mechanical aeration. Piles must be maintained with good particle size distribution and porosity for natural convection to occur (See *Particle Size and Structure* on page 3). Excess aeration can keep a pile too cool for optimum microbial activity. Without adequate oxygen, the aerobic bacterial population dies off, anaerobic microbes become prevalent, and fermentation occurs. This leads to the production of odorous and other undesirable gases, lower temperatures, a slower decomposition rate, and incompletely composted material. The unfinished compost can contain organic acids and other compounds harmful to plants (phytotoxic) and soil life.

▪ **C:N Ratio.** Microorganisms use carbon (C) as an energy source and nitrogen (N) to build proteins and other cell components in a proportion that averages about 15 parts C to 1 part N. These elements are found in all organic waste materials; however, this ideal carbon-to-nitrogen (C:N) ratio is not found in any one organic source, nor is all of the carbon and nitrogen in organic materials readily available to microbes.

An initial C:N ratio of approximately 30:1 (dry weight basis) is recommended for most efficient composting. This is achieved by combining



various raw materials for which concentrations of carbon and nitrogen are known. Care must be taken in establishing the mix, however, because materials vary not only in forms and concentrations of C and N, but in bulk density (weight per unit volume) and particle size, as well. A higher C:N ratio than 30:1 may be appropriate for mixes with woodchips and sawdust, because much of the carbon is present in forms that are very difficult to degrade. If too little carbon is present relative to the nitrogen (C:N<20:1), the excess nitrogen may be driven off as ammonia gas, and odor problems and nitrogen loss will occur. However, if too much carbon is present relative to the nitrogen (C:N>40:1), nitrogen becomes limiting and the composting rate will decrease.

The C:N ratio decreases as decomposition proceeds. The final C:N ratio of the material will vary depending on the initial materials used, the technology employed, how completely the material decomposes, and whether screening out any large woody particles is conducted prior to product analysis. Few unscreened composts will have ratios below 15:1.

Although C:N ratios are reported on a dry weight basis, materials are usually combined on a volume basis because most operations do not have large scales for weighing trucks or vessels. Conversions can be made when the bulk density of feedstock materials is known (See Table 2 and Compost Mixes (Section II)).

▪ **Particle Size and Structure.** Composting is affected by particle size and structure of the raw materials. Particles that are too small will pack tightly and reduce porosity in the pile. However, smaller sized particles will provide more exposed surface area than larger ones and accelerate the composting process. Particles with too little rigidity may contribute to compaction.

The compost pile should be constructed of a variety of material sizes within the range of 1/8 to 2 inches. Achieving this mix may require grinding or shredding of raw materials. The action of turning the compost pile will often break up raw materials, such as leaves or grass, sufficiently. In addition, pile mixing can help restore structure and promote natural convection when

materials have compacted over time. Composting with materials whose physical characteristics (i.e., particle size, moisture content and holding capacity) are diverse will enhance the process by optimizing aeration and moisture-holding capacity.

▪ **Temperature.** When proper initial conditions are established, the temperature of the composting material rises rapidly (Figure 3). The temperature must be monitored and the heat released to prevent high temperatures from killing the decomposing microorganisms. This can be achieved by mechanically turning the pile or forcing air through it when the average internal temperature reaches 140°F (60°C). Mixing or aerating a compost pile daily may be necessary initially, but the required frequency will decrease with time. Maintaining temperature above 131°F (55°C) for at least three days will ensure pathogen destruction, and above 145°F (63°C) for three days will kill weed seeds. Primary composting is considered complete when internal temperatures have declined below approximately 105°F (43°C), and remain there even when the compost is aerated and maintained under optimum moisture conditions.

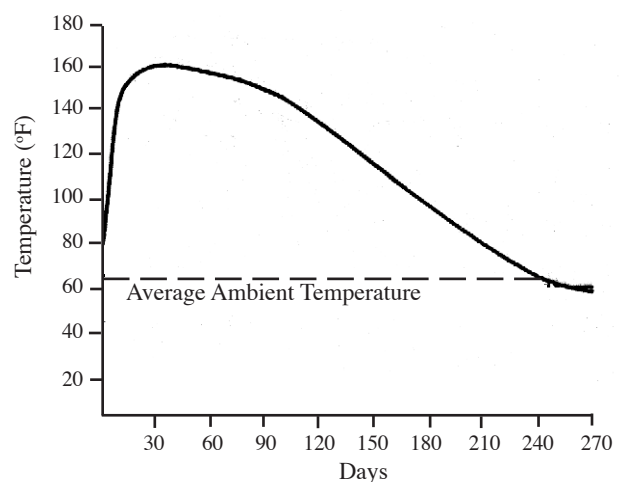

Figure 3. Changes in internal temperature of a composting pile over time. (Dane County Compost Recycling Network, 1988)

▪ **pH.** The acid-base balance can be described by the pH scale. A pH of 7 (on a scale of 1 to 14) is neutral, pH values below 7 are acidic, and pH values above 7 are basic. The pH of compost feedstocks is not critical. Proper composting will result in a pH near neutral (6.5-8.0) for finished compost.

The pH of the composting material can be used as a diagnostic tool. If anaerobic conditions exist for an extended period, the pH will remain low (3 to 6), decomposition rate will slow, and odors will be produced. If low pH conditions occur and persist, reoxygenation of the material can remedy the situation. Correcting for acidic conditions with the addition of lime to the material is not generally necessary or recommended as a high pH will promote the production of ammonia gas. Adding lime may also raise the pH of the end product to a level too high for some plants.

▪ **Inoculants and Other Additions.** Inoculants are marketed as composting rate accelerators. They typically contain bacteria and a medium on which the bacteria can grow. The microbes normally found on organic materials are capable of degrading the material without the addition of commercially available inoculants, if the requirements of proper C:N ratio, moisture and oxygen are met. Finished compost can be added to a newly formed windrow if one desires to provide a concentrated population of

bacteria to the windrows; however, a microbial population will develop readily without such "seeding."

Inorganic nitrogen fertilizer (e.g. urea) is not generally recommended as an additive for low nitrogen materials, such as in the composting of leaves alone. This practice can initially create an appropriate C:N ratio, but this readily-available nitrogen may be quickly transformed to ammonia, a gaseous and odorous form of nitrogen that is easily lost to the atmosphere. A subsequent deficiency of nitrogen may result, and the process may again become limited by nitrogen.

▪ **Curing.** A curing period for achieving compost stability and maturity is an extremely important part of the composting process. Improperly or incompletely composted material that is not stable and mature may contain phytotoxic organic acids or cause soil oxygen depletion and thus result in injury to plants. A curing period allows mesophilic bacteria to recolonize the pile, a more extensive population of macroorganisms to develop, and nitrate-nitrogen (a plant-available compound of nitrogen) to form. Further humus development has been reported to occur more readily during this period, as well.

### C. SUMMARY

A summary of the recommendations for optimum composting is presented in Table 1.

**Table 1. Recommended Conditions For Rapid Composting**

(Adapted with permission from *On-Farm Composting Handbook*, NRAES, 1992)

Condition/Characteristic	Acceptable Range	Optimum Range
Initial carbon to nitrogen ratio (C:N)	20:1 to 40:1	25:1 to 30:1
Temperature	110-150 °F	120-140 °F
Moisture content	40 - 65 %	50 - 60 %
Oxygen concentration	> 5%	>> 5%
Particle size (diam)	1/8 - 1/2	varies with materials, pile size
Initial bulk density	< 1100 lb/yd <sup>3</sup> (40 lb/ft <sup>3</sup> )	—

## II. FEEDSTOCKS

Raw materials are combined to establish the appropriate initial carbon to nitrogen ratio and structure. Table 2 lists the C:N ratio, moisture content and bulk density of common feedstocks for composting on farms. Of course, materials should be analyzed for C and N concentrations, rather than relying on averages. Laboratories that conduct soil, environmental, animal manure and/or specialized compost testing can all provide appropriate analysis for calculating proper mixes of feedstock (See Appendix D).

## A. FEEDSTOCK MATERIALS

▪ **Leaves.** Leaves are a commonly composted material due to the fact that they are usually collected separately by municipalities and can be composted alone or in combination with other organic wastes. Their C:N ratio can range from 40 to 80, making them a good carbon source for on-farm composting with high nitrogen manures. Some disadvantages associated with using leaves in farm composting are that they may contain trash or be compacted and wet when they arrive. Benefits include the fact that

**Table 2. Potential raw materials for farm composting.**

Raw Materials	C:N <sup>†</sup>	Moisture Content (%) <sup>†</sup>	Bulk Density (lb/yd <sup>3</sup> ) <sup>†</sup> __
Bark - hardwoods	116-436		
Bark - softwoods	130-1,285		
Broiler litter	12-1	22-46	650-1,000
Compost <sup>‡</sup>	<17		700-1200
Corn grain	29		
Corn cobs	56-123	9-18	550
Fish wastes	2.6-5.0	50-81	
Food processing wastes	18-50	60-90	
Fruit and vegetable wastes	11-19	60-90	
Grape pomace	28		
Grass clippings	9-25	80	300-800
Hay	15-32	8-10	
Leaves	40-80		200-500
Manure - beef/dairy	13	65-90	1,300-1,600
Manure - horse	22-50	50-80	
Manure - poultry	7	62-75	1,300-1,600
Manure - swine	9-19	65-91	
Newsprint	173-852	3-8	195-242
Paper (domestic waste)	120-180		
Paper mill sludge	54	81	
Peanut hulls	28		
Poultry carcasses	5	65	
Sawdust/shavings	200-750	19-65	350-450
Seaweed	5-27	53	
Sewage sludge (biosolids)	10-15	72-84	1,075-1,750
Silage	38-43	65-70	
Slaughterhouse wastes	2-4		
Spoiled hay	15-32	8-15	
Straw	70-125	4-27	58-378
Wood chips - hardwoods	451-819		445-620
Wood chips - softwoods	212-1,313		445-620

<sup>†</sup> Representative range or typical value

<sup>‡</sup> As additive for raw materials

their carbonaceous components are fairly easily degraded and that some municipalities will pay a tipping fee to farmers accepting them. Frequent temperature-based turning with a mechanical windrow turner will produce a finished compost in the shortest time.

Mixing other organic wastes with leaves permits recycling of these other wastes, accelerates the decomposition of leaves, and creates a nutrient-rich compost. High nitrogen sources that can be composted successfully with leaves include grass clippings or other plant wastes, animal manures, sludges (biosolids), and institutional food wastes.

Composting leaves alone produces a soil amendment with a consistent nutrient content and pH; however, the high C:N ratio of leaves lengthens the time required for full decomposition into compost. Depending on the technology used, composting of leaves alone can take from five months to three years.

▪ **Grass Clippings.** Grass clippings are good complementary materials to add to leaves or other coarse, high carbon compostables, because of their relatively high moisture content (82% average) and low C:N ratio (9-25). A mix of 3:1 (volume to volume) of leaves to grass clippings is generally optimum for rapid composting. Greater proportions of grass clippings promote compaction, which can lead to anaerobic conditions. Grass clippings do have a significant potential for odor generation during collection, stockpiling, and composting.

The composting of leaves and grass requires preparation to accommodate the differences in the collection periods of these two materials through the year. During the early fall, the availability of both leaves and grass allows for ready co-composting. Stockpiled leaves collected in the fall and early winter can be composted with grass clippings collected from the first cuttings through mid-summer.

▪ **Animal Manures.** Animal manures are usually high nitrogen materials that should be mixed with high carbon materials for composting. Establishing an appropriate mix can be difficult because the composition of delivered

material can be variable. Several of the most commonly available manures are described below.

Poultry litter has a high nitrogen concentration (2.5 to 4%), is generally moderately dry (25 to 45%), and should be composted with a high carbon material. It is a very good co-composting amendment when managed to control ammonia generation. Poultry houses are cleaned at varying intervals depending on bird age and house size. Litter haulers may deliver fresh house material or material that has been stored under cover for varying amounts of time. Once litter reaches the composting site, additional considerations, such as length of time before mixing and the amount of precipitation on uncovered material, are important in determining the best mix.

Suitable composting mixtures of high carbon materials such as leaves and poultry litter have ranged from 3.5:1 to 9:1 (volume basis), depending on the moisture and nutrient content of the litter and the age and moisture content of the leaves. A mix of 4 parts leaves to 1 part litter is commonly employed for aged leaves weighing roughly 500 lbs/yd<sup>3</sup> and litter, at 650 lb/yd<sup>3</sup> and a nitrogen concentration of approximately 3%. A ratio as high as 16 :1 (volume basis) may be appropriate for dry, newly collected leaves (~200 lbs/yd<sup>3</sup>) mixed with very fresh, wet turkey litter. Frequent monitoring and timely aeration of piles are essential, regardless of the mix.

Other sources of solid animal manures can also serve as nitrogen sources for composting. Horse manure generally contains large amounts of bedding and, thus, can have a high C:N ratio (30 to 40:1), which often permits the materials to be composted alone. The mix decomposes quickly and has low odor potential when the bedding is straw. Swine and dairy cattle manures are often very wet (~80% moisture content) and have high nitrogen concentrations (up to 4%-dry wt. basis). Unless the manure is collected from bedded pack areas, these materials need to be composted with a high-carbon, dry material. Handling high moisture content manures is difficult, and composting them should be attempted only after previous composting experience. Other livestock manures, such as sheep, goat and rabbit, are also good for composting when they contain

some bedding or are mixed with high-carbon materials.

▪ **Other Yard Wastes and Woody Materials.** Brush trimmings and woodchips are resistant to degradation, but can be excellent bulking agents for other feedstocks. Their large particle size improves air flow in mixes with easily compacted materials or those with initially high moisture content. Some pieces of brush trimmings and woodchips will generally remain after primary composting. Unless these composts are intended as a mulch, they are often screened to remove chips prior to land application or use in potting mixes.

▪ **Other Compostable Solid Wastes.** Many other organic solid waste components can be mixed with yard waste for composting. These include items such as waste paper, unmarketable old newsprint, and food processing wastes. Individual analysis of these highly variable materials is necessary before establishing a composting recipe. Currently, Virginia operations must secure a solid waste composting permit from the Virginia Department of Environmental Quality for composting these wastes.

## B. COMPOST MIXES

Proper compost mixes are based on feedstock C:N ratios, moisture content, bulk density and particle size distribution. The final mix of choice often involves a trade off between C:N ratio and moisture content because the optimum aeration and porosity achieved by adding bulking agents frequently gives higher than optimum C:N ratios. Average C:N ratios (Table 2) are sometimes used in preliminary mix ratio decisions but must not be expected to adequately characterize a material. For instance, generally one loader bucket of grass clippings is appropriate for mixing with 3 buckets of deciduous tree leaves. A smaller volume of compacted, wet leaves may actually be needed because more carbon will be present than in the same volume of dry, loose leaves. On the other hand, a larger quantity of dry leaves may be necessary to provide greater porosity and sufficient available carbon, when mixing with wet, dense grass clippings.

The best approach for determining proper feedstock proportions for a co-composting mix is to

have material analyzed and use the calculations provided in Table 3. Some of the parameters can be evaluated on-farm, but samples must be sent to a qualified laboratory to obtain C and N concentration values. (See Appendix D.)

Material moisture content (%) can be determined on-farm. The feedstock sample should be weighed and then dried at about 160°F (71°C) or less until the dry weight does not change with successive drying attempts.

Example for determining moisture content:

$$\frac{(\text{undried sample wt.}) - (\text{dried sample wt.})}{\text{5 ounces (undried sample wt.)}} \times 100 = 30\%$$

(The general formula for determining moisture content for a mix of materials is provided in Section II of Table 3.)

The calculations in Table 3 yield weight-to-weight ratios of materials. These must be converted using the bulk densities to a volume-to-volume ratio for actual mixing. Some bulk density ranges are reported in Table 2. A sufficiently accurate measurement of bulk density can be determined on-farm by weighing a sample of material in a 5 gallon bucket (the weight of which is already known), subtracting the weight of the bucket, and then multiplying by 40.5 to convert to lb/yd<sup>3</sup>.

$$\text{Example: } 18.5 \text{ lb. broiler litter/5 gal} \times 40.5 \text{ gal/yd}^3 = 749 \text{ lb. broiler litter/yd}^3$$

It is important to try to fill the sample container so that the material is compacted to approximately the same degree expected under composting conditions. Therefore, when sampling, feedstock should not be packed into the container tightly or fluffed up. Determining bulk density for several samples will help establish a range and average.

When a calculated mix based on a desired moisture content of 55% results in a C:N ratio that is too low (<20:1), increasing the amount of dry carbonaceous materials and adding water when constructing the pile(s) will help establish more optimum conditions. Water can also be added at pile establishment if the initial moisture content of a mix formulated for a 30:1 C:N ratio is too low.

**Table 3. Formulas for determining composting recipes.**

(Adapted with permission from *On-Farm Composting Handbook*, NRAES, 1992.)

I. Formulas for an individual ingredient	
Moisture content	= % moisture content ÷ 100
Weight of water	= total weight x moisture content
Dry weight	= total weight - weight of water = total weight x (1 - moisture content)
Nitrogen content	= dry weight x (%N ÷ 100)
% carbon	= %N x C:N ratio
Carbon content	= dry weight x (%C ÷ 100) = N content x C:N ratio
II. General formulas for a mix of materials	
Moisture content	= $\frac{\text{weight of water in ingredient a} + \text{water in b} + \text{water in c} + \dots}{\text{total weight of all ingredients}}$ = $\frac{(a \times m_a) + (b \times m_b) + (c \times m_c) + \dots}{a + b + c + \dots}$
C:N ratio	= $\frac{\text{weight of C in ingredient a} + \text{weight of C in b} + \text{weight of C in c} + \dots}{\text{weight of N in a} + \text{weight of N in b} + \text{weight of N in c} + \dots}$ = $\frac{[\%C_a \times a \times (1 - m_a)] + [\%C_b \times b \times (1 - m_b)] + [\%C_c \times c \times (1 - m_c)] + \dots}{[\%N_a \times a \times (1 - m_a)] + [\%N_b \times b \times (1 - m_b)] + [\%N_c \times c \times (1 - m_c)] + \dots}$
<p>Symbols: a = total weight of ingredient a b = total weight of ingredient b c = total weight of ingredient c m<sub>a</sub>, m<sub>b</sub>, m<sub>c</sub>, ... = moisture content of ingredients a, b, c, ... %N<sub>a</sub>, N<sub>b</sub>, N<sub>c</sub>, ... = % nitrogen of ingredients a, b, c, ... (% of dry weight) %C<sub>a</sub>, C<sub>b</sub>, C<sub>c</sub>, ... = % carbon of ingredients a, b, c, ... (% of dry weight)</p>	
III. Shortcut formulas for only two ingredients	
<p>1. Required amount of ingredient a per pound of b based on desired moisture content:  <math display="block">a = (m_b - M) / (M - m_a)</math>                     Then check the C:N ratio using the general formula.</p> <p>2. Required amount of ingredient a per pound of b based on the desired C:N ratio:  <math display="block">a = \frac{\%N_b}{\%N_a} \times \frac{(R - R_b)}{(R_a - R)} \times \frac{(1 - m_b)}{(1 - m_a)}</math>                     Then check the moisture content using the general formula</p>	
<p>Symbols: a = pounds of ingredient a per pound of ingredient b M = desired mix moisture content m<sub>a</sub> = moisture content of ingredient a (e.g., woodchips) m<sub>b</sub> = moisture content of ingredient b (e.g., manure) R = desired C:N ratio of the mix R<sub>a</sub> = C:N ratio of ingredient a R<sub>b</sub> = C:N ratio of ingredient b</p>	

### III. SYSTEMS

#### A. WINDROW

On-farm composting is most often conducted by building composting windrows - elongated piles typically 4 to 9 feet tall, 10 to 18 feet wide, and as long as needed for the volume of material to be composted. Mechanical mixing and aeration are accomplished with a) a front-end or skid loader; b) a backhoe; c) a tractor with bucket; d) a tractor with manure spreader; e) a tractor-pulled windrow turner; or f) a self-propelled windrow turner.

Windrows can be constructed with a front-end loader (or similar equipment), tractor with manure spreader (Figure 4), or a dump truck (Figure 5). An effective way to construct a windrow with a front-end loader or tractor with a bucket is to spread a layer of high carbon materials on the windrow site in the desired width and length; follow this with a layer of high nitrogen materials; and then add another layer of carbon materials. Several layers can be applied to minimize initial mixing. The windrow is then mixed as thoroughly as possible with the bucket by repeatedly lifting and slowly letting the material tumble out.

The lifting and tumbling method is also employed when using a bucket for windrow turning/mixing during processing. Care should be taken to avoid traveling into the windrow and compacting materials. A tractor and manure spreader can also be used with a loader (or similar equipment) for windrow mixing. If a windrow turner is to be used for processing, windrows must be constructed to accommodate the height and width dimensions of the turner or additional time will be required for windrow modification.

Some operators suggest that the minimal equipment requirements for turned windrow composting of about 3,000 cubic yards of material are: a) a 50 to 90 hp tractor with as large a loader-bucket as possible, or a skid loader; b) a 60 to 80 hp tractor with PTO and creeper gear, capable of pulling a manure spreader at slower than 1 mph; and c) a PTO-driven manure spreader, preferably with low-speed setting (apron-chain, beater-type, single axle). Other on-farm composters have been successful without a manure

spreader. A windrow turner provides most efficient processing. These can range in price from roughly \$15,000 for a tractor-pulled type to about \$25,000 for farm-scale, self-propelled models. Tractor-pulled windrow turners generally must be pulled by a tractor capable of very low speeds of as little as 1/2 mph.

Breathable compost covers, generally made of geotextile fabric, are used by some farmers as an effective means of preventing excess precipitation from over-wetting the piles. If windrows are left exposed to precipitation, more frequent mixing is often necessary to control moisture content and prevent anaerobic conditions. Compost covers come in rolls of various widths and lengths, and are made of materials that allow air exchange. Although they are expensive (approximately \$0.25/ft<sup>2</sup>, \$3/running ft.), their cost should be evaluated against the extra time, labor and equipment usage necessary to control moisture content without them.

#### B. AERATED STATIC PILE

▪ **System Description.** Another method for on-farm composting involves using a system of pipes and blowers to aerate elongated stationary piles (up to 80 ft. long) (See Figure 6). A pile should be no more than 8 feet tall including a 6-inch covering of finished compost or bulking agent, such as a mixture of soil and sawdust or leaves. This additional covering serves as a filter for potentially odorous gases and serves as an insulating barrier against heat loss. The piles are typically constructed over a 6- to 12-inch deep porous base material, such as woodchips, within which a perforated aeration pipe (4 to 8 in. diameter) has been laid. The porous base should not extend out to the edge of the pile, but should range from 1/4 to 1/3 of the pile width and reach to no closer than 8 feet from the end of the pile. The perforated aeration pipe is connected to a blower operated on a time schedule (4-inch pipe diam.) or with temperature-based control (6-8 inch pipe diam.), and designed to either pull or force air through the pile at a recommended maximum velocity of 2000 ft/min. Air flow rates range from 15-25 ft<sup>3</sup>/min (time-based control) to 100 ft<sup>3</sup>/min (temperature-based control) per dry ton of material.

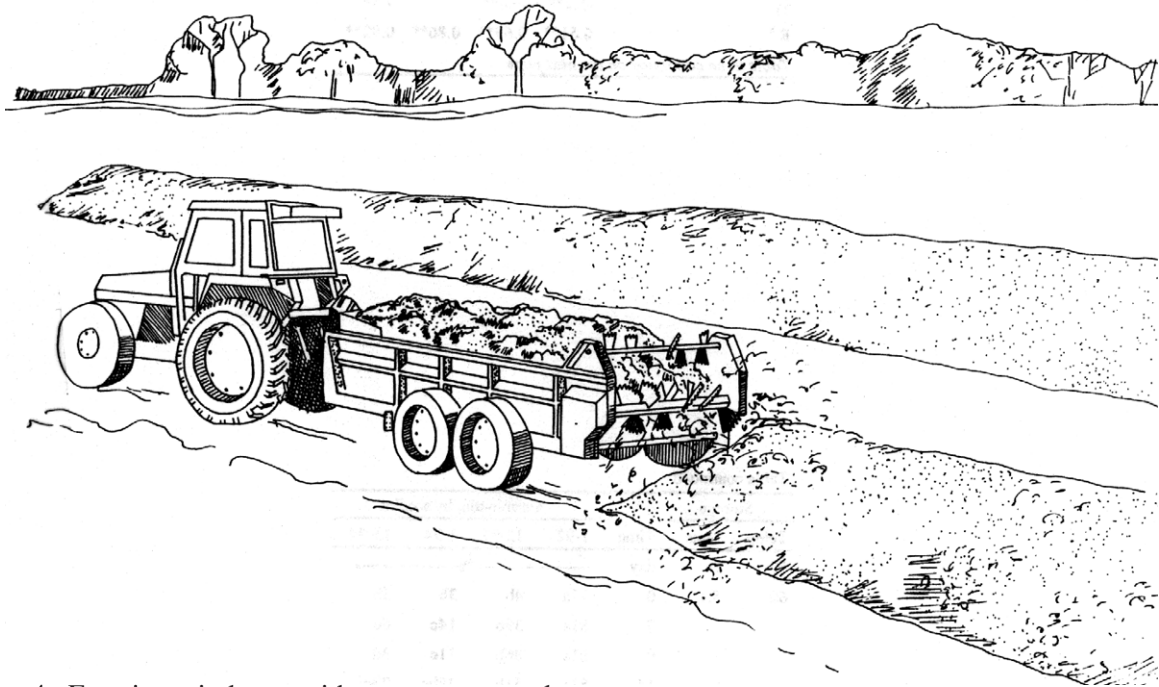

Figure 4. Forming windrows with a manure spreader.  
(Reprinted with permission from *On-Farm Composting Handbook*, NRAES, 1992.)

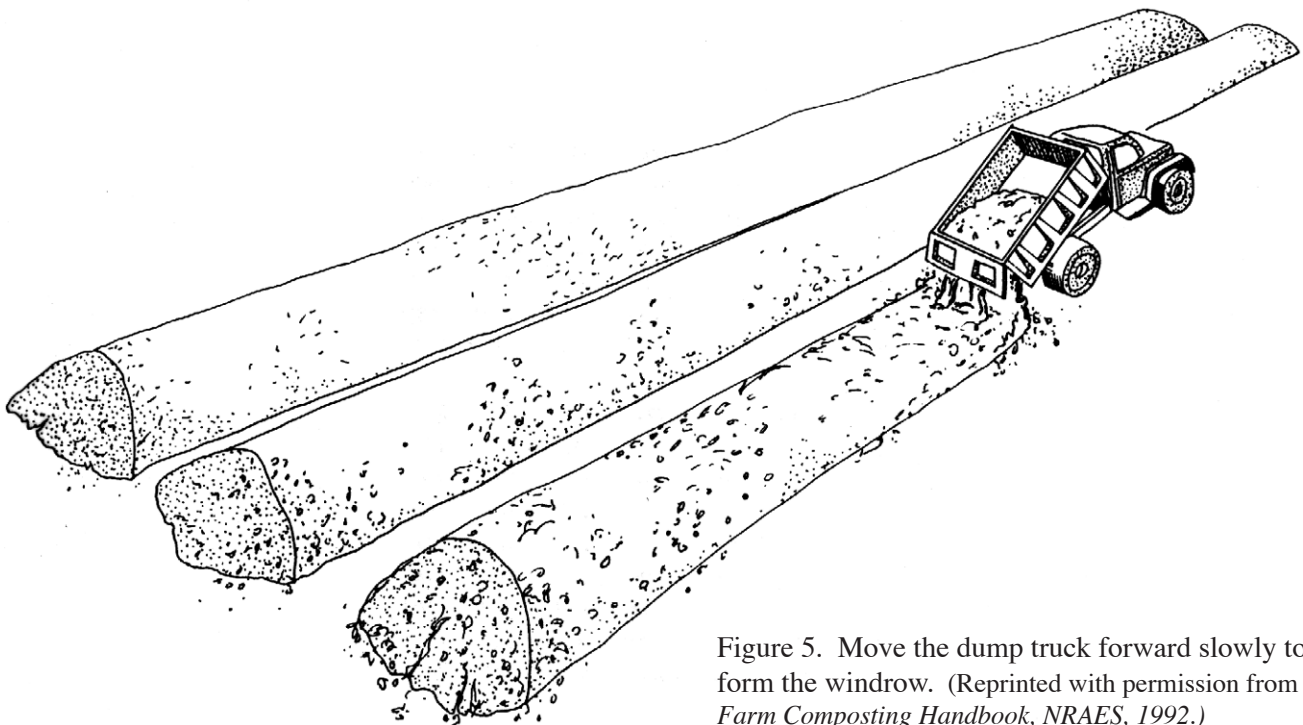

Figure 5. Move the dump truck forward slowly to form the windrow. (Reprinted with permission from *On-Farm Composting Handbook*, NRAES, 1992.)



▪ **Pipe Sizing/Air Flow.** Pipe hole size and spacing can vary depending on pipe size and length. The general formula for determining hole diameter is:  $\sqrt{[(D^2 \times S)/(L \times 12)]}$

(where: D=pipe diameter (inches); L=pipe length (ft.), and S=hole spacing (inches).)

Air flow rate and pipe specifications are determined according to Table 4.

▪ **Blower System.** Basing blower control on temperature is more expensive than using a simple time schedule, because it requires a larger blower (3 to 5 hp vs 1/3 to 1/2 hp) with more air-flow, a larger aeration pipe, and a more sophisticated control system. Temperature set-point is generally about 122 - 130°F (50-54°C). Continuous low flow blower operation is also possible, but because predominant air channels develop, there is less even air distribution throughout the pile. A suction system (pulling air) generally requires a condensate trap (inexpensive) and an odor filter, which can be a pile of screened compost. Although these components necessitate a larger blower, this system controls odors much more effectively than a pressure system (pushing air). Controlling any undesirable odors occurring with a pressure system is often addressed by increasing the outer cover depth.

▪ **Construction and Operation.** Thorough initial mixing of materials and proper particle size are critical for establishing sufficient and well-distributed air flow throughout the composting process, because no physical mixing or turning takes place after pile construction. Initial mixing can be accomplished with a manure spreader, batch type feed mixer, or pug mill. Extra care must also be taken with this type of process in order to ensure protection of the aeration pipe.

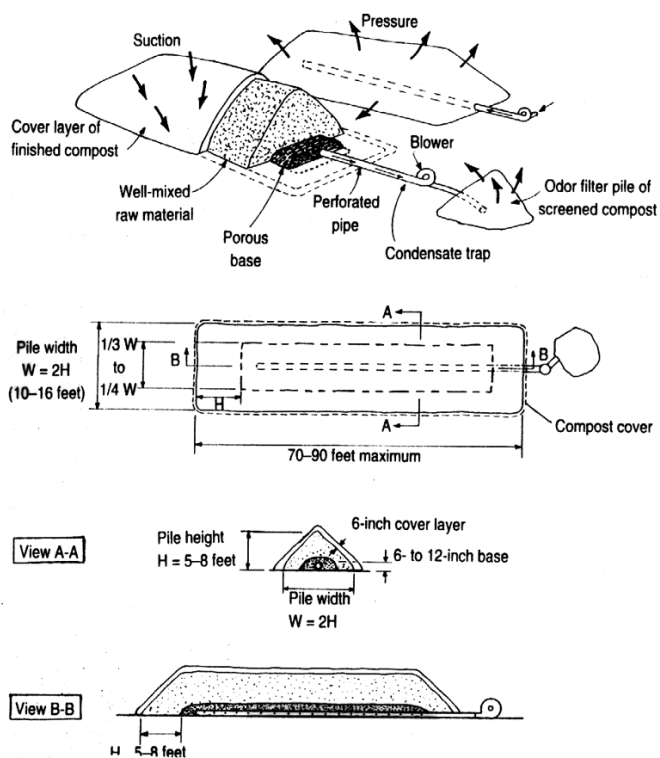

Figure 6. Aerated static pile layout and dimensions. (Reprinted mission from *On-Farm Composting Handbook*, NRAES, 1992.)

The operation site must also be equipped to provide electrical power. The pile can be built in sections, and new feedstock can be deposited in place of finished material removed for curing. Screening of the end-product is generally required with static pile systems in order to separate the base and cover material (when the latter is not finished compost) from the finished compost.

▪ **System Costs.** Aerated static pile composting may be more attractive to operators who cannot afford the capital expense of a windrow

**Table 4. Air flow rate and pipe specifications** (NRAES, 1992).

a) air flow (total ft<sup>3</sup>/min) = \_\_ dry tons of material x \_\_ft<sup>3</sup>/min./dry ton

[15-25 ft<sup>3</sup>/min for time-based control; 100 ft<sup>3</sup>/min for temperature-based control]

b) pipe area (in<sup>2</sup>) = [(\_\_ total ft<sup>3</sup>/min) / (2,000 ft/min max.velocity)] x 144 in<sup>2</sup>/ft<sup>2</sup>

c) diameter (in) =  $\sqrt{[(\_\text{in}^2 \times 4)/\pi]}$  ( $\pi=3.1416$ ; round result up to nearest available pipe size)

turner. Blower and piping costs to set up a system to process up to 100 yd<sup>3</sup> of cattle holding lot bedding were approximately \$2,000 in central Virginia in 1996. The largest expenses were the purchase of a blower and electrical system installation. Costs can be lower than with a turned windrow system, because processing time is much shorter (3 to 5 weeks) and less land area is necessary. The cost of screening the final material must also be considered. Screening units capable of processing from 25 to 50 yd<sup>3</sup> per hour range in price from \$35,000 to \$100,000.

### **C. PASSIVELY AERATED WINDROW**

This system also does not involve turning the windrows once they are constructed. Generally, a 6- to 9-inch base of straw, finished compost, or material such as peat moss is first laid on the ground surface. Sections of 4-inch diameter perforated pipe, approximately 14 feet long, are laid on top of the base perpendicular to the length of the windrow, at 18-inch to 3-foot intervals. Septic system drain field pipe (schedule 40 PVC) with 2 rows of half-inch diameter holes running the length is often used. Some operations lay the pipe sections on the ground surface and cover them with 6 to 8 inches of wood chips. A windrow approximately 10 feet wide and 3 to 4 feet tall is constructed over top of the pipes and covered with a 6- to 8-inch layer of compost or peat moss, with or without a breathable fabric. Other windrow dimensions are also possible, and wider windrows will better accommodate the 20-foot length pipes generally available, avoiding cutting costs. In all cases, however, the covering layer is necessary for insulation and odor control. The open-ended pipes will extend out from the windrow on both sides and draw air into the pile as natural convection creates a chimney effect. It is very important to choose materials that have a wide range of particle sizes and to thoroughly mix the raw materials before building the windrow. Good porosity and structure are far more critical in this system than in those that are actively aerated. Approximately 19,000 ft<sup>2</sup> would be required to establish ten windrows that are 3.5 feet tall, 10 feet wide, and 75 feet long for composting a total of 500 yd<sup>3</sup> of material.

## **IV. PROCESSING AND QUALITY GUIDELINES**

### **A. PROCESS MANAGEMENT**

The four most important tools for compost process monitoring and management are: a thermometer, one's hands, one's eyes, and one's nose. Additional monitoring equipment enhances process management but cannot replace these. Monitoring and management of the process on a regular and even daily (during the first several weeks) basis will allow an operator to maintain optimum composting conditions and avoid surprises, such as the development of odors offensive to neighbors. Under optimum process management a compost pile requires attention when average temperatures fall outside the optimum range of 100-140°F (38-60°C) or moisture content is too low (<45%) or too high (>65%). After some experience, a normal pattern in the profile of the temperature and changes in the composting material can be observed over time, and an operator will develop an invaluable sense of the process. A form similar to that in Appendix A can be used to record process information. Records can provide useful information for increasing efficiency by keeping track of successes and problems.

### **B. TROUBLESHOOTING**

The most common problems that occur in composting are those related to odor generation and decomposition rate. There are many interrelated variables that affect the process and contribute to these problems. For instance, when the temperature inside the pile does not increase to between 110 and 140°F (43 to 60°C) within a day or so of pile construction, one of the following may be the cause: a) the C:N ratio is too high; b) too little moisture is present; or c) too much moisture and insufficient oxygen are present. Correcting problems is often a trial and error process. A concise, thorough tool for troubleshooting is presented in Appendix B.

### **C. WATER QUALITY PROTECTION**

The composting site should be designed to divert surface water and to control runoff to protect nearby surface waters. Site design must maintain all-weather conditions for equipment travel. The establishment of a grass filter strip

below the composting area provides an inexpensive method to manage runoff. The strip should extend across the full length of the site and be of sufficient width to capture the highest rainfall expected in a 24 hour period. This width will depend on the slope. Proper filter strip size is also dependent on soil type and grass cover species. Fescue and reed canary are often recommended. Your Agricultural Extension agent or Natural Resource Conservation Service personnel can assist in filter strip sizing. In order to avoid compaction and to maintain high infiltration rates, heavy equipment should never travel over the strip. Filter strip maintenance is also important. Sediment build-up can cause water to pond behind the strip.

#### **D. CURING AND STORAGE**

Generally, when the interior temperatures have stabilized at or below approximately 105°F (43°C) under proper moisture and aeration conditions, then primary decomposition is considered complete and the compost is ready for a curing period. A curing period of one to several months is necessary before using the compost in order to ensure material stability and maturity. Curing is considered complete when internal temperatures decline (under proper moisture and oxygen conditions) to near ambient.

Curing piles can be larger than windrows and of any shape, but must not be so large as to promote anaerobic conditions. Periodic mixing is highly recommended for material that is stockpiled for several months.

#### **E. COMPOST QUALITY CONSIDERATIONS**

Ensuring finished compost quality is as important as maintaining optimum conditions during the process. Physical, chemical and biological characteristics are used to assess compost quality. The material should be free of foreign materials, such as plastic bag remnants and other trash. It should also be stable and mature, and have concentrations of soluble salts and heavy metals below acceptable limits. Composters should be aware that some composts can contain high concentrations of soluble salts which inhibit plant growth and are not remedied by the cur-

ing process. Having the final material analyzed for these and other parameters is important to ensure that the compost is not used inappropriately, or that it is amended as necessary prior to use. Table 5 provides guidelines for several compost quality parameters.

Immature or unstable compost can have negative effects on soil and plant life. The curing period following active decomposition helps to ensure compost stability and maturity. A stable compost does not reheat upon turning/aeration when proper conditions are maintained, and a mature compost will not injure plants.

There are both field and laboratory methods for determining compost stability and maturity. The least costly means of determining stability is to measure temperature response to turning/aerating in the field. It is advisable to conduct this test several times once the temperature has stabilized while making sure optimum conditions exist. Alternatively, there are devices that test a composite compost sample and can be utilized to determine stability within just a few days. One of these involves measuring temperature rise in a properly moistened sample incubated in a small, well-insulated vessel for five to seven days. The degree to which the temperature rises as compared to an established scale determines the degree of stability. Information on these devices can be obtained through the resource individuals listed in Appendix D. Laboratory methods for determining the stability of a compost include measuring the generation of carbon dioxide or consumption of oxygen to reveal the activity level of the microbial population. The most common method for determining if a compost is mature is by conducting a simple seed germination test, often with radish seeds.

**Table 5. Compost Quality Guidelines.** †

Characteristic	Potting Media Amendment Grade	Top Dressing Grade	Soil Amendment Grade
recommended uses	formulating growing media for potted crops	top dressing turf	agricultural soil improvement; establishment/maintenance of landscape plantings; disturbed soils restoration
particle size	<1/2 inch	<1/2inch	<1/2 inch (larger sizes suitable for disturbed soil restoration)
pH	5.0 - 7.2	5.5 - 8.0	range should be identified
soluble salts (mmhos/cm)	< 4	< 5	< 20
respiration rate			
O <sub>2</sub> =mg/kg·hr	< 200 (O <sub>2</sub> )	< 200 (O <sub>2</sub> )	< 400 (O <sub>2</sub> )
CO <sub>2</sub> =mg/g·day	≤ 5 (CO <sub>2</sub> )	≤ 5 (CO <sub>2</sub> )	≤ 10 (CO <sub>2</sub> )
trace elements/ heavy metals	not to exceed EPA standards for unrestricted use (Part 503 Reg.)		

† Adapted from: a) NRAES, 1992; b) E&A Environmental Consultants, Inc., 1995; and c) Alexander, R.A. 1995.

## V. APPLICATION AND BENEFITS

Compost can improve the biological, physical and chemical properties of soils and growing media. Vast quantities of microorganisms are introduced with compost, helping to promote humus formation and increase the availability of plant nutrients. Plant diseases, such as pythium and fusarium, as well as nematodes can be suppressed by certain of the beneficial microorganisms present in composts (Grebus *et.al.*, 1994; Logsdon, 1995; Hoitink *et.al.*, 1993; The Composting Council, 1996). Composts also encourage macroorganisms, such as earthworms, which improve soil aeration.

High quality composts improve the physical structure of soils and potting media by improving aggregation, reducing bulk density, and increasing water-holding capacity as well as permeability. These improvements result in greater resistance to compaction and erosion and potential reductions in required irrigation water.

Another major benefit to soil/growing media provided by compost is through the addition of

organic matter, which buffers (stabilizes) pH, increases cation exchange capacity (better plant nutrient retention), and supplies plant macro- and micronutrients, such as nitrogen, phosphorus, potassium, calcium, magnesium, manganese, boron, and iron. Utilizing composts as a sole alternative to conventional fertilization is not often feasible, however, because these nutrients are not typically present in concentrations (weight to weight basis) comparable to most commercial fertilizers, thus necessitating large volumes of compost. In addition, many of the nutrients are tied up in slowly plant-available organic forms. Nonetheless, reductions in commercial fertilizer use and more efficient fertilizer utilization by plants have been well reported, as have increases in crop yields and improvements in growth of turfgrass and in nursery and greenhouse stock.

The Composting Council, a national trade organization representing the composting industry, has established recommended application rates. Some of these are shown in Table 6.

**Table 6. General Uses and Application Rates for Compost** (Composting Council, 1994).

Market	Applications	Approximate Usage Rates
Landscapers	new turf establishment turf renovation planting bed preparation mulching backfill for tree planting outdoor planter mix	1-2" tilled to a 5" depth depending on soil type 1/8"-1/2" topdressed after aeration 1-2" tilled into raised beds 2-3" around all landscape plants 30% of planting hole volume 20-40% by volume
Nurseries	field application as a soil amendment band application for shade trees liner beds - incorporated liner beds - mulched container mixes	1-2" incorporated 5" deep 2" applied in 2-foot wide band 1-2" incorporated pre-plant to 5" depth 1-2" mulched post-plant 5-40% of vol. depending on plants
Agriculture	general field soil amendment specialty crop production	1-2" incorporated to 5-8" depth 1-2" incorporated to 5-8" depth
Retailers/ Homeowners	common landscape or garden amendment mulching	1" application or 20% of planting mix 2-3" around all landscape plants
Topsoil blenders	soil amendment for many beds	10-50% for blends depending on plant family and specifications
Silviculture	new seedling establishment mulch	1-2" disked where possible 1-2" evenly applied

## VI. PLANNING AND SITING

Establishing and managing a successful composting operation requires meeting a series of objectives concerning planning, assessing the economics, and siting of an operation. Many of the factors important in planning interact, and decisions are often influenced by multiple factors. The following steps provide a simplified approach to the planning process.

### A. IDENTIFY GOALS

Develop your composting plan based on a clearly defined set of goals. Examples of goals are: a) to produce a valuable soil amendment or potting medium for on-site use; b) to improve livestock manure management; and c) to increase farm economic potential through the sale of compost. Regularly revisiting goals will permit timely changes that might be necessary in order to maintain an efficient composting operation.

### B. UNDERSTAND THE COMPOSTING PROCESS

Basic knowledge of the composting process is essential for making planning decisions. It is beneficial to consult many sources for information on composting principles and systems, feedstocks, and process management. A list of other publications and resources is provided in Appendix D. Visit existing compost operations to learn about the practical aspects of composting (i.e., facility design and siting, equipment operation, troubleshooting the process, and achieving desired finished material quality). Valuable information can be gained through the experiences of other composters who can be identified through the *Virginia Organics Recycling & Composting Directory* (VCE Pub.452-230) or by contacting your Cooperative Extension agent and/or the Virginia Recycling Association's Organics Recycling and Composting Committee (see Appendix D.). Internet resources are also important sources of information. Some of these are also listed in Appendix D.

### C. ASSESS FEEDSTOCK AVAILABILITY

Most organic wastes can be composted, but materials that provide a balanced C:N ratio and achieve desired particle size distribution may not be easily obtained. Locating numer-

ous sources of feedstock materials can improve the overall dependability of materials flow and allow flexibility in determining mixes. State agency representatives such as your local Extension agent can be helpful in identifying waste streams that are not readily apparent.

Some materials may be available free of charge (e.g. municipal leaves, sawdust), while in other cases, waste handlers may be willing to pay a tipping fee to deposit materials on farm. Some feedstocks may need to be purchased, such as poultry litter, which can provide nitrogen for the farm composting operation with an overabundance of high carbon content materials. The costs should be well researched and appropriate arrangements made for delivery. Obtaining a contract for materials delivery is recommended; therefore, assessing the potential for such contracts is important in the planning process. Issues important in developing a materials delivery and management contract are presented in Appendix C. Any such contract should address: length of agreement, quantity, fees (if any), delivery schedule and conditions, quality, contingencies, and assignment of responsibility in the event of damages. Securing the services of a competent legal advisor is recommended.

Delivery mode and quality of materials are critical issues. Many waste streams can contain nuisance and even hazardous materials. Glass, metals and plastics can excessively contaminate municipal leaves collected with a vacuum truck. Some of these can damage equipment or impede mixing and processing, and can potentially become projectiles thrown by windrow turners. Variations in moisture content and nitrogen concentration may require using differing amounts of individual materials. In addition, processing raw materials prior to composting is sometimes necessary. Being aware of these factors can help one negotiate a workable contract.

### D. DETERMINE SITE SUITABILITY

Sites should be evaluated based on the planned and potential amount of wastes to be composted, accessibility, the existence of or potential for creating an appropriate surface, proximity to a water source for wetting windrows or piles, and regulatory requirements for set-backs and water quality protection. Specifically, Virginia

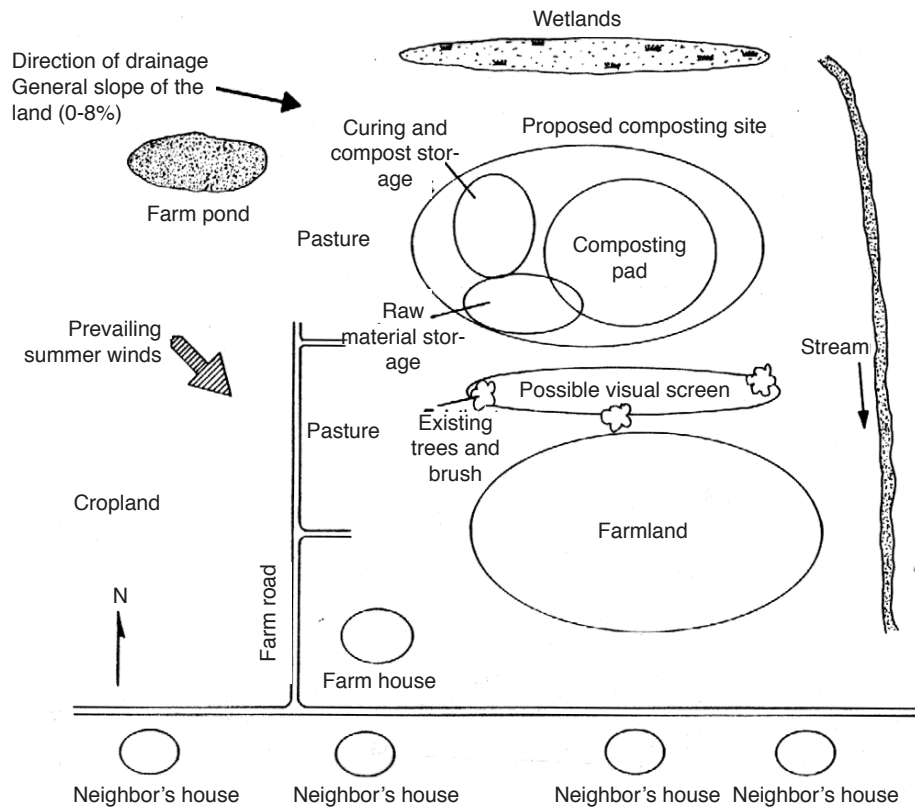

Figure 7. Compost operation site.

(Reprinted with permission from *On-Farm Composting Handbook*, NRAES, 1992.)

yard waste composting regulations require that the composting area not be within a designated flood plain and that it be at least 24 inches above the seasonal high water table.

The composting site must be large enough to allow for receiving and handling of all feedstocks, for composting and curing, and for equipment operation. The various systems used in farm composting are presented in Section III. Site sizing should also take into account the possibility of some event preventing the composting of the incoming material, as well as potential delays in moving the cured compost off-site (Figure 7 shows a sample facility layout). Approximately 1.2 acres will be required for active composting and curing of 1,000 yd<sup>3</sup> of material processed in four windrows 100 yds. long, 4.5 ft. tall and 10 ft. wide. This includes space for material receiving, composting, equipment maneuvering, compost curing, and a grass filter strip. This same area would be adequate to compost 4,000 to 6,000 yd<sup>3</sup> annually, if feedstock delivery is spread over several months and rapid composting is practiced. An area of approximately 0.9 acre is needed for aerated static pile composting of 1000 yd<sup>3</sup> of material in 10 piles that are 12 ft (w) x 6 ft (h) x 75 ft

(l) and covered with an additional 6-inch insulating/filter layer. This includes space for material receiving, cover material stockpiling, composting, blower pad, compost curing, and a grass filter strip. State regulations require certain setbacks or buffer zones concerning proximity to neighbors. These are addressed in Section VII.

Composting can be conducted on the existing ground surface, on some type of ground covering material (such as woodchips), or on a prepared surface over compacted subsoil (such as a base of mixed rock plus rock dust, or a paved area). An area with moderate to well-drained soils is desirable for composting on existing ground surface. A prepared surface minimizes the development of ruts and ponding during rainy weather, requires less maintenance, and prevents the inadvertent incorporation of soil or loose surface material for turned windrow composting. For turned windrow composting, a grade of 2-4% (4 ft. drop over a 100 ft. length) will permit runoff to drain adequately and will prevent excessive erosion when composting on a non-paved surface. The expense of grading will vary widely from site to site.

Composting generally produces little leachate unless uncovered windrows or piles are exposed to heavy rains. Properly designed grass filter strips will trap runoff and prevent surface water contamination. Proper filter strip size is dependent on soil type and grass cover species. Local Extension agents, Natural Resource Conservation Service personnel, or other agriculture agencies can assist in filter strip sizing.

## E. ASSESS PROJECTED OPERATION ECONOMICS

The addition of a composting operation to a current agricultural enterprise is not simply a matter of adding a piece of equipment or one new task for a worker. Composting can require substantial investments of capital, labor, land, and management resources. A reduction in current activities or the addition of new personnel may be necessary. Management of a composting operation may require daily attention during certain phases of the process. Depending upon the scale of the planned composting operation, the initial investment could range from a few hundred to tens of thousands of dollars. Key economic variables to consider include:

- benefits of using compost on farm, such as increased yields, reduced fertilizer or other input cost;
- income potential from selling finished compost;
- cost of any additional labor if needed;
- credit availability and cost, if additional investment is needed;
- operating cost and purchase of equipment and facilities, if needed.

A business plan should be developed for any new farm enterprise, including financing, operation and investment costs, and projected income. However, a series of questions should be answered before ‘penciling out the numbers.’

- What quantity of suitable organic material is available, and at what price? Is a large quantity of high-nitrogen material such as animal manure produced on farm that requires disposal in any case, or is manure available at low cost? What quantities of carbon sources are available, and at what price, if any? Might a municipality or business pay for a farm to receive compostable organic wastes? What are the transportation

costs, if any, in bringing feedstocks to a composting site?

- Does the land area have easy access, adequate drainage, and suitable slope? Is it reasonable to sacrifice whatever net return is currently derived from this land in order to dedicate it to compost production? If only a little land is available relative to the amount of compost that will be produced, is it reasonable to consider a more capital-intensive (and expensive) production system? How much will it cost to prepare the site for compost production, and to prepare entry and exit for delivery and sales?
- How much labor and management time will be required for compost production and marketing? At what times of the year will raw materials be available and do these coincide with targeted compost production periods? At what times of year will compost marketing, loading or delivery efforts be possible or necessary and will product availability coincide with demand? Will compost demand occur at the busiest time of \_\_\_\_\_ year for farming operations? Is it possible \_\_\_\_\_ and more advisable to put in more labor time as opposed to purchasing more equipment?
- What production system and level of technology would be best to use, and what are the capital investments needed? Can some existing farm machinery be used efficiently? Are large capital investments affordable, or is it better to choose a simpler, smaller production system?
- How much do government permits cost, and what are the restrictions applicable to on-farm composting that affect cost?
- Is it reasonable to risk money, time, and effort on this venture? Would the failure of a composting operation put this farm into financial jeopardy?

In order to derive economic benefit, the end-use value (whether it is in increased yields, reduced off-farm fertilizer and pesticide inputs, reduction in irrigation requirements for crop production, or in sales of finished compost) must exceed the



sum of lost revenue from land use changes plus the costs for compost production and marketing/utilization. Refer to Sections II and III for a discussion of feedstocks and the various equipment and systems options available. A process for developing a budget is presented in Section VI.I. Keep in mind, however, that not all costs are quantifiable. For instance, long-term improvements in soil quality are not readily translated into dollar figures on a balance sheet.

Anticipating production costs can be difficult because they have been minimally reported and vary widely. Expenses are very dependent on the quantities, types and characteristics of the incoming material, the production system employed, and the equipment being used. (Refer to Section VI.I for some reported costs.)

In windrow composting, the cost of *passive* composting principally involves loss of the land to other uses and the initial investment in perforated aeration pipes. However, when using existing farm equipment to *actively manage* composting windrows, the costs additionally include greater site development and maintenance, labor not available for other activities, and increases in equipment use, maintenance/repair, and rate of depreciation. Utilizing a windrow turner can dramatically increase processing capacity (500-2,000 yd<sup>3</sup>/hr with a turner vs. approximately 50 yd<sup>3</sup>/hr with a tractor and bucket), and thus reduce labor costs per yd<sup>3</sup>, while increasing efficiency, and improving end-product quality. The cost to purchase and own such equipment, however, can represent considerable expense.

For on-farm static pile aerated systems, set-up costs include site preparation, electrical service installation, and blower and piping costs. Operating costs will vary greatly based on such things as the types of wastes, how well they are initially mixed, and the blower control schedule.

## **F. ASSESS THE MARKET POTENTIAL IF COMPOST IS TO BE SOLD**

Market research is an essential part of any business venture (German, *et al.*1994). The first step towards assessing market potential is to determine the cost of the potential product. A market potential exists when it can be determined that customers have a need for the product and a

consistent, high quality product can be supplied at a competitive price. An important marketing message is that compost produces higher benefits per dollar purchased than competing products, is locally produced, and is environmentally desirable. If many potential customers already accept this message, ready markets may be available.

The three most important factors in marketing are location, location, and location. Is the composting site close enough to urban and suburban markets to avoid ruinous transportation costs for the finished material? Do special location advantages exist for establishing long-term agreements with clients? Does a compost market currently exist, or must it be created? Organic farmers, greenhouse operations, and landscape businesses will likely be valuable customers, since each has significant soil amendment needs. Local Extension agents or appropriate farmer organizations can assist in estimating the size of the potential market and facilitating contacts with customers. Greenhouse operations and landscape businesses should be contacted directly. Having product samples available to distribute and being willing to offer a low introductory price for initial purchases can enhance sale opportunities. Other possible clients are nursery businesses, golf courses, municipalities and other government bodies. A large potential for new clients is among homeowners, although they must be educated about the benefits of using compost as an alternative or addition to traditional soil amendments or landscape mulches. A market advantage can be gained by offering custom compost blends using different composts, woodchips, and/or topsoils. Landscapers may want a coarse material (i.e. with some chips) to utilize as mulch; gardeners may be seeking very fine material; and homeowners, a compost/topsoil blend for flower beds. Investigating the specific needs of different customers will allow development of application-appropriate blends.

Target markets may initially depend on existing delivery and distribution systems. Direct bulk sales at the farm has been the most common avenue for young operations. Selling bulk compost through retailers such as garden shops is an option for those with the capacity to deliver the material economically. Small or medium volume compost producers generally cannot

justify a bagging operation to sell compost in 25- or 40-pound bags, but this avenue can become attractive as an operation grows. In some cases, composters have found retail nursery operations willing to cooperatively purchase a bagging machine for customer self-service use.

Even if no clear market exists for compost, there may be opportunities to educate potential customers and increase demand. Such an effort will require generating the advertising creativity, putting in the time, and incurring the costs of customer education. Customers first must know a compost production business exists in their area in order for them to seek out the product. They also need information about the product. Distributing product samples, writing articles for local magazines, buying local radio spots or newspaper ads, and giving presentations to garden clubs or Master Gardener meetings are all possible avenues for building a market.

### **G. INVESTIGATE LOCAL AND STATE REGULATORY REQUIREMENTS**

Understanding regulations is essential for compliance. Local ordinance restrictions must be investigated thoroughly, not only to ensure compliance, but to maintain cordial relations with neighbors who may not initially consider a composting operation an asset for the community. Restrictions may include such things as maximum truck weights on roads leading to the farm and set-backs or buffer zones for particular agricultural practices. In addition, because composting may not explicitly fall within the definition of existing controlled activities, planning commissions or other local governing boards may need to be consulted and petitions for changes to local ordinances may be necessary. Section VII gives a detailed treatment of the Virginia state composting regulations affecting agricultural operations.

### **H. SELECT TECHNOLOGY LEVEL AND ESTABLISH OPERATION SIZE**

Composters may choose among active windrow composting, passive windrow composting, and aerated static pile composting as the technology to adopt. A discussion of these is provided in Section III.

## **I. DEVELOP OPERATION BUDGET**

A business plan, including an annual projected cash budget, should be constructed, if a composting operation appears feasible and desirable. Remember that the cost of compost production and the net revenue earned (if compost is sold) are very farm-dependent, subject to the production system and equipment needs, the materials used for composting, the distance the farm lies from available markets, and a host of other factors.

To develop a composting budget, make realistic estimates of ALL the anticipated costs of the operation, and don't become starry-eyed about the revenue potential. No one wants to have unwelcome 'surprises' about costs or returns. The costs and returns should be 'penciled out' to be sure that compost production costs will be below an acceptable level, and (if sold) that the compost will earn a solid return. Area Extension Farm Management agents can be contacted for assistance. Such a budget can be organized as follows:

- **Cost: Materials and supplies.** For materials imported to the farm, the costs for purchase, transport, and other inputs associated with delivery to the composting site should be included. When using one's own equipment, a hauling cost which reflects all the costs of fuel, oil, maintenance and repairs, equipment taxes and depreciation should be included. As a rule of thumb, budgeting less than \$0.10 per ton per loaded mile may be underestimating hauling costs.
- **Nitrogen sources:** These costs should include the total annual cost of organic material sources such as animal manure. If purchased from off the farm, include purchase, transport, and any other costs for delivery to the composting site. If manure is normally produced and spread on the farm, there may be no additional costs with composting.
- **Carbon sources:** The costs of materials and supplies should also include total annual cost of high-carbon materials, which usually are not produced on the farm. The most attractive high-carbon material for many farmers is yard waste that is provided, in some cases, at a subsidy (tipping fee) from

local municipalities. Consider a tipping fee as a revenue or (equivalently) a 'negative cost.' Other materials include paper and some wood products, crop residues, hay or straw, and seaweed or aquatic plants (see Table 2).

- ▶ Other supplies: Materials and supplies associated with process monitoring are also necessary. These include one or more thermometers and possibly product testing equipment and supplies.

▪ **Cost: Labor and Equipment.** Labor and equipment costs are best considered together on an hourly basis, since composting operations generally require a combination of labor and equipment. The first factor to consider is the cost of labor. If hired labor will be conducting the actual composting, their hourly wage should be used. However, even if one is providing all the labor, a 'wage cost' of at least the current skilled labor wage rate should be charged to the composting operation, so that any net returns from composting can be considered profit, above and beyond any consideration of the cost of that time.

Next, the costs of all equipment such as tractors, front-end loaders, and manure spreaders must be considered. Equipment costs are often difficult to calculate. The first type of equipment cost to consider is the estimated cost to operate the equipment in the composting enterprise. This should include any fuel, oil, or other lubricant cost, as well as any expected repair or maintenance charges stemming from use of the equipment in composting. Typical operating costs of a \$24,000, 60-HP diesel tractor used 500 hours per year for 12 years are approximately \$4-\$5 per hour, while those of a \$41,000, 100-HP diesel tractor used at the same annual pace are approximately \$7-\$8 per hour (calculated from similar or identical equipment in Doane's *Agricultural Report Newsletter*, 1996).

The second type of equipment cost is the ownership cost — an estimate of the cost of owning the equipment, whether or not it is used. This

cost depends on the purchase price of the equipment, whether it was purchased outright or with a loan, the useful life of the equipment, the interest rate charged or opportunity cost of the money invested in the equipment, and the cost of insurance and housing. For the 60-HP tractor mentioned above, ownership costs might be approximately \$3,000 per year, or \$6 per hour if used 500 hours per year, while ownership costs of the 100-HP tractor might be \$5,200 per year, or \$9.50 per hour if used 500 hours per year (Doane, *ibid.*).

Don't forget to estimate costs for specialty equipment like tractor-mounted front-end loaders, manure spreaders, and compost turners. The combined annual ownership and operating costs for a typical 1-yard bucket used 200 hours per year would be \$3.50-\$4.50 per hour, and for a small manure spreader used 200 hours per year would be \$8.50-\$9.50 per hour (Doane, *ibid.*). If a compost turner is to be purchased, its cost should be a major focus of consideration. How large a composting operation will be needed to repay the investment of \$15,000 or more in a compost turner? For a \$15,000 tractor-pulled turner with a 12-year useful life, the annual ownership costs will be approximately \$2150 per year. Assuming that 50 yd<sup>3</sup> of finished compost can be produced per hour of turner time<sup>1</sup>, the hourly ownership and operating costs of the turner (without tractor or labor costs) when 7,500 yards of finished compost are produced will be approximately \$20 per hour (Doane, *ibid.*).

A few specific figures for system establishment and compost production have been reported. In active windrow composting, creating compost from yard trimmings and yard trimmings plus manures using standard farm equipment, and turning the material from one to a few times, has ranged from \$3 to \$7.50 per cubic yard of incoming material (Gresham, et al., 1990; Dreyfus, 1990; DeMuro, 1995). For aerated static pile composting, an investment of \$2,000 was required for the purchase and installation of a blower and piping at one central Virginia farm in 1996 in order to batch compost 80 tons of spent bedding from a cattle holding lot (T. Zentgraf, 1997). A 1992

---

<sup>1</sup> Based on a windrow of 1000 yd<sup>3</sup> of material being turned in 20-30 minutes, for a total of 25 times, and resulting in a material volume reduction of approximately 50% (from 1000 yd<sup>3</sup> to 500 yd<sup>3</sup>).

*operating* cost estimate for a static pile aeration system in the Northeast U.S. capable of handling approximately 200 tons of fish waste plus bulking agents was approximately \$2700/yr (NRAES, 1992).

▪ **Cost: Other Capital Costs.** Remember to put a value on the land which is used for the composting operation. At a minimum, figure the 'cost' of the land as the typical rental rate for similar land in the community.

Large capital investments of many thousand dollars may be necessary for site preparation and establishing all-weather road access to the composting site. These will vary greatly from site to site. In one case, the cost to grade a portion of fairly level pasture measuring 25 x 75 yards (0.38 acre) at a farm in northern Virginia and lay and compact a 5-6 inch base of roadbed-grade mixed stone and 2 inches of rock dust was approximately \$10,000 in 1994 (E. Polishuk, 1994). When calculating the annual cost of compost production, divide the site preparation and road access initial investments by the useful life of the principal equipment purchased (such as the compost turner). Add an additional annual fee for any interest charges and maintenance costs.

Included on the next page are two simple worksheets to help organize cost estimates: Worksheet 1 for recording labor and equipment use costs, and Worksheet 2 for computing the annual cost of compost production.

If some or all of the compost produced is to be sold, be conservative about both the sale prices that can be expected and the amount of compost that can be sold. It's better to be surprised that the operation did better than projected than it is to be dismayed about not fulfilling unrealistic expectations. If urban yard waste will be composted through a contract with a municipal authority, one's bargaining position depends on the existence of other farmer-bidders, the distance municipal trucks must travel to the farm, and the tipping fee for leaf waste disposal at local/regional landfills. If a contract is secured for urban yard waste, make sure that either debagging will be the responsibility of the municipal authority or that debagging costs are included in determining contract rate, along

with extraction of visible, non-compostable trash like toys, plastic bottles and rocks. Monitoring costs should be expected in order to make sure that incoming trucks and their loads are counted and to extract trash not found by urban crews. Worksheet 3 can be used to detail revenues.

## **J. INFORM AND EDUCATE NEIGHBORS**

It is extremely important to inform and educate neighbors about composting activities. Utilizing the support of Extension agents and state agency personnel can assist in easing concerns regarding traffic, noise, dust, odors, and environmental and health issues. Being prepared for discussions is very important in maintaining good relations. Accurately representing what changes will likely occur in farm activities and the steps being taken to minimize any potentially negative aspects of those changes will demonstrate consideration for and a desire to help ease neighbors' concerns.

<b>Worksheet 1: Labor and Equipment Tasks (simple windrow production system)</b>				
<i>Task</i>	<i>Labor Time</i>	<i>Labor Cost</i>	<i>Equip. Time</i>	<i>Equip. Cost</i>
Site Preparation				
Debagging or Trash Removal				
Windrow Formation				
Windrow Turning				
Windrow Wetting				
Windrow Monitoring				
Cleaning and/or Bagging				
Loading				
Delivery				

<b>Worksheet 2: Composting Enterprise Annual Costs of Producing _____ Units Compost</b>		
<i>Item</i>	<i>Quantity</i>	<i>Cost</i>
Cost: Materials and Supplies		
Nitrogen sources		
Carbon sources		
Other supplies		
Cost: Labor and Equipment		
Cost: Other Capital Costs		

<b>Worksheet 3: Composting Enterprise Annual Revenues</b>			
<i>Annual Revenue</i>	<i>Price</i>	<i>Quantity</i>	<i>Total</i>
Bulk Sales			
Pickup Sales			
Bag Sales			
Tipping Fees			

## VII. REGULATIONS: UNDERSTANDING AND COMPLIANCE

At the statewide level, composting activities in Virginia are regulated by the Department of Environmental Quality (DEQ). The Virginia Yard Waste Composting Facility Regulations (9 VAC 20-100-10 *et seq.*) and the accompanying statute establish the standards for siting, design, construction, operation, closure, and permitting of yard waste composting facilities. These allow all agricultural operations to compost farm manures and/or other agricultural wastes in combination with yard wastes. They also provide for some exemptions from operational and/or permitting requirements for various agricultural operations. (Note: In 1997 the yard waste composting regulations will be replaced by the Vegetative Waste Management and Yard Waste Composting Regulations (9 VAC 20-160-10 *et seq.*). However, these will contain essentially the same requirements for agricultural operations.

The Virginia Solid Waste Management Regulations establish the requirements for composting all materials other than yard and agricultural wastes. These are more stringent than those for yard waste composting and result in greater expense for permitting and compliance. Specifically, all composting sites must be hard-surfaced and provide for collection and treatment of runoff/leachate.

Following is a summary of some of the highlights of these regulations and the exemptions that govern agricultural operations<sup>2</sup>. Copies of all of these regulations are available from DEQ (See Appendix D).

## A. YARD WASTE COMPOSTING FACILITY REGULATIONS

▪ **Fully exempted facilities.** Agricultural operations conducting composting are exempt from ALL the regulations (i.e. siting, design, construction, operation, closure and permitting) under 2 scenarios:

1. When vegetative wastes and yard wastes generated on site are being composted with or without on- or off-site agricultural solid wastes<sup>3</sup>, *and*
  - a) all the compost is used at the operation,
  - b) all applicable local ordinances are observed, and
  - c) no nuisance or threat to human health or the environment results;

OR

2. When vegetative wastes and yard wastes which are received from off-site are being composted with or without on- or off-site agricultural solid wastes, *and*
  - a) all the material is composted and used within 18 months after it arrives,
  - b) no more than 6,000 cubic yards of vegetative and yard wastes are received each year,
  - c) the site has at least one acre available for receiving yard wastes for every 150 cubic yards of finished material generated during a year,
  - d) composting is not conducted in a flood plain or located within 300 feet of a property line or 1,000 feet of an occupied dwelling,
  - e) all applicable local ordinances are observed,
  - f) no nuisance or threat to human health or the environment results,
  - g) the owner submits a simple letter of certification (specified in the regulations) to the DEQ before receiving material for composting.

---

<sup>2</sup> An agricultural operation is any operation devoted to the bona fide production of crops, animals, or fowl, including but not limited to the production of fruits and vegetables of all kinds; meat, dairy and poultry products; nuts, tobacco, nursery and floral products; and the production and harvest of products from silviculture activities. (Code of VA, 9 VAC 20-10-10. *Definitions.*)

<sup>3</sup> Agricultural solid waste materials are defined as those normally returned to the soil, which are generated by the growing and harvesting of agricultural crops [spoiled hay, peanut hulls, corn stover] and the raising and husbanding of animals [e.g. animal manures, spent animal bedding] (Code of VA, 9 VAC 20-80-150.F).

▪ **Regulated facilities.** All agricultural operations conducting composting, but not meeting either of the 2 scenarios above must follow siting, design, construction, operation and closure requirements. Some of these operations may compost without a permit; others may not.

**Siting, Design, Construction, Operation, Closure:** Operations that compost greater than 6,000 cubic yards of yard waste per year and/or sell the finished compost must adhere to the following requirements:

- a) The site must not be within 200 feet of an occupied structure, in a flood plain or geologically unstable area, or closer than 50 feet to a regularly flowing stream.
- b) The site must have a buffer zone of no less than 100 ft between the process operations area and the boundary of the facility.
- c) The composting facility must be designed and operated such that non-vegetative wastes and other non-compostable materials are separated from those to be composted, and disposed of properly.
- d) No wastes other than vegetative and yard wastes and agricultural wastes may be composted.
- e) If the seasonal high water table is within 24 inches of the ground surface, the composting and handling areas must be hard-surfaced and bermed to manage runoff, runoff and leachate. No leachate or runoff must drain or discharge directly into surface waters.
- f) For other sites, the area need not be hard-surfaced, but must be graded to provide for the proper management of runoff, runoff and leachate.
- g) The roads serving the composting operation must be useable in all weather conditions.
- h) A manager / worker must be on duty during operation hours.
- i) A safety program, a fire prevention and suppression program, and controls for dust, odors and vectors must be in place.
- j) An approved closure plan that minimizes the need for future maintenance must exist. This closure plan needs to include the steps required for closing the operation at its peak, if that were to become necessary. It need not specify a closure date and can be amended as needed.

**Permitting- Exempted facilities:**

Agricultural operations that compost greater than 6,000 cubic yards of yard waste per year and/or sell the finished compost are not required to secure a permit if:

- a) Composting is not conducted in a flood plain, within 300 feet of a property boundary, or within 1,000 feet of an occupied dwelling;
- b) The site has at least one acre available for receiving yard wastes for every 150 cubic yards of finished material generated during a year;
- c) All the material is composted and used or sold within 18 months after it arrives;
- d) The owner or operator files an annual report when more than 6,000 cubic yards of yard waste is received from off-site during a year (report form provided by the DEQ);
- e) The owner or operator certifies that the facility complies with local ordinances; *and*
- f) The owner submits a letter (specified in the regulations) certifying that the operation is in compliance with these requirements, to the DEQ before receiving material for composting.

**Permitting- Non-exempted facilities:** Agricultural operations not meeting the above requirements must obtain a permit for operation. The operation will be issued a solid waste management facility permit (permit by rule), if the owner or operator provides:

- a) Documentation of legal control of the facility;
- b) Certification from the local government that the facility complies with all local ordinances;
- c) Certification by the owner that all the regulations are satisfied;
- d) Certification from a Virginia-licensed professional engineer that the facility complies with the design and construction requirements of the regulations (presented above);
- e) An operational plan and procedure for marketing or utilizing the finished product; *and*
- f) Proof of financial responsibility.

## **B. SOLID WASTE MANAGEMENT REGULATIONS**

For those Virginia farmers and other agricultural operation owners and managers who wish to compost additional materials such as food wastes, paper, biosolids or papermill sludge, the Solid Waste Regulations apply. These require, among other things, a paved surface for receiving, composting, and storing material; a leachate collection and treatment system; and the certification of a professional engineer. As of January 1997, the total permitting fee is \$9,700.



### APPENDIX A. COMPOSTING PROCESS RECORD TABLE

COMPOST PROCESSING RECORD												Windrow/Pile#	
date	time	rainfall/ weather	temperature		observations			activity*	equip.-code & time (hrs)	staff & time (hrs)			
			air	compost	moisture		odor						

\* activity examples: a) built 50' w' row = 6L:2.5CL (6 buckets leaves to 2.5 buckets chicken litter), added ~ 1000 gal. water; b) constructed pile on (date); c) turned w' row; added ~ 50 gal. water; d) added 'x' inches additional pile cover as biofilter

\*\* record several temperature readings (for windrows = approximately every 10-20 ft.; for piles = random all around)

## APPENDIX B. COMPOSTING TROUBLESHOOTING & MANAGEMENT GUIDE

(Reprinted with permission from *On-Farm Composting Handbook*, NRAES, 1992)

Condition	Possible source or reason	Other clues	Remedy
pile fails to heat	materials too dry	cannot squeeze water from material	add water or wet ingredients
	materials too wet	materials look or feel soggy; pile slumps; moisture content >60%	add dry amendments and remix
	not enough nitrogen, or slowly degrading or stable materials	C:N ratio > 50:1; large amount of woody materials	add high-nitrogen ingredients; change composting recipe
	poor structure	pile settles quickly; few large particles; not excessively wet	add bulking agent
	cold weather and small pile size	pile height < 3.5 ft.	enlarge or combine piles; add highly degradable ingredients
	pH excessively low	pH measures < 5.5; garbage-like odor	add lime or wood ash and remix
temperature falls consistently over several days	low oxygen; need for aeration	temperature declines gradually rather than sharply	turn or aerate pile
	low moisture	cannot squeeze water from material	add water
uneven temperatures or varying odors in pile	poorly mixed materials	visible differences in the pile moisture and materials	turn or remix pile
	uneven airflow or air short circuiting	visible differences in the pile moisture and materials	shorten aeration pipe; remix pile
	materials at different stages of maturity	temperature varies along the pile length	none required
gradually falling temperatures; pile does not reheat after turning or aeration	composting nearing completion	approaching expected composting time period; adequate moisture available; C:N ratio < 20:1	none required
	low moisture	cannot squeeze water from material	add water and remix
pile overheating (temperature >150°F)	insufficient aeration for heat removal	pile is moist	turn pile or increase the airflow rate
	moderate to low moisture; limited evaporative cooling	pile feels damp but not excessively wet	add water; continue turning & aeration to control temperature
	pile is too large	height > 8 ft.	decrease pile size

Condition	Possible source or reason	Other clues	Remedy
extremely high temperatures (>170°F) in pile: composting or curing/storage	pyrolysis or spontaneous combustion	low moisture content; pile interior looks or smells charred	decrease pile size; maintain proper moisture content; add water to charred or smoldering sections; break down pile, combine with other piles
high temperatures and/or odors in curing or storage pile	compost is not stable	short active composting period; temperature and odor change after mixing	manage pile for temperature and odor control, turn piles as necessary; limit pile size
	piles are too large	height > 8 ft.; width > 20 ft.	decrease pile size
ammonia odor coming from composting piles	high nitrogen level	C:N ratio < 20:1	add high-carbon amendments
	high pH	pH > 8.0	lower pH with acidic ingredients and/or avoid alkaline ingredients
	slowly available carbon source	large woody particles; C:N ratio < 30:1	use another carbon amendment or increase the carbon proportion
rotten egg or putrid odors coming from composting piles continually	<u>anaerobic conditions</u> materials too wet	low temperatures	add dry amendment
	poor structure		add bulking agent
	pile compacted		remix pile and add bulking agent if necessary
	insufficient aeration		turn pile or increase airflow
	aerobic conditions pile too large	high temperatures	decrease pile size
	airflow uneven or short-circuiting		remix pile; change recipe
odors generated only after turning	odorous raw materials	high temperatures	frequent turning; increase porosity; add odor-absorbing amendment
	insufficient aeration; anaerobic interior	falling temperatures	shorten time interval between turnings; increase porosity

Condition	Possible source or reason	Other clues	Remedy
site-related odors (piles not odorous)	raw materials	odor is characteristic of the raw material	handle raw materials promptly with minimal storage
	nutrient-rich puddles due to poor drainage	standing puddles of water; ruts in pad	divert runoff away; maintain pad surface
	holding pond or lagoon overloaded with nutrients or sediment	heavy algae and weed growth; gas bubbles on pond surface	install sediment trap; enlarge pond surface area; use runoff and pond water on cropland
fly or mosquito problems	flies breeding in compost piles	fresh manure or food material at pile surface; flies hover around piles	turn piles every 4 to 7 days; cover static piles with 6" layer of compost
	flies breeding in raw materials	wet raw materials stored on site more than 4 days	handle raw materials promptly
	mosquitos breeding in stagnant water	standing puddles of water; nutrient-rich pond or lagoon	grade site properly; maintain pad surface; maintain holding pond or lagoon in aerobic condition
compost contains clumps of materials and large particles; texture is not uniform	poor mixing of materials or insufficient turning	original raw materials discernible in compost	screen compost; improve initial mixing
	airflow uneven or short-circuiting	wet clumps of compost	screen or shred compost; improve air distribution
	raw materials contain large particles and non-degradable or slowly degradable materials	large, often woody particles in compost	screen compost; grind and/or sort raw materials
	active composting not complete	curing piles heat or develop odors	lengthen composting time or improve composting conditions

## APPENDIX C.

### CONTRACT ISSUES - COMPOST FEEDSTOCK DELIVERY/MANAGEMENT

Following are issues that should be considered in drafting a contract. This information is not intended to be utilized directly as a contract. It is for educational purposes only. It is highly recommended that a legal advisor be consulted for assistance and advice.

AT A MINIMUM, A CONTRACT SHOULD:

#### *Opening:*

- state who the parties are, e.g. farm owner/operator, yard waste collector/hauler, waste management agency.
- state that the parties agree to enter into a contract for yard waste delivery and composting.
- specify that the composting to be undertaken is considered a normal farming practice.
- state that each party shall carry appropriate liability coverage.

#### *Project and Operation Description:*

- assign responsibility to the Owner/Operator to:
  - provide a compatibly-zoned site for the composting facility,
  - provide all the necessary equipment and personnel for on-site composting,
  - perform site maintenance (as further specified in the contract) and perform all compost management operations,
  - comply with all applicable federal and state laws and regulations and local ordinances and statutes.
  - identify the location of the agricultural operation to be utilized for composting.

#### *Materials Characteristics:*

- specify type of materials that will be accepted, e.g.:
  - all municipal yard wastes consisting of grass clippings, leaves, brush, and tree pruning arising from general landscape maintenance;
  - only residential and commercial yard waste, and not yard wastes from industrial sites unless agreed upon by Owner/Operator;
  - leaves and grass only; no brush and tree trimmings or woodchips;
  - brush and tree trimmings not exceeding \_\_\_ inches in diameter;
  - woodchips from untreated wood products and not exceeding \_\_\_ inches in length and \_\_\_ inches in width.
- state who is to be responsible (Hauler/Waste Manager, Owner/Operator) for debagging and removing bags for disposal, if the material is delivered in non-biodegradable bags.
- state who is to be responsible for disposal of non-biodegradable bags.

#### *Materials Quantity:*

- specify the delivery manner and volume, e.g.:
  - loose (vacuum or transfer trucks): \_\_\_ volume/load; \_\_\_ # loads/week
  - bagged: \_\_\_ volume/load; \_\_\_ # loads/week
    - biodegradable bags
    - non-biodegradable bags

- specify an agreed upon delivered density of \_\_\_\_ lbs/cubic yard based on initial and regular assessment of the material (at periods of no less than \_\_\_\_ months), in order to allow the farm Owner/Operator to allocate sufficient but not unnecessary space and to plan composting activities (and, in the case of a tipping fee arrangement, insure proper compensation).
- specify that all loads are to be considered filled to capacity unless otherwise agreed after field testing.

In the Case of a Tipping Fee to Owner/Operator:

- specify how loads are to be counted (e.g. Owner/Operator shall be responsible for collecting delivery tickets indicating vehicle volume, when loads are delivered to the site, by means of a drop-box or other arrangement).
- state how and at what frequency (e.g. monthly, bi-weekly) the Owner/Operator shall submit a statement of delivered loads to the Hauler/Waste Manager, and how payment to the Owner/Operator for such deliveries is to be made (e.g. within 30 days).

***Materials Quality:***

- state that the Hauler/Waste Manager:
  - agrees to take reasonable precautions to ensure, to the greatest extent possible, that all loads delivered to the site under the contract are “uncontaminated,” (“contaminated” loads being those that are defined as containing quantities of non-organic waste materials estimated to be in excess of \_\_\_\_ percent by volume, of the total load delivered.)
  - shall indemnify (secure against hurt, loss, or damage) the Owner/Operator, those in her/his employ, and the farm property and natural resources for the delivery of and contamination from non-organic and/or hazardous materials contained in the delivered yard waste.
  - shall reimburse the Owner/Operator for any and all loss, damages, injuries (to person, property, or natural resources), cost, or expense arising in connection with the presence of non-organic and/or hazardous waste materials in the delivered yard waste.
- state that the Owner/Operator:
  - has the right to refuse any delivery because of “contamination.”
  - shall contact the Hauler/Waste Manager immediately, if any “contaminated” loads are brought to the site which require removal by the Hauler/Waste Manager or responsible parties.

***Additional Special Conditions or Specifications:***

- specify any that are applicable to the particular arrangement, site, or materials.

***Contract Terms:***

- specify that:
  - length of the contract shall be for \_\_\_\_ years, beginning \_\_\_\_\_ and ending \_\_\_\_\_;
  - delivery dates shall be from \_\_\_\_\_ through \_\_\_\_\_; and
  - delivery hours shall be from \_\_\_\_\_ to \_\_\_\_\_ .
 (Include that dates and operating days and times may be modified by mutual consent).
- provide for an optional contract renewal of \_\_\_\_ years, if desired, indicating that such renewal shall be made by mutual written consent on or before \_\_\_\_ days prior to the end of the contract, and shall be under the same terms and conditions.

**Costs:**

- assign responsibility for costs associated with:
  - all collection and delivery.
  - debugging and trash disposal (if applicable)
  - all material storage / handling, composting and end-use or sale costs following material delivery.
  - maintenance of entry / access roads and on-farm roads utilized for material delivery.

*(Costs may be assigned to one of the parties or shared by both).*

**In the case of a tipping fee to Owner/Operator:**

- specify that the Hauler/Waste Manager agrees to pay \$ \_\_\_\_ to the Owner/Operator for each:  
\_\_\_\_ yard; \_\_\_\_ ton of material delivered for the term of the Contract.

**Other:**

- close with signatures (written and printed) and date.
- 
-

## **APPENDIX D. COMPOSTING CONTACTS AND RESOURCES**

---

### **CONTACTS:**

Greg Evanylo, Assoc. Professor & Extension Specialist- Water Quality and Waste Management CSES Dept., 421 Smyth Hall, VA Tech, Blacksburg, VA 24061-0403; 540/231-9739; 231-3075 (fax); [gevanylo@vt.edu](mailto:gevanylo@vt.edu)

Archer H. Christian, Extension Research Associate- Composting/ Compost Utilization CSES Dept., 419 Smyth Hall, VA Tech, Blacksburg, VA 24061-0403; 540/231-9801; 231-3075 (fax); [archrist@vt.edu](mailto:archrist@vt.edu)

J. W. Pease, Assoc. Professor & Extension Specialist- Farm Management AAEC Dept., 312 Hutcheson Hall, VA Tech, Blacksburg, VA 24061-0401; 540/231-4178; 231-7417(fax); [peasej@vt.edu](mailto:peasej@vt.edu)

Eldridge Collins, Professor - Agricultural Waste Specialist BSE Dept., Seitz Hall, VA Tech, Blacksburg, VA 24061-0303; 540/231-7600; 231-3199(fax); [ecollins@vt.edu](mailto:ecollins@vt.edu)

Virginia Recycling Association- Organics Recycling and Composting Committee  
Bob Kerlinger, Chair, 20 Roberts Landing Dr., Poquoson, VA 23662; 804/868-3779; 868-3805 (fax)

Dr. Rosalie E. Green, Senior Recycling Specialist, USEPA  
109 Kent Dr., Manassas Park, VA 22111; 703/308-7268; 308-8686 (fax)

Mike Dieter, Environmental Engineer Senior Office of Permitting Management, Virginia Dept. of Environmental Quality  
POB 10009, Richmond, VA 23240-0009; 804/698-4146; 698-4383 (fax); [mjdieter@deq.state.va.us](mailto:mjdieter@deq.state.va.us)

The Composting Council, 114 South Pitt St., Alexandria, VA 22314  
703/739-2401; 739-2407 (fax); [comcouncil@aol.com](mailto:comcouncil@aol.com)

### **INTERNET RESOURCES:**

BioCycle Magazine - <http://grn.com:80/grn/news/home/biocyte/index.html>

Cornell Composting Website, Cornell Univ., New York - <http://www.cals.cornell.edu/dept/compost/>

Digital Learning Center for Microbial Ecology, Michigan State Univ. - <http://commtechlab.msu.edu/CTLprojects/dlc-me/zoo/zdcmain.html>

Environment Canada, Atlantic Region, Ottawa, Ontario - <http://www.ns.ec.gc.ca/atllhome.html>

Institute of Waste Management, Univ. of Essen, Germany - <http://www.waste.uni-essen.de/>

Recycling Council of Ontario (RCO) - <http://www.web.net/rco/> (Includes search engine to access more than 2,600 document abstracts)

Rot Web, Eric. S. Johnson, Boulder, CO - [http://net.indra.com/~topsoil/Compost\\_Menu.html](http://net.indra.com/~topsoil/Compost_Menu.html)

The Composting Council, Alexandria, VA - <http://www.adgrafix.com/boardz/composting.html>

The Composting Council of Canada, Ottawa, Ontario - <http://www.compost.org/english.html>

USDA Current Research Information System (CRIS) - <http://cristel.nal.usda.gov:8080> (Includes search engine to access 33,000 summaries of publicly supported agricultural, food and nutrition, and forestry research.)



**COMPOST QUALITY ANALYSIS and/or TESTING EQUIPMENT:**

A & L Eastern Agricultural Lab, 7621 White Pine Rd, Richmond, VA 23237; 804/743-9401

AAT Labs, Grand Rapids, MI; 616/241-6070

AgriEnergy Resources, Princeton, IL; 815/542-6424

Agricultural Consulting Lab, Rt. 1, Box 232, Mt. Crawford, VA 22841; 540/234-0059

Analytical and Biological Labs, Farmington Hills, MI; 313/477-6666

Autrusa Compost Consulting, POB 1133, Blue Bell, PA 19422; 610/825-2973; 825-3982 (fax);  
Autrusa@aol.com

Soil Control Lab, Watsonville, CA 95076; 408/724-5422; 724-3188 (fax)

Soil Logic, POB 21, Keswick, VA 22947; 804/295-7299 (representing Brookside Laboratories, Inc.)

Woods End Research Laboratory, Inc., Mt. Vernon, ME 04352; 207/293-2457; 293-2488 (fax)

---

**PUBLICATIONS:**

*BioCycle*, Journal of Composting & Recycling, *Composting methods and product use*. The JG Press, Inc., 419 State Ave., Emmaus, PA 18049; 610/967-4135. 1 yr (12 issues) = \$63

*On-Farm Leaf Mulching: An Option for Farmers and Municipalities*. 1996. A.H.Christian and G. Evanylo. Virginia Cooperative Extension Publication 418-017.

*On-Farm Composting Handbook*. 1992. Robert Rynk (ed.), Northeast Regional Agricultural Engineering Serv. 152 Riley-Robb Hall, Cooperative Extension, Ithaca, NY 14853-5701.

*The Rodale Book of Composting: Easy Methods for Every Gardener*. 1992. 278p. D. L. Martin & G. Gershuny, ed.s, Rodale Press, Inc., Book Reader Service, 33 East Minor St., Emmaus, PA 18098

*The Virginia Yard Waste Management Manual* (A hands-on guide for local gov't officials, Extension agents and private sector individuals). 1990. 139p. J.H. May & T.W. Simpson. Virginia Cooperative Extension Publication 452-055. (2nd edition in process)

*Virginia Organics Recycling and Composting Directory*. 1997. A.H.Christian and G.Evanylo (ed.s), Virginia Cooperative Extension Publication 452-230.

## REFERENCES

- Alexander, R.A. 1995. Standards and guidelines for compost use. p.68-70. *In: Farm Scale Composting*, JG Press, Inc., Emmaus, PA.
- Composting Council. 1994. *Compost Use Guidelines*. Composting Council, Alexandria, VA.
- Composting Council. 1996. *Field Guide to Compost Use*. Composting Council, Alexandria, VA.
- DeMuro, P. 1995. Composting economics for landscapers. *BioCycle*, 36(6):33-34.
- Doane Western, Inc. *Doane's Agricultural Report Newsletter*, May 31,1996. , St. Louis, MO.
- Dreyfus, D. 1990. *Feasibility of On-Farm Composting*. Rodale Institute Research Center, Kutztown, PA.
- E&A Environmental Consultants, Inc. 1995 *Laboratory Manual*. E&A, Inc., Cary, N.C.
- German, Carl, U. Toensmeyer, J. Cain, and R. Rouse. 1994. *Guide to Planning the Farm Retail Market*. Univer. of Delaware Cooperative Extension Bulletin #52.
- Grebus, M.E., M.E.Watson and H.A.J.Hoitink. 1994. Biological, chemical and physical properties of composted yard trimmings as indicators of maturity and plant disease suppression. *Compost Sci.&Util.*, 2(1):57-71.
- Gresham, C.W., R.R.Janke, and J. Moyer. 1990. *Composting of Poultry Litter, Leaves, and Newspapers*. Rodale Institute Research Center, Kutztown, PA.
- Hoitink, H.A.J., M.J.Boehm, and Y.Hadar. 1993. Mechanisms of suppression of soilborne plant pathogens in compost-amended substrates. p.601-621. *In* H.A.J.Hoitink and H.M.Keener (eds.) *Science and Engineering of Composting: Design, Environmental, Microbiological and Utilization Aspects*. Renaissance Pubs, Worthington, OH.
- Logsdon, G. 1995. Using compost for plant disease control. p58-60. *In* J. Goldstein (ed.) *Farm Scale Composting*, JG Press, Inc., Emmaus, PA.
- McNelly, J. 1989. *Yard Waste Composting Guidebook for Michigan Communities*. Michigan Department of Natural Resources, Lansing, MI.
- NRAES. 1992. *On-Farm Composting Handbook*. Robert Rynk (ed.), Northeast Regional Agricultural Engineering Service, 152 Riley-Robb Hall, Cooperative Extension, Ithaca, NY 14853-5701.
- Polishuck, E. 1994. Farm Manager, Potomac Vegetable Farm, Purcellville, VA, Personal communication.
- Stofella, P.J., Y Li, D.V. Calvert, and D.A.Graetz. 1996. Soilless growing media amended with sugarcane filtercake compost for citrus rootstock production. *Compost Sci.&Util.* 4(2):21-25.
- Tripepi, R.R., X. Zhang, and A.G.Campbell. 1996. Use of raw and composted paper sludge as a soil additive or mulch for cottonwood plants. *Compost Sci.&Util.* 4(2):26-36.
- Zentgraf, T. 1997. Consultant, Soil Logic, Keswick, VA, Personal communication.



[www.ext.vt.edu](http://www.ext.vt.edu)

Produced by Communications and Marketing, College of Agriculture and Life Sciences,  
Virginia Polytechnic Institute and State University, 2009

Virginia Cooperative Extension programs and employment are open to all, regardless of race, color, national origin, sex, religion, age, disability, political beliefs, sexual orientation, or marital or family status. An equal opportunity/affirmative action employer. Issued in furtherance of Cooperative Extension work, Virginia Polytechnic Institute and State University, Virginia State University, and the U.S. Department of Agriculture cooperating. Mark A. McCann, Director, Virginia Cooperative Extension, Virginia Tech, Blacksburg; Alma C. Hobbs, Administrator, 1890 Extension Program, Virginia State, Petersburg.