

**LEARNING TO JUMP: A LESSON MANUAL  
FOR THE NOVICE RIDER**

by

**Daniela Simone Meyer**

**Major Paper submitted to the Faculty of the  
Virginia Polytechnic Institute and State University  
in partial fulfillment of the requirements for the degree of**

**MASTER OF SCIENCE  
IN  
ANIMAL AND POULTRY SCIENCES**

**APPROVED:**

---

**Larry A. Lawrence, Chair**

**December 10, 1996  
Blacksburg, Virginia**

**Key Words: Equitation, Jumping, Manual, Horse**

C.2

LD  
5655  
V851  
1976  
M494  
C.2

# EQUITATION OVER FENCES: A LESSON MANUAL FOR THE NOVICE RIDER

by

Daniela Simone Meyer

Dr. Larry Lawrence, Chairman

Department of Animal and Poultry Sciences

(ABSTRACT)

The objectives of the manual are to introduce jumping to the novice rider, and serve as a guide for the initial steps of jumping. The manual covers the two-point position, the key component of learning to jump.

The jumping procedure is divided into four sections including: trotting poles, riding cross rails, verticals, and oxers. Trotting over poles gives the rider a feel for steering and movement of the horse.

A cross rail may be added to the end of the combination of trotting poles. A cross rail assists the rider in steering to the center. Once the rider is confident with the cross rail, the rider may proceed to a vertical. The next step may be removal of the trotting poles and continuing with the exercise at the canter.

Progress from the two-point position requires the rider to know how to perform the crest release. The crest release is demonstrated in the manual. This release allows the horse to use its neck over the jump. The rider must now be able to balance their position and weight with their leg.

- The two different types of lines, straight and bending, are explained and illustrated in the manual. Stride measurements are indicated for the rider to set up correct distances between two jumps. A one strided line referred to as an in-and-out is described in the manual.

Finally, three different types of oxers are illustrated. Technique and structure of the oxers are explained to the rider.

**Key Words:** Equitation, Jumping, Manual, Horse

## **Dedication**

I dedicate this manual to Twidd, Nightcap, Princess, Opus, Tassy, Cinderella, and Cappy for their knowledge and teaching ability. I would not be where I am today if it had not been for these horses.

## **Acknowledgements**

I would like to thank my parents for their endless support. I owe you more than I could ever return. Thank you for convincing me to go on with my studies and being there for me every step of the way. I hope I have made you proud. I would like to thank Dr. Larry Lawrence, my major professor, without whom I would not have graduated with my Master's degree. Thank you for taking me under your wing and giving me the chance to continue on with my education. You steered me in the right direction and I greatly appreciate it. I would also like to thank Pablo Schurig for the illustrations in this manual. Finally, I would like to thank Thomas for his love and moral support. I could not have done it without you.

## Table of Contents

I. Introduction-----	1
II. Background-----	2
III. Jumping Procedure-----	3
a) Trotting a pole-----	3
b) Trotting two poles-----	3
c) Trotting a cross rail-----	4
d) Trotting a vertical-----	5
e) Canterng the vertical-----	5
f) Releasing the mane-----	6
g) Jumping a line-----	6
h) Riding the in-and-out-----	7
i) Jumping an oxer-----	7
IV. Conclusion-----	9
V. Suggestive Reading-----	10
VI. Figures	
Figure 1-----	11
Figure 2-----	12
Figure 3-----	13
Figure 4-----	14
Figure 5-----	15
Figure 6-----	16
Figure 7-----	17
Figure 8-----	18
Figure 9-----	19
Figure 10-----	20
Figure 11-----	21

# Introduction

## ***Things To Know***

- Flat-work (under saddle): Exercises that do not involve jumping. Control of the horse at all gaits is considered flat work.
- Getting sour: The horse has been jumped too much and begins to resent or avoid the rider. The horse will resist the rider's aids.

Every day thousands of riders begin the adventure of learning how to jump. Before learning to jump the rider should have successfully completed most of the flat-work exercises. Flat-work is the prerequisite for jumping. The manner in which the horse jumps depends on its knowledge and competency working under saddle. All jumps described in this manual are basic structures. The objective of this manual is to introduce jumping to the novice rider and guide him/her through the initial steps of jumping. This manual will not cover riding courses or course designing.

## ***Equipment.***

The rider should possess a riding helmet with proper harness. Boots with one inch heels are recommended. Riding breeches or chaps are acceptable. The rider should use caution when riding in jeans. The material promotes painful skin abrasions.

## ***The rider.***

As in any sport, practice makes perfect. Both the horse and the rider need to understand the concepts of the exercises. The exercises in this manual take time and work. The more effort put forth, the more success and satisfaction the rider will receive in return. Although this manual is a guideline for learning how to jump, professional assistance and/or instruction is strongly recommended. Professional instruction is essential if the rider or horse is having difficulty completing a step. One step builds on the next. Each exercise should be completed in order. If progress seems slow, assistance may be the solution.

## ***The horse.***

This manual should not be completed in one or two days. Rider enthusiasm is commendable, but the horse should not be overworked. The rider must moderate the horse's activity. If the manual states to perform an exercise several times, it may be ridden five or six times and no more. Overworking the horse in jumping can cause the horse to become lame or get sour. Giving the horse a week or two of vacation may help remedy the situation.

## ***Matching horse and rider.***

At this stage in training, it is important for the rider to be familiar with the horse's attitude and training level. Young or green horses and novice riders are an unsafe combination. Only the rider, or the horse, can be taught to jump at one time.

All riders benefit from getting the opinions of a variety of trainers. The advice that works best will create a more secure and effective rider. The rider should begin each riding session with a few minutes of review. After the review the rider may continue to the next step.

## Background

To begin jumping, the rider should be familiar with certain basic exercises. The rider should be able to control the horse at all three gaits (walk, trot, canter), as well as be able to perform a sitting trot and halt. Control of the horse is critical in jumping. The horse must be under control before and after the fence.

### *The two-point position.*

A two-point or jumping-position trot is important (Fig. 1) as it is essential for jumping. The rider should master this position. Review the following steps for establishing the two-point position. Mount the horse and keep the animal at a halt. After mounting, grab a handful of mane half-way up the crest. The elbows are bent and the arms are partially extended (Fig. 1). The rider should push down into the heels. The leg should remain on the horse's side without swinging back. It will become easier for the rider to prevent the leg from moving once the position becomes more secure. The upper body should bend forward about 30 degrees from the vertical. To avoid getting ahead of the horse's forward motion, maintain a seat barely touching the saddle. The rider's back should remain straight at all times.

### **Building a rider's equitation without stirrups**

Learning to ride without stirrups is a classical equitation training exercise. This exercise should be started under guidance of an instructor. To enhance correct use of aids and equitation, all gaits should be performed without stirrups. This technique allows the leg to relax and extend down. Elongating the leg positions the calf on the horse's side. The elements of an elongated leg, correct calf position, and weight in the heels, prevent gripping and pinching with the knee. Proper equitation will enhance effective jumping.

# Jumping Procedure

## *Trotting a pole.*

### **Things To Know**

- Standard/wing: A structure that is placed on either side of a pole/jump to prevent the horse from running out on the side of the jump.
- Running out: The horse avoids jumping by drifting to one side of the jump and running past it.
- Rhythm (pace): The continuity with which the horse moves forward. Stride length and speed should be the same for each stride.
- Falling behind: When the rider loses the proper position and falls back into the saddle. This could be caused by the horse taking a long distance (see cantering a vertical).

The first exercise consists of trotting over a single pole on the ground. The pole should be clear of any obstacles. A colored pole will be easier for the horse to differentiate from the ground. Place the pole with one end against the fence/railing of the ring and place a standard on the inside end. This decreases the opportunity for the horse to run out.

The two-point position will be used to trot over the pole. Figure 2 shows how to set up two poles, but at this time use one pole. While trotting the pole, a bounce in the heel should be the rider's only movement. The upper body should remain quiet. In order to counteract the trot-bounce, the calf should be held tightly on the horse's side and the ankle should act as a shock absorber. Allow for adequate space on each side of the pole to approach and ride away in a straight line. This allows the horse to look at the jump/pole. The rider should never look down. Focus the eyes up on something in the distance. Looking in the direction of travel serves as an aid to the horse. Continue trotting a straight line after the pole and halt a few strides later. This step should be repeated until it feels comfortable.

Rhythm is the key to success. The rider should maintain the same speed and stride length throughout the exercise.

Maintaining proper leg contact will prevent the rider from falling behind the motion of the horse. Due to the sensitivity of the horse's back, all caution should be used to avoid this. The two-point position allows the rider to follow the motion of the horse.

## *Trotting two poles.*

### **Things To Know**

- Dropping/stretching weight into the heels: The rider should push down in the heels and lift their toes up.

The next stage consists of trotting over two poles. Place another pole 4 feet behind the first one, as depicted in Fig. 2. Four feet is the average trotting pole distance. However, the distance between the poles may be increased or decreased according to the

horse's stride length. The horse's feet should land half-way between the two poles. It would be helpful for an assistant to watch the rider complete the exercise and move the poles accordingly.

Maintain proper form over both poles. Dropping weight into the heels, focusing up, and holding the upper body at the 30 degree angle exemplifies proper execution.

Increasing the number of poles is a good exercise. Up to four poles can be set up. This exercise is always a good review and warm-up. The effectiveness of this exercise is dependent upon lower leg contact and focusing the eyes up.

Removal of the standards/wings will test the rider's accuracy of riding to the center of the poles. The rider should prevent drifting off of the center line by utilizing strong leg aids. Figure 3 shows an example of where the horse is drifting right and the rider is applying the right leg to straighten the horse. In a competent rider, leg aids are the fundamental tool for successful riding.

### ***Trotting a cross rail.***

#### ***Things To Know***

- Cross rail: A jump that consists of two poles crossed at the center. One end of the first pole is raised on the standard and the opposite end of the second pole is raised to the same height on the other standard.
- Ground lines: These poles are placed immediately in front of the jump. They assist horses in judging the distance. The ground lines should be placed on the side of the jump from which the horse and rider approach. Placing ground lines on both sides allows the rider to jump from either direction.
- Hitting the horse in the mouth: This occurs when the rider gets left behind the motion of the horse and aggressively pulls back on the horse's mouth. This is very uncomfortable for the horse.
- Longeing: The rider handles the horse on a very long lead rope (longe line). The horse moves in a circle around the rider performing different gaits.

Figure 4 illustrates the set up of a cross rail. A good rule of thumb is to place the cross rail double the trot distance from the last trotting pole. For example, if the trotting poles are 4 ft apart, then the distance between the last trotting pole and the cross rail is 8 ft (Fig. 4). The maximum height of the center of the cross rail should not exceed 18 inches. To help horses judge distances for take-offs, a ground line must be placed at every jump. A ground line consists of one pole placed immediately in front of the jump as illustrated in all jumping diagrams.

The rider should trot through the poles in two-point and continue on to the cross rail. To avoid being thrown out of position, grabbing the mane in two-point will help maintain balance of the rider (Fig. 5). Being thrown out of position results in the rider landing hard on the horse's back and hitting it in the mouth. These are two major faults that may lead to refusals.

This exercise should be performed regularly. The rider's elbows should be bent when going over the fence and straightened on the landing. Staying in two-point allows

the horse to jump up and meet the rider's body. Mistakes magnify as fence heights increase. Errors in form, position, and approach must be eliminated before attempting higher fences. Jump height should be adjusted carefully a few inches at a time.

Another cross rail exercise can be performed on the longe line (Fig. 6). A cross rail should be set up on the circle where the horse and rider will be longed. An experienced horse person should longe the rider. This exercise allows the rider to concentrate on equitation. Following the movement of the horse and not anticipating the jump improves the rider's balance. When comfortable with trotting the cross rail on the longe line, the rider can proceed independently.

### ***Trotting a vertical.***

#### ***Things To Know***

- Vertical: A jump that has one pole raised up on the standards, but remains parallel to the ground. Most jumps in the show ring or cross country courses are modifications of verticals or oxers.
- Cavaletti: A small version of a vertical. Usually the standards consist of crosses and the pole is elevated by placing the ends of the pole into the crevices of the crosses.

Trotting a vertical is the next step in progression for the rider. Figure 7 illustrates the structure of a vertical. Riding to the center of the fence is critical. A cavaletti can be used in place of a vertical jump. Begin all new exercises at low heights. Initial trotting height should be one foot.

The horse should be kept at a trot up to two feet in jumping height. If the jump exceeds two feet in height, the horse may need to canter to gain adequate momentum to clear the fence. This exercise should be ridden multiple times.

### ***Cantering the vertical.***

#### ***Things To Know***

- Take-off (distance): The place where the horse's front feet land before it jumps into the air over a fence.

To prepare for a vertical, canter a lowered cross rail. Grabbing the mane over the fence may help build confidence. At the faster gait, the rider must keep the horse straight. This reduces the chance of running out. This exercise should be repeated several times.

The rider may experience a variety of take-offs (Fig. 8a,b,c). The first distance shown in Figure 8a is referred to as a "long" distance. The long distance take-off may result in the rider getting left behind. Ideally, the take-off and landing are the same distance from the fence (Fig 8b). This results in a desirable jump. If the horse takes an extra stride before the fence, it is known as a "chip". The short take-off is depicted in Figure 8c.

One of the most common mistakes made by novice riders is getting ahead of the horse's motion. Rhythm is the key to success. If the rider can maintain the horse at the

same pace, the chance of finding a comfortable distance is greater. The rider should avoid changes in pace, i. e. speeding up or slowing down. Rhythm makes the overall picture of the jump more attractive. The goal is to control the horse in a subtle and calm manner.

### ***Releasing the mane.***

#### ***Things To Know***

- Crest release: The rider's hands move half way up the horse's neck. The rider's upper body leans forward to meet the horse over top of the jump.

Learning to release the mane requires the rider to be in the vertical position (Figure 9, dotted outline). The upper body should not slouch. Constant contact with the horse's mouth should be maintained. There should be a straight line from the rider's forearm to the reins leading to the horse's mouth. The reins should not be too long or too short. If they are too long, the rider will have no control over the horse. If they are too short, the rider will be pulling on the horse's mouth continuously. Hold this position when approaching the fence. Concentrate on keeping the eyes focused up. Looking down at the jump will cause the upper body to lean forward and shift the weight of the rider.

While at a halt, the rider should mentally picture the position and crest release over top of the fence. Practice this at the halt as shown in Figure 9.

The hands should remain close together on the release. Over top of the jump, the hip angle should close about 30 degrees. A strong leg is needed to keep the rider's balance.

### ***Jumping a line.***

- Straight line: Two jumps set up on the same path of travel, separated by indicated footage. The first jump cannot be an oxer (see jumping an oxer).
- Bending (broken) line: Two jumps not set up on the same path of travel. The rider is required to approach, jump, and land straight from the first fence and then turn the horse about 90 degrees to the second jump.

The rider should set up a second vertical on the same line as the first. Figure 10 illustrates the line. Route "a" is termed a "straight line". The standard footage for 1, 2, 3, 4, 5, 6, 7, and 8 strides are 24, 36, 48, 60, 72, 84, 96, and 108 ft., respectively.

Depending on the horse's stride length the line may need to be lengthened or shortened. When the rider trots in to the first fence, one stride needs to be added between the two jumps. Focus on rhythm and pace. Learn to count the numbers of strides between the fences.

Learning the length of the horse's stride is very important. Another exercise to assist in this learning process can be performed by placing a single pole on the ground and cantering over it. The rider should count down the strides (Stride 8, 7, 6, 5, etc.) to the pole. Counting down the strides helps the rider develop a sense of location in the line. This exercise is less strenuous on the horse than jumping a fence and can therefore be repeated multiple times. Experience with this exercise allows the rider to realize if the

horse's pace needs to be adjusted.

The second type of line is called a "broken- or "bending line" (Figure 10, route b). Stride numbers will vary in this situation. The greater the bend between the two jumps, the more strides that need to be added. A common problem with bending lines are the run-outs at the second fence. Riders that allow their horses to drift through the turn, usually cannot bring the horse back in line to jump the second fence. The rider needs to support the horse's bend with the outside leg. For example, if the horse is bending right, but drifting left (the horse's head is turned right), the rider's left leg needs to assist. Usually, a shorter rein is required for more control. The rider should use the legs as the major steering device and only assist with the hands. Start this exercise at a lower height and move the height up as confidence builds.

### ***Riding the in-and-out.***

- |   |
|---|
| <ul style="list-style-type: none"><li>- In-and-out: Two jumps set up as a line with one stride (24 ft) between them. The first fence cannot be an oxer.</li></ul> |
|---|

The most important aspect of riding through an in-and-out is holding the shoulders back, carrying the weight in the heels, and riding in a balanced seat. The one stride in-and-out leaves little margin for correction of an error.

A shift of weight (leaning forward) can throw the horse off balance, resulting in chipping the first fence and refusing the second. Often the in-and-out is used to correct jumping errors made by both the horse and rider. The one stride allows the rider to focus on equitation and form rather than distances.

### ***Jumping an oxer.***

- |   |
|---|
| <ul style="list-style-type: none"><li>- Oxer: A jump that is made up of two verticals. The verticals are set up about 1 ft apart. The jump resembles a box.</li></ul> |
|---|

There are three types of oxers: the ascending oxer, the parallel oxer, and the Swedish oxer. To build the ascending oxer (Fig. 11a), set up two verticals with approximately one foot between them. In the ascending oxer, the second vertical is higher than the first. Place the ascending oxer as the second element of the in-and-out. The first oxer ridden should be about two feet in height. The second pole should reach two feet and the first about one and a half feet. It is suggested to ride this a few times to get comfortable with the jump. The horse will remain in the air longer and tuck its knees up higher to clear the fence.

The parallel oxer consists of two verticals set up at the same height (Fig. 11b). Begin the exercise at a 2 foot height. This oxer is more difficult. The horse needs to tuck up sooner with its front end due to the higher front pole. Since both poles are the same height, the horse may not see the second pole until approaching take-off.

Finally, there is the Swedish oxer (Fig. 11c). This jump is primarily used in jumper courses. It is rarely seen in hunter classes. This oxer resembles a cross rail, only higher and with an increased spread. To build the Swedish oxer, the first vertical needs to

be set up so that one end of the jump is at one foot and the other at two feet. The second vertical behind it should have the opposite settings.

The horse should not be over-jumped. Increasing the height or spread of the fences is demanding on the horse. Avoid over-working the horse with these difficult exercises. Oxers and in-and-outs should not exceed 2 feet and 6 inches in height at this stage of riding.

## **Conclusion**

Completion of this manual provides a basis for jumping cross rails, verticals, lines, and oxers. This text is designed to supplement additional reading and professional instruction. The elements described in this manual are all necessary for riding courses. Before attempting to ride courses, the rider should master each of the various elements. Good luck and successful jumping as you continue your riding career.

## Suggestive Reading

- Crumb, M. and C. M. Thomas. Manual for Learning to Jump Step by Step. University of Idaho, Cooperative Extension Service. H - 30.
- Gordon-Watson, M. and W. Steinkraus. 1982. The Handbook of Riding. Alfred A. Knopf, Inc., New York.
- Harris, S. E. 1994. The United States Pony Club Manual of Horsemanship: Basics for Beginners. Howell Book House, New York.
- Harris, S. E. 1995. The United States Pony Club Manual of Horsemanship: Intermediate Horsemanship. Howell Book House, New York.
- Morris, G. H. and C. Homfeld. 1990. 3rd ed. Hunter Seat Equitation. Doubleday & Co, Inc, New York.
- Morris, G. H. and G. Wright. 1981. George H. Morris Teaches Beginners to Ride. Doubleday & Co, Inc., New York.
- White-Mullin, A. J. and G. H. Morris. 1993. Judging Hunters and Hunter Seat Equitation. Trafalgar Square Publishing, Vermont.

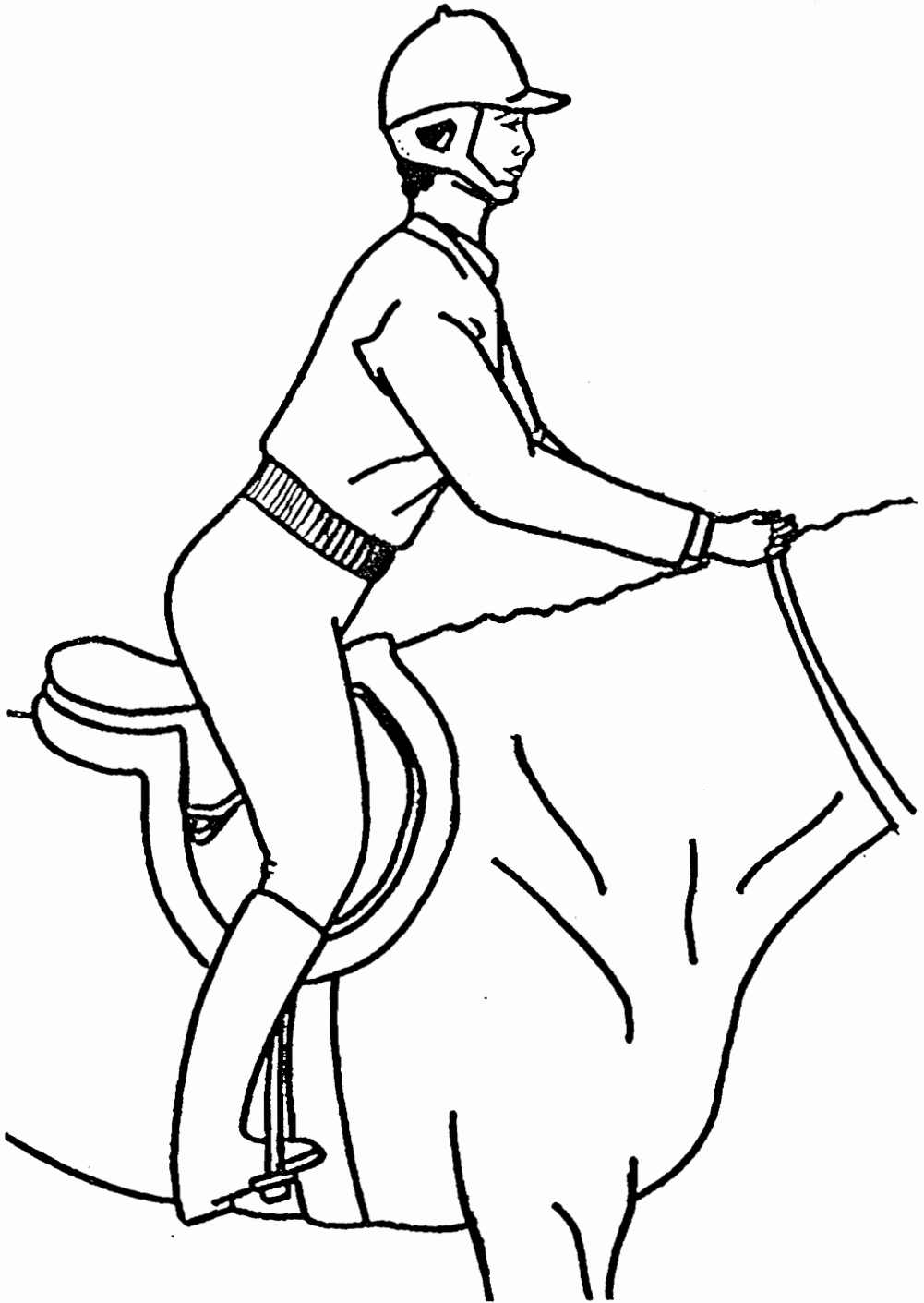

Figure 1. The two-point position.

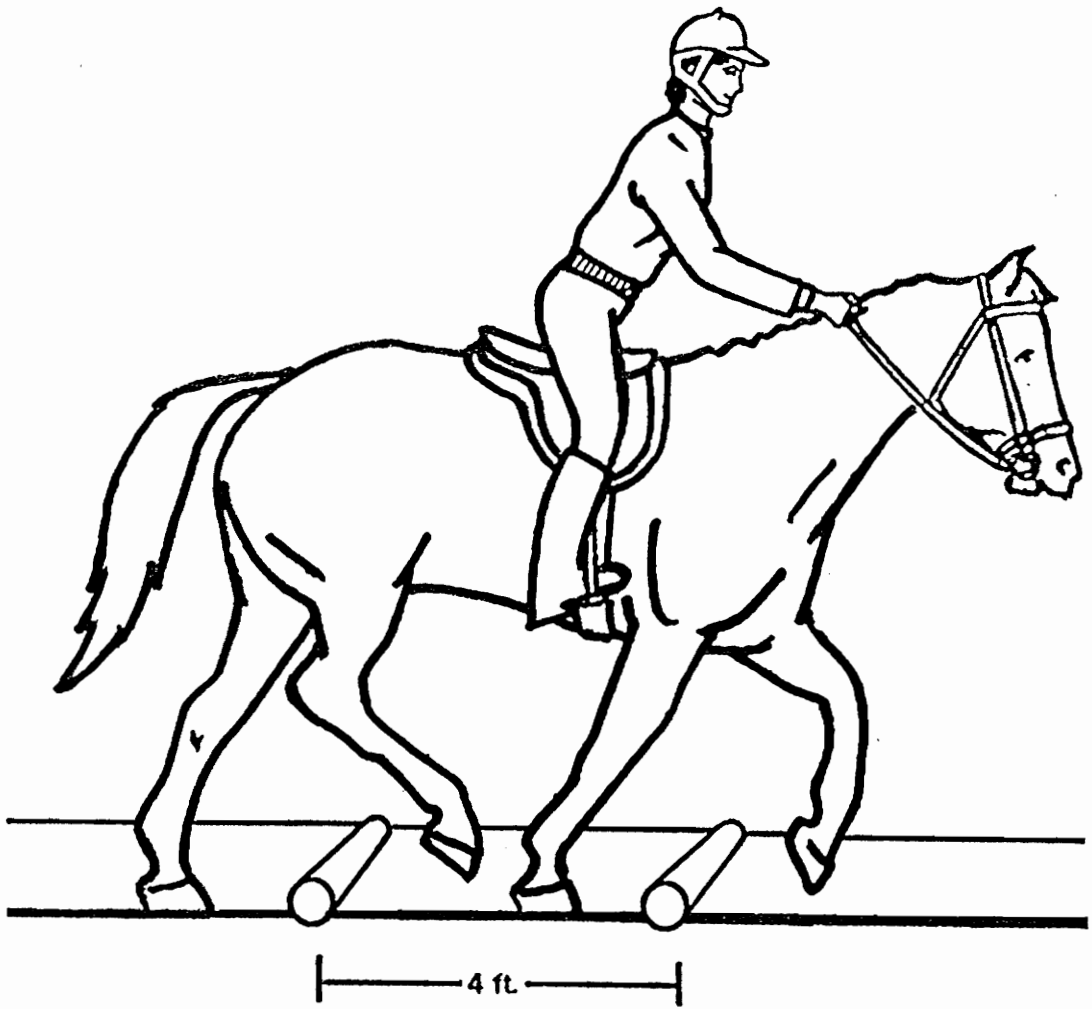

Figure 2. Horse and rider trotting over poles on the ground.

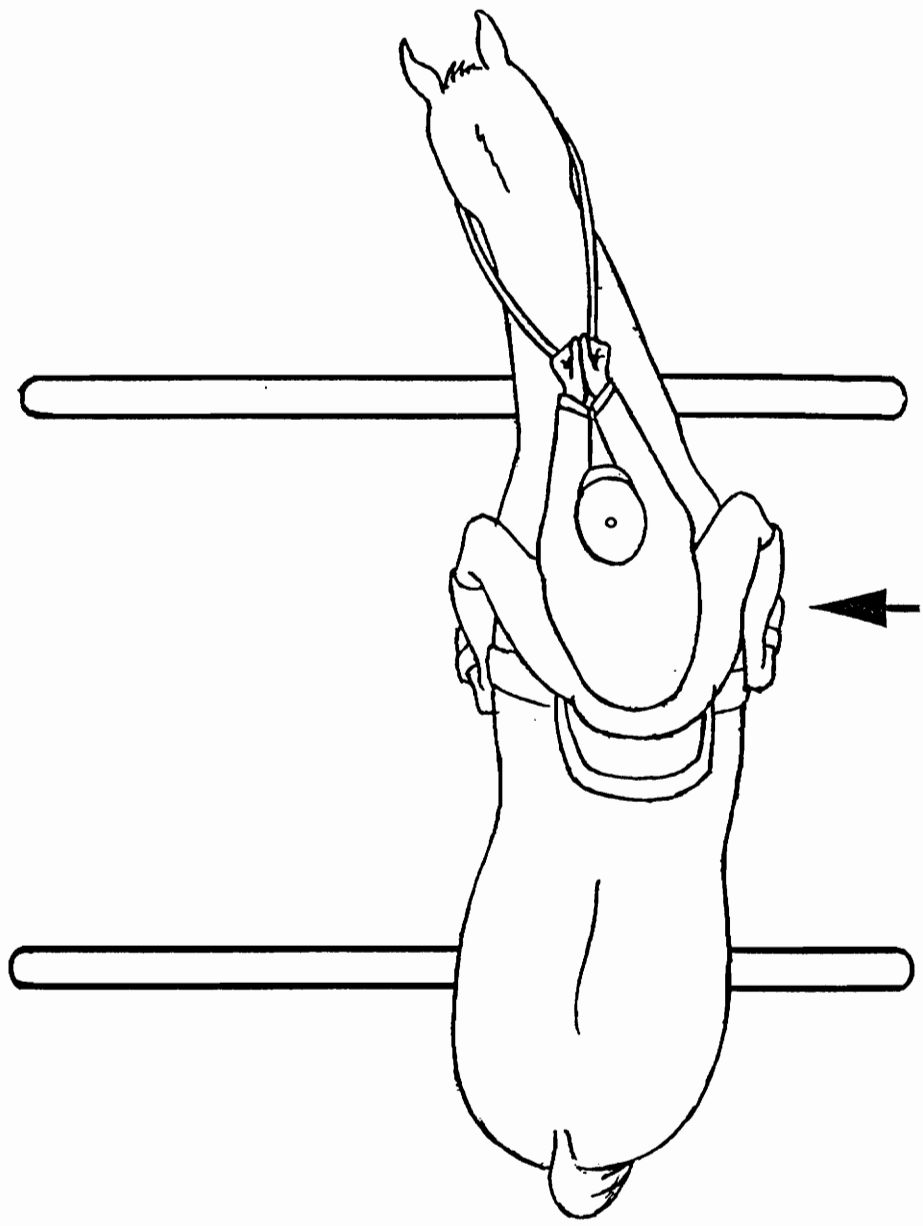

Figure 3. The rider is counteracting the drifting of the horse by squeezing with the right leg (arrow).

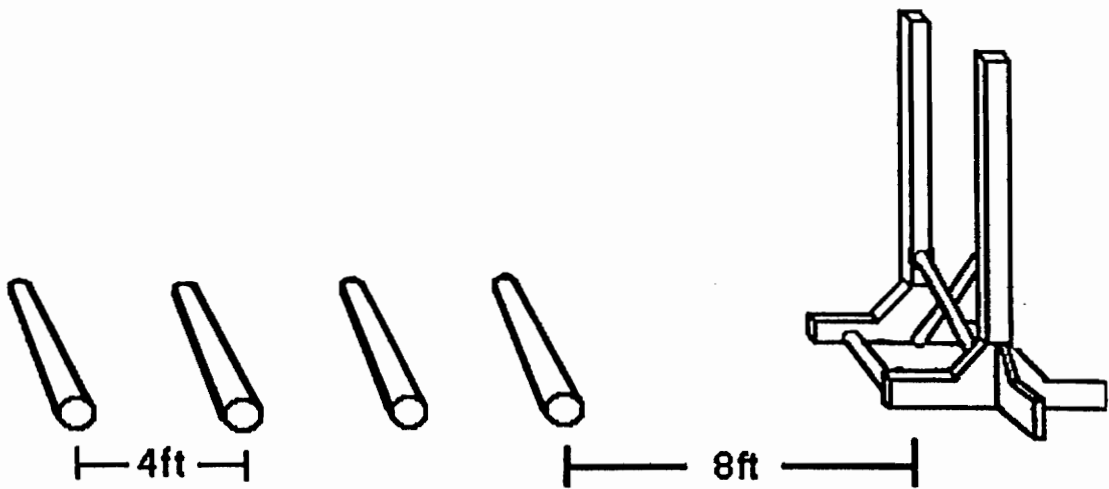

Figure 4. Trotting poles leading to a cross rail set-up. The general distance between trotting poles is 4 ft and between the last trotting pole and cross rail is 8 ft.

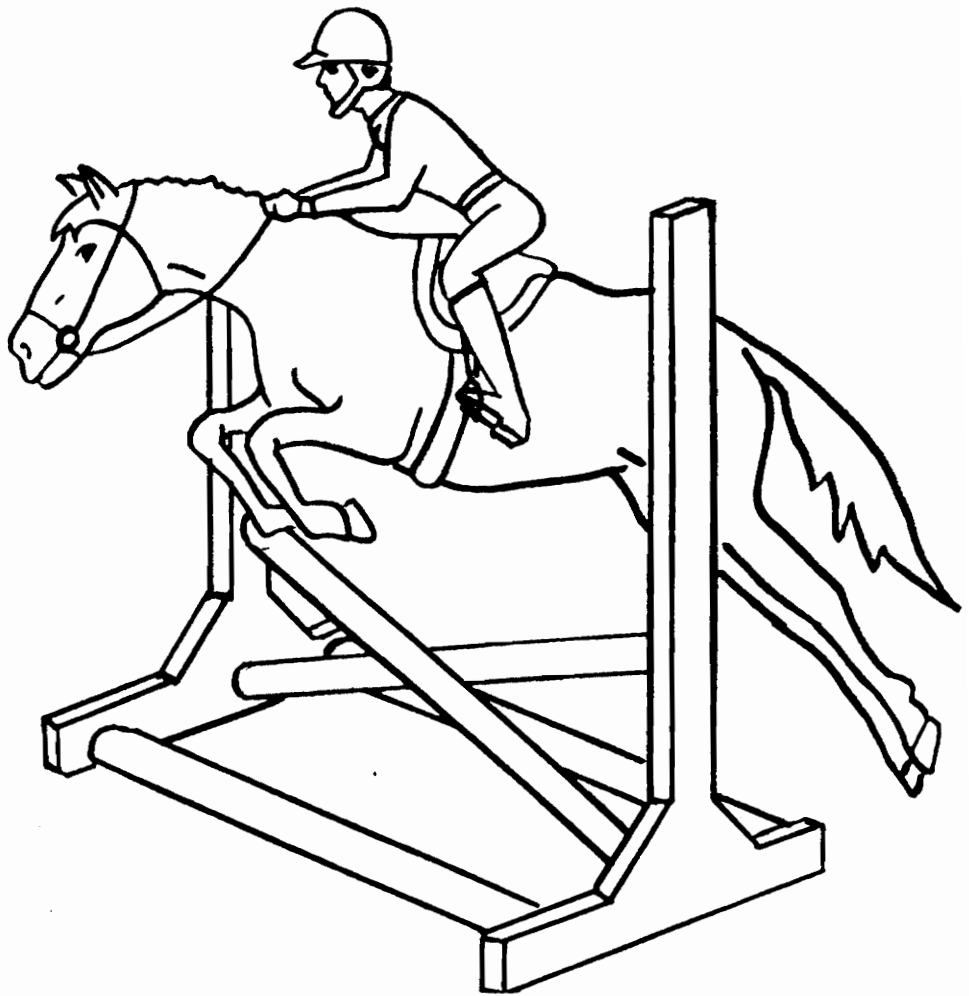

Figure 5. Proper equitation of the rider over the cross rail.

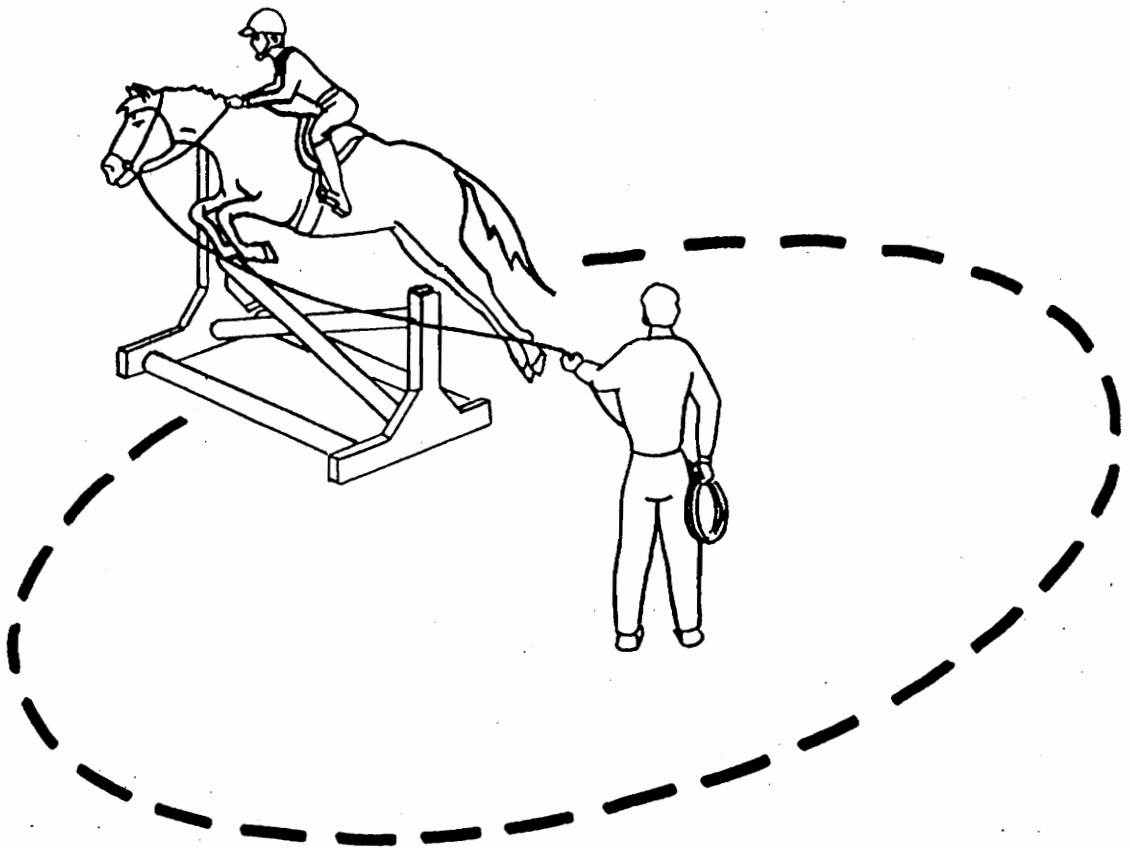

Figure 6. The rider is being longed over the cross rail by an experienced horse trainer. Dotted line depicts path of horse.

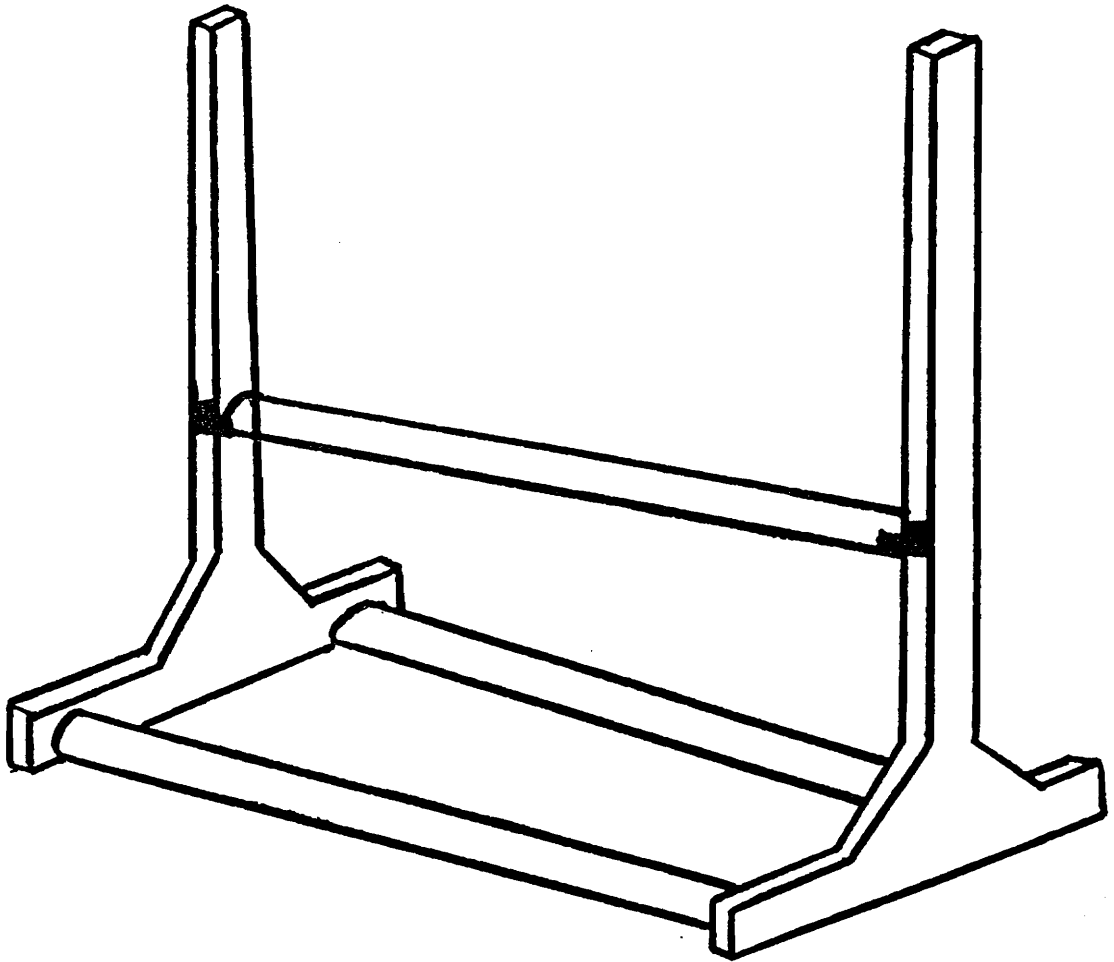

Figure 7. The vertical.

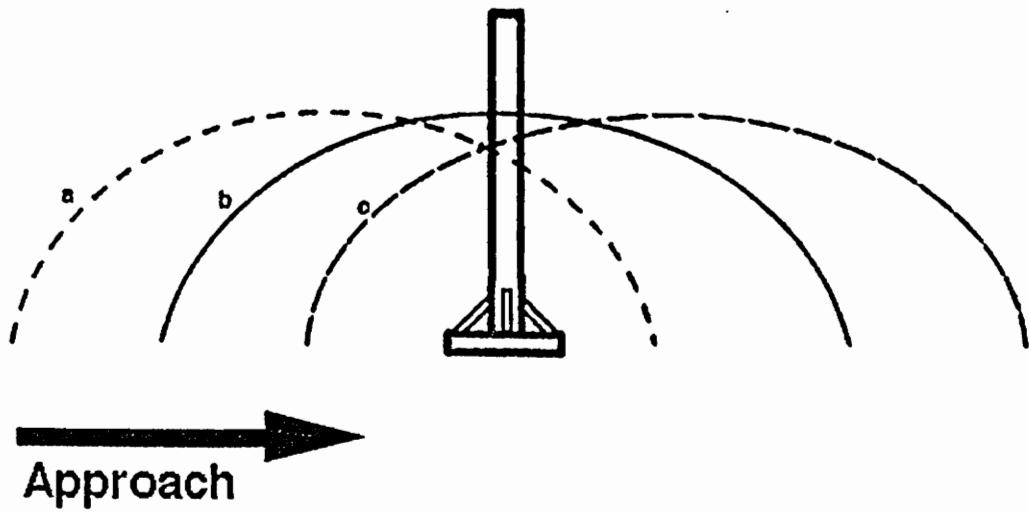

Figure 8. The different take-offs for a jump. Take-off "a" illustrates a long distance, "b" shows the ideal take-off, and "c" is referred to as a short or chip distance.

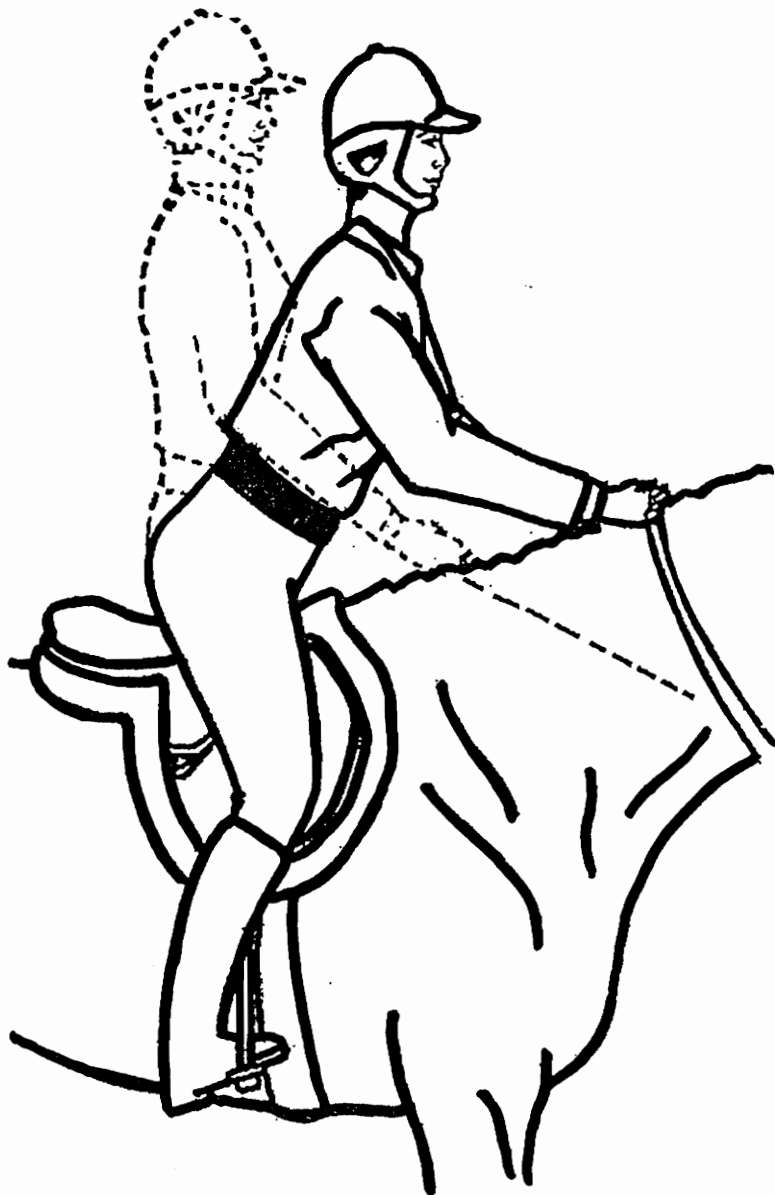

Figure 9. The dotted outline represents the correct vertical riding position. The dark outline is a demonstration of the crest release.

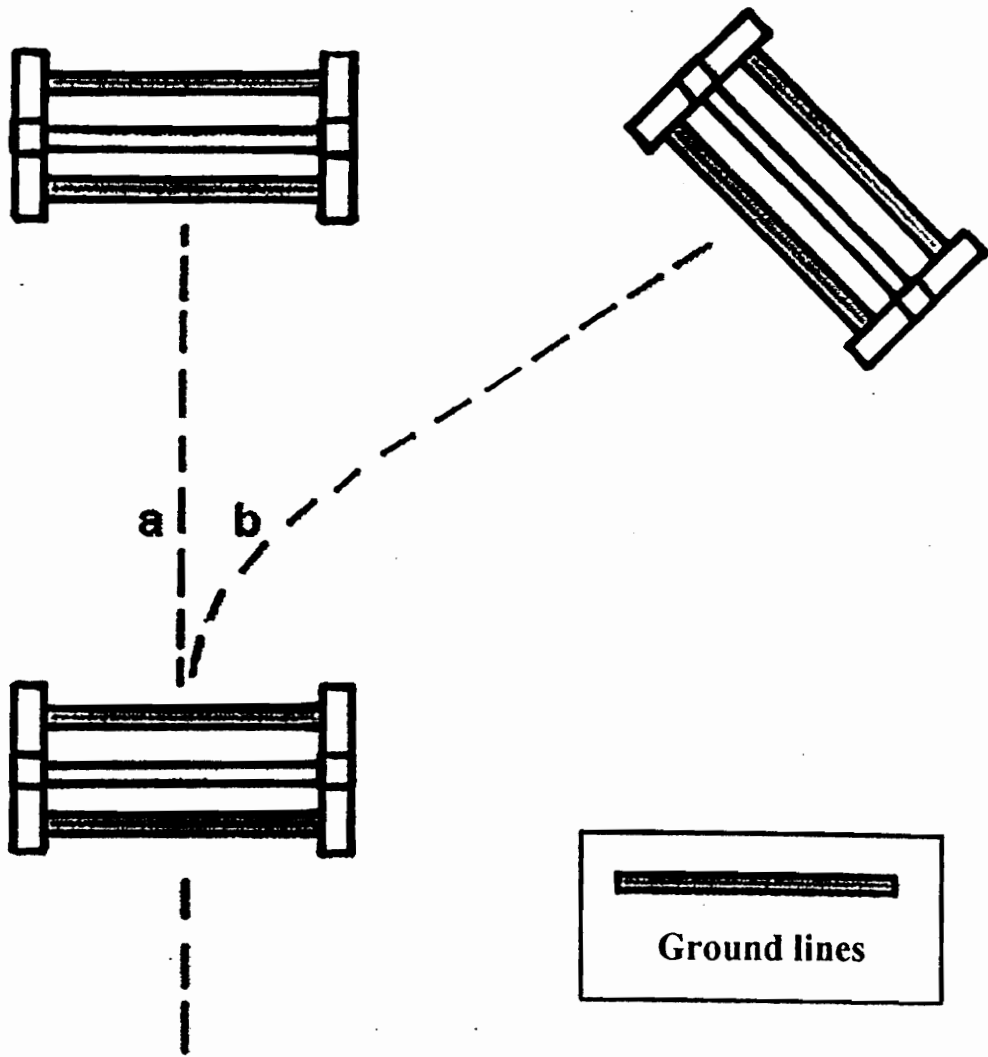

Figure 10. Illustrations of (a) a straight line, and (b) a bending line. The dark shaded poles are ground lines.

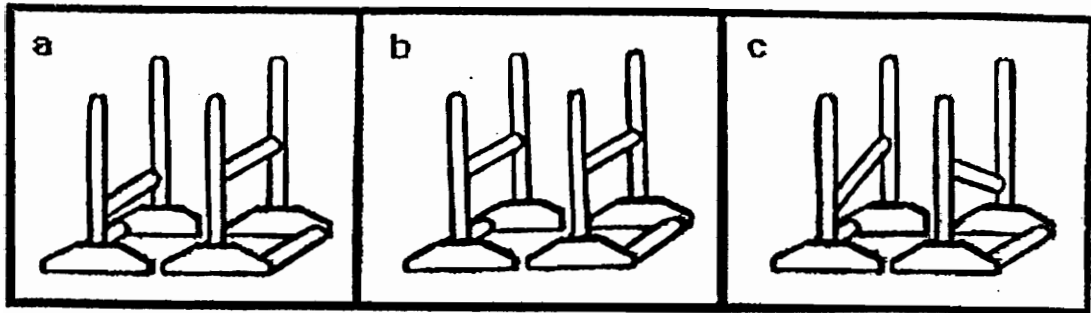

Figure 11. The set up of three oxers: (a) the ascending oxer, (b) the parallel oxer, and (c) the Swedish oxer.