

THE DESIGN AND CONSTRUCTION OF A VOLTAGE
STABILIZATION SYSTEM FOR A TWO MILLION
VOLT ELECTROSTATIC ACCELERATOR

by

George L. Ball

Thesis submitted to the Graduate Faculty of the
Virginia Polytechnic Institute
in candidacy for the degree of

MASTER OF SCIENCE

in

PHYSICS

APPROVED:

APPROVED:

Director of Graduate Studies

Head of Department

Dean of Applied Science and
Business Administration

Supervisor or Major Professor

December, 1956

Blacksburg, Virginia

TABLE OF CONTENTS

	Page
LIST OF TABLES	3
LIST OF FIGURES	4
INTRODUCTION	5
REVIEW OF LITERATURE	7
THE VOLTAGE STABILIZATION SYSTEM	10
The Magnetic Analyzer	12
The Slit System	15
The Amplification System	21
The Corona Assembly	32
OPERATION OF THE VOLTAGE STABILIZATION SYSTEM	40
Coordinated Function	40
Adjustments	41
Calibration	43
CONCLUSIONS	48
SUMMARY	49
BIBLIOGRAPHY	50
ACKNOWLEDGMENTS	52
VITA	53

LIST OF TABLES

Table		Page
1.	Amplification of D. C. Amplifier	46
2.	Tube Voltages During Calibration of the D. C. Amplifier	47

LIST OF FIGURES

Figure		Page
1.	Stabilization System Schematic Diagram	11
2.	Slit Box, Magnet, and Vacuum System	17
3.	Slit Box	18
4.	Sensitivity Adjustment Switch Circuit	22
5.	Amplifier Circuit	24
6.	Power Supply Circuit	27
7.	Amplifier Panel	28
8.	Corona Amplifier Circuit	29
9.	Corona Amplifier	31
10.	Corona Needle Assembly	33
11.	Corona Needle Assembly and Positioner	35
12.	Corona Amplifier and Needle Positioner	39
13.	Amplifier Calibration Curve	44

INTRODUCTION

Much research in nuclear physics is conducted with the use of a well-defined, monoenergetic beam of charged particles. Such a beam is used to bombard materials of which it is desired to learn the nuclear properties. A source of a charged particle beam, a two million volt electrostatic accelerator, is under construction at Virginia Polytechnic Institute, and is virtually completed.

To insure that particles of only one definite energy can reach the material under bombardment, there is need of an analyzing device in conjunction with the accelerator. This need is fulfilled by the use of a magnetic analyzer which separates the particles according to momentum. Its purpose includes also the refocusing of a slightly divergent beam of particles, causing an increase in intensity of the beam at the target.

Also of vital importance to the operation of an accelerator is a system for control of voltage. The potential of the high-voltage electrode is inherently fairly stable, due to accelerator design; but there do occur some drifts in potential, usually slow. These

voltage changes cause variations in particle energies, and consequently, the analyzer causes these particles of incorrect energies to be intercepted before reaching the target. The purpose of a system for voltage stabilization is to prevent such losses of the incident beam and permit maximum utilization.

Several requirements must be met by a voltage stabilization system. It must be sensitive to small voltage fluctuations and it must correct for them very quickly. It must be capable of restricting the maximum variation in voltage to a very small percentage of the total. All this must be accomplished without the loss of an appreciable portion of the beam current.

REVIEW OF LITERATURE

Any system for the stabilization of voltage requires three chief components. First, there must be an analyzer to detect any deviations in potential and give rise to an electrical signal. Second, an amplification system is required to strengthen that signal. Third, there is needed a control mechanism, activated by the amplified signal, capable of effecting any needed changes in the electrode potential.

In 1938, Parkinson, Bernet, Herb, and McKibben¹¹ devised a control system, using as the input the voltage derived from corona current from the high-voltage electrode to a needle projecting into the accelerator's pressure tank. This signal, amplified, was used to control the current in the primary of the transformer supplying a kenotron rectifier set. The rectifier supplied the high voltage for the belt-charging needles. This stabilizer was capable of holding the electrode potential constant to within about 0.5 per cent. Hanson⁸, in 1943, designed a similar system, the difference lying in the use of the detector plates of an electrostatic analyzer for the input signal. Due to the time required for

charge to travel on the belt to the electrode, there was a time lag of about one-sixth second between need of a potential correction and the actual correcting signal.

An investigation into the characteristics of grid-controlled corona was conducted in 1942 by Ashby and Hanson¹. The grid, a smooth plate with a small circular opening, had projecting through it a needle. The corona current was found to be approximately a linear function of grid potential. Using such a grid-controlled corona assembly, McKibben, Frisch, and Hush⁹, in 1946, achieved stabilization of voltage to within about 0.1 per cent, the corona assembly being used as a control mechanism. The input signal was obtained from a pair of slit jaws on an electrostatic analyzer. Response time was decreased to a few milliseconds. Fowler, Lauritsen, and Lauritsen⁷ reported on a similar system the following year.

Also in 1946, a voltage control system, using an electron gun, was devised by Bennett, Bonner, Mandeville, and Watt⁵. Insulated slit jaws, used in conjunction with a magnetic analyzer, served as a source of input signal. An electron gun, mounted at the base of the accelerating tube and aimed at the electrode,

provided a beam of electrons to effect voltage regulation. Due to the high velocities of these electrons, response time was about two microseconds. Relative variation was within about 0.3 per cent. One drawback of this system was an electron multiplication effect due to diverging electrons impinging upon the accelerating electrodes. This effect was overcome by Baume and Baggett³ who produced an electron beam of better definition and directed it through the center of the accelerating tube.

Bayse⁴, in 1951, described a system using a magnetic analyzer with pick-up plates and a corona assembly type of control. Banta² and associates, in 1955, constructed a stabilization system using a magnetic analyzer with slits, an exceptionally stable and sensitive direct current amplifier, and a combination type of control mechanism which effected electrode voltage stability by varying simultaneously belt-charging current, corona needle potential, and corona needle position with respect to electrode.

THE VOLTAGE STABILIZATION SYSTEM

The choice of components of a voltage stabilization system is based upon the stability requirements of the particular accelerator, its existing structural characteristics, the existing facilities for construction of the stabilizer, and the desire for structural simplicity. The V. P. I. accelerator is a horizontal, two million volt machine. It is planned in the future to convert it to a vertical installation and to double its present voltage. Plans for vertical installation dictated the use of an analyzer which would bend the beam of particles through a 90 degree angle. Such an analyzer, magnetic, double-focusing, of the circumferential yoke type, of a 16-inch radius, has been constructed.

The system chosen for voltage stabilization consists of the following components: an insulated slit assembly in conjunction with the magnetic analyzer, an amplification system of high gain, and a grid-controlled corona assembly. This system is well adapted to existing facilities, and has met with demonstrated success at the University of Kentucky⁴. Figure 1 shows a schematic diagram of this system.

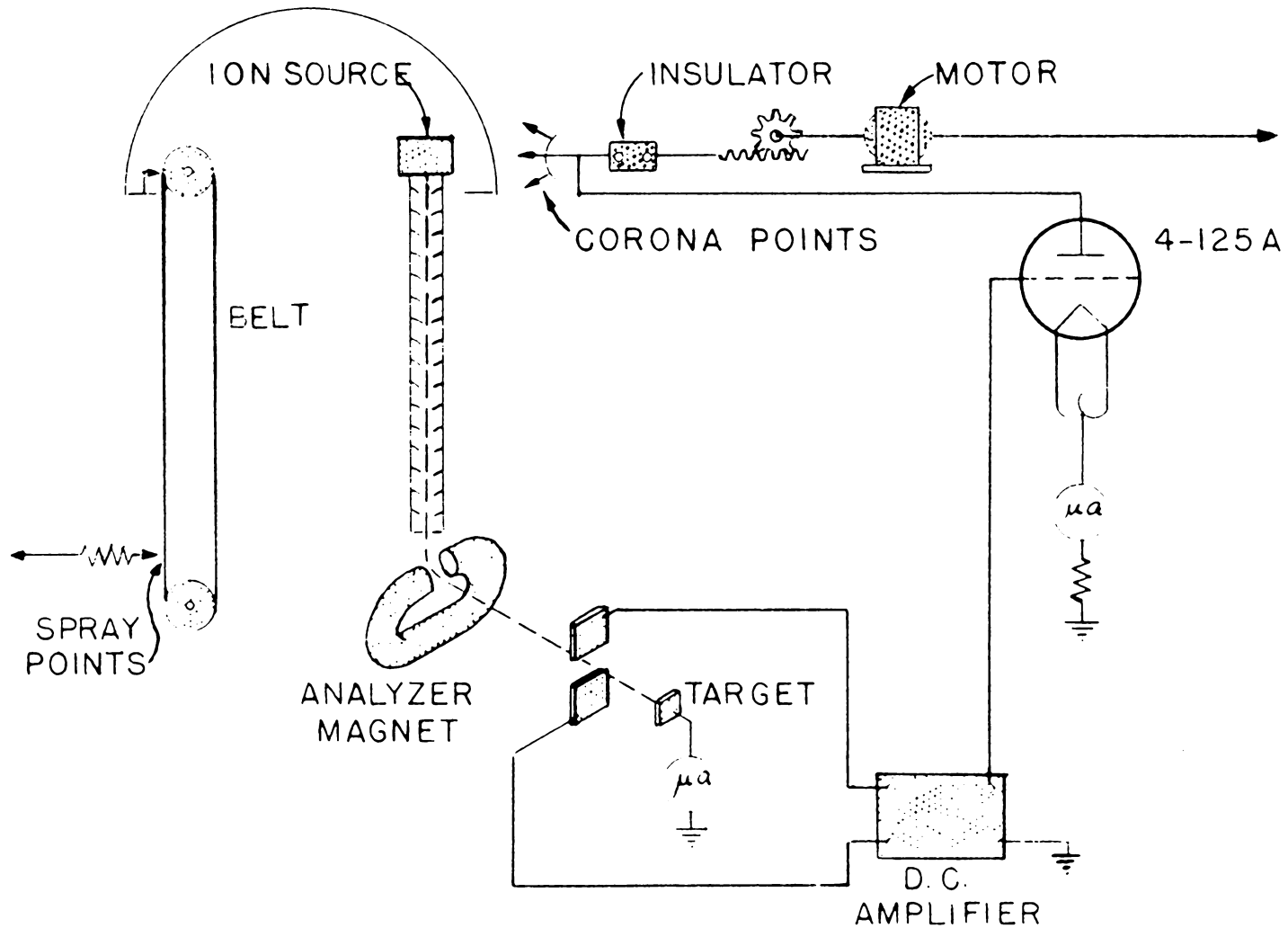

FIG. 1 STABILIZATION SYSTEM SCHEMATIC DIAGRAM

The Magnetic Analyzer

A charged particle moving in a magnetic field is subjected to a force at a right angle to its direction of motion. This force is balanced by the centrifugal reaction of the particle, as it undergoes a circular path of motion.

$$Bev = \frac{mv^2}{r}$$

where:

E is the magnetic induction in the air gap
of the magnet

e is the charge on the particle

v is the velocity of the particle

m is the particle's mass

r is the radius of the path of the particle

$$Ber = mv$$

$$E = \frac{1}{2} mv^2 = \frac{(Ber)^2}{2m}$$

where:

E is the energy of the particle.

These results show that the magnet serves as a momentum filter rather than as an energy filter since

the radius of the path is directly proportional to the momentum of the particle.

Stephens¹² has shown the following with regard to a magnetic analyzer of this type:

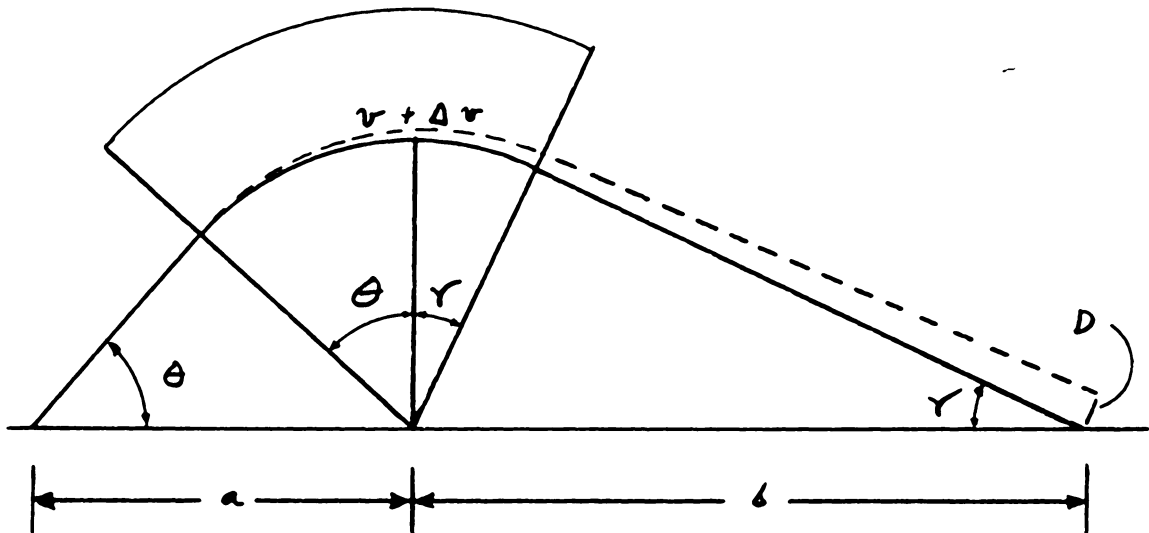

$$D = a (\sin \theta / \sin \gamma) (\Delta v / v) (\sin \theta + \sin \gamma)$$

For a 90 degree magnet of a 16-inch radius and focal length:

$$D = 2a \sin \theta (\Delta v/v)$$

$$E = 1/2 mv^2$$

$$\frac{dv}{v} = 1/2 \frac{dE}{E}$$

$$D = a \sin \theta \left(\frac{dE}{E}\right)$$

$$D = 16 \left(\frac{dE}{E}\right) \text{ inches.}$$

Thus, the linear dispersion of a particle at the focal point of the magnet is a function of the relative energy deviation. An effective detector of energy deviations can be constructed at this magnetic focal point. The detector consists of a pair of slit jaws acting as electrical pick-up plates. For a beam of normal energy, each jaw intercepts the same amount of current as the other, at the fringes of the beam. When electrode potential becomes too large, the slit jaw towards the outer circumference of the magnet will intercept more of the

beam than its mate, and vice versa. Thus, an electrical signal may be produced by passing the intercepted current to ground through resistors.

The Slit System

A slit system to be used in conjunction with the magnetic analyzer necessarily was designed with seven requirements in mind. First, the slit jaws must be insulated from each other and from ground. Second, the space around the jaws must be evacuated. Third, provision is needed for collimation as well as analysis of the beam. Fourth, adjustability is required. Fifth, there cannot be present any secondary emission resulting from the impingement of particles on the slit jaws. Sixth, the assembly should not be heavy and cumbersome. Finally, there is need of a viewing device to allow observation of the beam cross-section after collimation.

The design evolved from the above considerations embodies the use of a central block, with a circular channel along its longitudinal axis, on which are mounted the remaining elements. Ports extending from the exterior faces of the block to the inner channel accommodate the rods on which are mounted the slit jaws and viewer

assembly. The arrangement is such that a beam of particles, making passage through the evacuated chamber of the slit box, would have its horizontal fringes intercepted by a set of analyzing slit jaws and then its vertical fringes intercepted by a pair of collimating slit jaws, leaving the beam with a rectangular cross-section. This beam, if desired, may then be intercepted by the viewer or allowed to proceed directly to the target.

The central block was constructed of 2-s aluminum, is five inches by five inches in cross-section, and is seven inches in length. Its circular channel is two inches in diameter and is intersected at right angles by six circular ports with a diameter of $1\frac{3}{8}$ inches. Four of these ports, two mutually perpendicular pairs, accommodate the adjustable rods on which are mounted the slit jaws. Of the remaining two, one is used to accommodate the adjustment rod on which is mounted a quartz viewer, and the other is left unoccupied to serve as a viewing window.

In accordance with the need for adjustability, vacuum tightness, and electrical insulation of the slit components of this system, the rods holding the slit jaws were not mounted directly to the central block, but

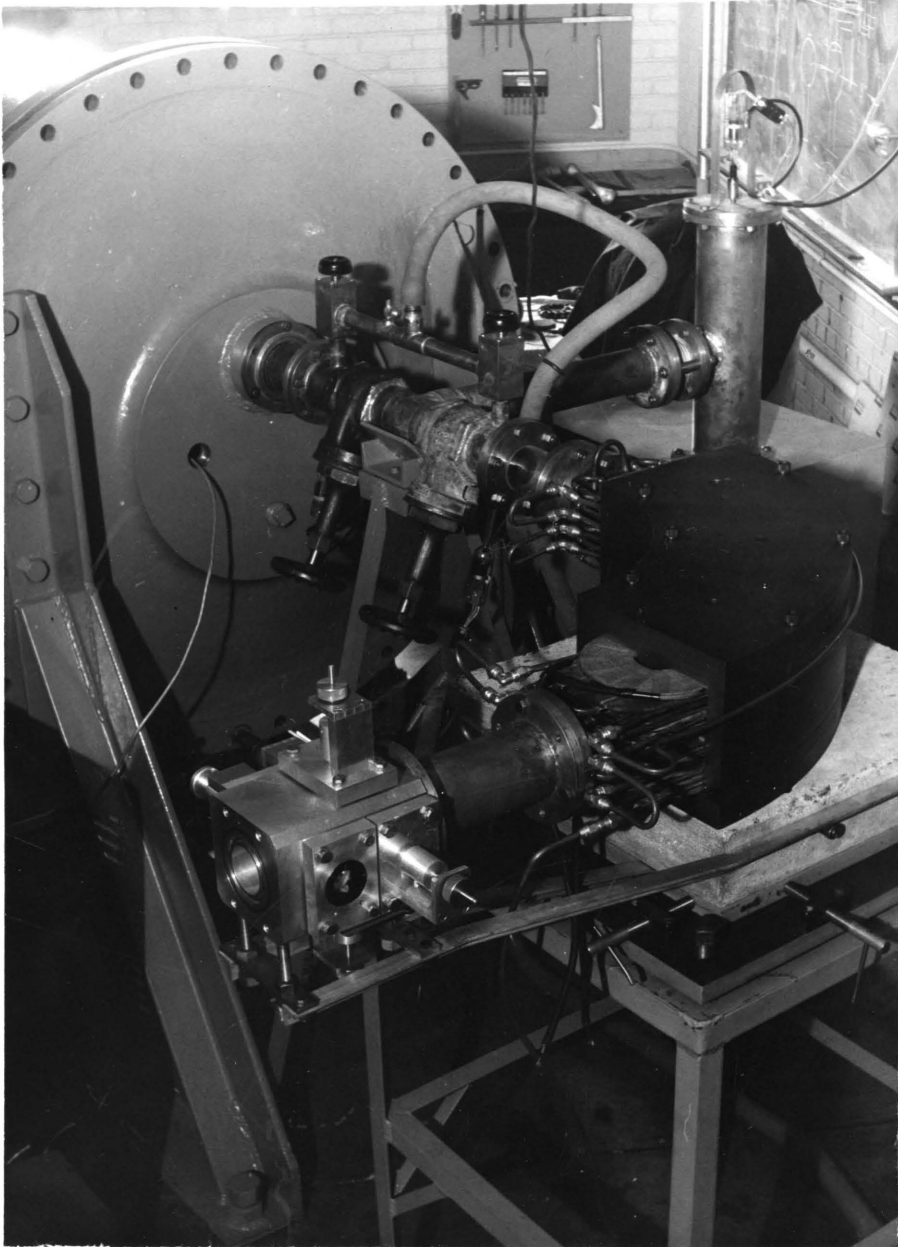

Fig. 2 Slit Box, Magnet, and Vacuum System

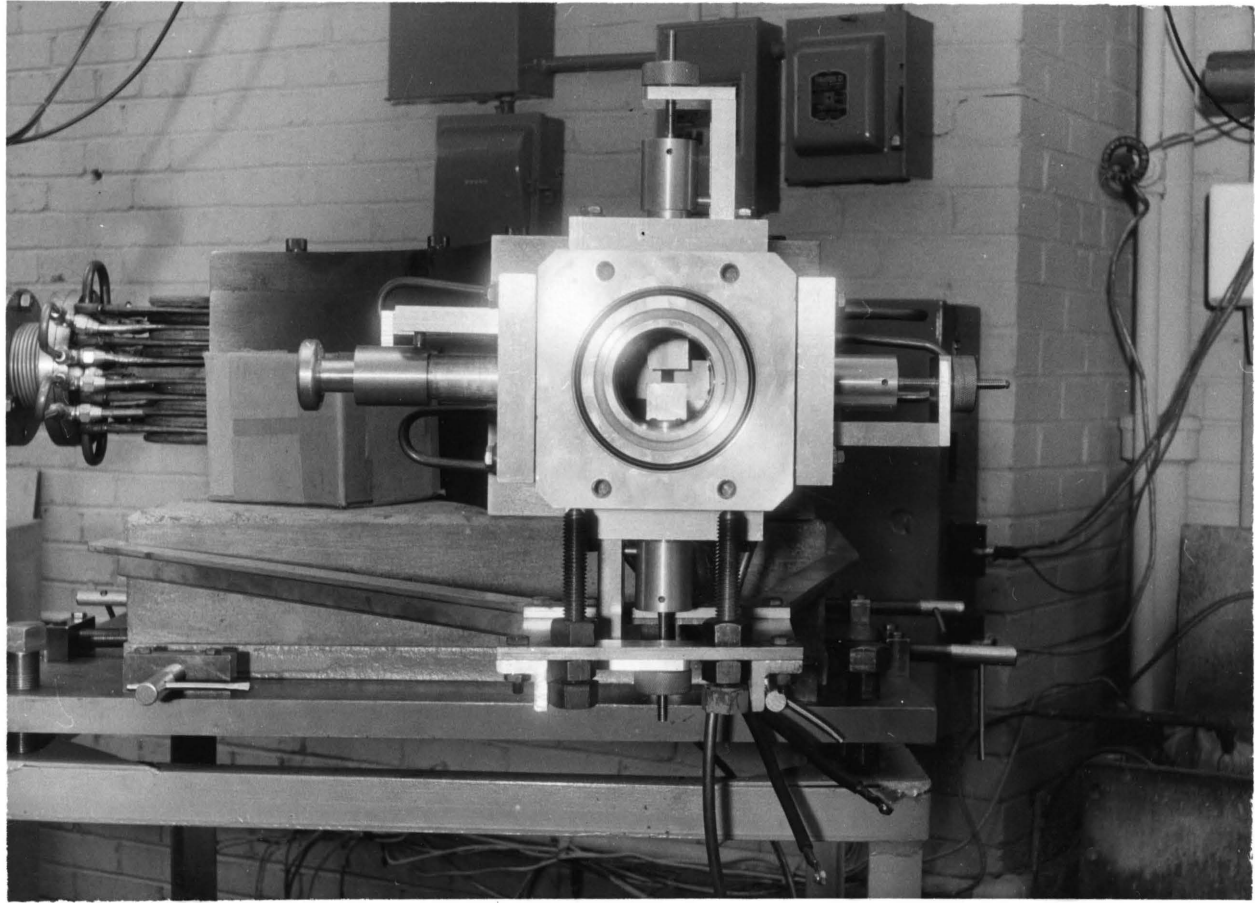

Fig. 3 Slit Box

were mounted to plates which are attached to the main block by bolts surrounded by insulating polystyrene bushings. There are vacuum tight o-ring seals between the plates and the block, and between the rods and the plates through which they are inserted. This latter o-ring assembly allows the rods to slide in and out against the o-ring seal, there being guides extending outward from each plate to insure a smooth sliding action and adjustment screws to facilitate easy manipulation. The range of adjustment of these rods is one inch allowing the slit jaws to be extended to the central axis of the block or to be withdrawn completely from the inner channel.

The slit jaws are detachable from their positioning rods in view of possible need of replacement. These jaws were made of tantalum, chosen for its high atomic number and the resulting absence of secondary electron emission and gamma emission when particles impinge upon them. Tantalum is characterized by hardness and a high melting point (2996 °C). It is unaffected by most acids, but forms a hydride in the presence of hydrogen, with subsequent flaking.

The rod which positions the quartz viewer was milled on its interior end so as to present a flat surface at an angle of 45 degrees to both the axis of the rod and the central axis of the inner channel. A disc of Vycor glass (96 per cent quartz and 4 per cent silica) of three-quarters of an inch diameter was mounted on this flat surface. When this disc is inserted into the path of the beam, it fluoresces under the bombardment enabling a person to view the cross-sectional beam through a port opposite that accommodating the viewer positioner rod. The exterior end of this port is covered by a disc of glass, sealed to the slit box with a very hard wax to insure vacuum tightness. The viewer rod is adjustable within a range of 1-1/2 inches, allowing it to be inserted into the path of the beam or retracted completely from the central channel.

The slit assembly was mounted with its analyzer slit 16 inches from the face of the magnet to correspond to the focal point. Coupling to the magnet and to the vacuum system was achieved by means of a flanged section of three-inch copper pipe, with o-ring seals at both ends of the pipe. A support for the slit assembly was fabricated from angle aluminum and mounted to the

supporting base of the magnet. Adjustment screws are included in the support platform to provide for alignment of the assembly in a horizontal plane and alignment with respect to the magnet. This alignment is not altered by adjustment of the position of the magnet.

The Amplification System

Connected between ground and each jaw of the analyzing slits is a large resistance. The charge from the intercepted portion of the beam is allowed to leak off through these resistors, and consequently, a difference in potential appears across each resistance. When one current becomes larger than the other, due to energy deviation in the beam, the potentials across the two resistances become unequal. Since it is desired to utilize these potentials as a signal input, an amplification system is necessary which can suppress the sum of these two positive input signals, but which will amplify the difference. A direct current amplifier which meets these requirements is represented in Figure 4. It was designed by Mr. Rutledge King at the High Voltage Laboratory of Oak Ridge National Laboratory².

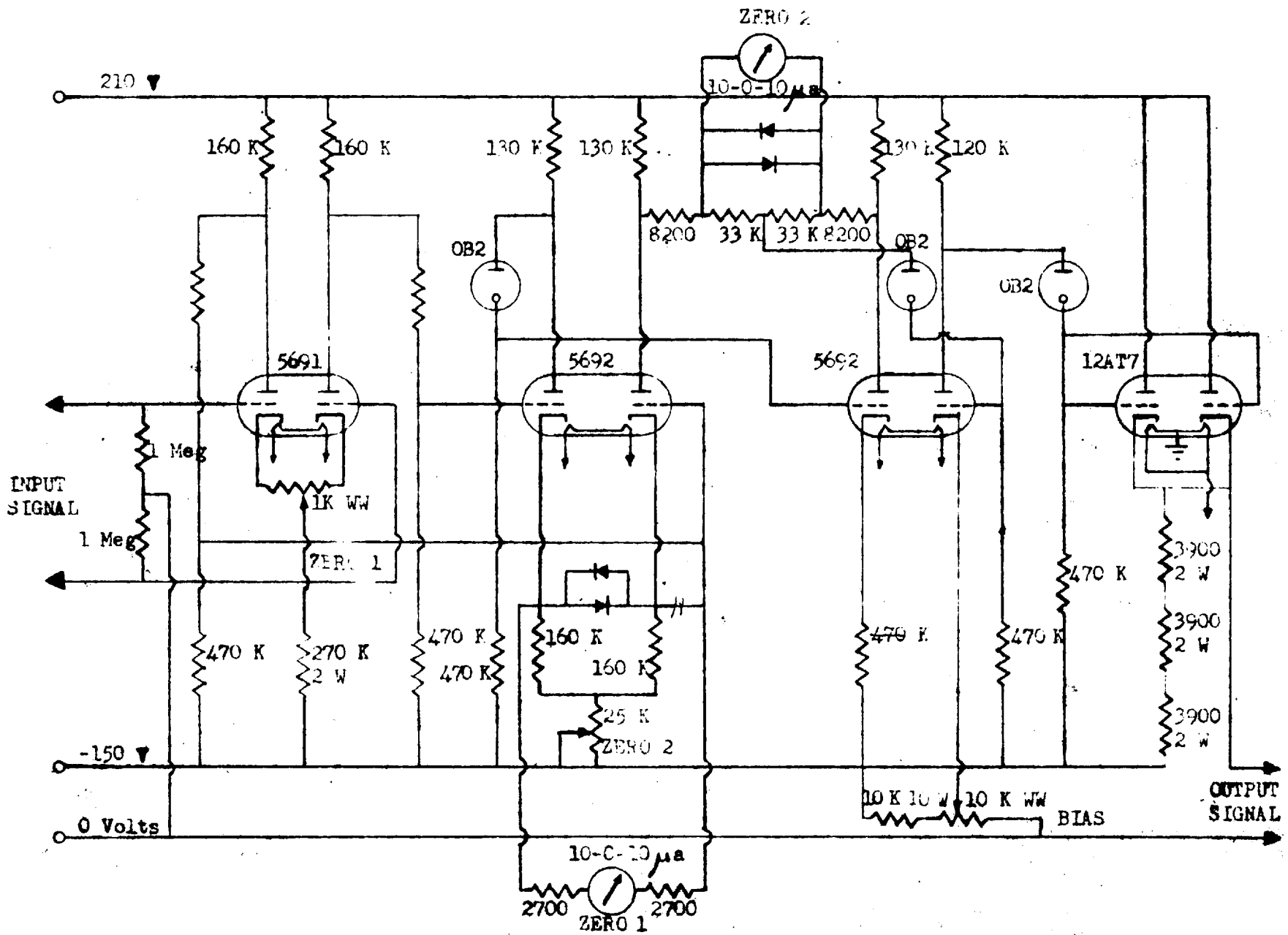

FIG. 4 D.C. AMPLIFIER CIRCUIT

To serve as a means for a variable input signal to the amplifier, a sensitivity adjustment switch was constructed. This switch contains eight resistance steps to compose the total resistance-to-ground for each analyzing slit jaw. Almost any desired fraction of the input potential can be used as a signal to the amplifier, there being a logarithmic variation in sensitivity from step to step. Each ascending step approximately doubles the sensitivity of the preceding one. A two-gang, nine-position rotary switch and precision resistors were utilized to construct this adjustment, the circuit for which appears in Figure 5.

The push-pull signal from the sensitivity switch serves as an input to the direct current amplifier. The first two push-pull stages serve as difference amplifiers. One plate of the second stage feeds a resistor chain directly; the other plate feeds the resistors through a phase inverter. A change in the magnitude of the beam current has no net effect on the output of this amplifier. Such a current variation causes identical changes at the plates of the second stage, giving rise to an increase in voltage at one end of the resistor chain and a decrease at the other. The

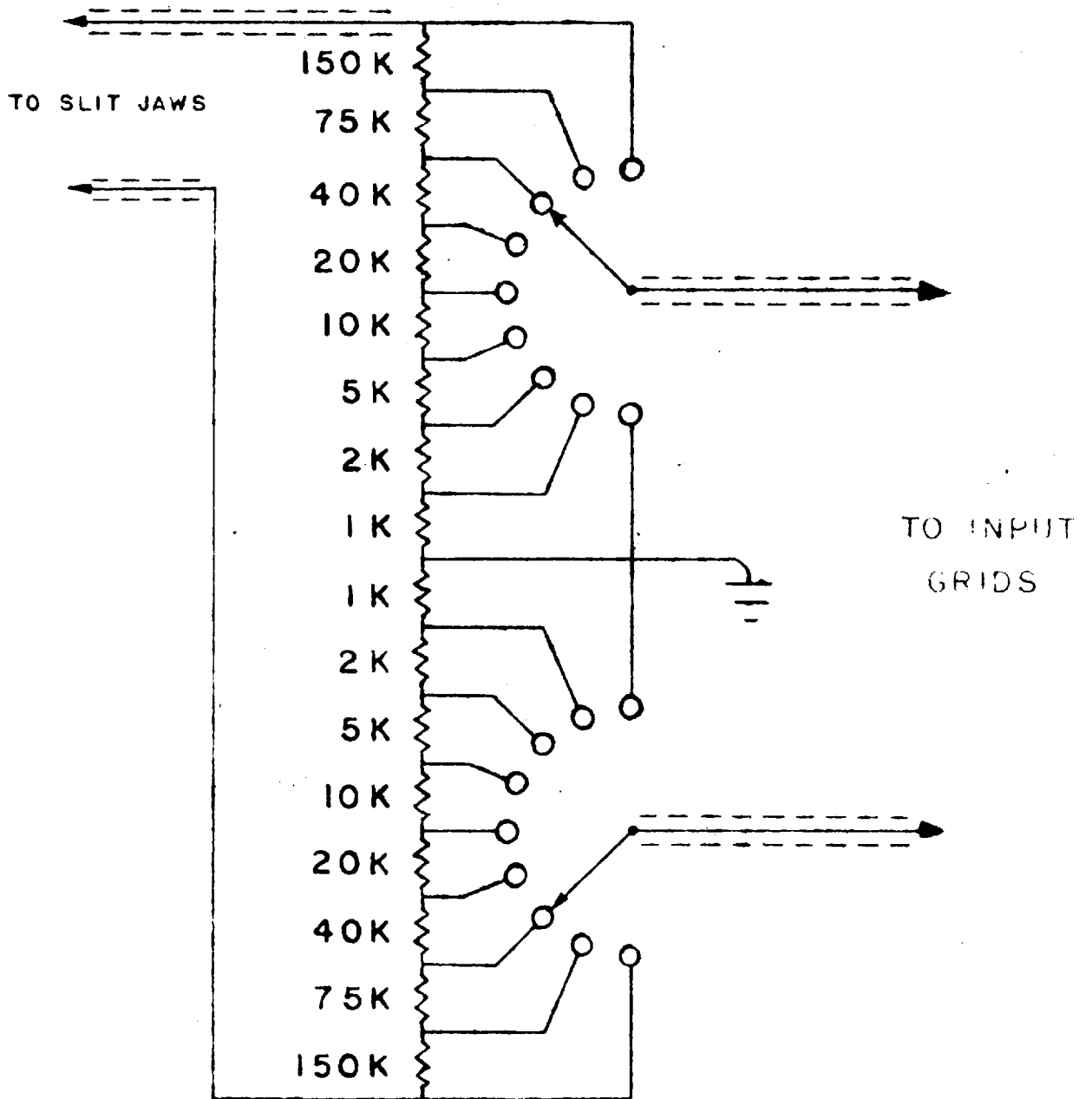

FIG. 5 SENSITIVITY ADJUSTMENT SWITCH CIRCUIT

voltage at the center is unaltered. When one slit jaw intercepts more beam current than the other, both plate voltages of the second stage change in the same direction, giving rise to a change in output voltage, directionally the same as the input signal.

Three potentiometer rheostate are included in this circuit for adjustment purposes. Two of these, labeled "Zero 1" and "Zero 2", in Figure 4, are used to balance the circuit so as to have no output signal in the absence of an input. Null readings on the two microammeters indicate a balanced condition. The third potentiometer is used to set a bias voltage on the output of the amplifier. The amplified signal is then superimposed on the bias voltage, a valuable feature in that this output is used to control the grid of a power tetrode (4-125A) which needs a grid bias.

An interesting feature of this circuit is the use of crystal diodes as variable shunts for the balance microammeters. A diode has high impedance at zero current; but at small currents the impedance is much lower. These non-linear elements produce an almost logarithmic meter response, allowing a protective extension in range

without the sacrifice of sensitivity as a null indicating device. All resistors used in the amplifier circuit are precise to within five per cent.

A stable, well-regulated power supply for this amplifier is necessary to the successful function of the entire system in achieving sensitive voltage control. Consequently, a circuit was designed using a π -section filter and a series of voltage regulator tubes to obtain quite stable operation.

The output of the direct current amplifier is not directly coupled to the control grid of the corona system; but it is used to control the grid of a 4-125A power tetrode, the plate of which is connected directly to the needles of the corona system. Added amplification and better regulation of corona current is achieved in this manner. The circuit of this corona amplifier is shown in Figure 8.

The plate voltage of the 4-125A power tetrode is that of the corona needles and is induced by the potential on the high-voltage electrode or dome. The electron current to the filament is directed through a resistor from ground. The potential across the resistor is used to operate an electronic microammeter, used

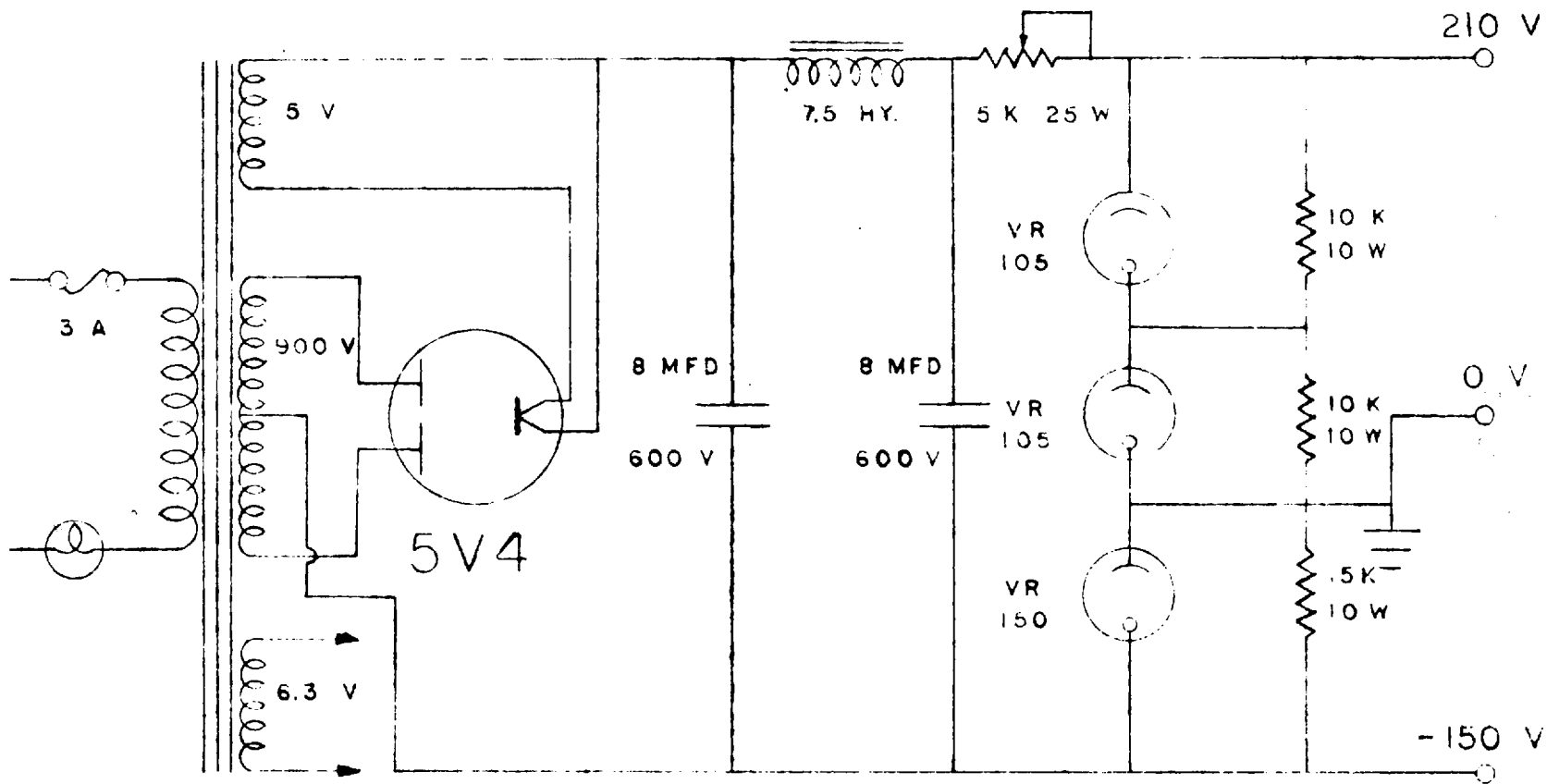

FIG. 6 POWER SUPPLY CIRCUIT

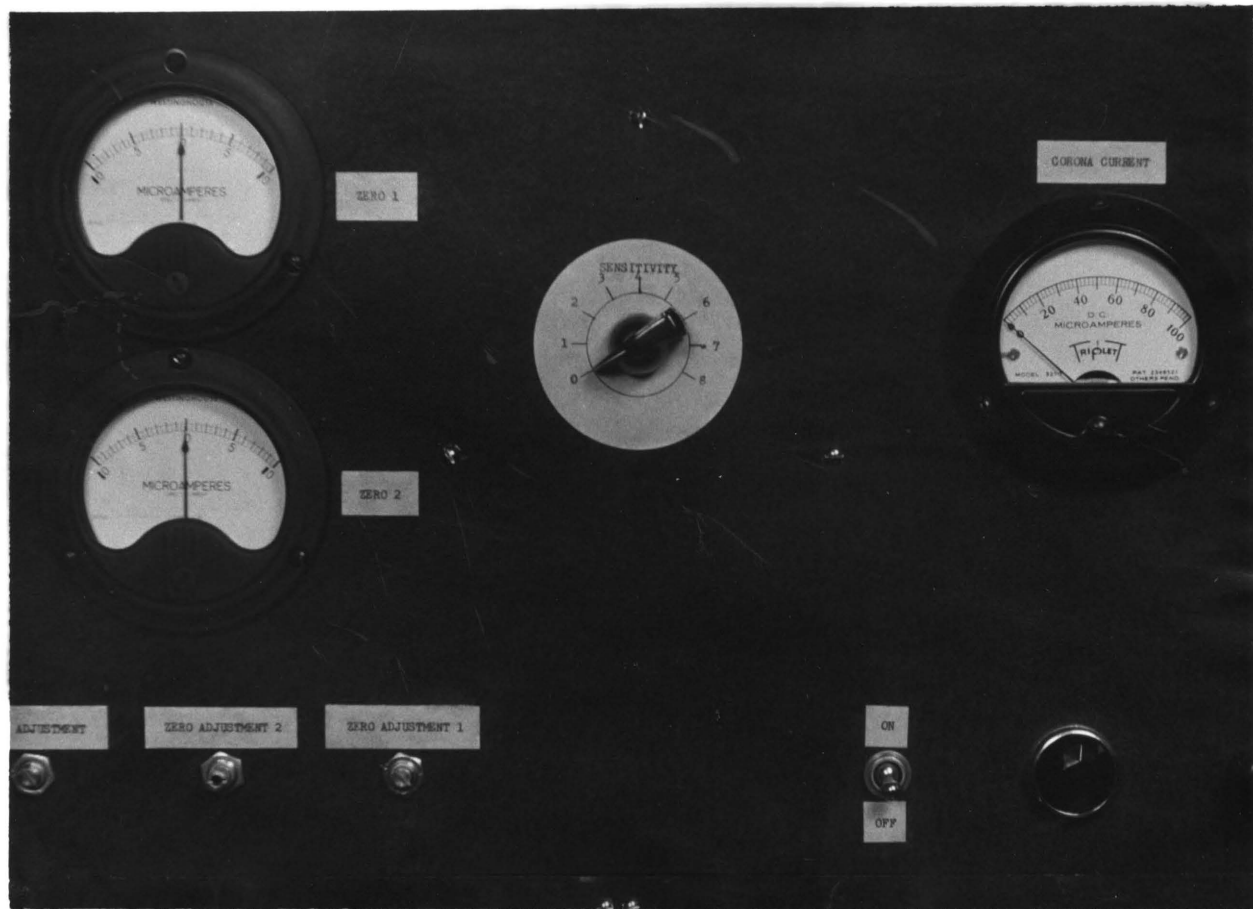

Fig. 7 Amplifier Panel

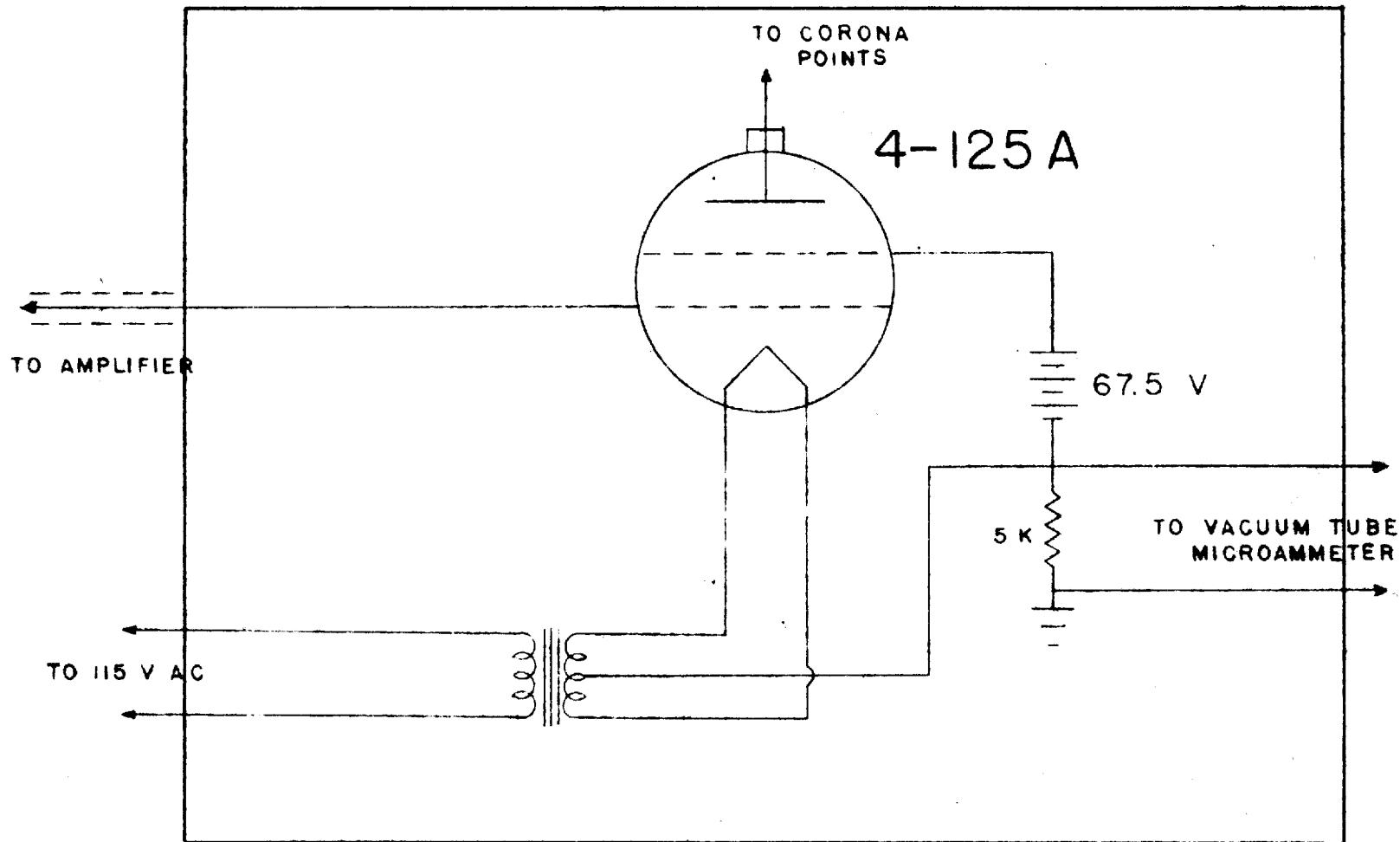

FIG. 8 CORONA AMPLIFIER CIRCUIT

instead of a conventional microammeter as current surges tend to damage the latter. The screen grid has a positive bias of $67\text{-}1/2$ volts, this value having been used successfully by Bayse⁴ at the University of Kentucky. The control grid, connected to the direct current amplifier, needs a negative bias of about $67\text{-}1/2$ volts, indicated also by Bayse. This bias setting can be made from the bias adjustment potentiometer on the direct current amplifier. A filament transformer is used to power the heater.

The direct current amplifier and its associated power supply were mounted in a cabinet in the accelerator control room, remote from the accelerator itself. The corona amplifier could not be mounted here due to the dangers to personnel presented by its high voltage; but it was necessary to construct a cabinet for it on top of the accelerator tank. The leads leaving the accelerator tank are isolated from any possible contact with high-voltage elements. The cabinet was perforated to allow a flow of air past the 4-125A power tetrode, allowing the rate of heat dissipation to be sufficiently high.

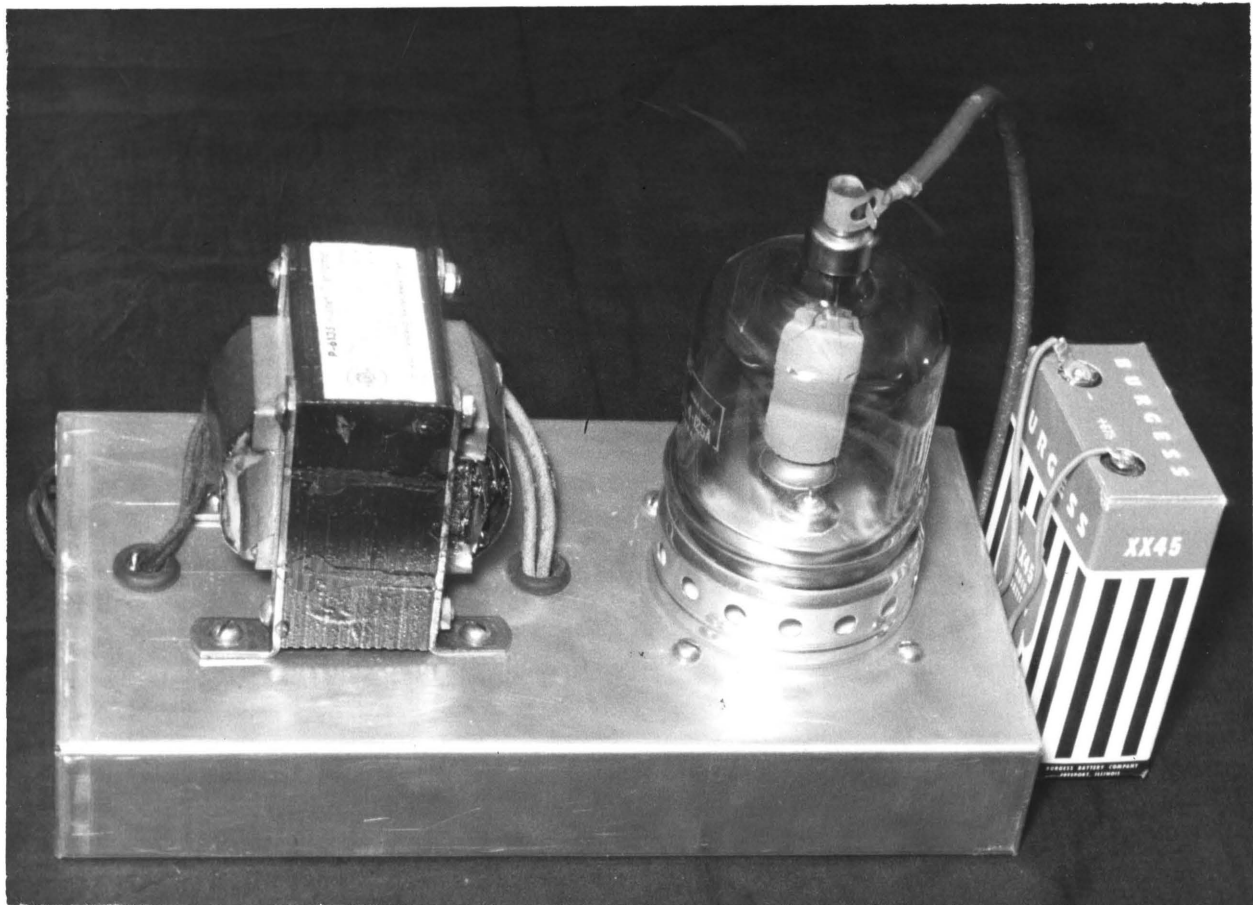

Fig. 9 Corona Amplifier

The Corona Assembly

The corona assembly, mounted within the accelerator tank by means of an insulating rod, has three chief elements, analogous to the elements of the triode. The high-voltage electrode is the plate of this "triode", the needles act as its cathode, and a grounded potential shield acts as the control grid. The needle assembly is pictured in Figure 10.

Two circular brass plates were utilized as a potential shield. These plates, 1/4-inch thick and of 4-1/2 inch diameter, are separated from each other at a distance of 2-1/8 inches by two brass supports. The plate nearest the electrode is perforated by a circle of five 1/2-inch holes, permitting the protrusion of five needles circularly mounted on a brass disc of a two-inch diameter. The brass disc is mounted on a fluted brass shaft which slides in and out of the insulating supporting rod to allow adjustment of the needle position with respect to the shield. Experimentation is needed to determine the optimum position of this adjustment; but the work of McKibben⁹ et al. suggests 1/4-inch protrusion of the needle tips as a feasible value. All parts are polished to minimize the occurrence of corona



Fig. 10 Corona Needle Assembly

discharge from any points other than the ends of the needles.

The function of the grounded plates is to control the electrostatic field in the vicinity of the needles. They cause intensification of the field at the tips of the needles and prevent discharge from other parts of the assembly. Although the shielding plate is grounded, it still serves as a grid in the same manner as did the grid in the experimental arrangement of Ashby and Hanson¹. The magnitude of the corona current is dependent upon the potential difference between the grid and the needles.

The position of the needles with respect to the electrode sometimes needs to be varied, each operating electrode potential having a corresponding optimum needle position. A positioning device was constructed for the needle assembly, capable of placing the needle points at any distance from the dome within the range of 3-1/4 to 8-1/2 inches. The positioner, mounted on the top of the pressure tank, was designed to be powered by a small reversible capacitor motor to be operated remotely, from the accelerator control room.

The rod supporting the corona assembly was mounted with a vertical degree of freedom, allowing its use as a

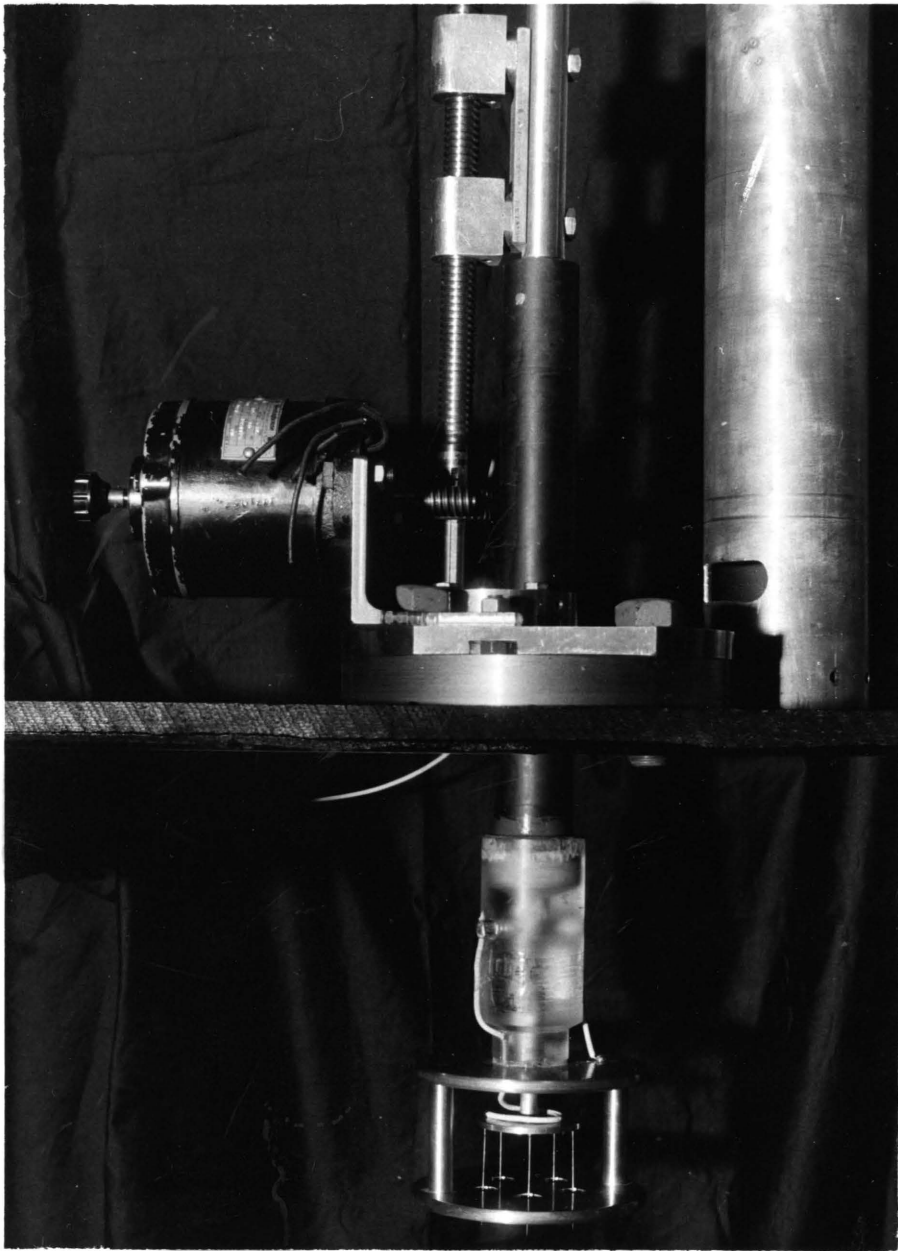

Fig. 11 Corona Needle Assembly and Positioner

positioner rod. This rod slides against an o-ring pressure seal contained in a steel flange covering a three-inch circular port in the top of the tank. The exterior end of this rod is connected to the positioner assembly.

The positioner utilizes a vertically mounted worm drive screw attached by means of two sturdy brass nuts to the positioning rod. Rotation of this drive screw effects vertical translation of the support rod, and of the inner corona assembly. The drive screw is mounted within a 3-1/4 inch copper pipe projecting from the top of the tank. Brass plates at either end accommodate roller bearings to facilitate smooth rotation of the drive screw. This rotation is achieved by use of a gear, mounted near the lower end of the drive screw shaft. The gear is turned by another worm drive screw mounted on the shaft of the motor. The gear ratio is such that, while the motor operates at 1800 r.p.m., the speed of translation of the corona needle assembly is seven inches per minute. Microswitches were utilized to limit the extent of translation of the system.

The rod supporting the corona assembly was fabricated from three sections. The portion sliding through the pressure seal was turned from a thick-walled

bakelite pipe (inside diameter, 1/2-inch; outside diameter, 1-1/2 inches). Threaded into the upper end of the bakelite pipe is a short brass rod, used to connect to the nuts on the worm drive screw. Threaded onto the lower end of the pipe is a short lucite section, which has threaded on it the corona assembly.

The purpose of such a three-piece fabrication was to allow the installation of electrical leads to the corona assembly without the use of special pressure seals at their points of entrance into the tank. With this arrangement the two leads needed were connected through the interior of the rod, two pressure seals being constructed in the lucite section. These seals consisted of two threaded brass plugs, with the electrical leads soldered to either end of each. These plugs were threaded into two holes in the lucite, bored from the exterior to meet at right angles another hole, through half the length of the lucite section, aligning with the opening in the lucite pipe.

One electrical lead was used to connect the set of needles to the plate of the power tetrode. The other served to ground the control grid of the corona assembly through a microammeter.

The entire corona and positioning assembly was constructed quite sturdily, in view of the magnitude of the forces involved when the tank is pressurized with 200 psi of nitrogen.

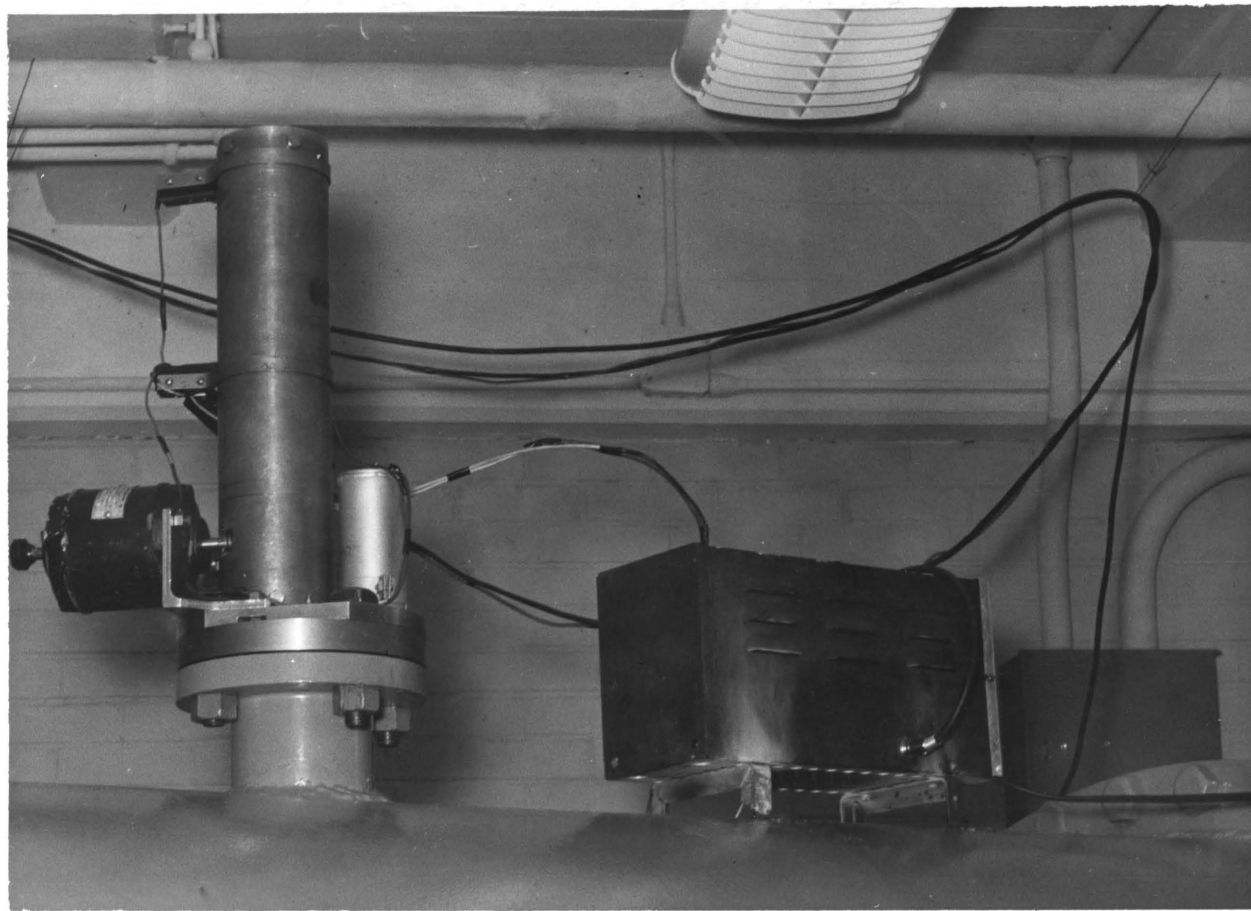

Fig. 12 Corona Amplifier and Needle Positioner

OPERATION OF THE VOLTAGE STABILIZATION SYSTEM

Coordinated Function

In order to clarify the operation of the entire stabilizer system, the effects of a sample variation in electrode potential will be traced throughout the system. Suppose that the electrode of normal voltage experiences an increase in potential. A beam of positive ions departing from the electrode will acquire an additional increment of energy and momentum. In passing through the magnetic analyzer this beam is subjected to a slightly smaller deviation than is normal. The slit jaw nearest the outside circumference of the magnet intercepts more of this beam than does the one opposite. The electrical input to the amplifier from this jaw is more positive than the input from the other. The difference between them is amplified by the direct current amplifier. The output of the amplifier becomes more positive, as does the grid on the power tetrode. This increase in grid potential allows an increased current through the tetrode, effecting a decrease in the potential of the corona needles. The grounded grid, being

more positive with respect to the needles, allows an increased corona current. The increased corona current causes lowering of electrode potential, the desired result. The entire operation requires a few milliseconds, the time needed for electrons, freed from nitrogen atoms by ionization, to traverse the distance to the electrode.

Performance characteristics of the entire control system cannot be reported, as the accelerator was not completed at the time of this writing. However, fairly complete information is reportable on the operational procedure for each of the components.

Adjustments

The slit system requires adjustment according to the amount of beam current it is desired to intercept for analysis and collimation. This adjustment has been facilitated by the construction of knurled adjustment screws. The viewer assembly allows observation of the slit jaw positions with respect to the beam and each other.

Regulation of the magnitude of the signal input to the amplifier may be achieved by means of the

sensitivity adjustment switch mounted on the amplifier panel. Proper switch positions can be determined by analysis of control capability for each position, with a constant magnitude of the intercepted beam current.

Amplifier balance is conveniently accomplished.

The sensitivity adjustment switch is turned to the position marked "0", grounding each of the two input grids. Then the potentiometer rheostats, marked "Zero Adjustment 1" and "Zero Adjustment 2", should be adjusted until null readings appear on both the balancing microammeters. This adjustment should be made after the amplifier has warmed up for about an hour. This time allows the circuit elements to attain a steady temperature without which a balanced condition cannot be long sustained.

The 4-125A power tetrode used as a corona amplifier will undergo a voltage breakdown if its plate potential is allowed to exceed 3000 volts. The induced potential on this plate is a function of the needle position. Hence, the plate potential of the tetrode may be regulated by use of the corona needle positioner. A change in the operating voltage of the electrode will usually necessitate a change in the position of the

corona needles, so as to keep the plate voltage within a limit of 3000 volts. The operator will have indication of the need for position changes in the form of readings on an electronic microammeter which reads the value of the corona current. When the current reading becomes small, the needles must be moved closer to the electrode; when the reading reaches some maximum value, to be determined, the corona needles must be withdrawn.

Position adjustment of the corona needles with respect to their control grid may be desirable at some time. This must be done manually from the interior of the tank.

Calibration

A calibration curve was plotted for the amplifier (see Figure 13) showing an approximately linear response over a wide range of inputs. Saturation effects are shown for input voltages far exceeding any that the amplifier should ever encounter under normal operating conditions. The calibration was performed using a voltage divider to produce two positive inputs. A sensitive potentiometer was used to measure the difference between the two input voltages. The output was

FIG. 13 AMPLIFIER CALIBRATION CURVE

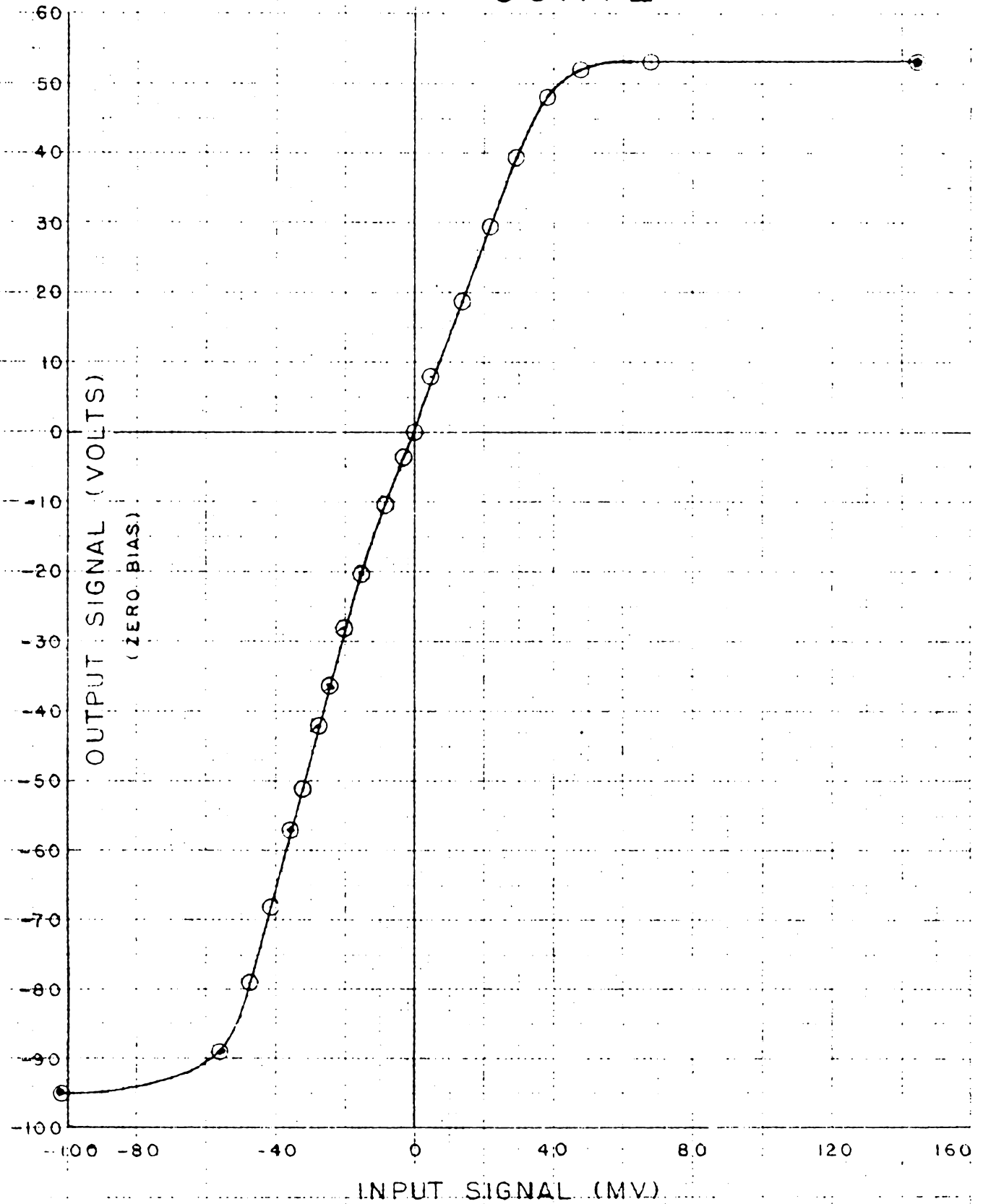

measured with an electronic voltmeter. Tabulation of approximate amplification factors for various input voltages appears in Table 1. Also tabulated (see Table 2) are the voltages of the tube elements during calibration.

Tests on the voltage-regulated power supply showed it to have a ripple in the voltage output of 0.005 volt for an output of about 200 volts. This ripple voltage agreed with the calculated value.

TABLE 1

Amplification of D. C. Amplifier

Input (mv)	Output (volts)	Approximate Amplification Factor
4	5.5	1400
8	11.0	1400
12	16.0	1300
16	21.5	1400
20	27.0	1400
24	32.5	1400
28	37.5	1300
32	42.5	1300
36	46.5	1000
40	49.0	650
44	51.0	500
48	52.0	250
52	52.5	120
56	53.0	120
60	53.0	0

TABLE 2

Tube Voltages During Calibration
of D. C. Amplifier

Tube Element	5691		5692		5692		12AT7	
	A	B	A	B	A	B	A	B
Grid	0	0	13	12	-38	-20	-2.8	-2.8
Plate	116	117	71	89	89	103	207	207
Cathode	1.5	1.5	15	15	-32	-14	0	0
No input signal			Bias Voltage - 0 volts					
Grid	0	0	13	12	-38	-20	-85	-85
Plate	116	117	71	89	89	21	207	207
Cathode	1.5	1.5	15	15	-33	-19	-81	-81
No input signal			Bias Voltage - -81 volts					

CONCLUSIONS

Performance tests on the voltage control system were necessarily incomplete. However, calibration tests on the direct current amplifier, the most critical component in the system, showed it to be completely satisfactory. Mechanical operation of the slit box adjustments and the corona assembly positioner has been observed to be excellent. Components of basically the same type have been used satisfactorily in other experimental facilities. Therefore, it is expected that this stabilization system will be completely adequate to obtain high energy resolution suitable for all experimental work to be conducted with the V. P. I. electrostatic accelerator.

SUMMARY

A voltage stabilization system, utilizing corona feedback, has been designed and constructed for the two million volt electrostatic accelerator at Virginia Polytechnic Institute. An aluminum slit assembly using tantalum slits collimates the particle beam and analyzes it according to energy. The signal received from the slit jaws is electronically amplified and fed to a corona discharge system inside the pressure tank of the accelerator. The electrode voltage of the accelerator is stabilized by an automatic change in the corona current when fluctuations occur in beam energy.

Calibration of the amplifier has demonstrated its linearity and adequacy. Mechanical operation of the slit and corona assemblies has been found to be quite satisfactory. Final tests of the energy stabilization of this system are expected to show a response time of the order of a few milliseconds and an energy resolution of about one-tenth of one per cent.

BIBLIOGRAPHY

1. Ashby, R. M., and Hanson, A. O., Rev. Sci. Inst., 13, 128 (1942)
2. Banta, H. E., Control of High Voltage Equipment Used in the Acceleration of Positive Nuclear Particles, ORINS Lecture (1955)
3. Bame, S. J., Jr., and Baggett, L. M., Rev. Sci. Inst., 20, 839 (1949)
4. Bayse, C. A., Voltage Stabilizer of the Van de Graaf Generator, Unpublished M. S. Thesis, Univ. of Ky. (1951)
5. Bennett, W. E., Bonner, T. W., Mandeville, C. E., and Watt, B. E., Phys. Rev., 70, 882 (1946)
6. Buechner, W. W., Van de Graaf, R. J., Sperduto, A., McIntosh, L. B., and Burrill, E. A., Rev. Sci. Inst., 18, 754 (1947)
7. Fowler, W. A., Lauritsen, C. C., and Lauritsen, T., Rev. Sci. Inst., 18, 818 (1947)
8. Hanson, A. O., Rev. Sci. Inst., 15, 57 (1944)
9. McKibben, J. L., Frisch, D. H., and Hush, J. M., Phys. Rev., 70, 117 (1946)

10. Oliver, D. W., The Design and Construction of a Magnetic Analyzer, Unpublished M. S. Thesis, V. P. I. (1956)
11. Parkinson, D. B., Bernet, E. J., Herb, R. G., and McKibben, J. L., Phys. Rev., 53, 642 (1938)
12. Stephens, W. E., Phys. Rev., 45, 513 (1934)
13. Van de Graaf, R. J., Trump, J. G., and Buechner, W. W., Reports on Progress in Physics, XI, 1 (1948)

ACKNOWLEDGMENTS

The author wishes to express his deepest gratitude to the many members of the Physics Department faculty who assisted in the research and writing of this thesis. He wishes, especially, to thank Drs. Andrew Robeson and T. M. Hahn, Jr., for guidance, assistance, encouragement, and inspiration in this project. To Dr. L. August, Mr. W. Richardson, and Mr. J. L. Ryan, the author would like to express appreciation for frequent helpful suggestions and assistance. He, also, is indebted to Mr. L. Barnett for much aid in the construction of the apparatus.

The author gratefully acknowledges the donation by the Reynolds Metals Corporation of the aluminum used in the slit assembly. Finally, the author wishes to extend his sincere thanks to _____ for her great care in the typing of this thesis.

**The vita has been removed from
the scanned document**