

(a) Initial and optimized twist and dihedral distributions.

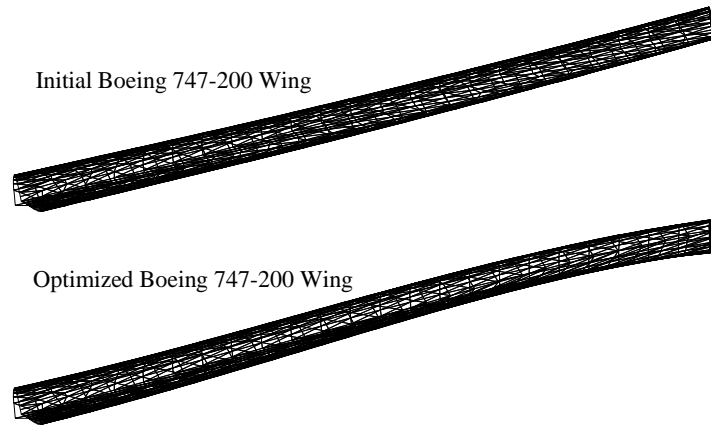

(b) Upstream view of the surface mesh on the outboard wing stations.

Figure 6.16: Optimization results for the Boeing 747-200 wing redesign.