

# **An Educational VSAT System for Thailand**

by

Kanokporn Kunchaicharoenkul

Thesis submitted to the Faculty of the  
Virginia Polytechnic Institute and State University  
in partial fulfillment of the requirements for the degree of  
Master of Science  
in  
Electrical Engineering

APPROVED:



Timothy Pratt, Chairman

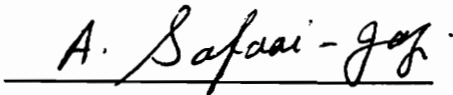

Ahmad Safaai-Jazi

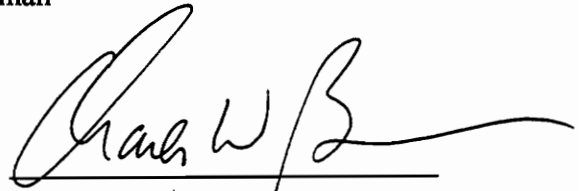

Charles W. Bostian

September 1996

Blacksburg, Virginia

**Keywords:** Very small aperture terminal (VSAT), Education, Satellite, Thailand

LD  
5655  
V855  
1996  
K863  
c.2

# **An Educational VSAT System for Thailand**

by

Kanokporn Kunchaicharoenkul

Committee Chairman: Timothy Pratt

Electrical Engineering

(ABSTRACT)

Very small aperture terminal (VSAT) networks offer great opportunities to combine satellite technology and the needs of education in Thailand. An educational VSAT network for Thailand needs a central hub station in Bangkok and seven remote sites with VSAT equipment. The network supports two way compressed video, voice and data links between the central hub and VSAT sites.

This thesis examines rain margin, system availability, VSAT antenna size and transponder power utilization in an educational VSAT system using Ku-band. Demand assignment multiple access (DAMA) and single channel per carrier (SCPC) transmission techniques work well for multiple access purposes and minimizes the cost of the space segment. The moving picture expert group-2 (MPEG-2) system is the best choice of compression system in this design.

The final performance analysis shows that with the THAICOM-1 satellite and 2-Watt VSAT transmitters, and 1.8m or 2.4m VSAT antennas, VSAT-to-hub links can be established using the full transponder power with significant rain margins. Typical outage times for this system are 98.5% for the hub-to-VSAT links and 95.0% for the VSAT-to-hub links.

## Acknowledgment

I am sincerely grateful to Dr. Timothy Pratt for serving as my advisor and providing me with a very interesting topic for my thesis. Without his guidance and patience, the undertaking and completion of this thesis would not have been possible. He was always willing to share his valuable time to teach me how to conduct this study and always there to help me through these rough years. There are no words to express the extent of my appreciation for all knowledge and expertise he has contributed. I would like to thank the members of my committee, Dr. Ahmad Safaai-Jazi and Dr. Charles W. Bostian, for their helpful comments and suggestions.

I further thank, Sanei Saiwong and Sombat Sereesupukkul for providing me very useful information from Thailand. Most importantly, I would like to thank Shinawatra Computer and Communications Group (SC&C) for giving me the opportunity and resources to fulfill my goals.

Special thanks go to my dearest brother, Sarat Chatirung, for his valuable help and providing his computer to write this thesis. Without his help, this work would never come to pass.

My stay at Virginia Tech would not have been completed without my wonderful friends: Aarti Khanna, KengJin Lian, Sirasak Teparkum, Krit Poonsirivong, Warangkana Punrattanasin, Pantipa Phayak and most importantly Voravut Suppanitchakij.

I am especially thankful to Umphol Lohtrakoolwat for his love, encouragement and understanding throughout the past eight years.

Finally, I would like to thank my dear family, without whom I would not be where I am today. I dedicate this thesis to my parents, sisters and brothers; Vichai, Nittaya, Pravit, Sudarut, Pimonrut and Theeraput, for providing constant encouragement via long-distance telephone calls from Thailand during the writing of this thesis.

# Table of Contents

- 1. Introduction.....1**
- 2. Background.....5**
  - 2.1 A History of Satellite Communications in Thailand.....6
  - 2.2 THAICOM: Thailand’s first national communications satellite project.....7
    - 2.2.1 Launching THAICOM into Orbit.....9
    - 2.2.2 Technical Description of THAICOM.....10
    - 2.2.3 Details of HS-376 THAICOM Satellite.....11
  - 2.3 Proposals for a VSAT Educational Network in Thailand.....13
- 3. Propagation in Thailand.....15**
  - 3.1 Thailand in Tropical Climate.....15
  - 3.2 Global & CCIR Model for Tropical Climate.....17

|           |  |           |
|-----------|--|-----------|
| 3.3       | The Climate of Thailand.....   | 21        |
| 3.4       | Rain Attenuation in Thailand.....                                      | 21        |
| 3.4.1     | Attenuation Calculation.....   | 22        |
| 3.4.2     | Attenuation Results.....   | 26        |
| <b>4.</b> | <b>Educational Networks using VSAT System.....</b>                     | <b>34</b> |
| 4.1       | Introduction.....  | 34        |
| 4.2       | Mitsubishi VSAT Educational Network.....                               | 36        |
| 4.2.1     | Features .....   | 36        |
| 4.2.2     | Network Configuration.....   | 38        |
| 4.3       | An Existing Educational VSAT System in Spain.....                      | 39        |
| 4.4       | Satellite TV System of Virginia Tech.....                              | 41        |
| 4.5       | Comparison of The Educational Network Systems.....                     | 42        |
| <b>5.</b> | <b>THAICOM-1: Education VSAT Network Design.. .....</b>                | <b>43</b> |
| 5.1       | THAICOM-1 VSAT Educational Network Design Considerations.....          | 43        |
| 5.2       | The THAICOM-1 Educational VSAT System .....                            | 47        |
| 5.2.1     | SCPC DAMA Network .....  | 48        |
| 5.2.2     | VSAT Hardware .....  | 49        |
| 5.2.3     | Hub Equipment .....  | 51        |
| 5.3       | Link Budgets for Educational VSAT System.....                          | 53        |
| <b>6.</b> | <b>Performance Analysis of THAICOM-1 Educational VSAT Network.....</b> | <b>62</b> |
| 6.1       | Information Quality.....   | 63        |

6.2 Power-Bandwidth and Earth Station Size Tradeoffs.....64

6.3 Performance Analysis of the Designed-VSAT Network.....66

**7. Conclusions and Recommendations.....74**

**References.....77**

**Appendix A. THAICOM Technical Description.....80**

**Appendix B. Standards.....105**

**Appendix C. Tables of Link Budgets and Figures of Performance**  
**for THAICOM-1 Educational VSAT Network.....108**

**Vita.....127**

# List of Figures

|                   |  |    |
|-------------------|--|----|
| <b>Figure 2.1</b> | Exploded View of A Typical HS-376.....   | 12 |
| <b>Figure 2.2</b> | Cut-away Components HS-376.....  | 12 |
| <b>Figure 2.3</b> | THAICOM-1 Satellite Connectivity.....  | 14 |
| <b>Figure 3.1</b> | Global rain rate climate regions for ocean areas.....  | 18 |
| <b>Figure 3.2</b> | Rainfall regions for Asia and Oceania .....  | 20 |
| <b>Figure 3.3</b> | Schematic presentation of an Earth-space giving the parameters<br>to be input into the attenuation prediction method... .. | 23 |
| <b>Figure 3.4</b> | Nomograph: Specific attenuation due to rain, H, horizontal<br>polarization; V, vertical polarization .....                 | 25 |
| <b>Figure 3.5</b> | Rainfall Intensity Exceed (mm/hr) Vs. Percentage of Year<br>Rain Rate is Exceeded .....                                    | 28 |
| <b>Figure 3.6</b> | 12 GHz Down-Path Rain Attenuation Vs. Percentage of Year<br>Rain Rate is Exceeded .....                                    | 28 |
| <b>Figure 3.7</b> | 14 GHz Up-Path Rain Attenuation Vs. Percentage of Year<br>Rain Rate is Exceeded .....                                      | 29 |

|                    |   |           |
|--------------------|---|-----------|
| <b>Figure 3.8</b>  | System Noise Temperature Increase Due Rain Vs. Percentage of Year Rain Rate is Exceeded.....                                    | <b>31</b> |
| <b>Figure 3.9</b>  | Additional Margin Requirements Vs. Percentage of Year Rain Rate is Exceeded.....  | <b>31</b> |
| <b>Figure 3.10</b> | Attenuation and G/T change Vs. Total Percentage of Year Rain Rate is Exceeded.....  | <b>32</b> |
| <b>Figure 4.1</b>  | The configuration of a VSAT network .....   | <b>37</b> |
| <b>Figure 4.2</b>  | A conceptual diagram of the VSAT network .....  | <b>38</b> |
| <b>Figure 4.3</b>  | ETSIT : An Interactive Multimedia Distance Learning Application.....  | <b>40</b> |
| <b>Figure 5.2</b>  | VSAT Network Star Configuration.....  | <b>48</b> |
| <b>Figure 5.3</b>  | Block Diagram of Proposed VSAT system.....  | <b>50</b> |
| <b>Figure 5.4</b>  | Block Diagram of Proposed Hub System.....   | <b>53</b> |
| <b>Figure 6.1</b>  | BER Vs. Percentage of time, under rain conditions at downlink for Hub-to-VSAT#2 link, using full transponder power.....         | <b>70</b> |
| <b>Figure 6.2</b>  | Link Margin Vs. Percentage of time, under rain conditions at downlink for Hub-to-VSAT#2 link, using full transponder power..... | <b>70</b> |
| <b>Figure 6.3</b>  | BER Vs. Percentage of time, under rain conditions at uplink for VSAT#2-to-Hub link, using full transponder power.....           | <b>71</b> |
| <b>Figure 6.4</b>  | Link Margin Vs. Percentage of time, under rain conditions at uplink for VSAT#2-to-Hub link, using full transponder power.....   | <b>71</b> |

# List of Tables

|                  |   |           |
|------------------|---|-----------|
| <b>Table 3.1</b> | Point Rain Rate Distribution Values (mm/hr) versus Percent of Year Rain Rate is Exceeded.....   | <b>19</b> |
| <b>Table 3.2</b> | Rainfall Intensity Exceeded (mm/hr) for CCIR Rainfall Climatic Regions.....   | <b>19</b> |
| <b>Table 3.3</b> | Attenuation Results at Bangkok and 7 remote sites all over Thailand, satellite: THAICOM-1 (78.5° E).....  | <b>27</b> |
| <b>Table 3.4</b> | Rain Attenuation and G/T Decrease for Earth-Satellite Link in Thailand ....   | <b>33</b> |
| <b>Table 4.1</b> | Specifications of the VSAT Educational Network .....  | <b>39</b> |
| <b>Table 5.1</b> | Specifications of the THAICOM-1 VSAT Educational Network .....  | <b>44</b> |
| <b>Table 5.2</b> | Comparison of BPSK Modulation Schemes.....  | <b>45</b> |
| <b>Table 5.3</b> | System Parameters Used in the Link Design.....  | <b>54</b> |
| <b>Table 5.4</b> | Link Analysis: Bangkok Hub to Ban Mae La Luang (VSAT#1) Link, Hub transmits one coded 4.512 Mbps TDM carrier (outbound) and receive 8 coded 564 kbps SCPC DAMA carriers (inbound). Use Full Transponder Power of THAICOM-1, in Clear Air..... | <b>55</b> |

|                   |   |           |
|-------------------|---|-----------|
| <b>Table 5.5</b>  | THAICOM-1 Worst Case Performance for Ku-band <i>EIRP</i> and <i>G/T</i> .....   | <b>58</b> |
| <b>Table 6.1</b>  | VSAT Network Performance with Changing Transponder Power and VSAT Antenna Size at Ban Mae La Luang in Clear Air.....      | <b>68</b> |
| <b>Table 6.2</b>  | VSAT Network Performance with Changing Transponder Power and VSAT Antenna Size at Ban Mae La Luang in Rain Condition..... | <b>69</b> |
| <b>Table 6.3a</b> | Summary for the THAICOM-1 Educational VSAT Network.....   | <b>72</b> |
| <b>Table 6.3b</b> | Summary for the THAICOM-1 Educational VSAT Network.....   | <b>73</b> |

# Chapter 1 Introduction

In the early days of Thai history, education primarily revolved around two institutions, one religious and the other royal. Buddhist monks gave basic education to boys in schools set up within the compounds of monasteries, while children of the royal household and from families of the nobility were educated in order to serve in the court and govern in the provinces.

During the reign of King Rama V (1868-1910) there was increased recognition of the need for educated people to staff the growing bureaucracy. As a result, the Thai education system was modernized and made more accessible to the general public. This began with the 1898 education proclamation, which was strongly influenced by the British system and in which two educational paths were stipulated, the academic and the vocational. The influence of American and Japanese systems could be discerned in the education proclamation of 1902, which provided for higher education.

The first formal comprehensive education plan was introduced in 1932, the same year the monarchy became constitutional. This plan highlighted four years of elementary education and eight years of secondary schooling. This system was further refined in 1936, when five levels of education were featured; preprimary or kindergarten, primary, secondary, pre-university, and higher education. The educational plan of 1951 was noteworthy in that it facilitated special and adult education.

As part of the emphasis on national development since 1960, a major goal of the educational system has been to harmonize and comply with economic and political plans. The government faced the challenge of widespread illiteracy, as well as the massive task of training young men and women for the dynamic development process in the shortest time possible. Recently it has to modify instruction to include the specialized skills required by industries such as computer science and environmental engineering, together with new branches of medicine. The most recent changes were brought about by the educational plan of 1977, which calls for six years of compulsory primary plus three years of lower secondary schooling, and another three years of upper secondary education for those who plan to enter special occupations or a university. This system was launched in May 1978, beginning with the first grade at both the primary and secondary levels, and continued until the cycle of six grades at both levels was fully implemented in 1983.

Efforts to adapt to the development needs in technology and advanced agricultural methods now suggest a possible future system in which the six-year primary schooling will be extended to nine years, following by three years of secondary education and four years of college or university.

At present there are 16 state universities and 26 privately operated universities and colleges in Thailand[17] and Thailand has population of about 60 million. The ratio of university to Thai people is about 1: 67,000 which is quite low and most of the universities are in Bangkok but the people who need to study are not just in Bangkok. There is a need to find a way to distribute the education from Bangkok to the other areas. One of the advantages of satellite communications is that it has a very wide coverage area. Satellite communications can be used to distribute the education from Bangkok to the other areas, especially rural areas in Thailand, in order to meet the increasing educational demand.

The purpose of this thesis is to apply satellite communications to the needs of education in Thailand by using the national satellite, THAICOM-1. In this thesis, we use the specifications of THAICOM-1 , with the specific propagation conditions found in Thailand to design an educational VSAT system. In this thesis, we show the performance for several scenarios and compare them to find the best way to achieve quality and the greatest economic impact.

Very Small Aperture Terminal (VSAT) satellite communication technology is, by its very nature, ideally suited to rural environments. This form of telecommunications technology has yet to gain a firm foothold or make a significant contribution in the implementation of widespread, efficient, reliable and affordable rural telecommunications networks. It has now become economically viable to propose VSAT networks for rural applications, where the end users are likely to be very low income earners generating low levels of traffic.

The educational VSAT design in this thesis uses digital techniques and Demand Assignment Multiple Access (DAMA) which is one of the latest advances in satellite communications to permit great reductions in the cost of the space segment.

Modern satellite DAMA systems featuring dynamic satellite circuit sharing and switching capabilities, combined with efficient channel encoding to permit improved space segment efficiencies and cost effective replacement of older thin-route ground communications equipment with state-of-the-art technology.

For the remainder of this thesis, chapter 2 presents the background of the THAICOM satellite and education in Thailand and the proposals for a VSAT educational network in Thailand. Chapter 3 discusses propagation in Thailand including calculations of rain attenuation. Chapter 4 describes the tele-education VSAT system. It includes the example of an existing educational VSAT system. Chapter 5 is the design of the educational VSAT network using SCPC DAMA techniques. Chapter 6 examines the performance of the designed system by varying the satellite power and sizes of VSAT to find the best solution for the design, including trade-offs between quality and cost. Chapter 7 finishes with conclusions and recommendations.

The author's contributions to this work correspond to the two main sections of this thesis. First, the VSAT system design work is tailored to the THAICOM-1 satellite. Second, the material in Chapter 6 which uses the propagation data for specific locations in Thailand.

## 2. Background

Thailand is situated between the Equator and the Tropic of Cancer, between 6° and 20° North latitude and between 97.5° and 105.1° East longitude and it serves as a land bond between the Pacific and Indian Ocean. Thailand is a part of the Indochinese Peninsula in South-east Asia. To the north, Thailand is bordered by Burma and Laos, to the east by Laos and Kampuchea, to the south by Malaysia, and to the west with Burma and the Andaman Sea.

Thailand's population is about 60 million. With the total land area of 513,956 km<sup>2</sup> (198,455 mile<sup>2</sup>), Thailand is approximately the size of France and third largest nation in the South-east Asian region, after Indonesia and Burma. The longest part of Thailand from north to south measures around 1,600 km and the widest part around 800 km[17].

## **2.1 A History of Satellite Communications in Thailand**

Currently Thailand is using satellites for many kinds of telecommunications services. Satellite communications in Thailand began after the agreement to be a member of International Cooperative Organization (INTELSAT) in 1996. Thailand used both INTELSAT and Indonesia's Palapa satellites. The main telecommunications organization in Thailand is the Communications Authority of Thailand (CAT) which is responsible to the country's Ministry of Communications and has used INTELSAT for its external services since 1968 and for some internal telephone services since 1982. Another government agency is responsible for broadcasting and had been using Indonesia's Palapa since the late 1970s for television distribution. During that time, there were other government agencies who showed interest in satellites as means of developing specialized telecommunications services for state security, public relations, government information, civil aviation, education, and entertainment purposes.

In recent years Thailand had been looking into how best to satisfy all of these requirements in the years ahead and has also studied the possibility and usefulness of owning its own satellites. There were certain disadvantages to leasing facilities in two different satellite systems as happens at the present time. Because of technical differences, the earth stations could not be used with both satellites. The range of requirements was wide, and to meet them it was necessary to take the most costly approach and for Thailand to purchase its own satellite. In November 1986 there were

reports that Thailand was discussing with the USSR the possibility of launching an RCA satellite. There were obvious political problems with this approach. The United States is generally not in favor of permitting its technical know-how to be available for inspection and use by such countries as the USSR and there are also legal problems. However, it seemed that Thailand had taken at least a preliminary decision to proceed independently towards its own satellite system. This proved correct early in 1987 when the government of Thailand invited tenders for a domestic satellite system. The winner would receive a 30 year concession to lease transponders to government and private sector users, with excess capacity offered to neighboring countries. Shinawatra Computer and Communications Group (SC&C) was awarded the satellite concession in 1991.

On October 8, 1991, Shinawatra Computer and Communications Company, Ltd of Bangkok signed a contract with Hughes Communication International and Advanced Electronic Systems International, both subsidiaries of Hughes Aircraft Company, for the construction of Thailand's first domestic communications satellite system. On December 6, 1991, Shinawatra signed a launch contract with Arianspace for the launch of Thailand's first satellite. On December 17, 1991, His Majesty King Bhumiphol officially named the satellite system "THAICOM", which symbolized the link between Thailand and communications technology.

## **2.2 THAICOM: Thailand's first national communications satellite**

THAICOM is Thailand's first national communications satellite project administered by the Transport and Communications Ministry. The Thai government

approved this project as a “National Project”, which means that the ministry would own the complete system: satellite, earth stations, and all equipment needed to operate the spacecraft. All government agencies and private business are required to use the system.

Shinawatra Computer and Communications (SC&C) Co., Ltd. has been awarded a 30 year concession of Thailand’s first satellite from the Transport and Communications Ministry. Shinawatra Satellite Co., Ltd. (SSA), a subsidiary of SC&C, is responsible for the satellite project as an operator.

The main purpose of THAICOM is to support the increasing need in Thailand and the Region for telecommunications infrastructure due to rapid economic growth. It will also provide a very strong signal for more effective use of satellite communications. THAICOM will also facilitate the development of new satellite applications and technology. Currently there are two satellites operating in Thailand, THAICOM-1 and -2 which are the first generation and were launched in December 1993 and October 1994, respectively. These two satellite are at 78.5°E. They were launched as a pair so that they can back up each other. THAICOM-3 is the second generation , it will be launched in late 1996 at 120°E. In late 1996, THAICOM-1 will be sent to 120°E and become THAICOM-1A and THAICOM-3 will move to 78.5°E. The second generation will be launched for replacement of the first generation satellites as they reach end of life.

THAICOM has three main contractors. The first is Hughes Aircraft (USA) which is responsible for the construction of THAICOM satellites and advises on technical details of use and control from the ground station. The second is Arianespace (France)

which is responsible for launching the THAICOM satellites by the Ariane 4 rocket into proper orbits. And the third is Telespace (Canada) which is responsible for advising on technical matters in the THAICOM project.

### **2.2.1 Launching THAICOM into Orbit**

The first THAICOM satellite was launched into a geosynchronous orbit 35,786 km above the Earth in the equatorial. This satellite is at 78.5° E longitude. A satellite in this orbit has a rotational period of one sidereal day (approximate 24 hours) which matches that of Earth's rotation; therefore, the satellite appears "stationary" and the orbit is called the "geostationary orbit".

The launch site is located in Kourou, French Guiana which is north of Brazil in South America. Since the launch site is closer to the equator than any other launch sites, less fuel will be required to place a satellite into an orbit in the equatorial plane. Ariane 4 accomplishes its mission when it releases the satellite into an elliptical transfer orbit at an altitude of about 200 km, which is the closest distance to the Earth but the farthest distance from various ground stations that will be involved in tracking and maneuvering each satellite from transfer orbit to its designated location in geostationary orbit. Since the period of this transfer orbit is less than 24 hours, a satellite in this orbit will appear as "moving" relative to an observer on the ground. To achieve visibility of a satellite in this orbit at all times, two ground stations, one in the western hemisphere and another one in eastern hemisphere, are generally required.

For THAICOM, a ground station in the USA and a ground station in Indonesia provide visibility for the western and eastern hemispheres respectively. Once the satellite reaches the peak altitude of this transfer orbit that is closest to the desired longitude, the on-board rocket engine called the Apogee Kick Motor (AKM) is ignited to place the satellite into a circular orbit that is almost the geostationary orbit. Only one ground station is in control to adjust the orbit and place the satellite at its designated location using hydrazine thrusters. The control of the satellite is then handed over to the main ground control station to take care of and maintain this satellite for the rest of its operational life.

### **2.2.2 Technical Description of THAICOM**

Each of the first two THAICOM satellites carries ten C-band and two Ku-band transponders. The C-band transponders receive and transmit signals in the 6 GHz and 4 GHz frequency ranges respectively. The 36-MHz-wide C-band transponders, which will be powered by 11 watt solid-state amplifiers (SSPAs), will produce a minimum EIRP of 37 dBW over Thailand and 35 dBW at beam edge. The satellite's C-band footprint will include Thailand. THAICOM can also reach cities such as Rangoon, Vientiane, Phnom Penh, Kuala Lumpur, Hanoi, Ho Chi Min City, and Singapore in Southeast Asia, Beijing, Hong Kong, Seoul, Taipei, and Tokyo in East Asia. The Ku-band transponders receive and transmit signals in the 14 GHz and 12 GHz frequency ranges respectively. The 54-MHz-wide Ku-band transponders, which will be powered by 47-watt traveling wave tube

amplifiers (TWTAs), will produce a minimum EIRP of 51 dBW focused only on Thailand and adjacent countries in Indochina. The technical descriptions of THAICOM - 1, THAICOM -2 and THAICOM -3 appear in Appendix A.

### **2.3.3 Details of HS-376 THAICOM satellite**

The HS-376 satellite is the spacecraft built by the Hughes Aircraft Corporation for domestic satellite communications systems. The structure of this satellite model is a cylinder that achieves stability in space by rotating about its axis in a similar manner to a spinning top. Typical diameter of this satellite is 2.16 meters and its height is 2.56 meters in a stowed configuration. When the antenna and AFT solar panel are fully deployed, the total height is 6.78 meters. The communication antenna is 1.8 meters in diameter. The THAICOM satellite has a total mass of 1078 kg at lift-off, 627 kg at the beginning of its on-orbit operation. The dry mass is 439 kg when all of the on-board fuel is depleted.

Electrical power for the satellite will be provided by two sources. The primary sources consists of a solar cell array mounted on the outside surfaces of the cylinders. This source provides 801 watts at the beginning of its operation and will decrease to about 670 watts at the end of a 15 year period due to environmental degradation. The secondary source that is also used as a back-up source consists of a nickel hydrogen battery pack with a capacity of 51.6 A-hr (ampere-hour). This will be the primary electrical source to support all on-board electronics during solar eclipses.

Four 22.2 newton hydrazine thrusters installed on the satellite will be used to spin up and maintain the spin rate of the satellite at 55 revolutions per minute (rpm) to

provide stability in space. Figure 2.1 and 2.2 depict a cut-away view and an exploded view of a typical HS-376 satellite.

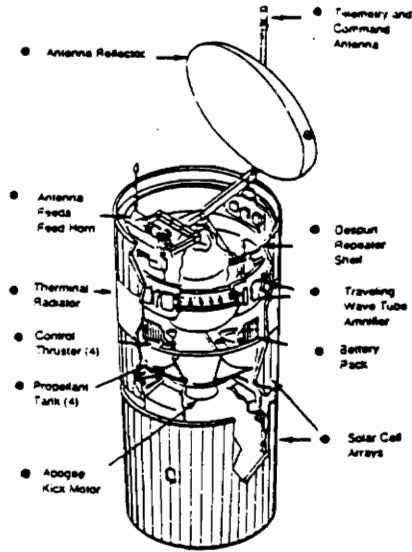

**Figure 2.1** Exploded View of A Typical HS-376 ( From Shinawatra Satellite Public Company Limited [9].)

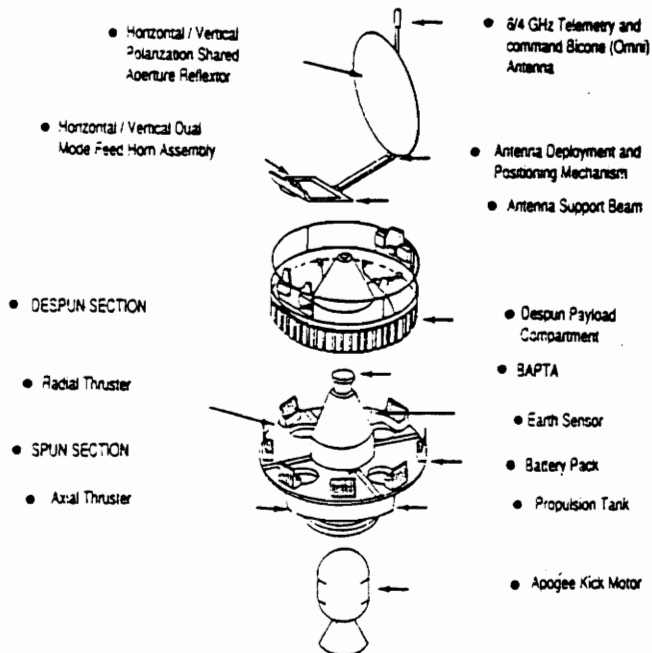

**Figure 2.2** Cut-away Components HS-376 ( From Shinawatra Satellite Public Company Limited [9].)

## 2.3 Proposals for a VSAT Educational Network in Thailand

The communications Technology Satellite, THAICOM, can provide Thais with an opportunity to explore the potential of satellite technology in distance education. This section describes the proposals for a VSAT educational network in Thailand.

The VSAT educational system which will be designed for use with the THAICOM-1 Satellite using compressed digital video and Ku-band very small aperture terminal (VSAT) technology. The central university in Bangkok is linked with seven remote sites via the THAICOM-1 Satellite located at  $78.5^{\circ}$  E longitude. Five remote terminals are located at Ban Mae La Luang, Ban Chai Buri, Ban Khemma Marat, Ban Kholng Makham, and Rangae. These five sites were chosen because of their remoteness. They are at the border of Thailand and very far from Bangkok - about 1,000 km. Therefore, to design the network covering all of Thailand, it is best to choose the longest distance location from Bangkok. Two other terminals are at Chiang Mai and Phuket. Chiang Mai is called the second capital city of Thailand and Phuket is the only province that has island geography. An illustration of the satellite links between Bangkok and seven sites all over Thailand is shown in Fig. 2.3.

Considering the remoteness of the seven sites, and their requirement for very small aperture terminal (VSAT) equipment, this design will demonstrate the advantages of digital compression technology when applied to a television signal. By using video compression, antenna sizes could be minimized at the remote stations.

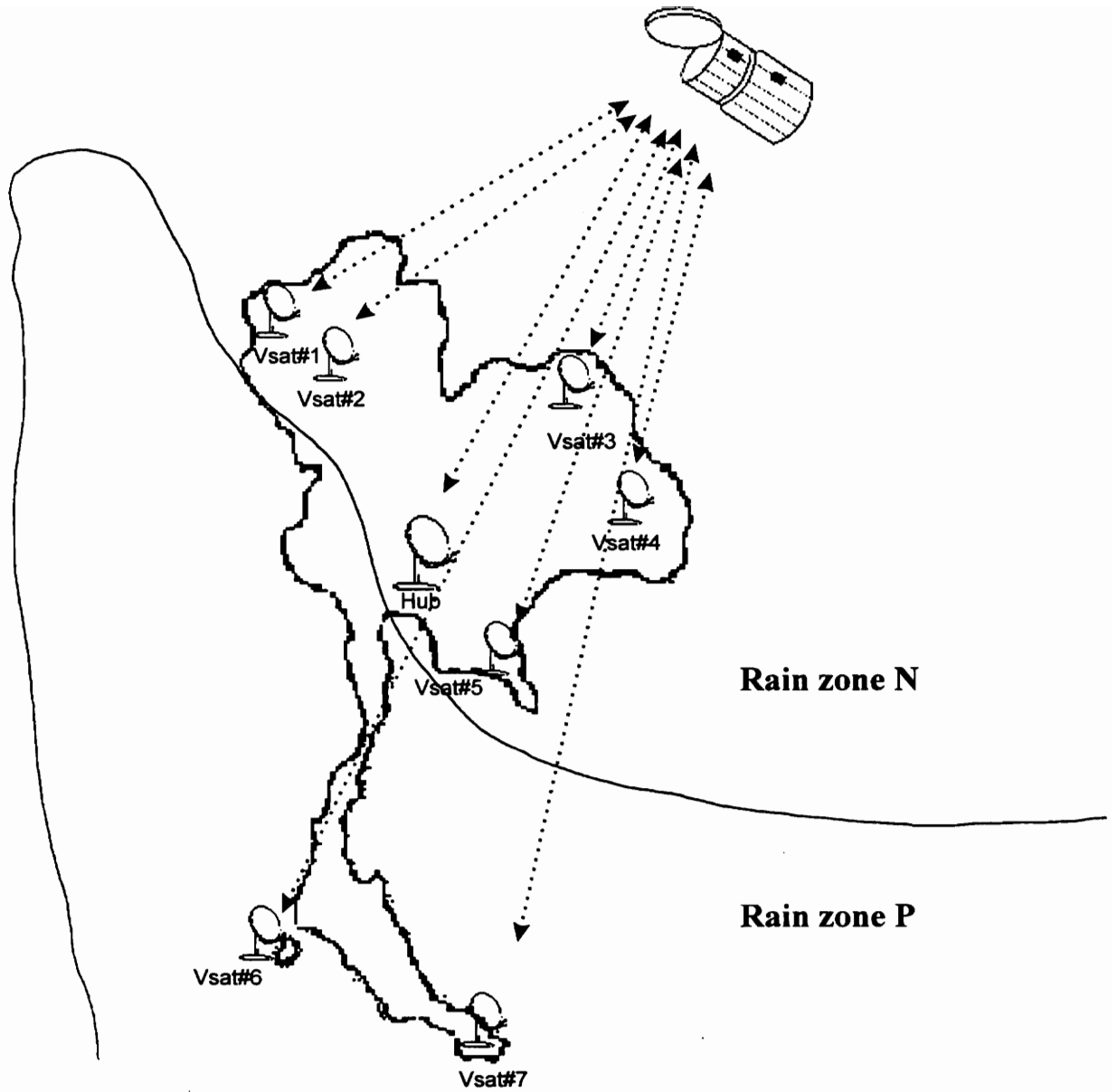

- Hub - Bangkok
- Vsat #1 - Ban Mae La Luang
- Vsat #2 - Chiang Mai
- Vsat #3 - Ban Chai Buri
- Vsat #4 - Ban Khemma Marat
- Vsat #5 - Ban Khlong Makham
- Vsat #6 - Phuket
- Vsat #7 - Rangae

**Figure 2.3 THAICOM-1 Satellite Connectivity**

## **Chapter 3 Propagation In Thailand**

### **3.1 Thailand in Tropical Climate**

Thailand is in the tropical regions which experience significant rainfall. The earliest attempts of the International Radio Consultative Committee (CCIR) to categorize rain on a global basis placed almost all the equatorial region in one of only five climate zones and assumed that the highest rain rates and most frequent occurrences of rain would occur there[28].

In many tropical countries, towns and cities are usually separated by dense forests or similarly inhospitable features. The laying of transmission lines or the construction of terrestrial microwave links are daunting tasks, but communications lifelines are essential for any country, big or small, if it is to grow economically. Traditional technologies are unlikely to provide the rapid breakthrough required and new solutions will be needed. One of these is the introduction of satellite services that are, to a large degree, distance and terrain independent. Unfortunately, they are not climate independent.

The world-wide expanding needs in telecommunications have led to the saturation of the C band (4-8 GHz) and lower bands with microwave communications systems. Consequently, more and more satellite systems are operating at frequencies ranging from 12 GHz to 30 GHz ( Ku, K and Ka bands). Such systems have the advantage of offering more bandwidth and higher antenna gain, thus allowing for more flexibility and improved channel capacity. Also, there is considerable growth of low fade margin systems using low-cost earth-stations such as very small aperture terminals (VSATs). The primary problems in operating at frequencies above 10 GHz are the attenuation and depolarization of the satellite signal caused by rain. The frequency which we chose for the educational VSAT network using a VSAT system in this thesis is Ku-band because our objective is to provide an educational network just in Thailand. Propagation impairments at Ku-band can be significant and, in some cases, the limiting factor in the design of communications services. It is therefore essential to be able to accurately predict the likely impairments to be encountered on a given link in order to plan new services economically. The prediction of propagation impairments is an iterative procedure. Initial theoretical models are tested against measured results. The availability of a substantial database of propagation effects measured on satellite links in temperate regions has, over the last decade, permitted the prediction models for these climatic regions to become quite accurate, particularly in the frequency range between 10 and 20 GHz. The same is not true for tropical regions.

### 3.2 Global & CCIR Model for Tropical Climate

The “Global” rain-rate climate model is based on the similarity of the meteorological processes throughout the world and on the observed total annual rain accumulations. The intent of this model was to identify regions where rain-rate observations would be sufficiently alike to be pooled to provide statistically stable estimates of the annual cumulative distribution function (c.d.f.) of rainfall rate within a region. In this way, a rain-rate climatology could be compiled from a limited set of observations[28]. The global climate zones were designed to have wet and dry regions in four latitude bands: polar, temperate, subtropical (the trade wind regions) and tropical. The boundaries of the latitude bands were decided on the basis of the meteorological processes; wet or dry was decided on the basis of rain accumulation. The global rain climate regions for ocean areas is given in Figure 3.1[12]. Region A spans from about 50° latitude to the poles. Region B and its subdivisions range from as far north as 73° to as low as 40° in mountainous or elevated regions. The north-south asymmetry of the globe is evident in the absence of a region B from the southern hemisphere. Regions C (maritime) and D (continental ) are for temperate latitudes. Region F (dry ) ranges through the temperate and subtropical latitudes to near the equator, region E is subtropical and wet, and regions G and H are the tropical zones, with H being wet. Numerical values of the instantaneous point rain rate distribution for the Global model are provided in Table 3.1.

The subsequent CCIR (International Radio Consultative Committee) rain-rate climate model was initially based on separate analyses for Canada and Europe but with guidance taken from the Global model for the rest of the world. Since its first appearance, the CCIR model has been modified using rain-rate observations provided by a number of administrations. Figure 3.2 shows the CCIR rain climate zones and the cumulative rain rate statistics within these regions is given in Table 3.2.

The CCIR method for predicting rainfall attenuation is based on the concept of effective propagation path length through the rain. The corresponding model therefore needs information on the horizontal and vertical extent of the rain along the path. Earlier assumptions relating the vertical extent of the rain to the height of the zero degree isotherm have subsequently been found inappropriate for tropical regions, as have assumptions on the homogeneity of the rain as it falls to the ground[26].

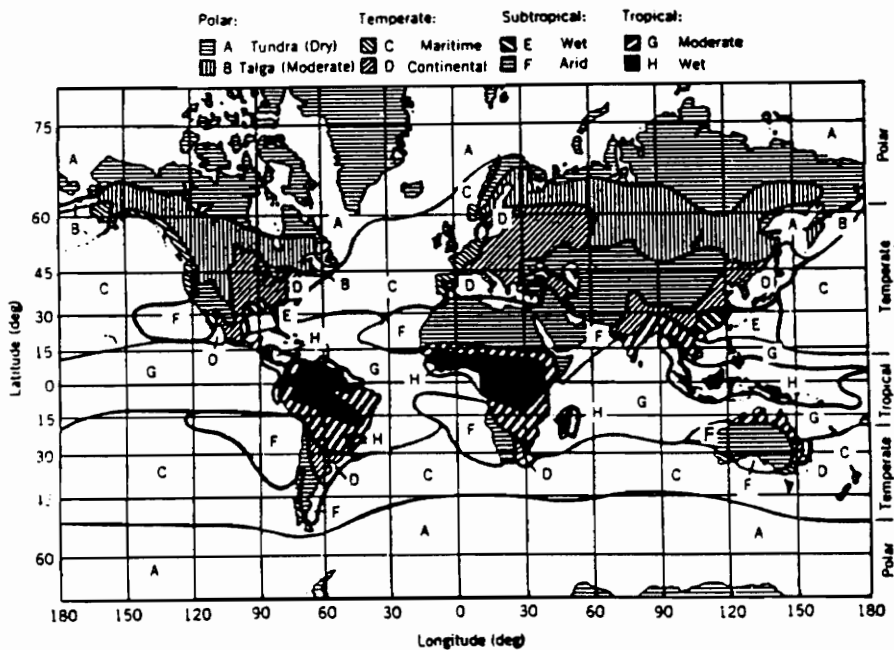

**Figure 3.1** Global rain rate climate regions for ocean areas. (From R. L. Freeman, *Reference Manual for Telecommunications Engineering* [12].)

**Table 3.1** Point Rain Rate Distribution Values (mm/hr) versus Percent of Year Rain Rate is Exceeded. (From R. L. Freeman, *Reference Manual for Telecommunications Engineering* [12].)

| Percentage of Year | Rain Climate Region |     |     |     |     |     |     |     | Outage*          |                |
|--------------------|---------------------|-----|-----|-----|-----|-----|-----|-----|------------------|----------------|
|                    | A                   | B   | C   | D   | E   | F   | G   | H   | Minutes per Year | Hours per Year |
| 0.001              | 28                  | 54  | 80  | 102 | 164 | 66  | 129 | 251 | 5.3              | 0.09           |
| 0.002              | 24                  | 40  | 62  | 86  | 144 | 51  | 109 | 220 | 10.5             | 0.18           |
| 0.005              | 19                  | 26  | 41  | 64  | 117 | 34  | 85  | 178 | 26               | 0.44           |
| 0.01               | 15                  | 19  | 28  | 49  | 98  | 23  | 67  | 147 | 53               | 0.88           |
| 0.02               | 12                  | 14  | 18  | 35  | 77  | 14  | 51  | 115 | 105              | 1.72           |
| 0.05               | 8.0                 | 9.5 | 11  | 22  | 52  | 8.0 | 33  | 77  | 263              | 4.38           |
| 0.1                | 6.5                 | 6.8 | 72  | 15  | 35  | 5.5 | 22  | 51  | 526              | 8.77           |
| 0.2                | 4.0                 | 4.8 | 4.8 | 9.5 | 21  | 3.8 | 14  | 31  | 1,052            | 17.5           |
| 0.5                | 2.5                 | 2.7 | 2.8 | 5.2 | 8.5 | 2.4 | 7.0 | 13  | 2,630            | 43.8           |
| 1.0                | 1.7                 | 1.8 | 1.9 | 3.0 | 4.0 | 1.7 | 3.7 | 6.4 | 5,260            | 87.66          |
| 2.0                | 1.1                 | 1.2 | 1.2 | 1.8 | 2.0 | 1.1 | 1.6 | 2.8 | 10,520           | 175.3          |

\* An outage is said to occur when the operating BER is below a specified threshold continuously for up to ten seconds. If this condition persists for more than ten seconds, the link is considered unavailable [29].

The tropics are defined by the climate zones G and H of the Global climate model or zones N and P of the CCIR climate model that encompass the rainy zones within the equatorial region. CCIR climate zone P overlaps the global climate zones G and H. Global climate region G and CCIR region N are drier tropical zones[28].

**Table 3.2** Rainfall Intensity Exceeded (mm/hr) for CCIR Rainfall Climatic Regions. (From R. L. Freeman, *Reference Manual for Telecommunications Engineering* [12].)

| Percentage of Time (%) | A  | B  | C  | D  | E  | F  | G  | H  | J  | K   | L   | M   | N   | P   |
|------------------------|----|----|----|----|----|----|----|----|----|-----|-----|-----|-----|-----|
| 1                      | -  | 1  | -  | 3  | 1  | 2  | -  | -  | -  | 2   | -   | 4   | 5   | 12  |
| 0.3                    | 1  | 2  | 3  | 5  | 3  | 4  | 7  | 4  | 13 | 6   | 7   | 11  | 15  | 34  |
| 0.1                    | 2  | 3  | 5  | 8  | 6  | 8  | 12 | 10 | 20 | 12  | 15  | 22  | 35  | 65  |
| 0.03                   | 5  | 6  | 9  | 13 | 12 | 15 | 20 | 18 | 28 | 23  | 33  | 40  | 65  | 105 |
| 0.01                   | 8  | 12 | 15 | 19 | 22 | 28 | 30 | 32 | 35 | 42  | 60  | 63  | 95  | 145 |
| 0.003                  | 14 | 21 | 26 | 29 | 41 | 54 | 45 | 55 | 45 | 70  | 105 | 95  | 140 | 200 |
| 0.001                  | 22 | 32 | 42 | 42 | 70 | 78 | 65 | 83 | 55 | 100 | 150 | 120 | 180 | 250 |

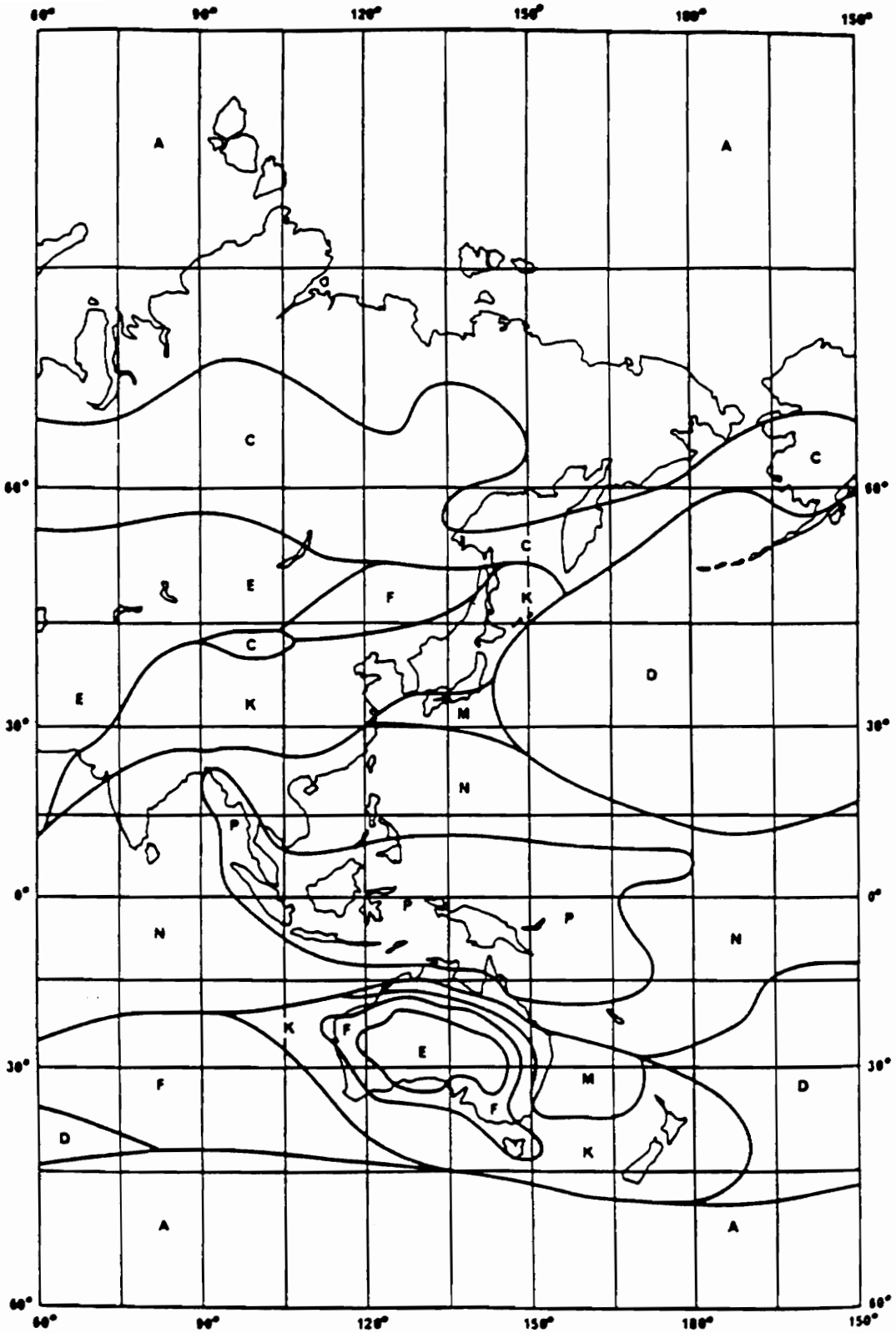

Figure 3.2 Rainfall regions for Asia and Oceania. (From R. L. Freeman, *Reference Manual for Telecommunication Engineering* [12].)

### **3.3 The Climate of Thailand**

Lying between the Equator and the Tropic of Cancer (Latitude  $6^{\circ}$  N -  $20^{\circ}$  N, Longitude  $97.5^{\circ}$  E -  $105.1^{\circ}$  E), Thailand is enriched with a tropical climate receiving two seasonal monsoons : south-western and north-eastern winds, which cause abundant rain throughout the country especially along the eastern coast lines of the South. The annual average rainfall is approximately 1,500 millimeters[18]. The distribution of climate in Thailand ranges from tropical moderate, roughly corresponding to CCIR rainfall climatic zone N, to an equatorial climate possessing one of the highest rainfalls in the world, or zone P of CCIR. For the Global climate model, it is defined by the climate zones G and H.

In tropical Thailand, the rain is in general convective with high rain rates and large drops, and often associated with thunderstorms. However, in the mountains and hilly regions the precipitation type is orographic; i.e. it results from the forced uplift of air over the high ground, creating rainfall on the windward side of the mountains mostly. Regions of low altitude surrounding the mountains do not get as much rainfall as inland areas. As a result of the combination of climatic zones with highlands and coastal regions, the precipitation pattern can change drastically within a small geographical area.

### **3.4 Rain Attenuation in Thailand**

Rainfall is a major cause of signal degradation for terrestrial and Earth-space communication systems operating at centimeter and millimeter waves. Attenuation due to rainfall plays a significant role in the design of terrestrial and Earth-satellite radio links especially at frequencies above 10 GHz. This is especially true in tropical regions, which are characterized by high intensity rainfall, enhanced frequency of rain occurrence and the increased presence of large raindrops when compared with temperate climates[27].

For calculating the rain attenuation, the overall structure of the rain must be understood, and it is often referred to by the terms convective or stratiform. In general, tropical rain is considered to be convective, although there is evidence for more stratiform type rain to occur nearer coastal regions. A further complication involves the vertical structure, particularly with convective type rain. The time for raindrops to fall to the ground is approximately in the range 5 to 15 min., which is significant in comparison with the lifetime of rain showers. Thus, in climates with heavy rainfall like Thailand, the concept of a simple rain cell may overestimate the propagation path length through the rain and thereby overestimate the resulting attenuation.

### **3.4.1 Attenuation Calculation**

The method for calculation of rain attenuation consists of determining the effective path length through the rain and multiplying by the specific attenuation of the rain appropriate for the region under consideration. Figure 3.3 gives a schematic presentation of the Earth-space path, indicating the parameters required for the

determination of the effective path length,  $L_e$ . This requires a knowledge of the rain height, which in Fig. 3.3 corresponds to the position of the broken line B, and is referred to as  $h_R$ .

The rain attenuation calculations which we use here use the latest CCIR propagation models[25]. Compared to previous versions, these latest attenuation models predict a more benign rain fade environment at Ku band in tropical climates. The CCIR model is based on predicting the attenuation expected for 0.01 percent of the time and then scaling it to other percentages.

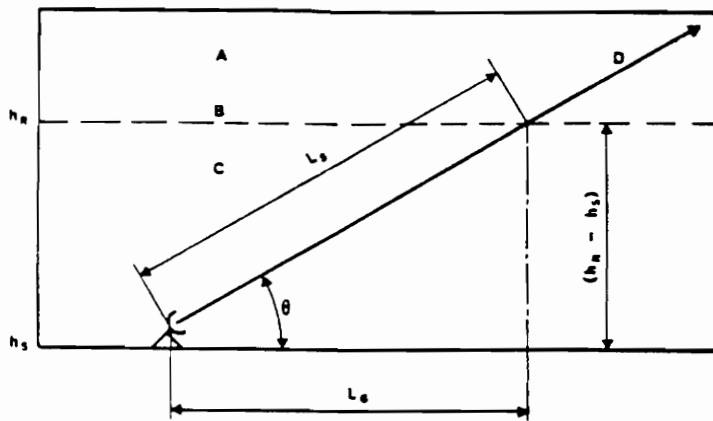

**Figure 3.3** Schematic presentation of an Earth-space giving the parameters to be input into the attenuation prediction method.

A = frozen precipitation; B = rain height; C = liquid precipitation;

D = Earth-space path.

( From K. A. Hughes, "CCIR Data for Slant-path Propagation in Tropical Regions," [26] )

For earth station latitude  $\Lambda_e$ , the rain height  $h_R$  (km) is calculated by

$$\begin{aligned}
 h_R &= 3 + 0.028\Lambda_e, 0 \leq \Lambda_e < 36^\circ \\
 &= 4 - 0.075(\Lambda_e - 36), \Lambda_e \geq 36^\circ
 \end{aligned}
 \tag{1}$$

The slant-path length  $L_S$  is calculated from  $h_R$ , the station height above sea level  $h_O$  (km), and the path elevation angle  $EL$  by

$$L_S = \frac{h_R - h_O}{\sin EL} \quad (\text{km}) \quad (2)$$

The path length reduction factor of the rain rate,  $r$ , for 0.01% of the time is calculated from the horizontal projection of the slant path  $L_G$  by

$$r_{0.01} = \frac{1}{1 + \frac{L_G}{L_O}} \quad (3)$$

where  $L_G = L_S \cos EL$  (km) (4)

and  $L_O = 35 \exp(-0.015R_{0.01})$  (km) (5)

and  $R_{0.01}$  is the rainfall rate corresponding to 0.01 percent outage. Then the attenuation for a given percentage outage as predicted by the CCIR model is

$$A_{0.01} = L_S \Gamma r_{0.01} \quad (\text{dB}) \quad (6)$$

where  $\Gamma$  is the specific attenuation (dB/km). Determine  $\Gamma$  by using the nomograph of Figure 3.4 as a function of  $R_{0.01}$  and frequency.

The attenuation  $A_X$  predicted for any other percentage may be calculated from  $A_{0.01}$  by

$$\frac{A_X}{A_{0.01}} = 0.12 p^{-(0.546 + 0.043 \log p)} \quad (7)$$

where  $p$  is the percent outage of the time.

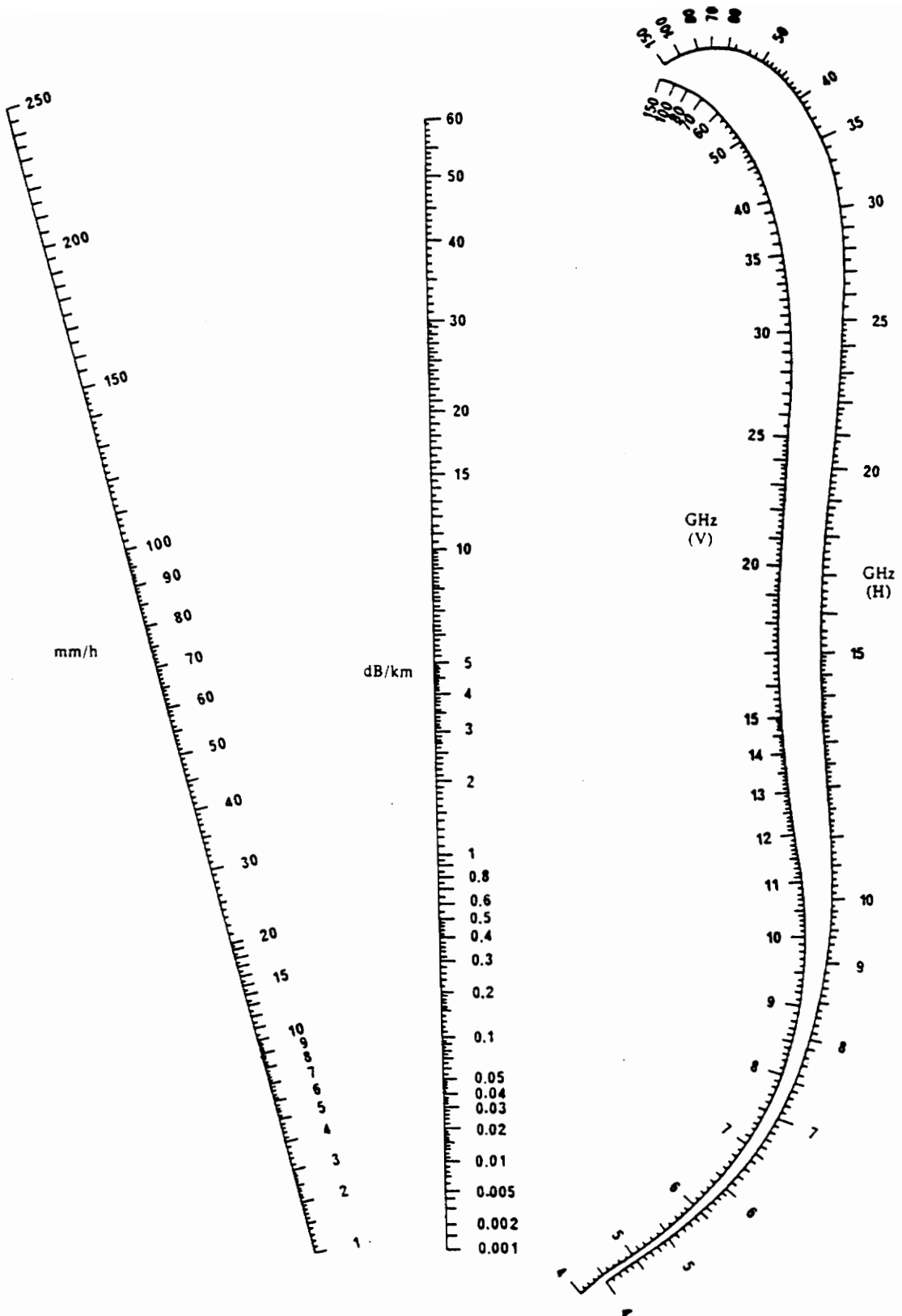

**Figure 3.4** Nomograph: Specific attenuation due to rain, H, horizontal polarization; V, vertical polarization. (From R. L. Freeman, *Reference Manual for Telecommunication Engineering* [12].)

### 3.4.2 Attenuation Results

By using the attenuation calculation in 3.4.1, the calculated rain attenuation at 7 sites all over Thailand are presented in Table 3.3.

From Fig. 3.2, Table 3.2 and 3.3, we observe a significant spread in rain rate distribution over Thailand. Thailand is located within zone N and P. Therefore, it is logical to offer two system designs for Thailand, the first design is for the northern, north-eastern and middle part of Thailand (zone N) and the second design is for the north-western and southern part of Thailand (zone P). For example, a larger antenna will perhaps be more appropriate for the southern part coverage, provided that an appropriate margin is assigned for the system noise degradation due to rain. Rainfall Intensity Exceeded versus outage time percentage of year are plotted in Fig. 3.5 for zone N and zone P.

Rain attenuation margin has been calculated as a function of rainfall rate of zone N and zone P for frequency bands 12 and 14 GHz, which are shown in Fig. 3.6 and 3.7, respectively.

**Table 3.3** Attenuation Results at Bangkok and 7 remote sites all over Thailand, satellite: THAICOM-1(78.5° E)

| Location                  | Hub      | Vsat#1  | Vsat#2  | Vsat#3   | Vsat#4   | Vsat#5   | Vsat#6  | Vsat#7   |
|---------------------------|----------|---------|---------|----------|----------|----------|---------|----------|
| Coordinates :             | 13.44 N  | 18.28 N | 18.48 N | 17.38 N  | 16.04 N  | 11.42 N  | 7.52 N  | 6.15 N   |
| (deg)                     | 100.30 E | 97.55 E | 98.59 E | 104.28 E | 105.10 E | 102.54 E | 98.22 E | 101.45 E |
| Elevation angle (deg)     | 60.27    | 59.44   | 58.44   | 54.18    | 54.18    | 59.09    | 65.34   | 62.26    |
| Zone                      | N        | N       | N       | N        | N        | N        | P       | P        |
| Dn-link Attenuation(dB) : | 1.0      | 1.02    | 1.03    | 1.03     | 1.03     | 0.99     | 1.20    | 1.19     |
| (12 GHz) of % of Year     | 0.3      | 1.92    | 1.93    | 1.94     | 1.93     | 1.87     | 2.25    | 2.23     |
|                           | 0.1      | 3.26    | 3.26    | 3.28     | 3.26     | 3.16     | 3.81    | 3.78     |
|                           | 0.03     | 5.51    | 5.53    | 5.56     | 5.53     | 5.36     | 6.46    | 6.41     |
|                           | 0.01     | 8.24    | 8.26    | 8.30     | 8.26     | 8.03     | 12.11   | 12.05    |
|                           | 0.003    | 12.71   | 13.02   | 13.09    | 13.02    | 12.62    | 15.20   | 15.09    |
|                           | 0.001    | 17.83   | 18.27   | 18.37    | 18.28    | 17.71    | 21.34   | 21.17    |
| Up-link Attenuation(dB) : | 1.0      | 1.38    | 1.39    | 1.39     | 1.39     | 1.35     | 1.62    | 1.61     |
| (14 GHz) of % of Year     | 0.3      | 2.60    | 2.60    | 2.61     | 2.60     | 2.54     | 3.04    | 3.02     |
|                           | 0.1      | 4.33    | 4.40    | 4.43     | 4.41     | 4.31     | 5.15    | 5.12     |
|                           | 0.03     | 7.34    | 7.46    | 7.50     | 7.47     | 7.30     | 8.72    | 8.67     |
|                           | 0.01     | 11.34   | 11.52   | 11.59    | 11.54    | 11.28    | 13.48   | 13.40    |
|                           | 0.003    | 17.28   | 17.56   | 17.66    | 17.59    | 17.19    | 20.54   | 20.42    |
|                           | 0.001    | 24.25   | 24.64   | 24.79    | 24.69    | 24.13    | 28.82   | 28.66    |

**Note :** From Eq.(6)  $\Gamma$  (12 GHz, Horizontal) zone N = 4, zone P = 6.5

$\Gamma$  (14 GHz, Vertical) zone N = 7, zone P = 10.

Hub : Bangkok,

Vsat #1 : Ban Mae La Luan, Vsat #2 : Chiang Mai

Vsat #3 : Ban Chai Buri, Vsat #4 : Ban Khemma Marat

Vsat #5 : Ban Khlong Makham, Vsat #6 : Phuket

Vsat #7 : Rangae.

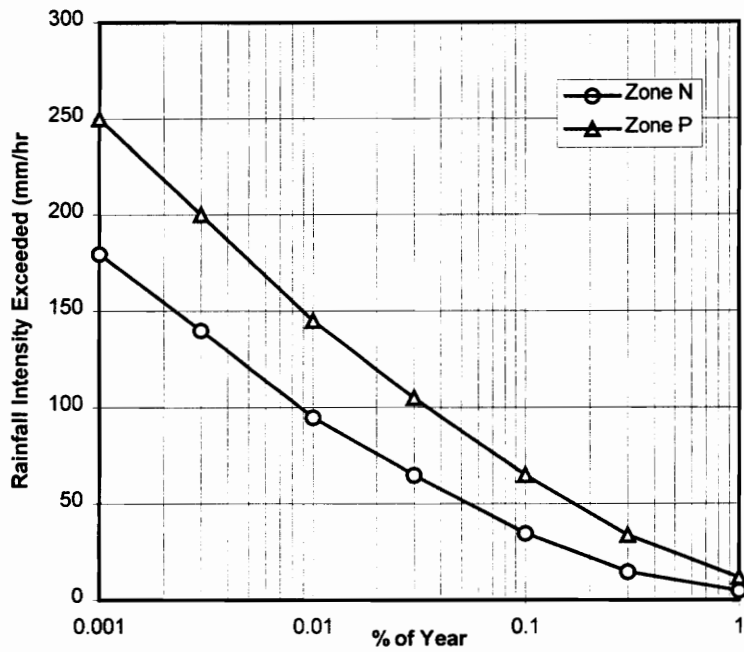

**Figure 3.5** Rainfall Intensity Exceed (mm/hr) Vs. Percentage of Year Rain Rate is Exceeded

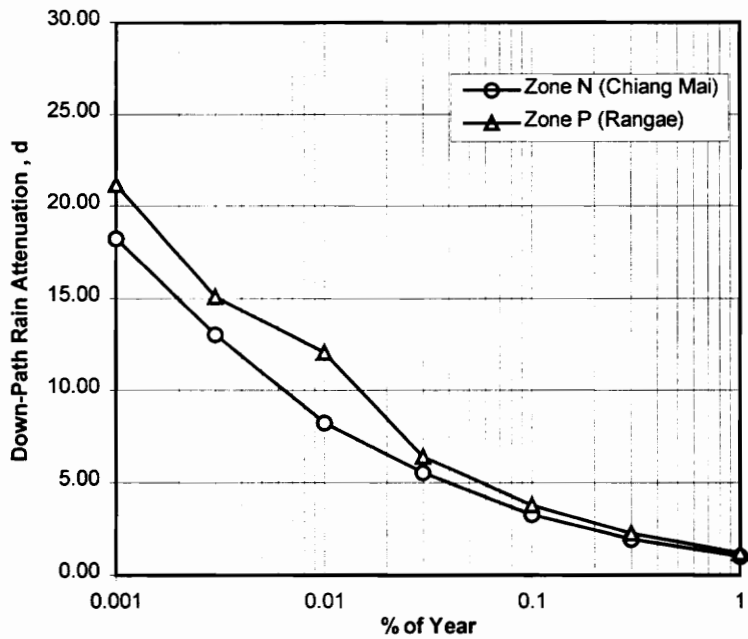

**Figure 3.6** 12 GHz Down-Path Rain Attenuation Vs. Percentage of Year Rain Rate is Exceeded

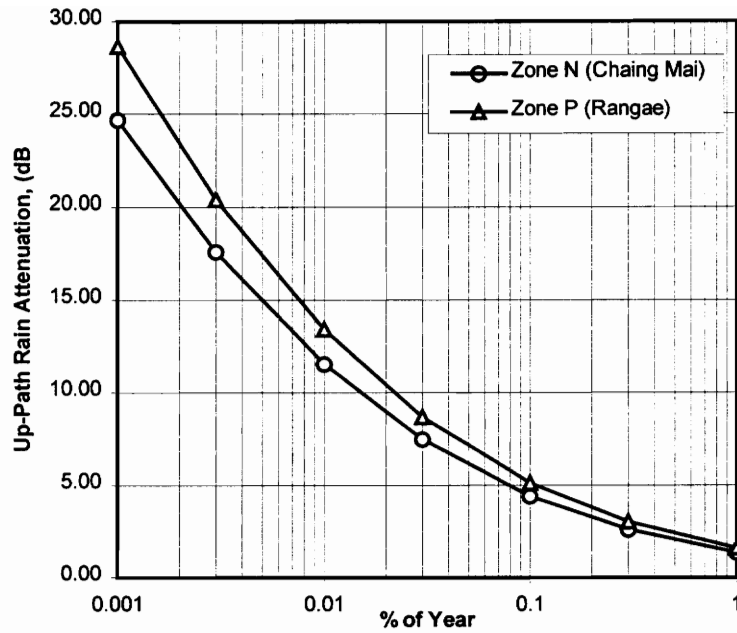

**Figure 3.7** 14 GHz Up-Path Rain Attenuation Vs. Percentage of Year Rain Rate is Exceeded

In addition to the space link attenuation caused by rain, absorption of electromagnetic waves by rain in Ku-band gives rise to increased system noise temperature which must be accounted for in down-path margin, as discussed below.

The receive noise temperature,  $T_r(a)$ , can be written as[3]:

$$T_r(a) = \frac{1}{abc} [T_s + T_a(a - 1)] + \frac{T_o}{b} [(c - 1) + (b - 1)] + T_L \quad (8)$$

where

$a$  = down-link rain attenuation (dependent on climatic region and space link availability; see Fig.3.6)

= 1 under clear sky

$b$  = waveguide loss (1.07 or 0.3 dB typical at Ku-band)  
 $c$  = clear sky attenuation (1.05 or 0.2 dB )  
 $T_s$  = clear sky noise temperature ( $\cong 50$  K ,15 K from antenna +  
 35 K from 0.2 dB atmosphere attenuation)  
 $T_a$  = rain temperature (usually assumed as 270 K)  
 $T_o$  = environmental temperature (308 K assumed in Thailand)  
 $T_L$  = Ku-band commercial cost-effective LNA noise temp.  
 ( $\cong 80$  K, 1996)

Therefore, from (8), we observe that the system noise temperature under rain fade conditions is dependent on the rain rate climatic region and the expected satellite link availability. From Fig. 3.6 and (8), we derive the system noise temperature,  $T_r(a)$ , under rain fade condition, as shown in Fig.3.8. Without rain attenuation,  $a=1$  in (8), and, hence, dry weather system noise temperature,  $T_r$  , becomes

$$\begin{aligned}
 T_r &= \frac{T_s}{bc} + \frac{T_o}{b} [(c-1) + (b-1)] + T_L & (9) \\
 &= 159 \text{ K}
 \end{aligned}$$

Therefore, a margin to combat this system noise degradation due to rain must be provided to achieve a given BER under rain fade. This margin is simply

$$10 \log \left( \frac{T_r(a)}{T_r} \right),$$

which is also plotted in Fig.3.9 as a function of outage percentage of year for zone N and zone P.

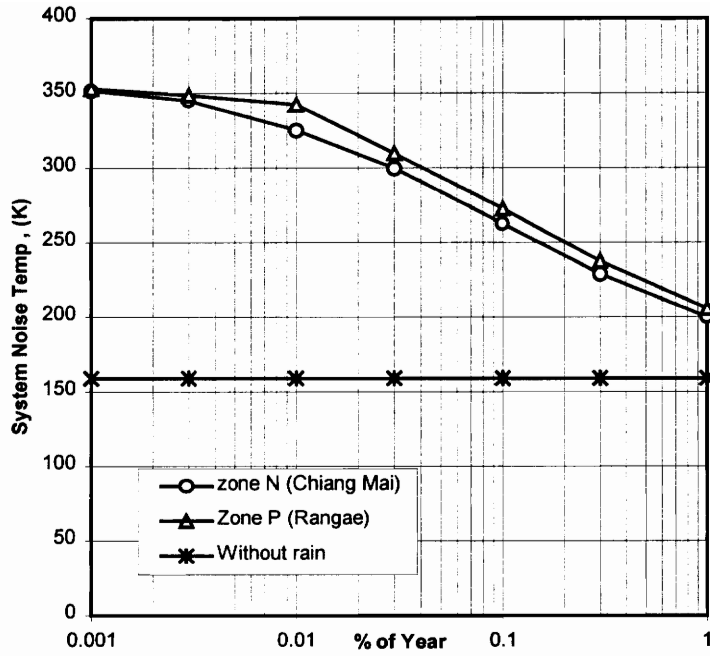

**Figure 3.8** System Noise Temperature Increase Due Rain Vs. Percentage of Year Rain Rate is Exceeded

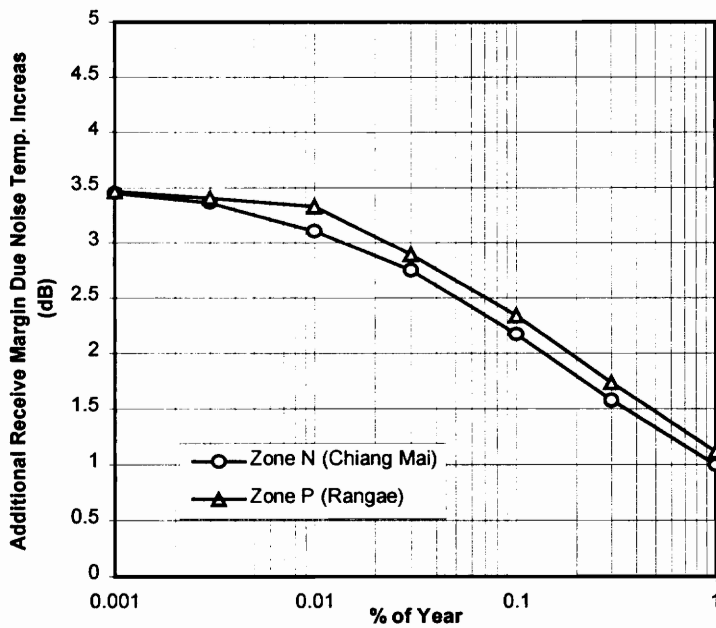

**Figure 3.9** Additional Margin Requirements Vs. Percentage of Year Rain Rate is Exceeded

Assuming a cost-effective nonredundant earth terminal projected availability of 99.9 % ( $A_e$ ), we calculate the space link margins (up-path and down-path, for zone N and zone P) via section 3.4.1 and Fig. 3.6 and 3.7. The results are tabulated in Table 3.4, where the (G/T) degradation margin (see Fig.3.9) is also included in total effect of down-path. Table 3.4 is reproduced in Fig. 3.10.

From Table 3.4, it is observed that attaining an outage margin about 0.1% of the year is clearly uneconomic. Typically, margin in a VSAT system in Thailand will have to be 5-10 dB, with availability at 99.8 to 99.85%.

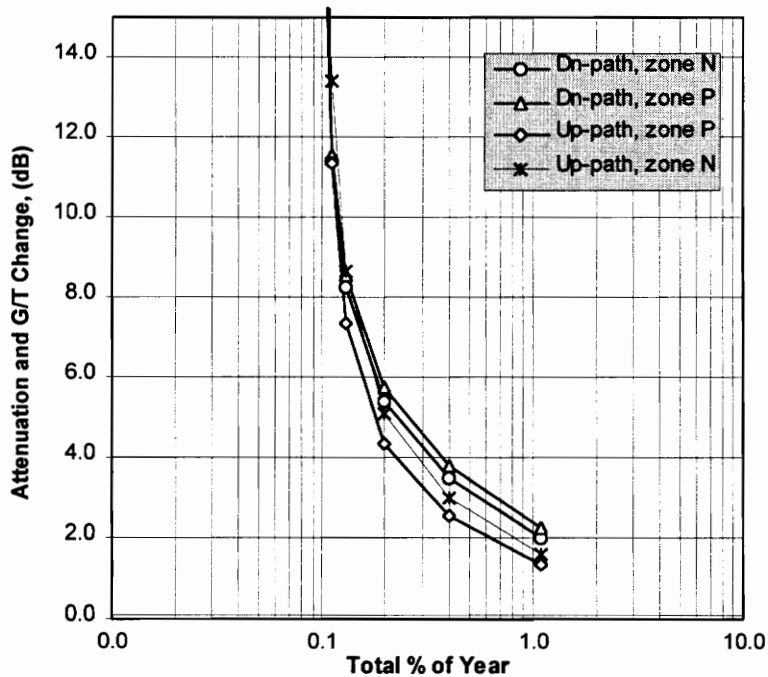

**Figure 3.10** Attenuation and G/T change Vs. Total Percentage of Year Rain Rate is Exceeded

**Table 3.4** Rain Attenuation and  $G/T$  Decrease for Earth-Satellite Links in Thailand (refer to Table 3.3)

| Earth Station Availability | Space link Availability | Total System Availability | Total outage % of year | Outage hrs/year | Attenuation and $G/T$ change, (dB) |                      |              | Zone  |   |   |
|----------------------------|-------------------------|---------------------------|------------------------|-----------------|------------------------------------|----------------------|--------------|-------|---|---|
|                            |                         |                           |                        |                 | Dn-path Atten.                     | Dn-path $\nabla G/T$ | Total Effect |       |   |   |
| 0.999                      | 0.99                    | 0.9890                    | 1.1                    | 96.4            | 1.03                               | 0.97                 | 2.0          | 1.36  | N |   |
|                            | 0.997                   | 0.9960                    | 0.4                    | 35.0            | 1.93                               | 1.56                 | 3.5          | 2.56  |   |   |
|                            | 0.999                   | 0.9980                    | 0.2                    | 17.5            | 3.26                               | 2.15                 | 5.41         | 4.33  |   |   |
|                            | 0.9997                  | 0.9987                    | 0.13                   | 11.4            | 5.53                               | 2.73                 | 8.26         | 7.34  |   |   |
|                            | 0.9999                  | 0.9989                    | 0.11                   | 9.6             | 8.26                               | 3.12                 | 11.38        | 11.34 |   |   |
|                            | 0.99997                 | 0.9990                    | 0.103                  | 9.0             | 13.02                              | 3.35                 | 16.38        | 17.28 |   |   |
|                            | 0.99999                 | 0.9990                    | 0.101                  | 8.8             | 18.27                              | 3.45                 | 21.72        | 24.25 |   |   |
| 0.999                      | 0.99                    | 0.9890                    | 1.1                    | 96.4            | 1.19                               | 1.24                 | 2.3          | 1.61  |   | P |
|                            | 0.997                   | 0.9960                    | 0.4                    | 35.0            | 2.23                               | 1.89                 | 3.82         | 3.02  |   |   |
|                            | 0.999                   | 0.9980                    | 0.2                    | 17.5            | 3.78                               | 2.50                 | 5.76         | 5.12  |   |   |
|                            | 0.9997                  | 0.9987                    | 0.13                   | 11.4            | 6.41                               | 3.02                 | 8.55         | 8.67  |   |   |
|                            | 0.9999                  | 0.9989                    | 0.11                   | 9.6             | 12.05                              | 3.31                 | 11.57        | 13.40 |   |   |
|                            | 0.99997                 | 0.9990                    | 0.103                  | 9.0             | 15.09                              | 3.44                 | 16.46        | 20.42 |   |   |
|                            | 0.99999                 | 0.9990                    | 0.101                  | 8.8             | 21.17                              | 3.48                 | 21.75        | 28.66 |   |   |

Note:  $A_s = A_l \times A_e$  where  $A_s$  : The overall availability  
 $A_l$  : Space-link availability  
 $A_e$  : Earth station availability

# **Chapter 4 Educational Networks Using VSAT Systems**

## **4.1 Introduction**

There was a time when a technical innovation could be viewed as a separate entity, its role in life identified, subsequently developed, and finally brought into operation as some visible and discrete part of the engineering advances of the world. With the increasing complexity of modern technology, the chance of a technical innovation existing in its own right in this way is fast disappearing and indeed it is a matter of education itself, that to be successful, it is essential that any single part of a new concept should be viewed within the whole system at the earliest possible time. There could be few projects now contemplated where this is more true than that of an educational network system via satellite communications where real success will only come from the very best possible system planning [10].

Satellite broadcasting, and satellite communication in general, is one of the very few technological innovations which do not discriminate against people living far from urban centers. In fact the signal quality would generally be better in rural areas than in

large cities [11]. There are many ways to construct an educational network system but one of the best ways is by using a very small aperture terminal (VSAT) system.

VSAT systems are used primarily for data communications via satellite but may also be used for voice and image communications. There is no single, standardized definition of a VSAT. However, there are a number of parameters and characteristics that are generally understood as being associated with VSAT networks:

- The earth station antenna is invariably small, usually 1.0 to 2.4 meters in diameter.
- The capital cost for each VSAT is low. In VSAT networks, the capital cost of the earth-stations dominates the economics of the system.
- VSATs are normally both transmit and receive earth stations.
- The VSAT network architecture is usually a pure star in which a large earth station or the hub is linked to many VSATs. All the transmission links are between a VSAT and hub. Communication between VSATs is only possible by using a double-hop arrangement from one VSAT to the hub and then to another VSAT.
- Each VSAT in a network has a unique address allowing blocks of data to be transmitted to a specific VSAT or group of VSATs in a fashion similar to that used in terrestrial packet-switched networks.
- All VSATs have a data transmission capability and some versions can also carry one-way TV or two-way audio channels.

- All VSATs use a standard commercial communications satellite.

This chapter introduces some existing educational satellite TV systems; we first describes the Japanese VSAT educational network. Next, the Tele-Education multimedia system in Spain is introduced . Finally, we explain the satellite TV system of Virginia Tech.

## **4.2 Mitsubishi VSAT Educational Network**

In Japan, satellite communications systems using VSATs are expected to soon find applications in corporate communications networks for transmitting video and audio signals, and other types of data[7]. Mitsubishi company introduced a production-ready VSAT-based educational network to be one of these applications. The VSAT network in Fig. 4.1 shows some of the possibilities using equipment available from Mitsubishi Electric.

### **4.2.1 Features**

A VSAT-based educational network can be used to support corporate in-house education programs and commercial schools of various kinds. A VSAT system is effective for an educational network. A basic VSAT educational network consists of one earth station, serving as the communications hub, and multiple VSAT installations at remote classrooms. The communications between hub and VSATs can be implemented in any number of ways.

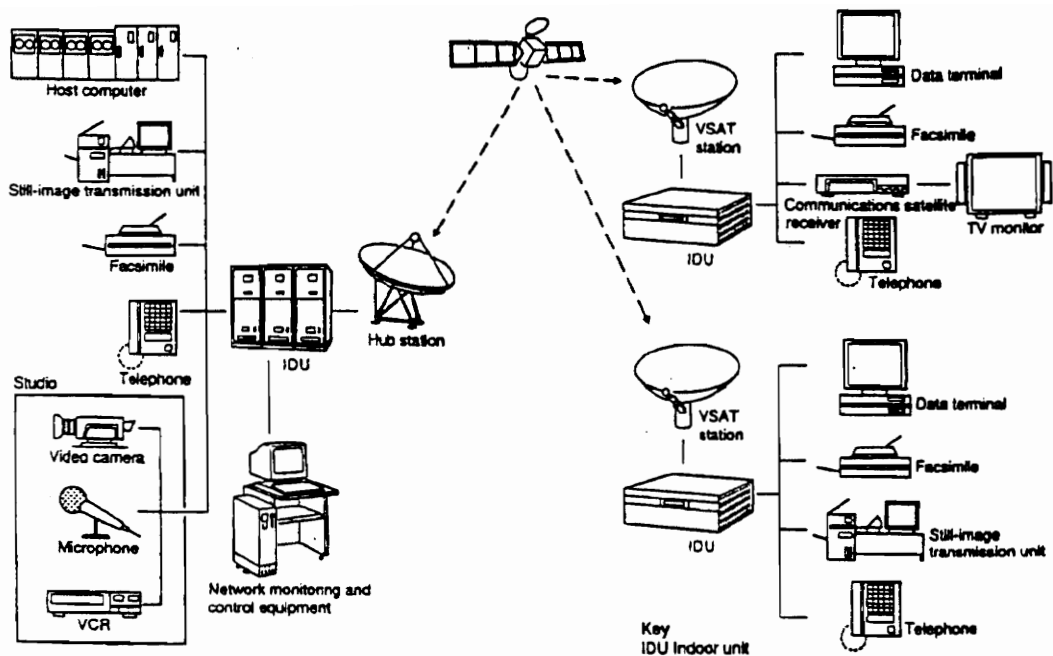

**Figure 4.1** The configuration of a VSAT network ( From Y. Nomachi, *Mitsubishi Electric Advance* [7].)

Bi-directional communications are possible using bi-directional satellite links, or by using a one-way (broadcast style) satellite links for communications from the hub to the VSATs and the public telephone network for communications from the VSATs to the hub.

The Mitsubishi VSAT educational network described here employs bi-directional satellite links and supports the following functions:

1. Full-motion video broadcasts (outbound)
2. Still-image transmissions (inbound)
3. Bi-directional audio channels
4. Digital data transmission and reception

## 4.2.2 Network Configuration

The network consists of a studio at the hub station and VSAT stations that can be placed anywhere in Japan. The basic operation scenario assumes a television conference followed by a real-time discussion among the lecturer and instructors at the studio and students at the remote classrooms.

A single video signal is transmitted using an outbound carrier which is modulated using analog FM, and inbound communications use one time division multiple access (TDMA) carrier with ten single channels per carrier (SCPC).

The diagram of Figure 4.2 shows how the network operates, and Table 4.1 lists its capabilities.

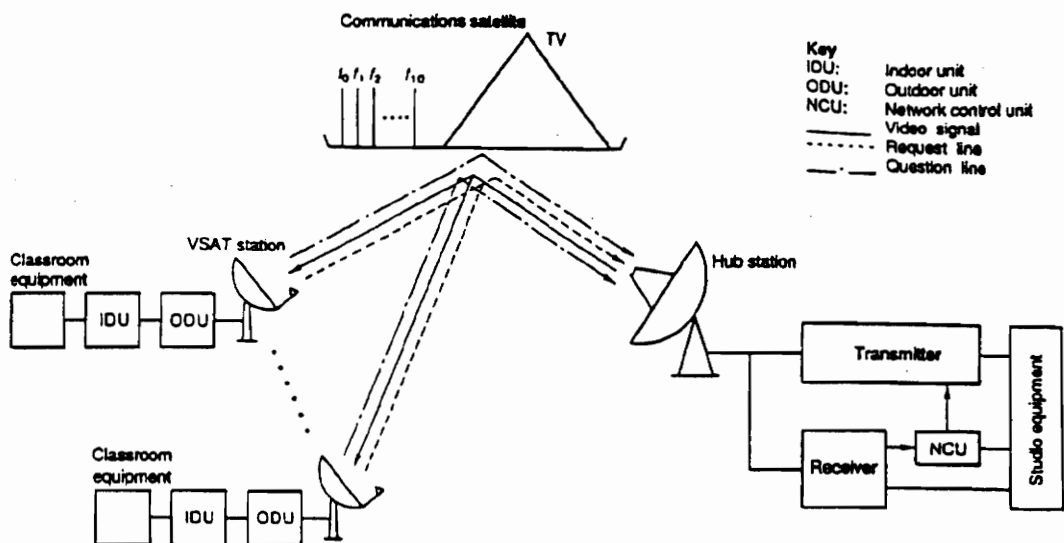

**Figure 4.2** A conceptual diagram of the VSAT network ( From Y. Nomachi, *Mitsubishi Electric Advance*[7].)

**Table 4.1** Specifications of the VSAT Educational Network (From Y. Nomachi, *Mitsubishi Electric Advance* [7].)

| Parameters             | Performance   |
|------------------------|---|
| No. of remote stations | 100 max.  |
| Satellite circuit      |   |
| Outbound transmissions |   |
| No. of carriers        | 1   |
| Access system          | Frequency division multiplexing   |
| Video modulation       | FM  |
| Audio modulation       | 4-phase shift keying  |
| Control signals        | 4-phase shift keying  |
| Inbound transmissions  |   |
| No. of carriers        | 11  |
| Access system          | Demand assigned multiple access<br>(10 carriers)<br>Fixed-assignment TDMA slots<br>(1 carrier)      |
| Modulation             | 4-phase shift keying  |
| Data transmission rate | 128 kbps in burst-mode<br>transmissions<br>64, 128 or 256 kbps in continuous<br>modem transmissions |

### 4.3 An Existing Educational VSAT System in Spain

This is another example of a VSAT educational network. The ETSIT project is the name for the Tele-Education multimedia system in Spain, able to manage data, voice and video for distance-learning via the Hispasat Satellite.

The ETSIT project serves 8 telecommunication universities within Spain, included Canary Islands. More than 30 distance-learning courses have been transmitted

to 1500 students with more than 350 class hours. Surveys suggested that between 73 and 100% of the attendant students consider the experience very positive, besides the education received, and 60% of the student population apply again for new seminars[6].

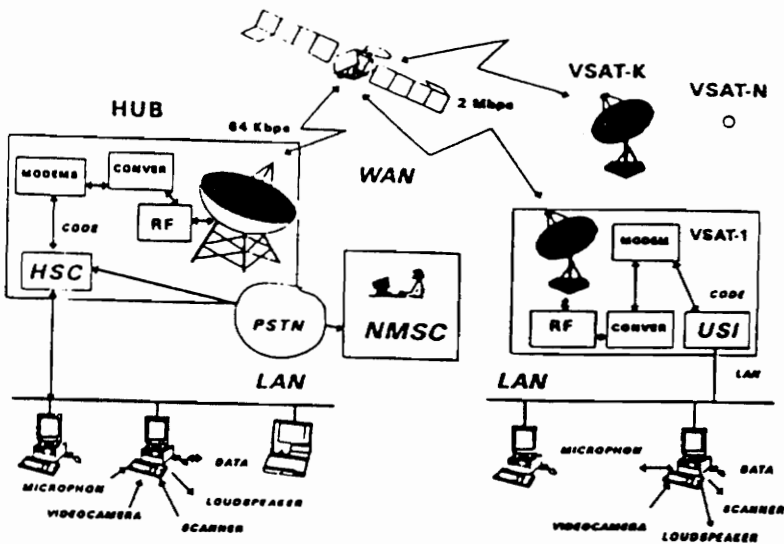

**Figure 4.3** ETSIT : An Interactive Multimedia Distance Learning Application (From J.Gerardo Muros, *Tenth International Conference on Digital Satellite Communications* [6].)  
 Note: HSC: Hub Station Controller, USI: User Standard Interface

A block diagram of the ETSIT project is shown in Figure 4.3. The real time lectures from the teacher classroom at Hub facility are sent to eight remote students classrooms connected to the VSAT network. The live lecture is broadcast to remote VSATs, and the students receive high quality video of the teacher, his or her voice, and any kind of educational supporting material.

The remote student interacts to the real time lecture by returning low rate video, and open audio to the teacher, by means of a video camera and microphones distributed within each remote student classroom.

One outbound signal is broadcast from the Hub to all VSATs in a TDM frame format. Up to ten inbound carriers can be sent from the VSAT to the Hub using an FDMA scheme. The carrier data rate is variable from 9.6 kbps to 2 Mbps.

A population of 100 users can be served with one outbound channel and three inbound channels and can be enhanced to 300 users by adding three more inbound channels at 64 kbps.

#### **4.4 Satellite TV System of Virginia Tech**

Virginia Tech's distance learning project extends live, interactive instruction from the campus to cooperating institutions by using one full transponder per video channel for C-band transmissions. Courses are broadcast using specially designed electronic classroom studios. Faculty have an overhead camera for displaying instructor prepared materials. The full transponder bandwidth is used for each outbound video plus audio channel using analog FM. The system has the return audio network via public telephone line but no return video or e-mail / data links. The system went to compressed video at Ku-band in 1995.

## 4.5 Comparison of The Educational Network Systems

In sections 4.2-4.4, three educational systems were described; the first is in Japan, the second is in Spain and the last one is at Virginia Tech. The first different feature of these three systems is that two are using VSAT technology, Japan's and Spain's systems use 1.0m-2.4m VSAT antennas for their remote sites but Virginia Tech's system larger antennas: a 7m transmit antenna and 2.4m receive antennas. The use of a full transponder at C-band became too expensive after 1994. For the modulation system, Japan's and Virginia Tech's system uses FM for video modulation which is an analog modulation. For the multiple access technique, Japan's system uses DAMA, Spain's system uses FDMA. Both Japan's and Spain's system have bi-directional satellite links, two-way video/audio. But Virginia Tech's system has one way video satellite and return audio via terrestrial phone lines which are often of poor quality, no selection of sites and a narrow band return link. The last difference between these systems is the compression system; Virginia Tech went to compressed video at Ku-band but the other systems have no compression system.

# **Chapter 5 THAICOM-1 : Educational VSAT Network Design**

## **5.1 THAICOM-1 VSAT Educational Network Design Considerations**

In chapter 4, three different educational systems were discussed. The author has already summarized and chosen the best features from these systems to use in the THAICOM-1 educational VSAT network. The features of the designed system are in Table 5.1.

The essential aspects of the network configuration using VSATs are shown in Fig.2.3, where a shared hub is located at the university in Bangkok. Each network is served by a 4.512 Mbps outbound TDM broadcast carrier from the hub and seven VSATs in the network employ seven 564 kbps DAMA carriers. The whole system is under the control of a network control center assumed to be co-located with the hub.

The overriding design issues are cost and reliability. The cost sensitive elements are:

**Table 5.1** Specifications of the THAICOM-1 VSAT Educational Network

| <b>Parameters</b>      | <b>Performance</b>                      |
|------------------------|---|
| No. of remote stations | 7 (up to 100 possible)                  |
| Satellite circuit      |   |
| Outbound transmissions |   |
| No. of carriers        | 1                                       |
| Access system          | Time division multiplexing              |
| Modulation             | Binary Phase Shift Keying (BPSK)        |
| Compression            | MPEG-2                                  |
| Data transmission rate | 4.512 Mbps                              |
| Inbound transmissions  |   |
| No. of carriers        | 8 (1 control channel + 7 data channels) |
| Access system          | SCPC DAMA                               |
| Modulation             | BPSK                                    |
| Compression            | MPEG-2                                  |
| Data transmission rate | 564 kbps                                |

- Antenna Size : 1.2-1.8m for majority of users and 2.4m for heavy rain rate area users.
- Solid State Power Amplifier (SSPA): 1-2 watt units are cost effective.
- Block vs. Convolutional Coding : Block codes are easy to implement but provide small coding gain; convolutional encoding/Viterbi soft decision decoding is complex but provides high gain and is currently cost competitive.
- Modulation : Three possible BPSK modulation schemes are compared below:

**Table 5.2** Comparison of BPSK Modulation Schemes (From D.Chakraborty, *IEEE Communications Magazine*[4].)

| <i>Modulation</i>         | <i><math>E_b/N_0</math> at <math>10^{-4}</math> BER(dB)</i> | <i>Implementation Margin (dB)</i> | <i>Recovery Loops</i> | <i>Acquisition Time</i> |
|---------------------------|---|-----------------------------------|-----------------------|-------------------------|
| Differential              | 9.3   | 1.2-1.7                           | Clock                 | Short                   |
| Coherent                  | 8.4   | 1.5-2.0                           | Clock, Carrier<br>AFC | Long                    |
| Differential-<br>Coherent | 8.8   | 1.5-2.0                           | Clock, Carrier<br>AFC | Long                    |

From cost, reliability and implementation considerations, differential BPSK is preferable.

- Multiple access : The multiple access technique which we chose is SCPC DAMA because this technique has been developed to overcome the complexity of existing VSAT networks using time division multiple access (TDMA) or spread spectrum and to simplify the transmission of data by using more straightforward techniques[1]. One of the most common high speed connectivity systems for satellite systems is SCPC, or single channel per carrier. For applications where high speed connectivity is required, but is not required all of the time, it may be more cost efficient to employ a Demand Assigned network topology rather than a full-time SCPC system. DAMA networks allow for the dynamic allocation and re-allocation of satellite power and bandwidth based upon the communications needs of the network users. Therefore, if a network has multiple sites with voice and data requirements, but doesn't have a 24 hour-a-day need for all sites to be in communication, a

smaller amount of satellite power and bandwidth can be shared by all users. This will lower the recurring monthly space-time costs. This is particularly important when there are a large number of VSAT in the network.

- Compression System : We choose MPEG-2 to be used in this design because if we compare MPEG-2 to H.261 and MPEG-1, MPEG-2 is the best choice for us [13]. Conceptually, both video compression standards, MPEG and CCITT H.261, are algorithmically similar, based on motion compensation and DCT (Discrete cosine transform) encoding. Unlike coding schemes for interactive video conferencing such as H.261, which is constrained to be a causal coding scheme, MPEG is targeted for storage and broadcasting applications. MPEG is a noncausal compression scheme where future frames can be used to code the current frame. The relaxation of causality allows MPEG to achieve better performance than the H.261 standard. Furthermore, Sam Lui[13] demonstrated that MPEG-2 provides better video quality over MPEG-1 regardless of the motion content.

The frequency which we chose for this system is Ku-band because our objective is just to provide tele-education in Thailand. The current trend in domestic satellite communications is toward Ku-band (12-14GHz), whereas international satellite communications media is basically C-band. Use of C-band transponders requires larger antennas which are more expensive and aesthetically less attractive. They are also more difficult to site because of their large size. Available transponder effective isotropic

radiated power (*EIRP*) from Ku-band transponders is at least 10-20 dB stronger than C-band transponders. The enhanced *EIRP* at Ku-band is, however, neutralized in part by the additional path loss when compared with the C-band system performance. The increased receive gain for a given size aperture at the earth station at Ku-band is available for system margin to combat the weather-related vagaries normally associated with Ku-band propagation. The 1.2m receive antenna system offers almost a threefold increase in traffic capacity at Ku-band when compared with the capacity availability from a C-band transponder [1]. The penalty, of course, is the rain attenuation and the consequent system outage.

## **5.2 The THAICOM-1 Educational VSAT System**

The THAICOM-1 Educational VSAT network has been designed using a single channel per carrier (SCPC) system linked with demand assigned multiple access (DAMA) technique for the inbound (VSAT to Hub) links. The SCPC DAMA VSAT network has been developed to overcome the complexity of VSAT networks using time division multiple access (TDMA) or spread spectrum and to simplify the transmission of data by using more straightforward techniques[1].

A SCPC DAMA network provides the user with a bi-directional data channel on demand from a pool of channels. The VSAT to hub (or inbound link) is a SCPC-BPSK 256 kbps link while the outbound or hub to VSAT link is a TDM-BPSK 2.048 Mbps link (Fig. 5.2)

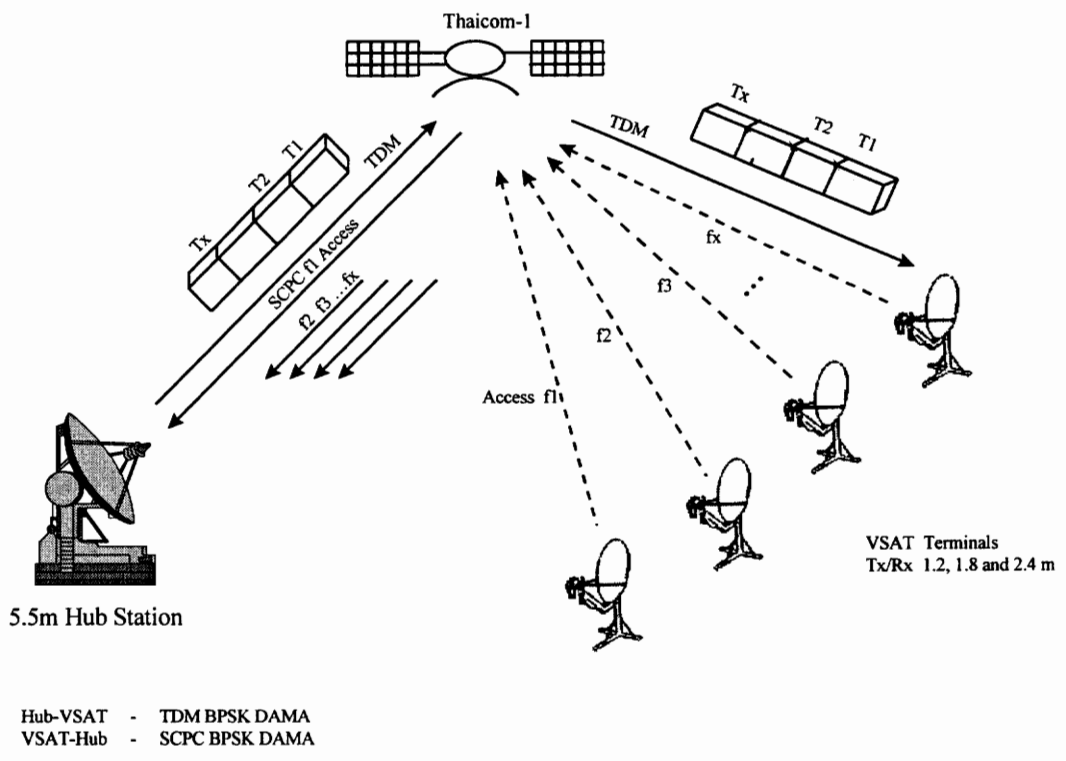

**Figure 5.2** VSAT Network Star Configuration ( From J. Everett, *VSATs: Very Small Aperture Terminals*[1].)

### 5.2.1 SCPC DAMA Network

The network provides a bi-directional data channel which is economic in the use of satellite bandwidth and VSAT power. Bandwidth efficiency results from the need to utilize only sufficient channels to support the VSATs and bandwidth can be expanded as the VSAT population increases.

The SCPC DAMA network utilizes transponder bandwidth in an efficient manner and provides simple channel assignment. In this design, the SCPC DAMA network comprises  $8 \times 256$  kbps inbound channels (7 data channels + 1 control channel) and one

2.048 Mbps outbound channel. By this design, we allow only one SCPC channel (inbound) access at a time via DAMA( See more details of SCPC DAMA in [1].) A data channel for E-mail between sites and document delivery can be added, if needed.

## **5.2.2 VSAT Hardware**

- **Outdoor Equipment**

The THAICOM SCPC DAMA VSAT terminal operates in the 12-14 GHz frequency band. The VSAT terminal comprises RF equipment, antenna, external and internal up and downconverters. The RF up and downconverters are fully synthesized and utilize a double conversion technique with the intermediate frequency 70 MHz for Ku-band as indicated in Fig. 5.3. The external equipment consists of the antenna system and electronic package. The antenna diameter we use in this design has three sizes, 1.2m, 1.8m and 2.4m. The up and down converters are both supplied from the same phase-locked oscillator. The outdoor unit also contains a solid state power amplifier(SSPA), the transmit amplifier is 2W.

- **Indoor Equipment**

The indoor unit contains the MPEG-2 coder & decoder, FEC coder & decoder, and DBPSK modulator & demodulator. The VSAT terminal utilizes SCPC transmission with a 256 kbps information rate.

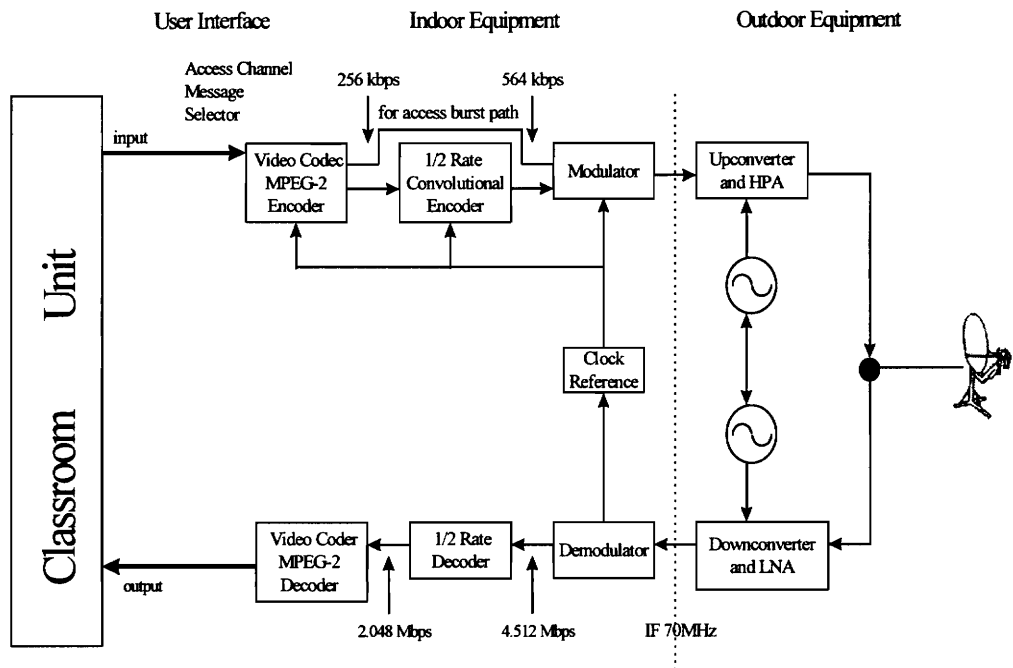

**Figure 5.3** Block Diagram of Proposed VSAT system

The demodulator at the VSAT recovers a 2.048 MHz clock providing a signal reference back to the hub clock. The MPEG-2 encodes video, audio, and user data inputs, and multiplexes these inputs into a digital data stream for transmission over the satellite. Before multiplexing the data, the MPEG-2 encoder compresses the data to reduce the number of bits needed to represent the original video and audio signals.

After multiplexing, a 256-kbps data stream is input to the half rate FEC encoder for transmission to the hub. The half rate FEC encoder and

DBPSK modulator generate the final channel rate of 564 kbps, modulated onto a predefined carrier close to 70 MHz. The MPEG-2 decoder receives the frame 2.048 Mbps data along with the recovered 2.048 MHz clock from the VSAT demodulator, demultiplexes the digital video, audio and user data information, and then decodes it for output to a peripheral device.

### **5.2.3 Hub Equipment**

- **Earth Station Equipment**

The hub earth station at Ku-band, shown in Fig. 5.4, comprises a 5.5 diameter antenna, LNA and high stability up and down converters. The hub earth station provides the VSAT with a master clock for locking both the up and down converters. This signal is also passed across to the modulator and FEC encoder. The earth station equipment also contains a Traveling wave tube amplifier (TWTA), the transmit amplifier is 5 W.

- **Hub Equipment**

As in the VSAT system, the MPEG-2 codec was chosen in the hub system. The seven 256 kbps data channels plus an access channel are multiplexed together to form a TDM frame. Before multiplexing the data, the codec compresses the data to reduce the number of bits needed to represent the original video and audio signals. After multiplexing, the

2.048 Mbps data stream is input to the half rate FEC decoder for transmission to the remotes. The hub modem equipment consists of modulator and demodulator.

The hub demodulators comprise two variants: the access channel demodulator and the message channel demodulator. The access channel demodulator differs from the message demodulator as no FEC is used in this channel. Following demodulation the half rate FEC decoder decodes the data stream at 256 kbps information rate. This signal is finally transmitted to the decoder in the MPEG-2 decoder.

The hub modulator accepts the 2.048 Mbps TDM data from the Mpeg-2 encoder. The unit then applies forward error correction, encodes the signal and modulates the data onto a 70 MHz IF carrier signal to provide a 4.512 Mbps DBPSK signal which is routed to the hub RF upconverter.

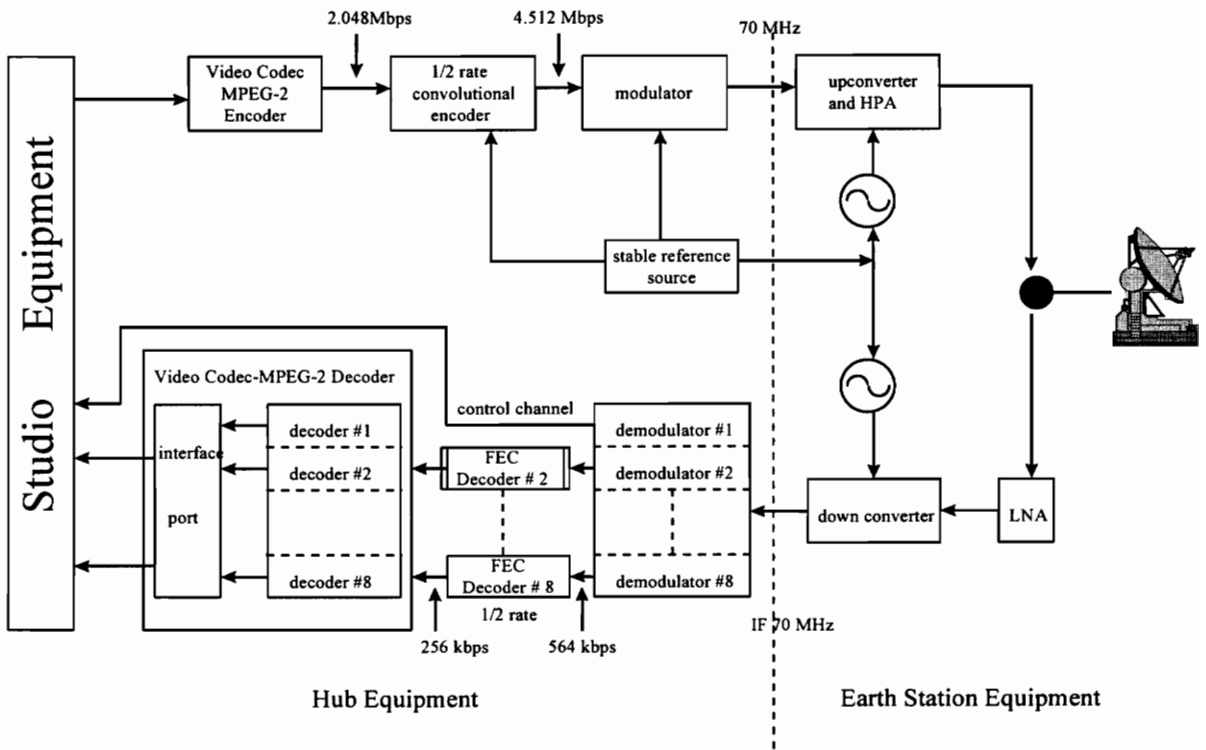

**Figure 5.4** Block Diagram of Proposed Hub System

### 5.3 Link Budgets for Educational VSAT system

In order to design a highly reliable and unattended Ku-band radio system for VSAT applications covering the entire nation of Thailand, a number of constraints and design issues have been examined in depth in Table 5.3 and 5.4.

From the results of Table 5.4, link margin could be increased by use of uplink power control of 10 dB at the hub station which looks worthwhile in this case. This means that uplink rain attenuation is compensated for by increasing the transmit earth station power at the hub by the same amount, or the maximum allowable amount, without any time delay [16]. More link budgets appear in Appendix C.

**Table 5.3** System Parameters Used in the Link Design

|                                  |  |
|----------------------------------|--|
| <b>Carriers</b>                  |  |
| Outbound:                        | 1 TDM frame  |
| Inbound:                         | 8 SCPC DAMA Channels (1 Control Channel + 7 VSAT Data Channel)   |
| Information Rate:                | 2.048 Mbps for TDM Outbound Carrier and 256 kbps for SCPC DAMA Inbound Carriers  |
| Data Rate Including Overhead*:   | 2.25 Mbps for TDM Outbound Carrier and 282 kbps for SCPC DAMA Inbound Carriers   |
| Transmission Rate*:              | 4.512 Mbps for TDM Outbound Carrier and 564 kbps for SCPC DAMA Inbound Carriers  |
| Occupied Bandwidth*:             | 2.71 MHz for TDM Outbound Carrier and 338 kHz for SCPC DAMA Inbound Carriers   |
| Allocated Bandwidth*:            | 3.173 MHz for TDM Outbound Carrier and 427.5 kHz for SCPC DAMA Inbound Carriers  |
| Modulation:                      | BPSK   |
| Coding:                          | ½ Rate FEC Convolutional Code Soft Decision, Viterbi 3-bit Soft Decision   |
| Compression:                     | MPEG-2   |
| Required $E_b/N_0$ :             | 11 dB (for BER of about $10^{-7}$ )  |
| <b>Satellite and Transponder</b> |  |
| Satellite:                       | THAICOM-1, GEO Type  |
| Satellite Location:              | 78.5° East Longitude   |
| Transponder Type:                | Ku-Band  |
| Transponder Usable Bandwidth:    | 54 MHz   |
| Transponder Operation:           | 9 dB input backoff<br>3 dB output backoff  |
| <b>Hub</b>                       |  |
| Location:                        | Bangkok (Rain Zone = N, Satellite $G/T = 9.4$ dB/K, $EIRP = 53.5$ dBW)   |
| TWTA Transmit Power:             | 5 Watt   |
| Antenna Diameter:                | 5.5 m  |
| Receive $G/T$ :                  | 32.6 dB/K  |
| Transmit Antenna Gain:           | 56.0 dB  |
| Receive Antenna Gain:            | 54.6 dB  |
| <b>VSATs</b>                     |  |
| Location:                        | All Over Thailand <ol style="list-style-type: none"> <li>1. Ban Mae La Luang (Rain Zone = N, Satellite <math>G/T = 8.6</math> dB/K, <math>EIRP = 51.0</math> dBW)</li> <li>2. Chiang Mai (Rain Zone = N, Satellite <math>G/T = 9.2</math> dB/K, <math>EIRP = 51.6</math> dBW)</li> <li>3. Ban Chai Buri ( Rain Zone = N, Satellite <math>G/T = 9.6</math> dB/K, <math>EIRP = 52.0</math> dBW)</li> <li>4. Ban Khemma Marat (Rain Zone = N, Satellite <math>G/T = 9.2</math> dB/K, <math>EIRP = 51.8</math> dBW)</li> <li>5. Ban Khlong Makham (Rain Zone = N, Satellite <math>G/T = 9.6</math> dB/K, <math>EIRP = 53.1</math> dBW)</li> <li>6. Phuket (Rain Zone = P, Satellite <math>G/T = 10.1</math>, <math>EIRP = 52.3</math> dBW)</li> <li>7. Rangae (Rain Zone = P, Satellite <math>G/T = 8.1</math>, <math>EIRP = 51.0</math> dBW)</li> </ol> |
| SSPA Transmit Power:             | 2 Watt   |
| Antenna Diameters:               | 1.2, 1.8, 2.4 m  |
| Receive $G/T$ s:                 | 19.3, 22.9, 25.4 dB/K  |
| Transmit Antenna Gains:          | 42.7, 46.2, 48.7 dB  |
| Receive Antenna Gains:           | 41.3, 44.9, 47.4 dB  |

\* The carrier parameters for this design are based on INTELSAT's International Business Service (IBS)-type carriers [12].

**Table 5.4** Link Analysis: Bangkok Hub to Ban Mae La Luang (VSAT#1) Link, Hub transmits one coded 4.512 Mbps TDM carrier (outbound) and receives 8 coded 564 kbps SCPC DAMA carriers (inbound). Use Full Transponder Power of THAICOM-1, in Clear Air.

|   | Hub-to-VSAT#1          |                        |                        | VSAT#1-to-Hub        |                        |                        |
|---|------------------------|------------------------|------------------------|----------------------|------------------------|------------------------|
|   | Ø 1.2m                 | Ø 1.8m                 | Ø 2.4m                 | Ø 1.2m               | Ø 1.8m                 | Ø 2.4m                 |
| <b>Uplink (14GHz)</b>   |                        |                        |                        |                      |                        |                        |
| 1. Earth Station <i>EIRP</i> , (dBW)                            |                        | 63                     |                        | 45.7                 | 49.2                   | 51.7                   |
| 2. Uplink Path Loss, (dB)                                       |                        | 207                    |                        |                      | 207                    |                        |
| 3. Atmospheric Loss (Clear Sky), (dB)                           |                        | 0.2                    |                        |                      | 0.2                    |                        |
| 4. Antenna Pointing Loss, (dB)                                  |                        | 0.5                    |                        |                      | 0.2                    |                        |
| 5. Satellite <i>G/T</i> , (dB/K)                                |                        | 9.4                    |                        |                      | 8.6                    |                        |
| 6. Uplink <i>C/No</i> , (dB)                                    |                        | 93.3                   |                        | 75.5                 | 79                     | 81.5                   |
| <b>Downlink (12GHz)</b>   |                        |                        |                        |                      |                        |                        |
| 7. Transponder <i>EIRP</i> /carrier with 3 dB back-off, (dBW)   |                        | 48                     |                        |                      | 41.5                   |                        |
| 8. Downlink Path Loss, (dB)                                     |                        | 205.5                  |                        |                      | 205.5                  |                        |
| 9. Atmospheric Loss (Clear Sky), (dB)                           |                        | 0.2                    |                        |                      | 0.2                    |                        |
| 10. Antenna Pointing Loss, (dB)                                 |                        | 0.2                    |                        |                      | 0.5                    |                        |
| 11. Receiver <i>G/T</i> , (dB/K)                                | 19.3                   | 22.9                   | 25.4                   |                      | 32.6                   |                        |
| 12. Downlink <i>C/No</i> , (dB)                                 | 90                     | 93.6                   | 96.1                   |                      | 96.5                   |                        |
| <b>Uplink and Downlink</b>                                      |                        |                        |                        |                      |                        |                        |
| 13. Overall <i>C/No</i> , (dB)                                  | 88.3                   | 90.4                   | 91.5                   | 75.5                 | 78.9                   | 81.4                   |
| 14. Encoded Information Rate, (dBHz)                            |                        | 66.5                   |                        |                      | 57.5                   |                        |
| 15. User Information Rate, (dBHz)                               |                        | 63.1                   |                        |                      | 54.1                   |                        |
| 16. <i>C/N</i> Measured in Encoded Signal Bandwidth, (dB)       | 21.8                   | 23.9                   | 24.9                   | 18.0                 | 21.4                   | 23.9                   |
| 17. Implementation Margin, (dB)                                 |                        | 2                      |                        |                      | 2                      |                        |
| 18. <i>Et/No</i> , (dB)   | 16.8                   | 18.9                   | 19.9                   | 13.0                 | 16.4                   | 18.9                   |
| 19. <i>Eb/No</i> Measured in Information Signal Bandwidth, (dB) | 20.2                   | 22.3                   | 23.4                   | 16.4                 | 19.8                   | 22.3                   |
| 20. Clear Sky Bit Error Rate (BER)                              | $1.01 \times 10^{-10}$ | $1.18 \times 10^{-11}$ | $4.12 \times 10^{-12}$ | $5.2 \times 10^{-9}$ | $1.49 \times 10^{-10}$ | $1.23 \times 10^{-11}$ |
| 21. Require <i>Eb/No</i> at $10^{-7}$ (dB)                      |                        | 11                     |                        |                      | 11                     |                        |
| 22. Link Margin, (dB)   | 9.2                    | 11.3                   | 12.4                   | 5.4                  | 8.8                    | 11.3                   |

A detailed description of each line entry of the link budgets is given below.

#### 5.3.2.1 Line 1 : Earth Station EIRP

$$EIRP = 10 \log P_t G_t \quad \text{dBW}$$

where

$P_t$  = earth station amplifier transmit power

$G_t$  = earth station antenna gain

#### 5.3.2.2 Line 2 : Uplink path loss

Uplink path loss (between isotropic antenna)

$$\frac{\lambda_u^2}{(4\pi d_u)^2} \quad \text{or} \quad 20 \log \left( \frac{\lambda_u}{4\pi d_u} \right) \quad \text{dB}$$

$\lambda_u$  = wavelength of uplink signal (m), typically 0.021m at 14 GHz

$d_u$  = earth station to satellite range on uplink (m); typically 36,000 km for a geostationary

satellite and an earth station in Thailand.

#### 5.3.2.3 Line 3 : Atmospheric loss

Residual atmospheric loss under clear sky conditions due to water vapor and oxygen absorption = 0.2 dB through a typical earth station/satellite path at 14 GHz.

#### 5.3.2.4 Line 4 : Antenna pointing loss

Typically  $\leq 0.2$  dB for hub

$\leq 0.5$  dB for fixed antenna

#### 5.3.2.5 Line 5 : Satellite G/T



**Table 5.5** THAICOM-1 Worst Case Performance for Ku-band *EIRP* and *G/T* (From [9].)

| City                     | <i>EIRP</i><br>(dBW) | <i>G/T</i><br>(dBW) |
|--------------------------|----------------------|---------------------|
| <b>Bangkok</b>           | 53.5                 | 9.4                 |
| <b>Ban Mae La Luang</b>  | 51.0                 | 8.6                 |
| <b>Chiang Mai</b>        | 51.6                 | 9.2                 |
| <b>Ban Chai Buri</b>     | 52.0                 | 9.6                 |
| <b>Ban Khemma Marat</b>  | 51.8                 | 9.2                 |
| <b>Ban Khlong Makham</b> | 53.1                 | 9.6                 |
| <b>Phuket</b>            | 52.3                 | 10.1                |
| <b>Rangae</b>            | 51.0                 | 8.1                 |

**5.3.2.8** *Line 8* : Downlink path loss

$$\frac{\lambda_u^2}{(4\pi d_u)^2} \text{ or } 20\log\left(\frac{\lambda_u}{4\pi d_u}\right) \text{ dB}$$

$\lambda_u$  = wavelength of downlink signal (m)

$d_u$  = earth station to satellite range on uplink (m )

**5.3.2.9** *Line 9* : Atmospheric loss

(See Section 5.3.2.3)

**5.3.2.10** *Line 10* : Antenna pointing loss

(See Section 5.3.2.4)

**5.3.2.11** *Line 11* : Receiver *G/T*

$$\text{Receiver } G/T = \frac{G_E}{T_{ESr}} \text{ K}^{-1} \text{ or } 10\log\left(\frac{G_E}{T_E}\right) \text{ dB/K}$$

where

$G_E$  = gain of earth station receive antenna

$T_{ES}$  = earth station system noise temperature.

### 5.3.2.12 Line 12 : Downlink $C/N_0$

(See Section 5.3.2.9).

Downlink  $C/N_0$  is given by:

$$C / N_0 = (\text{line12} - \text{line13} - \text{line14} - \text{line15} + \text{line16} + 228.6) \text{ dB Hz}^{-1}$$

### 5.3.2.13 Line 13 : Overall $C/N_0$

$$\text{Overall } C / N_0 = \left[ \left( \frac{C}{N_0} \right)_{up}^{-1} + \left( \frac{C}{N_0} \right)_{down}^{-1} \right] \text{ dB Hz}^{-1}$$

### 5.3.2.14 Line 14 : Encoded information rate

Encoded information rate is the user information signal rate increased by the application of forward error correction and is measured in bit/s or dB Hz if expressed as a decibel value.

### 5.3.2.15 Line 15 : User information rate

Rate of useful information delivered to user.

### 5.3.2.16 Line 16 : $C/N$ in encoded signal bandwidth

$C/N$  is the carrier to noise ratio and is given by

$$\frac{C}{N} = \frac{C}{N_0} \times \frac{1}{\text{encoded information rate}}$$

or

$$\frac{C}{N} = \frac{C}{N_0} - 10 \log(\text{encoded information rate}) \text{ dB}$$

This assumes that encoded information rate equals to the receiver noise bandwidth. It is true for BPSK with ideal filter, not in any other case.

### 5.3.2.17 Line 17 : Implementation margin

This largely accounts for non-ideal performance of BPSK demodulator: Timing Jitter, intersymbol interference (from real filters rather than raised cosine), etc. 2 dB for differential BPSK would be a good value to use.

### 5.3.2.18 Line 18 : $E_t/N_0$

$E_t/N_0$  = energy per transmitted bit (i.e. both an information bit or a parity bit) to noise power spectral density ratio.

$$\frac{E_t}{N_o} = \frac{C}{N_o} \times \frac{1}{\text{encoded information rate}} \times \frac{1}{\log_2 m}$$

where  $m$  = number of transmitted bits per symbol transmitted.

Note :  $\log_2 m = 1$  for  $m = 2$  (binary system)

$\log_2 m = 2$  for  $m = 4$  (4 level system)

$\log_2 m = 3$  for  $m = 8$  (8 level system)

### 5.3.2.19 Line 19 : $E_b/N_0$

$E_b/N_0$  = energy per information bit to noise power spectral density:

$$\frac{E_b}{N_o} = \frac{E_t}{N_o} \times \frac{\text{encoded information rate}}{\text{information rate}}$$

Note: information-rate/encoded-information-rate is often called coding rate.

### 5.3.2.20 Line 20 : Bit Error Rate (BER)

$$BER = \frac{1}{2} \operatorname{erfc} \left( \sqrt{\frac{E_b}{N_o}} \right)$$

where  $E_b/N_0$  = energy per information bit to noise power spectral density

**5.3.2.21 Line 21: Required  $E_b/N_0$  at  $10^{-7}$  BER**

|  |         |
|--|---------|
| Theoretical $E_b/N_0$ at $10^{-7}$ BER                             | ~6.2 dB |
| Modem/Codec Implementation Margin                                  | 1.7 dB  |
| $E_b/N_0$ Margin Due to day-to-day Fluctuation in Transponder Gain | 1.5 dB  |
| $E_b/N_0$ Margin Due to Transponder EIRP Uncertainty               | 1.0 dB  |
| Overall Amplitude Group Delay Distortion Margin                    | 0.3 dB  |
| Receive $G/T$ Margin Due to LNA Aging and Feed Corrosion           | 0.3 dB  |
| Total $E_b/N_0$ Required for the worst case design                 | 11 dB   |

This design allows 4.8 dB of system margin over the theoretical minimum  $E_b/N_0$  required to achieve a BER of  $10^{-7}$  using BPSK and half rate coding. As a result, the threshold  $E_b/N_0$  value is 11 dB, rather than the theoretical value of 6.2 dB often quoted in the literature. If the transponder carriers only the educational VSAT network systems, better stability of  $EIRP$  in the transponder should be achieved allowing a lower  $E_b/N_0$  threshold to be used.

## **Chapter 6 Performance Analysis of THAICOM-1 Educational VSAT Network**

The purpose of this chapter is to examine the VSAT service quality and its economic impact. By service quality, it means parameters such as link bit error rate (*BER*) and system availability. The system availability is a composite factor, comprising satellite link availability and earth station equipment factors. Satellite link availability in Ku-band is principally governed by the rain attenuation margin as explained in Chapter 3. The larger the up-path rain margin assigned, the bigger the HPA or antenna size becomes, which increases the earth station installation cost. On the other hand, the larger the down-path rain margin assigned, the larger the required carrier satellite *EIRP* needed for a fixed antenna size and specific *BER*, which translates into less efficient utilization of the transponder resources. In addition, the better the *BER* performance offered, the less efficient the transponder utilization will be. For example, with half rate soft decision

FEC, a  $BER$  of  $10^{-7}$  may need approximately 0.5 dB more  $E_b/N_0$  as compared to the  $E_b/N_0$  required for the  $BER$  of  $10^{-6}$ , which means a reduction of approximately 12 percent in space segment equipment availability; a fully redundant system may yield an availability close to 0.9999, and a single-thread system may yield an availability  $\leq 0.9999$ [3]. It will be clear that the overall system availability, link  $BER$  and transmission rate will impact and be impacted upon by the earth station cost and transponder utilization efficiency. Since the availability of a link is the percentage of time that information can be transmitted and received with acceptable quality, we first quantify the information quality. Next, we discuss the tradeoffs of transponder power-bandwidth utilization efficiency and earth station size. Finally, we provide a performance analysis example and draw conclusions based on the analysis. This parametric study is based upon the THAICOM-1 satellite system with a fixed 5.5m hub station and remote terminal antenna size ranging from 1.2m to 2.4m.

## 6.1 Information Quality

The quality of transmitted information is objectively specified in terms of bit-error rate ( $BER$ ) for digital signals.  $BER$  is related to carrier-to-equivalent-noise-spectral-density ratio ( $C/N_0$ ) at the demodulator/decoder input.

For digital information, the  $BER-C/N_0$  relationship is a function of modulation and coding schemes used. It is often supplied by the manufacturer in terms of  $BER$  and  $E_b/N_0$  as the result of IF back-to-back measurements.  $E_b/N_0$  is energy-per-(uncoded)bit-

per-noise-density ratio which is directly related to  $C/N_0$  in dBHz and the (uncoded) bit rate  $R$  in bps by the equations in section 5.3.2.18-5.3.2.20.

## **6.2 Transponder Power-Bandwidth and Earth Station Size Tradeoffs**

Bandwidth and power requirements vary greatly. Transponder bandwidth, power and earth station size determine the video signal quality, and there are technical as well as cost trade-offs between them. Typically, billing for transponder usage is based on the larger of the bandwidth or power usage.

Degradation due to multi-carrier intermodulation is caused by amplitude and phase nonlinearity in the transponder final power amplifier (traveling wave tube amplifier - TWTA) when operated in a quasi-linear region. The whole transponder may not necessarily be leased by a single network, and under this condition other users must be protected. On the other hand, if a full transponder is leased by a single entity, then the carriers can be arranged in a prescribed frequency plan to reduce the effect of intermodulation distortion, and the transponder can be operated closer to saturation provided sufficient bandwidth redundancy is available to implement the frequency plan mentioned above. However, if the full bandwidth is utilized with equally spaced carriers, the intermodulation noise density tends to peak around the midband of the transponder. This peak value may be as high as 6 dB over the mean value across the transponder band. Considering the above scenarios, we assume an output back-off of 3dB and a

corresponding input back-off of 9 dB for this study, which is enough because we use the full transponder power for our system. However, in a specific system, the back-off should be optimized taking into account up-path, down-path, and intermodulation noise as a function of the transponder back-off and any improvement in intermodulation noise due to frequency planning if applicable.

For a fixed size antenna, the up-path margin can be accommodated by an increased size of the final power amplifier. On the other hand, for a fixed size antenna and a given front-end receive amplifier, the down-path margin can only be accommodated by increased satellite *EIRP*, which translates into a less efficient utilization of the space segment resources. Downlink power from the satellite is the main parameter for determining the size of the earth station antenna. The higher the power, the smaller the antenna that can be used; this means that we can reduce the cost of our system. In general, the capital cost of the earth stations dominate the economics of the system [15]. Anyway, we still have to think about the rain margin of each size of VSAT since Thailand is a country in the highest rain zone. Back in Chapter 3, initial examination has shown that a 1.2m antenna for the remote terminal is somewhat marginal, and therefore we choose a 1.8m antenna for the remote terminal for zone N, except for zone P where the rain margin requirements are higher (refer to section 6.4). Examining Fig. 3.10, we observe that at, for example, 0.2 percentage of year, the differential up-path and down-path margin between zone N and P is approximately 1 dB.

A 2.4 m antenna for the southern part of Thailand (zone P) remote terminals will enhance the transmit and receive gain by  $10 \log (2.4/1.8)^2 = 2.5$  dB over the gain of a 1.8m antenna, which will adequately compensate for the different rain margin between zone N and P.

### **6.3 Performance Analysis of the Designed-VSAT Network**

Consider the educational VSAT network for a corporation with the central university located in Bangkok and remote terminals throughout Thailand. System performance is detailed in Tables 6.1 and 6.2 VSAT Network Performance and the link budget of the system is shown in Tables 5.3 through 5.4 in Chapter 5, including Table 3.4 uplink and downlink margins for the rain effects in Chapter 3. Table 6.3a and 6.3b summarizes the characteristics of the links between Bangkok and the VSAT terminals. Because of the use of very small antennas and low power transmitters, a VSAT network is inherently a power-limited network [15]. Therefore the satellite capacity usage is very inefficient. From the system design in Chapter 5, the throughput is 4.512 Mbps with 54 MHz transponder bandwidth, thus the transponder efficiency is 0.084 bps/Hz. For the 4.512 Mbps bit rate, a 10 MHz transponder would suffice. This represents a bandwidth saving factor of 5.4. However, the transponders of THAICOM-1 have a bandwidth of 54 MHz, so the system is power limited, not bandwidth limited.

We show the performance for three cases of transponder power utilization; full, half and quarter transponder power in Table 6.1 and 6.2 for the Hub-to-VSAT#1 and

VSAT#1-to-Hub link. Table 6.1 is in clear air and Table 6.2 includes rain effects. It can be observed that we can use 1.8m and 2.4m VSAT antennas because they provide sufficient link margin and acceptable *BER* in the system for both cases of clear air and rain conditions. We can use a 1.2 m VSAT antenna satisfactorily only in clear air.

Figure 6.1 through 6.4 and Figure in Appendix C show the performance for *BER* and link margin versus percentage of time, under rain condition at a downlink for Hub-to-VSAT links and at the uplinks for VSAT-to-Hub links of the Educational VSAT network using full transponder power. A summary of these figures is in Table 6.3a and 6.3b.

Table 6.3b shows that VSAT networks can be designed to provide the network performance desired. This includes taking into account the degradation effect of rain. An availability of greater than 98.5% ( at  $BER \leq 10^{-7}$ ) for the outbound link and 95.0% for the inbound links can be achieved with 2.4 meter or 1.8m antennas in all but the most heavy rain regions(zone P) and worst satellite coverage areas. Even in these areas, high availability for data links can be achieved by using increased satellite transponder power per carrier. This can be accomplished without causing excessive interference to other systems by using the full transponder power utilization, but with less transponder efficiency.

**Table 6.1** VSAT Network Performance with Changing Transponder Power and VSAT Antenna Size at Ban Mae La Luang in Clear Air

| Transponder Power, (dBW)<br>Hub-to-Vsat#1 | Transponder Power, (dBW)<br>Vsat#1-to-Hub | Hub-to-Vsat#1       |             |                     |             |                     |             | Vsat#1-to-Hub      |             |                     |             |                     |             |
|---|---|---------------------|-------------|---------------------|-------------|---------------------|-------------|--------------------|-------------|---------------------|-------------|---------------------|-------------|
|   |   | Ø 1.2m              |             | Ø 1.8m              |             | Ø 2.4m              |             | Ø 1.2m             |             | Ø 1.8m              |             | Ø 2.4m              |             |
|   |   | BER clear air       | Margin (dB) | BER clear air       | Margin (dB) | BER clear air       | Margin (dB) | BER clear air      | Margin (dB) | BER clear air       | Margin (dB) | BER clear air       | Margin (dB) |
| Full : 48                                 | 41.5                                      | 1×10 <sup>-10</sup> | 9.2         | 1×10 <sup>-11</sup> | 11.3        | 4×10 <sup>-12</sup> | 12.4        | 5×10 <sup>-9</sup> | 5.4         | 1×10 <sup>-10</sup> | 8.8         | 1×10 <sup>-11</sup> | 11.3        |
| Half : 45                                 | 38.5                                      | 1×10 <sup>-9</sup>  | 7.0         | 7×10 <sup>-11</sup> | 9.6         | 2×10 <sup>-11</sup> | 11.1        | 5×10 <sup>-9</sup> | 5.3         | 2×10 <sup>-10</sup> | 8.8         | 1×10 <sup>-11</sup> | 11.2        |
| Quarter : 42                              | 35.5                                      | 1×10 <sup>-8</sup>  | 4.4         | 7×10 <sup>-10</sup> | 7.5         | 9×10 <sup>-11</sup> | 9.3         | 6×10 <sup>-9</sup> | 5.3         | 2×10 <sup>-10</sup> | 8.6         | 2×10 <sup>-11</sup> | 10.9        |

**Table 6.2** VSAT Network Performance with Changing Transponder Power and VSAT Antenna Size at Ban Mae La Luang in Rain Condition

| Transponder Power, (dBW)<br>% of year | BER with rain         |                       |                       |                      |                       |                       | Link Margin , (dB) |       |       |               |       |       |
|---------------------------------------|-----------------------|-----------------------|-----------------------|----------------------|-----------------------|-----------------------|--------------------|-------|-------|---------------|-------|-------|
|                                       | Hub-to-Vsat#1         |                       |                       | Vsat#1-to-Hub        |                       |                       | Hub-to-Vsat#1      |       |       | Vsat#1-to-Hub |       |       |
|                                       | Ø1.2m                 | Ø1.8m                 | Ø2.4m                 | Ø1.2m                | Ø1.8m                 | Ø2.4m                 | Ø1.2m              | Ø1.8m | Ø2.4m | Ø1.2m         | Ø1.8m | Ø2.4m |
| Full :                                | $4.6 \times 10^{-10}$ | $3.6 \times 10^{-11}$ | $9.3 \times 10^{-12}$ | $2.2 \times 10^{-8}$ | $6.7 \times 10^{-10}$ | $5.8 \times 10^{-11}$ | 7.8                | 10.2  | 11.6  | 4.0           | 7.5   | 9.9   |
| Hub-to-Vsat#1=48                      | $1.5 \times 10^{-9}$  | $9.5 \times 10^{-11}$ | $2.0 \times 10^{-11}$ | $7.8 \times 10^{-8}$ | $2.3 \times 10^{-9}$  | $2.0 \times 10^{-10}$ | 6.6                | 9.3   | 10.8  | 2.8           | 6.2   | 8.7   |
| Vsat#1-to-Hub=41.5                    | $8.4 \times 10^{-9}$  | $3.9 \times 10^{-10}$ | $6.4 \times 10^{-11}$ | $5.1 \times 10^{-7}$ | $1.5 \times 10^{-8}$  | $1.3 \times 10^{-9}$  | 4.9                | 7.9   | 9.7   | 0.9           | 4.4   | 6.9   |
| 0.03                                  | $1.2 \times 10^{-7}$  | $4.3 \times 10^{-9}$  | $5.1 \times 10^{-10}$ | $1.2 \times 10^{-5}$ | $3.5 \times 10^{-7}$  | $3.0 \times 10^{-8}$  | 2.3                | 5.6   | 7.6   | -2.1          | 1.4   | 3.8   |
| 0.01                                  | $2.6 \times 10^{-6}$  | $7.4 \times 10^{-8}$  | $7.2 \times 10^{-9}$  | $9.4 \times 10^{-4}$ | $2.4 \times 10^{-5}$  | $2.0 \times 10^{-6}$  | -0.6               | 2.8   | 5.1   | -6.2          | -2.7  | -0.2  |
| 0.003                                 | $4.6 \times 10^{-4}$  | $1.1 \times 10^{-5}$  | $8.5 \times 10^{-7}$  | -                    | $1.8 \times 10^{-2}$  | $1.2 \times 10^{-3}$  | -5.5               | -2.0  | 0.4   | -12.2         | -8.7  | -6.3  |
| 0.001                                 | $2.6 \times 10^{-1}$  | $3.0 \times 10^{-3}$  | $2.0 \times 10^{-4}$  | -                    | -                     | -                     | -10.8              | -7.2  | -4.7  | -19.3         | -15.8 | -13.4 |
| Half :                                | $5.8 \times 10^{-9}$  | $2.9 \times 10^{-10}$ | $4.9 \times 10^{-11}$ | $2.2 \times 10^{-8}$ | $6.7 \times 10^{-10}$ | $5.8 \times 10^{-11}$ | 5.3                | 8.2   | 9.9   | 4.0           | 7.4   | 9.8   |
| Hub-to-Vsat#1=45                      | $2.3 \times 10^{-8}$  | $9.3 \times 10^{-10}$ | $1.3 \times 10^{-10}$ | $7.8 \times 10^{-8}$ | $2.3 \times 10^{-9}$  | $2.0 \times 10^{-10}$ | 4.0                | 7.1   | 8.9   | 2.8           | 6.2   | 8.6   |
| Vsat#1-to-Hub=38.5                    | $1.4 \times 10^{-7}$  | $4.9 \times 10^{-9}$  | $5.9 \times 10^{-10}$ | $5.1 \times 10^{-7}$ | $1.5 \times 10^{-8}$  | $1.3 \times 10^{-9}$  | 2.2                | 5.4   | 7.5   | 0.9           | 4.4   | 6.7   |
| 0.03                                  | $2.4 \times 10^{-6}$  | $6.8 \times 10^{-8}$  | $6.7 \times 10^{-9}$  | $1.2 \times 10^{-5}$ | $3.5 \times 10^{-7}$  | $3.0 \times 10^{-8}$  | -0.5               | 2.9   | 5.1   | -2.1          | 1.3   | 3.7   |
| 0.01                                  | $5.6 \times 10^{-5}$  | $1.4 \times 10^{-6}$  | $1.2 \times 10^{-7}$  | 0.00094              | $2.4 \times 10^{-5}$  | $2.0 \times 10^{-6}$  | -3.5               | 0     | 2.3   | -6.2          | -2.8  | -0.4  |
| 0.003                                 | $1.2 \times 10^{-2}$  | $2.4 \times 10^{-4}$  | $1.8 \times 10^{-5}$  | -                    | 0.01781               | 0.00122               | -8.5               | -4.9  | -2.5  | -12.2         | -8.8  | -6.4  |
| 0.001                                 | -                     | $1.0 \times 10^{-1}$  | $5.2 \times 10^{-3}$  | -                    | -                     | -                     | -13.8              | -10.2 | -7.7  | -19.3         | -15.9 | -13.5 |
| Quarter :                             | $9.5 \times 10^{-8}$  | $3.4 \times 10^{-9}$  | $4.2 \times 10^{-9}$  | $2.4 \times 10^{-8}$ | $7.7 \times 10^{-10}$ | $7.5 \times 10^{-11}$ | 2.6                | 5.8   | 7.8   | 3.9           | 7.2   | 9.5   |
| Hub-to-Vsat#1=42                      | $4.1 \times 10^{-7}$  | $1.3 \times 10^{-8}$  | $1.4 \times 10^{-9}$  | $8.4 \times 10^{-8}$ | $2.7 \times 10^{-9}$  | $2.6 \times 10^{-10}$ | 1.2                | 4.5   | 6.6   | 2.7           | 6.0   | 8.3   |
| Vsat#1-to-Hub=35.5                    | $2.8 \times 10^{-6}$  | $8.0 \times 10^{-8}$  | $7.7 \times 10^{-9}$  | $5.5 \times 10^{-7}$ | $1.7 \times 10^{-8}$  | $1.6 \times 10^{-9}$  | -0.7               | 2.7   | 5.0   | 0.9           | 4.2   | 6.5   |
| 0.03                                  | $5.1 \times 10^{-5}$  | $1.3 \times 10^{-6}$  | $1.1 \times 10^{-9}$  | $1.3 \times 10^{-5}$ | $4.1 \times 10^{-7}$  | $3.8 \times 10^{-8}$  | -3.5               | 0     | 2.4   | -2.2          | 1.2   | 3.4   |
| 0.01                                  | $1.4 \times 10^{-3}$  | $3.0 \times 10^{-5}$  | $2.3 \times 10^{-9}$  | $1.0 \times 10^{-3}$ | $2.9 \times 10^{-5}$  | $2.6 \times 10^{-6}$  | -6.5               | -2.9  | -0.5  | -6.2          | -2.9  | -0.6  |
| 0.003                                 | -                     | $6.3 \times 10^{-3}$  | $4.1 \times 10^{-9}$  | -                    | $2.1 \times 10^{-2}$  | $1.6 \times 10^{-3}$  | -11.5              | -7.9  | -5.4  | -12.3         | -8.9  | -6.7  |
| 0.001                                 | -                     | -                     | $2.2 \times 10^{-9}$  | -                    | -                     | -                     | -16.8              | -13.2 | -10.7 | -19.4         | -16.0 | -13.7 |

**Note:** Hub-to-Vsat#1: Uplink (clear air) & Downlink (with rain)  
Vsat#1-to-Hub: Uplink (with rain) & Downlink (clear Air)

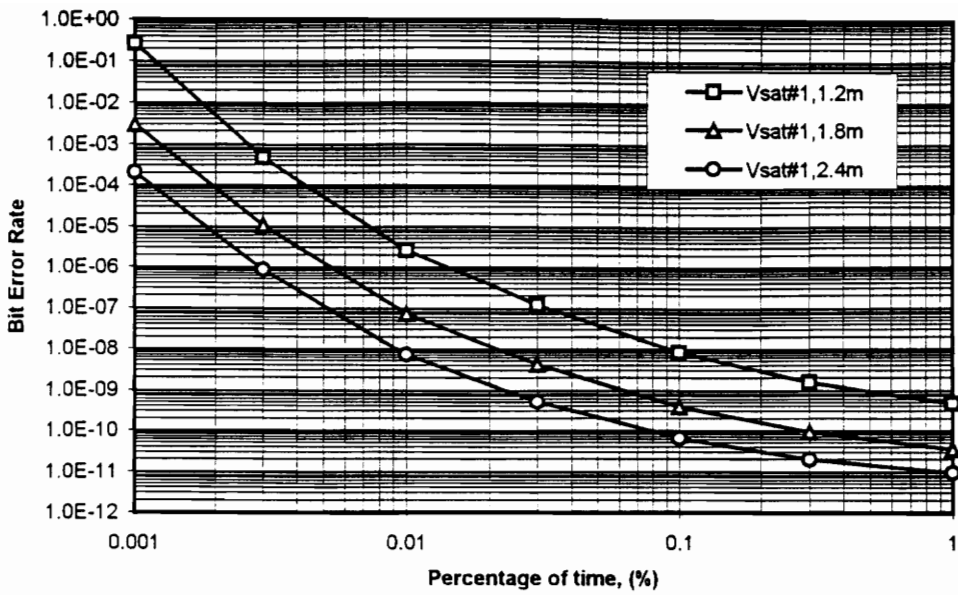

**Figure 6.1** BER Vs. Percentage of time, under rain conditions at downlink for Hub-to-VSAT#1 link, using full transponder power

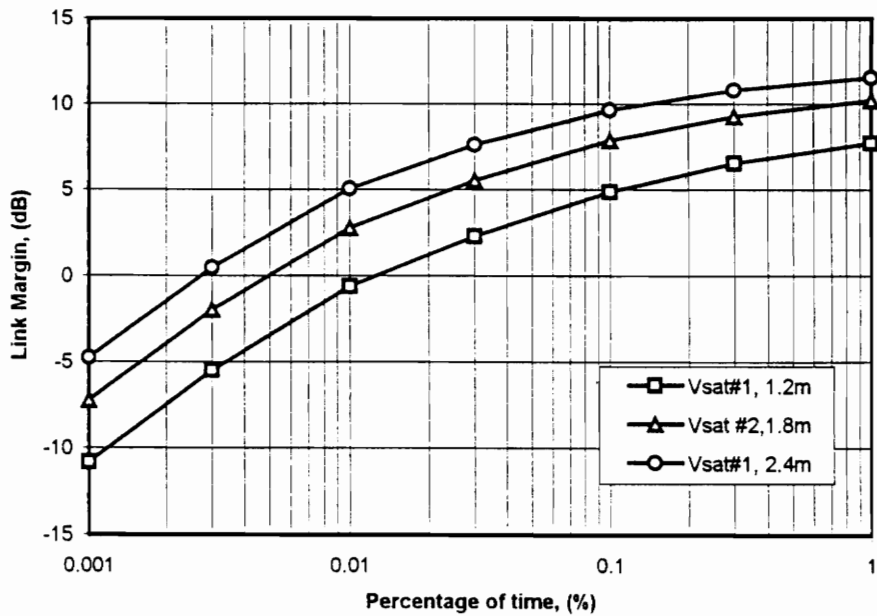

**Figure 6.2** Link Margin Vs. Percentage of time, under rain conditions at downlink for Hub-to-VSAT#1 link, using full transponder power

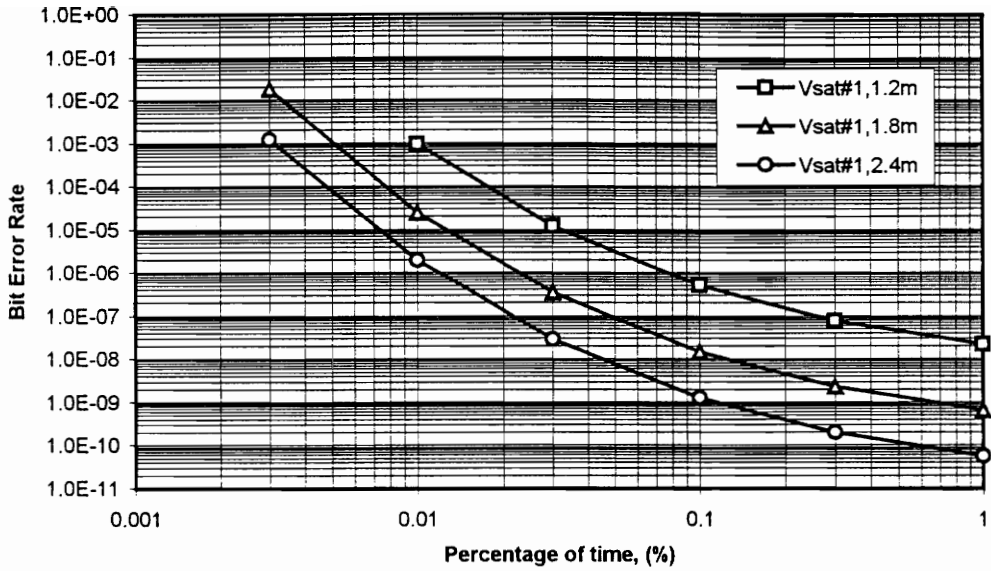

**Figure 6.3** BER Vs. Percentage of time, under rain conditions at uplink for VSAT#1-to-Hub link, using full transponder power

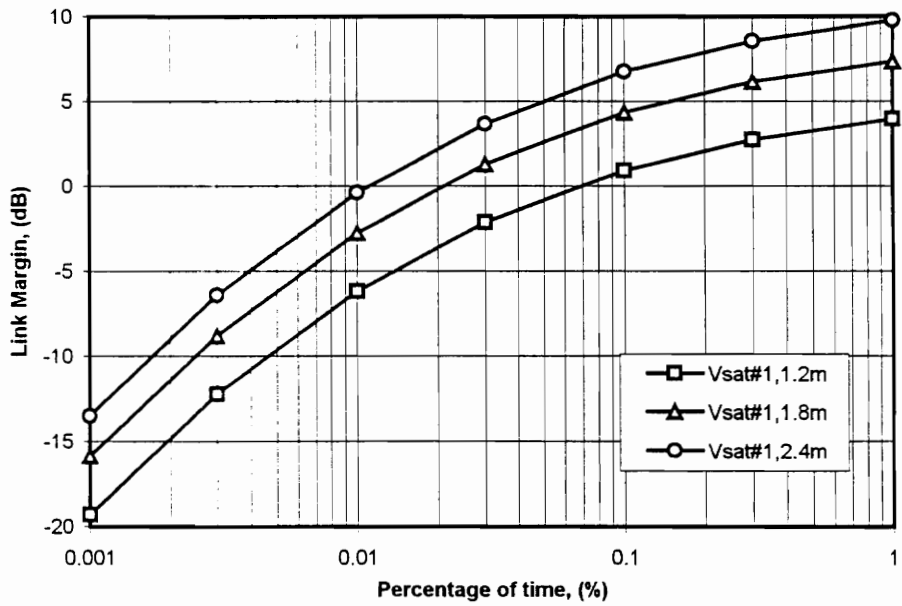

**Figure 6.4** Link Margin Vs. Percentage of time, under rain conditions at uplink for VSAT#1-to-Hub link, using full transponder power

**Table 6.3a** Summary for the THAICOM-1 educational VSAT Network

| VSAT Aperture   | Ø 1.2m           |                 | Ø 1.8m           |                 | Ø 2.4m           |                 |
|---|------------------|-----------------|------------------|-----------------|------------------|-----------------|
|   | Availability (%) | Outage (hrs/yr) | Availability (%) | Outage (hrs/yr) | Availability (%) | Outage (hrs/yr) |
| <i>Equipment Availability and Outage Time</i>                           |                  |                 |                  |                 |                  |                 |
| Transponder   |                  |                 |                  |                 |                  |                 |
| Hub (5.5m)  | 99.90            | 8.76            | 99.90            | 8.76            | 99.90            | 8.76            |
| VSAT  | 99.90            | 8.76            | 99.90            | 8.76            | 99.90            | 8.76            |
| <i>Rainfall Availability (at BER ≤ 10<sup>-7</sup>) and Outage Time</i> |                  |                 |                  |                 |                  |                 |
| Outbound to   |                  |                 |                  |                 |                  |                 |
| Ban Mae La Luang  | 96.80            | 280.32          | 99.10            | 78.84           | 99.50            | 43.80           |
| Chiang Mai  | 97.40            | 227.76          | 99.20            | 70.08           | 99.57            | 37.67           |
| Ban Chai Buri   | 96.90            | 271.56          | 99.10            | 78.84           | 99.50            | 43.80           |
| Ban Khemma Marat  | 97.60            | 210.24          | 99.20            | 70.08           | 99.59            | 35.92           |
| Ban Khlong Makhham  | 98.60            | 122.64          | 99.50            | 43.80           | 99.71            | 25.40           |
| Phuket  | 97.00            | 262.8           | 98.40            | 140.16          | 99.00            | 87.60           |
| Rangae  | 99.50            | 43.8            | 98.00            | 175.20          | 98.80            | 105.12          |
| Inbound from  |                  |                 |                  |                 |                  |                 |
| Ban Mae La Luang  | 75.00            | 2190            | 95.00            | 438.00          | 97.90            | 183.96          |
| Chiang Mai  | 75.00            | 2190            | 95.00            | 438.00          | 97.89            | 184.84          |
| Ban Chai Buri   | 72.00            | 2452.8          | 95.00            | 438.00          | 97.90            | 183.96          |
| Ban Khemma Marat  | 72.50            | 2409            | 95.00            | 438.00          | 97.90            | 183.96          |
| Ban Khlong Makhham  | 77.00            | 2014.8          | 95.40            | 402.96          | 98.00            | 175.20          |
| Phuket  | 90.00            | 876             | 93.00            | 613.20          | 97.00            | 262.80          |
| Rangae  | 69.00            | 2715.6          | 93.00            | 613.20          | 97.00            | 262.80          |

**Table 6.3b** Summary for the THAICOM-1 educational VSAT Network

| <b>VSAT Aperture</b>       |                    | <b>Ø 1.2m</b> | <b>Ø 1.8m</b> | <b>Ø 2.4m</b> |
|----------------------------|--------------------|---------------|---------------|---------------|
| <i>Clear Sky Eb/No, dB</i> |                    |               |               |               |
| Outbound to                | Ban Mae La Luang   | 20.2          | 22.3          | 23.4          |
|                            | Chiang Mai         | 7.2           | 9.3           | 10.4          |
|                            | Ban Chai Buri      | 20.9          | 22.8          | 23.7          |
|                            | Ban Khemma Marat   | 7.9           | 9.8           | 10.7          |
|                            | Ban Khlong Makhham | -5.1          | -3.2          | -2.3          |
|                            | Phuket             | -18.1         | -16.2         | -15.3         |
|                            | Rangae             | 20.2          | 22.3          | 23.4          |
|                            |                    |               |               |               |
| Inbound from               | Ban Mae La Luang   | 16.4          | 19.8          | 22.3          |
|                            | Chiang Mai         | 16.4          | 19.8          | 22.3          |
|                            | Ban Chai Buri      | 17.4          | 20.8          | 23.2          |
|                            | Ban Khemma Marat   | 17.4          | 20.8          | 23.2          |
|                            | Ban Khlong Makhham | 17.4          | 20.8          | 23.2          |
|                            | Phuket             | 17.4          | 20.8          | 23.2          |
|                            | Rangae             | 16.3          | 19.8          | 22.2          |
|                            |                    |               |               |               |

## Chapter 7 Conclusions and Recommendations

We have presented the educational VSAT network, using the THAICOM-1 satellite, that was designed for Thailand. The educational VSAT system is designed for the central university located in Bangkok and seven VSAT remote terminals throughout Thailand. The basic constraints, such as rain margin and system availability, of the system design using Ku-band have been examined. VSAT system performance has been analyzed for three different transponder utilization; full, half and quarter transponder power, and for 1.2, 1.8, and 2.4 m antennas at the VSAT remote sites and a 5.5 m antenna at the hub, with 2.048 Mbps TDM Hub-to-VSAT and 256 kbps SCPC DAMA from VSAT-to-Hub.

Examining Chapter 5 and 6, it will be observed that with the THAICOM-1 satellite and a 2 W-SSPA at the VSAT transmitter, VSAT-to-Hub links can be established by using full, half or quarter transponder power, leaving a significant margin

in up-path power for all receive antenna sizes except 1.2m. The rainfall availability can be increased by designing the link with a larger link margin, which can be achieved by using a larger receive antenna and /or a higher *EIRP* at the transmit earth station. The latter utilizes more satellite transponder power and may violate regulatory power density limits. Uplink power control can be used to compensate for uplink rain attenuation. There are other techniques to overcome rain attenuation. They include adaptive rate FEC, downlink power control, site diversity, focused satellite beams, frequency diversity, and onboard regeneration. However, these techniques may not be desirable for use with VSAT networks.

Because of the use of very small antennas and low power transmitters, a VSAT network is inherently a power-limited network. Therefore the satellite capacity usage is very inefficient. For VSAT networks to use the satellite resource (i.e. bandwidth) efficiently, a new technology such as a new digital compression technique must be designed. A key advantage of digital compression in a VSAT network is the resultant decrease in satellite transponder bandwidth and power resource required for the system, including smaller earth station and antennas.

The performance presented in this thesis has been limited to just one case of full transponder power utilization. We use about 10 MHz bandwidth for our education VSAT network leaving 44 MHz free- which could be used by another service in the future, such as a VSAT network for high-schools in Thailand. Therefore, the partial transponder

power utilization for VSAT network is also of practical significance and needs further investigation.

It has been identified that the introduction of satellite communications into the rural areas will aid development. Education is the most important thing in my belief to help the poor people in rural areas. The beneficial aspects of using satellites as a teaching tool are numerous; it can help people in the rural area have a chance to study like people in big cities, especially Bangkok. I wish that this thesis can help to overcome the slow progress of education in Thailand's rural areas someday.

## REFERENCES

- [1]. J. Everett, *VSATs: Very Small Aperture Terminals*, Peter Peregrinus Ltd.,1992 London, United Kingdom.
- [2]. D. Raychaudhuri, "Ku-band Satellite Data Networks Using Very Small Aperture Terminals-Part 2: System Design," *International Journal of Satellite Communications*, March 1987, pp. 265-278.
- [3]. D. Chakraborty, "Constraints in Ku-band Continental Satellite Network Design," *IEEE Communications Magazine*, August 1986, pp. 33-43.
- [4]. D. Chakraborty, "VSAT Communications Networks- An Overview," *IEEE Communications Magazine*, May 1988, pp. 10-24.
- [5]. S. M. Hower, "African Distance Learning Via Satellite," *Tenth International Conference on Digital Satellite Communications*,15-19 May 1995, The Metropole Hotel, Brighton, UK, Volume No.2, pp.532-538.
- [6]. J. Gerardo Muros, "Two Singular Experiences Performed by Telefonica of Spain, Using Hispasat Satellite Communication. Tele-Education and Early Fire-Detection," *Tenth International Conference on Digital Satellite Communications*, 15-19 May 1995, The Metropole Hotel, Brighton, UK, Volume No.2, pp. 627-630.

- [7] Y. Nomachi, K. Ishii and M.Domae, "An Educational Network Using a VSAT System," *Mitsubishi electric advance*, March 1992, pp. 24-27.
- [8] K. Mcfarlane, B. M. Read, "Conversat '88: Enhanced Delivery of Tele-Education Using VSAT Technology," *Proc. Olympus Utilization Conference*, Vienna, 12-14 April 1989, pp. 321-326.
- [9] Shinawatra Satellite Public Company Limited, "*Technical Memorandum of Space Segment Capacity in the Thaicom-1 Satellite*," March 17, 1994.
- [10] G. K.C. Pardoe, "Design and operational considerations of educational satellite systems," *Proceedings of the Royal Society of London*, Volume No. 345, pp. 477-491(1975).
- [11] Y. Pal, "Some experiences in preparing of a satellite television experiment for rural India," *Proceedings of the Royal Society of London*, Volume No. 345, pp. 437-447 (1975).
- [12] R. L. Freeman, *Reference Manual for Telecommunications Engineering*, John Wiley & Sons, New York, 1994.
- [13] L. Sam, "Performance comparison of MPEG-1 and MPEG-2 video compression standards," *Proceedings of the 1996 41<sup>st</sup> IEEE Computer Society International Conference*, Piscataway, NJ, pp. 199-202
- [14] D.W.E. Rees, *Satellite Communications-The First Quarter Century of Service*, John Wiley & Sons, New York, 1990.
- [15] M. Maggenti, T.T. HA and T. Pratt "VSAT Networks-An Overview," *International Journal of Satellite Communications*, October 1987, pp. 219-225.
- [16] X.T. Vuong, F.S. Zimmermann, T.M. Shimabukuro, "Performance Analysis of Ku-band VSAT Networks," *IEEE Communications Magazine*, May1988, pp. 25-32.
- [17] The National Identity Office of the Prime Minister, "*THAILAND in the 90s*," Victory Power Point Corp.,Ltd., 1991.
- [18] Armed Forces Information Office, "*Everything Begins in The Countryside*", The War Veterans Organization of Thailand Under Royal Patronage, Bangkok, 1989.
- [19] M. Long, "*The 1993/1994 World Satellite Annual*," Mark Long Enterprises, Inc.,

Florida, USA, 1992.

- [20] M. A. House, "Use of telecommunications to meet health needs of rural, remote and isolated communities," *Proceedings of SPIE- The International Society for Optical Engineering*, Volume No.1355,1990, pp. 2-9.
- [21] H. Chasia, "Satellites and Developing Countries," *IEEE Communications Magazine*, September 1995, pp. 110-112.
- [22] T. Pratt and C. W. Bostain, *Satellite Communications*, John Wiley & Sons, NewYork, 1986.
- [23] K. G. Johannsen and C. Cuevas, "Ku- Vs. C-Band and Digital Vs. Analogue Television Transmission in a Tropical Climate," *International Journal of Satellite Communications*, May 1993, pp.119-143.
- [24] M. Yamada, Y. Karasawa and M. Yasumaga, "An improved prediction method for attenuation in satellite communications operating at 10-20 GHz," *Radio Science*, 22, (6), 1053-1062 (1987).
- [25] K. A. Hughes, "CCIR Data for Slant-path Propagation in Tropical Regions: A Critical Review," *International Journal of Satellite Communications*, May-June 1990, pp.127-139.
- [26] G. O. Ajayi, "Some Aspects of Tropical Rainfall and their Effect on Microwave Propagation," *International Journal of Satellite Communications*, May-June 1990, pp.163-172.
- [27] R. K. Crane, "Modelling Attenuation by Rain in Tropical Regions," *International Journal of Satellite Communications*, May-June 1990, pp.197-210.
- [28] F. Haidara, T. Pratt and C. W. Bostian, "Preliminary Plans for a Propagation Experiment in Mali," *International Journal of Satellite Communications*, May-June 1990, pp. 269-275.
- [29] G. Maral, M. Bousquet, *Satellite Communications Systems*, John Wiley & Sons, England, 1993.

## Appendix A. THAICOM Technical Description

### THAICOM-1

#### Thaicom-1 Spacecraft Characteristics

|                            |   |
|----------------------------|---|
| Manufacturer               | Hughes Aircraft Company   |
| Satellite bus              | HS 376  |
| Spacecraft mass            |   |
| at launch                  | 1080 kg.  |
| at beginning of life (BOL) | 627 kg.   |
| Body dimensions            |   |
| diameter                   | 2.16 m.   |
| height                     | 6.6 m.  |
| solar array drum extended  | 2.6 m. stowed   |
| Lifetime                   |   |
| design lifetime            | 15 years  |
| minimum lifetime           | 13.5 years  |
| Spacecraft stabilization   | Dual Spin.  |
| Orbital position           | 120° E  |
| Power system               | -Silicon solar cell<br>-Nickel hydrogen battery<br>for eclipses |
| Antenna                    | dual aperture   |
| Transponders               | 10 C-Band (36 MHz) and<br>2 Ku-Band (54 MHz)                    |
| Launch vehicle             | Ariane 4  |
| Launch date                | December 18, 1993 (GMT)   |

SHINAWATRA SATELLITE PROPRIETARY. INFORMATION SUBJECT TO CHANGE. JUNE 1995

# THAICOM-1

## C-Band Communications Subsystem Characteristics

|                            |  |
|----------------------------|--|
| Number of Transponders     | 10   |
| Back-up Transponders       | 2  |
| Bandwidth                  | 36 MHz   |
| Receive side (Up-link)     | 5,925 - 6,425 MHz<br>(Horizontal)                    |
| Transmit side (Down-link)  | 3,700 - 4,200 MHz<br>(Vertical)                      |
| Maximum Flux Density (MFD) | -(80+G/T) dBW/m <sup>2</sup><br>at min. gain setting |
| Gain Adjustment            | 2 dB steps over<br>the range of 14 dB                |
| Receiver redundancy        | 2 for 1  |

## C-Band Frequency and Polarization Plan

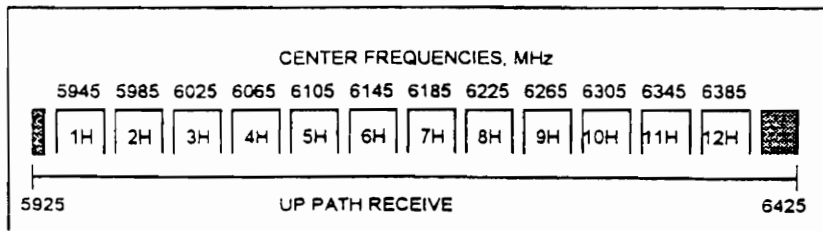
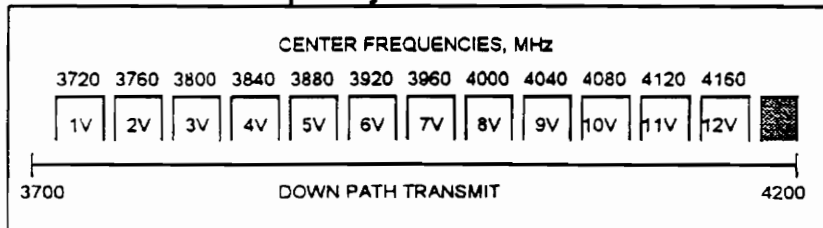

V = VERTICAL POLARIZATION, H = HORIZONTAL POLARIZATION

SHINAWATRA SATELLITE PROPRIETARY. INFORMATION SUBJECT TO CHANGE, JUNE 1985

# THAICOM-1

## C-Band Coverage EIRP Contours (dBW)

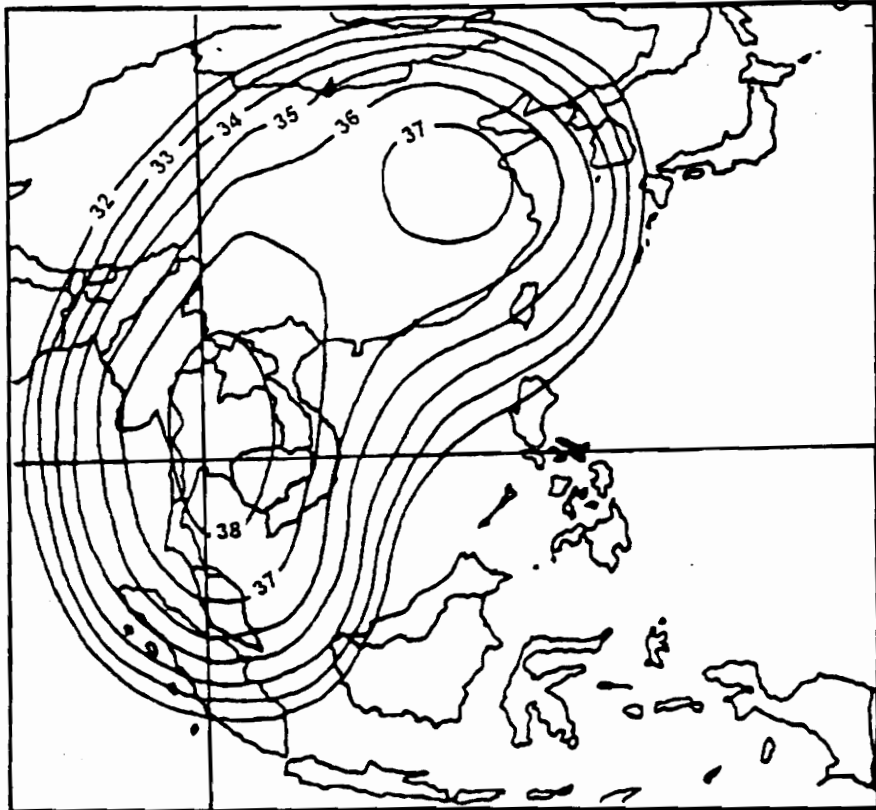

SHINAWATRA SATELLITE PROPRIETARY. INFORMATION SUBJECT TO CHANGE. JUNE 1995

# THAICOM-1

## C-Band Coverage G/T Contours (dB/K)

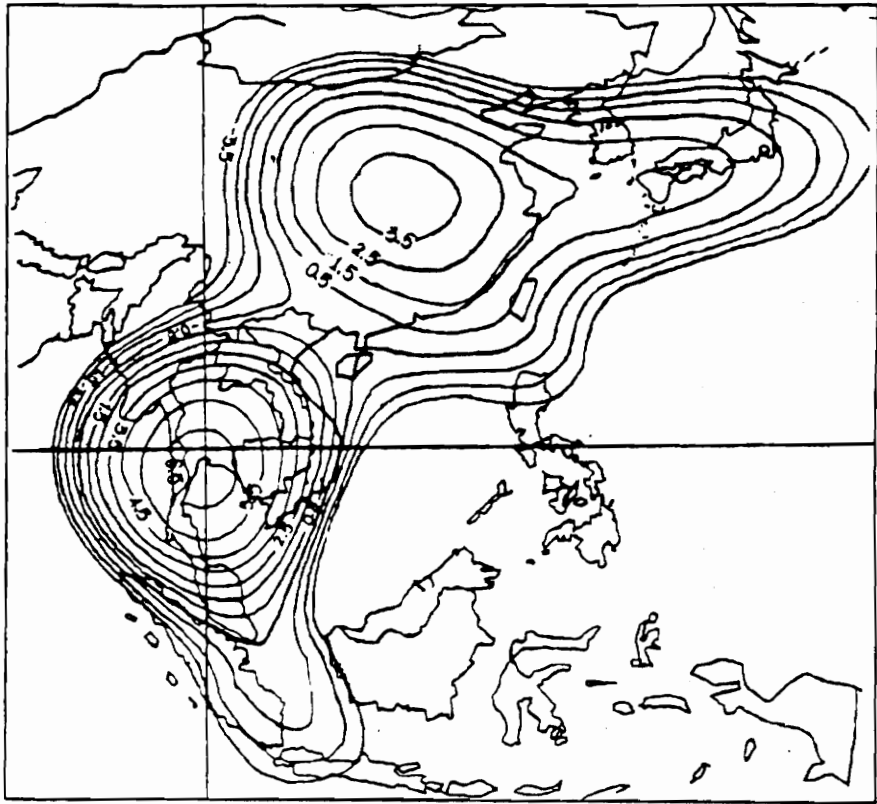

SHINAWATRA SATELLITE PROPRIETARY. INFORMATION SUBJECT TO CHANGE. JUNE 1995

# THAICOM-1

## Ku-Band Coverage EIRP Contours (dBW)

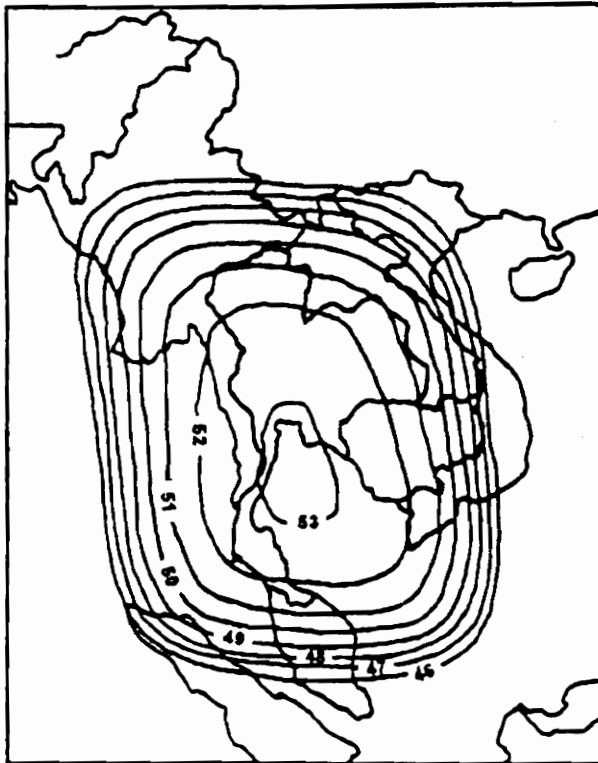

SHINAWATRA SATELLITE PROPRIETARY. INFORMATION SUBJECT TO CHANGE. JUNE 1995

# THAICOM-1

## Ku-Band Coverage G/T Contours (dB/K)

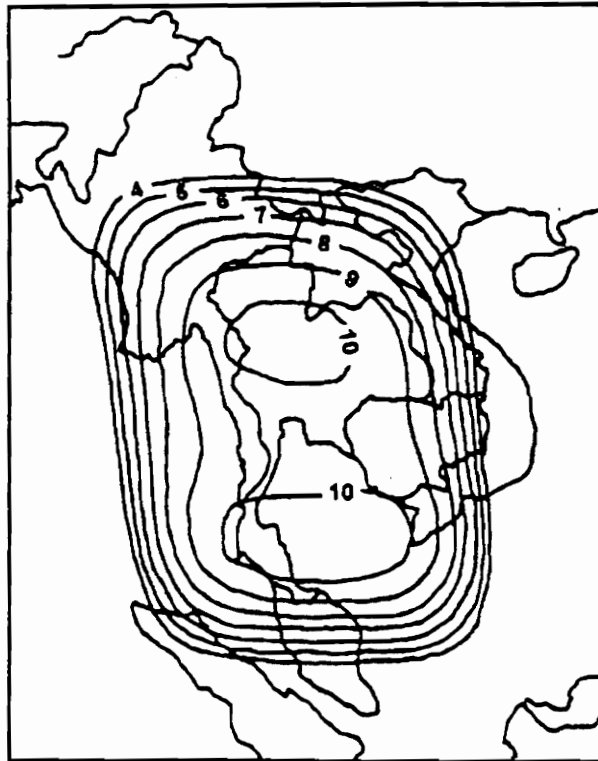

SHINAWATRA SATELLITE PROPRIETARY. INFORMATION SUBJECT TO CHANGE, JUNE 1995

# THAICOM-2

## Thaicom-2 Spacecraft Characteristics

|                             |   |
|-----------------------------|---|
| Manufacturer                | Hughes Aircraft Company   |
| Satellite bus               | HS 376  |
| Spacecraft mass             |   |
| at launch                   | 1080 kg.  |
| at beginning of life (BOL)  | 627 kg.   |
| Body dimensions             |   |
| diameter                    | 2.16 m.   |
| height                      | 6.6 m.  |
| ☛ solar array drum extended | 2.6 m. stowed   |
| Lifetime                    |   |
| design lifetime             | 15 years  |
| minimum lifetime            | 13.5 years  |
| Spacecraft stabilization    | Dual Spin   |
| Orbital position            | 78.5° E   |
| Power system                | -Silicon solar cell<br>-Nickel hydrogen battery<br>for eclipses |
| Antenna                     | dual aperture   |
| Transponders                | 10 C-Band (36 MHz) and<br>2 Ku-Band (54 MHz)                    |
| Launch vehicle              | Ariane 4  |
| Launch date                 | October 1994  |

Shinawatra Satellite Public Company Limited, July 1994

# THAICOM-2

## THAICOM-2 (78.5 °E) C-Band Coverage EIRP Contours (dBW) in Asia

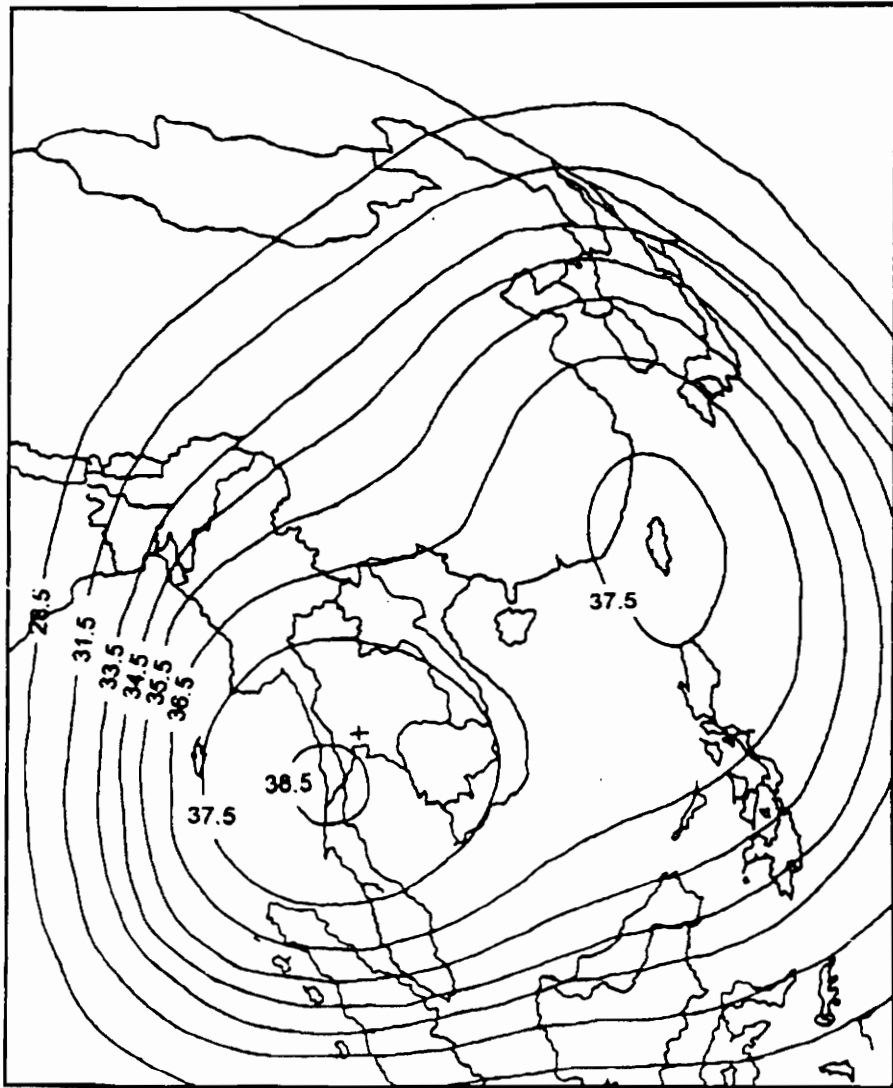

Shinawatra Satellite Public Company Limited, July 1994

# THAICOM-2

## THAICOM-2 (78.5° E) C-Band Coverage G/T Contours (dB/K) in Asia

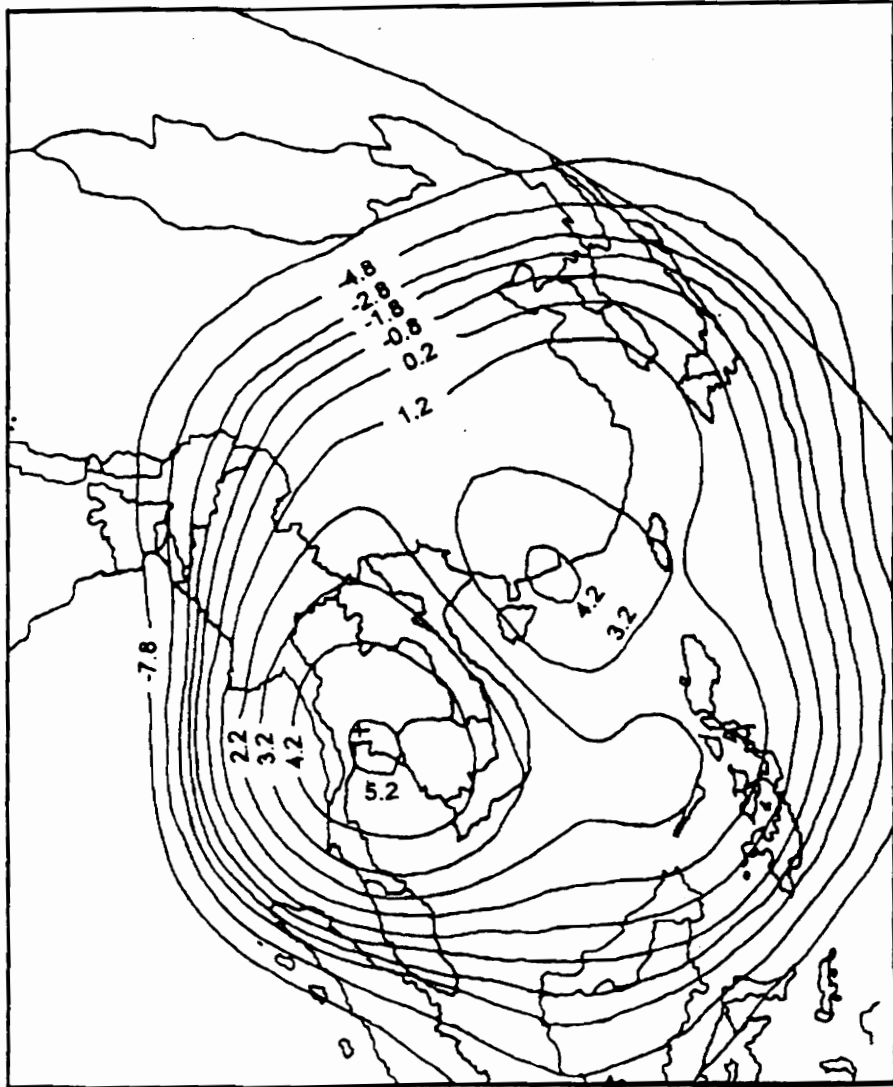

Shinewatra Satellite Public Company Limited, July 1994

# THAICOM - 2

## Coverage Footprints

**Ku-Band Coverage EIRP Contours (dBW)**

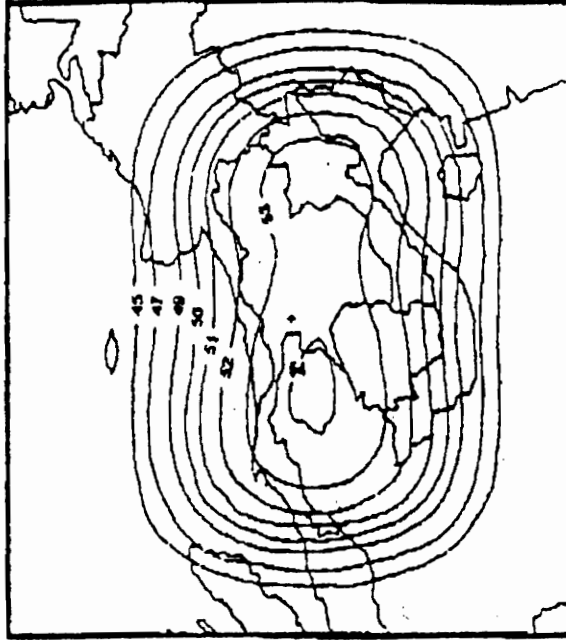

**Ku-Band Coverage G/T Contours (dB/K)**

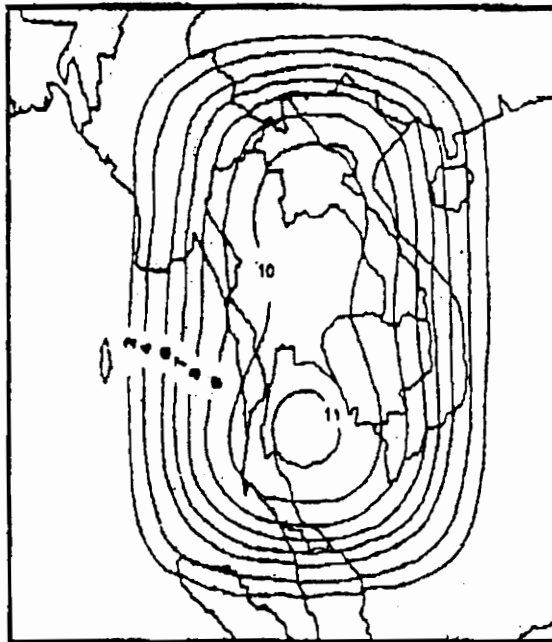

# THAICOM-3

## C-BAND REGIONAL BEAM (SUBCONTINENT)

### *C-Band Communications Subsystem Characteristics*

|                            |  |
|----------------------------|--|
| Number of Transponders     | 18   |
| Bandwidth                  | 36 MHz   |
| Receive side (Up-link)     | 5,925 - 6,725 MHz<br>(Horizontal)                    |
| Transmit side (Down-link)  | 3,400 - 4,200 MHz<br>(Vertical)                      |
| Maximum Flux Density (MFD) | -(80+G/T) dBW/m <sup>2</sup><br>at min. gain setting |
| Gain Adjustment            | 2 dB steps over<br>the range of 14 dB                |
| Redundancy                 | 24 : 18  |

### *C-Band Frequency and Polarization Plan*

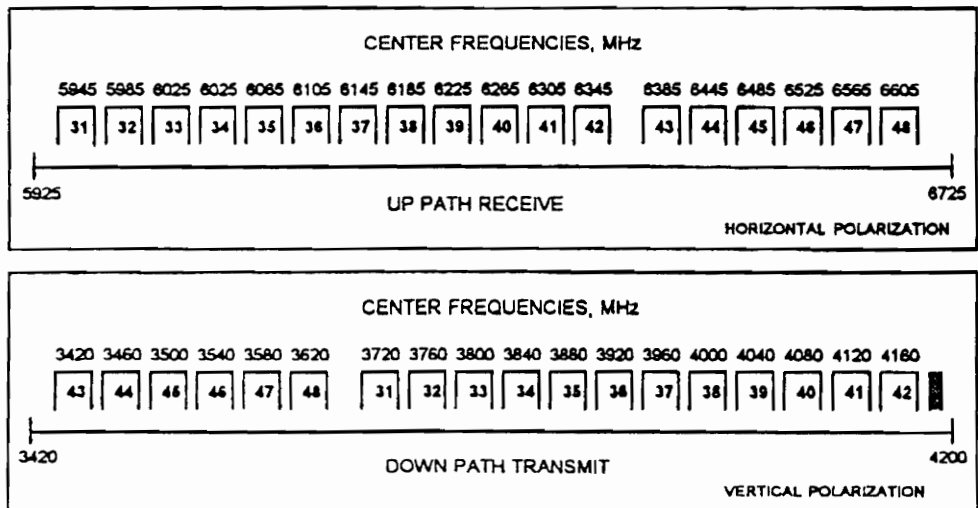

SHINAWATRA SATELLITE PROPRIETARY. INFORMATION SUBJECT TO CHANGE, JUNE 1995

# THAICOM-3

## C-BAND REGIONAL BEAM (SUBCONTINENT)

*C-Band Coverage EIRP Contours (dBW)*

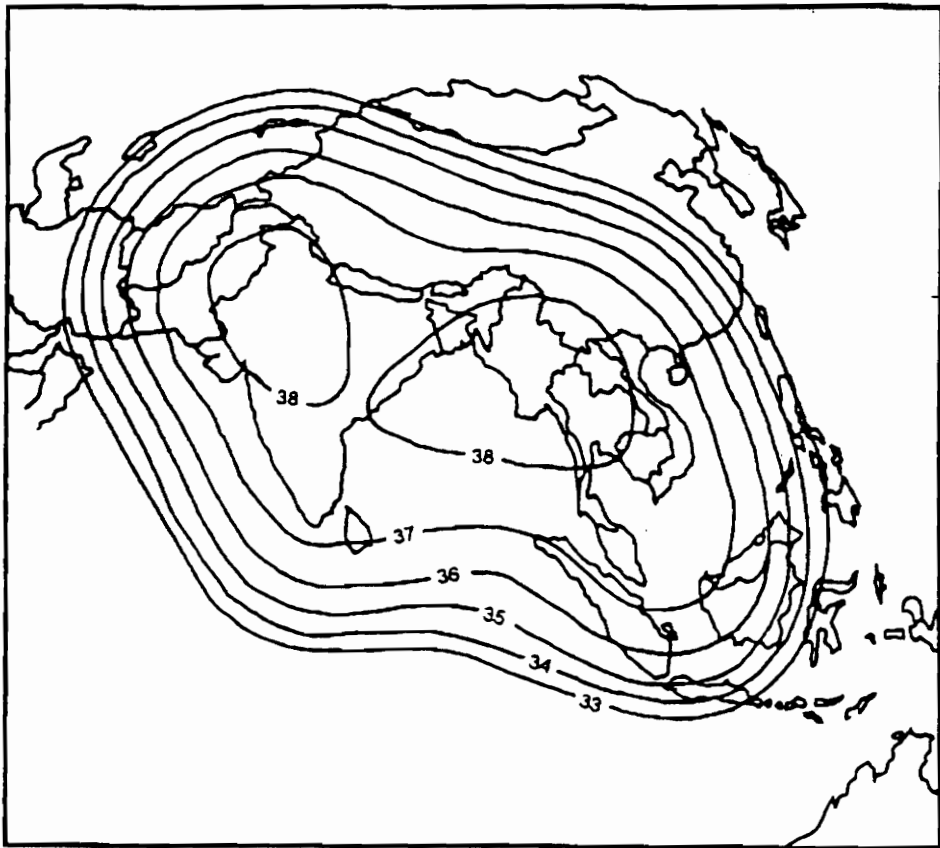

SHINAWATRA SATELLITE PROPRIETARY. INFORMATION SUBJECT TO CHANGE, JUNE 1995

# THAICOM-3

## C-BAND REGIONAL BEAM (SUBCONTINENT)

*C-Band Coverage G/T Contours (dB/K)*

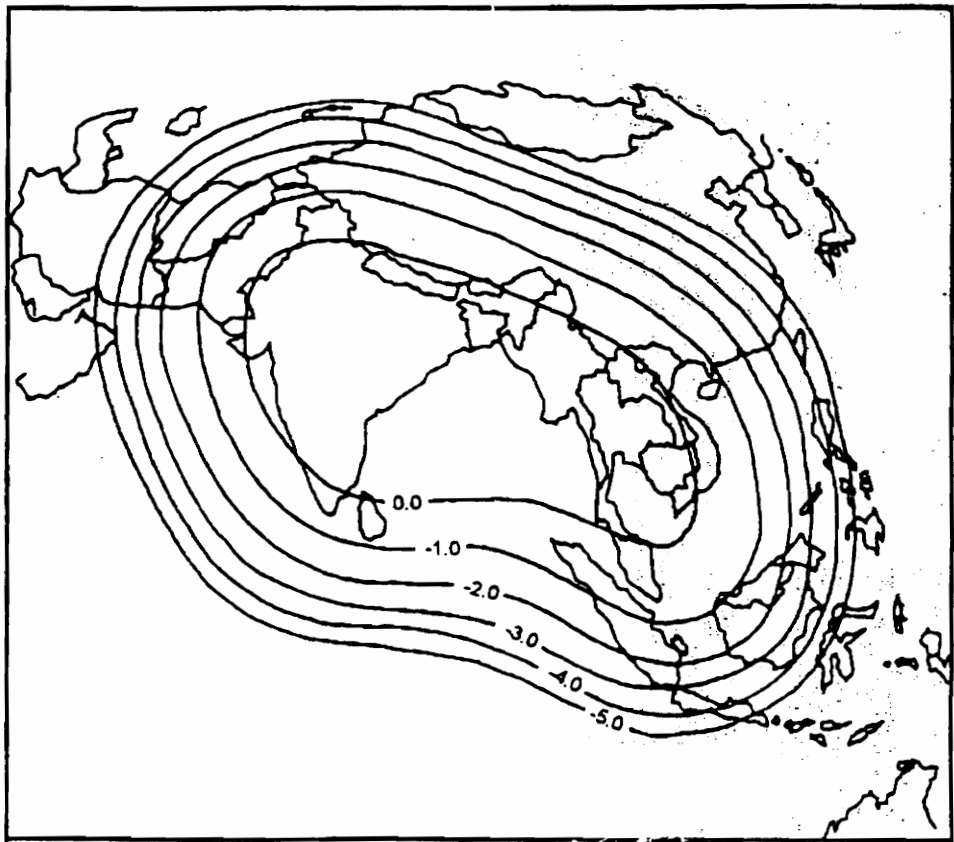

SHINAWATRA SATELLITE PROPRIETARY. INFORMATION SUBJECT TO CHANGE. JUNE 1995

# THAICOM-3

## C-BAND GLOBAL BEAM (CONTINENTALS)

### *C-Band Communications Subsystem Characteristics*

|                            |  |
|----------------------------|--|
| Number of Transponders     | 6  |
| Bandwidth                  | 36 MHz   |
| Receive side (Up-link)     | 6,425 - 6,725 MHz<br>(Vertical)                      |
| Transmit side (Down-link)  | 3,400 - 3,700 MHz<br>(Horizontal)                    |
| Maximum Flux Density (MFD) | -(80+G/T) dBW/m <sup>2</sup><br>at min. gain setting |
| Gain Adjustment            | 2 dB steps over<br>the range of 14 dB                |
| Redundancy                 | 9 : 6  |

### *C-Band Frequency and Polarization Plan*

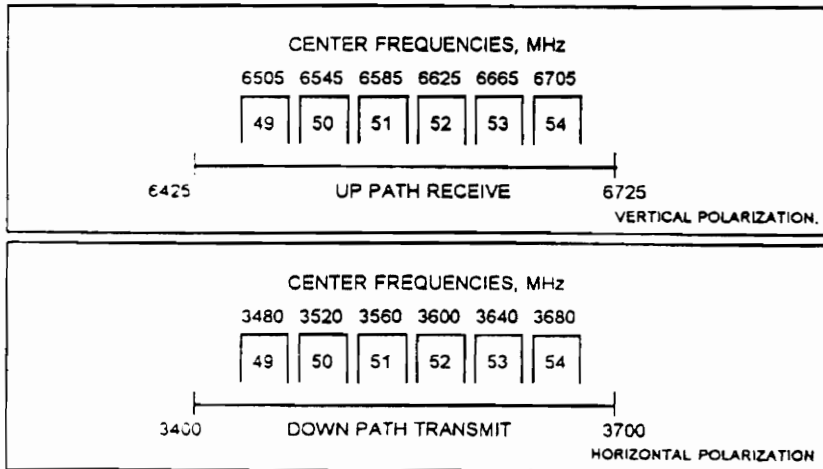

SHINAWATRA SATELLITE PROPRIETARY. INFORMATION SUBJECT TO CHANGE, JUNE 1995

# THAICOM-3

## C-BAND GLOBAL BEAM (CONTINENTALS)

*C-Band Coverage EIRP Contours (dBW)*

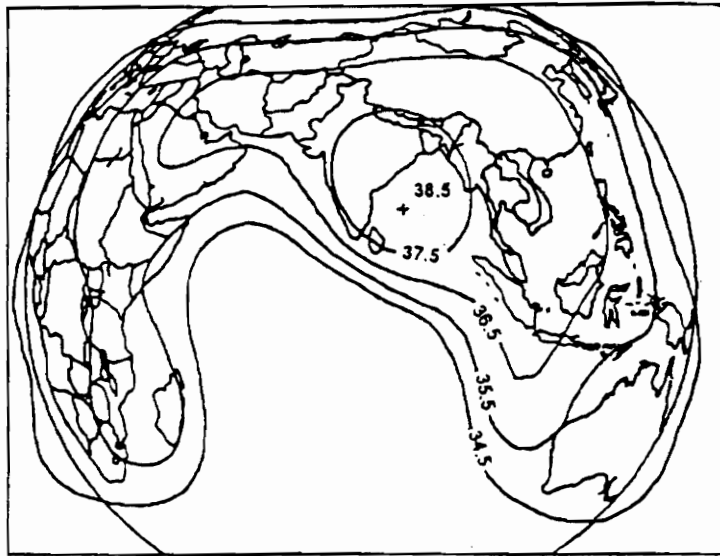

SHINAWATRA SATELLITE PROPRIETARY. INFORMATION SUBJECT TO CHANGE. JUNE 1995

# THAICOM-3

## C-BAND GLOBAL BEAM (CONTINENTALS)

*C-Band Coverage G/T Contours (dB/K)*

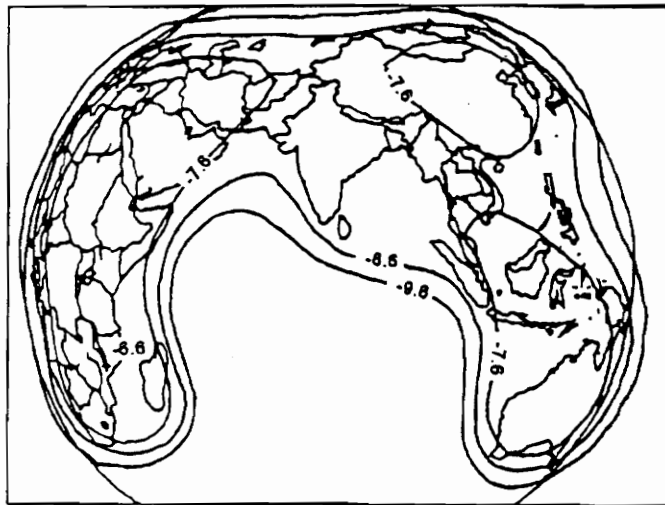

SHINAWATRA SATELLITE PROPRIETARY. INFORMATION SUBJECT TO CHANGE. JUNE 1995

# THAICOM-3

## KU-BAND SPOT BEAM

### *Ku-Band Communications Subsystem Characteristics*

|                               |  |
|-------------------------------|--|
| Number of Transponders        | 11   |
| Bandwidth                     | 2 x 54 MHz<br>9 x 36 MHz                             |
| Receive side (Up-link)        | 14,000 - 14,500 MHz<br>(Horizontal)                  |
| Transmit side (Down-link)     | 12,200 - 12,750 MHz<br>(Horizontal)                  |
| Saturation Flux Density (SFD) | -(72+G/T) dBW/m <sup>2</sup><br>at min. gain setting |
| Gain Adjustment               | 2 dB steps over<br>the range of 14 dB                |

### *Ku-Band Frequency and Polarization Plan*

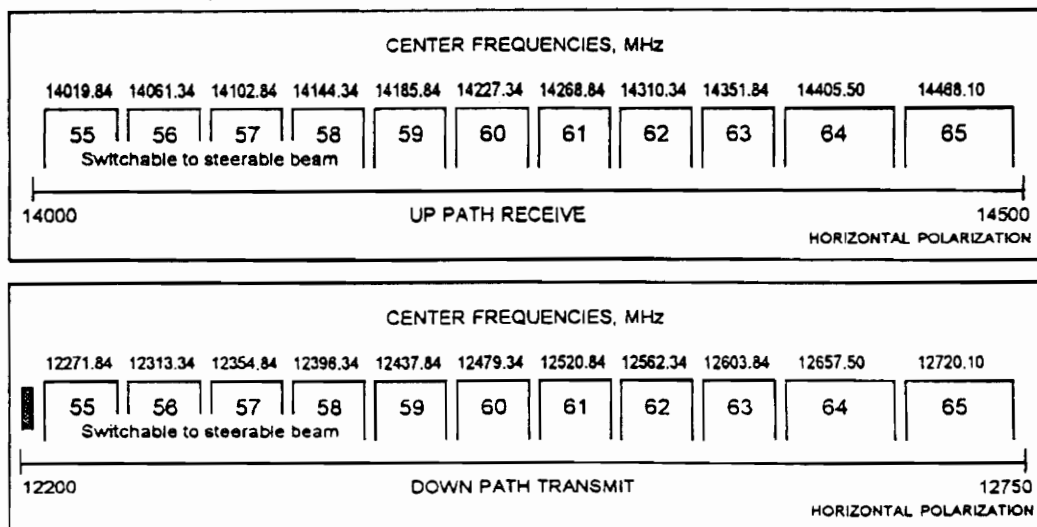

SHINAWATRA SATELLITE PROPRIETARY. INFORMATION SUBJECT TO CHANGE, JUNE 1995

# THAICOM-3

## KU-BAND SPOT BEAM

*Ku-Band EIRP Contours (dBW)*

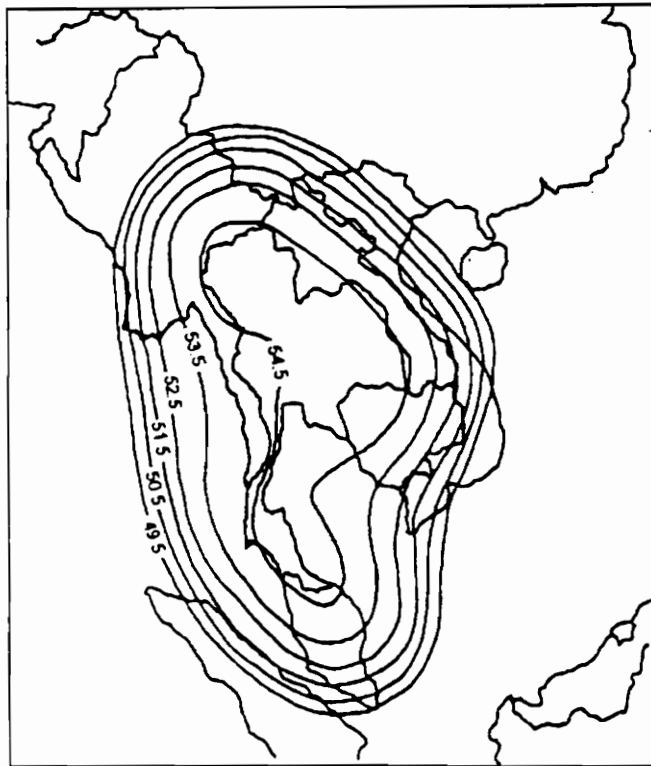

SHINAWATRA SATELLITE PROPRIETARY INFORMATION SUBJECT TO CHANGE, JUNE 1995

# THAICOM-3

## KU-BAND SPOT BEAM

*Ku-Band G/T Contours (dB/K)*

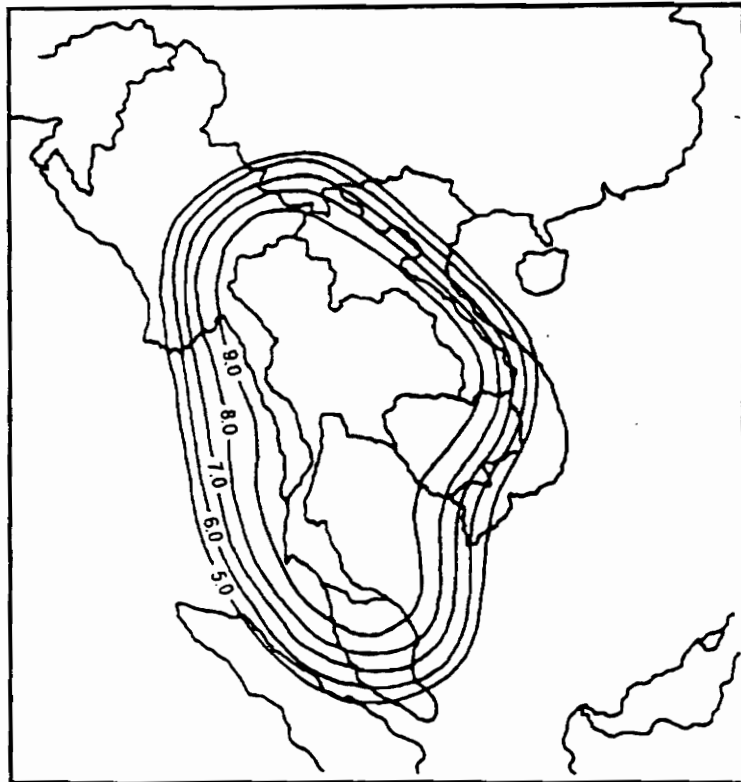

SHINAWATRA SATELLITE PROPRIETARY. INFORMATION SUBJECT TO CHANGE. JUNE 1995

# THAICOM-3

## KU-BAND STEERABLE BEAM

### *Ku-Band Communications Subsystem Characteristics*

|                               |  |
|-------------------------------|--|
| Number of Transponders        | 7  |
| Bandwidth                     | 36 MHz   |
| Receive side (Up-link)        | 14,000 - 14,500 MHz<br>(Vertical)                    |
| Transmit side (Down-link)     | 12,200 - 12,750 MHz<br>(Vertical)                    |
| Saturation Flux Density (SFD) | -(72+G/T) dBW/m <sup>2</sup><br>at min. gain setting |
| Gain Adjustment               | 2 dB steps over<br>the range of 14 dB                |

### *Ku-Band Frequency and Polarization Plan*

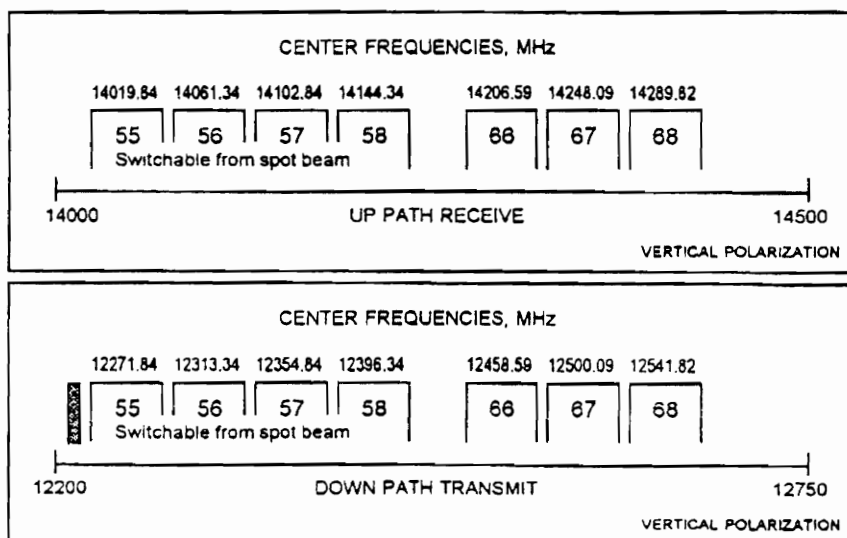

SHINAWATRA SATELLITE PROPRIETARY. INFORMATION SUBJECT TO CHANGE. JUNE 1995

# THAICOM-3

## KU-BAND STEERABLE BEAM

Predicted Contours for CHINA Coverage

*Ku-Band EIRP Contours (dBW)*

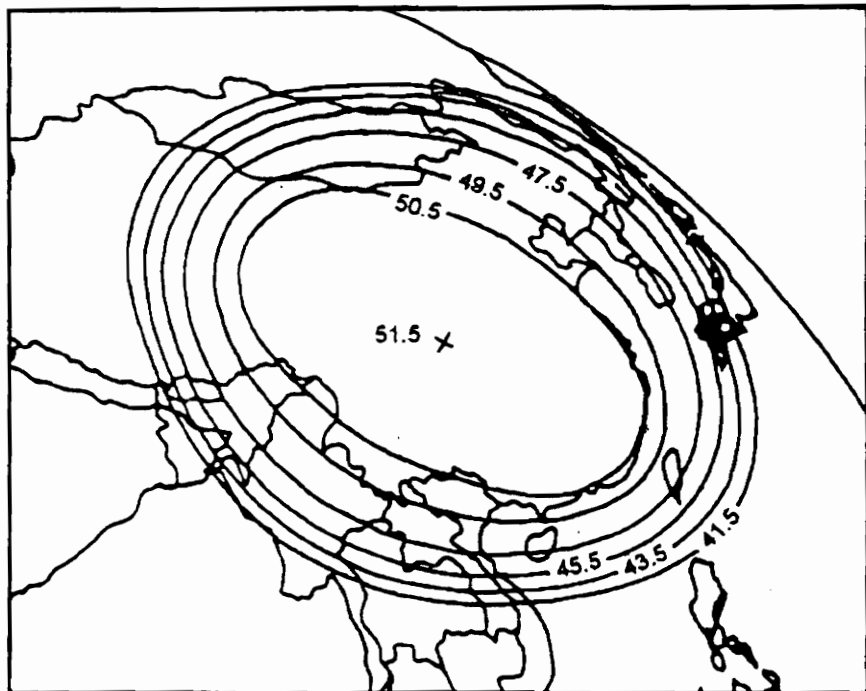

SHINAWATRA SATELLITE PROPRIETARY INFORMATION SUBJECT TO CHANGE. JUNE 1995

# THAICOM-3

## KU-BAND STEERABLE BEAM

Predicted Contours for CHINA Coverage

*Ku-Band G/T Contours (dB/K)*

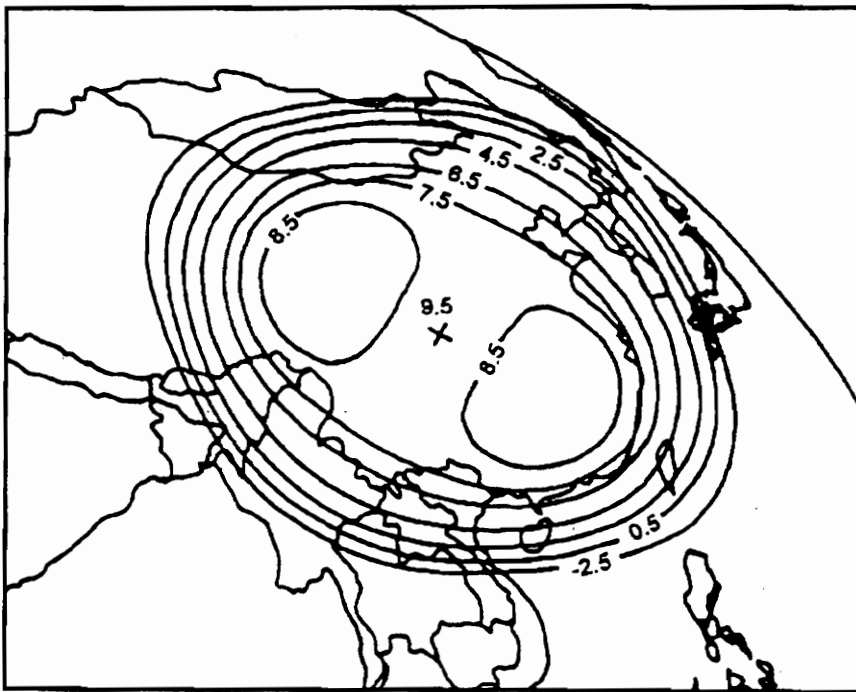

SHINAWATRA SATELLITE PROPRIETARY. INFORMATION SUBJECT TO CHANGE. JUNE 1995

# THAICOM-3

## KU-BAND STEERABLE BEAM

### *Ku-Band Communications Subsystem Characteristics*

|                               |  |
|-------------------------------|--|
| Number of Transponders        | 7  |
| Bandwidth                     | 36 MHz   |
| Receive side (Up-link)        | 14,000 - 14,500 MHz<br>(Vertical)                    |
| Transmit side (Down-link)     | 12,200 - 12,750 MHz<br>(Vertical)                    |
| Saturation Flux Density (SFD) | -(72+G/T) dBW/m <sup>2</sup><br>at min. gain setting |
| Gain Adjustment               | 2 dB steps over<br>the range of 14 dB                |

### *Ku-Band Frequency and Polarization Plan*

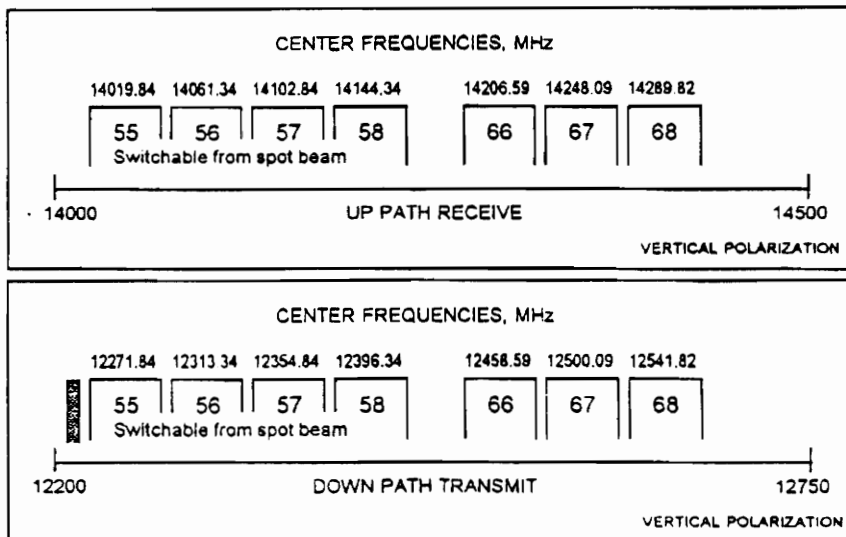

SHINAWATRA SATELLITE PROPRIETARY. INFORMATION SUBJECT TO CHANGE. JUNE 1995

# THAICOM-3

## KU-BAND STEERABLE BEAM

Predicted Contours for INDIA Coverage

*Ku-Band EIRP Contours (dBW)*

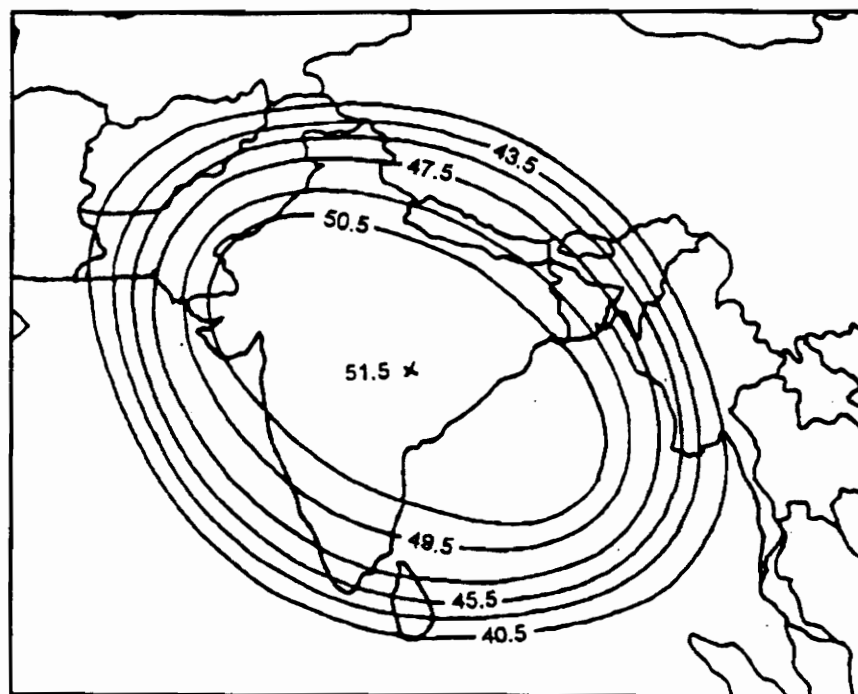

SHINAWATRA SATELLITE PROPRIETARY. INFORMATION SUBJECT TO CHANGE, JUNE 1995

# THAICOM-3

## KU-BAND STEERABLE BEAM

Predicted Contours for INDIA Coverage

*Ku-Band G/T Contours (dB/K)*

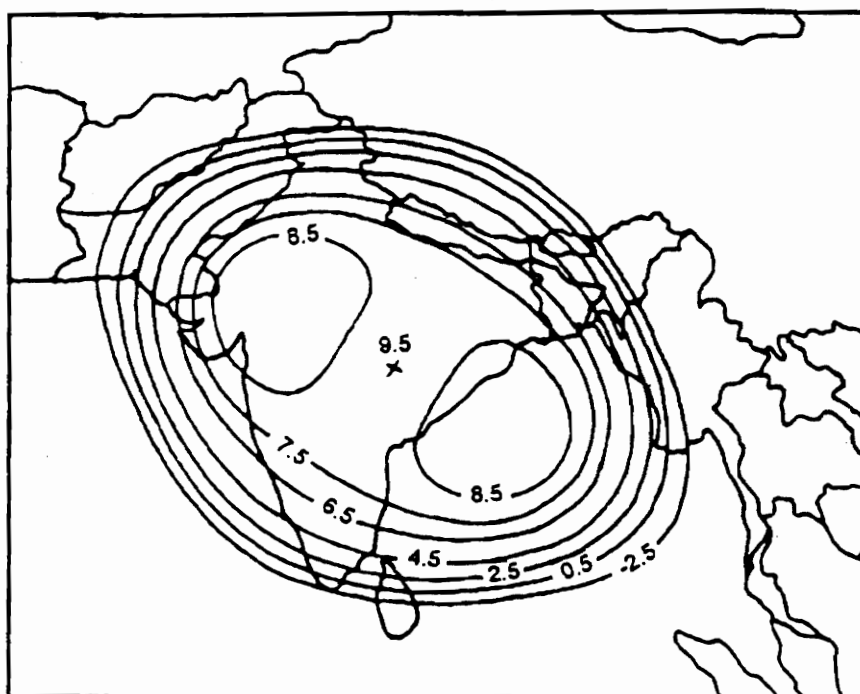

SHINAWATRA SATELLITE PROPRIETARY. INFORMATION SUBJECT TO CHANGE. JUNE 1995

## **Appendix B. Standards**

### **B.1 H.261**

Recommendation H.261 was ratified by the CCITT for audio-visual transmission of videotelephony and videoconference signals at bit rates between 64kbps and 2 Mbps in 1990. This standard provided both lower transmission costs and a unified standard, allowing global compatibility which is important for the expansion of audio-visual services. However, H.261 was developed for use over fixed links and is not well suited for use over channels with poor error performance.

The H.261 standard specifies a real-time encoding-decoding system with a delay less than 50 ms. The algorithm is capable of running over a set of transmission rates of  $p \times 64$  kbps ( $p= 1,2,\dots,30$ ). The format of the input is based on the Common Intermediate Format (CIF) which is 360 pixels by 288 lines for luminance and 180 pixels

by 144 lines for chrominance. The frames are not interlaced and the input rate is 29.97 frames/second for NTSC-compatible systems. For videophone applications where low bit rates are required, another format,  $\frac{1}{4}$  CIF (QCIF) which is 180 pixels by 144 lines for the luminance and 90 pixels by 72 lines for chrominance signals, has also been defined in the standard.

## **B.2 MPEG-1**

MPEG - which stands for Moving Picture Experts Group was started in 1988 for CD-ROM applications at a bit-rate below 1.5 Mbps. MPEG-1 was originally developed for storage of full-motion video. The recommended input picture size for the MPEG standard is  $360 \times 240$  pixels for luminance and  $180 \times 120$  for chrominance, and the frame rate is 29.97 frames/second for NTSC-compatible systems (these parameters can vary in the standard). The major difference between the two is that MPEG-1 allows bi-directional motion-compensation.

## **B.3 MPEG-2**

MPEG-2 was enacted for broader and higher bit-rate applications including broadcasting, consumer electronics, and telecommunications. The MPEG-1 standard can provide a broad range of bit-rates due to its parameterization approach, although the standard was originally aimed at below 1.5 Mbps for CD-ROM applications. However, its quality and flexibility are considered not ideal enough for the above-named

applications at higher bit rate. Thus, the MPEG-2 standard was put together. Some of MPEG-2's features include interlaced-video manipulation, scalability, compatibility, error resilience, and "hooks and options" for very high resolution video coding. It is believed that the NTSC video quality can be achieved with a bit rate of 4-6 Mbps by using MPEG-2

## **B.4 MPEG-4**

MPEG-4 is expected to be rectified in 1998. MPEG-4 target applications which include real-time audio-visual communications, multimedia, and remote sensing. It has also identified categories of requirements, including input material, quality, video format, bit rate, delay, complexity, error resilience, security, interactive operation, network interoperability, annotation of other data, and extensibility. It is very different from MPEG-1 and 2 in that the coding technology behind it is yet to be selected.

## **Appendix C. Tables of Link Budgets and Figures of Performance for THAICOM-1 Educational VSAT Network**

**Table C.1** Link Analysis: Bangkok Hub to Chiang Mai (VSAT#2) Link.

Hub transmits one coded 4.512 Mbps TDM carrier (outbound) and receive 8 coded 564 kbps SCPC DAMA carriers (inbound). Use Full Transponder of THAICOM-1, in Clear Air.

|   | Hub-to-VSAT#2          |                        |                        | VSAT#2-to-Hub         |                        |                       |
|---|------------------------|------------------------|------------------------|-----------------------|------------------------|-----------------------|
|   | Ø 1.2m                 | Ø 1.8m                 | Ø 2.4m                 | Ø 1.2m                | Ø 1.8m                 | Ø 2.4m                |
| <i>Uplink (14GHz)</i>   |                        |                        |                        |                       |                        |                       |
| 1. Earth Station <i>EIRP</i> , (dBW)  |                        | 63                     |                        | 45.7                  | 49.2                   | 51.7                  |
| 2. Uplink Path Loss, (dB)   |                        | 207                    |                        |                       | 207                    |                       |
| 3. Atmospheric Loss (Clear Sky), (dB)   |                        | 0.2                    |                        |                       | 0.2                    |                       |
| 4. Antenna Pointing Loss, (dB)  |                        | 0.5                    |                        |                       | 0.2                    |                       |
| 5. Satellite <i>G/T</i> , (dB/K)  |                        | 9.4                    |                        |                       | 9.2                    |                       |
| 6. Uplink <i>C/N<sub>o</sub></i> , (dB)   |                        | 93.3                   |                        | 76.1                  | 79.6                   | 82.1                  |
| <i>Downlink (12GHz)</i>   |                        |                        |                        |                       |                        |                       |
| 7. Transponder <i>EIRP</i> /carrier with 3 dB back-off, (dBW)                         |                        | 48.6                   |                        |                       | 41.5                   |                       |
| 8. Downlink Path Loss, (dB)   |                        | 205.5                  |                        |                       | 205.5                  |                       |
| 9. Atmospheric Loss (Clear Sky), (dB)   |                        | 0.2                    |                        |                       | 0.2                    |                       |
| 10. Antenna Pointing Loss, (dB)   |                        | 0.2                    |                        |                       | 0.5                    |                       |
| 11. Receiver <i>G/T</i> , (dB/K)  | 19.3                   | 22.9                   | 25.4                   |                       | 32.6                   |                       |
| 12. Downlink <i>C/N<sub>o</sub></i> , (dB)  | 90.6                   | 94.2                   | 96.7                   |                       | 96.5                   |                       |
| <i>Uplink and Downlink</i>  |                        |                        |                        |                       |                        |                       |
| 13. Overall <i>C/N<sub>o</sub></i> , (dB)   | 88.7                   | 90.7                   | 91.7                   | 76.1                  | 79.5                   | 81.9                  |
| 14. Encoded Information Rate, (dBHz)  |                        | 66.5                   |                        |                       | 57.5                   |                       |
| 15. User Information Rate, (dBHz)   |                        | 63.1                   |                        |                       | 54.1                   |                       |
| 16. <i>C/N</i> Measured in Encoded Signal Bandwidth, (dB)                             | 22.2                   | 24.2                   | 25.1                   | 18.5                  | 22.0                   | 24.4                  |
| 17. Implementation Margin, (dB)   |                        | 2                      |                        |                       | 2                      |                       |
| 18. <i>E<sub>t</sub>/N<sub>o</sub></i> , (dB)   | 17.2                   | 19.2                   | 20.1                   | 13.5                  | 17.0                   | 19.4                  |
| 19. <i>E<sub>b</sub>/N<sub>o</sub></i> Measured in Information Signal Bandwidth, (dB) | 20.6                   | 22.6                   | 23.6                   | 17.0                  | 20.4                   | 22.9                  |
| 20. Clear Sky Bit Error Rate (BER)  | $6.73 \times 10^{-11}$ | $8.87 \times 10^{-12}$ | $3.37 \times 10^{-12}$ | $2.82 \times 10^{-9}$ | $8.18 \times 10^{-11}$ | $6.8 \times 10^{-12}$ |
| 21. Require <i>E<sub>b</sub>/N<sub>o</sub></i> at $10^{-7}$ (dB)                      |                        | 11                     |                        |                       | 11                     |                       |
| 22. Link Margin, (dB)   | 9.6                    | 11.6                   | 12.6                   | 6.0                   | 9.4                    | 11.9                  |

**Table C.2** Link Analysis: Bangkok Hub to Ban Chai Buri (VSAT#3) Link. Hub transmits one coded 4.512 Mbps TDM carrier (outbound) and receive 8 coded 564 kbps SCPC DAMA carriers (inbound). Use Full Transponder of THAICOM-1, in Clear Air.

|  | Hub-to-VSAT#3          |                        |                        | VSAT#3-to-Hub         |                        |                        |
|--|------------------------|------------------------|------------------------|-----------------------|------------------------|------------------------|
|  | Ø 1.2m                 | Ø 1.8m                 | Ø 2.4m                 | Ø 1.2m                | Ø 1.8m                 | Ø 2.4m                 |
| <b>Uplink (14GHz)</b>  |                        |                        |                        |                       |                        |                        |
| 1. Earth Station <i>EIRP</i> , (dBW)                                       |                        | 63                     |                        | 45.7                  | 49.2                   | 51.7                   |
| 2. Uplink Path Loss, (dB)  |                        | 207                    |                        |                       | 207                    |                        |
| 3. Atmospheric Loss (Clear Sky), (dB)                                      |                        | 0.2                    |                        |                       | 0.2                    |                        |
| 4. Antenna Pointing Loss, (dB)   |                        | 0.5                    |                        |                       | 0.2                    |                        |
| 5. Satellite <i>G/T</i> , (dB/K)   |                        | 9.4                    |                        |                       | 9.6                    |                        |
| 6. Uplink <i>C/No</i> , (dB)   |                        | 93.3                   |                        | 76.5                  | 80                     | 82.3                   |
| <b>Downlink (12GHz)</b>  |                        |                        |                        |                       |                        |                        |
| 7. Transponder <i>EIRP</i> /carrier with 3 dB back-off, (dBW)              |                        | 49                     |                        |                       | 41.5                   |                        |
| 8. Downlink Path Loss, (dB)  |                        | 205.5                  |                        |                       | 205.5                  |                        |
| 9. Atmospheric Loss (Clear Sky), (dB)                                      |                        | 0.2                    |                        |                       | 0.2                    |                        |
| 10. Antenna Pointing Loss, (dB)  |                        | 0.2                    |                        |                       | 0.5                    |                        |
| 11. Receiver <i>G/T</i> , (dB/K)   | 19.3                   | 22.9                   | 25.4                   |                       | 32.6                   |                        |
| 12. Downlink <i>C/No</i> , (dB)  | 91                     | 94.6                   | 97.1                   |                       | 96.5                   |                        |
| <b>Uplink and Downlink</b>   |                        |                        |                        |                       |                        |                        |
| 13. Overall <i>C/No</i> , (dB)   | 89.0                   | 90.9                   | 91.8                   | 76.5                  | 79.9                   | 82.3                   |
| 14. Encoded Information Rate, (dBHz)                                       |                        | 66.5                   |                        |                       | 57.5                   |                        |
| 15. User Information Rate, (dBHz)  |                        | 63.1                   |                        |                       | 54.1                   |                        |
| 16. <i>C/N</i> Measured in Encoded Signal Bandwidth, (dB)                  | 22.4                   | 24.3                   | 25.2                   | 18.9                  | 22.4                   | 24.8                   |
| 17. Implementation Margin, (dB)  |                        | 2                      |                        |                       | 2                      |                        |
| 18. <i>E<sub>t</sub>/No</i> , (dB)   | 17.4                   | 19.3                   | 20.2                   | 13.9                  | 17.4                   | 19.8                   |
| 19. <i>E<sub>b</sub>/No</i> Measured in Information Signal Bandwidth, (dB) | 20.9                   | 22.8                   | 23.7                   | 17.4                  | 20.8                   | 23.2                   |
| 20. Clear Sky Bit Error Rate (BER)   | $5.18 \times 10^{-11}$ | $7.42 \times 10^{-12}$ | $2.97 \times 10^{-12}$ | $1.88 \times 10^{-9}$ | $5.48 \times 10^{-11}$ | $4.59 \times 10^{-12}$ |
| 21. Require <i>E<sub>b</sub>/No</i> at $10^{-7}$ (dB)                      |                        | 11                     |                        |                       | 11                     |                        |
| 22. Link Margin, (dB)  | 9.9                    | 11.8                   | 12.7                   | 6.4                   | 9.8                    | 12.2                   |

**Table C.3** Link Analysis: Bangkok Hub to Ban Khemma Marat (VSAT#4) Link. Hub transmits one coded 4.512 Mbps TDM carrier (outbound) and receive 8 coded 564 kbps SCPC DAMA carriers (inbound). Use Full Transponder of THAICOM-1, in Clear Air.

|   | Hub-to-VSAT#4         |                       |                        | VSAT#4-to-Hub         |                        |                       |
|---|-----------------------|-----------------------|------------------------|-----------------------|------------------------|-----------------------|
|   | Ø 1.2m                | Ø 1.8m                | Ø 2.4m                 | Ø 1.2m                | Ø 1.8m                 | Ø 2.4m                |
| <b>Uplink (14GHz)</b>   |                       |                       |                        |                       |                        |                       |
| 1. Earth Station <i>EIRP</i> , (dBW)  |                       | 63                    |                        | 45.7                  | 49.2                   | 51.7                  |
| 2. Uplink Path Loss, (dB)   |                       | 207                   |                        |                       | 207                    |                       |
| 3. Atmospheric Loss (Clear Sky), (dB)   |                       | 0.2                   |                        |                       | 0.2                    |                       |
| 4. Antenna Pointing Loss, (dB)  |                       | 0.5                   |                        |                       | 0.2                    |                       |
| 5. Satellite <i>G/T</i> , (dB/K)  |                       | 9.4                   |                        |                       | 9.2                    |                       |
| 6. Uplink <i>C/N<sub>o</sub></i> , (dB)   |                       | 93.3                  |                        | 76.1                  | 79.6                   | 82.1                  |
| <b>Downlink (12GHz)</b>   |                       |                       |                        |                       |                        |                       |
| 7. Transponder <i>EIRP</i> /carrier with 3 dB back-off, (dBW)                         |                       | 48.8                  |                        |                       | 41.5                   |                       |
| 8. Downlink Path Loss, (dB)   |                       | 205.5                 |                        |                       | 205.5                  |                       |
| 9. Atmospheric Loss (Clear Sky), (dB)   |                       | 0.2                   |                        |                       | 0.2                    |                       |
| 10. Antenna Pointing Loss, (dB)   |                       | 0.2                   |                        |                       | 0.5                    |                       |
| 11. Receiver <i>G/T</i> , (dB/K)  | 19.3                  | 22.9                  | 25.4                   |                       | 32.6                   |                       |
| 12. Downlink <i>C/N<sub>o</sub></i> , (dB)  | 90.8                  | 94.4                  | 96.9                   |                       | 96.5                   |                       |
| <b>Uplink and Downlink</b>  |                       |                       |                        |                       |                        |                       |
| 13. Overall <i>C/N<sub>o</sub></i> , (dB)   | 88.9                  | 90.8                  | 91.7                   | 76.1                  | 79.5                   | 81.9                  |
| 14. Encoded Information Rate, (dBHz)  |                       | 66.5                  |                        |                       | 57.5                   |                       |
| 15. User Information Rate, (dBHz)   |                       | 63.1                  |                        |                       | 54.1                   |                       |
| 16. <i>C/N</i> Measured in Encoded Signal Bandwidth, (dB)                             | 22.3                  | 24.3                  | 25.2                   | 18.5                  | 22.0                   | 24.4                  |
| 17. Implementation Margin, (dB)   |                       | 2                     |                        |                       | 2                      |                       |
| 18. <i>E<sub>t</sub>/N<sub>o</sub></i> , (dB)   | 17.3                  | 19.3                  | 20.2                   | 13.5                  | 17.0                   | 19.4                  |
| 19. <i>E<sub>b</sub>/N<sub>o</sub></i> Measured in Information Signal Bandwidth, (dB) | 20.7                  | 22.7                  | 23.6                   | 17.0                  | 20.4                   | 22.9                  |
| 20. Clear Sky Bit Error Rate (BER)  | $5.9 \times 10^{-11}$ | $8.1 \times 10^{-12}$ | $3.16 \times 10^{-12}$ | $2.82 \times 10^{-9}$ | $8.18 \times 10^{-11}$ | $6.8 \times 10^{-12}$ |
| 21. Require <i>E<sub>b</sub>/N<sub>o</sub></i> at $10^{-7}$ (dB)                      |                       | 11                    |                        |                       | 11                     |                       |
| 22. Link Margin, (dB)   | 9.7                   | 11.7                  | 12.6                   | 6.0                   | 9.4                    | 11.9                  |

**Table C.4** Link Analysis: Bangkok Hub to Ban Khlong Makhm (VSAT#5) Link. Hub transmits one coded 4.512 Mbps TDM carrier (outbound) and receive 8 coded 564 kbps SCPC DAMA carriers (inbound). Use Full Transponder of THAICOM-1, in Clear Air.

|  | Hub-to-VSAT#5          |                        |                       | VSAT#5-to-Hub         |                        |                        |
|--|------------------------|------------------------|-----------------------|-----------------------|------------------------|------------------------|
|  | Ø 1.2m                 | Ø 1.8m                 | Ø 2.4m                | Ø 1.2m                | Ø 1.8m                 | Ø 2.4m                 |
| <i>Uplink (14GHz)</i>                                    |                        |                        |                       |                       |                        |                        |
| 1. Earth Station EIRP, (dBW)                             |                        | 63                     |                       | 45.7                  | 49.2                   | 51.7                   |
| 2. Uplink Path Loss, (dB)                                |                        | 207                    |                       |                       | 207                    |                        |
| 3. Atmospheric Loss (Clear Sky), (dB)                    |                        | 0.2                    |                       |                       | 0.2                    |                        |
| 4. Antenna Pointing Loss, (dB)                           |                        | 0.5                    |                       |                       | 0.2                    |                        |
| 5. Satellite G/T, (dB/K)                                 |                        | 9.4                    |                       |                       | 9.6                    |                        |
| 6. Uplink C/No, (dB)                                     |                        | 93.3                   |                       | 76.5                  | 80                     | 82.5                   |
| <i>Downlink (12GHz)</i>                                  |                        |                        |                       |                       |                        |                        |
| 7. Transponder EIRP/carrier with 3 dB back-off, (dBW)    |                        | 50.1                   |                       |                       | 41.5                   |                        |
| 8. Downlink Path Loss, (dB)                              |                        | 205.5                  |                       |                       | 205.5                  |                        |
| 9. Atmospheric Loss (Clear Sky), (dB)                    |                        | 0.2                    |                       |                       | 0.2                    |                        |
| 10. Antenna Pointing Loss, (dB)                          |                        | 0.2                    |                       |                       | 0.5                    |                        |
| 11. Receiver G/T, (dB/K)                                 | 19.3                   | 22.9                   | 25.4                  |                       | 32.6                   |                        |
| 12. Downlink C/No, (dB)                                  | 92.1                   | 95.7                   | 98.2                  |                       | 96.5                   |                        |
| <i>Uplink and Downlink</i>                               |                        |                        |                       |                       |                        |                        |
| 13. Overall C/No, (dB)                                   | 89.6                   | 91.3                   | 92.1                  | 76.5                  | 79.9                   | 82.3                   |
| 14. Encoded Information Rate, (dBHz)                     |                        | 66.5                   |                       |                       | 57.5                   |                        |
| 15. User Information Rate, (dBHz)                        |                        | 63.1                   |                       |                       | 54.1                   |                        |
| 16. C/N Measured in Encoded Signal Bandwidth, (dB)       | 23.1                   | 24.8                   | 25.5                  | 18.9                  | 22.4                   | 24.8                   |
| 17. Implementation Margin, (dB)                          |                        | 2                      |                       |                       | 2                      |                        |
| 18. Et/No, (dB)  | 18.1                   | 19.8                   | 20.5                  | 13.9                  | 17.4                   | 19.8                   |
| 19. Eb/No Measured in Information Signal Bandwidth, (dB) | 21.5                   | 23.2                   | 24.0                  | 17.4                  | 20.8                   | 23.2                   |
| 20. Clear Sky Bit Error Rate (BER)                       | $2.64 \times 10^{-11}$ | $4.76 \times 10^{-12}$ | $2.2 \times 10^{-12}$ | $1.88 \times 10^{-9}$ | $5.48 \times 10^{-11}$ | $4.59 \times 10^{-12}$ |
| 21. Require Eb/No at $10^{-7}$ (dB)                      |                        | 11                     |                       |                       | 11                     |                        |
| 22. Link Margin, (dB)                                    | 10.5                   | 12.2                   | 13.0                  | 6.4                   | 9.8                    | 12.2                   |

**Table C.5** Link Analysis: Bangkok Hub to Phuket (VSAT#6) Link. Hub transmits one coded 4.512 Mbps TDM carrier (outbound) and receive 8 coded 564 kbps SCPC DAMA carriers (inbound). Use Full Transponder of THAICOM-1, in Clear Air.

|   | Hub-to-VSAT#6          |                        |                        | VSAT#6-to-Hub         |                        |                        |
|---|------------------------|------------------------|------------------------|-----------------------|------------------------|------------------------|
|   | Ø 1.2m                 | Ø 1.8m                 | Ø 2.4m                 | Ø 1.2m                | Ø 1.8m                 | Ø 2.4m                 |
| <b>Uplink (14GHz)</b>   |                        |                        |                        |                       |                        |                        |
| 1. Earth Station <i>EIRP</i> , (dBW)                            |                        | 63                     |                        | 45.7                  | 49.2                   | 51.7                   |
| 2. Uplink Path Loss, (dB)                                       |                        | 207                    |                        |                       | 207                    |                        |
| 3. Atmospheric Loss (Clear Sky), (dB)                           |                        | 0.2                    |                        |                       | 0.2                    |                        |
| 4. Antenna Pointing Loss, (dB)                                  |                        | 0.5                    |                        |                       | 0.2                    |                        |
| 5. Satellite <i>G/T</i> , (dB/K)                                |                        | 9.4                    |                        |                       | 10.1                   |                        |
| 6. Uplink <i>C/No</i> , (dB)                                    |                        | 93.3                   |                        | 77                    | 80.5                   | 83                     |
| <b>Downlink (12GHz)</b>   |                        |                        |                        |                       |                        |                        |
| 7. Transponder <i>EIRP</i> /carrier with 3 dB back-off, (dBW)   |                        | 49.3                   |                        |                       | 41.5                   |                        |
| 8. Downlink Path Loss, (dB)                                     |                        | 205.5                  |                        |                       | 205.5                  |                        |
| 9. Atmospheric Loss (Clear Sky), (dB)                           |                        | 0.2                    |                        |                       | 0.2                    |                        |
| 10. Antenna Pointing Loss, (dB)                                 |                        | 0.2                    |                        |                       | 0.5                    |                        |
| 11. Receiver <i>G/T</i> , (dB/K)                                | 19.3                   | 22.9                   | 25.4                   |                       | 32.6                   |                        |
| 12. Downlink <i>C/No</i> , (dB)                                 | 91.3                   | 94.9                   | 97.4                   |                       | 96.5                   |                        |
| <b>Uplink and Downlink</b>                                      |                        |                        |                        |                       |                        |                        |
| 13. Overall <i>C/No</i> , (dB)                                  | 89.2                   | 91.0                   | 91.9                   | 77.0                  | 80.4                   | 82.8                   |
| 14. Encoded Information Rate, (dBHz)                            |                        | 66.5                   |                        |                       | 57.5                   |                        |
| 15. User Information Rate, (dBHz)                               |                        | 63.1                   |                        |                       | 54.1                   |                        |
| 16. <i>C/N</i> Measured in Encoded Signal Bandwidth, (dB)       | 22.6                   | 24.5                   | 25.3                   | 19.4                  | 22.9                   | 25.3                   |
| 17. Implementation Margin, (dB)                                 |                        | 2                      |                        |                       | 2                      |                        |
| 18. <i>Et/No</i> , (dB)   | 17.6                   | 19.5                   | 20.3                   | 14.4                  | 17.9                   | 20.3                   |
| 19. <i>Eb/No</i> Measured in Information Signal Bandwidth, (dB) | 21.1                   | 22.9                   | 23.8                   | 17.9                  | 21.3                   | 23.7                   |
| 20. Clear Sky Bit Error Rate (BER)                              | $4.28 \times 10^{-11}$ | $6.53 \times 10^{-12}$ | $2.72 \times 10^{-12}$ | $1.13 \times 10^{-9}$ | $3.32 \times 10^{-11}$ | $2.81 \times 10^{-12}$ |
| 21. Require <i>Eb/No</i> at $10^{-7}$ (dB)                      |                        | 11                     |                        |                       | 11                     |                        |
| 22. Link Margin, (dB)   | 10.1                   | 11.9                   | 12.8                   | 6.9                   | 10.3                   | 12.7                   |

**Table C.6** Link Analysis: Bangkok Hub to Rangae (VSAT#7) Link. Hub transmits one coded 4.512 Mbps TDM carrier (outbound) and receive 8 coded 564 kbps SCPC DAMA carriers (inbound). Use Full Transponder of THAICOM-1, in Clear Air.

|  | Hub-to-VSAT#7          |                        |                        | VSAT#7-to-Hub         |                        |                        |
|--|------------------------|------------------------|------------------------|-----------------------|------------------------|------------------------|
|  | Ø 1.2m                 | Ø 1.8m                 | Ø 2.4m                 | Ø 1.2m                | Ø 1.8m                 | Ø 2.4m                 |
| <i>Uplink (14GHz)</i>  |                        |                        |                        |                       |                        |                        |
| 1. Earth Station <i>EIRP</i> , (dBW)                                       |                        | 63                     |                        | 45.7                  | 49.2                   | 51.7                   |
| 2. Uplink Path Loss, (dB)  |                        | 207                    |                        |                       | 207                    |                        |
| 3. Atmospheric Loss (Clear Sky), (dB)                                      |                        | 0.2                    |                        |                       | 0.2                    |                        |
| 4. Antenna Pointing Loss, (dB)   |                        | 0.5                    |                        |                       | 0.2                    |                        |
| 5. Satellite <i>G/T</i> , (dB/K)   |                        | 9.4                    |                        |                       | 8.1                    |                        |
| 6. Uplink <i>C/No</i> , (dB)   |                        | 93.3                   |                        | 75                    | 78.5                   | 81                     |
| <i>Downlink (12GHz)</i>  |                        |                        |                        |                       |                        |                        |
| 7. Transponder <i>EIRP</i> /carrier with 3 dB back-off, (dBW)              |                        | 48                     |                        |                       | 41.5                   |                        |
| 8. Downlink Path Loss, (dB)  |                        | 205.5                  |                        |                       | 205.5                  |                        |
| 9. Atmospheric Loss (Clear Sky), (dB)                                      |                        | 0.2                    |                        |                       | 0.2                    |                        |
| 10. Antenna Pointing Loss, (dB)  |                        | 0.2                    |                        |                       | 0.5                    |                        |
| 11. Receiver <i>G/T</i> , (dB/K)   | 19.3                   | 22.9                   | 25.4                   |                       | 32.6                   |                        |
| 12. Downlink <i>C/No</i> , (dB)  | 90                     | 93.6                   | 96.1                   |                       | 96.5                   |                        |
| <i>Uplink and Downlink</i>   |                        |                        |                        |                       |                        |                        |
| 13. Overall <i>C/No</i> , (dB)   | 88.3                   | 90.4                   | 91.5                   | 75.0                  | 78.4                   | 80.9                   |
| 14. Encoded Information Rate, (dBHz)                                       |                        | 66.5                   |                        |                       | 57.5                   |                        |
| 15. User Information Rate, (dBHz)  |                        | 63.1                   |                        |                       | 54.1                   |                        |
| 16. <i>C/N</i> Measured in Encoded Signal Bandwidth, (dB)                  | 21.8                   | 23.9                   | 24.9                   | 17.5                  | 20.9                   | 23.4                   |
| 17. Implementation Margin, (dB)  |                        | 2                      |                        |                       | 2                      |                        |
| 18. <i>E<sub>t</sub>/No</i> , (dB)   | 16.8                   | 18.9                   | 19.9                   | 12.5                  | 15.9                   | 18.4                   |
| 19. <i>E<sub>b</sub>/No</i> Measured in Information Signal Bandwidth, (dB) | 20.2                   | 22.3                   | 23.4                   | 15.9                  | 19.3                   | 21.8                   |
| 20. Clear Sky Bit Error Rate (BER)   | $1.01 \times 10^{-11}$ | $1.18 \times 10^{-11}$ | $4.12 \times 10^{-12}$ | $8.66 \times 10^{-9}$ | $2.47 \times 10^{-11}$ | $2.02 \times 10^{-12}$ |
| 21. Require <i>E<sub>b</sub>/No</i> at $10^{-7}$ (dB)                      |                        | 11                     |                        |                       | 11                     |                        |
| 22. Link Margin, (dB)  | 9.2                    | 11.3                   | 12.4                   | 4.9                   | 8.3                    | 10.8                   |

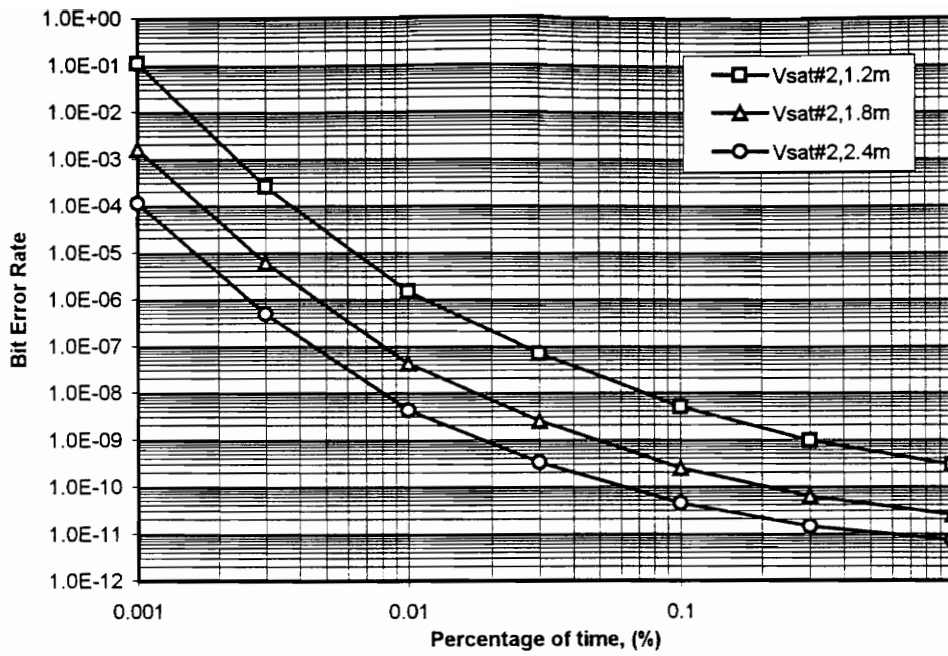

**Figure C.1** BER Vs. Percentage of time, under rain conditions at downlink for Hub-to-VSAT#2 link, using full transponder power

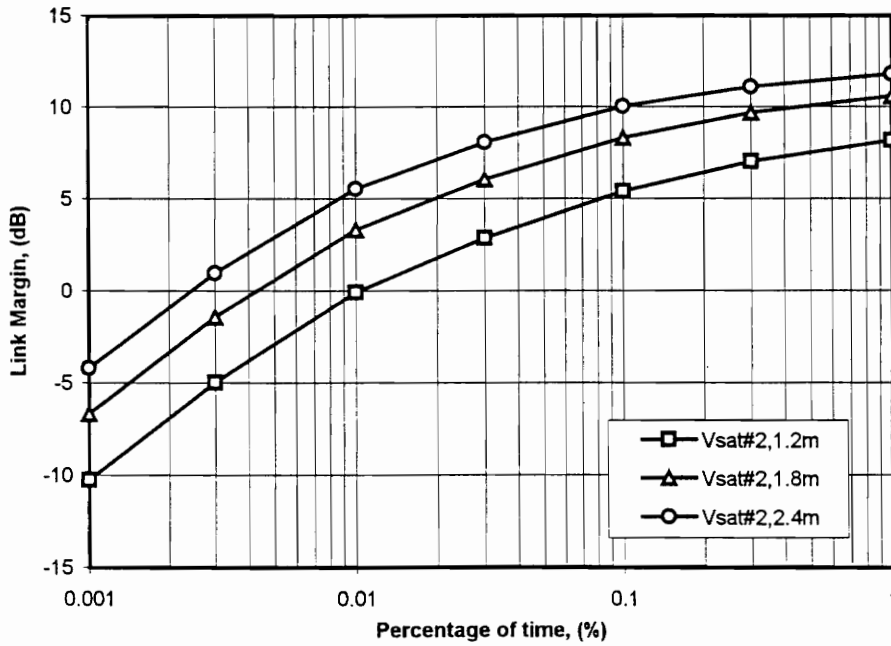

**Figure C.2** Link Margin Vs. Percentage of time, under rain conditions at downlink for Hub-to-VSAT#2 link, using full transponder power

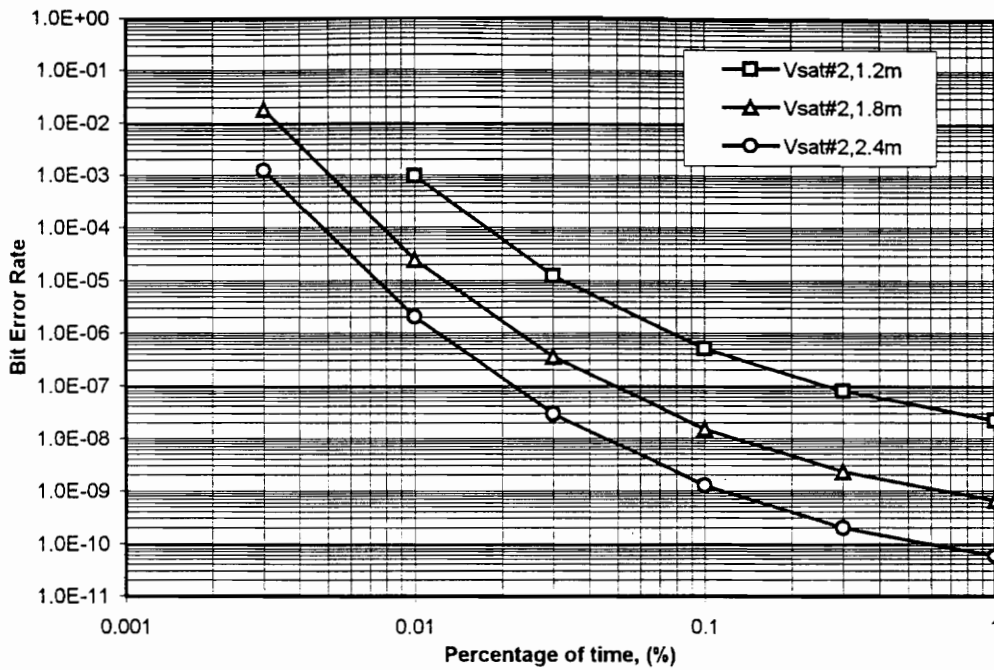

**Figure C.3** BER Vs. Percentage of time, under rain conditions at uplink for VSAT#2-to-Hub link, using full transponder power

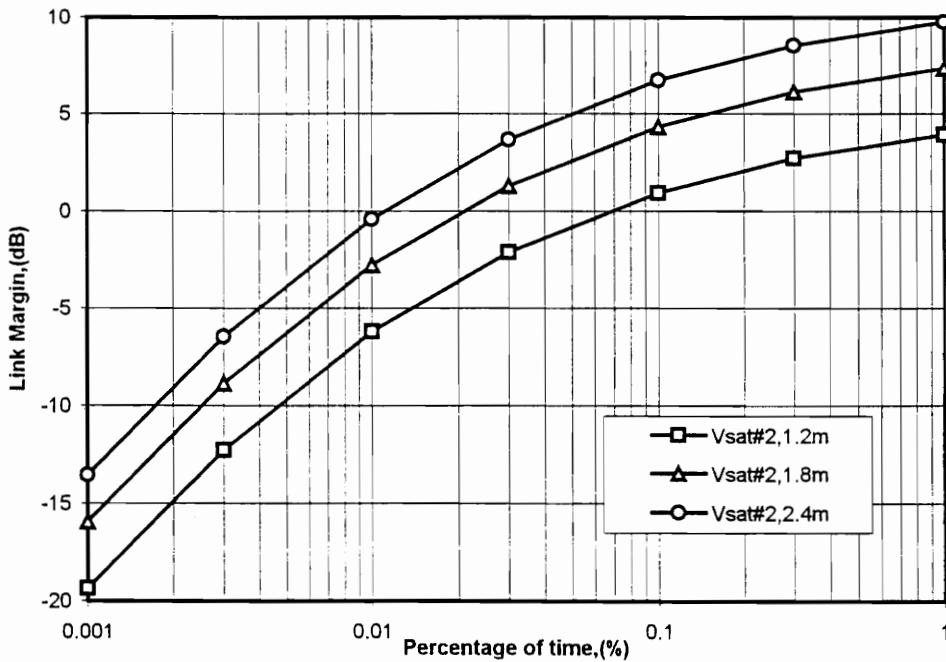

**Figure C.4** Link Margin Vs. Percentage of time, under rain conditions at uplink for VSAT#2-to-Hub link, using full transponder power

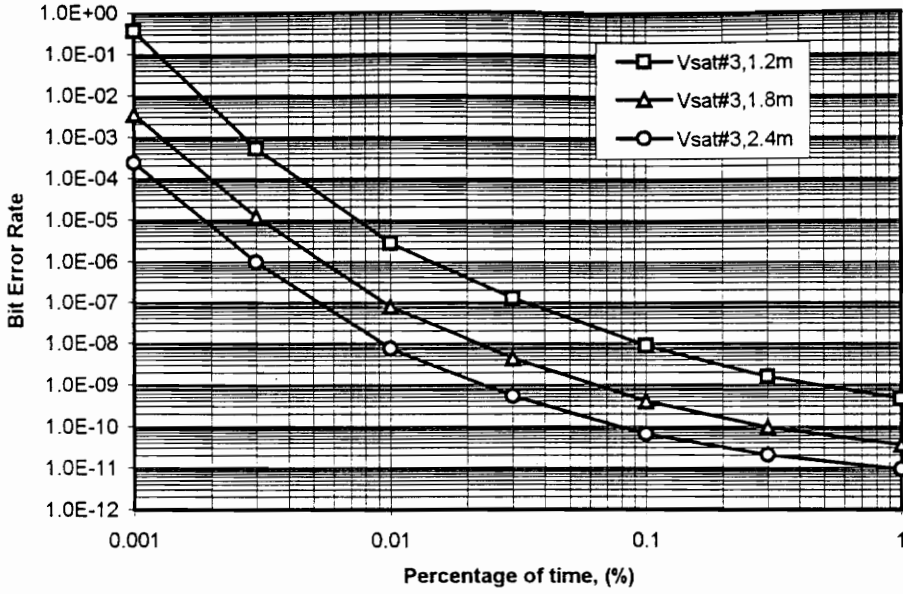

**Figure C.5** BER Vs. Percentage of time, under rain conditions at downlink for Hub-to-VSAT#3 link, using full transponder power

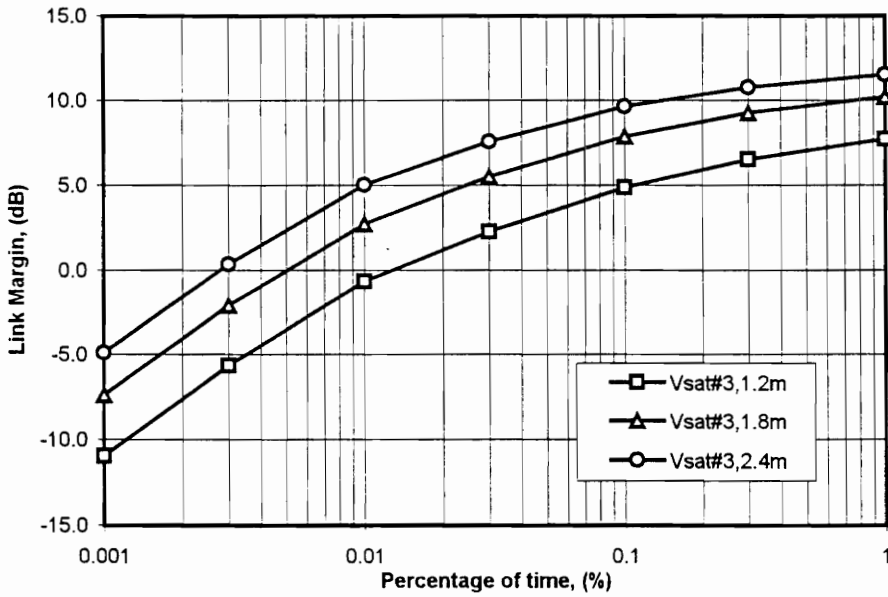

**Figure C.6** Link Margin Vs. Percentage of time, under rain conditions at downlink for Hub-to-VSAT#3 link, using full transponder power

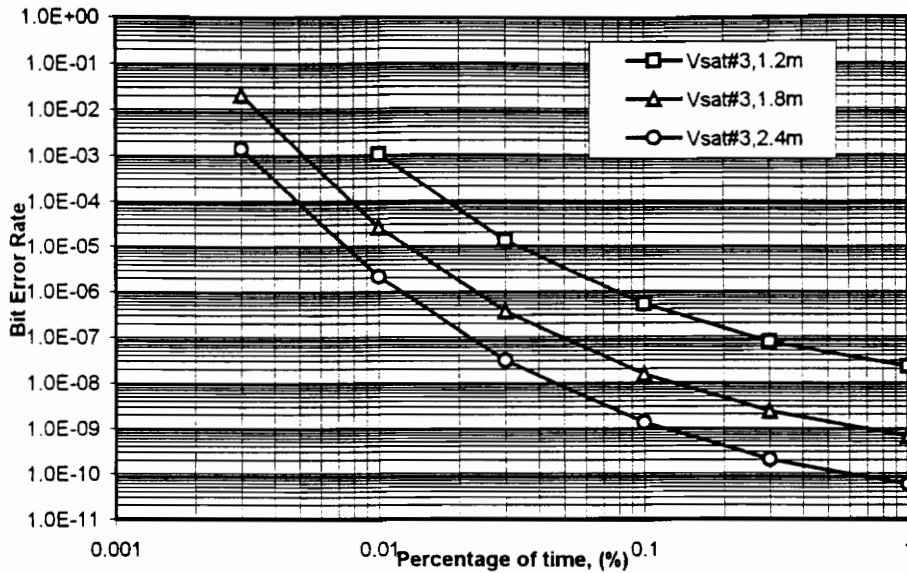

**Figure C.7** BER Vs. Percentage of time, under rain conditions at uplink for VSAT#3-to-Hub link, using full transponder power

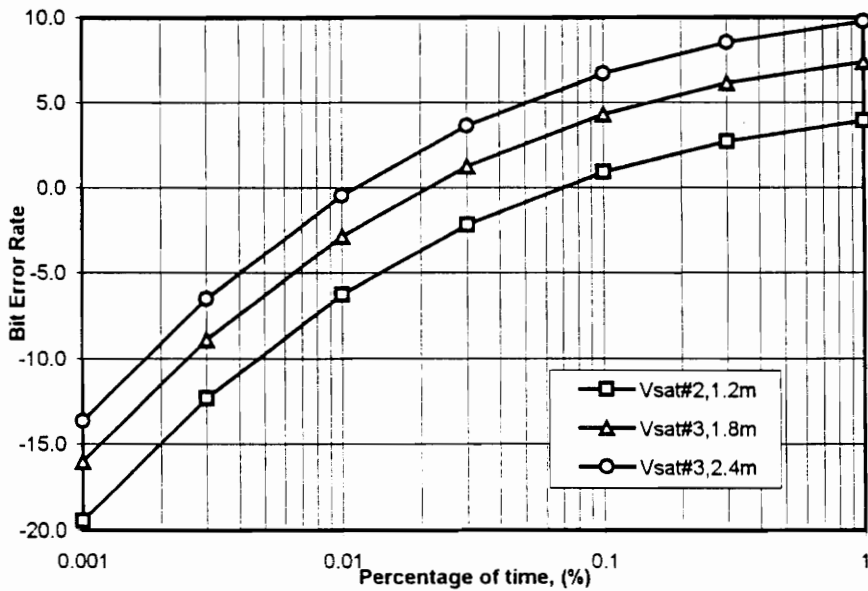

**Figure C.8** Link Margin Vs. Percentage of time, under rain conditions at uplink for VSAT#3-to-Hub link, using full transponder power

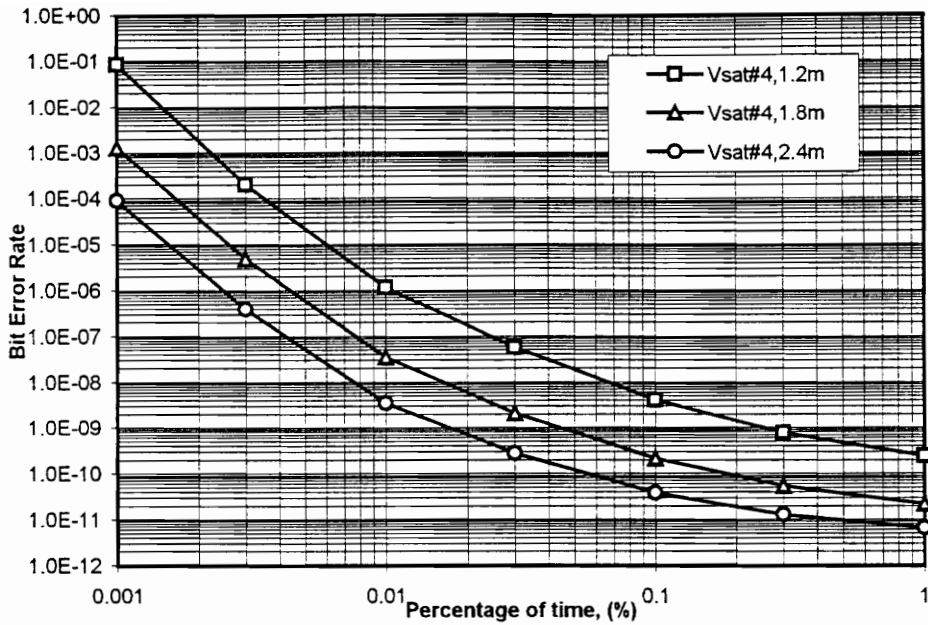

**Figure C.9** BER Vs. Percentage of time, under rain conditions at downlink for Hub-to-VSAT#4 link, using full transponder power

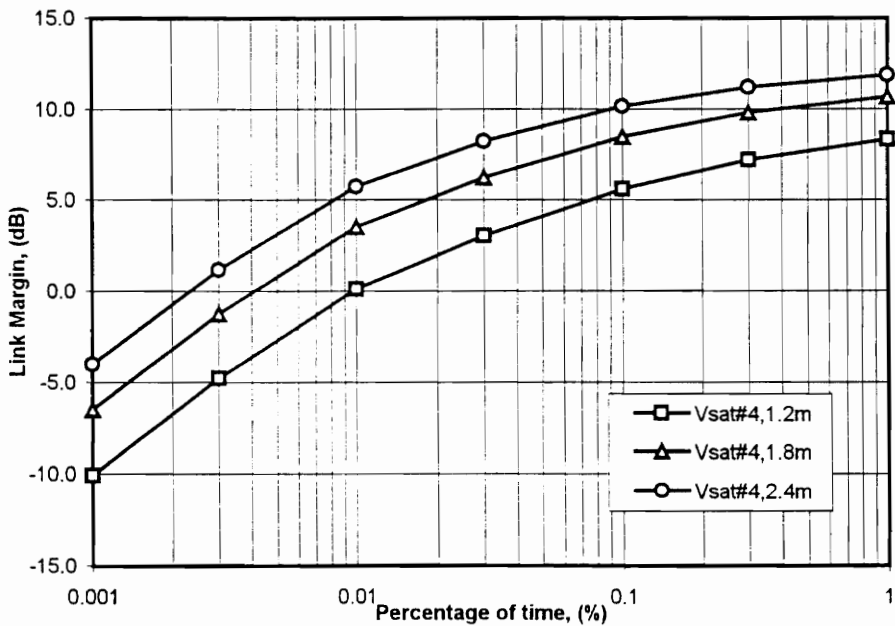

**Figure C.10** Link Margin Vs. Percentage of time, under rain conditions at downlink for Hub-to-VSAT#4 link, using full transponder power

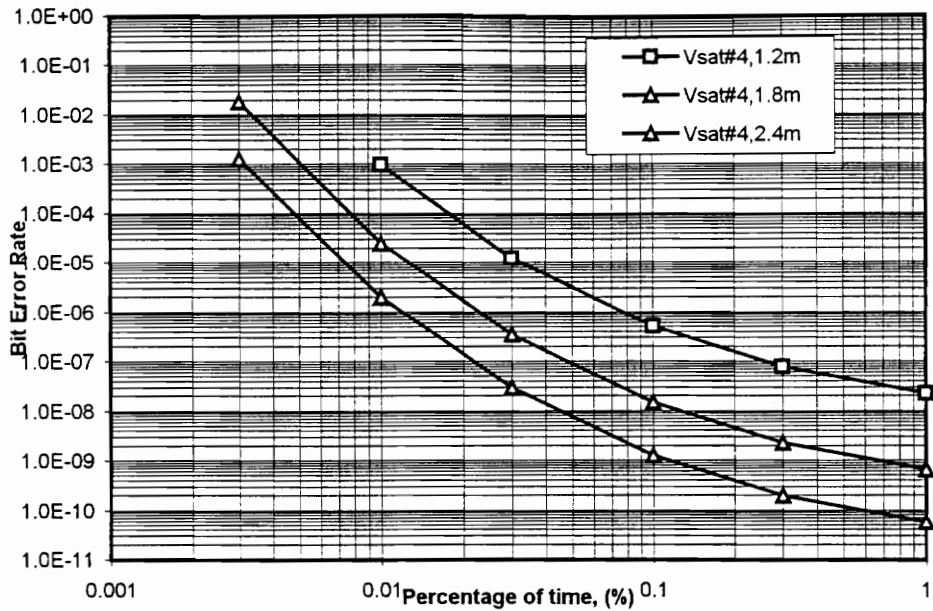

**Figure C.11** BER Vs. Percentage of time, under rain conditions at uplink for VSAT#4-to-Hub link, using full transponder power

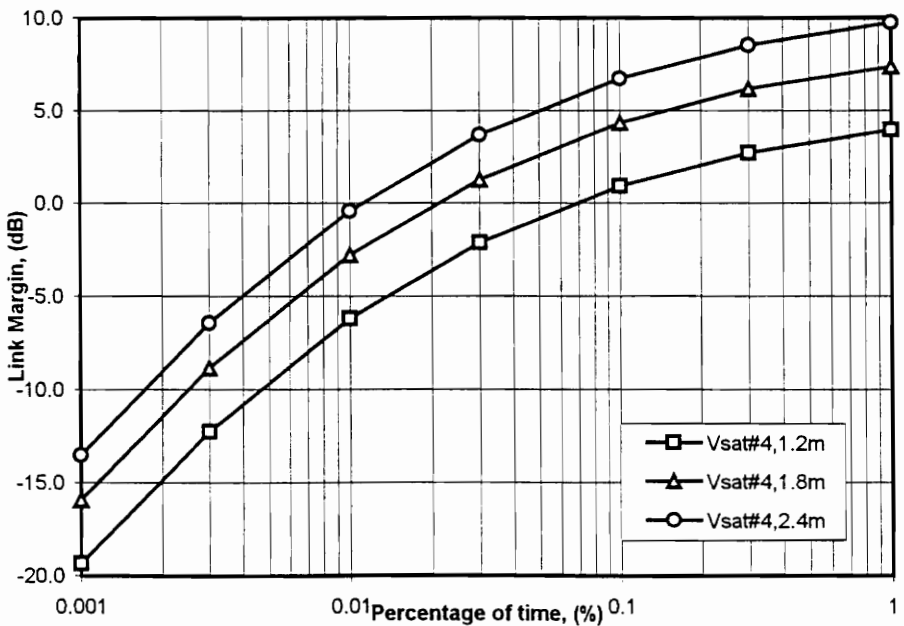

**Figure C.12** Link Margin Vs. Percentage of time, under rain conditions at uplink for VSAT#4-to-Hub link, using full transponder power

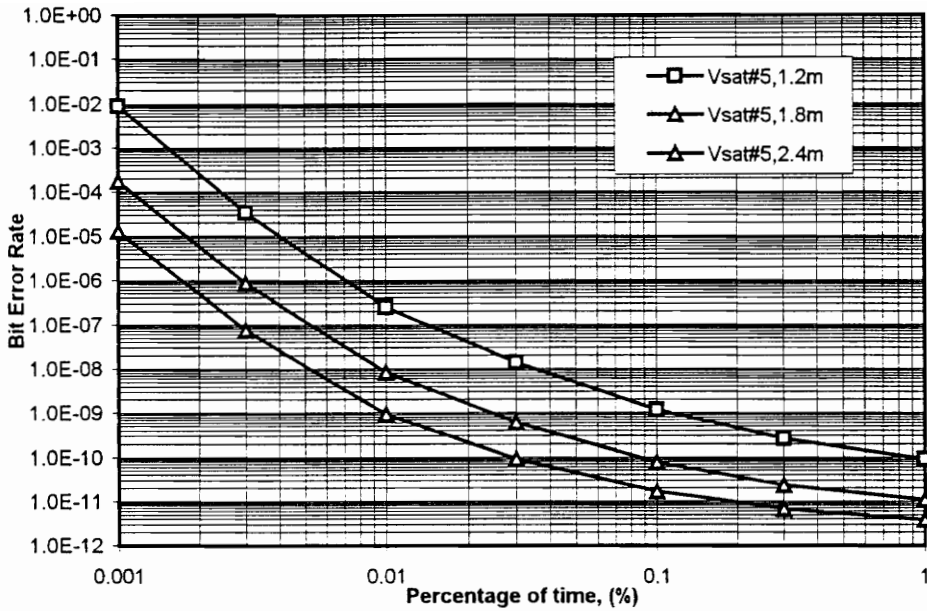

**Figure C.13** BER Vs. Percentage of time, under rain conditions at downlink for Hub-to-VSAT#5 link, using full transponder power

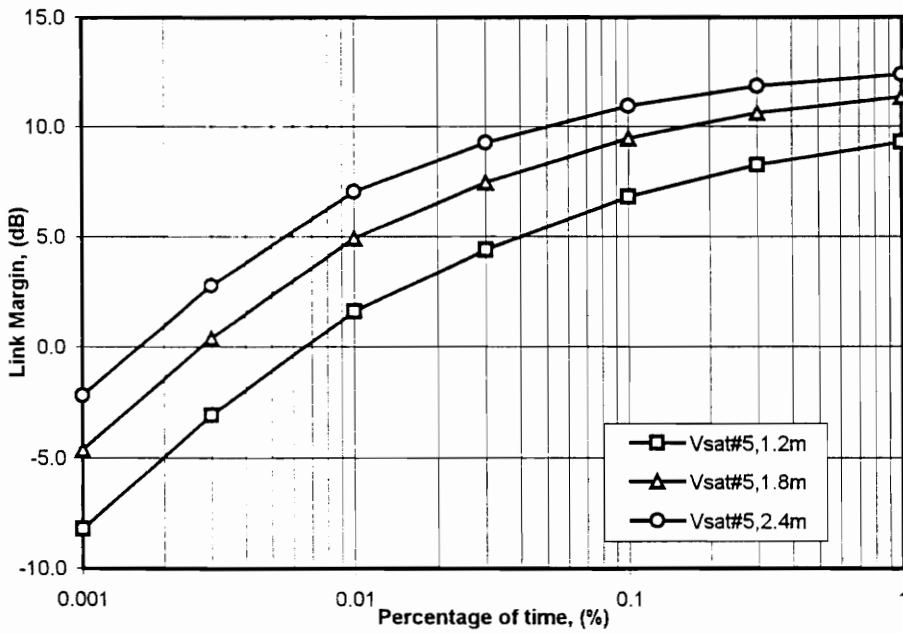

**Figure C.14** Link Margin Vs. Percentage of time, under rain conditions at downlink for Hub-to-VSAT#5 link, using full transponder power

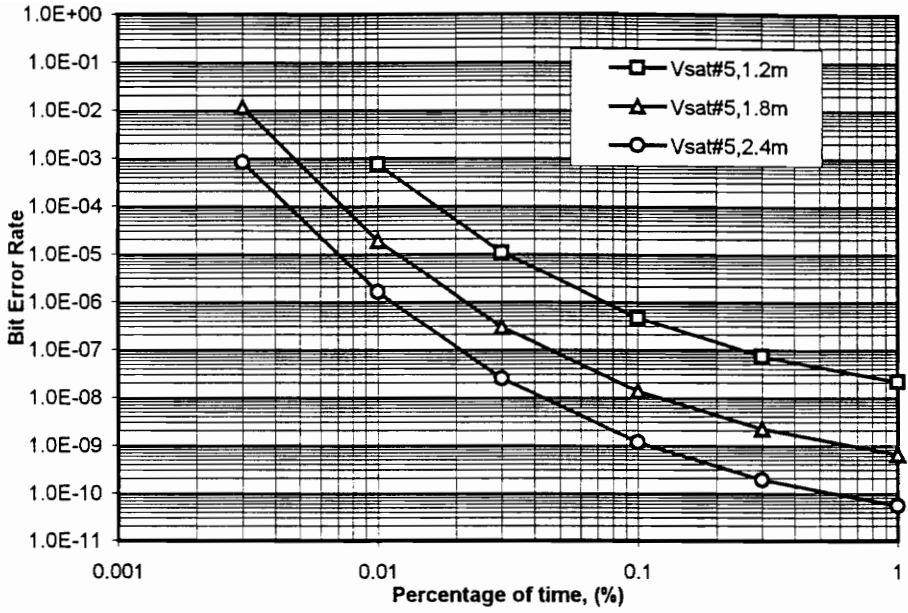

**Figure C.15** BER Vs. Percentage of time, under rain conditions at uplink for VSAT#5-to-Hub link, using full transponder power

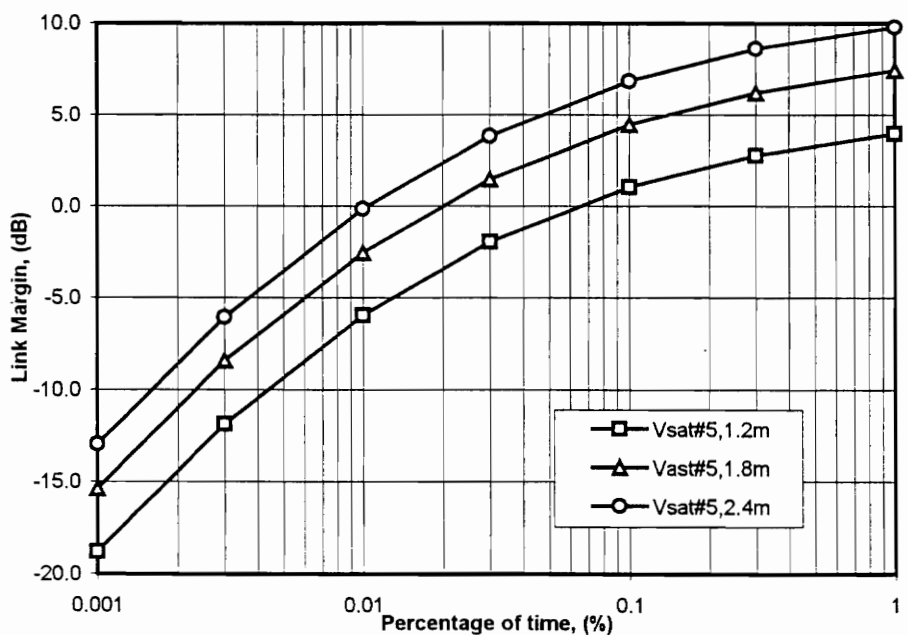

**Figure C.16** Link Margin Vs. Percentage of time, under rain conditions at uplink for VSAT#5-to-Hub link, using full transponder power

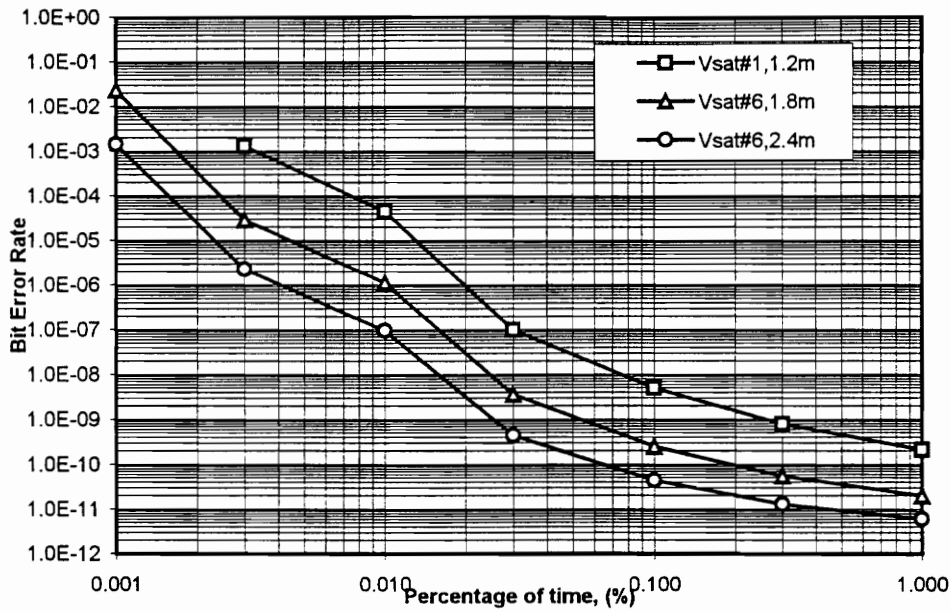

**Figure C.17** BER Vs. Percentage of time, under rain conditions at downlink for Hub-to-VSAT#6 link, using full transponder power

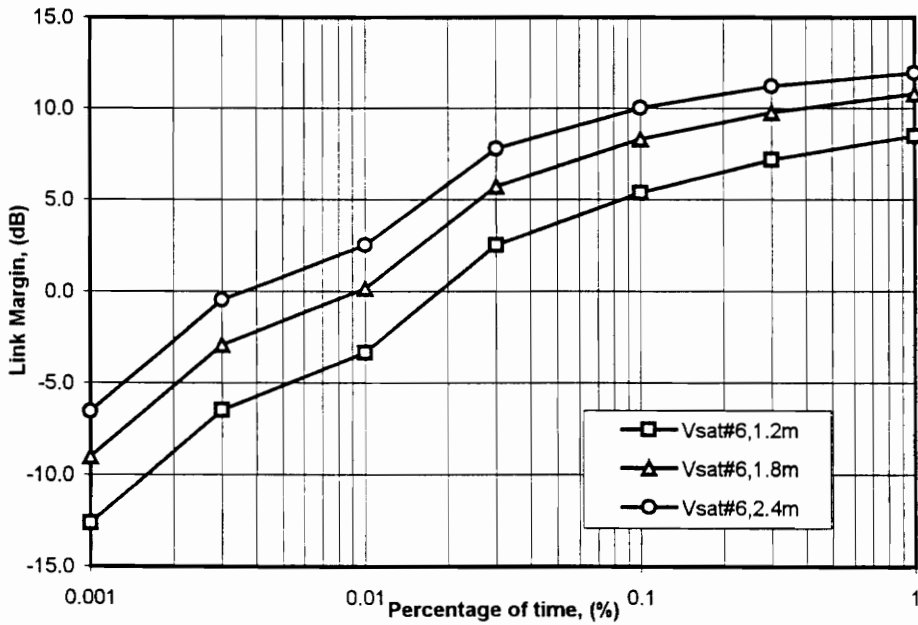

**Figure C.18** Link Margin Vs. Percentage of time, under rain conditions at downlink for Hub-to-VSAT#6 link, using full transponder power

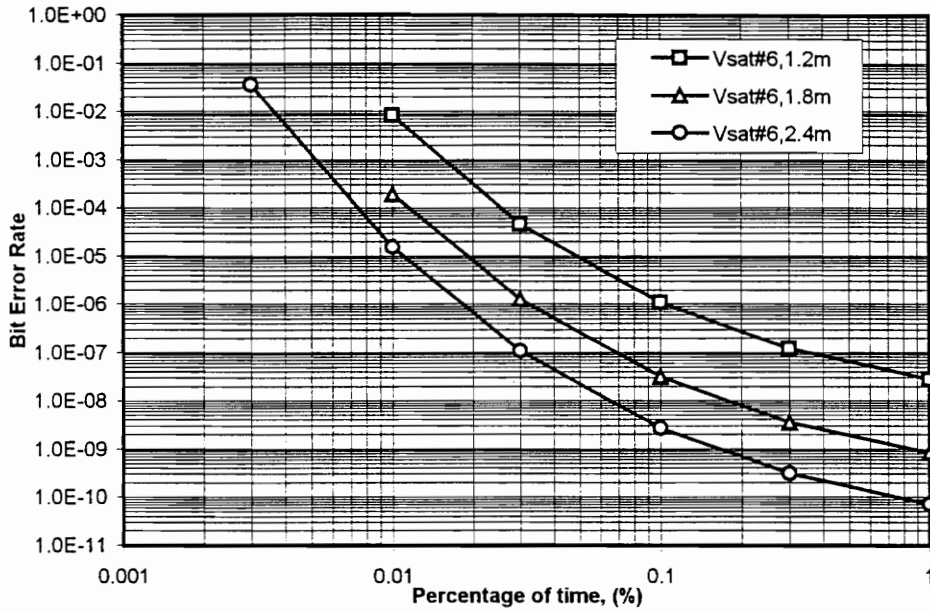

**Figure C.19** BER Vs. Percentage of time, under rain conditions at uplink for VSAT#6-to-Hub link, using full transponder power

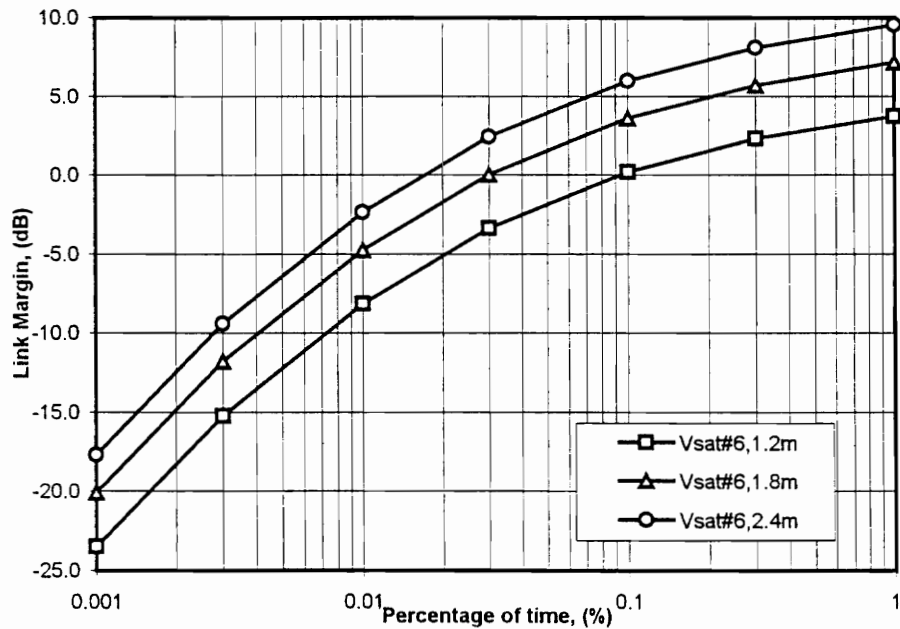

**Figure C.20** Link Margin Vs. Percentage of time, under rain conditions at uplink for VSAT#6-to-Hub link, using full transponder power

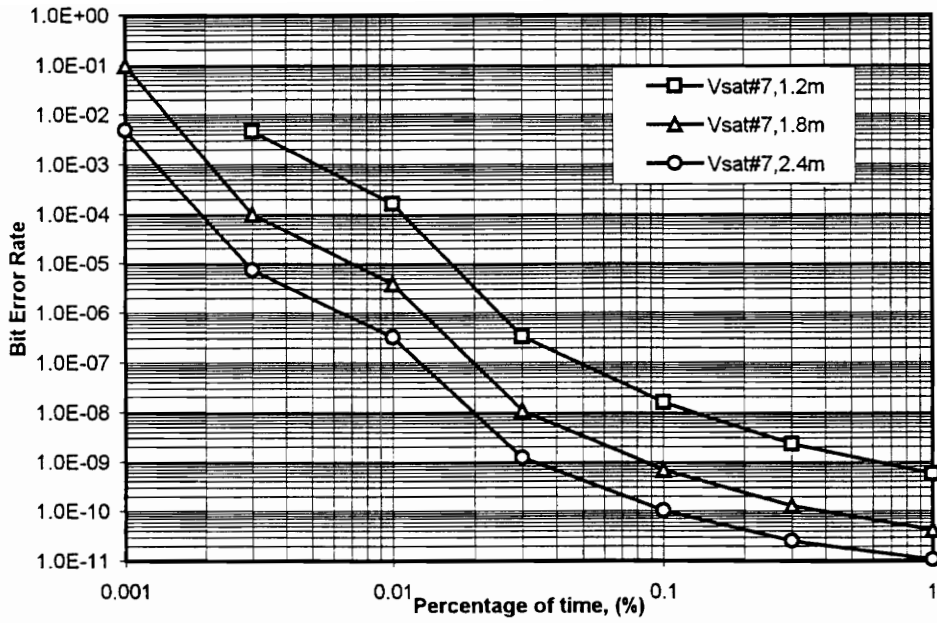

**Figure C.21** BER Vs. Percentage of time, under rain conditions at downlink for Hub-to-VSAT#7 link, using full transponder power

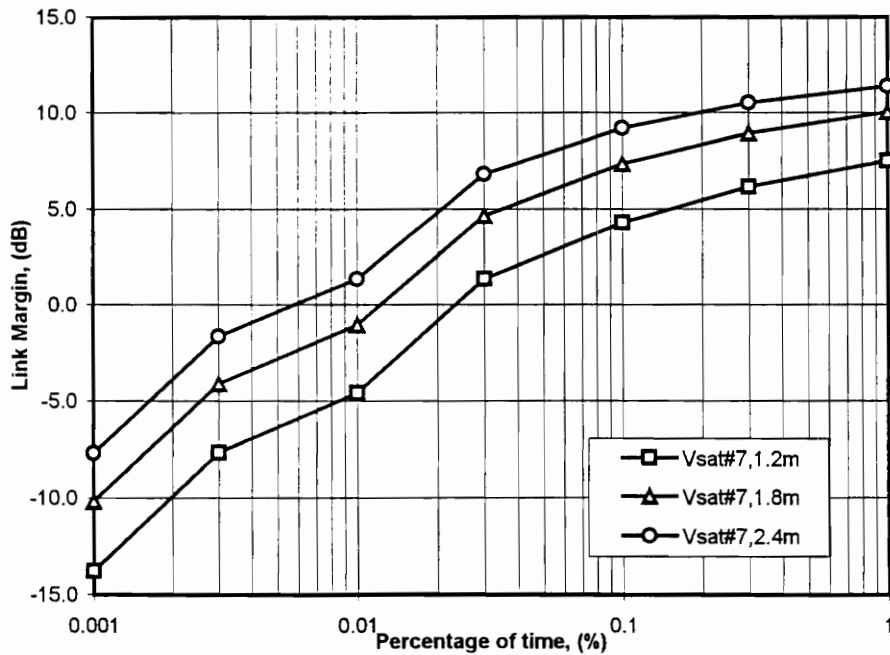

**Figure C.22** Link Margin Vs. Percentage of time, under rain conditions at downlink for Hub-to-VSAT#7 link, using full transponder power

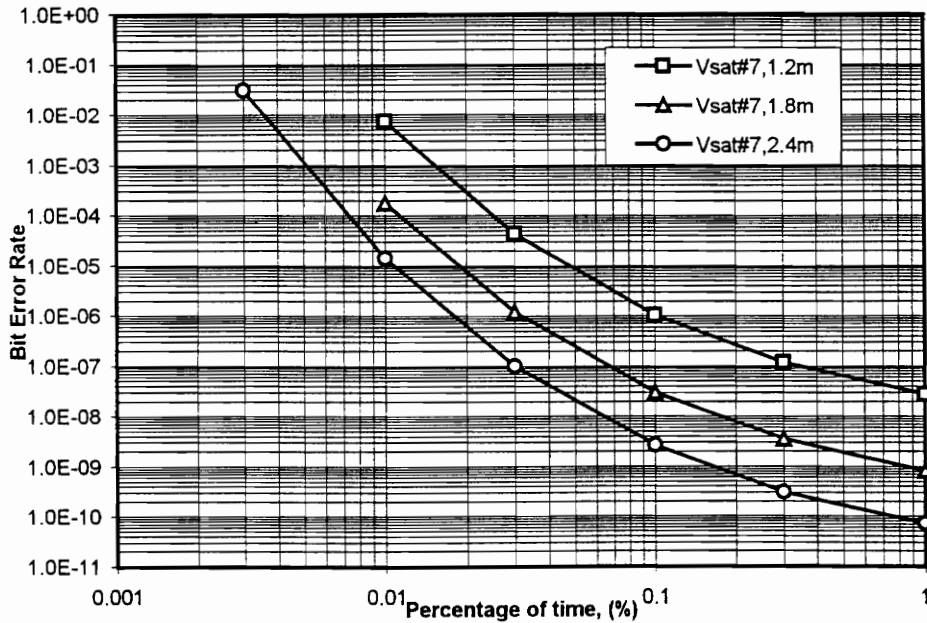

**Figure C.23** BER Vs. Percentage of time, under rain conditions at uplink for VSAT#7-to-Hub link, using full transponder power

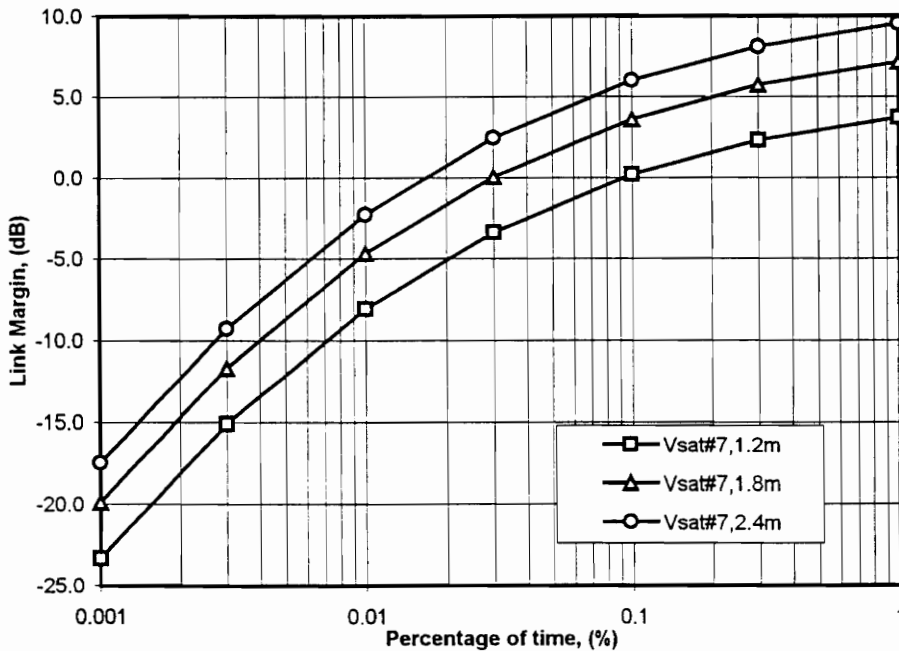

**Figure C.24** Link Margin Vs. Percentage of time, under rain conditions at uplink for VSAT#7-to-Hub link, using full transponder power

## Vita

Kanokporn Kunchaicharoenkul was born in Udonthani, Thailand on July 13, 1970. She attended St. Mary's school, Udonthani from 1976 to 1985 and Udonpittayanukul school, Udonthani from 1985 to 1988. She attended King Mongkut's Institute of Technology Ladkrabang, Bangkok from 1988 to 1992. She received the Bachelor of Engineering degree in Electronics in 1992. After graduation, she worked for Acumen Company on satellite communications systems. Her responsibilities mainly dealt with the TDMA domestic satellite network which is a telephone domestic communication via satellite. In 1994, she was awarded a scholarship from the government of Thailand to pursue her studies towards Master's degree in Electrical Engineering , specializing in Communications at Virginia Polytechnic Institute and State University. After obtaining her Master of Science degree, she will be placed in the office of frequency management as an communications engineer responsible for planning the national telecommunication plan and project, especially satellite communications, for Thailand.

*K. Kanokporn*