

Chapter 2: Triboelectric Charging of Coal, Quartz and Pyrite by In-line Mixer

(ABSTRACT)

An evaluation of particle charging properties and process parameters that affect particle charge is of great significance in triboelectrostatic separation for dry coal cleaning. The tribocharging characteristics of the Pittsburgh No. 8 coal and the ash-forming mineral (i.e. quartz, pyrite) samples were thus investigated by the use of a copper in-line static-mixer, which has been well chosen to serve as a tribocharger during the study. The new developed charge-measuring device, “the on-line tribocharge analyzer,” has proved possible to achieve satisfactory and reliable charge measurements. A description of the device is discussed. The coal and mineral samples were found to acquire their charge oppositely; that is, the coal sample was charged positively whereas the mineral samples were negatively charged. Five main parameters were studied during this study; i.e. air velocity, particle feed rate, particle size, ash content and temperature. The data obtained from the investigations are presented and the effects of the studied parameters on the charge characteristics of the particles are discussed.

2.1 Introduction

Numerous advanced coal beneficiation processes have been developed in recent years. Many of them are capable of substantially reducing both ash- and sulfur-forming minerals from coal. However, most of the widely used physical coal cleaning technologies (Yoon, 1991) are wet processes, in which the dewatering constitutes a large part of its cost. One way to avoid this problem would be developed dry processes.

Electrostatic separation for coal beneficiation has received a great deal of attention in recent years as a promising dry method. The separation process is based on exploiting the difference in electrical charging characteristics between coal and mineral matters. In this process, particles to be separated are charged differently and passed through an electric field to effect the separation (Inculet, 1984). It is noted that the electrostatic separation processes depend originally on the methods of charging particles (Inculet, 1984; Ralston, 1961). For this reason, the design of a separating machine is usually a reflection of the type of charging mechanism. Although there are many ways to cause the particles to acquire electric charge, only three charging mechanisms have been able to make their applications to the commercial electrostatic separations (Yoon, 1991; Inculet, 1984; Ralston, 1961, Kelly and Spottiswood, 1982; Harper, 1967): i.e., i) ion or electron bombardments, ii) conductive induction, and iii) contact or friction electrification (triboelectrification). Among the acknowledged methods of particle charging, triboelectrification has currently been of significance in the processes of coal and minerals beneficiation, as a result of its effectiveness and less energy requirement.

Theoretically, tribocharging is the process, in which one type of material (particle) selectively acquires charge when it contacts with dissimilar material. The two materials can be any combination of conductor, semiconductor, or insulator (dielectric). Usually, the contact electrification mechanism is explained by means of the work function; that is, when two materials with different work functions are brought into intimate contact, electrons will flow from the one of lower work function to the one of higher work function. Charge will flow in a direction determined by this work function parameter until the Fermi levels of the two materials become equal. The work function of a material is defined as the energy lost when an electron moves from just outside to inside the material. It is governed by the energy of the Fermi level, E_F . Although it is ordinarily thought that contact charging is the result of electron transfer from one body to another (Robinson, 1969; Seanor, 1972; Lowell and Rose-Innes, 1980; Kelly and Spottiswood, 1989; Rose-Innes, 1980), there is evidence, however, in some circumstances that the charge transfer in contact charging can occur by ions (Harper, 1967; Gaudin, 1971), or by transferred materials which carry charge (Salanek, 1976). In the analysis of the charge remaining on the materials after contact electrification, it is conceivable that the magnitude of the final

charge on the materials is the result of two processes: i.e., i) the charge transfer that occurs during the contact, and ii) the charge backflow that occurs as the materials are separated (Inculet, 1984; Lowell and Rose-Innes, 1980; Kelly and Spottiswood, 1989).

For electrostatic beneficiation of coal, the triboelectrification method for particle charging dates back to the early of this century (Blacktin, 1931). It is based on the premise that coal and mineral matters can be triboelectrostatically charged selectively when a material is appropriately chosen to be the contact surface. As it is obvious that a sufficient degree of charge generated on the particles and adequate selectivity are ones of the key factors for triboelectrostatic separating achievement, large amounts of research and development effort have thus been aimed at the charging step. Early triboelectrostatic separators commonly had particles sliding down, or transported through chutes, pipe, or nozzles (Lockhart, 1984), then followed by free-fall through an electric field that deflects the particles according to the sign and magnitude of their charge. Up to present, the application of this type of particle tribocharging system has still been the subject of study by researchers (Nieh and Nguyen, 1987; Schaefer, et.al., 1994; Link, et.al., 1990; Finseth, et.al., 1993) in the field of triboelectrostatic separation.

During the past decades, numerous studies have been conducted in many ways such as to improve the charging efficiency. For this reason, cyclone (Carbini, et.al., 1982; Mazuda, et.al., 1983) and fluidized bed (Inculet, et.al., 1980a; 1980b) have become the techniques of choice for particle charging in coal triboelectrostatic beneficiation, as they are known to provide better particle-wall and particle-particle contacts. For coal desulfurization, Gidaspow, et.al. (1987) pioneered a design concept called “electrostatic sieve”, which is based on the principle of fluidization. The average charge on particles was then measured by using a developed “electrostatic ball probe”.

Despite the fact that an in-line static mixer, as a tribocharger, has already been tested and proved its feasibility (Finseth, et.al., 1993), still crucial information for the particle charging mechanism have yet to emerge. In this paper, the experimental system was originatively developed to study the characteristics of particle charging, including the parameters that affect

the charging mechanism, by using the in-line static mixer charger made of copper. With the application of the on-line tribocharge analyzer developed in this study, it is definitive that the charge measurements can be carried out in an efficient way, and the experimental data for coal, quartz and pyrite samples are unerringly recorded.

2.2 Apparatus and experimental procedure

In trying to study the charging behavior of particles after contact electrification, the charge measuring system is undoubtedly of most particular importance. Many techniques for measuring the charging tendency of particles (Schaefer, et.al., 1994; Gidaspow, et.al., 1987; Lawver and Wright, 1968; Kittaka, et.al., 1979; Secker and Chubb, 1984; Gajewski, et.al., 1987; Mazumder et.al., 1991) were discreetly taken into account. As the result, the “Faraday pail” technique was well chosen as a basis for the new charge-measuring device.

Static charge is normally measured by *induction* and the classic method of measuring the static charge is by use of a “Faraday cage or pail”, coupled to a suitable monitoring circuit. A typical Faraday pail consists of inner and outer cages made of metal. The inner cage is electrically connected to an electrometer while the outer cage is grounded to serve as shield against surrounding electronic interference. Ideally, a Faraday cage should entirely surround the sample whose charge is being measured such as to prevent the measurement being suffered from surrounding noise. However, in practice it is not always necessary to have the charged sample completely surrounded because the sample may only be contacted by the metal connected to an electrometer, and the resulting charge on the sample can then be measured. It is determined that the charge induced on the inner wall of the inner cage is equal in magnitude but opposite in sign to the introduced charge, and a charge of the same magnitude and sign occurs on the outside of the inner cage, or is transferred to the monitoring electronic circuit.

The mechanisms involved in the charge measurement using the Faraday cage are illustrated in Figure 2.1. Let us assume that particles are charged negatively, and consider the

case in which particles touching the wall of the inner cage, as shown in Figure 2.1 (a). The free electrons of the particles will flow from the particle surface to the walls, resulting in a flow of electric current from the Faraday cage to the electrometer. Consider also the case of the negatively charged particles not touching the walls, as depicted in Figure 2.1 (b). In this case, the particles will polarize the inner cage in such a manner that the inner wall is positively charged while the outer wall is negatively charged. The free electrons will flow from the negative charge sites of the inner wall to the electrometer, generating a current. Hence, in both cases, the presence of negatively charged particles will result in a current flowing from the Faraday cage to the electrometer.

In order to facilitate in-situ charge measurement, an on-line tribocharge analyzer has been developed incorporating the Faraday cage mechanism and our in-line static mixer tribocharger. The charge measuring device consists of a copper in-line static mixer, with dimension of 2.22 cm in diameter and 0.15 m. in length, and an outer tube which also made of copper (Figure 2.2). Based on the principle of Faraday cage, the in-line static mixer is electrically connected to an electrometer (Keithly Model-642) by means of a coaxial cable while the outer copper cylinder is grounded to reduce interference from nearby electrostatic fields or charges. Teflon rings were put in between the static mixer and the outer tube at both ends to avoid short circuit.

The entire on-line tribocharge analyzing system constructed for measuring the charge of both coal and mineral matter in this research is shown in Figure 2.3. In a given experiment, a sample was stored in a vacuum oven before being placed on the feed hopper. The sample was subsequently fed into the on-line tribocharge analyzer system by means of a compressed air, which is heated by use of a heating tape before entering the system. An air filter was placed on the top of the sample collection chamber to eliminate the situation of the particles travelling backward. The analyzer is capable of acquiring and digitizing the analog signal by using a data acquisition system when the particles pass through the tribocharger. The Fast Fourier Transformation (FFT) procedure has been applied to the digitized information for noise reduction. Figure 2.4 shows a print out from our preliminary tests on the data acquisition system connected to the on-line tribocharge analyzer.

Five main parameters affecting the charging mechanisms were investigated during this paper. These include air velocity, particle feed rate, particle size, ash content, and temperature effects. The air pressure was maintained at 40 psi during each experiment. Except where varied and stated, otherwise, the system temperature was upheld in the range of 28-30° C for the experiments. At a given experimental condition, the measurement was repeated at least three times to acquire reproducible results.

2.3 Materials

In order to obtain information on the charging mechanisms of both coal and the ash-forming minerals commonly presenting in coal, two different Pittsburgh No.8 coal samples: i.e., a clean coal sample assaying approximately 6.3% ash and a run-of-mine coal assaying approximately 19-22 % ash, quartz, and pyrite were used. The Pittsburgh coal sample was crushed in a jaw crusher and then in a roller mill. The crushed coal samples were pulverized to -40 mesh in a hammer mill and then dry-screened to provide three different size fractions, namely: -40+65, -65+100, and -100+200 mesh. In a different way, a pyrite sample originated from Huanzula, Peru (according to the supplier) was crushed and ground manually by means of the cast iron mortar and pestle, and then dry-screened to obtain the same size fractions.

A commercial quartz sample, obtained from the supplier in two different size fractions (-40+65 and -65+100 mesh), was used for the charge measurements.

2.4 Results and discussion

Preliminary measurements showed that the coal samples acquire a positive charge after contact with copper surface, while ash-forming minerals, such as quartz and pyrite, acquire negative triboelectric charges. These results can be ascribed to the fact that the work function of

copper lies intermediately to those of coal and mineral samples; clearly put, the work function of copper is higher than those of coal samples but lower than those of quartz and pyrite samples. This finding means that the basic requirement for the triboelectrostatic separation (TES) of coal and mineral samples is accordingly satisfied. The experimental verification is shown by some results obtained with the Pittsburgh No. 8 coal sample (which assayed approximately 6.3% ash and 1.6% sulfur) using a bench-scale TES unit (Yoon, et.al., 1996). The result from the test conducted with positive electrode at 40 kV and with the other electrode grounded showed that the product and reject streams were obtained after passing the coal sample into the separator. It appeared that the reject stream (which assayed 8.62% ash and 1.96% sulfur.) was collected on the positive electrode surface. The result after the first pass gave a combustible recovery of 58.6% and 52.4% yield.

The main parameters by which the charging tendency may be affected are discussed under the following segments.

2.4.1 Effect of Air Velocity

Figure 2.5 shows the effect of air velocity on the magnitude of the charge density of samples. The particle feed rate was maintained at 0.2 kg/min in average for all tests. As shown in the figure, an average charge per unit mass of all samples increases with an increasing of air velocity regardless of particle size. This can be described by the fact that an increase in the air velocity cause an increase in the impact velocity of the particles when they impinge on the copper walls and blades of the in-line static mixer charger, which in turn results in better particle-wall contact. This observation is consistent with what have been shown in a literature (Ban, et.al., 1993).

Apparently, the charge density of the coal samples is much higher than that of the quartz and pyrite samples. Also, pyrite sample tends to be more negatively charged than quartz. This finding is in agreement with the previous work done by Finseth et.al. (1993), which shows that the dry triboelectrostatic separation process can remove pyrite better than other ash-forming

minerals. In addition, the results given in this figure show that the charge densities of the particles increase with decreasing particle sizes. Such effect will be discussed later in this paper.

2.4.2 Effect of Particle Feed Rate

The effect of the particle feed rate on the magnitude of the charge density is shown in Figure 2.6. The charge measurements were carried out at an air velocity of 1.9 m/sec. For all samples, an increase in the particle feed rate decreases the magnitude of charge density regardless of particle size. This is due to the fact that, at a given air velocity, the decrease in particle velocity often happens when the population of the particle in the charger is enlarged and the chance of particles hindering each other is elevated. As a result of that, the occurrence that the particles are obstructed in the charger is occasionally experienced at the high particle feed rate.

At a given air velocity, the pyrite and quartz do not exhibit the large difference in their charge densities. It should be noted here that pyrite being a semi-conductor may lose its charge which may have contributed to low charge density of pyrite upon contact with another conductor (Rose-Innes, 1980). In addition, it is obvious that the clean coal sample acquires about 3-4 times higher charge density than both quartz and pyrite samples do. Such finding can also be seen in the effect of air velocity shown in Figure 2.5. This phenomenon may be explained by the fact that both ash-forming minerals have higher mass-to-size ratio, when compared to coal, and this thus causes their lower particle velocities at a given particle size and air velocity.

2.4.3 Effect of Particle Size

The investigations were conducted using Pittsburgh No.8 coal sample (6.27% ash) with a particle feed rate of 0.08 Kg/min and an air velocity of 2.0 m/sec. The results are given in Figure 2.7. Note that the effect of particle size can be clearly seen also in Figure 2.5 and 2.6. Not surprisingly, a decrease in the charge density of the coal sample is observed with increasing mean

particle diameter. This can simply be attributed to the higher surface area-to-mass ratio of the finer particles, creating larger contact area at a given mass.

2.4.4 Effect of Ash Content

Figure 2.8 shows the results of the charge measurements conducted on the Pittsburgh No.8 coal samples with approximately 6% and 20% ash contents. The results show that lower the ash content, the higher the charge density becomes. Consider that the data attained from the charge measurements are the net charge. It is presumably that the charge acquired on ash-forming minerals present in coal may offset the charge density of coal obtained while charging. However, the effect of ash content on the tribocharge density is still far from conclusive. No dependence of the charge density on the ash content can be established in this paper.

2.4.5 Effect of Temperature

Figure 2.9 illustrates the charge densities of the samples obtained from the experiments when the system temperature was varied. The charge measurements were conducted at an air velocity of 1.9 m/sec and at a particle feed rate of 0.2 Kg/min. The results show that the charge densities of clean coal and quartz samples increase with increasing temperature. It is well known that humidity is one of the critical factors in electrostatic separation. Such water adsorbed onto the particle surface may increase the surface electrical conductivity. Accordingly, the charge on particle that originated by contact electrification under humid environment, in most cases, will dissipate rapidly when touched by other particles due to the surface conductivity created by the surface moisture. It may thus be concluded that the increase in temperature in this case has an effect on the charge density in such a way that the surface moisture of these insulator samples be dried away.

By contrast, the charge density of the pyrite sample decreases with increasing temperature. It is well established that pyrite possesses a conducting ability, maybe not as well as a pure metal but certainly not as bad as an insulator. In elementary solid state physics (Omar, 1993), it is pronounced that the conductivity depends on temperature. In this situation, the conductivity is expressed in terms of the microscopic properties pertaining to the conduction electrons. One finds the following expression for the conductivity,

$$\sigma = Ne^2\tau / m^*, \quad [2.1]$$

where N is the concentration of the conduction electrons, τ is called the *relaxation time*, and m^* is the *effective mass* of the electron. It has been seen that the conductivity increases as N increases, because there are more current carriers. From the result of statistical mechanics distribution, the concentration of conduction electrons is found increasing exponentially with temperature [33]. Thus as the temperature is raised, a greater number of electrons is excited and the conductivity become rising accordingly. For this reason, the pyrite sample becomes more conducting with increasing temperature, resulting in a decrease in the charge density. As mentioned earlier, the conductivity yields the charge to leak away from the contact area when two conductors are touched with each other (Rose-Innes, 1980).

2.5 Conclusion

A new practical in-situ charge-measuring device, called “on-line tribocharge analyzer”, has been developed in the present work. It has been confirmed that the on-line tribocharge analyzer can be used to obtain needed information for determining the charging characteristics of fine particles.

The data reported in this paper show that the copper in-line static mixer has given the impressively high magnitude of charge density for both coal and ash-forming mineral (i.e. quartz and pyrite) samples used in the experiments. This suggests that the separation can be

satisfactorily accomplished by using an in-line static-mixer charger for the charging process. However, an appropriate contacting material should also be in consideration.

In this study, the effects of the main parameters on the charging behavior were evaluated: i.e., air velocity, particle feed rate, particle size, ash content, and temperature. Within the observed region, the coal and ash-forming mineral samples exhibited the maximum difference in the charge per unit mass at the highest air velocity and the lowest particle feed rate, regardless of particle size. The particle charge was furthermore found to decrease with an increase in the particle size, according to the results obtained with all samples. For the coal samples, humidity and ash content also contribute to the charge density of the samples. Increasing temperature, however, suggests a relatively little effect within the observed temperature range, as it only drives off surface moisture that causes the charge drainage due to surface conductivity.

In closing, it is obvious that additional work is needed in order to better understand the particle charging mechanism. It is also of interest to further investigate various parameters affecting the tribocharging process. Once the information on charging characteristics is obtained, the separation efficiency of the triboelectrostatic process can be increased.

2.6 References

- Agus, M., Carbini, P., Ciccu, R. and Ghiani, M. (1990). Triboelectric Coal Cleaning and Desulfurization with the Turbocharger Separator. *3th Int. Conf. Proc. and Util. of High Sulfur Coals*. Amsterdam: Elsevier Science Publishers.
- Ban, H., Schaefer, J.L. and Stencel, J.M. (1993). Size and Velocity Effects on Coal Particle Triboelectrification and Separation Efficiency. *Proc. 10th Int. Annu. Pitt. Coal Conf.*, Pittsburgh, USA.
- Blacktin, S.C. and Robinson, H.(1931). *Safety in Mines Research Board Paper*, no. 71. London.

- Carta, M., Carbini, P., Ciccu, R., Del Fa, C., Ghiani, M. and Rossi, G. (1982). Beneficiation Methods for Coal Desulphurization. In A.M. Al Taweel (Ed.), *Proc. CIC Coal Symp. 64th* (pp. 164).
- Finseth D.H., Newby, T. and Elstrodt, R. (1993). Dry Electrostatic Separation of Fine Coal, *5th Int. Conf. Proc. and Util. of High Sulfur Coals*. Amsterdam: Elsevier Science Publishers.
- Gajewski, J.B., Jankowski, Z. and Jodkowski, W. (1987). A New Approach to Electric Charge Measurements. *Electrostatics 1987* (Inst. Phys. Conf. Ser. 85) (pp. 355-360). Bristol, Great Britain: The Institute of Physics.
- Gaudin, A.M. (1971). The Principles of Electrical Processing with Particular Application to Electrostatic Separation. *Miner. Sci. Engng.*, **3**, 46-57.
- Gidaspow, D., Wasan, D.T., Saxena, S., Shih, Y.T., Gupta, R. and Mukherjee, A. (1987). Electrostatic Desulfurization of Coal in Fluidized Beds and Conveyers. *AIChE Symposium* (Series no.255), **83**, 74-85.
- Harper, W.R. (1967). *Contact and Frictional Electrification*. London: Oxford University Press.
- Inculet, I.I., Quigley, R.M. and Filliter, K.B. (1980a). Coal-Clay Triboelectrification. In *Conf. Rec. 1980 15th Annu. Meet. IEEE Ind. Appl. Soc.*
- Inculet, I.I., Quigley, R.M., Bergougnou, M.A., Brown, J.D. and Faurichou, D.K. (1980b). Electrostatic Beneficiation of Hat Creek Coal in the Fluidized State. *Canadian Inst. Mining and Metallurgy Bulletin*, **73**(822), 51-61.
- Inculet, I.I. (1984). *Electrostatic Minerals Separation*. New York: John Wiley and Sons, Inc.

- Kelly, E.G. and Spottiswood, D.J. (1982). *Introduction to Mineral Processing*. New York: John Wiley and Sons, Inc.
- Kelly, E.G. and Spottiswood, D.J. (1989). The Theory of Electrostatic separation: A Review part II. Particle Charging. *Minerals Engineering*, **2**(2), 193-205.
- Kittaka, S., Masui, N. and Murata, Y. (1979). A Method for Measuring The Charging Tendency of Powder in Pneumatic Conveyance through Metal Pipes. *J. Electrostatics*, **6**, 181-190.
- Lawver J.E. and Wright, J.L. (1968). The Design and Calibration of a Faraday Pail for Measuring Charge Density of Mineral Grains, *Trans AIME/SME*, **241**, 445-449.
- Link, T., Killmeyer, R., Elstrodt, R. and Haden, N. (1990). Initial Study of Dry Ultrafine Coal Beneficiation Utilizing Triboelectric Charging with Subsequent Electrostatic Separation, *Project Report*, DOE/PETC/TR90/11 (DE91000943).
- Lockhart, N.C. (1984). Dry Beneficiation of Coal. *Powder Technology*, **40**, 17-42.
- Lowell, J. and Rose-Inns, A.C. (1980). Contact Electrification. *Advanced in Physics*, **29**, 947-1023.
- Mazuda, S., Toragushi, M., Takahashi, T and Haga, K. (1983). Electrostatic Beneficiation on Coal Using a Cyclone-Tribocharger. *IEEE Transactions on Industry Applications*, **IA-19**(5), 789-793.
- Mazumder, M.K., Ware, R.E., Yokoyama, T. Rubin, B. and Kamp, D. (1991). Measurement of Particle Size and Electrostatic Charge Distributions on Toners Using E-SPART Analyzer. *IEEE Trans. Ind. Appl.*, **27**(4), 611-619.

- Nieh, S. and Nguyen, T. (1987). Measurement and Control of Electrostatic Charges on Pulverized Coal in a Pneumatic Pipeline. *Particulate Science and Technology*, **5**, 115-130.
- Omar, M.A. (1993). *Elementary Solid State Physics*. Massachusetts, USA: Addison-Wesley Publishing Company, Inc.
- Ralston, O.C. (1961). *Electrostatic Separation of Mixed Granular Solids*. Amsterdam: Elsevier.
- Rich, S.R. (1986). US Patent 4,627,579.
- Robinson, M. (1969). In H.A. Pohl (Ed.), *Dielectrophoretic and Electrophoretic Deposition*. Cambridge: Electrochem Soc.
- Rose-Innes, A.C. (1980). Contact Charging of Dielectrics. In *Physics of Dielectric Solids 1980* (Inst. Phys. Conf. Ser. 58) (pp. 123-132). Bristol, Great Britain: The Institute of Physics.
- Seanor, D.A. (1972). In K.C. Frisch and A.V. Patsis (Eds.), *Electrical Properties of Polymers*. Westport, Connecticut: Technomic Publication.
- Salanek, W.R., Paton, A. and Clark, D.T. (1976). Double Mass Transfer during Polymer-Polymer Contacts. *J.appl. Phys.*, **47**(1), 144-147.
- Schaefer, J.L., Stencel, J.M. and Ban, H. (1994). Triboelectrostatic Dry Coal Cleaning. *Proc. 11th Int. Annu. Pitt. Coal Conf.*, Pittsburgh, USA.
- Secker, P.E. and Chubb, J.N. (1984). Instrumentation for Electrostatic Measurements. *J. Electrostatics*, **16**, 1-19.

Yoon, R.H. (1991). In J.W. Leonard, III (Ed.), *Coal Preparation*. Baltimore: SME, Port City Press.

Yoon, R.H., Yan, E.S., Luttrell, G.H. and Adel, G.T. (1996). POC-Scale Testing of a Dry Triboelectrostatic Separator for Fine Coal Cleaning. *5th Quarter Technical Progress Report*, DE-AC22-95PC95151.

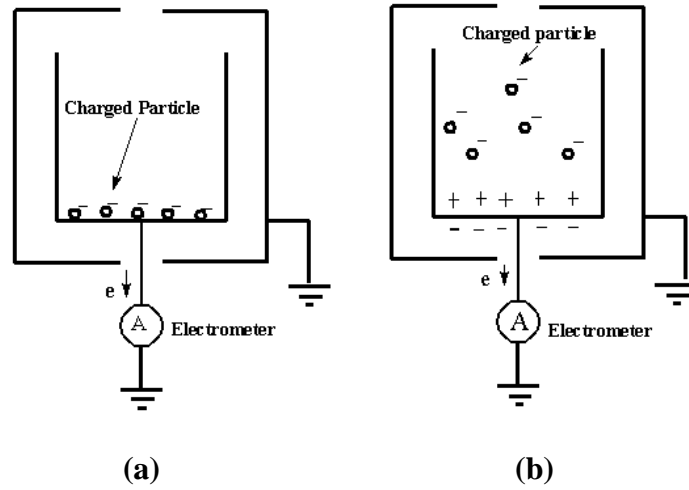

Figure 2.1. Schematic representation of the principle of particle charge measurement using a Faraday cage.

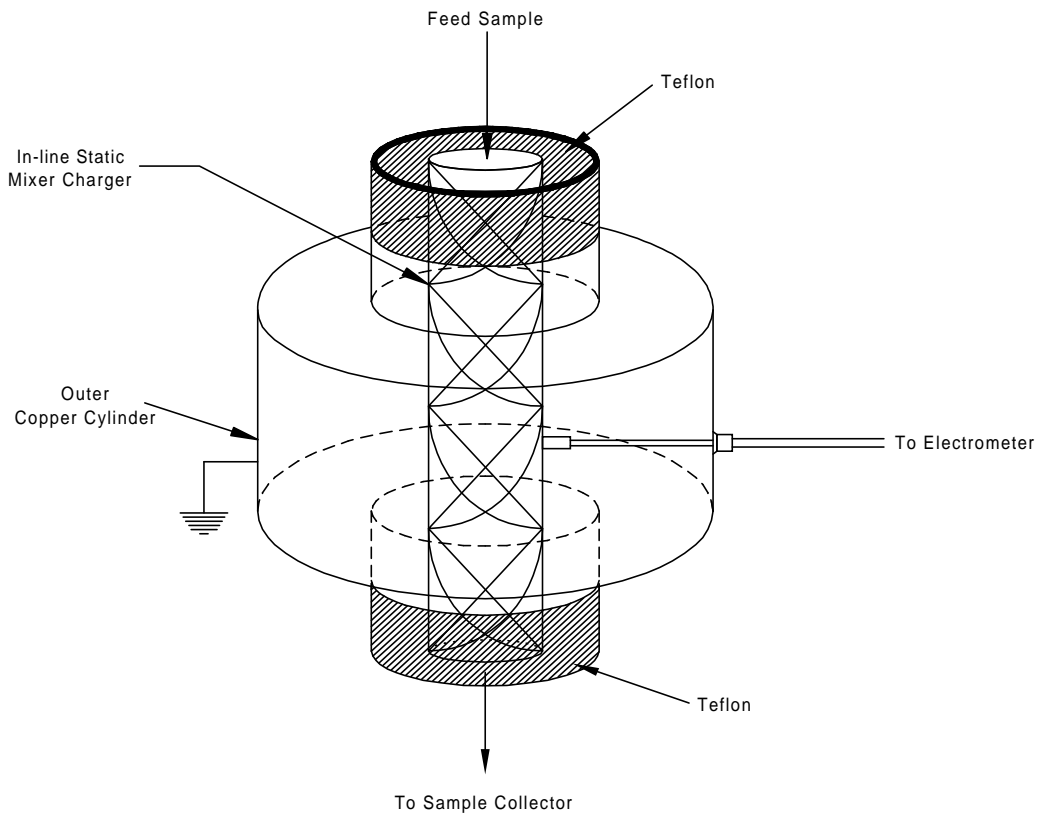

Figure 2.2. The on-line charge measurement device developed for the experiments.

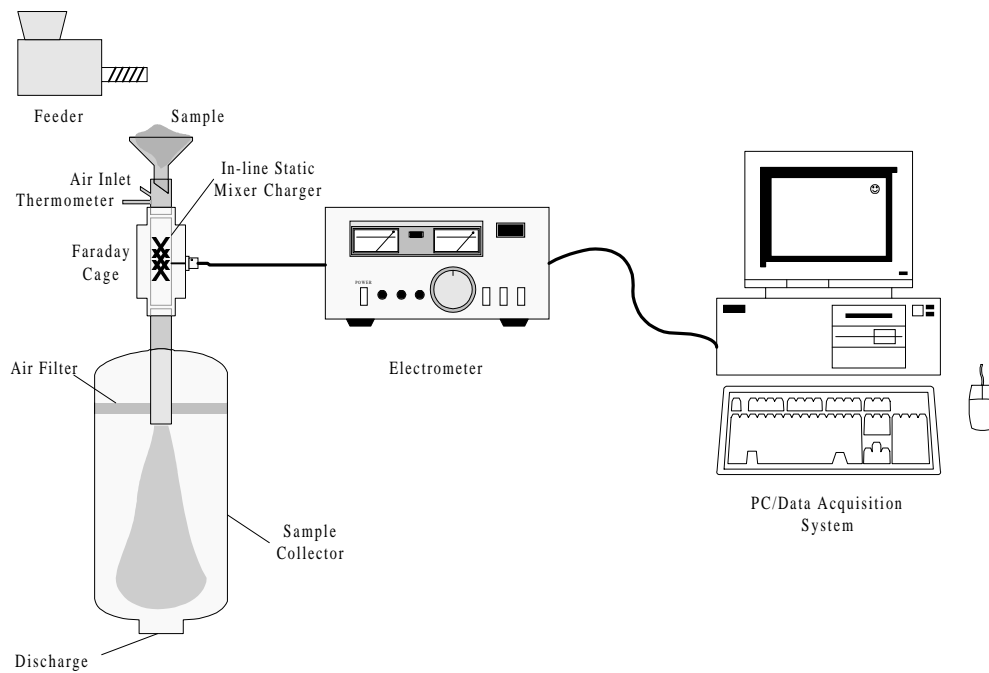

Figure 2.3. Schematic representation of the on-line tribocharge analyzer & the experimental set-up.

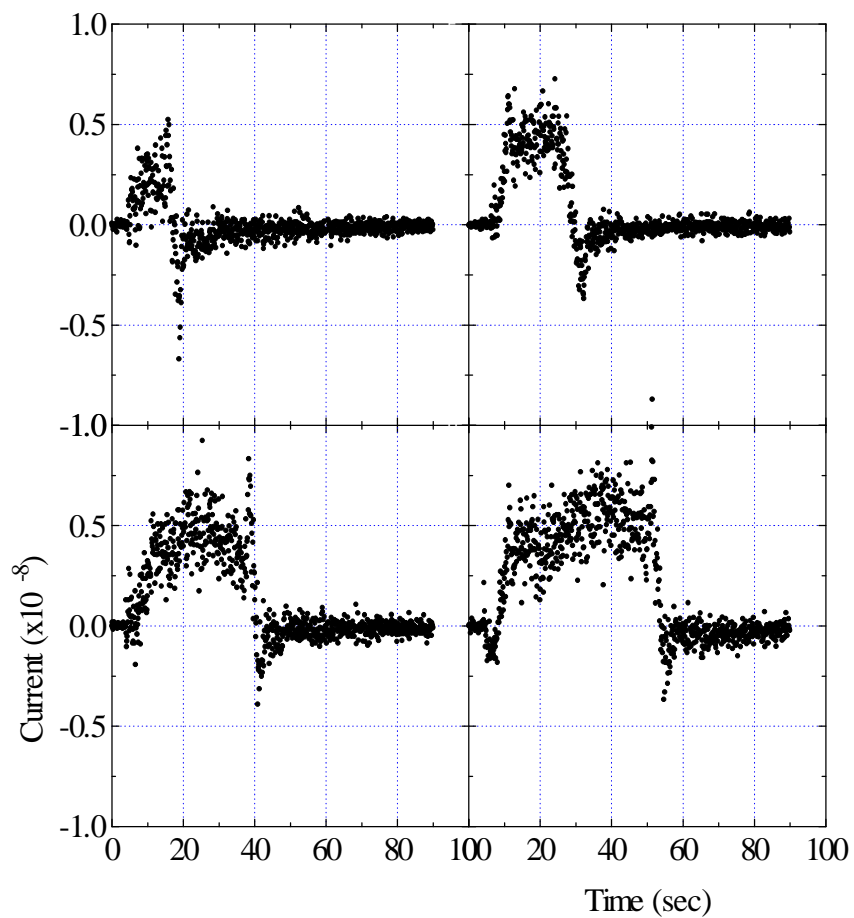

Figure 2.4. A printout from the data acquisition system used in conjunction with the on-line charge- measurement device. The results were obtained with a Pittsburgh No.8 coal sample (-28 x 65 mesh) by varying feed rates.

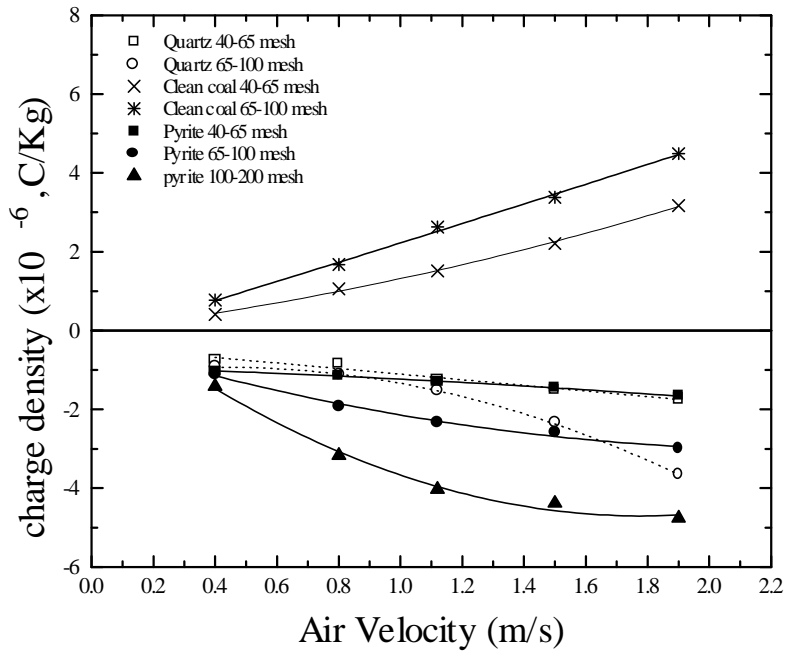

Figure 2.5. The effect of air velocity on charge densities of Pittsburgh No.8 clean coal (6.27% ash), quartz, & pyrite samples. The experiments were carried out at air pressure of 40 psi, particle feed rate of 0.2 Kg/min, & temperature in the range of 28-30 deg.C.

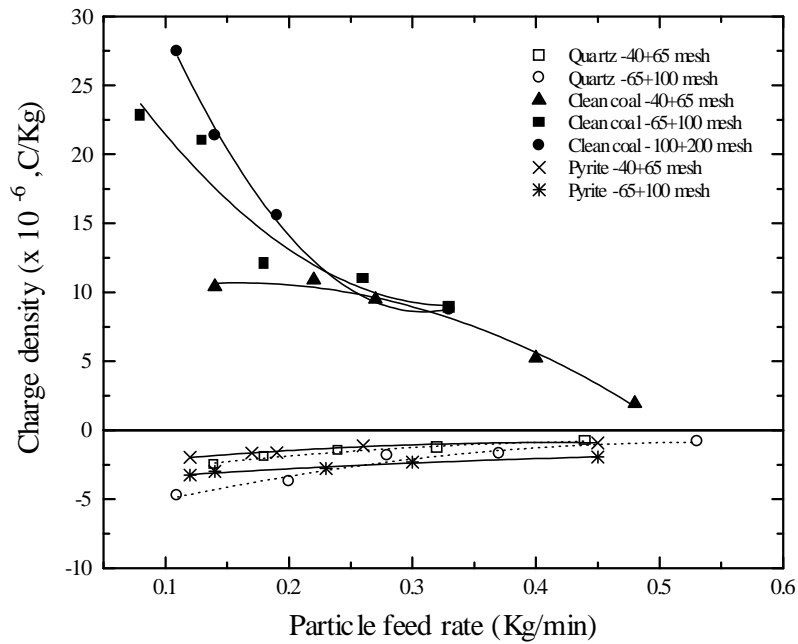

Figure 2.6. The effect of particle feed rate on charge densities of Pittsburgh No.8 clean coal (6.27% ash), quartz, & pyrite samples. The experiments were carried out at air pressure of 40 psi, air velocity of 1.9 m/s, & temperature in the range of 28-30 deg.C.

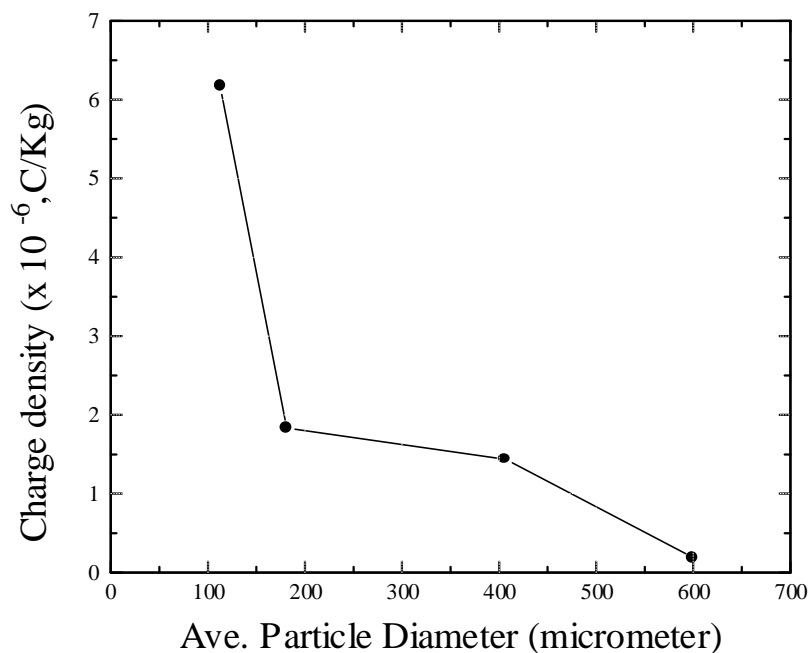

Figure 2.7. The effect of particle size on charge density of a Pittsburgh No.8 coal sample assaying 19-22% ash. The experiments were done at particle feed rate of 0.08 m/s, air velocity of 2.0 m/s, air pressure of 40 psi, & temperature in the range of 28-30 deg.C.

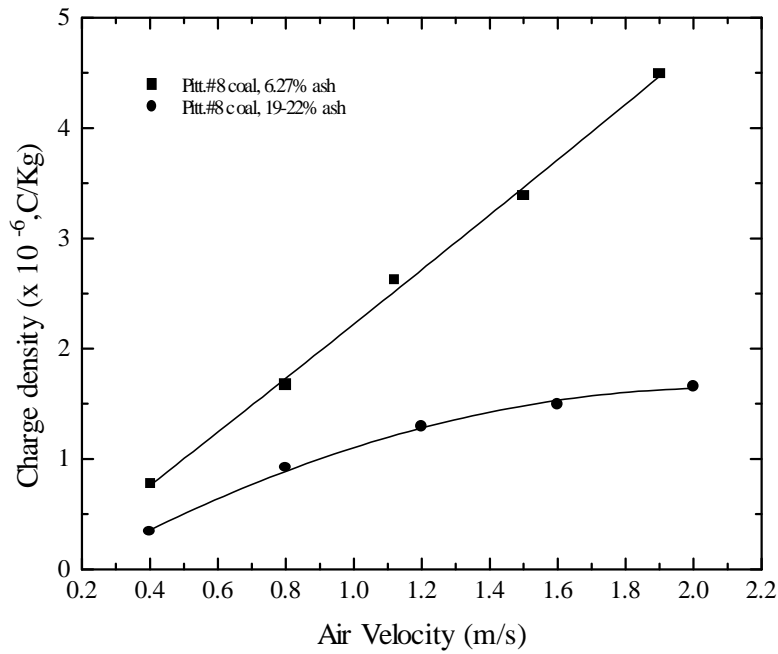

Figure 2.8. Effect of ash content on the charge density of Pittsburgh No.8 coal samples. The experiments were conducted at particle size fraction of -65+100 mesh, particle feed rate of ~0.2 Kg/min, air velocity of 1.9 m/s, air pressure of 40 psi, & temperature in the range of 28-30 deg.C.

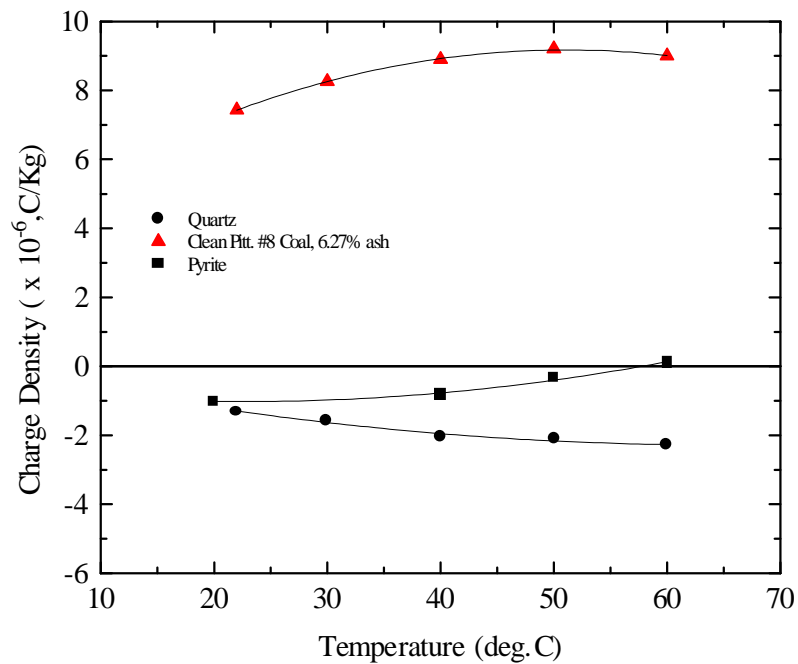

Figure 2.9. Effect of temperature on charge densities of Pittsburgh No.8 clean coal (6.27% ash), quartz, & pyrite samples. The experiments were conducted at the particle size fraction of -65+100 mesh, air velocity of 1.9 m/s, air pressure of 40 psi, particle feed rate of 0.3 Kg/min, & temperature in the range of 28-30 deg.C.