

**DEVELOPMENT AND DEMONSTRATION OF A
PERFORMANCE TEST PROTOCOL FOR RADIANT
FLOOR HEATING SYSTEMS**

Amit Khanna

Thesis submitted to the Faculty of the Virginia Polytechnic Institute and State University
in partial fulfillment of the requirements for the degree of

Master of Science
In
Architecture

Dr. James Jones, Chairman
Prof. Robert Schubert
Dr. Mike Ellis

January 6, 2006
Blacksburg, Virginia

Keywords: radiant heating, radiant floor, radiant panel

DEVELOPMENT AND DEMONSTRATION OF A PERFORMANCE TEST PROTOCOL FOR RADIANT FLOOR HEATING SYSTEMS

Amit Khanna

Abstract

The Radiant Heating markets - especially, the hydronic segment - are growing rapidly in North America due to homeowners' increasing demand for comfort and the steady rise in residential construction. Radiant systems are promising technologies for energy saving in commercial and residential building sectors together with improving occupant thermal comfort. Such a technology is different from the more standard all-air systems and thus can be termed Space Conditioning. However, the thermal performance of radiant systems in buildings has not been fully understood and accounted for. This is primarily due to lack of any standard testing mechanism. The central thrust of this paper is to experimentally investigate questions relating to thermal performance of radiant systems, thus also contribute towards evolving a new standard for testing mechanisms. Products from 12 different radiant floor systems were chosen from the market. Having defined each with similar control parameters such as flow rate, supply water temperature and similar design parameters like size, insulation etc., they are separately tested in a well insulated test setup. Experiments on the time variations for each test floor were performed at supply water temperatures ranging between 100F – 140F with a 10F increment at each stage. Having gathered data through the Data Acquisition System (DAS), the data is analyzed and compared between all systems. The paper concludes by providing recommendations for experimentally testing thermal energy performance, thermal uniformity and thermal stability of radiant floor heating technology.

Acknowledgement

I would like to express my sincere gratitude to Dr. James Jones for his support, guidance and council while conducting this study. I also thank him for entrusting me with this project conducted in collaboration between REHAU and Virginia Tech. I am grateful to him for providing the necessary equipments and software to conduct the research. I thank him for explaining me, among other things, the concepts of data acquisition system and helping me install the experiment set up at Research and Demonstration Facility (RDF). Finally, I thank him for directing my masters study and for the valuable time he spent during weekdays with me.

I would also like to thank Dean Schubert for his continuous encouragement throughout my academic stay at Virginia Tech. I am thankful for his valuable and practical ideas during the construction and working of the experimental test set up of this research. Without his support, my graduate learning would have been incomplete.

I am indebted to Dr. Michael Ellis from the department of mechanical engineering for his great help in the technical aspects of radiant technology (heating and cooling). During the last 2 years, I have benefited immensely from his expertise in HVAC systems and psychrometric analysis. I am also thankful to him for supporting my academic endeavors even at short notice.

I would also like thank Mr. Lance McNevin, unit manager- HP Engineering, REHAU, for his guidance throughout the experiment. Special thanks to Mr. John Kimball, unit manager- Automotive Engineering, REHAU, for his guidance and physical assistance in the building of the test set up. We, at Virginia Tech. appreciate REHAU's financial and equipment assistance in the successful completion of this project.

I am indebted to my friends and graduate students Ross, Leena and Anchi for their invaluable assistance in the construction and working of the experiment. Special thanks to Leena for her immense contribution to the completion of the experiment. I wish her all the best in life. I am thankful to the entire Solar Decathlon 2005 team for always being there to help me mount heavy test floor devices in the test chamber.

I would like to thank my parents for their guidance and support throughout my life. They have guided me through the winding path of life, while giving me enough room to let me make my own mistakes (and hopefully learn from them).

Finally, I would like to thank my fiancé Lakshmi, whose mere presence in my life inspired me during the countless obstacles during this research. I dedicate my work to her.

Abstract.....	i
Acknowledgements.....	iii
Table of Contents.....	v
List of Figures.....	x
List of Tables.....	xiii
List of Graphs.....	xiv

Table of Contents

I. INTRODUCTION ...1

1-1 Background: from Air-Conditioning to Space Conditioning	1
1-2 Impact of Radiant Heating System	2
1-2-1 Thermal Comfort	2
1-2-2 Indoor Environment Quality	3
1-2-3 Energy Savings	4
1-3 Overview of Contemporary Radiant Heating Floor Technology	4
1-3-1 Concrete Slab installation	4
1-3-2 Subfloor installation	5
1-3-3 Staple-Up installation	5
1-3-4 Joist Space installation	6
1-4 Need for Performance Comparison and Testing Protocol	6

II. LITERATURE REVIEW ...8

2-1 Control parameters and Design parameters	9
2-2 Energy Transportation	10
2-2-1 PEX Tubing	10
2-2-1-1 PEXa: Engel (High Pressure Peroxide)	11
2-2-1-2 PEXb: Silane (Moisture Cured)	12
2-2-1-3 PEXc: Electron Beam (Irradiation)	12
2-2-1-4 Performance Standards.....	13
2-3 Heat Transfer	13
2-3-1 Overall Heat Transfer to Test Floor system	14

2-4	Thermal Inertia	14
2-5	Overall of Commercial Radiant Floor Heating Systems	15
2-5-1	WIRSBO- QuickTrak	15
2-5-2	Ultra-Fin	16
2-5-3	Roth	16
2-5-4	Thermalboard	17
2-5-5	Warmboard	17
2-5-6	RAUPANEL Radiant Heating Systems – REHAU	18
III. RESEARCH EMPHASIS ...19		
3-1	Goal	19
3-2	Scope of Research	19
3-3	Objectives	20
IV. METHODOLOGY: concept framework ...21		
4-1	Development of Test Protocol	21
4-1-1	Design Parameters	24
4-1-1-1	Standard Test Set-Up	24
4-1-1-2	Panel Specific Design Parameters	24
4-1-2	Control Parameters	25
4-1-3	Data Acquisition System	25
4-2	Test Protocol	27
4-2-1	Test Set-Up	27
4-2-2	Experimental Run	28
4-3	Demonstration and Implementation of Test Protocol	28
4-3-1	Control and Design Parameters	29
4-3-1-1	Test Chamber	30
4-3-1-2	Test Floor Device.....	32
4-3-1-3	PEX Tubing	33
4-3-1-4	Hot water Circulation	34
4-3-2	Panel-specific Design Parameters	37

4-3-2-1	RAUPANEL 6" (o/c) w/ insulation	38
4-3-2-2	RAUPANEL 6" (o/c) w/o insulation	38
4-3-2-3	RAUPANEL 8" (o/c) w/ insulation.....	39
4-3-2-4	RAUPANEL 8" (o/c) w/o insulation	39
4-3-2-5	Thermalboard 8" (o/c)	40
4-3-2-6	QuickTrak- WIRSBO	40
4-3-2-7	WARMBOARD	41
4-3-2-8	ROTH	41
4-3-2-9	GYPCRETE	42
4-3-2-10	ULTRAFIN	43
4-3-2-11	JOIST SPACE w/o Plates w/ R19 insulation	43
4-3-2-12	JOIST SPACE w/ Plates w/ R19 insulation	44
4-3-3	Data Acquisition System	45
4-3-3-1	Data Logger	45
4-3-3-2	Temperature Sensors	46
4-3-3-3	Flow Sensor	48
4-3-3-4	Infra-red Thermal Imaging Camera	48
V.	FINDINGS ...	49
5-1	Thermal Uniformity	50
5-1-1	RAUPANEL 6" o.c- w/o Insulation	50
5-1-2	RAUPANEL 6" o.c- w/ Insulation	51
5-1-3	RAUPANEL 8" o.c- w/o Insulation	51
5-1-4	RAUPANEL 8" o.c- w/ Insulation	52
5-1-5	THERMALBOARD 8" o.c- w/ Insulation	53
5-1-6	WARMBOARD	53
5-1-7	QUICKTRACK- WIRSBO	54
5-1-8	ROTH 6" o.c- w/ Insulation	55
5-1-9	GYPCRETE w/ Insulation	56
5-1-10	ULTRAFIN - w/ Insulation	57

5-1-11 JOIST SPACE w/o plates w/ Insulation	58
5-1-12 JOIST SPACE w/ plates w/ Insulation	59
5-2 Heat Transfer	60
5-2-1 Overall Heat Transfer to Test Floor system	60
5-3 Thermal Stability	63
5-3-1 RAUPANEL 6" o.c- w/o Insulation	64
5-3-2 RAUPANEL 6" o.c- w/ Insulation	64
5-3-3 RAUPANEL 8" o.c- w/o Insulation	65
5-3-4 RAUPANEL 8" o.c- w/ Insulation	65
5-3-5 THERMALBOARD w/ Insulation	66
5-3-6 WARMBOARD	66
5-3-7 QUICKTRAK	67
5-3-8 ROTH w/ Insulation	67
5-3-9 GYPCRETE	68
5-3-10 ULTRAFIN	68
5-3-11 JOIST SPACE - w/o Plates	69
5-3-12 JOIST SPACE - w/ Plates	69

VI. RESULTS AND DISCUSSIONS ...70

6-1 Hypothesis 1	70
6-2 Hypothesis 2	71
6-3 Hypothesis 3	73

VII. LIMITATIONS AND ASSUMPTIONS ...77

7-1 Strong Convection Component	77
7-2 Inconsistent Design Parameters	78
7-3 Limitations of Thermocouples	78
7-4 Back Losses	79
7-5 Mixing valve	79
7-6 Precision of Control Parameters	79

VIII. RECOMMENDATIONS: Contribution to future Testing Mechanisms ...80

- 8-1 Control Parameters80
 - 8-1-1 Uniformity in Airflow80
 - 8-1-2 Fluid Flow Temperature control81
- 8-2 Design parameters81
 - 8-2-1 Test Chamber Dimensions81
 - 8-2-2 Diffuser/ Grille Locations81
 - 8-2-3 Test Chamber Insulation82
- 8-3 Data Acquisition System82
 - 8-3-1 Thermal Sensors82

REFERENCES...83

- Resume84**

List of Figures

Figure 1-3-1: Concrete Slab Installation [courtesy: RPA]	4
Figure 1-3-2: Subfloor Installation [courtesy: RPA]	5
Figure 1-3-3: Staple-up Installation [courtesy: RPA]	5
Figure 1-3-4: Joist Space Installation [courtesy: RPA]	6
Figure 2-2-1: Cross-linked structure of PEX pipe	11
Figure 2-3: Schematic sketch of radiant heat transfer in a space	13
Figure 2-5-1: QuickTrak Panels	15
Figure 2-5-2: Ultra-fin Installation	16
Figure 2-5-3: Roth Panels	16
Figure 2-5-4: Thermalboard Radiant Floor Installation	17
Figure 2-5-5: Warmboard Installation	17
Figure 2-5-6: RAUPANEL Radiant Floor Installation	18
Figure 4-1a: Schematic Sketch of Experimental Set-up	23
Figure 4-1b: Detailed Layout Supply/ Return Loop and Radiant Panels	26
Figure 4-3-1: Test Set-up	29
Figure 4-3-1-1a: 3-D rendered image of Test Chamber	30
Figure 4-3-1-1b: 3-D hidden image of Test Chamber	30
Figure 4-3-1-1c:3-D wire frame image of Test chamber showing radiant floor tube layout	30
Figure 4-3-1-1d: Test Chamber Construction (1)	31
Figure 4-3-1-1e:Test Chamber Construction (2)	31
Figure 4-3-1-1f: Test Chamber Construction (3)	31
Figure 4-3-1-1g:Test Chamber Construction (4)	31
Figure 4-3-1-2a: Radiant Floor Test Device	32
Figure 4-3-1-2b: Radiant Floor Test Device Construction (1)	32
Figure 4-1-1-2c: Radiant Floor Test Device Construction (2)	32
Figure 4-3-1-3a: Cross-linked structure of PEX pipe [courtesy: REHAU]	33
Figure 4-3-1-3b: RAUPEX in different sizes [courtesy: REHAU-NA]	34

Figure 4-3-1-4a: Hot Water Circulation Loop (front side view)	34
Figure 4-3-1-4b: Hot Water Circulation Loop (inlet-outlet side view)	34
Figure 4-3-1-4c: Mixing Valve	35
Figure 4-3-2-1a: RAUPANEL 6” o.c Construction (1)	38
Figure 4-3-2-1b: RAUPANEL 6” o.c Construction (2)	38
Figure 4-3-2-2a: RAUPANEL 6” o.c w/o insulation Construction (1)	38
Figure 4-3-2-2b: RAUPANEL 6” o.c w/o insulation Construction (2)	38
Figure 4-3-2-3a: RAUPANEL 8” o.c w/ insulation Construction (1)	39
Figure 4-3-2-3b: RAUPANEL 8” o.c w/ insulation Construction (2)	39
Figure 4-3-2-4a RAUPANEL 8” o.c w/o insulation Construction (1)	39
Figure 4-3-2-4b: RAUPANEL 8” o.c w/o insulation Construction (2)	39
Figure 4-3-2-5a: Thermalboard 8” o.c Construction (1)	40
Figure 4-3-2-5b: Thermalboard 8” o.c Construction (2)	40
Figure 4-3-2-6a: QuickTrak 7” o.c Construction (1)	40
Figure 4-3-2-6b: QuickTrak 7” o.c Construction (2)	40
Figure 4-3-2-7a: Warmboard 12” o.c Construction (1)	41
Figure 4-3-2-7b: Warmboard 12” o.c Construction 2)	41
Figure 4-3-2-8a: Roth 6” o.c Construction (1)	41
Figure 4-3-2-8b: Roth 6” o.c Construction (2)	41
Figure 4-3-2-9a: Gypcrete 8” o.c Construction (1)	42
Figure 4-3-2-9b: Gypcrete 8” o.c Construction (2)	42
Figure 4-3-2-9c: Gypcrete 8” o.c Construction (3)	42
Figure 4-3-2-9d: Gypcrete 8” o.c Construction (4)	42
Figure 4-3-2-10a: UltraFin Construction (1)	43
Figure 4-3-2-10b: UltraFin Construction (2)	43
Figure 4-3-2-11a: Joist Space 8” o.c w/o plates Construction (1)	43
Figure 4-3-2-11b: Joist Space 8” o.c w/o plates Construction (2)	43
Figure 4-3-2-12a: Joist Space 8” o.c w/ plates Construction (1)	44
Figure 4-3-2-12b: Joist Space 8” o.c w/ plates Construction (2)	44

Figure 4-3-3-1a: Data-logger DL1	45
Figure 4-3-3-1b: Data-logger DL2	45
Figure 4-3-3-2a: Test Floor sensor layout	46
Figure 4-3-3-2b: Upper Ceiling sensor layout	47
Figure 4-3-3-2c: Lower (underside floor) Ceiling sensor layout	47
Figure 4-3-3-3a: Flow Sensor (1)	48
Figure 4-3-3b: Flow Sensor (2)	48
Figure 4-3-3-4a: HSI 1000 camera	48
Figure 4-3-3-4b: HSIPPC Standard Pocket PC	48
Figure 5-1-1a: I.R image at $T_{sw}= 100$ F.....	50
Figure 5-1-1b: I.R image at $T_{sw}= 120$ F.....	50
Figure 5-1-4a: I.R image at $T_{sw}= 100$ F.....	52
Figure 5-1-4b: I.R image at $T_{sw}= 110$ F.....	52
Figure 5-1-7a: I.R image at $T_{sw}= 100$ F.....	54
Figure 5-1-7b: I.R image at $T_{sw}= 110$ F.....	54
Figure 5-1-7c: I.R image at $T_{sw}= 120$ F.....	54
Figure 5-1-7d: I.R image at $T_{sw}= 130$ F.....	54
Figure 5-1-9a: I.R image at $T_{sw}= 100$ F.....	56
Figure 5-1-9b: I.R image at $T_{sw}= 110$ F.....	56
Figure 5-1-9c: I.R image at $T_{sw}= 120$ F.....	56
Figure 5-1-9d: I.R image at $T_{sw}= 130$ F.....	56
Figure 5-1-10a: I.R image at $T_{sw}= 100$ F.....	57
Figure 5-1-10b: I.R image at $T_{sw}= 110$ F.....	57
Figure 5-1-10c: I.R image at $T_{sw}= 120$ F.....	57
Figure 5-1-10d: I.R image at $T_{sw}= 130$ F.....	57
Figure 5-1-12a: I.R image at $T_{sw}= 100$ F.....	59
Figure 5-1-12b: I.R image at $T_{sw}= 110$ F.....	59
Figure 5-1-12c: I.R image at $T_{sw}= 120$ F.....	59
Figure 5-1-12d: I.R image at $T_{sw}= 130$ F.....	59

List of Tables

Table 2-5-1: QuickTrak Panel Information.....	15
Table 2-5-2: UltraFin Panel Information.....	16
Table 2-5-3: Roth Panel Information.....	16
Table 2-5-4: Thermalboard Panel Information.....	17
Table 2-5-5: Warmboard Panel Information.....	17
Table 2-5-6: RAUPANEL Information.....	18
Table 4-3-2: Design Parameters of Radiant Panel Test Devices.....	37
Table 4-3-3-3: Flow Sensor (Dimensional Specs)	48
Table 4-3-3-4: HSI 1000 Technical Specifications.....	48

List of Graphs

Graph 5-1-1: Surface Temperature Distribution along sensors 3- 9 (RAUPANEL 6” o.c- w/o R13).....	50
Graph 5-1-2: Surface Temperature Distribution along sensors 3- 9 (RAUPANEL 6” o.c- w/ R13).....	51
Graph 5-1-3: Surface Temperature Distribution along sensors 3- 9 (RAUPANEL 8” o.c- w/oR13).....	51
Graph 5-1-4: Surface Temperature Distribution along sensors 3- 9(RAUPANEL 8” o.c- w/ R13)	52
Graph 5-1-5: Surface Temperature Distribution along sensors 3- 9 (RAUPANEL 8” o.c- w/ R13)	53
Graph 5-1-6: Surface Temperature Distribution along sensors 3- 9 (WARMBOARD)...	53
Graph 5-1-7: Surface Temperature Distribution along sensors 3- 9 (QUICKTRAK).....	54
Graph 5-1-8: Surface Temperature Distribution along sensors 3- 9 (ROTH 6” o.c- w/ R13).....	55
Graph 5-1-9: Surface Temperature Distribution along sensors 3-9 (GYPCRETE).....	56
Graph 5-1-10: Surface Temperature Distribution along sensors 3- 9(ULTRAFIN w/ R19).....	57
Graph 5-1-11: Surface Temperature Distribution along sensors 3- 9 (JOIST SPACE w/o PLATES w/ R19).....	58
Graph 5-1-12: Surface Temperature Distribution along sensors 3- 9 (JOIST SPACE w/ PLATES w/ R19)	59
Graph 5-2-1: Overall Heat Transfer Potential Comparison at $T_{sw} = 100F$	60
Graph 5-2-2: Overall Heat Transfer Potential Comparison at $T_{sw} = 110F$	61
Graph 5-2-3: Overall Heat Transfer Potential Comparison at $T_{sw} = 120F$	61
Graph 5-2-4: Overall Heat Transfer Potential Comparison at $T_{sw} = 130F$	62
Graph 5-3-1: Stability Performance (RAUPANEL 6” o.c w/o R13).....	64
Graph 5-3-2: Stability Performance (RAUPANEL 6” o.c w/R13).....	64
Graph 5-3-3: Stability Performance (RAUPANEL 8” o.c w/o R13).....	65

Graph 5-3-4: Stability Performance (RAUPANEL 8" o.c w/R13)	65
Graph 5-3-5: Stability Performance (THERMALBOARD 8" o.c w/R13).....	66
Graph 5-3-6: Stability Performance (WARMBOARD w/R13).....	66
Graph 5-3-7: Stability Performance (QUICKTRAK w/R13).....	67
Graph 5-3-8: Stability Performance (ROTH w/R13).....	67
Graph 5-3-9: Stability Performance (GYPCRETE).....	68
Graph 5-3-10: Stability Performance (ULTRAFIN w/R19).....	68
Graph 5-3-11: Stability Performance (JOIST SPACE w/o R19).....	69
Graph 5-3-12: Stability Performance (JOIST SPACE w/R19)	69
Graph 6-1: Surface Temperature Distribution Comparison at $T_{sw} = 100$ F.....	71
Graph 6-2: Surface Temperature Distribution Comparison at $T_{sw} = 110$ F.....	72
Graph 6-3: Surface Temperature Distribution Comparison at $T_{sw} = 120$ F.....	72
Graph 6-4: Surface Temperature Distribution Comparison at $T_{sw} = 130$ F.....	73
Graph 6-5: Stability Performance Comparison at $T_{sw} = 100$ F.....	74
Graph 6-6: Stability Performance Comparison at $T_{sw} = 110$ F.....	74
Graph 6-7: Stability Performance Comparison at $T_{sw} = 120$ F.....	75
Graph 6-8: Stability Performance Comparison at $T_{sw} = 130$ F.....	75
Graph 7-1: T_{air} variation under T_{sw} ranging between 100F – 140F.....	77

I. Introduction

1-1 Background:

From Air-Conditioning to Space-Conditioning

Radiant technologies, in particular radiant floor heating, are increasingly becoming an integral component of high performance green building design. It is one of the low-temperature heating technologies that are believed to reduce energy consumption and perform efficiently under most building configurations.

In the United States, most homes and offices are equipped with air-conditioning systems that utilize the principle of convection and mechanical ventilation to circulate warm or cooled air indoors with built-in fans. As the technology relies solely on the forced distribution of treated air for maintaining thermal comfort and indoor air quality, it tries to balance the components of outdoor and return air to economize energy consumption by compromising on healthy indoor environment. For all-air systems, problems with relatively high-energy use, high costs, poor indoor air quality, draught and noise, have often initiated explorations for new solutions for heating and cooling of buildings. Low temperature heating and high temperature cooling of buildings are potential solutions for these problems. One such approach involves technologies called radiant heating or cooling. The technology promises opportunities in energy efficiency of moving heat via air vs. water and cost effectiveness, while maintaining a healthy indoor environment. Thus, we move from the concept of Air-conditioning to Space-conditioning.

The Roman hypocaust system, built more than 2000 years ago, consisted of raised floors made of concrete and covered in mosaic tiles. Hot gases from a furnace traveled through the hollow spaces under the raised floors until they were released in the atmosphere through a flue in a wall [1]. Around the same time, the Turks were cooling their dwellings by circulating cold river water through interstices in walls or floors [2].

The Romans model for radiant heating was not adopted throughout the world. One possible explanation could be the cost of the installations in the Roman thermal buildings, as well as in the complexity of their design. Instead, for centuries fireplaces

served as a main source of heat. Around the middle of the 18th century cast-iron stoves became the preferred heating source [3]. Next, the hot water boiler was introduced, together with its system of large pipes through which the hot water was carried. The first known such design is attributed to Sir John Stone, who installed a heating system of pipes in the Bank of England in 1790. From here the design of radiators evolved gradually, the use of water giving way to that of steam, then again to water, this time pumped through thinner pipes. The compact radiators used today were introduced at the beginning of this century.

The modern development of radiant heating started in 1907, when Arthur H. Barker, a British professor, discovered that small hot water pipes embedded in plaster or concrete formed a very efficient heating system [1]. Subsequently, “panel heating” was used in Europe in conventional buildings, on the open terraces of many sanatoriums, and in an open-air roofed pavilion at a British World Fair [3]. In the US, Frank Lloyd Wright installed radiant panel heating in the Johnson Wax Building in 1937. By 1940, “Architectural Record” reported the existence of eight such installations in different types of buildings in the US: four residences, a church, a high school, an office building, and an airplane hangar [3].

1-2 Impact of Radiant Heating System

Relevant to the scope of the research hypothesis, the impact of radiant heating floors is briefly discussed with respect to thermal comfort, indoor air quality and energy consumption.

1-2-1 Thermal Comfort

For thermal balance, ideally 50% of human body is regulated by radiation, 30% by convection and 20% by evaporation (sweat and breathing through the mouth). With an ideally designed conditioning system, the occupant would not know if it is cooling or heating. Radiant heating systems try to achieve this. Unlike conventional forced-air systems, with radiant heating, heat exchange from the floor to the room happens mainly via radiation and convection. Under normal panel surface temperatures, human comfort is achieved through 50% radiation, 30% convection, and 20% evaporation.

Because radiant energy travels through space without heating the air itself but rather is absorbed by objects, hydronic radiant heating systems can separate ventilation from thermal conditioning, providing fresh air and conditioning independent from each other. This results in following observations:

- a) Perceivable comfort is achieved with slightly lower air-temperature.
- b) Because the occupants typically have slightly different temperature preferences, they like to control rooms independently. With primary thermal comfort being achieved through radiation, even in the same room, they could position themselves for greatest comfort.
- c) Radiant heating floors ensure near uniformity of radiance and thus, uniform thermal space-conditioning.

1-2-2 Indoor Environment Quality

According to the USEPA, most people spend up to 90% of their time indoors. Thus indoor air quality becomes crucial for a healthy environment. Ventilation provides fresh air to dilute concentrations of pollutants and to carry them outside. Inadequate ventilation can add problems by allowing moisture and temperature levels to waiver. Since, Radiant heating systems perform only sensible heating; such systems are used in conjunction with a reduced flow ventilation system: when compared to all-air systems. With major sensible heating loads being removed by the radiant cooling panels, the reduced ventilation system primarily aims at maintaining indoor air quality and regulating the latent or moisture load of the space.

If the outside environment is dry, the ventilation system is used to humidify the air to achieve acceptable range (40%-60%) for Relative Humidity [ASHRAE 62]. Since the ventilation system used to maintain the Indoor Air Quality and to regulate the latent load of the space, and not to perform sensible heating, the air flow required is small (NO NOISE-NO DRAFT) relative to conventional heating systems. The best results are usually attained with dedicated ventilation supply with no re-circulation of air. This results in a more hygienic environment when compared to conventional systems.

1-2-3 Energy Savings

The potential for lower energy consumption with radiant-floor heating exists through several mechanisms, including lower thermostat settings, lower-temperature boiler settings, and reduced infiltration.

Basically, an all-air conditioning system needs energy to heat, plus energy to transport treated air to the different spaces in the building and back again. Water has more than four times the capacity to absorb heat that air does. In other words, one kilogram of water can absorb four times more energy than one kilogram of air. Therefore, to transfer the same amount of energy with water, four times less mass needs to be transported as compared to air. Consequentially, since thermal comfort is achieved mainly through radiation, people tend to feel comfortable with the small amount of airflow maintained at lower temperatures than normal.

The second opportunity for energy consumption reduction with radiant-floor heating is through keeping the boiler temperature lower than is necessary with conventional baseboard hot water distribution.

1-3 Overview of Contemporary Radiant Heating Floor Technology

This section elaborates on the major radiant floor heating technologies available in the market. [10]

1-3-1 Concrete Slab Installation

Tubing is embedded in the concrete anywhere from the bottom of the slab to within 2 inches of the surface, depending on the design and installation technique.

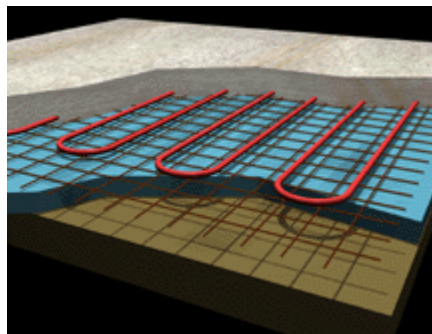

Figure 1-3-1: Concrete Slab Installation [*courtesy: RPA*]

1-3-2 Subfloor Installation

Premanufactured boards with a channel to accept tubing are screwed or nailed to the subflooring. Finished floor such as carpet and pad are placed over the plates while hardwood floors can be nailed directly to the subfloor plates. Cement board is used when tile or stone is to be installed. However, particle board is not recommended as a subfloor.

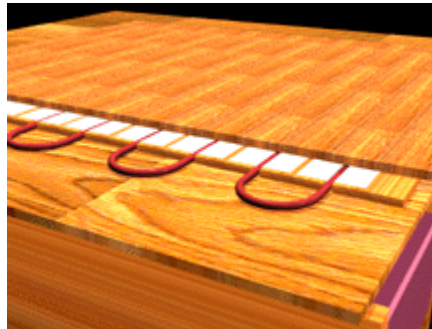

Figure 1-3-2: Subfloor Installation *[courtesy: RPA]*

1-3-3 Staple-Up Installation

Tubing is attached to the underside of the existing subfloor. Aluminum plates can be used to spread the heat evenly under the subfloor. To avoid downward transfer of heat, insulation is placed in the joist space beneath the tubing. Usually, a 2 inch air space is left between the insulation and the bottom of the subfloor. In case aluminum plates are used to significantly cover the underside of the subfloor, the insulation may be pushed up tight against the plates. Proper care must be taken when nailing any floor covering from above.

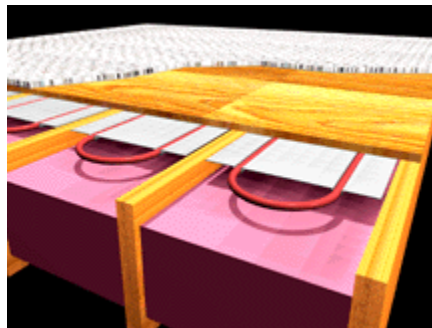

Figure 1-3-3: Staple-up Installation *[courtesy: RPA]*

1-3-4 Joist Space Installation

Tubing is suspended beneath the subfloor in the joist space. Insulation is installed in the joist space beneath the tube with a 2 to 4 inch air space between the top of the insulation and the bottom of the subfloor. The air within this space is heated by the tube which, in turn, heats the underside of the subfloor.

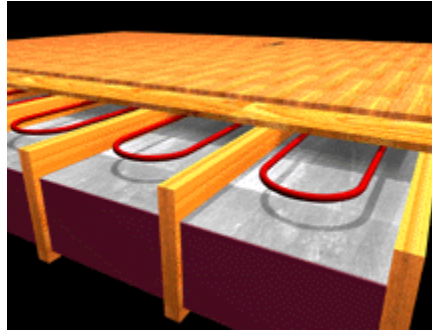

Figure 1-3-4: Joist Space Installation [*courtesy: RPA*]

1-4 Need for Performance Comparison and Testing Protocol

Over the past 10 years, the use of radiant heating has increased significantly. According to the Radiant Panel Association (RPA), sales of radiant heating have jumped by 25%-30% per year since 1991. In 1998, 51.2% of radiant heating was embedded in concrete slabs or below grade (or ground) level, 36.4% was installed on top of subfloors or sandwiched between layers of the wood floor construction, and 11.2% was stapled directly to the subfloor or suspended beneath the floor.

With rapid and diverse growth in the radiant floor heating industry, the current market provides a variety of floor panel options. Each commercial system (as detailed in chapter 2) follows a separate set of design parameters that affect the thermal performance of the radiant floor. Such a wider choice of radiant floor heating systems has necessitated the need for a performance comparison amongst them. Such a comparison can be an effective tool for customers while choosing the system for a particular application.

Most research initiatives investigating radiant floor systems have focused on analyzing thermal comfort models. These have primarily highlighted energy saving and indoor air quality benefits when compared with all-air HVAC systems and thus have been generic. With the industry rapidly diversifying, there exist a variety of radiant floor

systems competing in the market. These systems employed A broader range of design parameters. Such wider range of design parameters employed by the manufacturers has intensified the need for a comprehensive testing mechanism to compare thermal performance of these commercial systems.

While testing mechanisms and future standards can rate the performance of a radiant heating system with panels under given boundary conditions, the efficiency of the same system in a specific, but different, application is always difficult to determine. Since the radiant performance of floor heating panels relies solely on the transient conditions they are applied to, a standard testing mechanism needs to be evolved and adopted to achieve consistency and credibility. This paper aims at developing a standard testing protocol which can be used for thermal comparison for most radiant systems.

II. Literature Review

In the limited research initiatives undertaken investigating radiant floor systems, the focus of most is directed towards analyzing thermal comfort models, energy saving and indoor air quality benefits when compared with all-air HVAC systems. Due to the broad nature of such research, the radiant floor models used have been generic. With the industry rapidly diversifying, there exist a variety of radiant floor systems in the market. A broader range of design parameters employed by these systems has intensified the need for a comprehensive testing mechanism to compare thermal performance of these commercial systems.

Larger credit for the propagation of this technology goes to manufacturers of such systems. They have done a great job in recent years in packaging the various components to simplify the design and installation of radiant-floor systems. The length of tubing required per square foot of floor depends on such variables as tubing diameter, type of radiant-floor system (thick slab, thin slab, no slab), climate, heat load of the building, and type of boiler and controls used. However, while there exists various design manuals, manufacturer-specific installation guides, and software tools for use in designing and sizing radiant-floor heating systems, questions regarding thermal performance and thermal uniformity of such systems are still being explored. Answer to such concerns will directly lead to technological improvements in the design and installation of the radiant system. Since the emphasis of this research is on thermal performance of the radiant system, we limit our study to components directly relating to the transportation and transfer of heat, and not generation of heat.

As an association of manufacturers, distributors, designers, dealers, and installers of radiant panel heating and cooling systems and components, Radiant Panel Association (RPA) is working towards generating better awareness about radiant floor heating systems. It has published guidelines for design and installation of radiant floor systems and recognizes technicians by providing professional certificates. While it is performing commendable work in ‘facilitating communication and cooperation among those interested in the advancement of radiant panel heating and cooling industry’, the

association does not recommend a standard testing mechanism for comparing thermal performance of such systems.

This chapter reviews relevant sources in order to establish a testing mechanism (experimental model and data acquisition strategy).

2-1 Control Parameters and Design Parameters

While testing procedures and future standards can rate the performance of a radiant heating system with panels under given boundary conditions, the efficiency of the same system in a specific, but different, application is difficult to determine. The difficulty arises from the fact that the rated performance greatly depends on the testing procedure.

ASHRAE standard 138-2005 establishes guidelines for laboratory testing of radiant ceiling panels. *'This standard establishes uniform methods of laboratory testing for rating steady-state thermal performance of ceiling panels used for sensible heating or sensible cooling of indoor spaces, or both. The objective is to rate ceiling panels under repeatable conditions'* [4]. Since the standard does not deal directly with radiant floor performance testing, a comparative analysis is avoided. This is due to the change of direction of heat flow and the resulting internal convection patterns. Giving proper considerations, limited co-relation study has guided this research in formulating its testing mechanism. As recommended in the standard, the paper measures thermal performance in terms of:

- *Heat delivered or heat removed by the panel surface as a function of average fluid temperature of the heat transfer medium in the panel, and*
- *The temperatures characterizing the surrounding indoor space* [4].

Primarily, the performance of radiant floor heating panels is affected by two parameters. These can be defined as the *control parameters* and *design parameters*.

During this experiment, control parameters such as supply water temperature, flow-rate and supply air conditions are controlled for each of the radiant panel systems. To achieve credibility and accuracy in thermal comparison of different radiant panels, the

range of supply water temperatures and flow-rate are decided after consultations with professional installation engineers. After consultation with engineers Lance McNevin¹, John Kimball² and Ernie Stevens³, supply water temperature range was decided between 100F-140F (with 10F increment for each set), while the flow rate was maintained at a constant rate of 0.5 GPM. Treated air is supplied at a constant temperature of 70F [5], at a very low airflow rate. This subtle air movement is aimed at avoiding an oven like situation inside, which may unjustifiably affect the outcome of the experiment.

Some *design parameters* may be different depending on the physical characteristics, such as tube spacing, tube diameter, panel specifications, of each radiant floor system. However, for comparison purpose, each panel was covered with ¼” finished commercial plywood and provided with R13 insulation under the floor (except for Joist Space and Ultrafin where we have R19). Again each of the panels is installed in a well insulated chamber to avoid thermal exchange with outside. Physical configurations with respect to panel dimensions are kept constant for each system for consistency of experiment. Consequentially, tube spacing will define total tube length in 8’ x 4’ panel. (Refer chapter IV for details).

2-2 Energy Transportation

It is a well know saying that “a chain is as strong as its weakest link”.

2-2-1 PEX Tubing

In the past, hydronic radiant-floor systems have been using copper piping but most systems today use either rubber or cross-linked polyethylene (PEX) tubing—the latter being by far the most common. This aspect of radiant technology, I believe, has seen a consistent (and common) acceptance of the technological growth and understanding among market leaders. This can be attributed to the large thermal and physical performance benefits of PEX over copper or rubber.

¹ Unit Engineer – HP Engineer, REHAU.

² Unit Manager Automotive Engineering, REHAU.

³ Applications Engineer – HP, REHAU.

”PEX” is an acronym for cross-linked (X) polyethylene (PE). It can be manufactured using one of three commercial cross-linking processes. Under these processes, polyethylene (PE) undergoes a change in molecular structure whereby the polymer chains are chemically linked, or cross-linked (X), with each other to form a three-dimensional network. The result is a thermoset polymer with improved properties, including mechanical stability at elevated temperatures, chemical and environmental stress-crack resistance (ESCR), and reduced creep. A thermoset polymer once formed cannot be separated but non-cross-linked polymer, known as thermoplastic polymer, can be melted and reformed it into some other shape. The number of links between the PE molecules is described as the degree of cross-linking [6, 7].

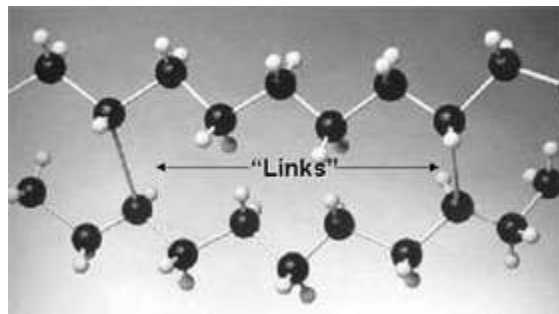

Figure 2-2-1: Cross-linked structure of PEX pipe [courtesy: REHAU]

2-2-1-1 PEXa:Engel (High-pressure peroxide)

The Engel method of cross-linking is a chemical process. Utilizing peroxide, this process is referred to as the "Engel" method, after the chemist who developed it during the 1960's.

Under this procedure, a very small amount of liquid peroxide is added to the base HDPE (high-density polyethylene) pellets, in a controlled mixing chamber at moderate temperature. Next, through a combination of high temperature and pressure developed within the extrusion machine, cross-linking occurs as the resulting compound is melted, and then extruded as cross-linked pipe. With such a small amount of peroxide required to cause cross-linking at this temperature and pressure, the Engel method allows precise control over the degree of cross-linking. [6, 7]

2-2-1-2 PEXb: Silane (Moisture-cured)

The Silane method is a chemical process using one or two step reaction: Sioplas (two-step reaction) and Monosil (one-step reaction).

Dow Corning developed and patented the two step Sioplas process was developed in the late 1960's. Under high temperatures, vinylsilane and peroxide are mixed with HDPE resin, and then packaged in pellet form. A separate operation blends this "graft copolymer" with a specific amount of catalyst master batch, and this combined recipe is fed into the extruder. Pipe is extruded, but not yet cross-linked. The pipe extruded from a Sioplas version resin is cross-linked in a post-extrusion process by exposure to a hot water bath or a steam sauna for a prescribed period of time. The degree of cross-linking typically reaches 65-70%.

The Monosil process is slightly newer than Sioplas, and was introduced in the mid-1970's. In the Monosil (one-step reaction) process, reactive vinylsilane is blended with the HDPE resin during extrusion. Pipe is extruded, but not yet cross-linked. Pipe extruded from a Monosil version resin is cross-linked in a post-extrusion process by exposure to a hot water bath or a steam sauna for a prescribed period of time. The degree of cross-linking typically reaches 65-70%.

2-2-1-3 PEXc: Electron Beam (Irradiation)

Classified as a physical rather than a chemical process, electron beam cross-linking uses high-energy radiation delivered by an electron accelerator (beam). The basic difference between electron beam and the other two chemical processes is that no chemical catalyst is used to initiate the molecular cross-linking action. Instead, a base HDPE resin is simply extruded as pipe, with no special additives, and wound onto large spools.

Spools of pipe are typically transported to an electron beam facility where the pipe is off-spooled and routed under the "beam" of the electron accelerator as a post-extrusion process. As the HDPE pipe is "dosed" with several mega-Rads of radiation, hydrogen atoms are released from adjoining polymer chains, followed by the bonding or "linking" of the open carbon sites. Multiple passes under the beam are required for

consistent cross-linking, whereby 70-75% cross-linking is typical. Side effects of this process are discoloration due to oxidation (from natural white to yellow, unless other pigment is added), and a slightly stiffer product.

2-2-1-4 Performance Standards

All three of these methods can produce PEX pipe that meets the minimum performance requirements of North American standards ASTM F 876 & F 877, NSF Standards 14 & 61, and CSA B 137.5, and all types of PEX pipe are superior to non cross-linked PE pipe [6, 7].

2-3 Heat Transfer

The section of panel has equally spaced pipe layout and the specific heat of the water (the heating medium in the pipe) is higher than that of the thermal mass. So, it can be assumed that the temperature gradient in the direction of the hot water pipes is negligible compared to that in the direction perpendicular to the pipes. Thus, with the panel temperatures known as a result of the experiment, heat transfer analysis was simplified by analyzing in section which is perpendicular to the panel. This will get very close results with minimum amount of calculations. Also, as the hot water pipes are equally spaced in each of the individual radiant panel system, it can be assumed that same unit section is symmetrically repeating [8].

Consequentially, in this study, the heat transfer is analyzed as a two-dimensional unsteady-state in the unit section perpendicular to the pipe.

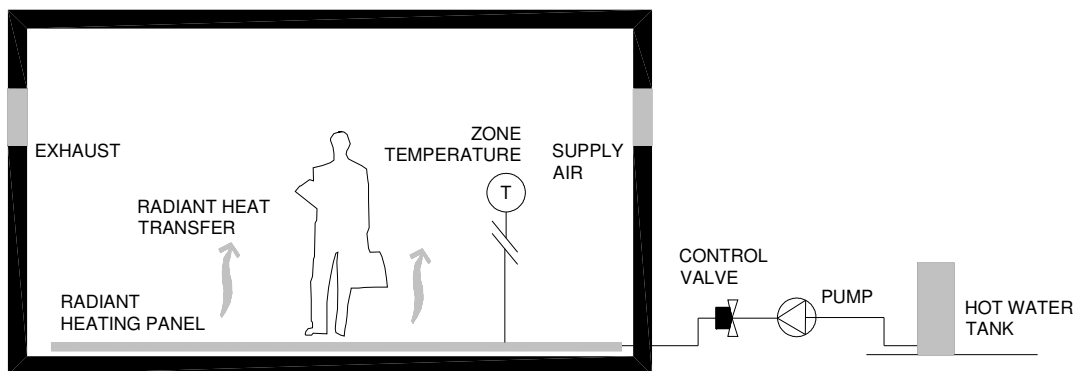

Figure 2-3: Schematic sketch of radiant heat transfer in a space

2-3-1 Overall Heat Transfer to Test Floor system

The opportunity at hand is transporting high temperature water to a given radiant system panel, and then returning relatively cool water back to the primary/ secondary loop. The underlying thermodynamics are simple: *the flow rate between the mechanical room and manifold station is inversely proportional to the temperature drop between the supply and return piping* [9].

$$Q_{\text{loss}} = K \times f \times (\Delta T_{\text{water}}) \quad (1)$$

f = required water flow rate (in gpm)

k = a constant based on the fluid and temperature range. The value of k can be found using Formula 1a.

Q_{loss} = Heat transport Rate (in Btu/ hr)

ΔT_{water} = $T_{\text{sw}} - T_{\text{rw}}$ (in deg. F)

T_{sw} = Supply Water Temperature (in deg. F)

T_{rw} = Return Water Temperature (in deg. F)

$$k = 8.02 \times d \times c \quad (1a)$$

Where:

d = density of fluid at average system temperature (in lb/ft³)

c = specific heat of fluid at average system temperature (in Btu/lb/degrees F)

For Water k=495 at 10 F, k=490 at 140 F, k= 487 at 170 F.

2-4 Thermal Inertia

Thermal inertia can be described as the effect of the thermal energy stored in the mass of the floor due to earlier heat flow through it. This phenomenon can have an impact on the data gathered and may unduly influence thermal performance of a radiant system.

To avoid thermal inertia, following considerations have been made:

- Experiments were run between supply temperatures of 100 F and 140 F in the increasing order. This ensures a gradual transfer of heat energy from water to the floor and eventually to the space.
- Due to limitations in the equipments installed in the test set-up, the supply water temperature had occasional variations. A few minutes increase in the supply water temperature could provide additional thermal energy to the floor and have an impact for duration even after the supply temperature has been restored to controlled temperatures. To avoid this, data in and around such unacceptable values is ignored.

2-5 Overview of Commercial Radiant Floor Heating Systems

This section provides an overview of the major radiant heating floor systems present in the market.

Design parameters for each system may be different depending on the physical characteristics, such as tube spacing, tube diameter, panel specifications, of each radiant floor system. Parameters such as panel make, panel size, tube spacing and tube thickness directly affect the heat transfer characteristic of the radiant floor. This chapter elaborates on the panel design parameters of the systems.

2-5-1 WIRSBO- QuickTrak



Figure 2-5-1: QuickTrak Panels

Panel Make	Panel Size	PEX thickness	Tube Spacing
Wood, Aluminum	7"x48"x1/2"	5/16"	7"

Table 2-5-1: QuickTrak Panel Information

2-5-2 ULTRA-FIN



Figure 2-5-2: Ultra-fin Installation

Panel Make	Panel Size	PEX thickness	Tube Spacing
Aluminum fins – no panel	N/A	5/8" OD	24"-36"

Table 2-5-2: UltraFin Panel Information

2-5-3 ROTH



Figure 2-5-3: Roth Panels

Panel Make	Panel Size	PEX thickness	Tube Spacing
Aluminum & EPS insulation	24"x48", 16"x24"	3/8", 1/2", 5/8"	6", 8", 12"

Table 2-5-3: Roth Panel Information

2-5-4 THERMALBOARD



Figure 2-5-4: Thermalboard Radiant Floor Installation

Panel Make	Panel Size	PEX thickness	Tube Spacing
MDF, Aluminum	16"x48"	3/8" ID	8"

Table 2-5-4: Thermalboard Panel Information

2-5-5 WARMBOARD



Figure 2-5-5: Warmboard Installation

Panel Make	Panel Size	PEX thickness	Tube Spacing
Plywood, Aluminum	48"x96"	1/2"	12"

Table 2-5-5: Warmboard Panel Information

2-5-6 RAUPANEL Radiant Heating Systems – REHAU



Figure 2-5-6: RAUPANEL Radiant Floor Installation

Panel Make	Panel Size	PEX thickness	Tube Spacing
Extruded Aluminum	6"x72"x0.625"	3/8"	6", 8"
	8"x48"x0.625"		

Table 2-5-6: RAUPANEL Information

The overview of the panel design parameters shows two primary panel-makes: wood and aluminum. The conducting and non-conducting nature of radiant panels may affect the performance of the radiant floor. As can be seen, the tube spacing may range between 6" – 12". This forms the basis of our hypothesis as described in chapter 3.

III. Research Emphasis

3-1 Goal

The central thrust of this research is to develop and demonstrate a new performance test protocol for radiant floor systems. The lack of any standard testing mechanism has been an obstacle for wider acceptability of the radiant floor systems in the U.S. The proposed research initiative undertaken by the College of Architecture and Urban Studies at Virginia Polytechnic Institute and State University (Virginia Tech) in collaboration with REHAU Inc. will eventually aid towards credible market awareness encouraging the application of radiant heating technology.

The paper evaluates each radiant floor system for thermal uniformity and energy performance by recording the surface readings along the cross section of the panel during each experimental run and measuring energy flow into the floor panel based on supply and return fluid temperatures

The experiment is performed on 4'x8' test floors installed inside an adiabatic test chamber (size: 4'x8'x8'). Data is gathered from thermal sensors placed on the test floor, the upper ceiling and the lower ceiling which were specifically built for the project. Applying similar physical configurations to 12 different radiant floor systems, test data is collected for supply water temperatures ranging between 100F and 140F and under constant flow rate of 0.5gpm.

3-2 Scope of Research

The thesis concentrates on evaluating the thermal performance affected by the physical configurations of different radiant floor heating systems. The paper focuses on aspects of thermal uniformity, thermal stability and energy performance.

Thermal Uniformity: Thermal uniformity is measured as the distribution of surface temperatures along the cross-section of test floor device.

Thermal Stability: Thermal stability of a radiant heating panel is defined as the measure of fluctuation in temperature readings at each sensor location.

Energy Performance: Measure of energy flow into the floor panel based on supply and return water fluid temperatures.

It is beyond the scope of this research to investigate efficient heat generation methods; rather it focuses on current technological capacities to discharge energy (heat) within an indoor space.

3-3 Objectives

The principal objectives of this study are: to cull a variety of thermal data from the experimental set-up for different radiant floor heating systems in the market and analyze them to evaluate thermal performance. This study will use experimental results to analyze the system for thermal uniformity, energy performance, and also comment on the construction details of the radiant system.

- To develop a step by step test protocol for evaluating performance mandates thermal uniformity, thermal stability, and energy performance.
- To apply new test protocol to test the following hypothesis for selected radiant floor systems.

Hypothesis 1: Radiant systems with conducting surface achieve higher surface temperatures with same supply water temperatures and consequentially higher heat transfer to the space, when compared with systems having non-conducting panel surface.

Hypothesis 2: Radiant systems with metallic (aluminum) panel surface have more uniform thermal distribution over panel surface compared to systems with non-conducting make.

Hypothesis 3: A thermally stable system shows better energy performance based on supply and return fluid temperature readings.

IV. Methodology: *concept framework*

The methodology adopted in this research follows a 2 step approach. The first step is aimed at analyzing the different parameters affecting the panel performance and to develop a testing protocol for evaluating thermal performance of test floor devices. The second step involves implementation of the developed protocol on testing radiant floor panels.

4-1 Development of Test Protocol

A standard Test Protocol is developed to investigate thermal performance mandates of radiant floor heating systems: *thermal uniformity, thermal stability, and energy performance*.

Thermal Uniformity: As defined earlier in chapter 3, thermal uniformity of a radiant heating panel is analyzed by measuring the distribution of surface temperature across the test floor. The temperature readings across the test floor device are analyzed to measure the spread of surface temperatures achieved by the floor.

Thermal Stability: As defined earlier in chapter 3, thermal stability of a radiant heating panel is defined as the measure of fluctuation in temperature readings at each sensor location. Statistical analysis is applied to the collected data to evaluate the fluctuations in surface temperature reached by the radiant panel.

Energy Performance: Energy performance can be defined as the measure of energy flowing into the floor panel based on supply and return water fluid temperatures. The panel design parameters specifications for each test floor directly impacts the energy absorption that occurs within the test floor.

This chapter elaborates on the parameters affecting the above mentioned performance mandates resulting in a step by step test protocol. Careful control over these parameters is necessary for developing a standard testing mechanism.

Broadly, the experiment involves supplying test radiant floor panels with hot water at controlled temperatures and flow rate, and recording temperature readings at different locations within the test set up. The test floor is built and installed in an

adiabatic test chamber. As shown in the Figure 4-1a, the test floor is placed in the test chamber with spaces above and below it. This is designed to simulate above floor space and lower level space. 30 thermal sensors were distributed on the test floor, on the upper ceiling and on the lower ceiling. Thus a variety of data is collected showcasing a comprehensive heat transfer scenario. In addition to the thermal sensors, an electronic flow sensor was also placed in the path of the water flow, thus helping in the control of flow rate at desired value.

Primarily, the performance of radiant floor heating panels is affected by two parameters. These can be defined as the control parameters and design parameters. Thus, the concept framework while developing the testing protocol for evaluating thermal performance of radiant floor panels follows a 3-way approach: Control Parameters, Design Parameters and Data Acquisition System (DAS). These form the guidelines for testing protocol adopted in this research.

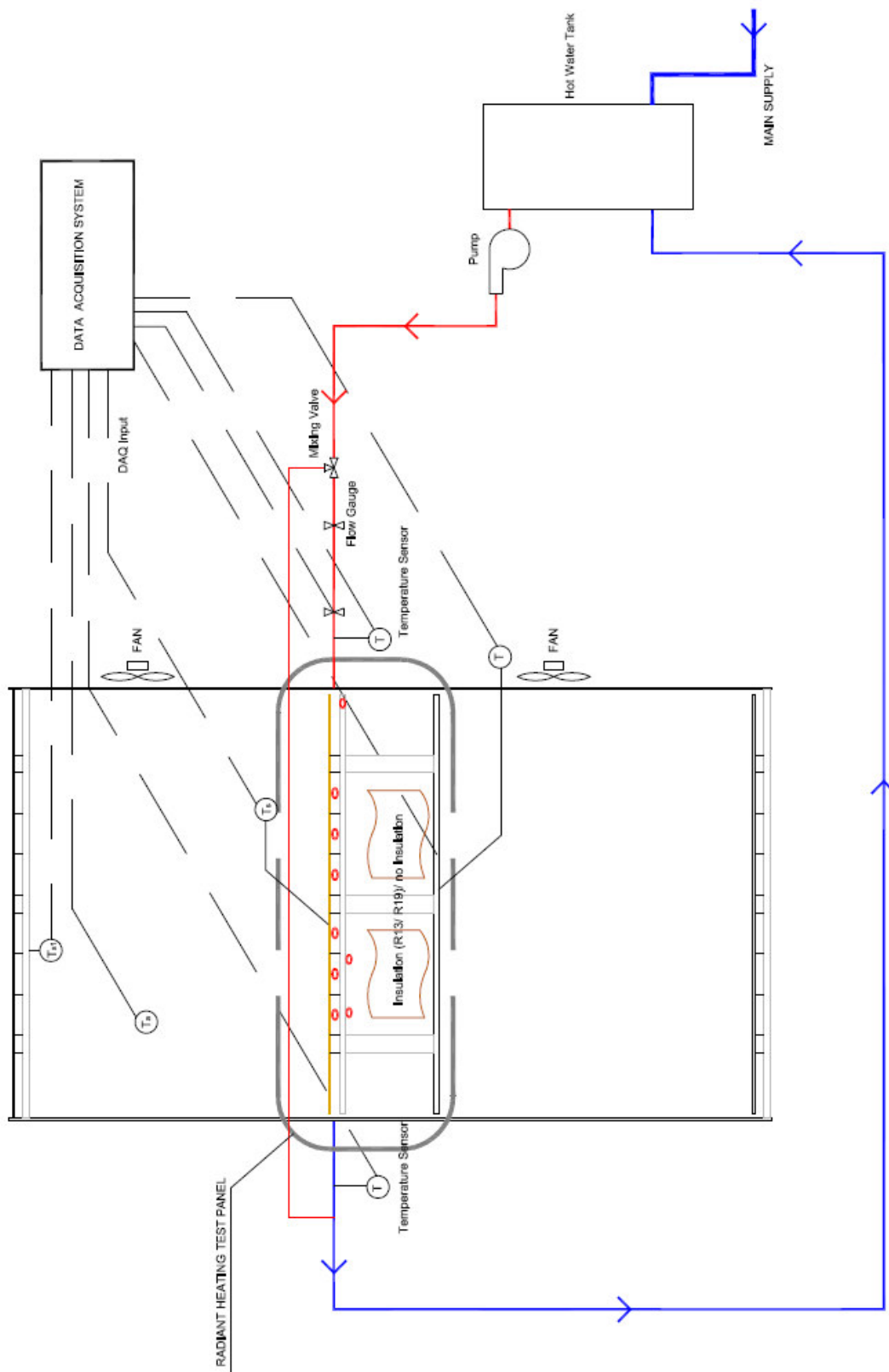

Figure 4-1a: Schematic Sketch of Experimental Set-up

4-1-1 Design Parameters

Design parameters are analyzed under two categorized: Standard Test Set-Up, and Panel Specific Design parameters.

4-1-1-1 Standard Test Set-Up

The test floor is built and installed in an adiabatic test chamber. The test floor is placed in the test chamber with spaces above and below it. This is designed to simulate above floor space and lower level space.

Test Chamber Dimensions- Test chamber dimensions must be decided by considering the range of panel dimensions of the test floors under investigations. It could be decided on the basis of the largest panel dimension amongst the test samples.

Test Chamber Insulation- Test chamber must be well insulated to avoid any thermal interaction with the surrounding environment.

Test Floor Device- Test floor device must be constructed following normal construction practices. Residential installations are the largest application of radiant floor heating. Following wood construction practices, joist space floor can be constructed for the experiment.

Test Floor Device Insulation- Normal installations have an insulation of R13 under radiant floors to prevent back losses. This practice must be followed in the experiment with the exceptions of Joist Space and UltraFin installations which must have an insulation of R19. This is due to the fact that these systems are in joist space and thus require additional insulation to prevent back losses.

PEX tubing- Currently all of the systems use PEX tubing for heat transfer. However, while it is mandatory to use PEX tubing while experimenting on the thermal performance of the radiant floors, tube sizing may be different depending on panel specifications.

4-1-1-2 Panel Specific Design Parameters

Tube Spacing- Each radiant panel requires specific tube spacing. Most systems use a range of tube spacing which is recommended as per the requirements of the application. Since tube spacing and length determine the heat transfer to the space, it is suggested that the comparison be done for the area of application.

Tube Thickness- Panel specifications for each system determine PEX tube size. The experiment uses PEX tube sizes of 5/16", 3/8", and 1/2" depending on specific panel requirements.

Panel Make- Panel makes in today's market vary widely for each system. Most systems however are made of wood panels or aluminum sheets. RAUPANEL is made of extruded aluminum sections.

4-1-2 Control Parameters

Hot Water Supply- Supply water temperature is the most significant parameter which directly affecting the thermal performance of the radiant floor panel. In order to have consistency in approach, supply water temperatures are realized before the start of the experiment. These temperatures must consider the standard temperatures delivered during commercial installation followed by each system. For this study, we adopted a range of 100F – 140F supply water temperatures with an interval of 10F for each experiment set.

Fluid Flow rate – Flow rate must remain constant for each system during the experiment. The size of application decides the flow rate.

Minimal Uniform Airflow- The test chamber must be supplied by a minimal uniform air movement at 70F is continuously supplied through the chamber. The volumetric flow of air is decided as per the size of the test chamber.

4-1-3 Data Acquisition System

Thermal sensors must be distributed on the test floor, on the upper ceiling and on the lower ceiling. Thus a variety of data is collected showcasing a comprehensive heat transfer scenario. In addition to the thermal sensors, an electronic flow sensor shall be placed in the path of the water flow, thus helping in the control of flow rate at desired value.

Thermal readings at each minute must be recorded to study fluctuations in performance. The experimenter may choose any data acquisition system to record these readings without compromising on the precision and with proper calibration.

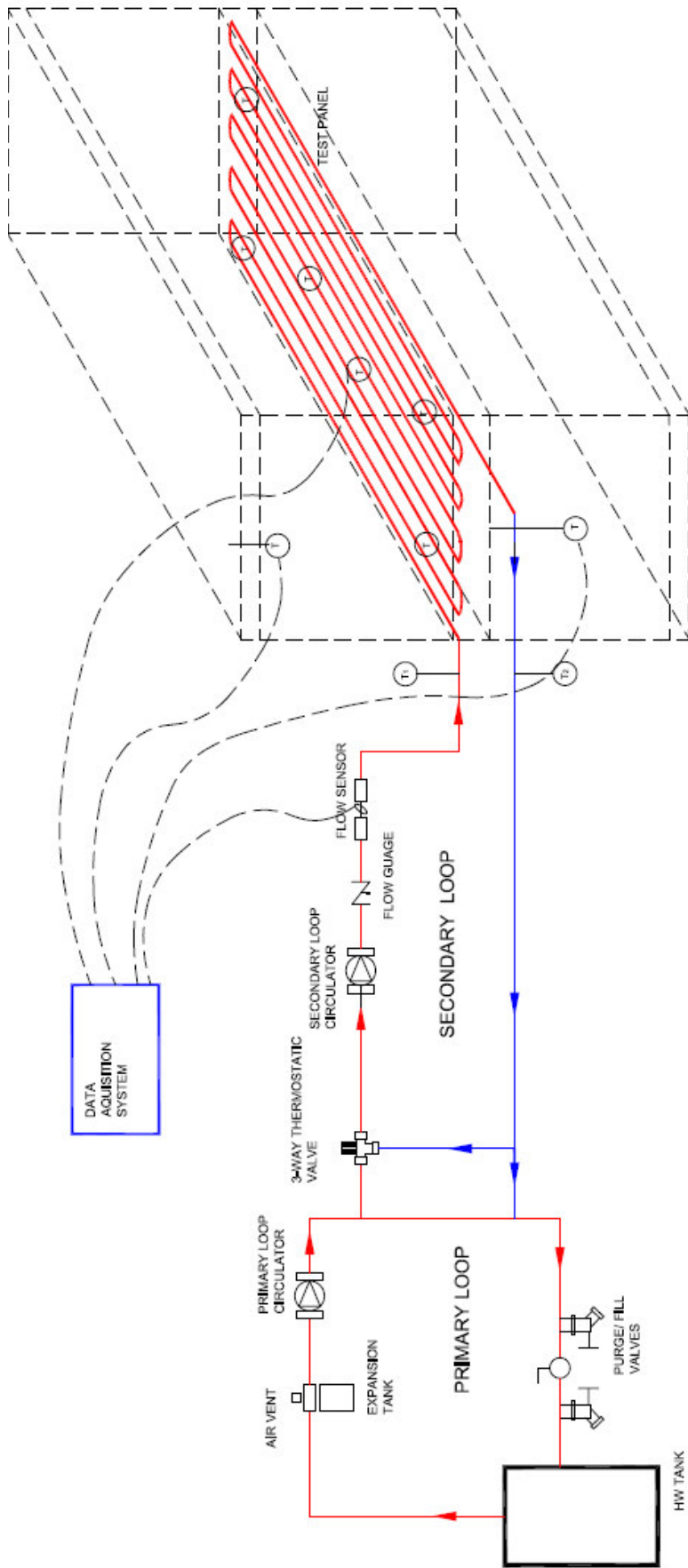

DETAILED LAYOUT SUPPLY/ RETURN LOOP and RADIANT PANELS

Figure 4-1b: Detailed Layout Supply/ Return Loop and Radiant Panels

4-2 Test Protocol

Having constructed the test set-up, the testing protocol must be adopted to perform the experiment. This chapter provides a step by step approach for conducting the experiment.

4-2-1 Test Set-Up

Step 1: Fabricate the sample floor panel on the floor testing device as per the manufacturer's data and mount it in the test chamber.

Step 2: Lay down the PEX tube into the panel as per the manufacturer's instructions.

Step 3: Connect the PEX tube to the hot water circulation loop at the supply and return locations.

Step 4: Lay down the finished ¼" thick plywood on the test panel.

Step 5: Place the temperature sensors on:

- the floor covering (1/4" plywood),
- the upper ceiling surface, and
- the underside of the floor test device.

Step 6: Place temperature sensor hanging 1' from the above ceiling.

Step 7: Place an electronic flow sensor (pulse) in the supply/ return side of the hot water circulation loop.

Step 8: Connect all the sensors described in steps 5, 6, 7 to the data logger following appropriate instructions.

Step 9: Program data logger to record data every minute.

Step 10: Connect flexible air supply ducts to the supply diffusers in the upper and lower sections of the test chamber.

4-2-2 Experimental Run

Step 1: Provide hot water to the panel tubing at supply temperature 100F at 0.5 GPM.

Step 2: Record minute by minute data from all sensors for 90 minutes after an initial run duration of half an hour so that the system achieves initial stability.

Step 3: After 1hr into the experiment, open the chamber and take thermal snaps of the panel.

Step 4: Repeat the steps 1, 2, 3 for supply water temperatures of 110F, 120F, and 130F.

4-3 Demonstration and Implementation of Test Protocol

This section elaborates on the implementation of the test protocol, comparing 12 different commercial radiant floor heating systems, as developed in the previous section.

Broadly, the experiment involved supplying test radiant floor panels with hot water at controlled temperatures and flow rate, and recording temperature readings at different locations within the test set up. The test floor is built and installed in an adiabatic test chamber. As shown in the Figure 4-1, the test floor device is placed in the test chamber with spaces above and below it. This is designed to simulate above floor space and lower level space. 30 copper-constantan thermal sensors were distributed on the test floor, on the upper ceiling and on the lower ceiling. Thus a variety of data is collected showcasing a comprehensive heat transfer scenario. In addition to the thermal sensors, an electronic flow sensor was also placed in the path of the water flow, thus helping in the control of flow rate at desired value.

During this experiment, supply water temperature, flow-rate and supply air conditions are controlled for each of the radiant panel system.

4-3-1 Control and Design Parameters



Figure 4-3-1: Test Set-up

Hot water from portable HW tank (detailed later in this chapter) supplies water at temperature up to a maximum of 150F. The supply water temperature is controlled using mixing valve located at the supply side junction of the primary and secondary loop to achieve the desired temperature ranging between 100F and 140F at increments of 10F. Each experiment is carefully run by varying the supply water temperature from low to high. This is done to avoid any contribution of thermal capacitance effect.

To prevent overheating the test chamber with resulting discrepancies in temperature readings, minimal airflow at 70F is continuously flown through the chamber. This is done by passing conditioned air from the 1.5 ton air-condition at 10% volumetric flow rate through a louvered diffuser (4"x4") on one side and exhausting the same from the grille on the other side of the chamber. The diffuser and grille are located at both levels (above and below) of the test floor.

While each experiment is run between 90 to 120 minutes, the first 15 minutes at each test run is considered for providing stability to the test. Data during this time, though recorded, is not analyzed so as to avoid inconsistency in data.

An infra-red thermal camera is used to visually record during experiments. These, along with recorded sensor data, assist in evaluating thermal uniformity of the system.

Test floor samples (as discussed in detail later in this chapter) from 12 different radiant systems were built and tested. These systems were chosen in consultations with corporate sponsors REHAU primarily on the basis of their competitive presence in the market.

The parameters adopted for the test set-up are elaborated in this chapter.

4-3-1-1 Test Chamber

A near adiabatic test chamber of size 4'x8'x8' was constructed at the Research and Demonstration Facility (RDF) at Virginia Tech. Even though the test chamber was located in a conditioned environment, it was wrapped on all sides with a cumulative R17 insulation to avoid any thermal interaction with the surroundings and to provide a controlled testing environment inside the chamber.

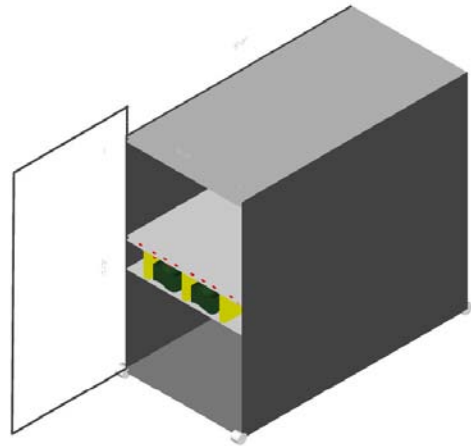

Figure 4-3-1-1a:
3-D rendered image of Test Chamber

As shown in Figures 4-3-1-1a, b, c; the test floor is positioned in the middle of the chamber with 3' high space above and below it.

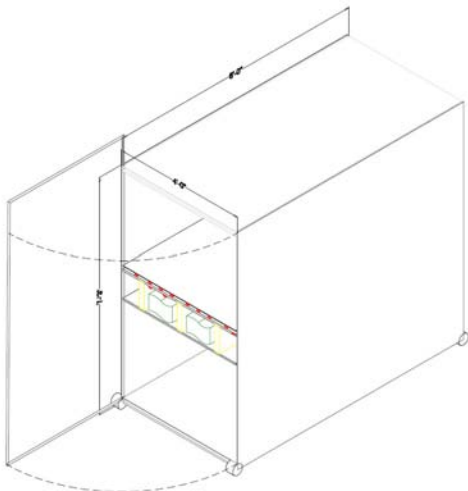

Figure 4-3-1-1b:
3-D hidden image of Test Chamber

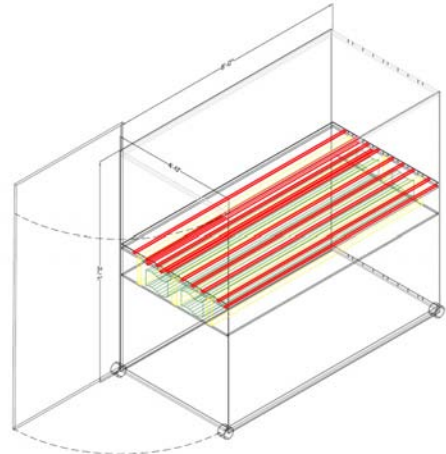

Figure 4-3-1-1c:
3-D wire frame image of Test chamber showing radiant floor tube layout



Figure 4-3-1-1d:
Test Chamber Construction (1)



Figure 4-3-1-1e:
Test Chamber Construction (2)



Figure 4-3-1-1f:
Test Chamber Construction (3)



Figure 4-3-1-1g:
Test Chamber Construction (4)

4-3-1-2 Test Floor Device

Design parameters for each system panel may be different. However, for comparison purpose, each panel was covered with 1/4" finished commercial plywood and provided with R13 insulation under the floor (except for joist space where we have R19). Each system panel possess sparate design parameters such as tube size, tube spacing, and panel specifications. Physical configurations with respect to panel dimensions are kept constant for each system for consistency of experiment.

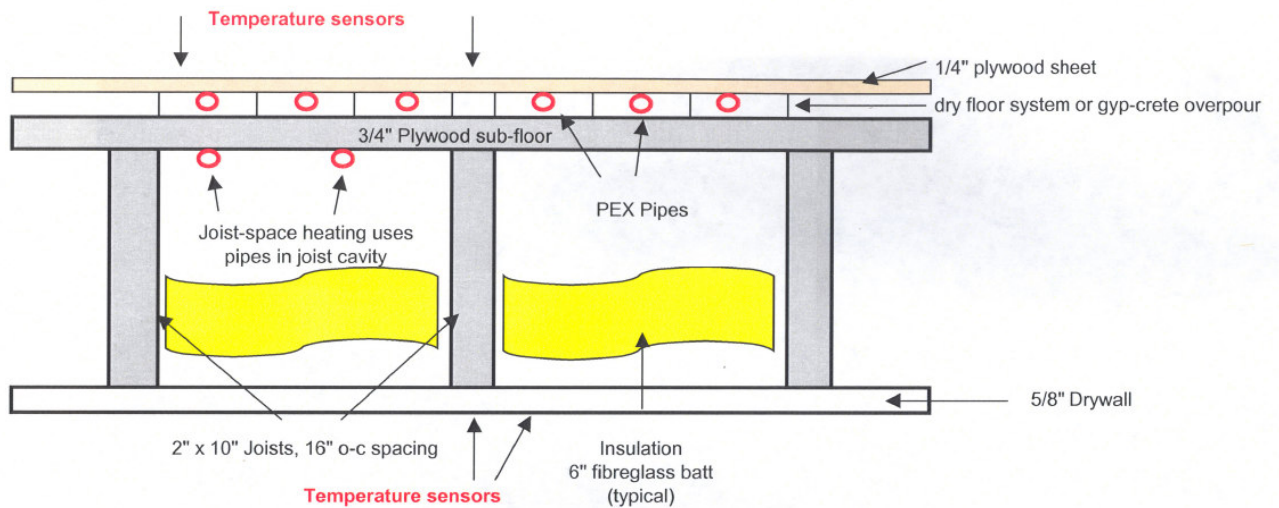

Figure 4-3-1-2a: Radiant Floor Test Device



Figure 4-3-1-2b:
Radiant Floor Test Device
Construction (1)



Figure 4-3-1-2c:
Radiant Floor Test Device
Construction (2)

Insulation of R13 as visible in figure 4-3-1-2c is placed in the floor test device.

4-3-1-3 PEX Tubing (5/16", 3/8", 1/2")

Currently, nearly all radiant floor heating systems in the market use PEX pipe. This is due to considerable advantages this material has over previous heat transfer materials such as copper, rubber etc. The test uses RAUPEX for all radiant systems except QuickTrak.

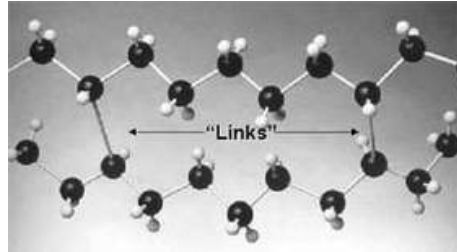

Figure 4-3-1-3a: Cross-linked structure of PEX pipe [courtesy: REHAU]

Properties:

RAUPEX has been subjected to long-term hydrostatic testing by CSA and has a listing with PPI (Plastic Pipe Institute) according to TR-3/99. It has the following continuous use ratings [5]:

- 80 psi at 200°F (550 kPa at 93.3°C)
- 100 psi at 180°F (690 kPa at 82.2°C)
- 160 psi at 73.4°F (1105 kPa at 23°C)

Quality Assurance Standards- All RAUPEX pipes are produced in ISO 9001 certified manufacturing facilities.

Thermal Properties- the strong cross-linking bonds in RAUPEX, prevent it from melting in the same way as other polymers. The full working range of RAUPEX is -184°F to 248°F (-120°C to 120°C).

Chemical Resistance- RAUPEX resists conventional solvents, detergents, antifreeze agents and corrosion inhibitors. Even at high temperatures, RAUPEX resists hydrous solutions of salts, acids and alkali.

Freeze Resistance- RAUPEX pipe will expand when frozen, rather than cracking or splitting.



Figure 4-3-1-3b: RAUPEX in different sizes [courtesy: REHAU-NA]

This research uses 3 sizes (5/16", 3/8", 1/2") of PEX tubing during the experiment as per the specifications of respective test radiant floor. [Refer Chapter 1-3 for detail]

4-3-1-4 Hot Water Circulation

Since the objective of the experiment was to test the thermal performance of the radiant floor systems, the hot water circulation loops were designed to be simple in operation. It involved primary and secondary circulation loops which are both individually powered by 110 VAC pumps.



Figure 4-3-1-4a:
Hot Water Circulation Loop (front side view)



Figure 4-3-1-4b:
Hot Water Circulation Loop (inlet-outlet side view)

Primary Loop: The primary loop circulated extreme hot water from HW tank and includes the expansion tank and the air vent to remove excess air gaps in the flow.

- **Hot Water Tank-** 40 gal. hot water tank with temperature range of 90F -150F is used in the experiment.
- **Potable Hot Water Expansion Tank (PLT-5)-** 2.1 Gal. tank with a maximum pressure of 150 p.s.i and maximum temperature of 160F is used in the experiment.
- **Circulation Pump-** the experiment uses 110 VAC 3-speed pumps with standard on/off switches to control pumps. (UPS 15- 58F/FC Circulator).

Secondary Loop: The hot water is then mixed with return water to achieve the desired supply temperatures for the radiant test floor. This forms the secondary loop. This loop included supply/ return water temperature sensors and a flow sensors connected to the Data Acquisition System (DAS).

- **Mixing valve-** the experiment uses a 3-way thermostatic mixing valve.



Figure 4-3-1-4c: Mixing Valve

While it is simple in installation and blends supply and return water to provide fairly accurate output temperature, it does have some limitations in its applicability:

- ✓ Manual output controls- Since supplying water at controlled temperature forms the basis of this experiment, the experimenter has to keep a watch on the mixing all through the duration of experiment.
- ✓ Not static in output temperature- the supply temperature out of the mixing valve keeps changing depending on the slight variations in the two input streams. Thus it becomes too cold or too warm more often.
- ✓ Limited flow capacity.

- **Circulation Pump-** the experiment uses 110 VAC 3-speed pumps with std on/ off switches to control pumps.
- **Flow meter-** A manual flow meter helps in controlling flow rate as per the readings provided by the pulse-generating flow sensor (discussed later in this chapter). The control, though manual posed no problems during experiment. Once set at the beginning of the experiment, the flow rate remains constant throughout the experiment.

4-3-2 Panel-specific Design Parameters

Each system may follow separate design parameters. These parameters are generally dictated by individual specifications and panel characteristics of the radiant system. However, for comparison purpose, each panel was covered with 1/4" finished commercial plywood and provided with R13 insulation under the floor (except for joist space where we have R19). This section of chapter four documents each individual set-up. Photographs are included to augment the tables wherever necessary.

Radiant Floor System	Panel Make	Panel Size	PEX thickness	Tube Spacing	Insulation	Subfloor Covering	Tube Length
Rehau 6 in (w/ R13 insulation)	Extruded Aluminum	6"x48"	3/8"	6"	R13	1/4" Commercial plywood	80'
Rehau 6 in (w/o insulation)	Extruded Aluminum	6"x48"	3/8"	6"	-	1/4" Commercial plywood	80'
Rehau 8 in (w/ R13 insulation)	Extruded Aluminum, wood	6"x48" Al (+2" x 48" wood stripes)	3/8"	8"	R13	1/4" Commercial plywood	66'
Rehau 8 in (w/o insulation)	Extruded Aluminum, wood	6"x48" Al (+2" x 48" wood stripes)	3/8"	8"	-	1/4" Commercial plywood	66'
Thermal Board 8 w/ Insul	MDF, Aluminum	16"x48"	3/8"	8"	R13	1/4" commercial plywood	66'
Warmboard	Plywood, Aluminum	48"x96"	1/2 "	12"	R13	1/4 " commercial plywood	42'
Quicktrak	Wood, Aluminum	7"x48"x1/2"	5/16"	7"	R13	1/4" Commercial Plywood	66'
Roth w/ 6in Insulation	Aluminum & EPS insulation	24"x48"	3/8"	6"	R13	1/4" Commercial Plywood	80'
Gypcrete	Concrete mass	4' x 8'	3/8 "	8"	R13	-	66'
Ultrafin	Aluminum fins – no panel	N/A	5/8"	2'	R19	3/4 " plywood	
Joist space (without plates)	No panel	4' x 8'	1/2 "	8"	R19	3/4 " plywood	66'
Joist space (with plates)	Aluminum Plates, No panel	4' x 8'	1/2 "	8"	R19	3/4 " plywood	66'

Table 4-3-2: Design Parameters of Radiant Panel Test Devices

4-3-2-1 RAUPANEL 6" (o/c) w/ insulation

Panel Make	Panel Size	PEX thickness	Tube Spacing	Insulation	Subfloor Covering	Tube Length
Extruded Aluminum	6"x48"	3/8" ID	6"	R13	1/4" Commercial plywood	80'



Figure 4-3-2-1a: RAUPANEL 6" o.c Construction (1)



Figure 4-3-2-1b: RAUPANEL 6" o.c Construction (2)

4-3-2-2 RAUPANEL 6" (o/c) w/o insulation

Panel Make	Panel Size	PEX thickness	Tube Spacing	Insulation	Subfloor Covering	Tube Length
Extruded Aluminum	6"x48"	3/8" ID	6"	-	1/4" Commercial plywood	80'



Figure 4-3-2-2a: RAUPANEL 6" o.c w/o insulation Construction (1)



Figure 4-3-2-2b: RAUPANEL 6" o.c w/o insulation Construction (2)

4-3-2-3 RAUPANEL 8" (o/c) w/ insulation

Panel Make	Panel Size	PEX thickness	Tube Spacing	Insulation	Subfloor Covering	Tube Length
Extruded Aluminum, wood	6"x48" Al (+2" x 48" wood stripes)	3/8" ID	8"	R13	1/4" Commercial plywood	66'



Figure 4-3-2-3a: RAUPANEL 8" o.c w/ insulation Construction (1)



Figure 4-3-2-3b: RAUPANEL 8" o.c w/ insulation Construction (2)

4-3-2-4 RAUPANEL 8" (o/c) w/o insulation

Panel Make	Panel Size	PEX thickness	Tube Spacing	Insulation	Subfloor Covering	Tube Length
Extruded Aluminum, wood	6"x48" Al (+2" x 48" wood stripes)	3/8" ID	8"	-	1/4" Commercial plywood	66'



Figure 4-3-2-4a: RAUPANEL 8" o.c w/o insulation Construction (1)



Figure 4-3-2-4b: RAUPANEL 8" o.c w/o insulation Construction (2)

4-3-2-5 Thermalboard 8" (o/c)

Panel Make	Panel Size	PEX thickness	Tube Spacing	Insulation	Subfloor Covering	Tube Length
MDF, Aluminum	16"x48"	3/8" ID	8"	R13	1/4" commercial plywood	66'



Figure 4-3-2-5a: Thermalboard 8" o.c Construction (1)

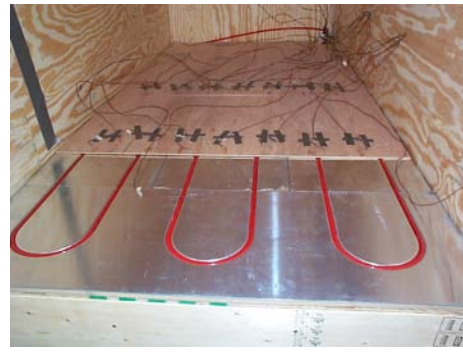

Figure 4-3-2-5b: Thermalboard 8" o.c Construction (2)

4-3-2-6 QuickTrak- WIRSBO

Panel Make	Panel Size	PEX thickness	Subfloor Covering	Tube Spacing	Insulation	Tube Length
Wood, Aluminum	7"x48"x1/2"	5/16"	1/4" Commercial Plywood	7"	R13	66'



Figure 4-3-2-6a: QuickTrak 7" o.c Construction (1)



Figure 4-3-2-6b: QuickTrak 7" o.c Construction (2)

4-3-2-7 WARMBOARD

Panel Make	Panel Size	PEX thickness	Tube Spacing	Sub-floor Covering	Insulation	Tube Length
Plywood, Aluminum	48"x96"	1/2"	12"	1/4" commercial plywood	R13	42'



Figure 4-3-2-7a: Warmboard 12" o.c Construction (1)



Figure 4-3-2-7b: Warmboard 12" o.c Construction (2)

4-3-2-8 ROTH

Panel Make	Panel Size	PEX thickness	Tube Spacing	Sub-floor Covering	Insulation	Tube Length
Aluminum & EPS insulation	24"x48"	3/8"	6"	1/4" Commercial Plywood	R13	80'



Figure 4-3-2-8a: Roth 6" o.c Construction (1)



Figure 4-3-2-8b: Roth 6" o.c Construction (2)

4-3-2-9 GYPCRETE

Panel Make	Panel Size	PEX thickness	Sub-floor Covering	Tube Spacing	Insulation	Tube Length
Concrete mass	4' x 8'	3/8 "	-	8"	R13	66'

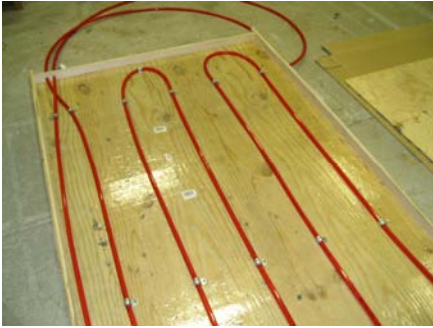

Figure 4-3-2-9a: Gypcrete 8" o.c Construction (1)



Figure 4-3-2-9b: Gypcrete 8" o.c Construction (2)



Figure 4-3-2-9c: Gypcrete 8" o.c Construction (3)



Figure 4-3-2-9d: Gypcrete 8" o.c Construction (4)

4-3-2-10 ULTRAFIN

Panel Make	Panel Size	PEX thickness	Subfloor Covering	Tube Spacing	Insulation	Tube Length
Aluminum fins – no panel	N/A	5/8" OD	-	2'	R19	



Figure 4-3-2-10a: UltraFin Construction (1)



Figure 4-3-2-10b: UltraFin Construction (2)

4-3-2-11 JOIST SPACE w/o Plates w/ R19 insulation

Panel Make	Panel Size	PEX thickness	Sub-floor Covering	Tube Spacing	Insulation	Tube Length
No panel	4' x 8'	1/2"	3/4 " plywood	8"	R19	66'



Figure 4-3-2-11a: Joist Space 8" o.c w/o plates Construction (1)



Figure 4-3-2-11b: Joist Space 8" o.c w/o plates Construction (2)

4-3-2-12 JOIST SPACE w/ Plates w/ R19 insulation

Panel Make	Panel Size	PEX thickness	Sub-floor Covering	Tube Spacing	Insulation	Tube Length
Aluminum Plates, No panel	4' x 8'	1/2"	3/4" plywood	8"	R19	66'



Figure 4-3-2-12a: Joist Space 8" o.c w/ plates Construction (1)



Figure 4-3-2-12b: Joist Space 8" o.c w/ plates Construction (2)

4-3-3 Data Acquisition System

The data acquisition forms an equally important task while performing the experiments. A well crafted experiment could be ruined if the data is not gathered with desired precision and repeatability. Staying within budgetary constraints, this research uses a variety of equipment to capture the results of the experiment.

4-3-3-1 Data logger

Two 21 X Microloggers from Campbell Scientific, Inc were used to record data. Two signals are received from each sensor every minute. Input from the copper-constantan thermocouples and voltage from the fluid flow sensor were wired to the data loggers as single ended inputs. Each sensor reading is measured every five seconds. Each sensor is recorded as two values; one being the average of the five second readings for each one minute interval of the test, and the second being the instantaneous reading also at one minute intervals.

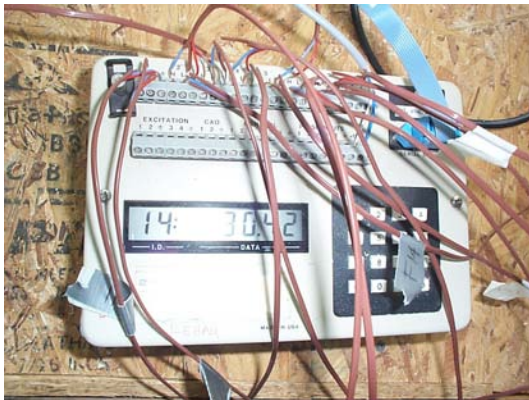

Figure 4-3-3-1a: Data-logger DL1



Figure 4-3-3-1b: Data-logger DL2

The 21X is powered by 8 alkaline “D” cells and has only the power switch on the base. The 16 character keyboard is used to enter programs, commands and data. These can be viewed on the 8-digit display (LCD).

The 9-pin serial I/O port provides connection to data storage peripherals, the SM 192/ 716 Storage Module.

4-3-3-2 Temperature Sensors

Eighteen copper-constantan thermocouples (spaced 6" o.c) are laid on floor (sensors 1/D1 – 2/D2) while five thermocouples (1.5' o.c) are located each on the upper ceiling (sensors 3/D2 – 7/D2) and lower ceiling (sensors 9/D2 – 13/D2), measuring surface temperature distribution. One sensor is hung 6" below the ceiling measuring air temperature. Two thermal sensors are located inside a sensor well at the inlet and the outlet of the PEX tubing, measuring the supply (sensor 14/D) and return (15/D2) water temperatures.

Test Floor Sensors- The sensors on the test floor device are laid across along two cross-sections. The first cross section is about 2' from the outer front edge of the test floor while the second one is along the central cross-section of the test floor (each spaced 6" o.c). This layout provides us with a better understanding of the uniformity of the systems panel and range of surface temperatures achieved along the wider section of the panel. Apart from these sensors, 4 other sensors are located on the four corners of the floor.

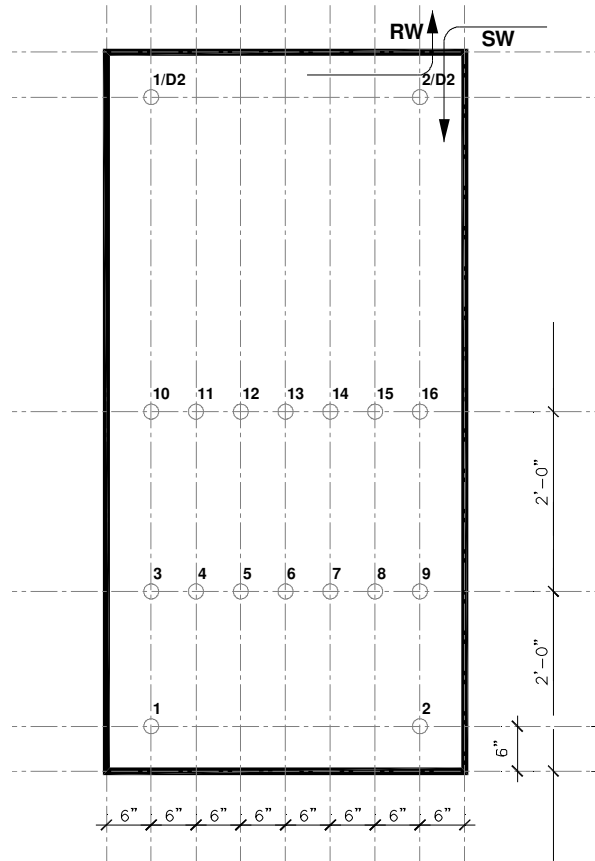
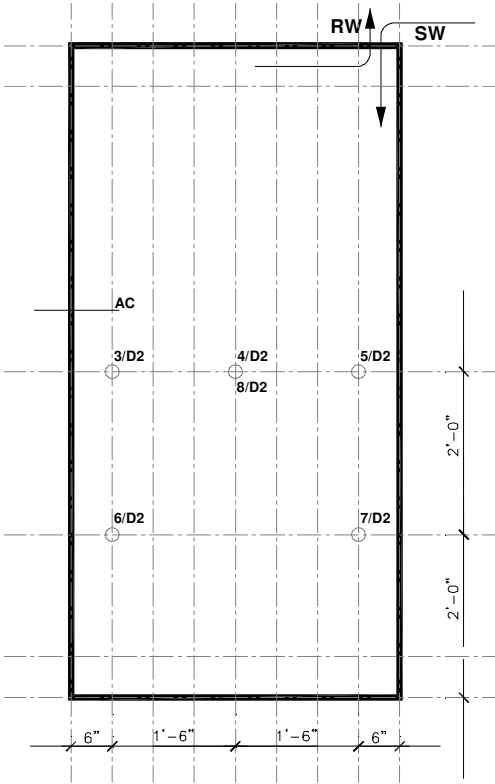

Figure 4-3-3-2a: Test Floor sensor layout



Ceiling sensors: Upper ceiling and underside of test floor (called lower ceiling) have 5 sensors placed as shown in the figure. These sensors provide us with a general idea of the heat transfer from the radiant floor.

Figure 4-3-3-2b: Upper Ceiling sensor layout

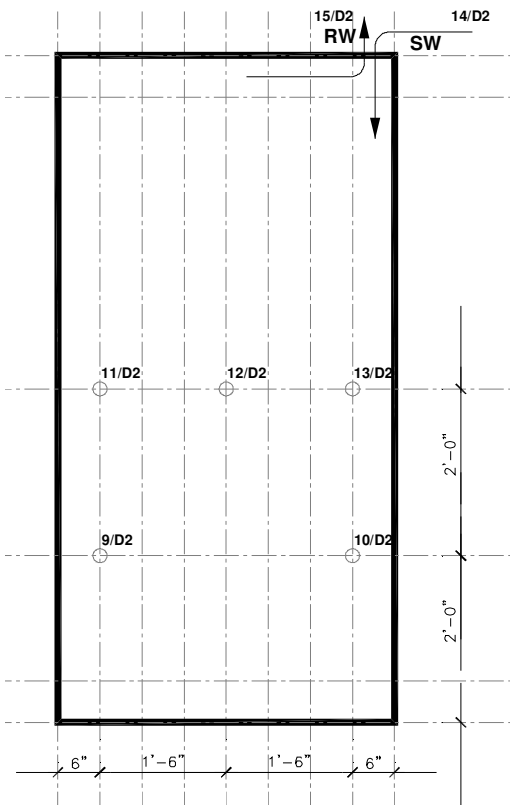

Figure 4-3-3-2c: Lower (underside floor) Ceiling sensor layout

4-3-3-3 Flow sensor- Omega FTB601

Flow Range (LPM): 0.1 - 2

K Factor (Pulses/ L): 36000

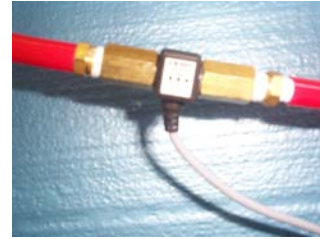

Figure 4-3-3-3a: Flow Sensor (1)

MODEL	Dimensions			
	A (in.)	B (in.)	C (in.)	D (mm. in.)
FTB601	0.4	1.6	0.3	m12 x 1.5

Table 4-3-3-3: Flow Sensor (Dimensional Specs)

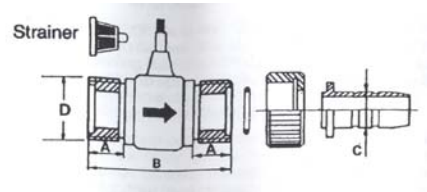

Figure 4-3-3-3b: Flow Sensor (2)

4-3-3-4 Infra-red Thermal Imaging Camera (Wahl Heat Spy® Imager Thermal Imaging Camera) The experiment uses HSI 1000 series thermal imaging camera and an HP pocket PC for recording thermal images of the radiant floors.



Figure 4-3-3-4a: HSI 1000 camera



Figure 4-3-3-4b: HSIPPC Standard Pocket PC

Model Number	HSI1000
	Hand Held Imager
Temperature Range	14F -572F
Field of View	20 deg x 20 deg.

Table 4-3-3-4: HSI 1000 Technical Specifications

V. FINDINGS

This chapter individually documents and analyzes the data gathered for each of the systems. The data recorded is studied under 3 primary performance mandates: Thermal Uniformity, Thermal Stability, and Energy performance.

For ease for comparison, this section is categorized under each performance mandate and not for each radiant system.

Thermal Uniformity: As defined earlier in chapter 3, thermal uniformity of a radiant heating panel is analyzed by measuring the distribution of surface temperature across the test floor. The 7 temperature sensors laid 6” o.c across on the 48” wide test floor device are recorded as separate readings. These are then analyzed together in a graph with the x-axis being the sensor locations spaced 6” and the y-axis being the temperature scale in Fahrenheit. For ease of comparison, the temperature scale on the y-axis in all the graphs is kept similar.

Thermal Stability: As defined earlier in chapter 3, thermal stability of a radiant heating panel is defined as the measure of fluctuation in temperature readings at each sensor location. Data is collected for each experimental run for duration of 90 minutes to 120 minutes. Subsequently, through statistical analysis of the recorded data the maximum, minimum, average and standard deviation values are evaluated for each set. The fluctuations in measurements recorded in a set of data can now be defined as the measure of standard deviation for each set of temperature data. In other words, the larger the standard deviation, the larger is the fluctuation in temperature readings recorded for that experiment. The graphs in chapter 5-2 refer to standard deviation values for temperature readings collected along the cross sectional placement of the sensors.

Energy Performance: Energy performance can be defined as the measure of energy flowing into the floor panel based on supply and return water fluid temperatures. Equation 1, as defined in chapter 2-3-1, is applied to evaluate the total energy flowing inside the test floor device. The panel design parameters specifications for each test floor directly impacts the energy absorption that occurs within the test floor.

5-1 Thermal Uniformity

The distribution temperature sensors across the test floor aid in analyzing thermal uniformity of the radiant system.

As referred in the sensor layout (discussed in chapter 4), sensor #3 to sensor#9 on the DL1 (Data-Logger 1) refer to readings observed on panel surface across central cross-section. The following graphs elaborate on the thermal uniformity of each system.

5-1-1 RAUPANEL 6" o.c- w/o Insulation

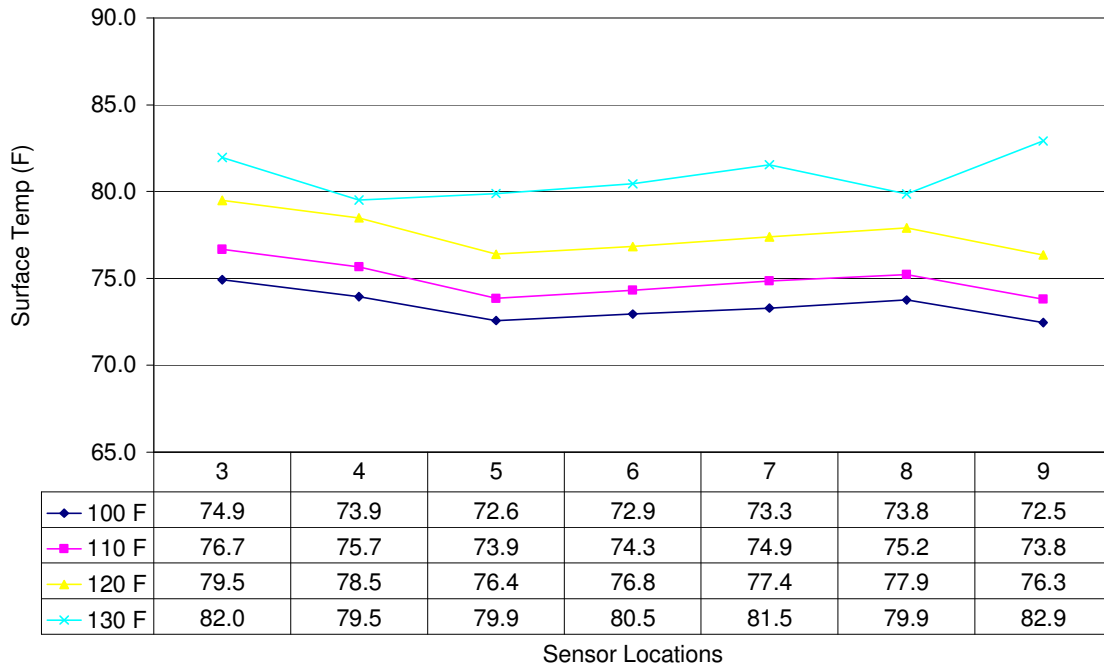

Graph 5-1-1: Surface Temperature Distribution along sensors 3- 9 (RAUPANEL 6" o.c- w/o R13)

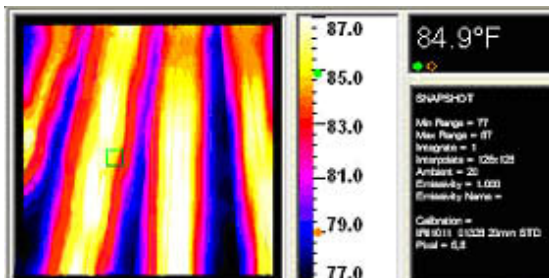

Figure 5-1-1a: I.R image at $T_{sw} = 100$ F

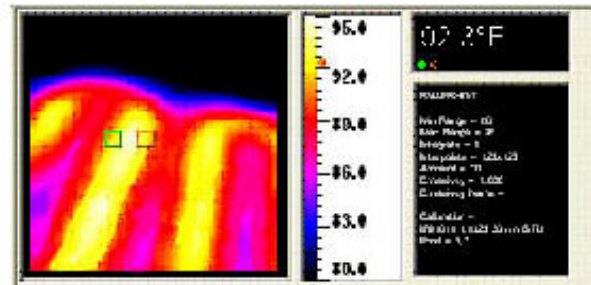
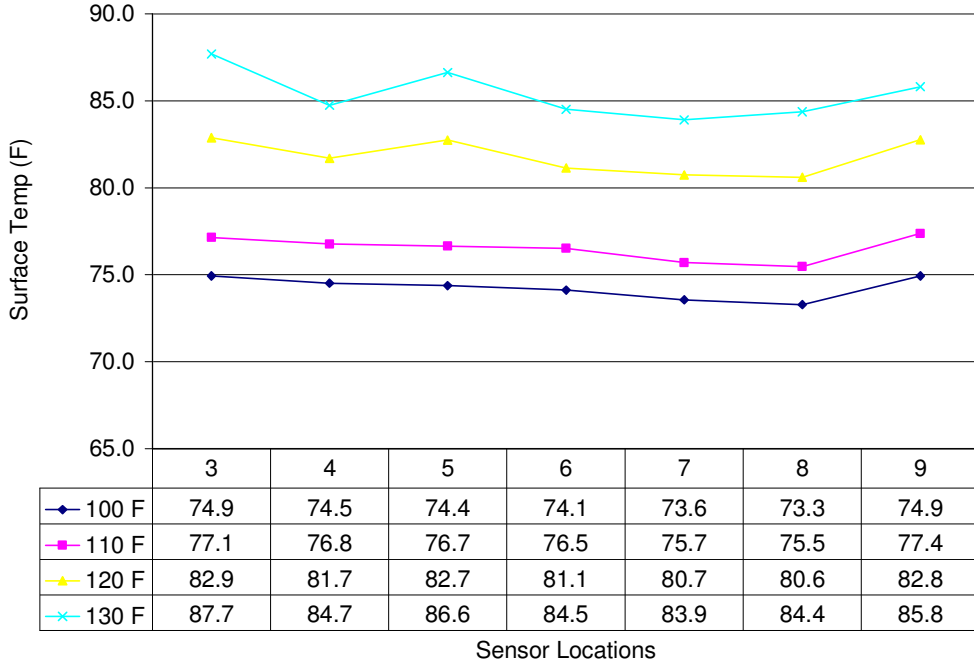

Figure 5-1-1b: I.R image at $T_{sw} = 120$ F

5-1-2 RAUPANEL 6” o.c- w/ Insulation



Graph 5-1-2: Surface Temperature Distribution along sensors 3- 9 (RAUPANEL 6” o.c- w/ R13)

5-1-3 RAUPANEL 8” o.c- w/o Insulation

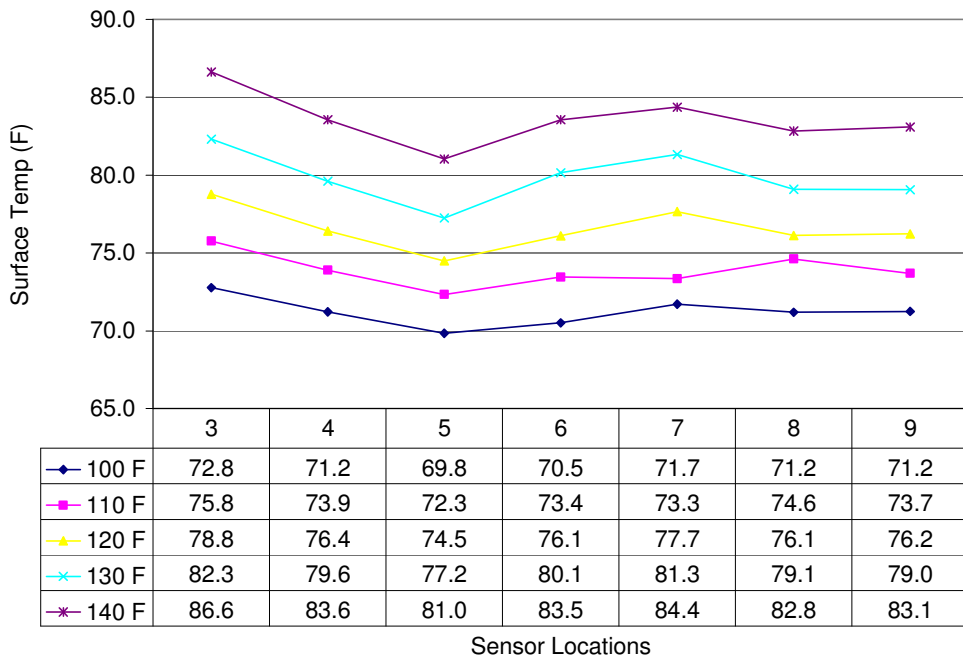

Graph 5-1-3: Surface Temperature Distribution along sensors 3- 9 (RAUPANEL 8” o.c- w/o R13)

5-1-4 RAUPANEL 8" o.c- w/ Insulation

Raupanel 8" o.c. - R13 Insulation

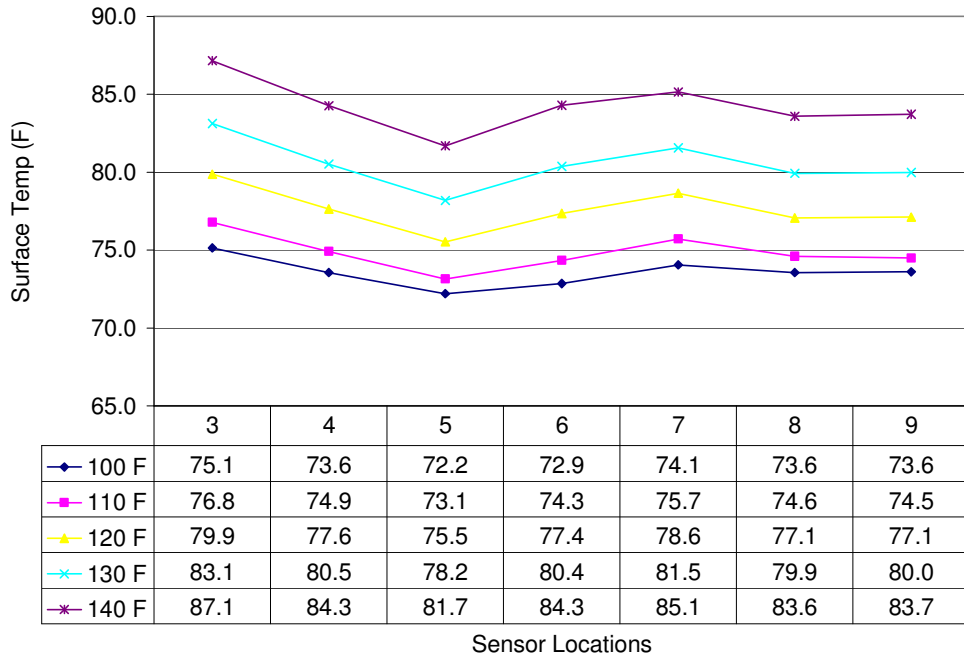

Graph 5-1-4: Surface Temperature Distribution along sensors 3- 9(RAUPANEL 8" o.c- w/ R13)

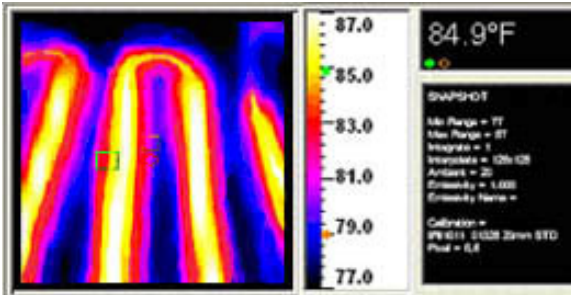

Figure 5-1-4a: I.R image at $T_{sw} = 100$ F

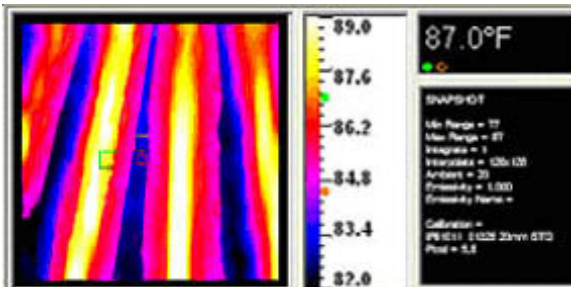
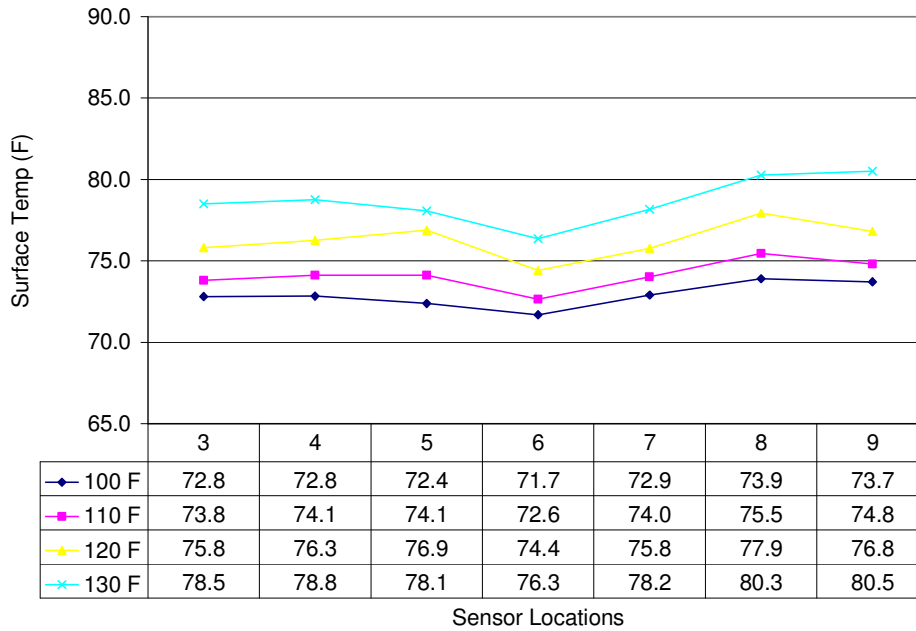

Figure 5-1-4b: I.R image at $T_{sw} = 110$ F

5-1-5 THERMALBOARD 8" o.c.- w/ Insulation



Graph 5-1-5: Surface Temperature Distribution along sensors 3- 9 (RAUPANEL 8" o.c.- w/ R13)

5-1-6 WARMBOARD

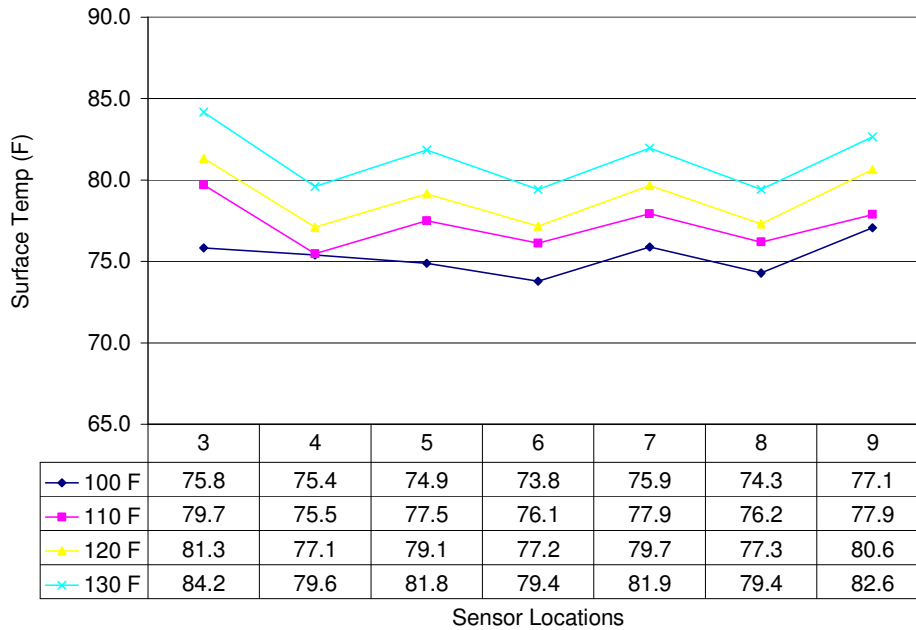

Graph 5-1-6: Surface Temperature Distribution along sensors 3- 9 (WARMBOARD)

5-1-7 QUICKTRACK- WIRSBO

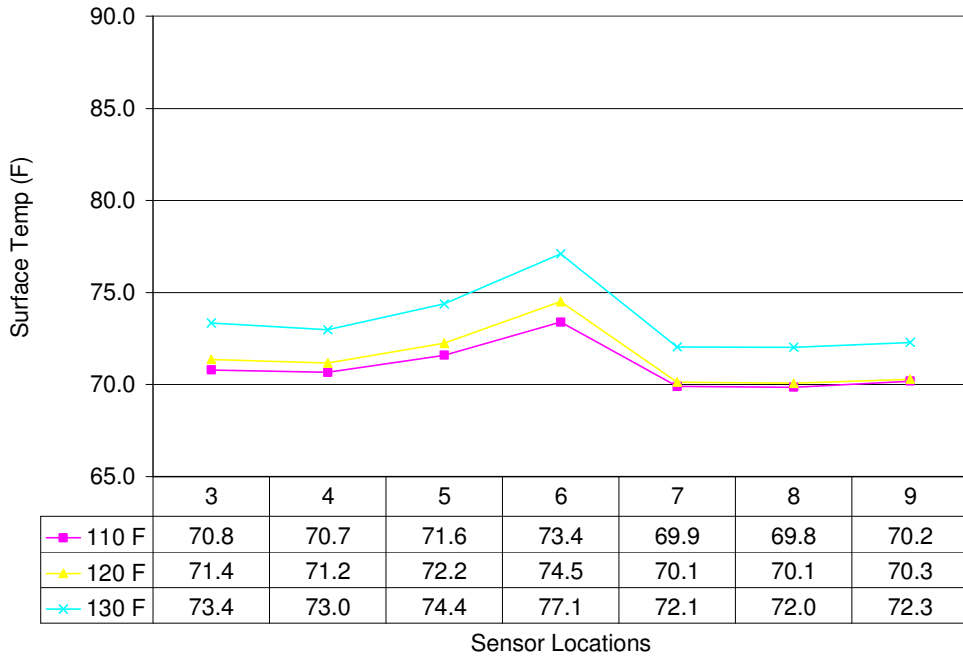

Graph 5-1-7: Surface Temperature Distribution along sensors 3- 9 (QUICKTRAK)

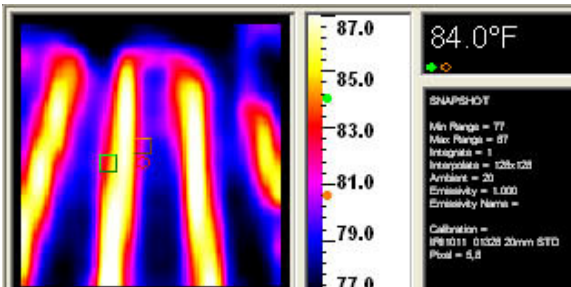

Figure 5-1-7a: I.R. image at $T_{sw} = 100$ F

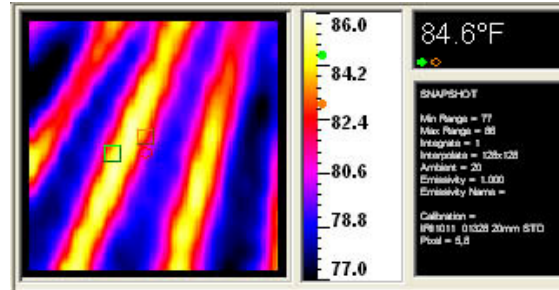

Figure 5-1-7b: I.R. image at $T_{sw} = 110$ F

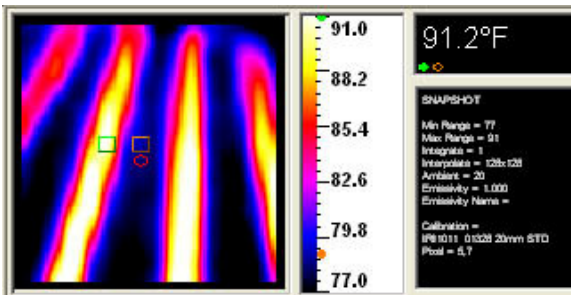

Figure 5-1-7c: I.R. image at $T_{sw} = 120$ F

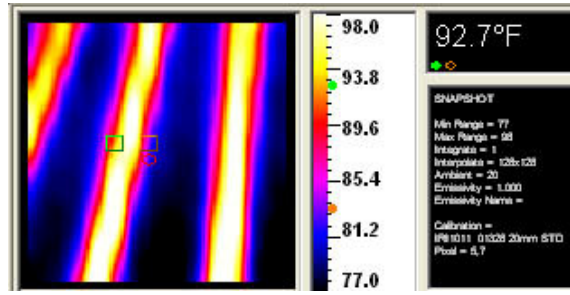
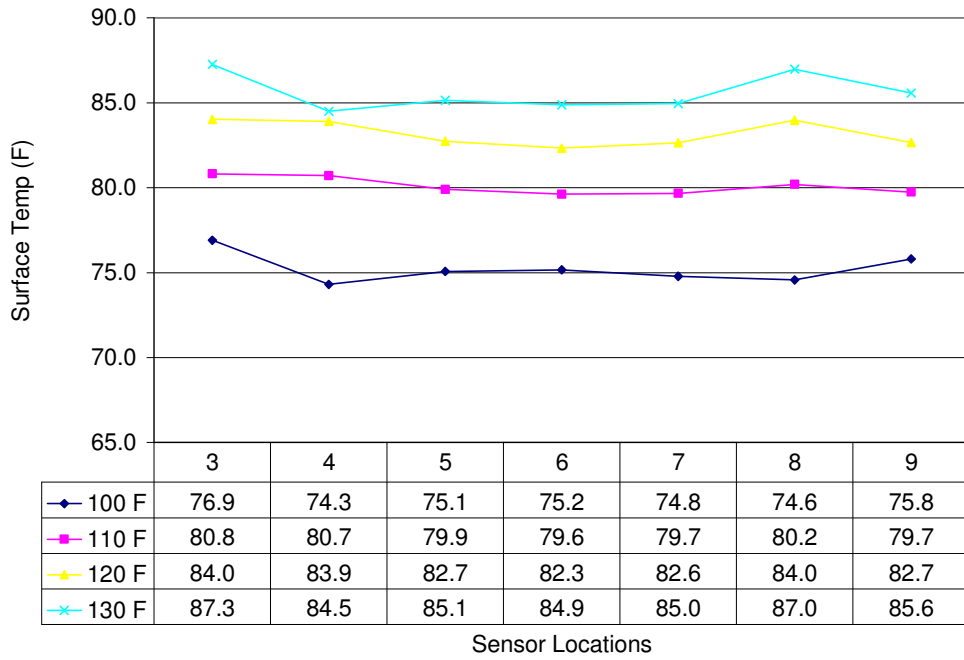

Figure 5-1-7d: I.R. image at $T_{sw} = 130$ F

5-1-8 ROTH 6'' o.c- w/ Insulation



Graph 5-1-8: Surface Temperature Distribution along sensors 3- 9 (ROTH 6'' o.c- w/ R13)

5-1-9 GYPCRETE w/ Insulation

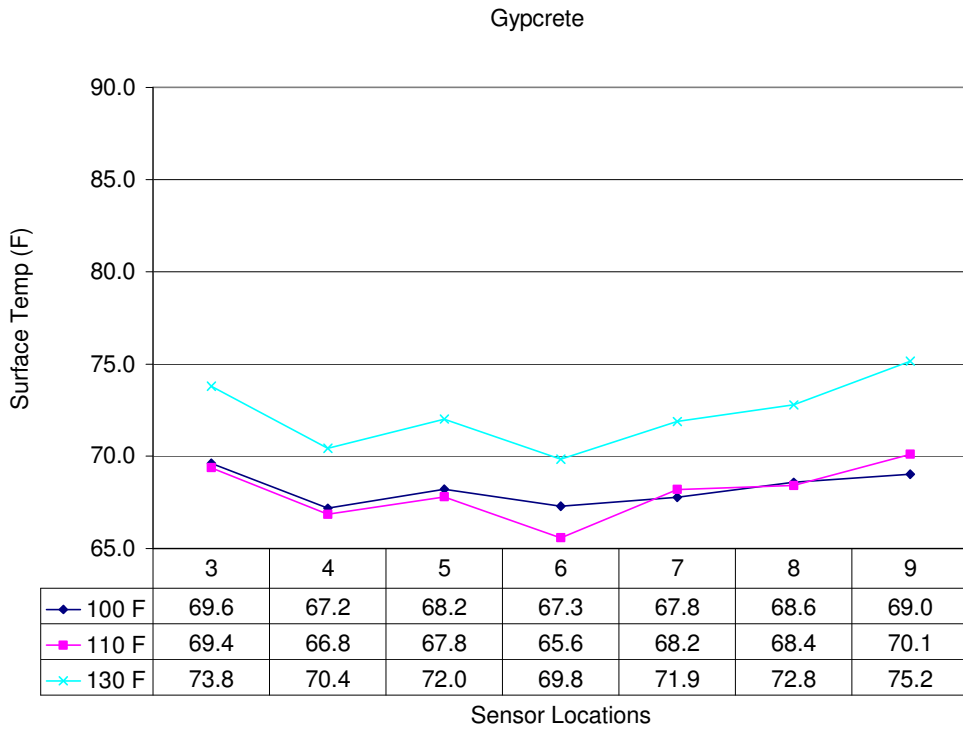

Graph 5-1-9: Surface Temperature Distribution along sensors 3-9 (GYPCRETE)

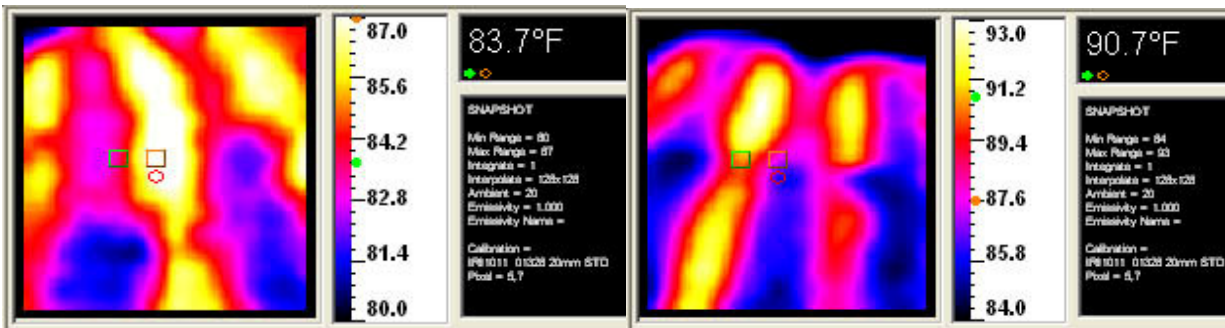

Figure 5-1-9a: I.R image at $T_{sw} = 100$ F

Figure 5-1-9b: I.R image at $T_{sw} = 110$ F

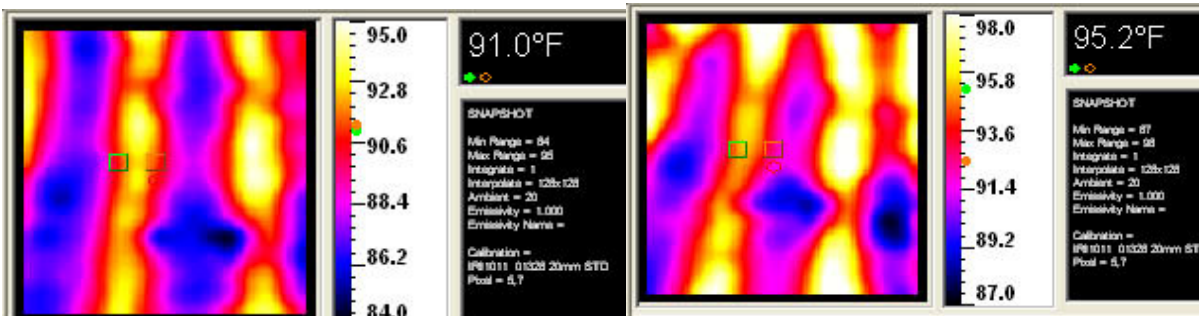
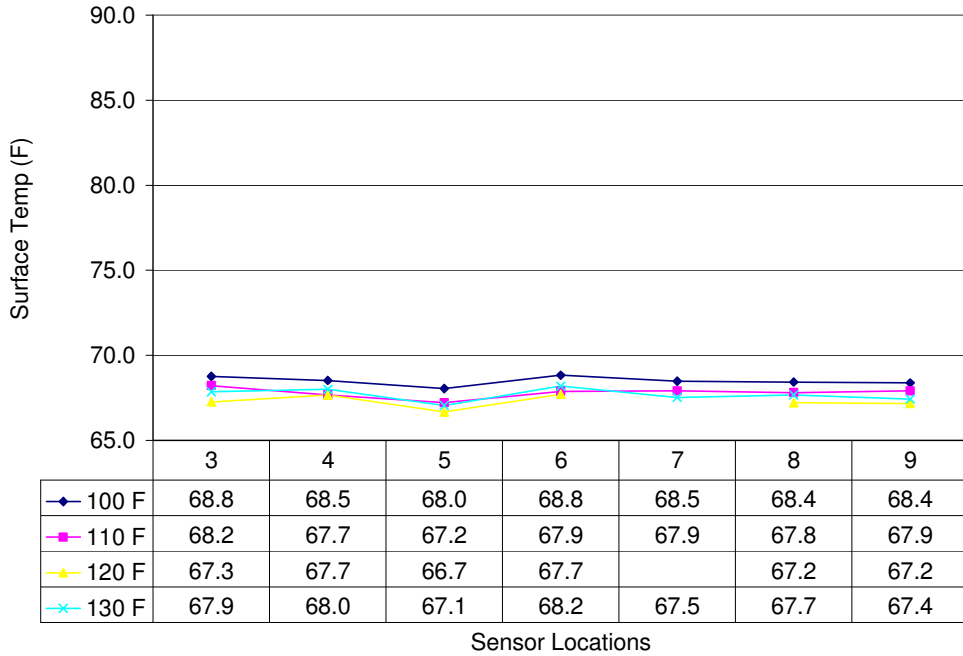

Figure 5-1-9c: I.R image at $T_{sw} = 120$ F

Figure 5-1-9d: I.R image at $T_{sw} = 130$ F

5-1-10 ULTRAFIN - w/ Insulation



Graph 5-1-10: Surface Temperature Distribution along sensors 3- 9(ULTRAFIN w/ R19)

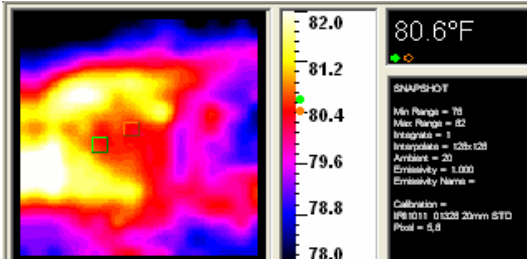

Figure 5-1-10a: I.R. image at $T_{sw} = 100$ F

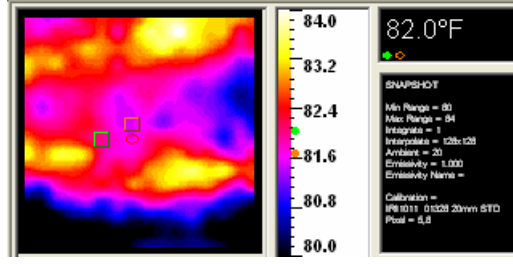

Figure 5-1-10b: I.R. image at $T_{sw} = 110$ F

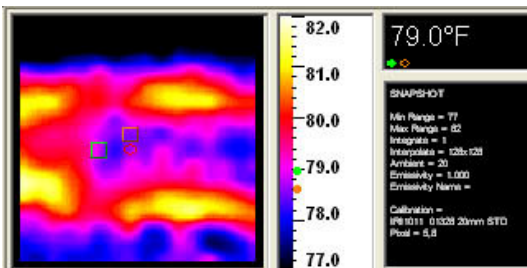

Figure 5-1-10c: I.R. image at $T_{sw} = 120$ F

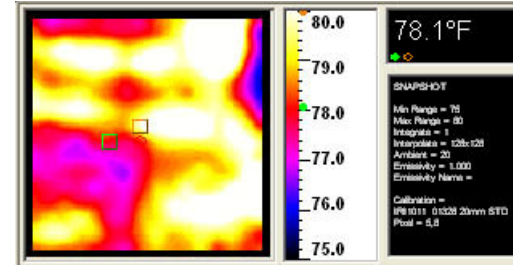
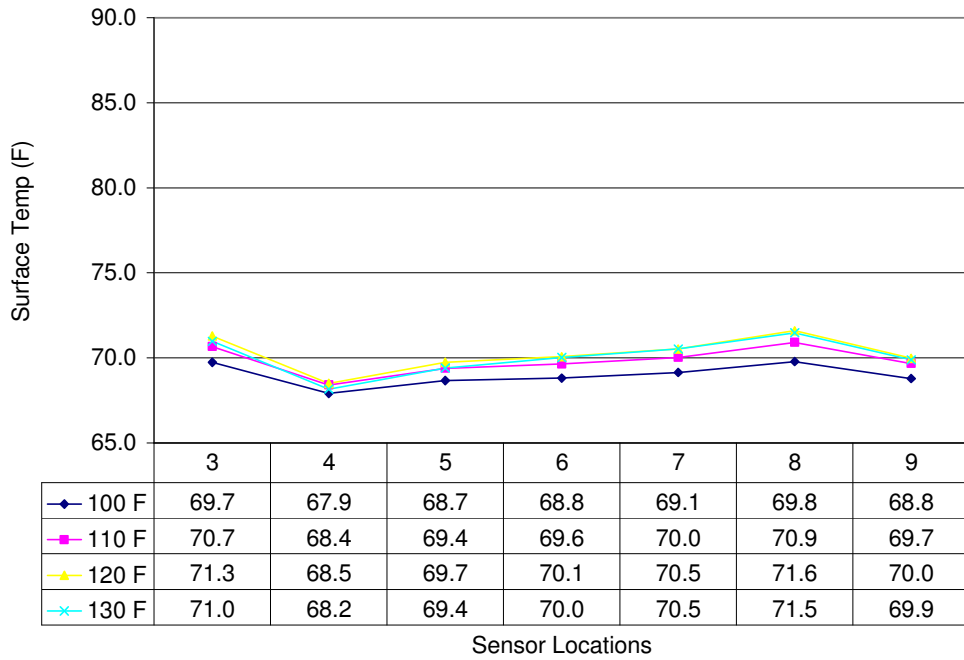

Figure 5-1-10d: I.R. image at $T_{sw} = 130$ F

UltraFin transfers heat to the floor surface through the 2” thick layer of air between tube/ fins to the subfloor because of which the heat spread on the floor (as seen in the figure above) does not follow a set pattern and is wide spread.

5-1-11 JOIST SPACE w/o plates w/ Insulation



Graph 5-1-11: Surface Temperature Distribution along sensors 3- 9 (JOIST SPACE w/o PLATES w/ R19)

5-1-12 JOIST SPACE w/ plates w/ Insulation

Joist Space - With Plates

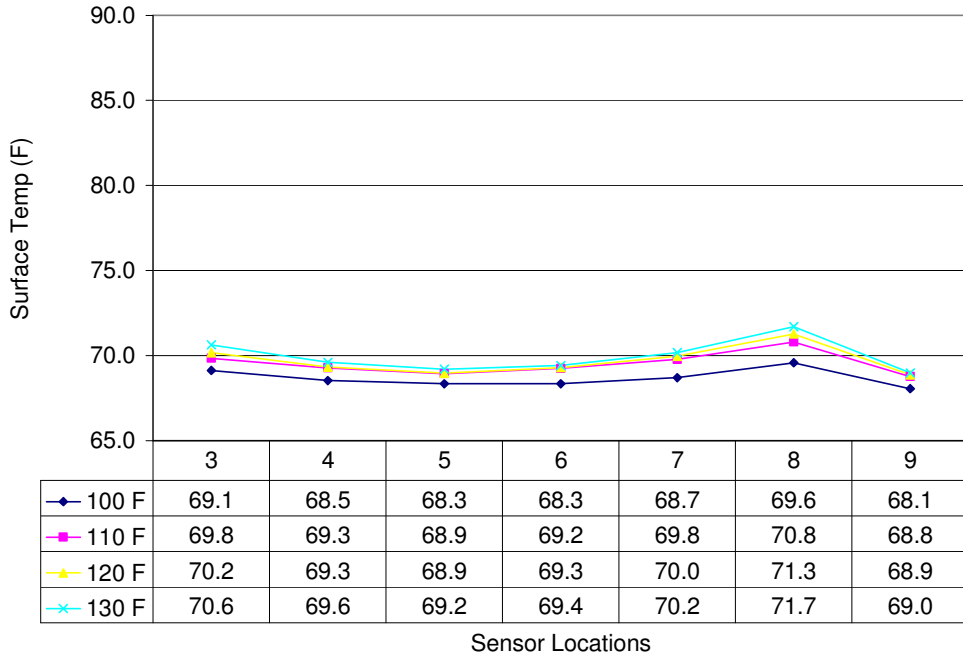

Graph 5-1-12: Surface Temperature Distribution along sensors 3- 9 (JOIST SPACE w/ PLATES w/ R19)

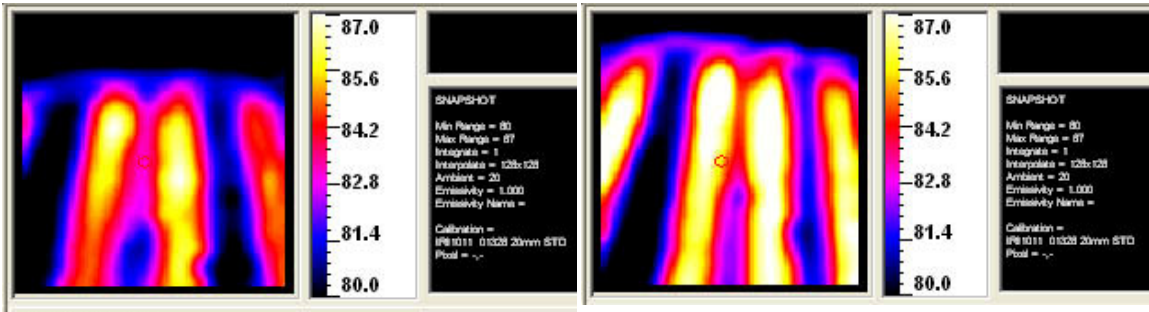

Figure 5-1-12a: I.R image at $T_{sw} = 100$ F

Figure 5-1-12b: I.R image at $T_{sw} = 110$ F

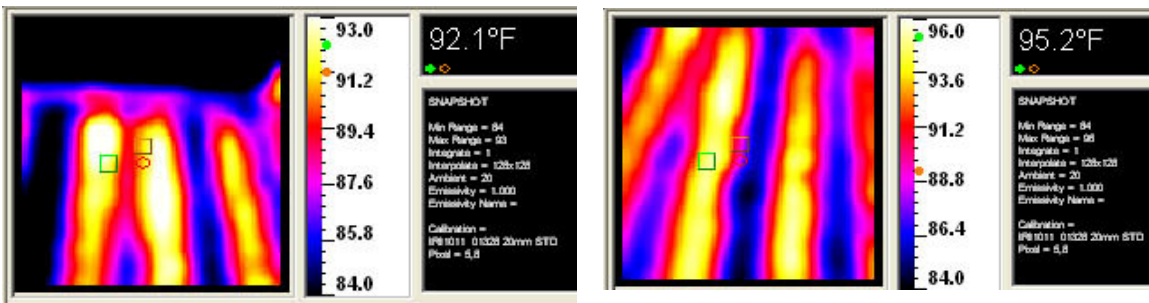

Figure 5-1-12c: I.R image at $T_{sw} = 120$ F

Figure 5-1-12d: I.R image at $T_{sw} = 130$ F

5-2 HEAT TRANSFER

5-2-1 Overall Heat Transfer to Test Floor system

This section shows total heat loss based on fluid readings (supply- return). Each graph depicts heat transfer occurring on a standard 32 sft. radiant panel at controlled (mentioned at each graph) supply water temperatures, and static flow rate of 0.5 gpm.

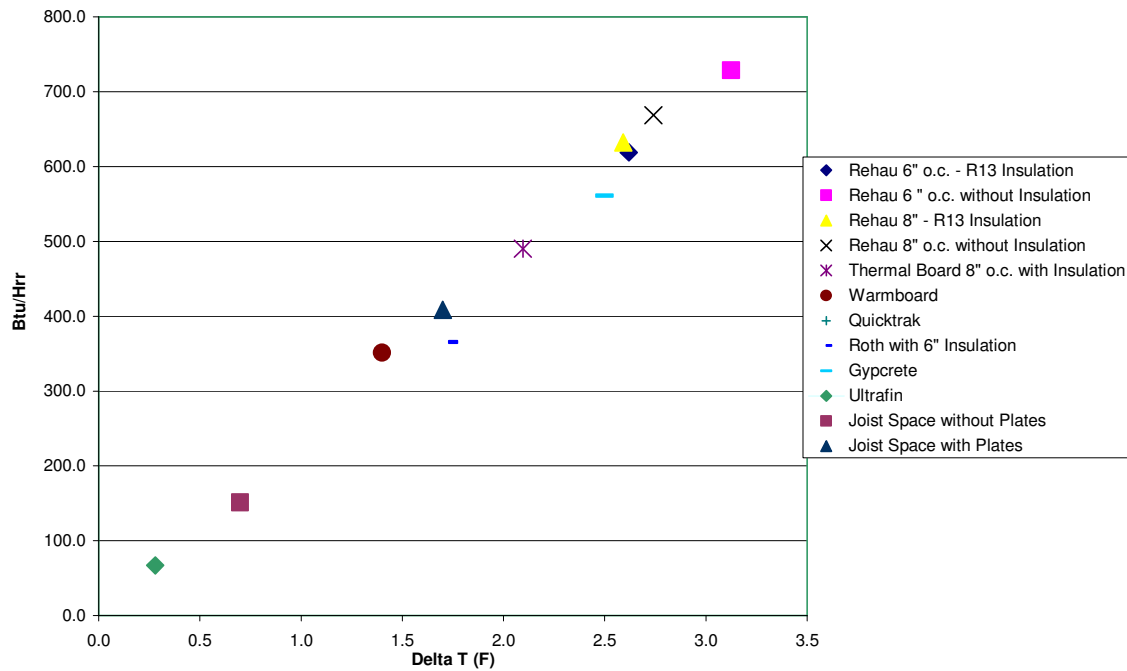

Graph 5-2-1: Overall Heat Transfer to test floor Comparison at $T_{sw} = 100F$
Flow rate= 0.5 GPM, Test Area= 32 SF.

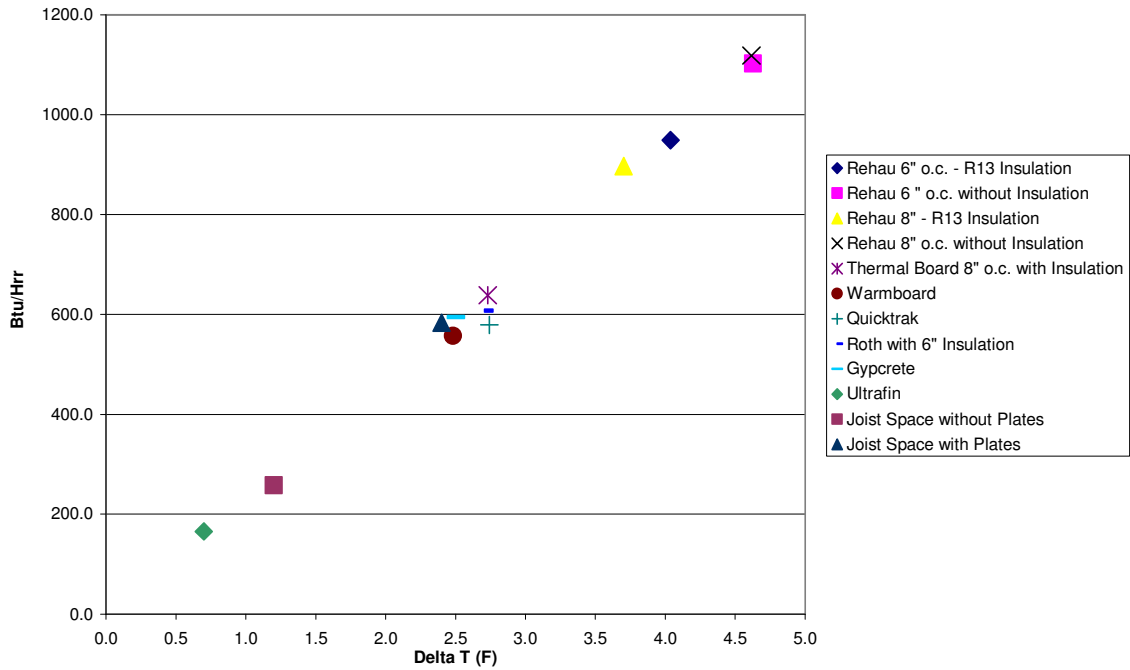

Graph 5-2-2: Overall Heat Transfer to test floor Comparison at $T_{sw} = 110F$
Flow rate= 0.5 GPM, Test Area= 32 SF.

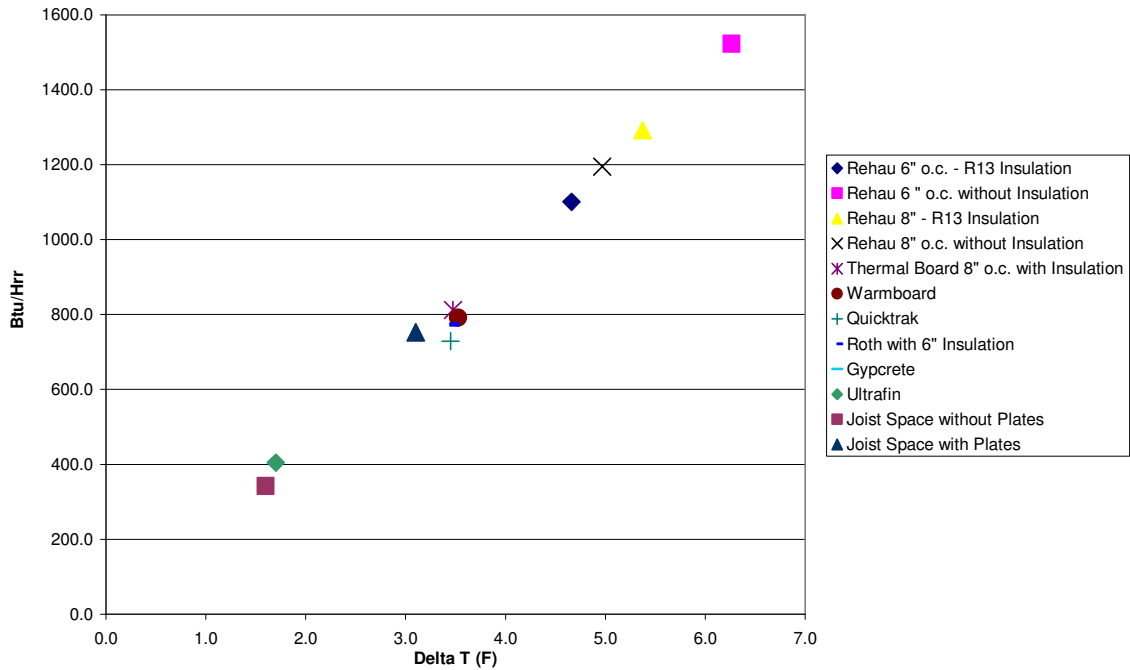

Graph 5-2-3: Overall Heat Transfer to test floor Comparison at $T_{sw} = 120F$,
Flow rate= 0.5 GPM, Test Area= 32 SF.

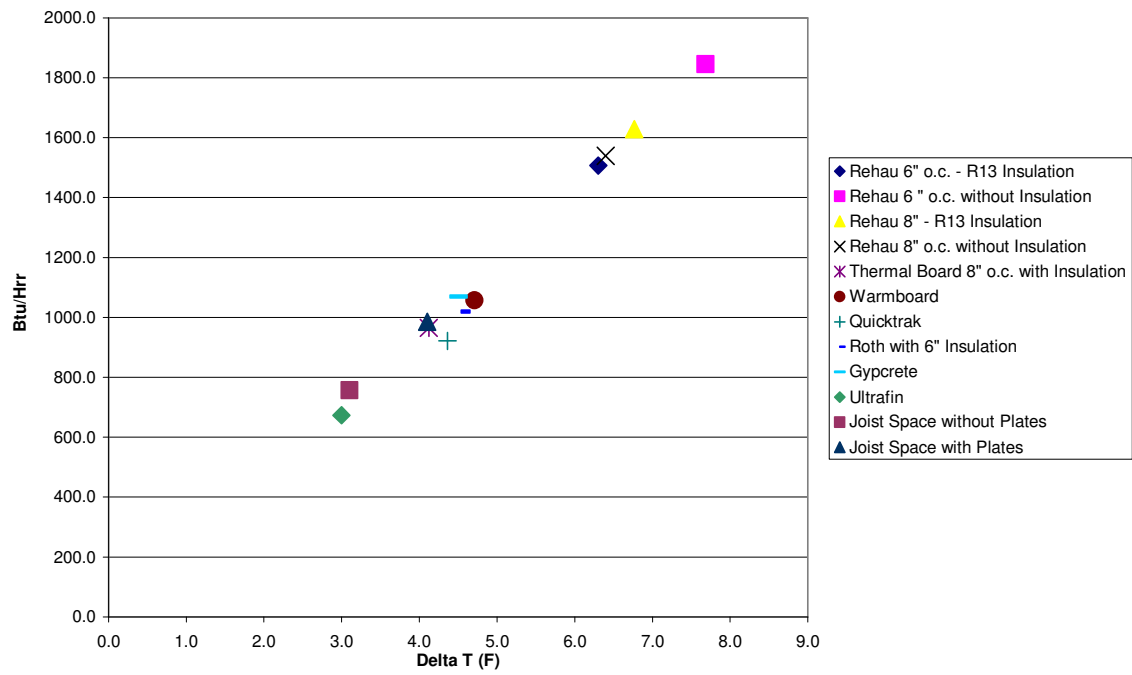

Graph 5-2-4: Overall Heat Transfer to test floor Comparison at $T_{sw} = 130F$,
Flow rate= 0.5 GPM, Test Area= 32 SF.

5-3 THERMAL STABILITY

Thermal stability can be referred to as the measure of fluctuation occurring at each location on the panel surface. This is separate from thermal uniformity in the sense that it involves observing variations in temperature readings at a single location. On the other hand, thermal uniformity considers temperature variations across different locations on the radiant panel.

In consistence with the theory of radiant technology, time variations on thermal response of each panel are dependent on the transient conditions it faces during the experiment. The fluctuations are a result of the impact of alteration in parameters such as flow temperature, flow rate, and/ or indoor air conditions. While these parameters are controlled in the experiment, the accuracy of each instrument may have a limited impact on the performance of the radiant panel. Thermal stability gives us a measure of the strength of the panel to withhold such alterations in conditions.

Standard deviation gives a measure of average variation in sample readings from the mean average of the sample. In respect with this study, we evaluate the standard deviations of temperature readings at each sensor location on the central cross-section of the test floor. Lesser the standard deviation, more thermally stable is the performance of the test floor panel.

5-3-1 RAUPANEL 6" o.c- w/o Insulation

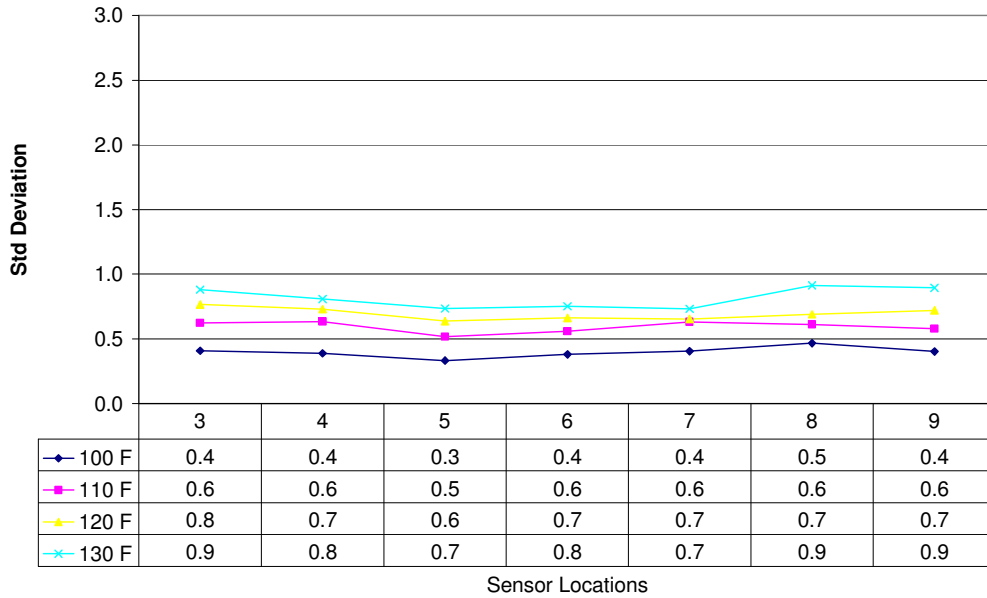

Graph 5-3-1: Stability Performance (RAUPANEL 6" o.c w/o R13)

5-3-2 RAUPANEL 6" o.c- w/ Insulation

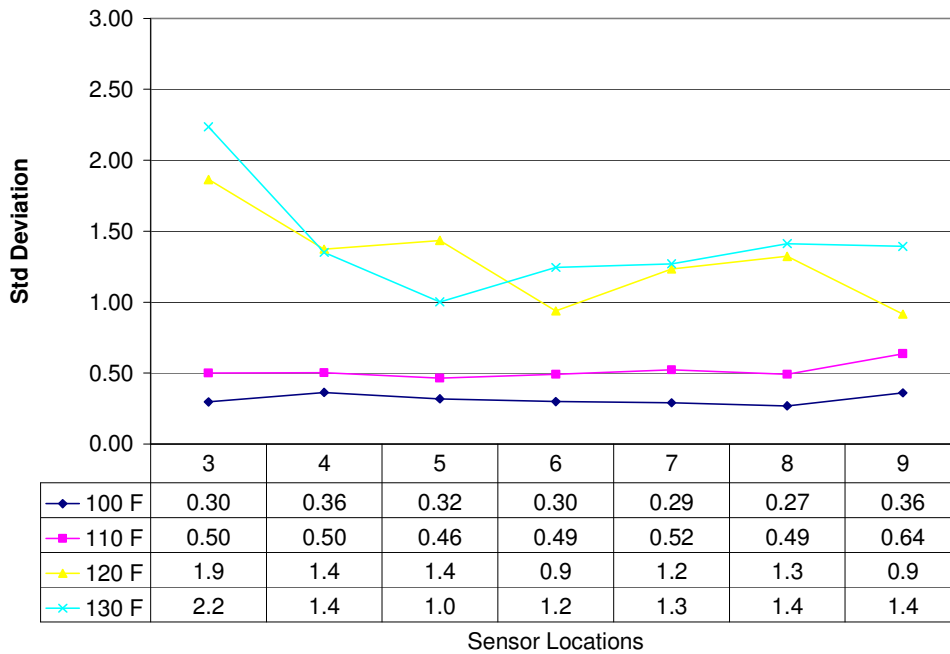

Graph 5-3-2: Stability Performance (RAUPANEL 6" o.c w/R13)

5-3-3 RAUPANEL 8" o.c- w/o Insulation

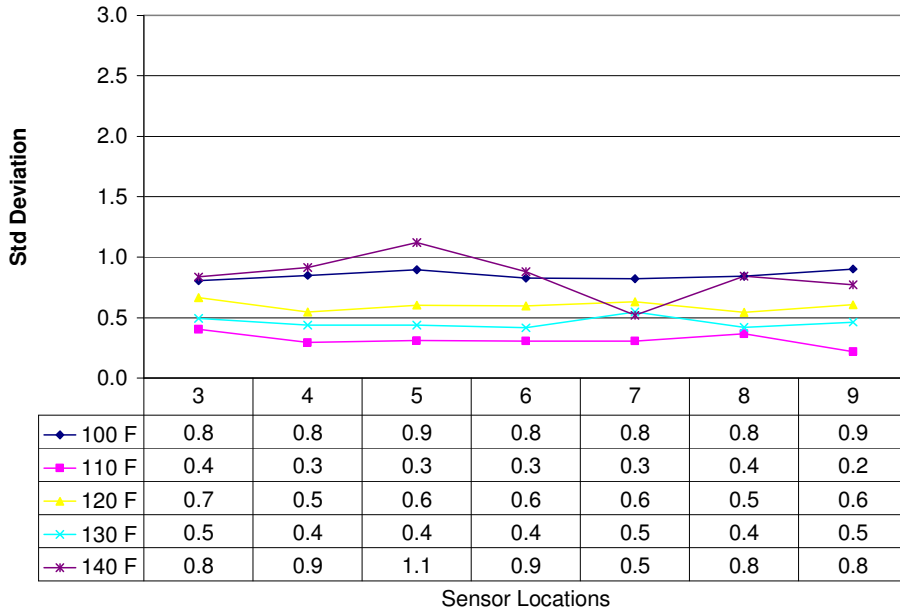

Graph 5-3-3: Stability Performance (RAUPANEL 8" o.c w/o R13)

5-3-4 RAUPANEL 8" o.c- w/ Insulation

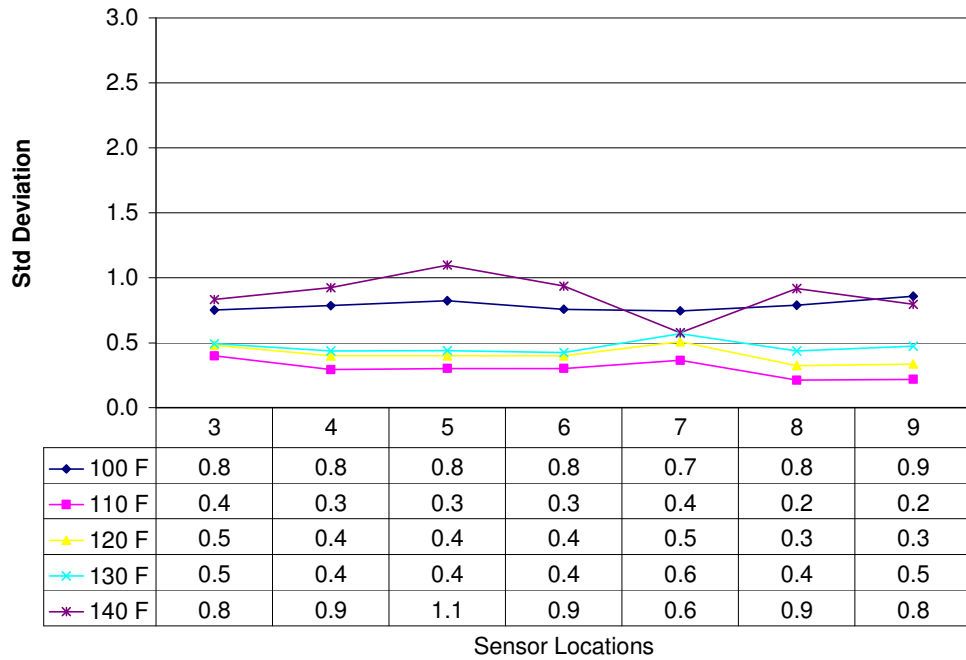

Graph 5-3-4: Stability Performance (RAUPANEL 8" o.c w/R13)

5-3-5 THERMALBOARD w/ Insulation

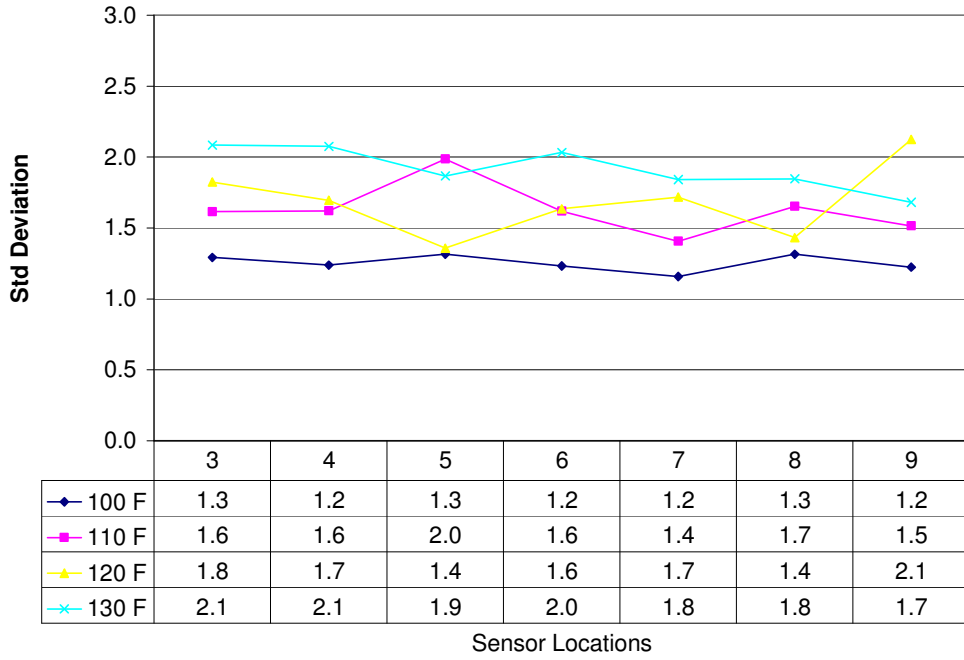

Graph 5-3-5: Stability Performance (THERMALBOARD 8" o.c w/R13)

5-3-6 WARMBOARD

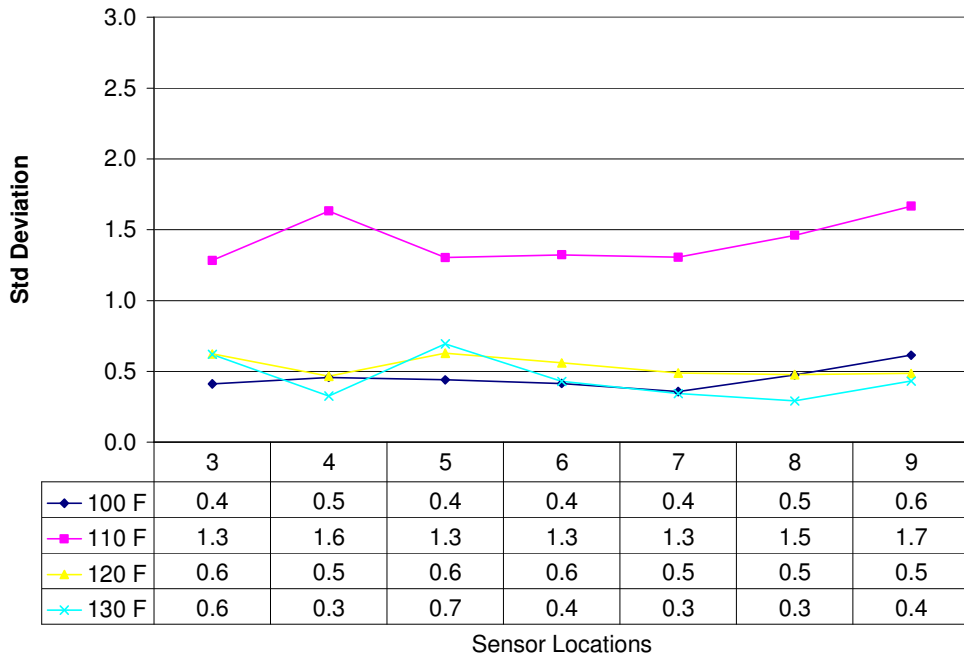

Graph 5-3-6: Stability Performance (WARMBOARD w/R13)

5-3-7 QUICKTRAK

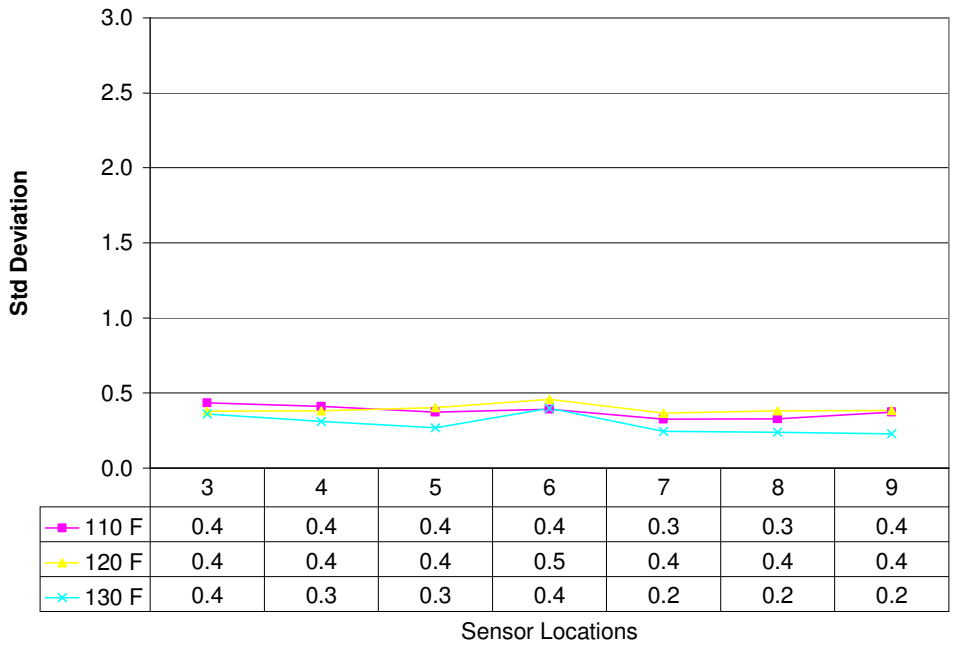

Graph 5-3-7: Stability Performance (QUICKTRAK w/R13)

5-3-8 ROTH w/ Insulation

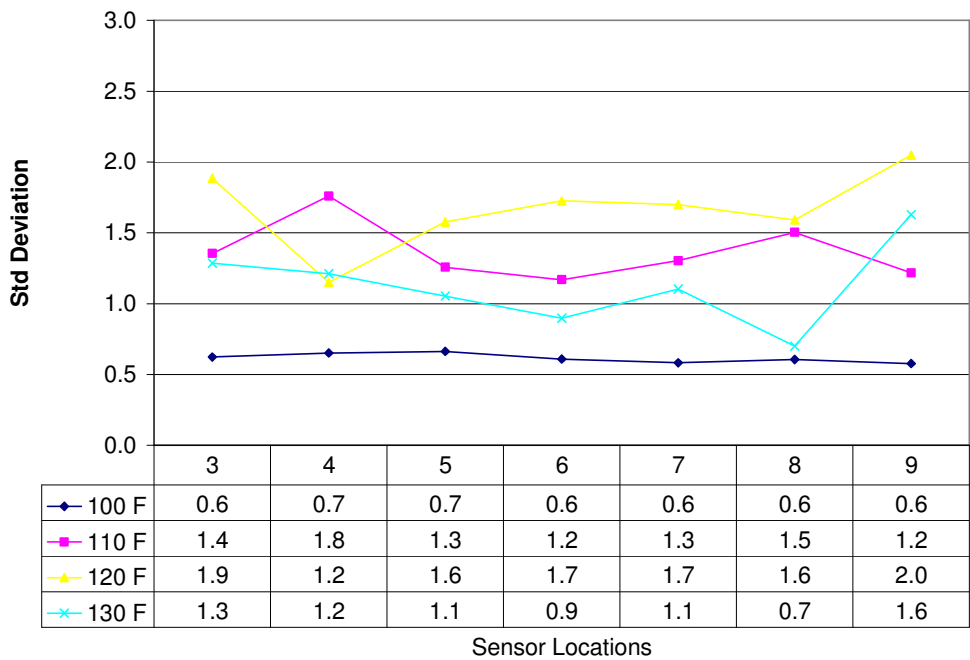

Graph 5-3-8: Stability Performance (ROTH w/R13)

5-3-9 GYPCRETE

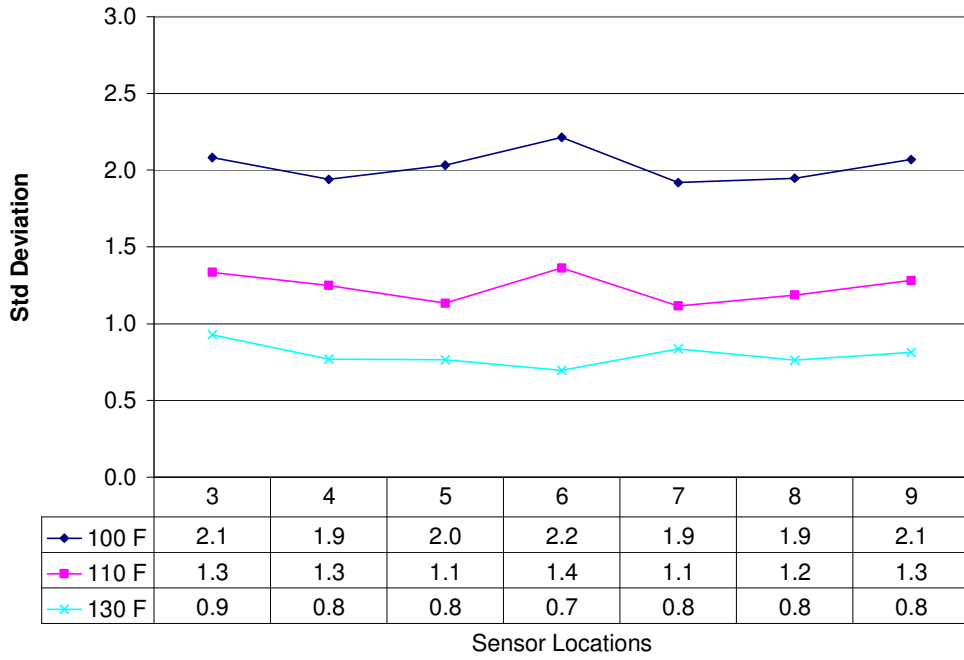

Graph 5-3-9: Stability Performance (GYPCRETE)

5-3-10 ULTRAFIN

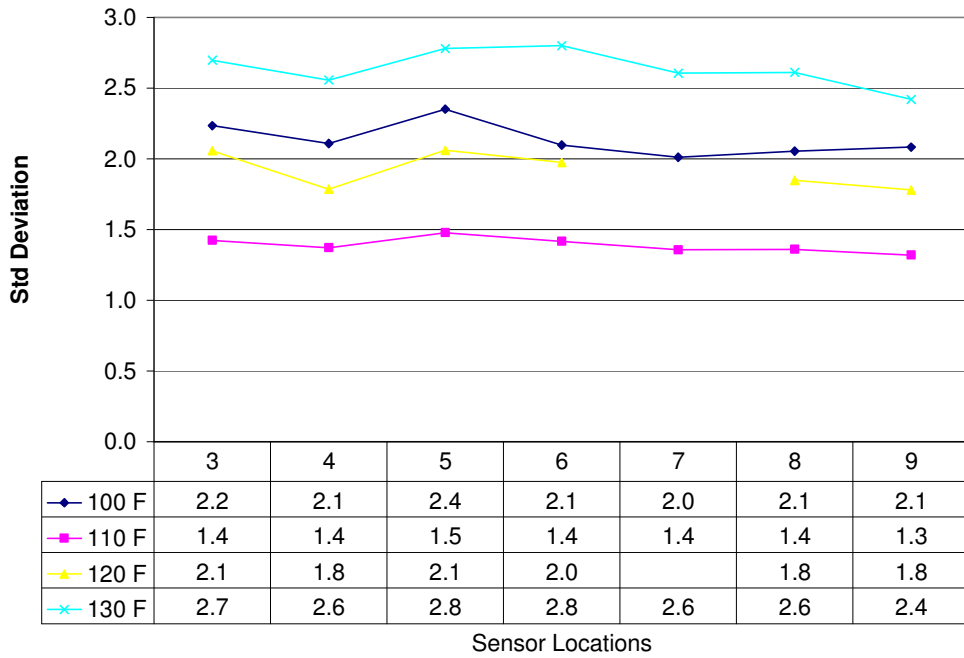

Graph 5-3-10: Stability Performance (ULTRAFIN w/R19)

5-3-11 JOIST SPACE - w/o Plates

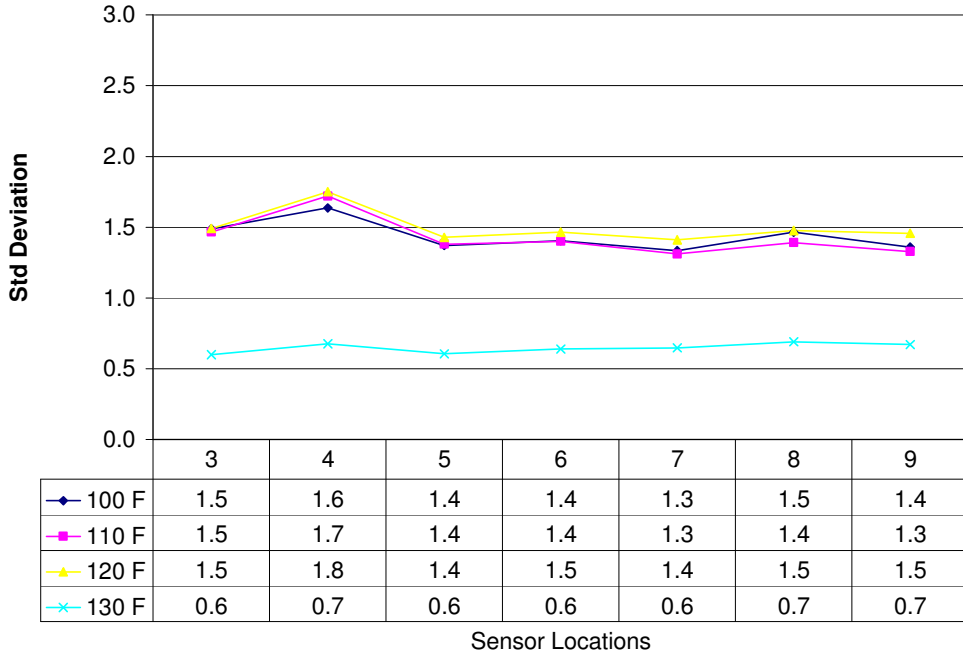

Graph 5-3-11: Stability Performance (JOIST SPACE w/o R19)

5-3-12 JOIST SPACE - w/ Plates

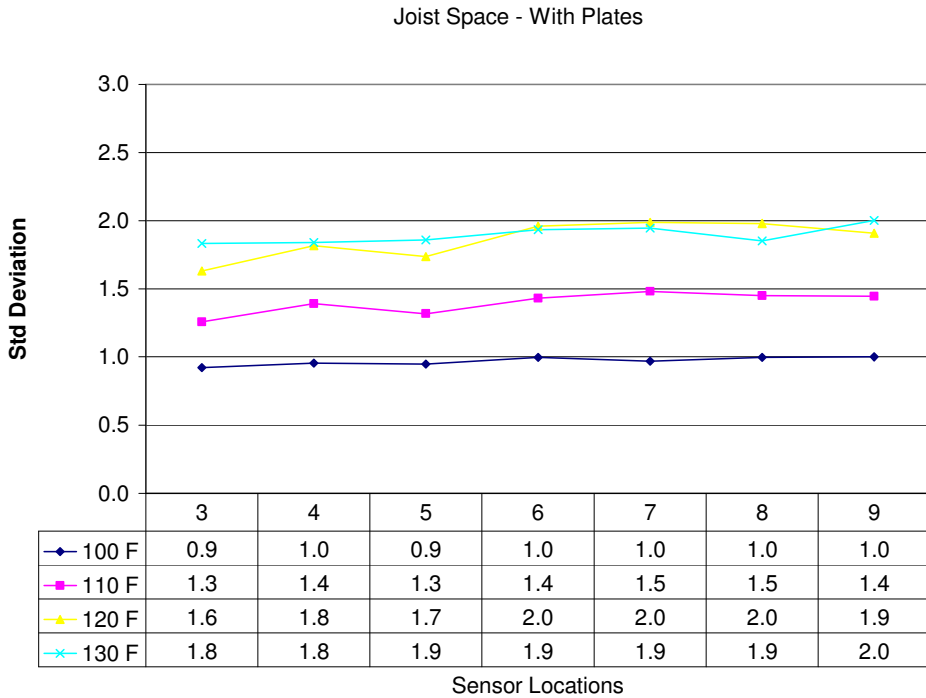

Graph 5-3-12: Stability Performance (JOIST SPACE w/R19)

VI. Results and Discussions

Radiant-floor heating turns a floor into a large-area, low-temperature radiator. Design of radiant-floor heating systems is quite complex and should be done by someone with adequate training or experience. As mentioned earlier in this paper, initiatives by manufacturers have been most helpful in propagating radiant heating technology. Various design manuals, manufacturer-specific installation guides, and software tools are available for use in designing and sizing radiant floor heating systems. The length of tubing required per square foot of floor depends on such variables as tubing diameter, type of radiant-floor system (thick slab, thin slab, no slab), climate, heat load of the building, and type of boiler and controls used.

This study investigates issues of thermal performance comparing them for 12 different radiant floor heating system panels. Useful readings, as documented in chapter V. have assisted in concluding on the measure of thermal uniformity, thermal stability and energy efficiency of the systems.

This chapter discusses relevant results and draws conclusions with respect to the hypothesis believed in the beginning of this study.

6-1 Hypothesis 1

Radiant systems with conducting panel make achieve higher finished floor surface temperatures under similar supply water temperatures and consequentially achieve higher heat transfer to the space, when compared with systems having non-conducting panel make.

Temperature recordings, when compared at each supply water temperature (100F – 140F), show that Raupanel systems (from Rehau) and Roth system have performed exceeding well. These systems achieve surface temperatures ranging between 74 F and 86 F corresponding to supply water temperatures for 100F – 140F. The panel make of Raupanel is extruded aluminum and Roth system make is MDF- aluminum.

Most other system panels are made of plywood which is a bad conductor of heat. Thus, we observe that systems achieving high surface temperatures have aluminum panels. Aluminum panels collect good heat from PEX pipe running through them and

efficiently pass it to the finished floor above. As clear from the graphs presented in sections 5-2-1 and 5-2-2, these systems have higher heat transfer potential.

6-2 Hypothesis 2

Radiant systems with metallic (aluminum) panel surface have more uniform thermal distribution over panel surface compared to systems with non-conducting make.

- Raupanel 6” o.c and Roth radiant heating systems perform most uniformly for all supply water temperatures between 100F and 140F.
- Other Raupanel configurations perform only next to the above systems.

This validates our hypothesis that systems with metallic panel surface perform uniformly than radiant panels with non-conducting panel surfaces. The conducting panels are better capable of absorbing and spreading heat from PEX tube.

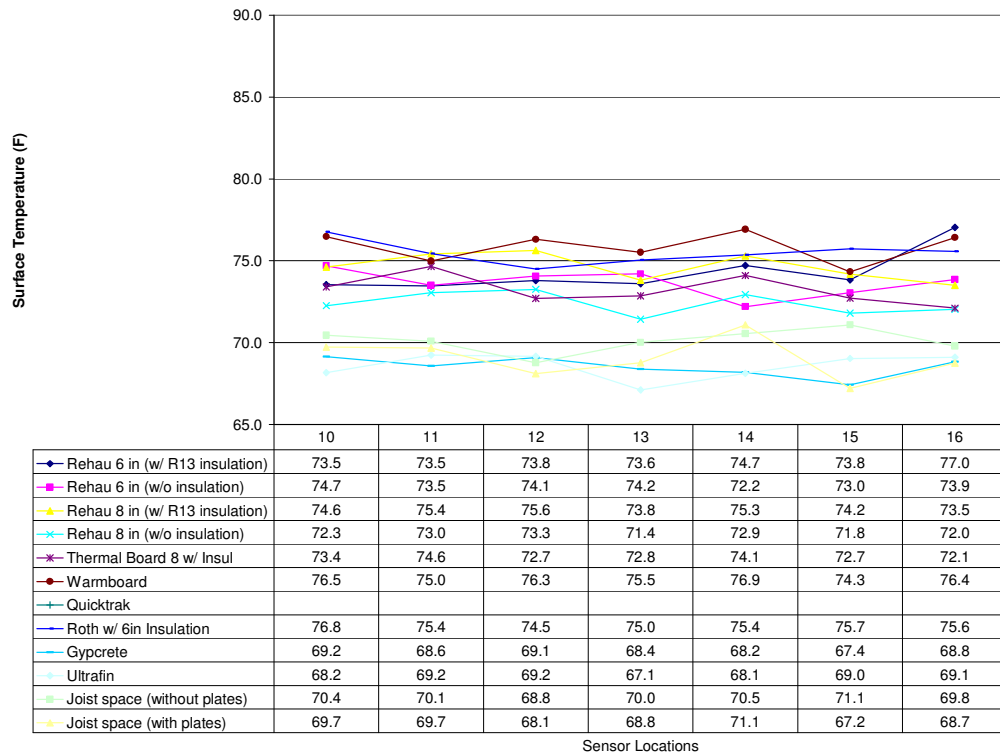

Graph 6-1: Surface Temperature Distribution Comparison at $T_{sw} = 100$ F

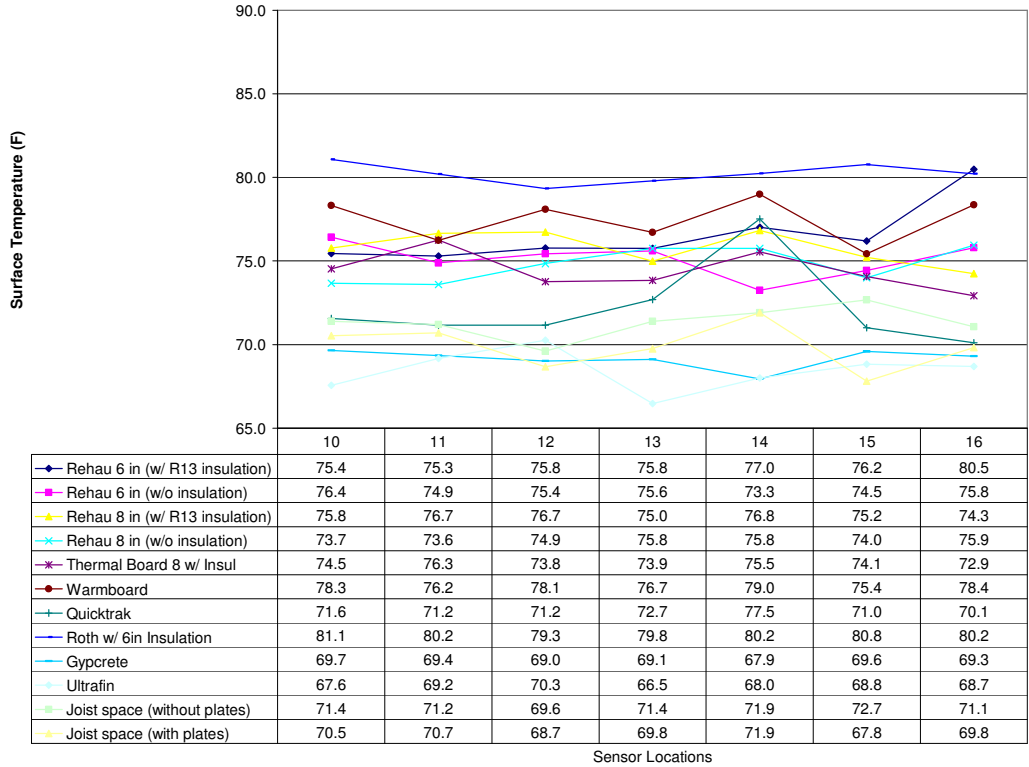

Graph 6-2: Surface Temperature Distribution Comparison at $T_{sw}= 110$ F

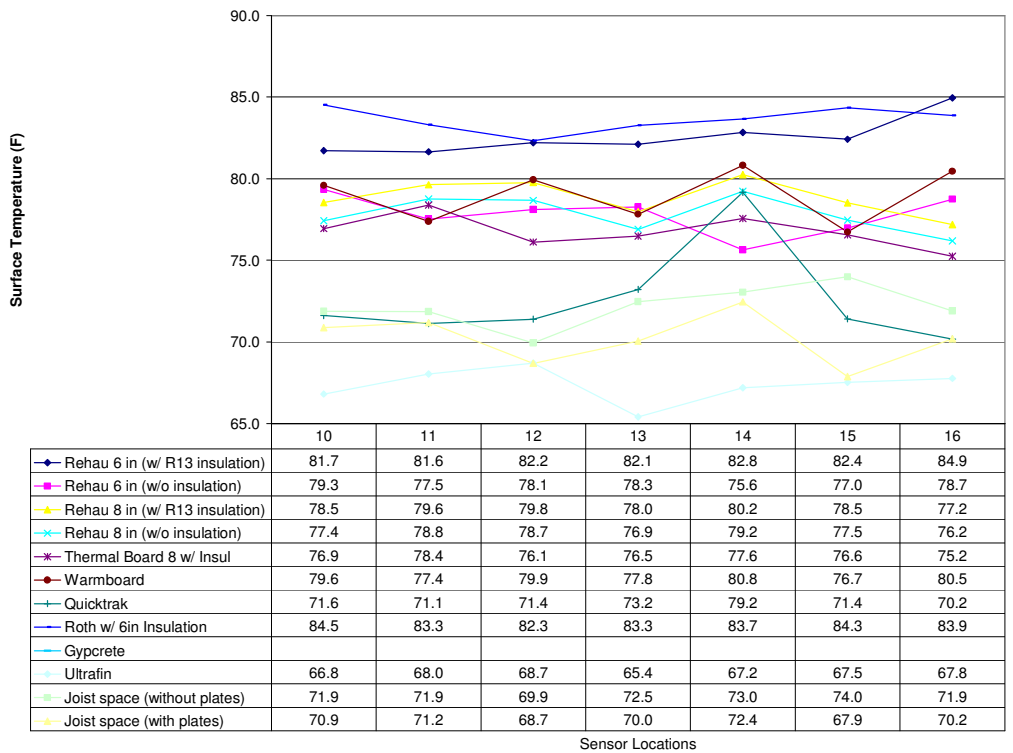

Graph 6-3: Surface Temperature Distribution Comparison at $T_{sw}= 120$ F

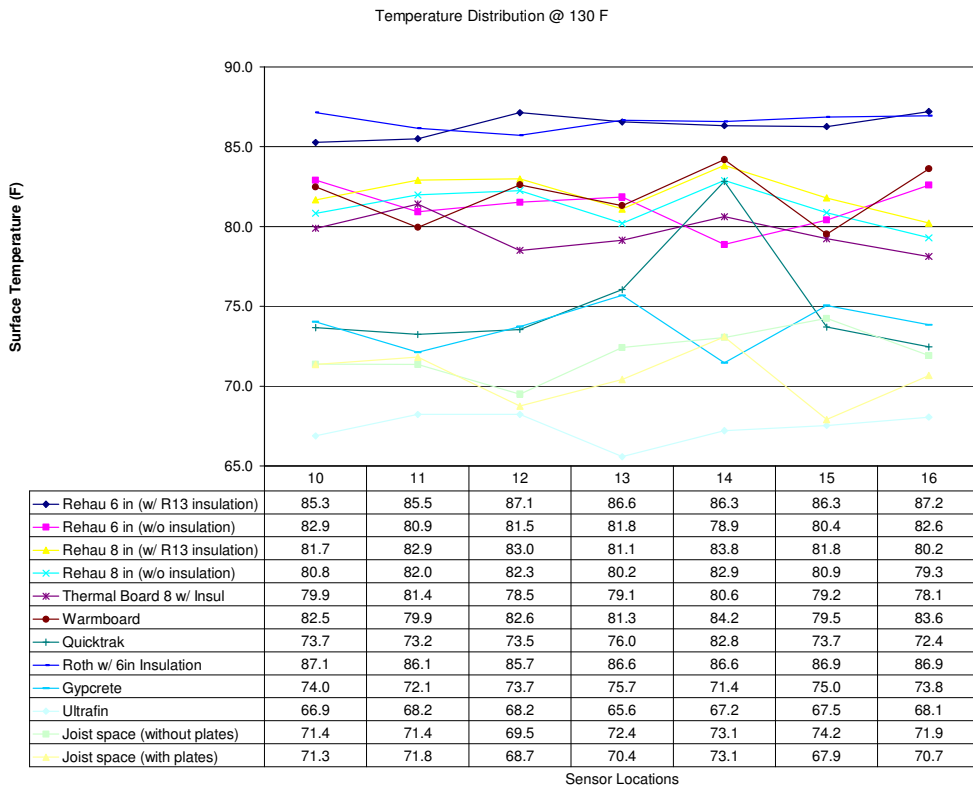

Graph 6-4: Surface Temperature Distribution Comparison at $T_{sw} = 130$ F

6-3 Hypothesis 3

A thermally stable system shows better energy performance based on supply and return fluid temperature readings.

Thermal stability of a radiant panel is studied as a measure of the fluctuations in surface temperature that occurs during the period of operation at a constant supply temperature. The paper analyses the stability by evaluating standard deviations for temperature readings for each sensor location along the central cross-section of test floor for each of the sample radiant heating panels.

- Raupanel 8” o.c (with & without insulation) and Quicktrak, with the lowest set of standard deviations performs best in this category. The average deviation from the average surface temperature at each sensor location along the central cross-section, stays under 0.5 F.

- Interestingly, Raupanel 6” o.c (with & without insulation) performs well under supply water temperatures of 100F and 110F but shows instability for 120F and over.
- As seen in the comparative graphs below, it is followed by Raupanel 6” o.c (w/o insulation) which stays under 1.0 F.

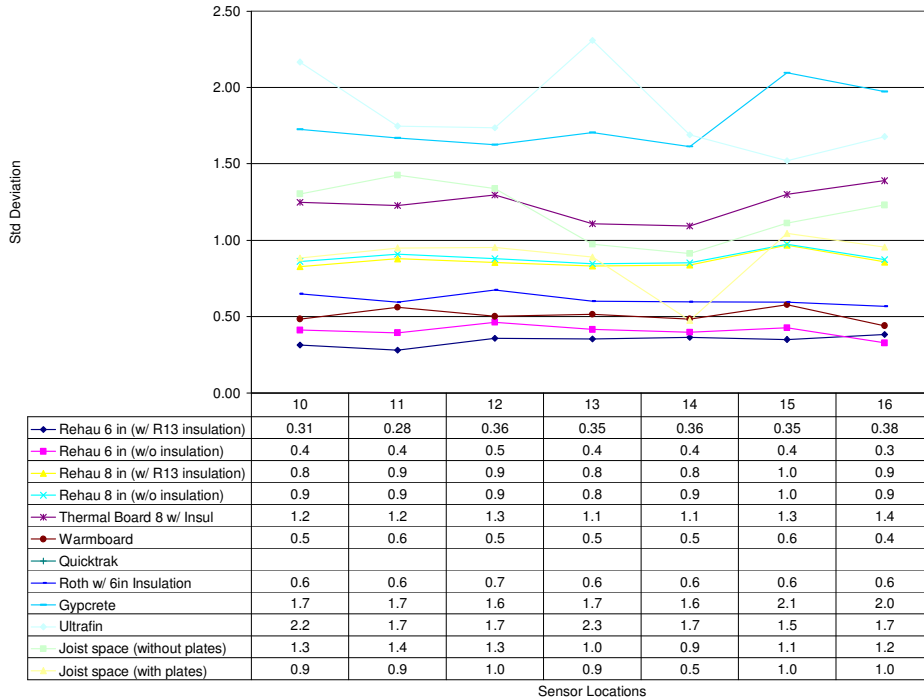

Graph 6-5: Stability Performance Comparison at $T_{sw}= 100$ F

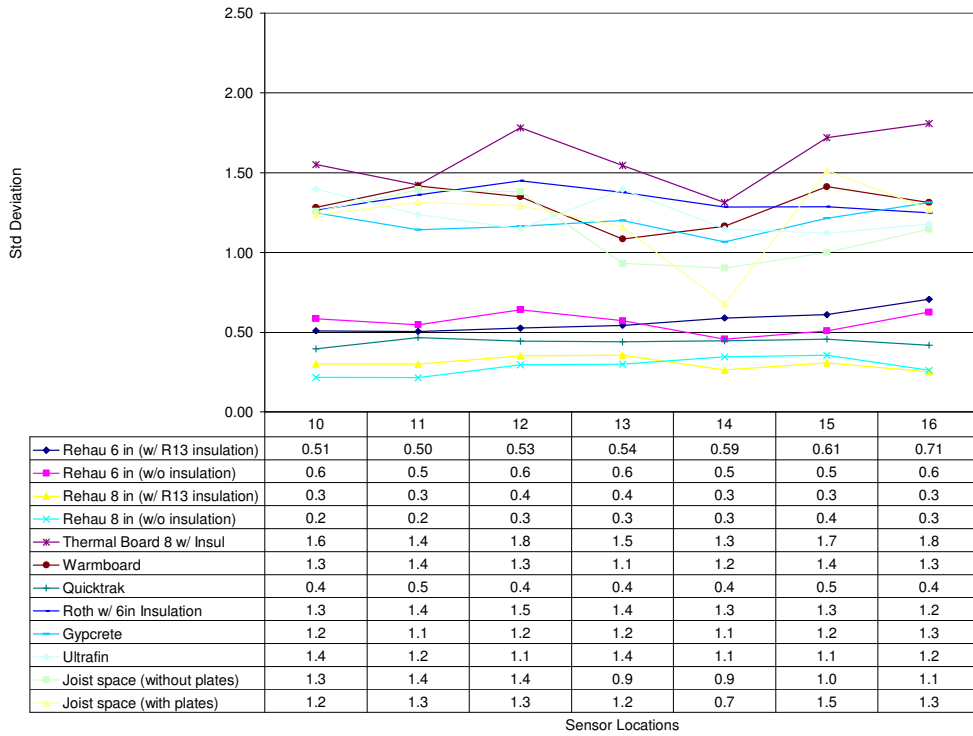

Graph 6-6: Stability Performance Comparison at $T_{sw}= 110$ F

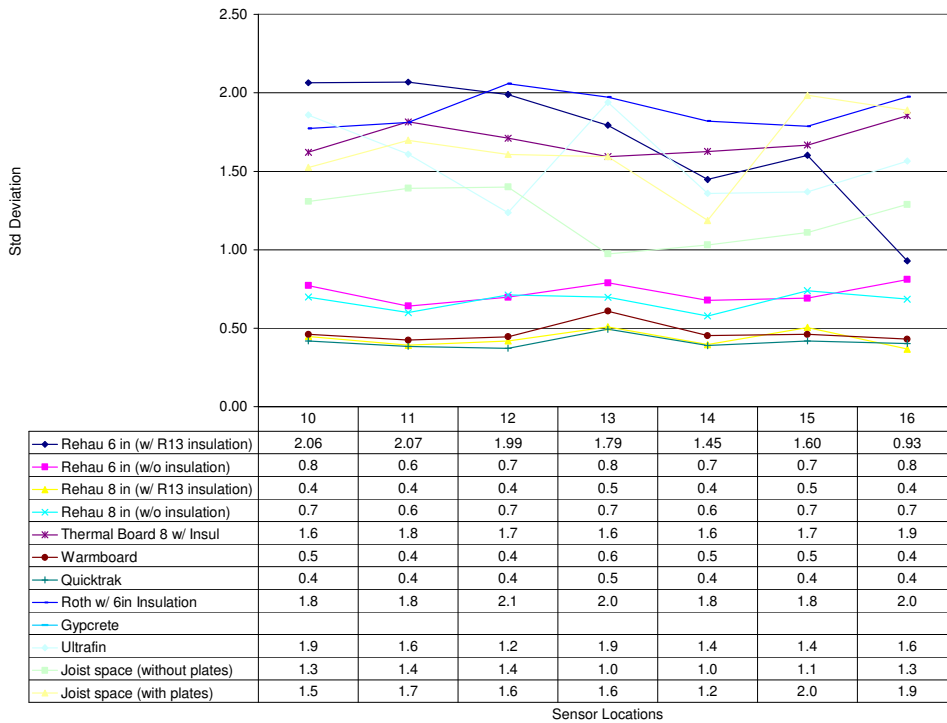

Graph 6-7: Stability Performance Comparison at $T_{sw}= 120$ F

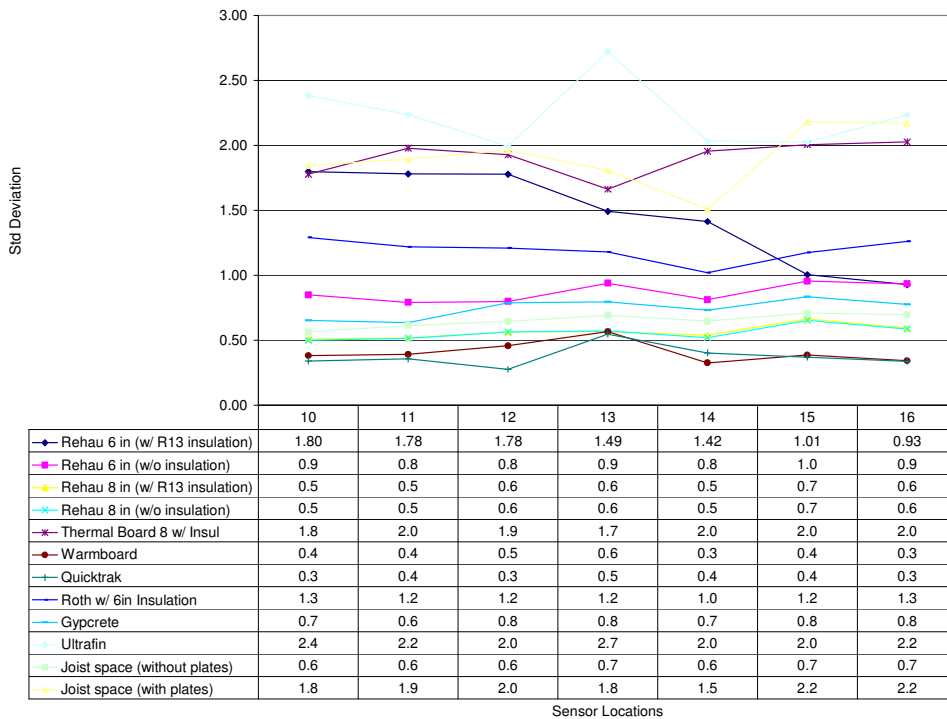

Graph 6-8: Stability Performance Comparison at $T_{sw}=130\text{ F}$

Surprisingly, Gypcrete with a larger thermal mass is not as stable as the other systems. There could be two reasons behind this unexpected behavior:

- a) Owing to a larger thermal mass, higher supply water temperatures may be needed for effective performance of the gypcrete system.
- b) Larger time duration for experiment may be needed to account for heavy thermal mass and consequentially higher response time.

Ultrafin performs as the least thermally stable system in the research. The standard deviations range between 1.3F and 2.8F corresponding to supply temperatures between 100F – 130F. Following could be reasons behind this behavior:

- a) Ultrafin requires large supply energy (supply water temperature) to perform effectively. Due to its design, it transfers limited heat to the floor above (achieving with low surface temperatures). The convective and radiative interaction with space elements has restrictive affect on the thermal performance of the floor panel.

- b) Since the metallic fins are not in direct contact with the floor finish, the distribution of heat transfer to the floor is not uniform or consistent.

In conclusion, it is found that there is no direct relation between thermal stability and thermal heat transfer performance of radiant floor heating systems. Quicktrak shows mediocre heat transfer to test floor system but shows strong thermal stability. Hence, this disproves the hypothesis.

VII. Limitations and Assumptions

Boundary conditions form an integral aspect of any experimental research initiative. While testing mechanisms and future standards can rate the performance of a radiant heating system with panels under given boundary conditions, the efficiency of the same system in a specific, but different, application is always difficult to determine. Like most testing procedures, the mechanism employed in this paper also has its limitations. It is imperative to look at the quantitative results in this research paper with knowledge of such limitations and corresponding assumptions. This chapter discusses these limitations and assumptions which may lead to constructive recommendations for future testing strategies. In these recommendations lies the true essence of the research.

7-1 Strong Convection Component

It is observed that there exists a strong convection component associated in the thermal interaction within the chamber. While the small air movement was introduced to fulfill indoor air requirement and to avoid overheating which could affect the performance of the system by introducing strong thermal inertia, the gradual increase in T_{air} is observed in all the systems (as shown in the graph below).

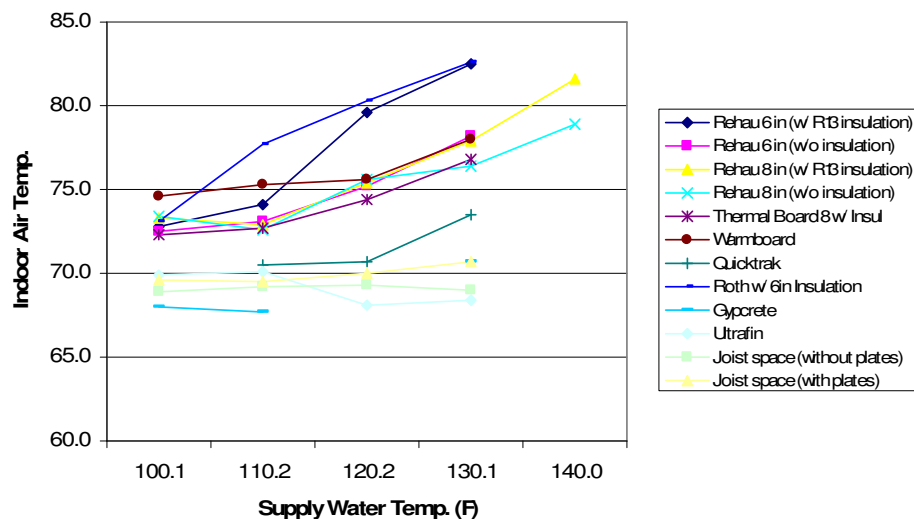

Graph 7-1: T_{air} variation under T_{sw} ranging between 100F – 140F

This could be attributed to two primary reasons:

- Due to lack of furniture/ obstructions, there is a strong interaction between airflow and radiant panel surface.
- Non- uniform airflow is suspected within the test chamber. It seems that the 4” x 4” exhaust diffuser (w/ louvers) was not able to perform efficiently as expected. It is suspected that this resulted in draft formation within the chamber gradually increasing the inside air temperature.

The above trend is observed in most radiant system samples with exceptions seen in ultrafin and joist space (with or without plates) radiant panels. This could be attributed to the low surface temperatures achieved by these systems during the experiment.

Assumption: Since, the air temperature is observed to be impacted by panel temperatures; the heat transfer is analyzed as a two-dimensional unsteady-state condition in the unit section perpendicular to the pipe. The convective component of heat transfer at the panel surface is evaluated while calculating the heat transfer potential of the system. (Refer chapter 5-2 for details).

7-2 Inconsistent Design Parameters

While the control parameters such as supply water temperature, fluid flow rate and supply air temperature are kept constant for all system models, design parameters like tube length may be different. Tube length is directly responsible for the amount of heat loss occurring in the system. However in relevance to the objective our testing mechanism, we compare the thermal performance over a constant area of application (32 square feet). This is in keeping with the understanding that the customer would be concerned about heat transfer per square feet.

7-3 Limitations of Thermocouples

Thermocouples are expected to sense temperature readings at the point of contact with the medium being measured. However, it is suspected that there has been a radiant exchange between the suspended upper ceiling thermocouples (esp. sensor 8/D2 measuring indoor air temperature) and the warm floor panel. It is recommended that the

perforated aluminum coated thermocouple be used to reduce/ avoid such undesired radiant exchange. Currently, we have used copper-Constantine.

7-4 Back Losses

Back losses form significant portion of heat loss in most radiant floor installations. Lack of thermal sensors readings for air and walls of the lower section chamber have limited our scope of quantifying back losses for each system.

7-5 Mixing valve

Supply fluid temperature is the most critical control parameter affecting heat loss. Manual mixing valve, as used in this research may have hampered the consistency of flow temperature which directly affects thermal performance. Manual mixing valve used in this research demanded constant attention since the return water temperature varied differently for each panel specification and with time variation. This affects the accuracy of the experiment.

7-6 Precision of Control Parameters

Thermal stability analysis is a measure of the time varied response of the radiant panel in response to the alterations in the transient conditions such as supply water temperatures, flow rate, and indoor air conditions. Due to budgetary constraints, the precision of control parameters in the test chamber is limited, which may inconsistently affect the response time of each panel.

VIII. Recommendations: *Contribution to future Testing Mechanisms*

While fulfilling commercial agreements with REHAU, the most significant contribution of this research has been towards identifying parameters (design and control) and boundary conditions in order to achieve a standard testing mechanism for evaluating thermal performance of radiant floors. The methodology adopted in this research was evolved in collaboration with the technical team of engineers from REHAU⁴. Having considered the role of various design and control parameters and setting boundary conditions, the experiment was performed for each of the 12 sample test devices.

While the performance of this testing mechanism may have been limited, the data gathered in the process has given us a comprehensive understanding of the parameters involved in the working of radiant floors. The observations of this research have guided us to formulate a set of recommendations which may form an effective tool of guidelines defining standard testing mechanisms for future testing.

8-1 Control Parameters

8-1-1 Uniformity in Airflow

It unquestionably agreed upon that minimal airflow must be introduced in the chamber to avoid oven-like affect which may unduly affect the thermal performance due to thermal inertia effects. However, as learnt from observations from the experiment, some guidelines must be carefully considered to ensure uniformity of airflow while designing the testing mechanism. Broadly, uniform airflow as referred to in this research is a condition when the supply and exhaust air flow rate are equal. This forms an important basis for creating a steady state system.

- Supply and exhaust air flow rates must be measured consistently to ensure uniform movement of air within the test chamber.
- Diffuser location should be as high above the floor so as to not unjustly affect the surface conditions.

⁴ Lance McNevin, John Kimball, Ernie Stevens - REHAU

8-1-2 Fluid Flow Temperature control

Automatic mixing valve must be used for the experiment. Supply fluid temperature is the most critical control parameter affecting heat loss. Manual mixing valve may hampers consistency of fluid temperature which directly affects thermal performance.

8-2 Design Parameters

8-2-1 Test Chamber Dimensions

Test Chamber dimensions must be worked out on the basis of the following recommendations:

- *The size of the test chamber must be evaluated to accommodate at least 2 side by side radiant panels from the system having the largest panel dimension of those being tested.* While the control parameters such as supply water temperature, fluid flow rate and supply air temperature are kept constant for all system models, design parameters like tube length may be different due to panel dimensions and tube spacing. Overall tube length is directly responsible for the amount of heat loss occurring in the system. Even though the performance is measured for the area of application, smaller test chambers may be disadvantageous for large panel systems that may perform well in specific applications. It is recommended to realize the system parameters and its application before working on the dimensions of the chamber.
- The inside dimensions must ensure uniform airflow and discourage draft formation.

8-2-2 Diffuser/ Grille Locations

Careful consideration must be given to supply/ return diffuser/ grille locations. Following recommendations must be considered:

- Supply air diffuser must be located such that the flow direction does not directly affect the performance of the radiant floor panel. It is recommended to be placed as high as possible from the test floor device.

- Supply air/ return air diffuser can be cross located to encourage uniform cross flow.

8-2-3 Test Chamber Insulation

Test Chamber must be well insulated (~ R17) to avoid any thermal interaction from the exterior.

8-3 Data Acquisition System

8-3-1 Thermal Sensors

- It is recommended that perforated aluminum coated thermocouples be used to reduce/ avoid undesired radiant exchange with radiant panel.
- Thermal sensors must be placed across the radiant floor panel on at least 2 locations.
- Thermal sensors must be placed at various heights at similar cross-sectional location as the floor sensors.
- Back losses form significant portion of heat loss in most radiant floor installations. To effectively study these losses thermal readings for lower chamber ceiling surface, lower chamber air temperature, and lower chamber wall surface temperature readings must also be recorded for quantitative analysis. The sequence must be the same as described in section 8-3-1-2 and section 8-3-1-3.
- Indoor air temperature readings must be measured 1' below the ceiling.
- Supply air and return air temperature readings must be recorded.
- Supply air and return air flow rate readings must be recorded.

References:

1. T. Napier Adlam, *Radiant heating*. Second Edition, The Industrial Press, New York, 1949.
2. Helmut E. Feustel, Personal communication, Lawrence Berkeley National Laboratory, June 1995.
3. John K. Manley, Editor, *Radiant heating, radiant cooling*. School of Architecture, Pratt Institute, 1954.
4. ASHRAE Standard 138-2005, *Method of Testing for Rating Ceiling Panels for Sensible Heating and Cooling*. American Society of Heating, Refrigeration and Air-Conditioning Engineers, Inc., Atlanta, 2005.
5. ASHRAE Standard 62-1989, *Ventilation for acceptable indoor air quality*. American Society of Heating, Refrigeration and Air-Conditioning Engineers, Inc., Atlanta, 1989.
6. <http://www.rehau-na.com>; REHAU- North America website, 2005.
7. Building & plumbing officials Bulletin.
8. Myoung Souk Yeo and Kwang Woo Kim; *A Study on thermal performance Simulation to Evaluate the Prefabricated Radiant Floor heating Systems*; Department of Architecture, Seoul National University.
9. John Siegenthaler, *Distribution Piping Options for Commercial Radiant Floor Heating*, PM Engineer, 2005.
10. www.radiantpanelassociation.org; Radiant Panel Association website, 2005.

AMIT KHANNA

Address: 350 Elan Village Lane, #113, San Jose, CA 95134

Phone: (540) 557-7970

Email: kahns@vt.edu

EDUCATION

M.S Architecture – *Buildings Sciences*, Virginia Tech, Blacksburg, VA. (2003-2005)

Bachelor of Architecture (Hons.), Indian Institute of Technology (I.I.T), Kharagpur, India. (1995- 2000)

EXPERIENCE

Graduate Engineer, Arup, San Francisco (August 2005 till date)

- Systems Integration, Energy Modeling, Life Cycle Cost Analysis.

Graduate Teaching and Research Assistant, Virginia Tech (Jan 2004 –August 2005)

- Assisting the instructor in grading homework and organizing study material for the senior class, "ARCH 5314- Environment Design and Sustainability"
- Assisting at the Research and Demonstration Facility (RDF) at Virginia Tech.

Lead Investigator for Energy Audit of 19 buildings at Petersburg National Battlefield, Petersburg, United States (June 2004- Aug 2004)

Sponsors: University National Park Energy Partnership Program (UNPEPP)

Manoj Joshi and Associates, New Delhi, India (July 2000- July 2003)

Tata Energy Research Institute (TERI), New Delhi, India (Mar 2002-July 2003)

Tata Energy Research Institute is India's premier institute in the field of energy and environment conservation. Consulted on the design and detailing of their campus buildings near Delhi, India.

- Architectural detailing of Earth Air tunnels
- Solar chimneys
- Waste Disposal network

Resident Architect, Sri Aurobindo Ashram, New Delhi, India (July 2000- Feb 2002)

Project Architect for 'Tapasya', a theme oriented building for the Delhi branch of Sri Aurobindo Ashram, a global charitable society doing pioneering work in various fields, notably education, philosophy, culture.

- Design and installation of thermosyphonic hot water system for Ashram involving over 260 solar thermal panels. (Cap. 26000 liter per day)
- Architectural and constructional detailing of conceptual design of the ashram building (built-up area- 80,000 sqft.)

PROFESSIONAL ASSOCIATIONS

- ASHRAE
- LEED™ Accredited Professional
- COA (Council of Architecture), India - Registered Architect in India.

SKILLS

Environments WINDOWS 98, XP, Macintosh.

Programming Languages C++

CAD and other Design Tools AutoCAD release- 14, 2000, 2002 and Photoshop.

Simulation Tools EnergyPlus V1-2, Power DOE V-1, DOE 2, Flovent V4.2 (CFD analysis), Energy-10, Climate Consultant, StatView 5.

ACADEMIC PROJECTS

- Solar Decathlon- Virginia Tech's official entry to the Federal sponsored competition at Washington DC, Oct' 2005. [Chief Energy modeler]
- Development and Demonstration of a Performance Test Protocol for Radiant Floor Heating Systems - M.S level research thesis and Industry Funded Initiative at Virginia Tech, Spring 2006. [Principal author]
- Petersburg National Battlefield Feasibility Study of Energy Improvements and Renewable Energy Applications - Federal Sponsored Initiative, Summer 2004. [Principal investigator]
- Building Integrated Photovoltaic Roof Membrane- Industry Funded Initiative, Summer/Fall 2004. [Team member]

PROFESSIONAL PROJECTS

- Environment & Energy Building - Stanford University, Palo Alto, California [Energy Modeling, LCCA, Systems Integration]
- Case Middle School, Punahou School [LEED Submission]
- Tata Energy Research Institute (TERI), New Delhi, India [Consultant Architect]
- Tapasya, Sri Aurobindo Ashram, New Delhi, India [Resident Architect]

AWARDS

- Trophy for the most creative Design, 1998-1999 at I.I.T- Kharagpur. (Day center).

ACTIVITIES

- Unit Secretary (1997-98) - Department of Architecture at Indian Institute of Technology, India.
- Captain of school table tennis team at State level Competitions. Individual ranking in Delhi State -15
- Playing lawn tennis, Trekking/ Camping.