

LD  
5655  
A761  
C48  
NO. 418  
VPI  
Spec

# The Child's Wardrobe

If a child has his own wardrobe, he can save his parents many steps. Here are suggestions to help in making or making over a wardrobe or closet to suit a small child. Actual measurements will be based on the space you have available; but drawers should not be so small or so few that they will not serve well.

In making the wardrobe, but together the sides, bottom, top, back, and inner wall first. Add shoe shelf. Put in drawer slides, drawers, and door. An oil finish is not as easily marred as varnish or enamel, will stand hard usage better.

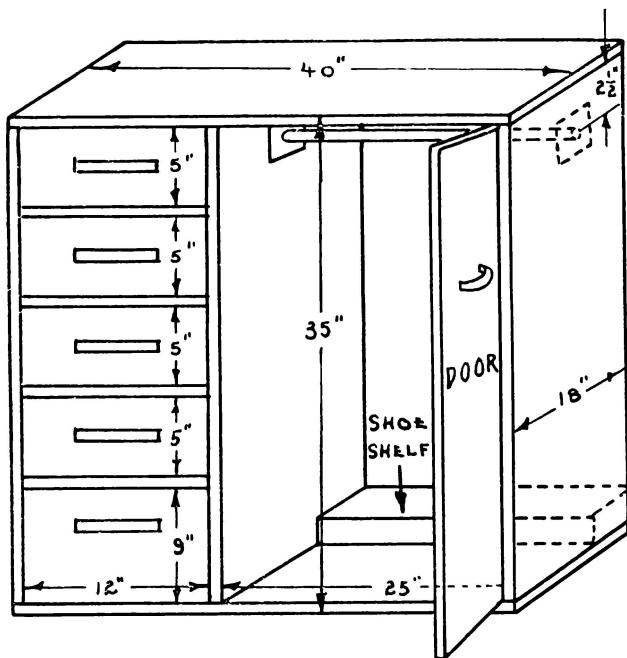

## Two-Step Stool

A stool like this one is easy to make. If of plywood, it will be light and easy to handle. It can serve as a seat while the child is putting on his shoes or playing with his toys, and as a step for reaching the wash basin or top of wardrobe.

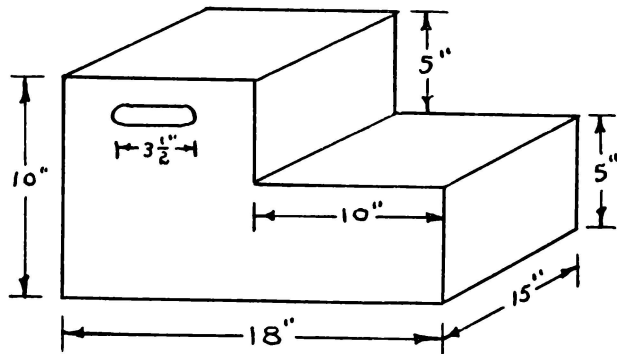

## Within His Reach

Here are several other suggestions for lowering hooks and rods in a full-size closet. The right-hand sketch below shows two boards, one with holes and the other with slots, to be nailed on

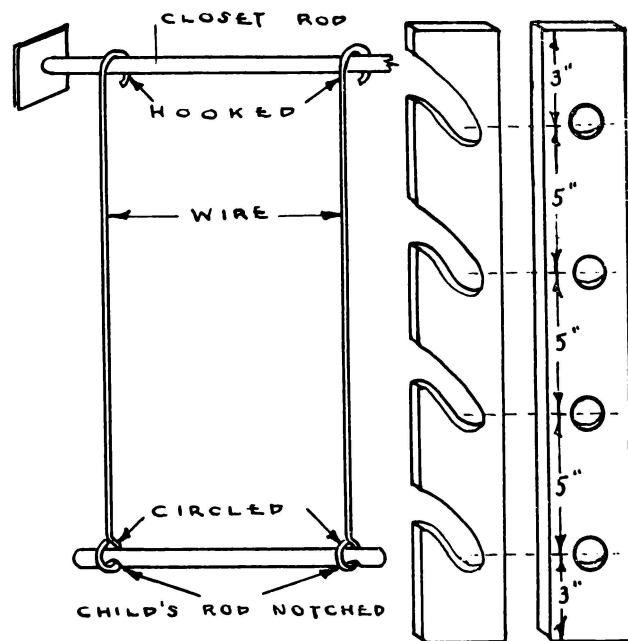

opposite sides of a closet. Use a broom handle for a rod. As the child grows taller, raise the rod to the next higher hole and slot.

