

THE HISTORY OF INDUSTRIAL ARTS IN THREE SELECTED
VIRGINIA PUBLIC SCHOOL DIVISIONS

by

C. Michael Harmon

Thesis submitted to the Graduate Faculty of the
Virginia Polytechnic Institute and State University
in partial fulfillment of the requirements for the degree of
MASTER OF SCIENCE
in
Education

APPROVED:

William E. Dugger, Jr., Chairman

E. Allen Bame

Mark Sanders

May, 1984

Blacksburg, Virginia

THE HISTORY OF INDUSTRIAL ARTS IN THREE SELECTED
VIRGINIA PUBLIC SCHOOL DIVISIONS

by

C. Michael Harmon

(ABSTRACT)

The history of industrial arts is rooted in the manual training movement, which began in the second half of the 19th century. Of the three school systems studied (Danville, Lynchburg and Richmond), Lynchburg was the first to offer manual training classes. Started in 1901, the classes were almost exclusively hand woodworking, and were taught at the secondary school level. In 1903, Richmond began offering manual training in its elementary schools. This program was first called industrial arts in 1921. Danville added industrial arts to its program of studies in 1929.

In the fall of 1929, the Virginia State Board of Education directed that non-vocational industrial education be promoted throughout the State. In the decade that followed, industrial arts programs in Danville, Lynchburg and Richmond grew to fill this directive. This period of growth was followed by almost 40 years of stagnation.

In June 1969, the State Department of Education created the Industrial Arts Education Service. Thomas Hughes was appointed to head this new division. Under his direction, the industrial arts curriculum throughout the State underwent many changes. These changes were

reflected in the renewed development of industrial arts programs in the three school systems studied in this paper. Today, these programs offer a wide variety of pre-technical and personal enrichment courses. As such, they serve both the general and vocational aspects of the schools' program of studies.

ACKNOWLEDGEMENTS

I would like to thank the following people for the time and effort they so graciously gave in helping me research this thesis.

, State Department of Education
 , Danville City Schools (retired)
 , Richmond City Schools
 , State Department of Education
 , Danville City Schools
 , Danville City Schools
 , Virginia Polytechnic Institute and State University (retired)
 , Lynchburg City Schools
 , Danville City Schools (retired)
 , Danville City Schools, Richmond City Schools (retired)
 , Lynchburg City Schools
 , Richmond City Schools
 , Danville City Schools (retired)
 , Montgomery County Schools
 , Lynchburg City Schools (retired)

Dr. Gustavus G. Williamson, Virginia Polytechnic Institute and State University
 , Lynchburg City Schools

I would also like to thank my wife for the time, patience, understanding and love that she put into consulting, editing

and typing this thesis. Without her help and support, it would surely remain unfinished.

TABLE OF CONTENTS

Introduction	1
Chapter	
1. From Manual Training to Industrial Arts, August 1891 - June 1929	4
2. Developing the Curriculum, September 1929 - May 1969 . . .	17
3. Restructuring the Curriculum, June 1969 - June 1983 . . .	29
Epilogue	45
References	49
Appendix A	51
Appendix B	52
Vita	53

INTRODUCTION

In Virginia's public schools, industrial arts is defined as the part of the general education program in which students learn about the many facets of our industrial and technological society. The learning experiences that comprise today's industrial arts program include creative thinking, problem solving and career education. Through these experiences, industrial arts seeks to help students become more responsible citizens by providing technical and consumer knowledge, and an understanding of how to productively use their leisure time.¹

Virginia's concept of industrial arts is the product of over 80 years of curriculum development, beginning with the manual training movement. This study will attempt to document the various stages in the maturation of the curriculum by reviewing the evolution of industrial arts programs in three Virginia public school districts: Danville, Lynchburg and Richmond.

The first step in gathering data on the Lynchburg and Danville programs was to contact the vocational supervisor in each city, advise them that this study was being undertaken, and ask for their help in obtaining information about industrial arts in their school system.

¹Thomas A. Hughes, Jr., George Swanik, III, Marshall O. Tetterton and Arvid W. Van Dyke, Industrial Arts Program of Studies (Richmond: Industrial Arts Education Service, Department of Education, 1978) p. 5.

In Danville, current and former industrial arts teachers and supervisors, and other educators, were identified and contacted. In telephone and personal interviews they provided a profile of the programs that were offered in that city as far back as 1929. In Lynchburg, School Board records dating back to the late 1800's were generously made available for inspection. Further information was provided by manual training and industrial arts teachers who were employed by the Lynchburg City Schools as early as 1925.

Research on the Richmond program began in the office of the State Supervisor of Industrial Arts, where information on that system had been gathered several years before. After this information was reviewed, former and current instructors and supervisors were contacted to verify the archival research. These gentlemen also provided their own insights into past and present instructional strategies.

Without a doubt, this research project would have been nearly impossible without the assistance of so many retired educators who played key roles in the early development of industrial arts programs in the school systems that were studied; written records of their successes and failures are virtually nonexistent. Indeed, it seems that this paper is the first attempt to collect their impressions and form them into a basis for describing the development of industrial arts curricula in Virginia. As Mr. Kurt Schneider, a former employee of both the Danville and Richmond City Schools, pointed out during one of our conversations, the opinions of old men are not often sought.

In the researcher's opinion, the collection of these insights into the development of industrial arts could be the most important contribution that this thesis offers today's practitioners. Hopefully, a review of the history of our profession will lead to a better understanding of the present industrial arts curriculum.

CHAPTER ONE

From Manual Training to Industrial Arts,

August 1891 - June 1929

The development of the industrial arts curriculum currently taught in Virginia and throughout the United States is rooted in the manual training movement, which began during the last half of the nineteenth century. The first American school to offer manual training courses was the Worcester Free Institute in Worcester, Massachusetts. Opened in November 1868, the Institute was "a technical school of about college grade; and the use of the shops and shop instruction was limited to those students in the course of mechanical engineering." John Boynton, the philanthropist who provided a \$100,000 endowment for the establishment of the Institute, described its mission this way: "The aim of this school shall ever be the instruction of youth in those branches of education not usually taught in public schools, which are essential and best adapted to train the young for practical life."¹

Other early manual training programs included woodworking for architecture students and ironworking for mechanical engineering students at the University of Illinois (1870), and shop facilities for engineering students at Washington University in St. Louis (1872).

¹Calvin M. Woodward, The Manual Training School (New York: Arno Press and the New York Times, 1969) p. 2.

The Manual Training School of Washington University offered one of the first manual training education programs for non-college students. It began providing instruction to boys 14 years and older in June 1879 under the direction of Calvin M. Woodward.

Eight years after the Manual Training School opened, Woodward explained the philosophy that led to the creation of the School in this way:

The object of the introduction of manual training is not to make mechanics. I have said that many times, and I find continued need of repeating the statement. We teach banking, not because we expect our pupils to become bankers; and we teach drawing, not because we expect to train architects or artists or engineers; and we teach the use of tools, the properties of materials and the methods of the arts, not because we expect our boys to become artisans. We teach them the United States Constitution and some of the Acts of Congress not because we expect them all to become Congressmen. But we do expect that our boys will at least have something to do with bankers and architects, and artists, and engineers, and artisans; and we expect all to become good citizens. Our great object is educational: other objects are secondary. That industrial results will surely follow, I have not the least doubt, but they will take care of themselves. Just as a love for the beautiful follows a love for the true, and as the high arts cannot thrive except on the firm foundation of the low ones, so a higher and finer development of all industrial standards is sure to follow a rational study of the underlying principles and methods. Every object of attention put into the schoolroom should be put there for two reasons - one educational and the other economic. Training, culture, skill come first; knowledge about persons, things, places, customs, tools, methods comes second. It is only by securing both objects that the pupil gains the greater prize, which is power to deal successfully with the men, things, and activities which surround him.²

As Dean of the University's polytechnic faculty, Woodward was

²Woodward, p. 229.

responsible for establishing the Training School's program of studies. He arranged the instructional program so that manual training took no more than half of the student's time. These studies included carpentry, wood-turning, pattern-making, ironworking, forging, brazing and soldering, and machining. English, Latin, science, mathematics, and drawing courses rounded out the school day.³

This was the status of manual training in the United States when, on August 1, 1891, the Superintendent of the Richmond (Virginia) City Schools recommended that a manual training program be introduced into that school division's curriculum. In his report, the superintendent noted that, while the city's efforts to develop a technical school for science and engineering students were important, there was also a need to provide an appropriate education for those students wishing to enter the "manual arts". As evidence of the need for such a program, the superintendent cited "the persistent presentation all over the country of the manual labor question" which he felt indicated "a popular need for manual training schools".⁴

Despite the Richmond superintendent's perception of the need for manual training programs, the Richmond City Council did not provide funding for these courses for another 12 years. During that time at

³Woodward, pp. 16-149.

⁴Annual Report of the Superintendent to the Richmond School Board, 1891, p. 14.

least one other school system began including manual training in its curriculum.

Lynchburg

In 1900, the Lynchburg City Schools established a committee to visit other school divisions and evaluate their manual training programs. The committee, composed of members of the School Board and the City Council, visited schools in "Washington and other eastern cities to inspect the work being done in Manual Training. Later the Superintendent of schools was authorized to visit several western cities for the same purpose."⁵

One of the concerns that the committee faced was which manual training philosophy to use as the basis for the Lynchburg program. The two most popular philosophies were the Russian system and the Sloyd system. In the Russian system, developed by Victor della Vos at Moscow's Imperial Technical School in 1868, each subject area was taught in a shop especially equipped for that purpose. He provided a work station for each student in the class, as well as a full set of tools appropriate for the subject being studied..

Students learned skills in a highly structured manner, beginning with simple projects and moving on to more complex assignments only when previous skills were mastered. In addition to being expected to produce more intricate projects as their skills improved, more ad-

⁵Francis A. Deyerle, Public Education and Public Schools of Lynchburg, Virginia, Jones Memorial Library, Vol. 2, p. 140.

vanced students were also expected to have less variance between the specified dimensions of their projects and the actual size of the object they produced. An important characteristic of this philosophy was that the projects made by the students did not necessarily have any value in and of themselves. The important thing was the skill that the student acquired in producing the assignment.

Regardless of the level at which they were working, all students studying under the Russian system worked from drawings, with one drawing being provided for each student. These drawings were made by students in the drawing classes.

In the Russian system, the background and training of the instructors employed to teach the students were a major concern. Proponents of the system felt that "Every teacher must have more knowledge of his specialty than is necessary merely to perform the exercises in the course of instruction. He must keep constantly in practice so that his work may be an example of perfection to his pupils." This dictum was based on the belief that "such dexterity increases the authority of the teacher."⁶

Olson has said that the Russian system "was revolutionary in that it employed a class type of training in contrast to the apprentice method."⁷ That the Russian system was unique is debatable, since the

⁶John L. Feirer and John R. Lindbeck, Industrial Arts Education (Washington, D.C.: Center for Applied Research in Education, Inc., 1964) pp. 7-8.

⁷Delmar Olson, Industrial Arts and Technology (Englewood Cliffs, N.J.: Prentice-Hall, 1963) p. 2.

Sloyd system was also not based on an apprenticeship system. Sloyd was designed to teach traditional handicrafts, and not to train students for employment in a specific trade.⁸

Like della Vos, proponents of the Sloyd philosophy believed that instruction should begin with simple concepts with which the student was already familiar. From this starting point, the instruction progressed to more complex material.

Quite unlike the Russian program, however, was the Sloyd philosophy that any and all projects should be useful to the student.⁹ Also, projects made in Sloyd programs were almost exclusively carved from wood. Thus, the course could be taught in almost any facility. These differences, and the fact that Sloyd training was not designed to provide specific vocational training, led to enormous practical differences in the implementation and scope of these two theories.

When Lynchburg opened its own program in the fall of 1901, it was the first system to offer manual training in Virginia's public schools.¹⁰ While there seems to be no hard evidence indicating which manual training philosophy the School Board adopted, it is known that

⁸Feirer and Lindbeck, p. 8.

⁹Feirer and Lindbeck, p. 10.

¹⁰Previous research by the Virginia Industrial Arts Association's History Committee found Richmond to be the first Virginia school division to offer manual training classes. The fact that this study was able to document an earlier manual training program indicates that a study of other school systems may be able to establish that they offered this program prior to 1901.

they hired a young Russian emigrant, Max Weber, to teach this new course to white students at the secondary school level. For his services, Weber was paid \$75.00 a month. According to the obituary that was printed in the Lynchburg newspaper after his death in 1961, Weber also taught at the University of Virginia's School of Methods when the Lynchburg schools were on their summer recess.¹¹

In 1903, Weber left Lynchburg to pursue a career as an artist.¹² His replacement, W. H. Reichus, resigned one year later. While the identity of Reichus' successor is not clear, it seems that the change in leadership had some impact on the curriculum. Shortly after Reichus' departure, the city purchased 1,000 Sloyd knives for use by the manual training students.¹³

In 1917, the Federal government began providing financial support for vocational education when the Smith-Hughes Act was signed into law. This Act was designed to provide funding for three categories of training: day classes for persons who had not yet entered the workforce, evening classes for workers who wanted to upgrade their skills, and part time classes.¹⁴

Spurred by the Smith-Hughes Act and its own success, Lynchburg's

¹¹Deyerle, pp. 192-193.

¹²Deyerle, p. 192.

¹³Personal interview with David Moseley, Supervisor of Vocational Education, Lynchburg City Schools, April 26, 1983.

¹⁴Merle E. Strong and Carl J. Schaefer, Introduction to Trade, Industrial, and Technical Education (Columbus, Ohio: Chas. E. Merrill Publishing Co., 1975), pp. 6-7.

vocational program expanded into many new areas during the next 25 years. By 1929, it included manual training (mainly woodworking), sewing and cooking, business (shorthand, typing, bookkeeping, and commercial arithmetic), and mechanical drawing.¹⁵ Despite this, the identification of an industrial arts course in Lynchburg was still many years away.

Richmond

When compared to Lynchburg, the Richmond City Schools moved quite rapidly from manual training to industrial arts. In 1903, "the [Richmond] City Council made an appropriation for the introduction of... elementary manual training into the public schools..."¹⁶

In the 1904-05 Superintendent's Annual Report, the progress of this new program was described: "At the beginning of the present session, the work was extended to include the first four grammar grades in the white schools and the first six primary grades of the colored schools. In February, we advanced to include all the colored primary grades, and in March we began work on our 5th grammar grade in the white schools."¹⁷

During that same year, a city-wide manual training curriculum was developed under the direction of Julian A. Burruss, who had been ap-

¹⁵Personal interview with David Moseley, April 26, 1983.

¹⁶Annual Report of the Superintendent to the Richmond City School Board, 1903-04, p. 11.

¹⁷Superintendent's Annual Report, 1904-05, p. 13.

pointed Director of Manual Training. The Superintendent's Annual Report went on to say "He (Burruss) has been indefatigable in his work, has outlined with the utmost care the detailed work of each grade, and has given the necessary instruction to the teachers."¹⁸

The Superintendent's comments on Burruss' work in training other teachers to teach manual training points out an unusual characteristic of the Richmond program: manual training was provided to elementary school children by their regular classroom teachers. The manual training personnel employed by the school system acted as curriculum planners and resource coordinators but did not actually teach the students. Since there was no attempt to provide this instruction under the direct supervision of a skilled craftsman, it cannot be said that Richmond fully adopted either the Russian or the Sloyd philosophies.

In December 1904, the Richmond City Schools displayed the projects completed by their students. This display was presented in conjunction with a conference centering on the theme "Industrial and Household Arts and Crafts". Burruss, in a June 15, 1905 letter to Richmond School Superintendent W. F. Fox, noted that similar projects made by students from "various (other) institutions and school systems..." were also displayed at the conference.¹⁹ Since Lynchburg and Richmond seem to have been the only Virginia public school systems offering manual training courses at the time of the conference, it is presumed that the

¹⁸Superintendent's Annual Report, 1904-05, p. 17.

¹⁹Superintendent's Annual Report, 1904-05, pp. 23-24.

other students were participating in similar programs at the Miller School in Albermarle County, and other private schools.

The December 1904 conference was important for two reasons. First, it allowed the public to view the results of the still new manual training programs. Second, and perhaps of even greater importance, the theme "Industrial and Household Arts and Crafts" shows that there was some movement towards the acceptance of the term industrial arts. It is unclear whether this development was inspired by Charles Richards' suggestion in the October 1904 issue of Manual Training Magazine that the name industrial arts be used to both unify and replace the terms manual training and manual arts.

As time went on, the Richmond programs began to include more and more students. During the 1905-06 school year, secondary students were able to receive manual training as a part of their program of studies.²⁰ This was the first time students outside the elementary schools were eligible for such training in Richmond.

In 1908, the School Board appointed Fred B. Hagaman Director of Manual Arts. (Manual arts was the new designation for what had been called manual training.) He saw a need for manual education as a part of the general education program, and expressed this view in the 1908-09 Superintendent's Annual Report: "It is my hope that in a few years all the training schools will be equipped with their own Manual Training rooms...". Hagaman went on to say "The work need not be vocation-

²⁰Superintendent's Annual Report, 1905-06, p. 11.

al...".²¹ In his 1911-12 Annual Report, the superintendent expanded this notion by implying that there could be an advantage in the separation of general manual training and specific vocational education when he wrote of the need to provide special skills to "boys who leave school at an early age".²² From this it would seem that the manual training/arts classes being taught at the time were of a more general than vocational nature.

In what was probably a continuation of this emerging philosophy of separate manual arts and vocational education programs, in 1914 the superintendent authorized the use of a survey prepared by the National Society for the Promotion of Industrial Education to help identify areas of the manual arts curriculum that needed improvement.²³ Then, in the 1918-19 Annual Report, Sarah A. Forbes signed a report from the Industrial Education Department.²⁴ Clearly, a non-vocational industrial education program had developed. Indeed, it appears that by 1921 courses in manual training, pre-vocational training, vocational training, and industrial education were all being offered. In light of this willingness to allow what had started as a small manual training program to grow to its full potential, it is not surprising that the 1921-22 Superintendent's Annual Report makes the first

²¹Superintendent's Annual Report, 1908-09, p. 30.

²²Superintendent's Annual Report, 1911-12, p. 22.

²³Superintendent's Annual Report, 1914-15, p. 22.

²⁴Superintendent's Annual Report, 1918-19, p. 113.

known mention of industrial arts as a specific course offering in Virginia's public schools, saying, "As now organized, the manual training or industrial arts work at the various schools is as follows...".²⁵

The following year, Forbes wrote:

We are gradually getting away from the idea that Industrial Arts is "making something". Realizing that it is a study of the changes through which materials must go to make articles useful to mankind, our teachers have taken their classes to visit the flour mills, the paper mills, the brick yard, the flower pot factory, the dairy farm, the truck farm, and other industries of our city... Many of the industrial plants sent samples of their wares in order that the children might have an exhibit of Richmond made goods.

Forbes then described how the industrial arts curriculum was being used to help students in their study of other subjects. In particular, she noted that industrial arts skills had been used by elementary students to make sand tables during their study of the history of Richmond. These sand tables depicted various stages in the development of the city.²⁶ Forbes then went on to say "This was all worked out by the pupils and it is needless to say that they know a bit more about their city now than when they started the project."²⁷

In 1923, Bonser and Mossman proposed a definition of the industrial arts curriculum that soon became the standard for describing these programs. They defined industrial arts as "the study of the

²⁵Superintendent's Annual Report, 1921-22, p. 69.

²⁶A sand table is very much like a shallow elevated sand box. By molding the sand and adding models of buildings, trees, etc., it is possible to create a display showing a given geographic area.

²⁷Superintendent's Annual Report, 1922-23, p. 72.

changes made by man in the forms of materials to increase their values and of the problems of life related to these changes". The impact of this definition, and a growing awareness of the non-vocational nature of industrial arts, is illustrated by the 1926-27 Richmond industrial arts curriculum, shown in Appendix A.²⁸ The program was seen primarily as preparing students for entry into one of the city's three high schools (vocational, technical or academic).

At the start of the 1929-30 school year, the Virginia State Board of Education directed that its staff undertake a program to promote non-vocational industrial education in the State's public schools. Spurred by this directive, industrial arts entered into a new phase of curriculum development and expansion throughout the State.

²⁸Superintendent's Annual Report, 1926-27, p. 63.

CHAPTER TWO
Developing the Curriculum,
September 1929 - May 1969

At the time of the Virginia State Board of Education's decision to encourage the development of non-vocational industrial education courses, Benjamin Van Oot was the State Supervisor of Trade and Industrial Education. As such, he was the administrator responsible for implementing the Board's directive. One of his first acts was to recruit six graduates of his alma mater, Oswego Normal School in Oswego, New York, to teach industrial arts in Virginia. These six instructors were hired for the 1930-31 school year.¹

Lynchburg

Having secured a core of industrial arts professionals, Van Oot next moved to increase the number of industrial arts courses taught in the Commonwealth. As he reviewed the status of non-vocational industrial education throughout Virginia, Van Oot saw that Lynchburg was still offering only a very limited manual training program. To both remedy this situation and help enforce the State Board's directive, he proposed that Lynchburg "reorganize the shop work... on a general shop basis" and offer two additional shop classes. In return for this re-

¹Personal interview with Tom Hughes, State Superintendent of Industrial Arts Education, November 12, 1982.

vision of their program, Van Oot promised to reimburse the city in the amount of \$1,000 for each full time shop teacher employed by the school system.²

The Lynchburg School Board considered this proposal at its April 10, 1931 meeting. During the discussion of Van Oot's offer, board member H. H. Harris pointed out that, by accepting Van Oot's terms, the city would be able to hire three teachers for less than it cost to pay the full salaries of two instructors. The board then voted to accept the proposal, effective September 1931.³ Under a similar arrangement, the State provided two-thirds of the instructor's salary when a non-vocational night class for "some twenty young Negro men" was established in Lynchburg in 1932.⁴ In this one system, then, Van Oot had encouraged the creation of two new positions in only two years.

During the next decade, very few changes occurred in Lynchburg's manual training program, which was almost exclusively hand woodworking. Indeed, the next major development was the introduction of power equipment in 1948. With this equipment, the schools were able to do a more credible job of providing students with employment skills. As a result, by the early 1950's Lynchburg's manual training courses had developed into a purely vocational curriculum. To fill the gap created by this change, a program specifically designated as industrial arts

²Deyerle, Vol. 5, unpaginated.

³Deyerle, Vol. 5, unpaginated.

⁴Deyerle, Vol. 5, unpaginated.

was added to the program of studies in 1958.

Like their vocational programs, Lynchburg's new industrial arts courses were organized as unit shops. The unit shop concept dictated that students study only one subject area (for example, woodworking) in a facility designed especially for that purpose. The similarity between the city's industrial arts and vocational courses served to blur much of the distinction between the two departments.⁵ As a result, another decade passed before the distinction in these programs clearly re-emerged.

Danville

Of course, Lynchburg was not the only school division in which Van Oot sought to enforce the State Board of Education's directive. In Danville, he found a newly established industrial arts woodworking program being offered at Robert E. Lee High School under the direction of Grover Tome. In January 1931, Kurt Schneider was hired to teach auto mechanics, a course that was included in the industrial arts curriculum. The year after he arrived, Schneider also started an electricity and electronics class, and a small print shop was added into the program. The industrial arts department achieved some school-wide recognition when a large platen press was donated to the school and students in the industrial arts department began producing a school newspaper. But, according to Schneider, it was an assembly program

⁵Telephone interview with Norvell White, former manual training teacher in the Lynchburg City Schools, May 10, 1983.

that truly launched industrial arts as a vital part of the school's program of studies.

In the mid-1930's, school policy at Robert E. Lee required that each department conduct an assembly describing its curriculum to the remainder of the school. Schneider recalls that most of the programs that were presented were fairly dry. To enliven the industrial arts assembly, the instructors agreed to concentrate on the powers of electricity, including wands that set paper on fire, devices that shot sparks across the stage, and generators that made a person's hair stand on end. The following year, industrial arts enrollment soared, and a tradition was born.⁶

In 1936, James Van Oot, nephew of Benjamin Van Oot, graduated from Oswego and accepted an industrial arts teaching position in the Danville system. When he arrived, the program had grown to include courses in general woodworking, general metalworking, electricity, printing, drafting, and auto mechanics. Each of these programs was taught as a unit shop course.

At the junior high level, where industrial arts was mandatory for all boys, students rotated through a series of unit shops during the school year. Either 6, 9, or 18 weeks was spent in each shop, depending on the student's grade level and the industrial arts course he was taking. In this way, students were able to sample a variety of industrial processes.

⁶Telephone interview with Kurt Schneider, April 7, 1983.

At the high school level, courses were arranged so that the student studied a single area (for example, metalworking) in a unit shop for the entire school year. At this level, industrial arts was seen as being preparatory for entry into a vocational program, and/or as supplementing academic studies by providing a practical application for the theories learned in math, science and other areas.⁷

It seems then, that Danville developed a more sophisticated distinction between vocational training and industrial arts than was found in Lynchburg. Even so, the industrial arts programs and instructional strategies that James Van Oot found in place in 1936 remained in use well into the late 1960's.

Richmond

While the Lynchburg and Danville systems remained relatively inert, the Richmond program was changing. In 1945, vocational/industrial education in the city was placed under the direction of Kurt Schneider, who had left Danville in 1936. As Director of Vocational Education, Schneider first changed the industrial arts curriculum from being almost exclusively woodworking and mechanical drawing into a near mirror image of the Danville program. Over the next twenty years, he sought to reinforce what he felt was the basic strength of the industrial arts philosophy: the notion that industrial arts was uniquely capable of providing students with an opportunity to study their industrial envi-

⁷Telephone interview with Hosmer Allyn, former industrial arts teacher in the Danville City Schools, April 5, 1983.

ronment, and at the same time develop and expand their own creative and problem solving abilities.

The pamphlet, "Organization and Curriculum of the Industrial Arts Education", published by the Richmond City Schools shortly before Schneider's retirement in 1966, described the program that had been created in that school system.

One of Schneider's objectives for industrial arts was to have it in place, but barely recognizable, in the elementary schools. At this level, it was stated, industrial arts "best achieves its objectives by the loss of its own identity." The purpose of these programs was to allow students to experiment, on a very basic level, with materials and processes that related to industry. These experiences took place in a "resource room" which was available to any regular classroom teacher who wished to use it. The materials that were available included wood, paper, clay, and glue. The activities that were to be examined included "homemaking, care of the sick, cooking, sewing, decorating, art work, modeling, printing, cleaning, scrubbing, sawing, hammering, building, taking apart, putting together, working alone, working together, etc., etc."⁸

According to Schneider, this was an area where industrial arts had an almost limitless potential. The execution of the concept, however, proved to be a failure. Schneider saw this failure as the re-

⁸William Eister, "Organization and Curriculum of the Industrial Arts Education" (Richmond: Richmond City Schools), pp. 4-5.

sult of two factors. First, he felt that the facilities were under-used, and attributed this to the elementary classroom teachers being unwilling to venture into an unstructured learning experience. Second, and perhaps more important, was the resistance to this program that came from the art supervisor. She reportedly felt that the resource rooms infringed on her area of authority, and instructed those few elementary teachers who were using the facility to not use it anymore. According to Schneider, these two events ended industrial arts at the elementary school level in Richmond.⁹

At the secondary school level, industrial arts sought to provide a "broad general education" by introducing students, both boys and girls, to various industrial tools, materials and processes. The development of good working skills and pride in one's achievements were major goals of the program. The subjects studied included "woods, metals, plastics, synthetics, textiles, ceramics, etc., and processes such as depicting, designing, forming, assembling, fabricating, finishing, etc.".

Another goal of industrial arts at the secondary level was to provide students with "a sound foundation for intelligent occupational choice", and "some degree of competence desirable for initial employment". It was stressed, however, that industrial arts was not to be considered a vocational program. Students seeking specialized job

⁹Personal interview with Kurt Schneider, June 21, 1983.

training were referred to other courses.¹⁰

Industrial arts programs in Richmond also differed from those in Lynchburg and Danville in that they were taught in general shops. Unlike unit shops, these facilities were designed to allow many different types of processes (for example, woods, metals, and plastics) to be taught at the same time, in the same room. The first year of the industrial arts program allowed students to study the history and industrial applications of such diverse topics as drawing, woodworking, graphic arts, ceramics, leatherworking, and textiles. In the second year course, students explored metalworking, electricity, plastics and power mechanics.

Students who showed a special interest in specific areas were, with their instructor's permission, allowed to take a third, and even a fourth year of industrial arts. In addition to studying industrial arts at an advanced level, these students were also responsible for establishing and maintaining a personnel system. Classroom management was carried out through this student-run organization.¹¹

While Lynchburg's industrial arts and vocational programs were quite similar, teachers and administrators in Richmond and Danville emphasized the exploratory nature of industrial arts. In these two cities, the program was designed to allow students to explore a wide variety of industrial materials and methods.

¹⁰Eister, pp. 6-8.

¹¹Eister, pp. 10-12.

In 1946, the concept of industrial arts as an exploratory curriculum received long-term reinforcement when Joseph A. Schad was selected to head the newly formed Industrial Arts Department at Virginia Polytechnic Institute (VPI). Schad came to this post well versed in the industrial arts philosophy prevalent in Virginia at the time. A graduate of Oswego Normal School, he was one of six original industrial arts teachers brought to the State by Benjamin Van Oot in 1930. It is not surprising then, that Schad created a teacher education program based on the notion that industrial arts should help students identify their own area(s) of interest.¹² By providing teachers who were both technically and ideologically prepared to implement this notion, VPI became an important factor in further solidifying industrial arts as the area of the school curriculum that was responsible for non-vocational industrial education.¹³

Several professional publications released during the 1950's and early 1960's indicate that Schad's philosophy was not out of step with national trends in industrial arts. One of these publications, prepared by the American Vocational Association (AVA), established certain organizational recommendations for industrial arts at the elementary, junior high and senior high school level. These recommendations echoed Schad's philosophy. They also bear a striking resemblance to

¹²Personal interview with Russell G. Louis, former industrial arts professor at Virginia Tech, May 24, 1983.

¹³Personal interview with Tom Hughes, July 27, 1983.

the concepts Schneider used in building the Richmond program.¹⁴ At the elementary level, according to the AVA, industrial arts should enrich the general education program, "contribute to the personal development of the child", and "acquaint him with his environment".¹⁵

At the junior high school, industrial arts was seen as an "essential part of the basic education program for both boys and girls". Through well-organized, wide ranging classroom and laboratory experiences, the AVA felt that these students should be provided with "an understanding of their own interests, abilities, limitations and opportunities...".

Consumer education was also seen as a function of industrial arts at this level. Projects were viewed not as an end in themselves, but as a method of developing all of these aspects of the child's awareness, as well as teaching leisure-time skills. Suggested topics included drawing, woodworking, metalworking, power mechanics, graphic arts and craft work.¹⁶ At the senior high level, the AVA recommended a program that would "assist materially in a gradual but sound ap-

¹⁴It was suggested by a member of the Richmond Central Office Staff that the recommendations published by the AVA were "borrowed" from Richmond's "Organization and Curriculum" booklet. Regardless of the veracity of such a claim, the fact that both groups came to use almost identical language seems to support the validity of the concept each was espousing.

¹⁵American Vocational Association, Industrial Arts Education, (Washington, D.C.: AVA, n.d.) p. 5.

¹⁶AVA, p. 6.

proach to some form of specialization in a major area."¹⁷

With a firm philosophical base to guide its growth, industrial arts began attracting more and more students. And, as the curriculum became an established part of public education in Virginia, many industrial arts teachers began to participate in the Council of Industrial Education Clubs, an organization sponsored by the State Department of Education and designed to serve both industrial arts and trades and industries teachers. During the next decade, many industrial arts teachers began to feel the need to form a separate industrial arts organization to help instructors deal with issues and problems specifically relating to their field.

In 1957, a group of twenty-two teachers and teacher educators from around the State, "organized to establish a separate organization solely for the purpose of serving the Industrial Arts profession". The Virginia Industrial Arts Association (VIAA) was organized in Richmond on May 17, 1958, and conducted its first annual meeting in October of that same year.

At subsequent meetings, industrial arts scholars were invited to address the changes that were beginning to occur in the philosophical base that supported the industrial arts curriculum. In response to these changes, the VIAA proposed in May 1962 that the State Department of Education remove the responsibility of overseeing industrial arts

¹⁷AVA, p. 6.

programs from the Trade and Industries Supervisor, and create the position of State Supervisor of Industrial Arts.¹⁸ Seven years later the recommended separation of industrial arts and vocational education took place, and Virginia's industrial arts programs entered into a new phase of development.

¹⁸John Frank, Thomas Hughes, and Chester Lane, The Virginia Industrial Arts Association, 1958-1978, (Virginia Industrial Arts Association, 1978), pp. 3-10.

CHAPTER THREE

Restructuring the Curriculum,

June 1969 - June 1983

In June 1969, the Virginia State Department of Education created the Industrial Arts Education Service. This new division was given the responsibility for statewide supervision of industrial arts programs. Prior to 1969, this function had been carried out by industrial arts specialists working under the Supervisor of Trade and Industrial Education.

The creation of the Industrial Arts Education Service is largely credited to the lobbying efforts of the Virginia Industrial Arts Association. According to Tom Hughes, the industrial arts specialist appointed to head the new division, Joseph Schad of Virginia Polytechnic Institute was the driving force behind this lobbying effort.¹

In 1970, Hughes and Marshall O. Tetterton, Assistant State Supervisor for Industrial Arts, released the division's first publication. Entitled Industrial Arts for the Seventies, it described industrial arts as a program through which students gain an "insight and understanding of the technological nature of the (American) culture."²

¹Personal interview with Tom Hughes, July 27, 1983.

²Thomas A. Hughes and Marshall O. Tetterton, Industrial Arts for the Seventies, (Richmond: Industrial Arts Education Service, Department of Education, 1970), p. 1.

To achieve this goal, industrial arts courses were seen as encompassing five major curriculum areas: Manufacturing, Construction, Communications, Power and Transportation. Each of these courses was seen as being "unique and independent of previous or subsequent courses".³

In Hughes' view Industrial Arts for the Seventies served as a "springboard" for all subsequent industrial arts curriculum revision in Virginia. It provided, for the first time, a discussion of how a contemporary curriculum could be created to replace industrial arts programs that had, in some cases, remained unchanged for several decades.

At about this time, the Industrial Arts Education Service also revised its priorities. Rather than being a source of new curriculum concepts, the Service was reorganized to act as an agent for implementing some of the ideas that were being developed across the nation. According to Hughes, three of these programs influenced the industrial arts curriculum in Virginia. These were the Maryland Plan, the Industrial Arts Curriculum Project, and the American Industries Project.⁴

The first of the innovative programs to be introduced into Virginia's public schools was the Maryland Plan, created by Donald Maley at the University of Maryland. It was designed for use at the seventh, eighth and ninth grade levels. Under this program, seventh grade students used the unit approach to studying industrial arts. The three

³Hughes and Tetterton, p. 3.

⁴Personal interview with Tom Hughes, July 27, 1983.

units that Maley recommended for study were tools and machines, power and energy, and communications and transportation. Learning experiences include the completion of individual projects in each of these areas.

The eighth grade program emphasized a group-process approach to learning. Here, students selected an industry and made an extensive study of that field. This study included a mass production exercise and the construction of a display explaining the processes used in the industry being explored.

The ninth grade program was designed to be a culminating industrial arts experience. Here, instruction was designed to provide for the students' interests, aspirations, capabilities, and problem-solving skills. Thus, the type of instruction provided is seen as varying from group to group.⁵

A second innovative program, the Industrial Arts Curriculum Project (IACP), was developed at Ohio State University during the mid-1960's. James Buffer, Professor of Education at Ohio State University, noted that "the general purpose of the Industrial Arts Curriculum Project was to effect curriculum change in industrial arts education".⁶

⁵Donald Maley, The Maryland Plan, (New York: Benzinger, Bruce and Glencoe, Inc., 1973).

⁶James Buffer, "Industrial Arts Curriculum Project - Past, Present and Future", Curriculum Projects, (Washington, D.C.: AIAA, 1973), p. 28.

To bring about this change, six steps for the development and implementation of the IACP were identified by its authors. The initial steps included determining what information should be included in the industrial arts curriculum, and developing a syllabus for its presentation. The syllabus was then developed into a set of teaching materials including a text book, laboratory manual, and teacher's guide. This was followed by extensive field testing and revision of the materials. Finally, the revised materials were distributed and in-service training programs for industrial arts teachers in the field were begun.⁷

One of the major contributions of the IACP was the production of the teaching materials needed to implement the "World of Manufacturing" and "World of Construction" courses.⁸ Both of these courses were designed to provide junior high school students with a broad exploratory experience in the areas they covered.

The American Industries Project was developed at Stout State University, Wisconsin. In this program, industry is defined as "an institution in our society which, intending to make a monetary profit, applies knowledge and utilizes natural and human resources to produce

⁷Buffer, pp. 28-31.

⁸Daniel Householder, Review and Evaluation of Curriculum Development in Industrial Arts Education, (Bloomington, Ill.: McKnight Publishing Co., 1972), p. 18.

goods or services to meet the needs of man".⁹ The authors of the American Industries Project based their program on the study of 13 basic concepts they identified as being essential to understanding industry. They are "communication, transportation, finance, property, research, procurement, relationships, marketing, management, production, materials, processes, and energy".¹⁰ These concepts form the basis for instruction under this system.

Using an implementation strategy very similar to the one developed by the authors of the IACP, the Industrial Arts Education Service began providing for in-service teacher training in these programs. Taught not by State Department or university personnel, but by classroom teachers who were successfully using these techniques, the seminars reached 700 of the State's 900 industrial arts teachers between 1969 and 1972.

With retrained teachers available to put these programs into the schools, Hughes and his staff began working with local divisions to provide adequate instructional facilities and supplies. Additionally, various curriculum councils composed of State Department supervisors, teacher educators, local school personnel and representatives of the Association of General Contractors and the Virginia Manufacturer's Association assisted in the acquisition of the materials needed by in-

⁹Harry Olstead, "American Industry: A New Direction". Curriculum Projects, (Washington, D.C.: AIAA, 1973), p. 9.

¹⁰Olstead, p. 9.

structors to successfully teach the newly implemented programs. At the same time, teacher education programs in Virginia were changed to insure that graduates would be capable of presenting these new courses.¹¹ These changes included the presentation of pre-service and in-service courses in the World of Manufacturing and World of Construction at Virginia Tech, Virginia State University, Old Dominion University and Norfolk State University.

In addition to changing the industrial arts curriculum, Hughes and his staff also sought to include co-curricular activities in the program of studies. In 1970, the Virginia Chapter of the American Industrial Arts Student Association (AIASA) was formed. AIASA was designed to be an integral part of all industrial arts courses. An objective of the Association is to help students "develop leadership qualities as well as high standards of craftsmanship, scholarship and safety".¹²

Despite the efforts to promote IACP, Maryland Plan and American Industries Project courses, there was no guarantee that local school systems would accept the curriculum changes that the State Department of Education was advocating. In Virginia, school divisions are free to establish their own program of studies, provided that they do not contradict State law. Thus, Hughes and his staff found themselves in

¹¹Telephone interview with Tom Hughes, October 31, 1983.

¹²The Industrial Arts Curriculum, K-12, 2nd Edition, (Richmond: Industrial Arts Education Service, State Department of Education, 1980), p. 13.

the position of salesmen, working to convince school systems to accept the changes they were trying to bring about.¹³

In 1973, State funding for certain approved industrial arts courses, administered through the State Department of Education, was the primary tool available to Hughes in his efforts to sell the new concept of industrial arts to local school divisions. At this time, the funded courses included World of Manufacturing, World of Construction, Modern Industries and Technology and Exploring Technology.¹⁴ By September 1979, funding had been expanded to include 15 courses.¹⁵ These courses are listed in Appendix B.

Lynchburg

In 1969, Lynchburg's industrial arts program consisted mainly of woodworking, metalworking, drafting and electronics courses taught at the junior high school level. Seventh grade students studied industrial arts for one semester, with the time being equally divided between each of the four areas. Eighth grade students were offered a full year of industrial arts instruction, with nine weeks spent studying each topic. Ninth grade students selected one area, and spent the

¹³Personal interview with Tom Hughes, July 27, 1983.

¹⁴The Industrial Arts Curriculum, K-12, 2nd Edition, (Richmond: Industrial Arts Education Service, State Department of Education, 1977), p. 16.

¹⁵Telephone interview with Marshall Tetterton, Assistant State Supervisor of Industrial Arts, May 15, 1984.

entire year studying only that phase of the program. To accomodate this structure, a unit shop approach was used throughout the program. While the seventh grade course was mandatory for all students, the eighth and ninth grade classes were offered as electives.¹⁶

In Lynchburg, industrial arts traditionally filled a pre-vocational, exploratory role. Thus, in 1969 there was only one industrial arts course offered beyond the ninth grade - a woodworking/carpentry class at Dunbar High School. All other high school industrial education courses were purely vocational. These courses included auto mechanics, building trades, cabinetmaking, commercial sewing, drafting, electricity, industrial cooperative training, machine shop, maintenance and repair, metals, and woodworking (carpentry).¹⁷

In 1970, the Lynchburg City Schools were racially integrated for the first time. As a result of this change, the School Board abandoned its traditional elementary (K-6), junior high (7-9) and high school (10-12) approach to education. Instead, students spent two years (grades 7 and 8) at either Sandusky or Robert E. Lee Junior High School, two years (grades 9 and 10) at Dunbar High School and two years (grades 11 and 12) at E. C. Glass High School. Despite this, the nature of the seventh and eighth grade programs remained unchanged. At Dunbar, metalworking was dropped from the curriculum, and

¹⁶Telephone interview with John Scott, industrial arts teacher, Lynchburg City Schools, December 2, 1983.

¹⁷State Department of Education records, 1969.

tenth grade students were allowed to participate in industrial arts programs for the first time. There were no industrial arts courses taught at E. C. Glass.¹⁸ The industrial arts curriculum retained this format for four years.¹⁹

During the 1974-75 school year, Lynchburg began teaching the World of Construction and World of Communications. These courses were offered as a supplement to, and not in place of, the unit laboratory classes available at the ninth and tenth grade level.²⁰ The implementation of these courses was strongly encouraged by the Industrial Arts Education Service.²¹

In 1977, Lynchburg opened a second high school, Heritage, and moved to its current elementary (K-5), middle (6-8) and high school (9-12) format. These changes led to an increase in instructional space available within the various buildings. The industrial arts program responded by dramatically increasing its offerings during the late 1970's. Indeed, by the start of the 1980-81 school year, ten industrial arts courses were being offered throughout the city. Of these ten courses, nine were being partially funded by the Industrial Arts Education Service: Communications Technology, Electricity and

¹⁸Telephone interview with John Scott, December 2, 1983.

¹⁹Letter from Henry Wyatt, industrial arts teacher, Lynchburg City Schools, December 6, 1983.

²⁰Letter from Henry Wyatt, December 6, 1983.

²¹Telephone interview with John Scott, December 2, 1983.

Electronics Technology, World of Construction, Basic Technical Drawing, Engineering Drawing, Graphic Communications, Exploring Technology (18 and 36 week course) and Industrial Occupational Exploration. The tenth course, photography, was only taught at E. C. Glass High School. At the same time, the traditional unit shop courses were phased out of the curriculum.

In September 1982, the industrial arts program was further expanded to include the courses Electronics Technology, Graphic Communications, Woods Technology and Vocational Occupational Exploration.²² For all of these courses except photography, the cost of consumable supplies was partially funded by the Industrial Arts Education Service.²³

²²Data obtained from State Department of Education records of teaching assignments for individual instructors in Lynchburg City Schools.

²³Funding provided to local school divisions by the Industrial Arts Education Service is based on Full Time Equivalent (FTE) student enrollment. A full day is considered to be five teaching periods. Thus, one FTE is equal to one student taking five one-period industrial arts courses, or five students each taking one one-period industrial arts course. FTE funding has varied from \$150-\$200 since it was first provided in 1973. However, Marshall Tetterton points out that the Standards of Quality (SOQ) also provide funding to local districts for students participating in industrial arts and other courses. Since the FTE funding supplements SOQ reimbursements, it is not possible to get a true picture of State funding for industrial arts programs by looking only at the money provided through the Industrial Arts Education Service. This is true for funding provided to all Virginia school divisions.

Danville

Like Lynchburg, Danville's industrial arts program was changed very little by the initial curriculum revision efforts of the mid-1960's. Indeed, at the end of the 1967-68 school year, the program consisted solely of courses in general metalworking, general wood-working, electricity and drafting.²⁴

In the fall of 1972, Communications Technology was added to the course of study at Danville's only high school, George Washington. Then, in 1973, two changes that were to have far-reaching effects on Danville's industrial arts program took place. One of these changes was the racial integration of the school system. Prior to 1973, the schools were arranged on the traditional 6-3-3 basis. Elementary school was considered to encompass the first six years of a child's education, with grades 7-9 being taught in a junior high school. The high school program covered grades 10-12. Under this system, general industrial arts was first made available to students in the seventh grade. When the division integrated, it became necessary to redistribute the students throughout the various existing buildings. To accomplish this, Danville changed from the 6-3-3 format to a 4-3-2-3 system. Under this new arrangement, the elementary school encompassed only grades 1-4. Grades 5, 6 and 7 were taught at the middle school, grades 8 and 9 at Langston Junior High and grades 10, 11 and 12 at

²⁴Telephone interview with George C. Hunt, industrial arts teacher, Danville City Schools, March 27, 1984.

George Washington High School. As a side effect of these changes, the seventh grade general industrial arts program was eliminated.²⁵

Also in 1973, Jack Lewis was appointed as Danville's Supervisor of Industrial Arts. Under his guidance, a completely new industrial arts program was put into place at Langston Junior High at the beginning of the 1974-75 school year. The exploratory unit courses in woods, metals, drafting and electricity that had previously been offered were replaced by the World of Construction (36 weeks), Exploring Technology (36 weeks) and Modern Industries (18 weeks). During that same year, a photography course was added at George Washington.

The 1975-76 school year brought with it additional industrial arts offerings at both the junior and senior high schools. An 18 week Exploring Technology course was made available for ninth grade students and a mandatory 9 week exploratory course was established for all eighth grade students. At the high school, World of Manufacturing and World of Communications classes were offered for the first time.

No further changes were made in the industrial arts curriculum until the 1980-81 school year. At that time, an 18 week World of Construction course was added into the junior high school program, replacing the 36 week course. Also, Modern Industries (18 weeks) was offered at the high school.²⁶

²⁵Telephone interview with Jack Lewis, Supervisor of Industrial Arts, Danville City Schools, March 20, 1984.

²⁶Data obtained from State Department of Education computer printouts of teaching assignments for individual instructors in the Danville City Schools.

By the end of the 1982-83 school year, Danville's industrial arts curriculum allowed students to advance from the mandatory eighth grade 9 week exploratory program to courses in either the World of Construction or Exploring Technology. Tenth graders were allowed to take either the World of Manufacturing or Communications Technology. Participation in the ninth grade courses was not a prerequisite for the sophomore classes. Eleventh and twelfth graders could study either woodworking, electricity, metalworking, photography, mechanical drawing or graphic arts. First and second year sections of each class were offered, with the first year classes having no prerequisites.

Richmond

In the Richmond City Schools, the evolution of industrial arts was very gradual.²⁷ In the late 1960's, industrial arts programs in the city followed the traditional model in which several instructors taught unit classes in a single, multi-purpose general laboratory.²⁸ The net effect of this change was to make all industrial arts offerings more theory-oriented, and to emphasize career education rather

²⁷This may be due, in part, to the fact that Bill Eister, the current industrial arts supervisor, is only the third person to hold that position in 62 years.

²⁸Personal interview with Bill Eister, Industrial Arts Supervisor, Richmond City Schools, June 14, 1983.

than individual projects.²⁹ As a result, industrial arts programs came to be seen as serving three distinct purposes: providing vocational students with information to help them make course selections at the vocational center, reinforcing the skills learned by college-bound students in academic classes, and providing all students with the benefits of membership in the Virginia Chapter of the American Industrial Arts Student Association.³⁰

One effect of this restructuring was a change in the types of courses offered throughout the city. At the middle school level, students were eligible to take the courses Exploring Technology (18 weeks), Modern Industry (18 or 36 weeks) and/or World of Manufacturing (18 or 36 weeks). This was a distinct change from 1975-76, the last year in which the only offerings at this level were sixth, seventh and eighth grade General Industrial Arts.³¹

The change in curriculum content also led to a change in teaching methods. Instead of the exclusively project-oriented approach used in the General Industrial Arts courses, students became involved in the study of industry through group projects, industrial simulation and written research assignments.

²⁹Telephone interview with Russell Seldon, industrial arts teacher, Richmond City Schools, April 19, 1984.

³⁰Personal interview with Bill Eister, June 14, 1983.

³¹Data obtained from State Department of Education records of teaching assignments for individual instructors in the Richmond City Schools, and from Richmond's January 1982 VEMS 1f schedule.

At the high school level, the traditional General Industrial Arts and unit courses taught until the late 1960's also disappeared. During the 1971-72 school year, the first World of Manufacturing and World of Construction courses in Richmond's schools were offered at George Wythe High School. The next year, the same two courses opened at John Marshall, Maggie Walker and John Kennedy High Schools.

Armstrong, Huguenot and Thomas Jefferson High Schools never offered either the World of Manufacturing or the World of Construction. Instead, their program of studies included such courses as Wood Technology; Basic Technical, Engineering and Architectural Drawing; Metals Technology; Graphic Communications; and Power and Transportation Technology.³² This divergence between offerings in industrial arts courses, as well as courses in other curricula, led the Richmond City School Board to adopt a policy that is unique among the systems included in this study: rather than trying to duplicate institutional facilities at each school, students were allowed to move from building to building in order to receive instruction in the elective courses they choose to take.

Industrial arts at the high school level also became career-oriented. Woods Technology classes, for example, often centered around woodworking in the construction industry. Thus, rather than building pieces of furniture, students were more likely to work in groups

³²Data obtained from State Department of Education records of teaching assignments for individual institutions in the Richmond City Schools.

building salable items such as storage sheds. These projects were then sold to fund student participation in AIASA activities. Unlike the cost of consumable supplies, AIASA-related expenses received no State reimbursement. (Every industrial arts student in Richmond became an AIASA member by enrolling in their industrial arts class.)

At all levels, instructors had the freedom to incorporate varying amounts of individual project work into the curriculum. The amount of time spent in this manner varied according to the needs and desires of the students in the class. By June 1983, Richmond's industrial arts program had been arranged to meet the specific needs of the individual students enrolled in the various courses.³³

By the end of the 1982-83 school year, industrial arts programs in the three divisions involved in this study had changed dramatically from their original form. As a result of these changes, industrial arts programs were more able to meet the goals set by Calvin Woodward for Washington University's Manual Training School in 1879: to teach a student "to deal successfully with the men, things, and activities which surround him".³⁴

³³Telephone interview with Russell Seldon, April 19, 1984.

³⁴Woodward, p. 229.

EPILOGUE

This study was undertaken to help document the evolution of industrial arts in selected areas of Virginia. The school systems examined were selected from the Virginia Industrial Arts Association's list of the first seven public school divisions in the State to offer manual training courses. A decision to limit the study to three systems was made to obtain a large enough pool of data to make the research useful, yet restrict the amount of material to a manageable size. The Richmond, Lynchburg and Danville city school divisions were chosen because they are located in diverse geographical areas, yet all are convenient to Blacksburg. Should future researchers seek to expand this study, it is suggested that they not concentrate on how industrial arts developed in systems that were among the first to offer non-vocational industrial training. Instead, it is recommended that they obtain contrasting data by researching the development of industrial arts programs in rural areas of the State.

It can be seen that industrial arts programs in Richmond, Lynchburg and Danville have undergone many changes over the years. Further, all three systems underwent similar changes at roughly the same time. The first third of the 20th century was a time of establishment and expansion for manual training/industrial arts courses in all three school divisions. This growth was the result of locally felt need for such courses, and a 1929 State Department of Education

decision to support their implementation. After this came a period of relative stagnation which lasted almost 40 years. In the late 1960's and early 1970's, a new concept of industrial arts began to emerge. Under the direction of the State Department of Education's Industrial Arts Education Service, the program of studies in each system was restructured into its current format. As a result of these and similar changes in other school divisions throughout the State, Virginia has come to be recognized as a national leader in industrial arts curriculum development.

Despite this, the goals of industrial arts have largely remained constant. In Virginia, at the elementary school level (grades K-5), industrial arts is designed to provide learning reinforcement to students and to develop a basic awareness of the technological society in which we live. At the junior high school or middle school (grades 6-9), the curriculum seeks to help students identify their areas of interest and make responsible occupational and educational choices. At the high school (grades 9-12), industrial arts helps students adapt to our technical culture by providing them with personal enrichment and pre-vocational training.¹ According to the Director of the Industrial Arts Education Service, all of the changes that have occurred in recent years have been designed to help achieve these goals.²

¹The Industrial Arts Curriculum, K-12, 1980.

²Personal interview with Tom Hughes, July 27, 1983.

When read in the context of recent national developments, this study may also give some hints as to the challenges that face industrial arts in the coming years. The character of American industry is undergoing profound changes. Since the end of World War II, our national economy has become less dependant upon the traditional "heavy" manufacturing industries. At the same time, service-oriented industries have become increasingly important. This has caused fundamental changes in certain aspects of American society. Education must keep pace with these changes.

Industrial arts has the capability to play an important role in future educational strategies. It may well be the only area of the overall school program that can provide students with practical applications of advances in science, mathematics and the humanities. At the same time, industrial arts must continue to fulfill its traditional responsibility of offering personal enrichment experiences if it is to help students develop avocational interests. To balance these responsibilities in a way that reflects the changes in American industry may well be the greatest challenge to leaders in the profession as we move into the 21st century.

Technology education, a relatively new development in industrial arts curriculum planning, has been proposed as an answer to this challenge. Technology education has been described as an effort to

"educate people to think and act from a technological perspective".³

If it turns out that technology education is not the answer to the problem facing the profession, other solutions must be developed and tried. If the challenge of the future is not met, industrial arts could become obsolete.

³"Pioneering Leadership in Industrial Arts/Technology Education - a Professional Improvement Plan", Journal of Epsilon Pi Tau, 9 (Spring 1983): 2.

REFERENCES

- Buffer, Jr., James J. "Industrial Arts Curriculum - Past, Present, and Future." Curriculum Projects. Washington, D.C.: American Industrial Arts Association, 1973.
- Deyerle, Frances Adams. "Public Education and Public Schools of Lynchburg, Virginia." Reed Library, Lynchburg, Va.
- Eister, William. Organization and Curriculum of the Industrial Arts Education. Richmond: Richmond City Schools, n.d.
- Feirer, John L. and John R. Lindbeck. Industrial Arts Education. Washington, D.C.: Center for Applied Research in Education, 1964.
- Frank, John, Thomas A. Hughes and Chester Lane. The Virginia Industrial Arts Association, 1958-1978. Richmond: Virginia Industrial Arts Association, 1978.
- Householder, Daniel. Review and Evaluation of Curriculum Development in Industrial Arts Education. Bloomington, Ill.: McKnight Publishing Co., 1972.
- Hughes, Thomas A., George Swanik, Marshall O. Tetterton and Arvid W. Van Dyke. Industrial Arts Program of Studies. Richmond: Industrial Arts Education Service, 1978.
- Hughes, Thomas A., and Marshall O. Tetterton. Industrial Arts Curriculum Guide. Richmond: Industrial Arts Education Service, 1978.
- Hughes, Thomas A. and Marshall O. Tetterton. Industrial Arts for the Seventies. Richmond: Industrial Arts Education Service, 1970.
- Industrial Arts in Education. Washington, D.C.: American Vocational Association, n.d.
- Maley, Donald. The Maryland Plan. New York: Benziger, Bruce and Glencoe, Inc., 1973.
- Olstead, Harry B. "American Industry: A New Direction." Curriculum Projects. Washington, D.C.: American Industrial Arts Association, 1973.
- Olson, Delmar W. Industrial Arts and Technology. Englewood Cliffs, N.J.: Prentice-Hall, 1963.

"Pioneering Leadership in Industrial Arts/Technology Education - A Professional Improvement Plan." Journal of Epsilon Pi Tau, 9 (Spring 1983): 2.

Schwartz, Arthur. Virginia Industrial Arts Association, the History. Richmond: Virginia Industrial Arts Association, 1969.

Silvius, G. Harold and Estell H. Curry. Managing Multiple Activities in Industrial Education. Bloomington, Ill.: McKnight and McKnight Publishing Co., 1971.

Superintendent's Annual Report to the Richmond City School Board, 1891-1927. School Board Office, Richmond, Va.

Willcox, George R. Organizing the Industrial Arts Student Association. Richmond: Industrial Arts Education Service, 1978.

Woodward, Calvin M. The Manual Training School. Boston: D. C. Heath and Co., 1887.

APPENDIX A

Industrial arts in Richmond, Virginia, 1926-27.

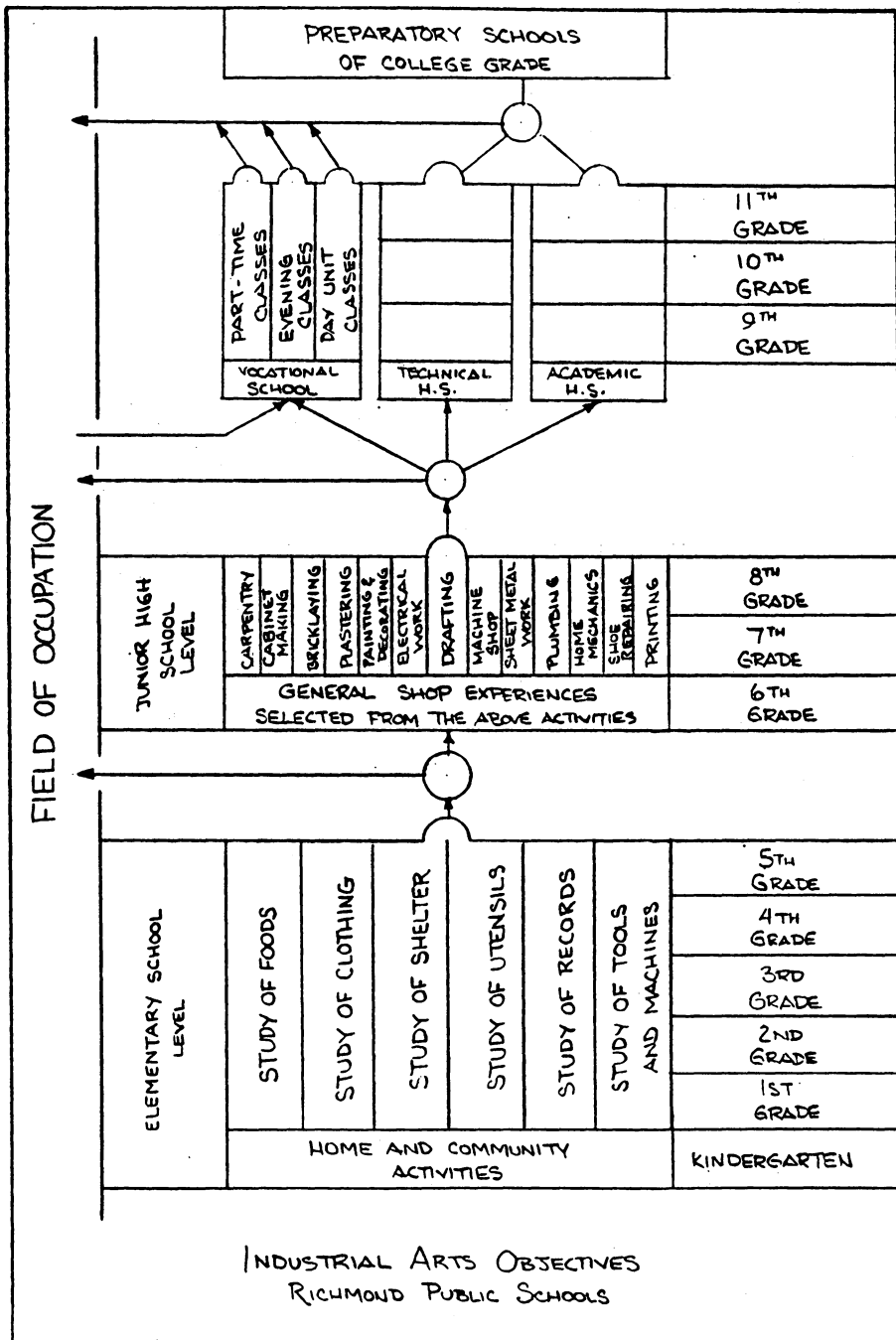

APPENDIX B

These courses are listed in the publication The Industrial Arts Curriculum, K-12 as being approved for study in Virginia's public schools. This approval presumes that the courses will be taught at the grade levels listed and for the indicated length of time.

<u>Course Name</u>	<u>Grade Level(s)</u>	<u>Length (weeks)</u>
Architectural Drawing	10-12	36
Basic Technical Drawing	9-12	36
Communications Technology	9-12	36
Electricity and Electronics Technology	10-12	36
Energy and Power	10-12	36
Engineering Drawing	10-12	36
Exploring Technology	6-9	18, 36
Graphic Communications	10-12	36
Materials and Processes Technology	9-12	36
Metals Technology	10-12	36
Modern Industry	6-9	18, 36
Power and Transportation Technology	9-12	36
Woods Technology	10-12	36
Construction	6-9	18, 36
Manufacturing	6-9	18, 36

**The vita has been removed from
the scanned document**