

**A Two-Point
Vehicle Classification System**

by
Bernard Curtis McCullough Jr.

Thesis submitted to the Faculty of the
Virginia Polytechnic Institute and State University
in partial fulfillment of the requirements for the degree of
Master of Science
in
Civil Engineering

APPROVED:

Siamak A. Ardekani, Chairman

Donald R. Drew

Antoine G. Hobeika

February 22, 1988
Blacksburg, Virginia

**A Two-Point
Vehicle Classification System**

by

Bernard Curtis McCullough Jr.

Siamak A. Ardekani, Chairman

Civil Engineering

(ABSTRACT)

The counting and classification of vehicles is an important part of transportation engineering. In the past twenty years many automated systems have been developed to accomplish that labor-intensive task. Unfortunately most of those systems are characterized by inaccurate detection systems and/or classification methods which result in many classification errors, thus limiting the accuracy of the system.

This report describes the development of a new vehicle classification program, originally designed for use in the Two-Point-Time-Ratio method of vehicle classification, which could greatly improve the accuracy of automated classification systems. The program utilizes data provided by either vehicle detection sensors, or the program user, to determine the velocity, number of axles, and axle spacings of a passing vehicle. It then matches the axle numbers and spacings with one of forty-one possible vehicle classifications and prints the vehicle class, speed, and wheelbase lengths. It also tabulates and prints totals and average speeds for each vehicle type.

This report then describes a roadside experiment conducted to test the accuracy of the program, and the results of that experiment, which show the program classifications to be highly accurate.

The report then describes the options available within the program, and provides instructions and an example on the use of the program. Possible future expansions of the system are also cited.

Acknowledgements

I would like to extend my sincere appreciation to my major advisor, S. A. Ardekani, for his time, patience, valuable suggestions, and continuous help.

I also wish to thank the other members of my graduate committee: D. R. Drew, for his guidance and the valuable skills derived from his courses, and A. G. Hobeika for his continuous help in my endeavors.

I am also deeply grateful to my parents for their patience, their support, and for many other things too numerous to list. I must thank _____ and _____ for their technical contributions. Lastly, I wish to thank my friends, _____ and _____, for their help and support.

Table of Contents

1.0 Introduction	1
2.0 Literature Review and Problem Statement	3
2.1 The ALICE Method	3
2.2 The Two-Point-Time-Ratio Method	6
2.3 The Problem	9
2.4 Objective	10
3.0 Theory	11
3.1 Speed And Wheelbase Determination	11
3.2 Vehicle Classification	12
3.2.1 Methodology	12
3.2.2 Vehicle Classes	14
3.2.2.1 Motorcycles	16
3.2.2.2 Passenger Cars	17
3.2.2.3 Single-Unit Trucks	19
3.2.2.4 Buses	20

3.2.2.5	Tractor-Trailers	21
4.0	Analysis and Results	25
4.1	Accuracy Analysis Experiment	25
4.1.1	Experiment Methodology	25
4.1.2	Data Analysis	26
4.2	Experimental Results	27
5.0	Software Description	29
5.1	Software Overview	29
5.1.1	Automatic Mode	30
5.1.2	Interactive Mode	30
5.2	Interfacing	31
5.3	Applications	32
5.4	Possible Extensions	33
6.0	Summary and Conclusions	34
Bibliography		36
Appendix A. The CLASSIFY Classification Program		37
Vita		55

List of Illustrations

Figure 1. Principle of the ALICE method	5
Figure 2. ALICE classification groups and ranges	7
Figure 3. Principle of TPTR method	8

List of Tables

Table 1. Vehicle Classes and Descriptions	15
Table 2. Wheelbase Ranges (In Feet) by Class	24
Table 3. Results of Classification Accuracy Experiment	28

1.0 Introduction

For centuries man has sought new and better ways to efficiently transport goods and people. Early efforts involved the development of better boats and ships, and the building of man-made canals and locks to link navigable waterways. A vast system of urban streets and rural roads was created to facilitate transport by wagon, cart, and carriage. In the nineteenth century, the invention of the steam locomotive led to the creation of railroads, which provided a much faster means of transportation. But all of those modes of transport, and the airplane invented thereafter, were not as significant as that which dawned with the invention of the automobile. The automobile allows a personal freedom not available with any other mode, and that is probably the reason for its extreme popularity.

In 1912, the United States Government realized that a vast network of public roads had to be built and maintained for automobile travel. Today, that network is comprised of a staggering 3.8 million miles of highways. Unfortunately that growth has not been able to keep up with the steadily rising number of automobiles in the U.S. Thus many urban areas (and even some rural areas) are plagued with congestion problems.

To prevent such problems from occurring, and to alleviate those which do occur, careful planning and monitoring is needed. This is often accomplished through the use of traffic surveillance and control systems or traffic flow data collection systems. Those systems are

also used in pavement management and maintenance to estimate pavement loads due to various types of trucks, which is dependent upon the axle configuration. Such systems are used in a similar way in bridge maintenance and management. A common feature of such systems is a method of counting and classifying the number of vehicles using the facility. For many years this was commonly done by roadside observers who spent long hours sitting in a vehicle along the facility, manually recording and totaling the number and type of the vehicles going by. The job was tedious and the pay was usually minimum wage, but because of the manpower and manhours required, the cost of such a count was often high. To offset such costs, many techniques for the automatic counting, length determination, and classification of vehicles have been developed within the past decade. One popular method, especially in Europe, is the Automatic Length Indication and Classification Equipment method, known as 'ALICE', which was introduced by D.D. Nash in 1976.¹ This report covers a simpler, more accurate, system of vehicle counting and classification, and details the development of the classification software which will enable it to surpass previous systems in accuracy.

¹ D.D. Nash, "ALICE: Automatic Length Indication and Classification Equipment, An equipment for automatically classifying vehicles and measuring their speed", *Traffic Engineering & Control* Vol. 17 No. 12 (December 1976), pp. 195-201.

2.0 Literature Review and Problem Statement

Although many articles on vehicle classification methods have appeared in transportation journals within the past decade, most have dealt solely with new types, or applications, of vehicle detection systems. For the actual classification of the vehicles detected, most have depended upon the classification method developed by D.D. Nash for his Automatic Length Indication and Classification Equipment system. Therefore we shall begin with with an overview of that system, which shall be referred to as the ALICE system.

2.1 *The ALICE Method*

In 1974, during a project known as the West London Area Traffic Control Experiment in England, planners encountered a major problem. Due to the traffic composition changes that occurred at various times, it was determined that the vehicular counts to be utilized in the experiment would have to be weighted by vehicle type. An investigation of the traffic instrumentation equipment that was available at the time revealed that nothing met the needed requirements, and thus the planners set out to create such a system. What they created was

termed the Automatic Length Indication and Classification Equipment, or ALICE, method. It was introduced in an article by D.D. Nash in the December 1976 issue of *Traffic Engineering & Control*.

ALICE utilizes two loop detectors and an axle detector (Figure 1), which are placed in sequence in a short (about 5.5 meter) segment of highway.

As a vehicle enters the segment, it is detected by the first loop detector, and then by the second loop detector after a short time interval, called t_1 . The axles of the vehicle then trip the axle detector as they pass, and the time interval between axles, called t_2 , is recorded. The time intervals are measured using a rather complex circuit comprised of a crystal oscillator, a comparator, and several counters. The distance between the leading edges of the two loop detectors, called d_1 , is known, and is related to t_1 and the velocity of the vehicle. Likewise, t_2 is related to the velocity of the vehicle and the distance between the two axles, termed d_2 . Since this produces two equations with two unknowns, d_2 can be determined. This calculation is performed within the circuit, which results in the recording of the length, axle spacings, speeds, and gap distance for each vehicle that passes through the segment.

The ALICE system then compares the axle number and spacing data of the vehicle with a data base, consisting of the axle number and spacing ranges of fourteen vehicle groups, using a logic program. The data base includes the following classification groups as termed by ALICE (and as commonly referred to):

1. Motorcycles.
2. Private cars and light vans.
3. 2-axle heavy goods vehicles (2-axle single unit trucks or vans).
4. 3-axle rigid goods vehicles (3-axle single unit trucks).
5. 4-axle rigid goods vehicles (4-axle single unit trucks).
6. 3-axle articulated lorries (3-axle tractor-trailers).
7. 4-axle articulated lorries (2-axle tractors with 2-axle trailers).
8. 5-axle articulated lorries (2-axle tractors with 3-axle trailers).

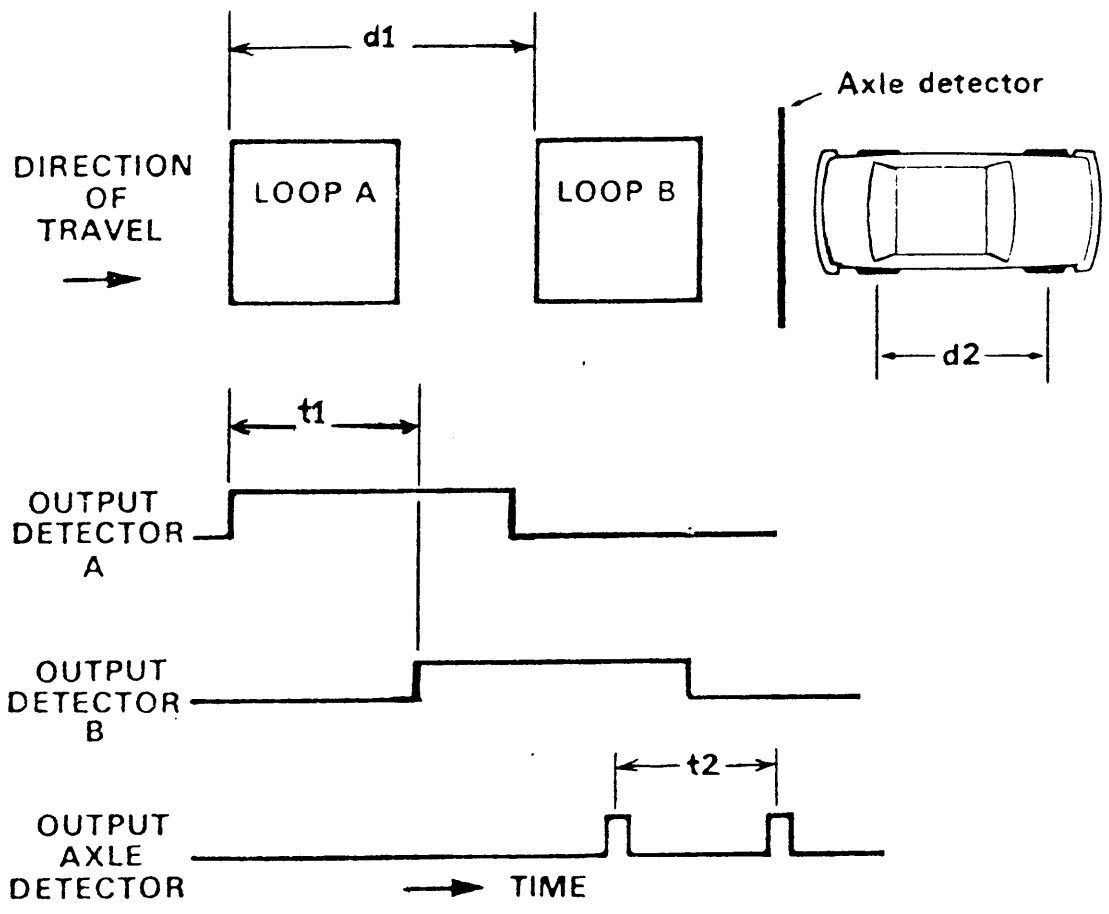

Figure 1. Principle of the ALICE method

9. 4-axle articulated lorries (3-axle tractors with 1-axle trailers).
10. 5-axle articulated lorries (3-axle tractors with 2-axle trailers).
11. 6-axle articulated lorries (3-axle tractors with 3-axle trailers).
12. Road trains (single unit trucks with trailers).
13. Cars with caravan/trailer.
14. Buses or coaches.

If the axle data of the vehicle fits within the spacing ranges of one of those groupings (Figure 2), then the vehicle is classified as a member of that group and recorded.

2.2 The Two-Point-Time-Ratio Method

The Two-Point-Time-Ratio, hereafter referred to as TPTR, method of vehicle classification is similar to that of the ALICE method, except that only two vehicle detectors are needed to determine the same data, and thus is more efficient in its use of hardware. The detector sensors are placed in a short section of highway, similar to that of the ALICE sensors, but offer more flexibility because, unlike ALICE, any combination of passage loop detectors, presence loop detectors, or axle detectors may be utilized. For simplicity we shall refer to the first detector in the sequence as sensor A, and the second detector as sensor B as shown in Figure 3.

As a vehicle enters the segment, its front axle is initially detected by sensor A, and then by sensor B after a short time interval, which will be referred to as T_0 (and is equivalent to the variable t_1 in the ALICE method). The time interval(s) between axle detections at sensor A are also determined, with T_1 representing the time interval between the first and second axles, T_2 representing the time interval between the second and third axles, etc... This system, which was developed and tested in China, is presently undergoing further developments at

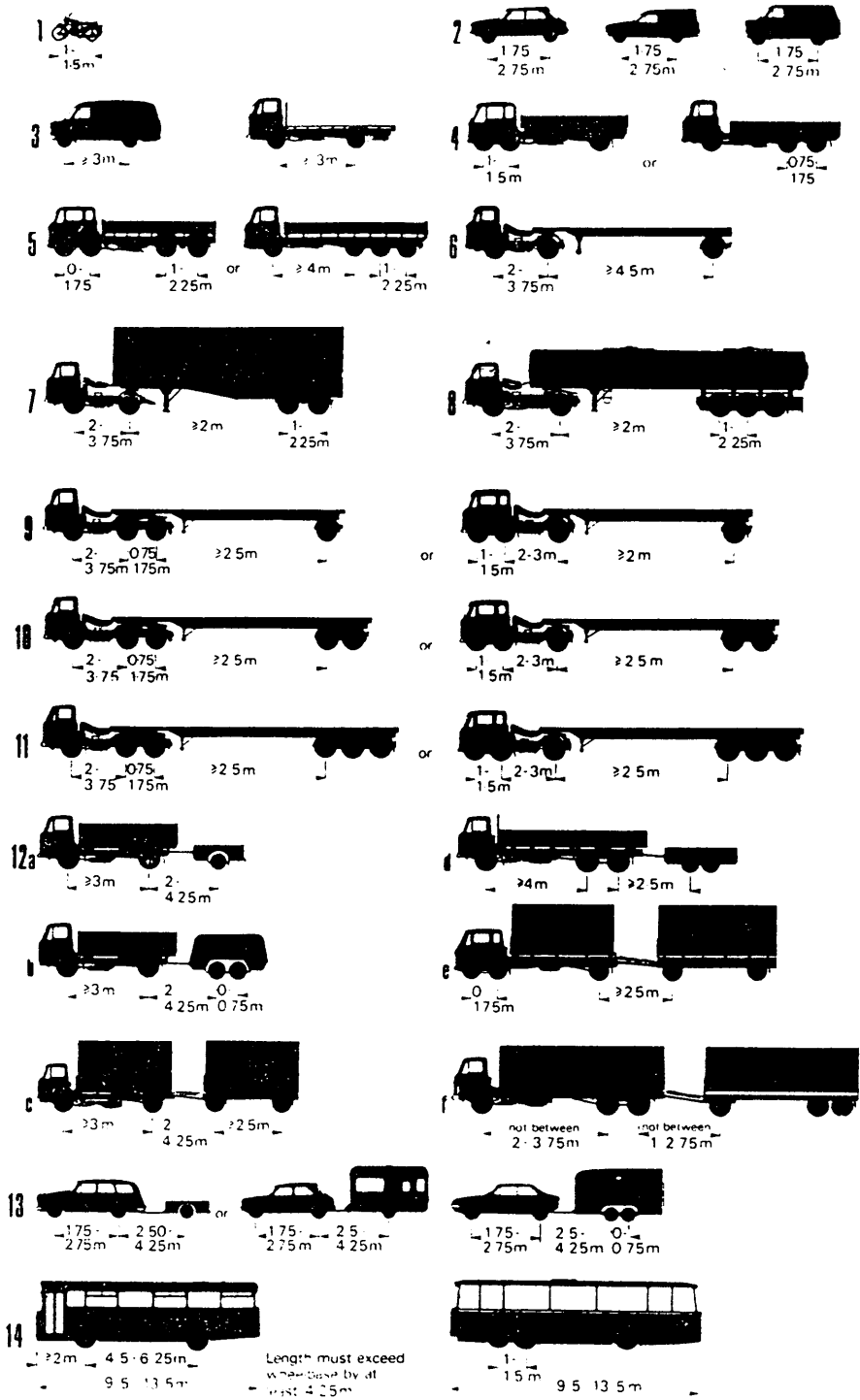

Figure 2. ALICE classification groups and ranges

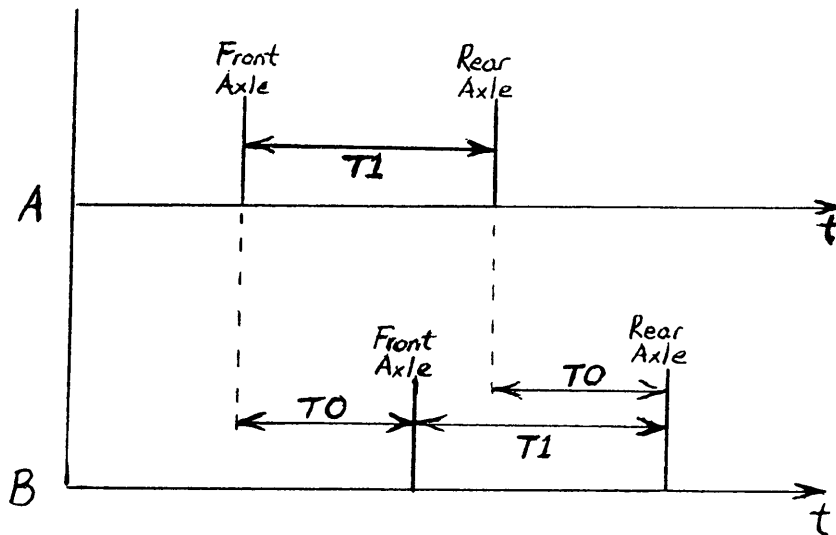
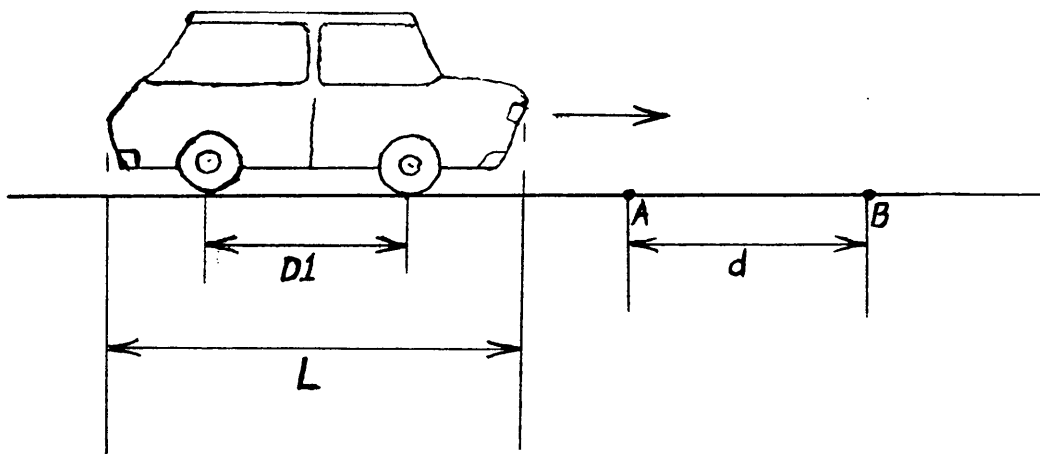

Figure 3. Principle of TPTR method

Virginia Polytechnic Institute and State University under the supervision of its developer, Li-Ren Huang.

2.3 *The Problem*

As the work progressed on the circuitry necessary to interface the TPTR sensors with a microcomputer, the focus shifted to possible classification programs. The first such program that was considered was a program that would utilize the methodology of the ALICE system, but it was determined that such a program would not be well suited for use with the TPTR system for several reasons. One of the predominant reasons was the limited number of vehicle classes covered by the ALICE data base. Since the data base resulted from observations in England in the early 1970's, it was biased to vehicles of European design, which in some cases are very different from North American designs. For example, a two-axle vehicle with a wheelbase of 10 feet (3.07 m), such as the typical American-made, sedan-type passenger car, would be classified as a 2-axle heavy goods vehicle by a classification system using the ALICE grouping ranges. The ALICE data base also contains many axle configurations, such as three-axle full trailers, which are very rarely seen in North America. The data base also lacks groupings for vehicles, such as tractor twin-trailers, which have become common in recent years. Therefore it was determined that an updated, and more extensive, classification program was needed for the TPTR system.

2.4 Objective

The objective therefore was to create a flexible, modern, classification program that could be interfaced to operate automatically with the TPTR system, or operated interactively by an individual, and would result in greater accuracy than the ALICE system, especially when used in North America.

3.0 Theory

This classification program was set up such that it could be used in either of two modes. The first mode, referred to as automatic mode, is for use when the microcomputer is directly interfaced with the sensors. In that mode data is retrieved directly from the storage file. The second mode, referred to as interactive mode, is interactive and allows data to be entered from the computer keyboard in either time interval or wheelbase spacing form. The classification theory utilized by both modes is the same, and the process can be divided into two steps: speed and wheelbase determination, and vehicle classification.

3.1 Speed And Wheelbase Determination

The theory behind the calculation of speed in this program is simple. Point A and point B, the locations of the two sensors, are a known distance apart. That distance is entered into the microcomputer via the keyboard in one of the early steps of using the program. The time taken by the vehicle to travel that distance, T_0 , is also known (one of the time intervals re-

trieved from data storage or entered by the operator). Therefore, by dividing the distance by the time, the program computes the speed of the vehicle.

The program then uses that speed calculation and the time intervals between axles (T1,T2...) to compute the axle spacings. The simple theory behind this computation is the relationship that states that time multiplied by speed is equal to distance. Therefore the program can compute D1 (the distance between the first two axles) by multiplying T1 by the vehicle speed. Likewise, D2 can be calculated from T2, D3 from T3, etc...

Those simple calculations result in the speed of the vehicle and, more importantly, the axle spacings, which are the basis for the vehicle classification.

3.2 Vehicle Classification

3.2.1 Methodology

The classification theory on which this program is based rises from the fact that the number, and spacing, of a vehicle's axles are closely related to the length and use of that vehicle. Due to different designs, manufacturers, and options, very few of the thousands of vehicle models produced are exactly alike in all wheelbase measurements. But while no single set of measurements can be used, ranges can be developed which will include most, if not all, of the vehicle models that are similar in appearance and function. For example, one vehicle type is that of the passenger automobile, which is intended for the transport of a small number of people and low amount of weight. It is characterized by a frame which has two axles, a length of less than twenty feet, and a wheelbase spacing of between six and thirteen feet. The development of such ranges for all of the vehicle types is discussed later in the

section titled "Vehicle Classes". Those ranges are the basis for the logic program that is used for classification.

In the first step of the classification process, the program retrieves the axle count and proceeds to the section where vehicles with that number of axles are analyzed. The program then retrieves the axle spacing data and compares it to the axle spacings ranges of the most common vehicle class with the same number of axles. If all the axle spacings of the vehicle fit within the ranges of that class, then the vehicle is classified as a member of that class. If not, then the axle data is compared to the ranges of the second most common vehicle, etc., until the vehicle is classified. If the vehicle data does not fit into all the ranges of any of the vehicle classes within that section, then the vehicle is classified as an "Unknown X-Axle Vehicle" (where X is the number of axles). This is unlike the ALICE method which classifies any vehicle that does not fit within any other group into group 12 ("Road Trains"). Due to the design of this program, it is impossible for a vehicle to be classified into more than one group, but in those cases where a vehicle's wheelbase can be associated with more than one class, the operator is alerted through an information screen which may be viewed after the classification. That screen lists the most common vehicle in the class, other vehicles within the class, and vehicles of other classes which may be erroneously classified into that class due to similar axle spacings.

As an example, a two-axle vehicle with a 14' wheelbase is detected by the sensors. The program shifts to the section for analysis of two-axle vehicles, and after unsuccessfully comparing the 14' wheelbase with the range for small and midsize car class (6'-9'), and the range for large passenger car class (9'-13'), it successfully matches that wheelbase to the two-axle single-unit truck class (13'-25'). Therefore the vehicle is classified as a two-axle single-unit truck. That classification is displayed on the screen along with the calculated speed of the vehicle (in miles per hour) and the wheelbase. A quick glance at the information screen, evoked with a response of 'yes' to the next prompt, reveals that the most common vehicle in this class is indeed the two-axle single-unit truck, and that recreational vehicles (RV's), and conventional schoolbuses, are also included in the class. It also reveals that limousines and

crew-cab pickup trucks (both members of the large passenger car class) have wheelbases which may cause them to be incorrectly placed in this class.

The program also tabulates totals as the program proceeds. Those totals include the number of motorcycles, cars, single-unit trucks, buses, tractor-trailers, and others. The average speed of each of those groups is also tabulated (through the use of an incremental counter that totals calculated speeds for a group and divides the total by the group vehicle count) and displayed along with a breakdown of the number of each class within the group.

The method used by this program is important, but the key to its success is the extensive number of vehicle classes covered, and the ranges developed for each.

3.2.2 Vehicle Classes

In the early stages of the project, visual research was conducted to determine a list of the predominant vehicle types or 'classes'. That research, which consisted of watching the surrounding traffic for new types of vehicles while driving, was conducted on several roads and highways in the state of Virginia. The number of axles, along with their configuration and approximate spacings, was noted for many vehicle types, with special attention being given to those types which were not covered within ALICE's classes. Vehicle types common in other areas of North America, but prohibited in Virginia, such as triple-trailer truck units, were also included in the list. This continued until it was believed that all of the major, and as many as possible of the minor, types of vehicles had been accounted for in the list. Each of the vehicle types was then given a two-digit class number for identification. The list of vehicle types and their identification classes are shown in Table 1.

The numbering system was developed by Dr. Izadmehr for his dissertation at the University of Texas in 1986. The first digit refers to the number of axles of the vehicle type, and

Table 1. Vehicle Classes and Descriptions

Class	Vehicle Description
21	Small or midsize passenger car, jeep, small pickups
22	Large passenger car, fullsize pickup truck, vans
23	Two-axle single-unit truck, RV's, schoolbuses
24	Motorcycles or mopeds
25	Two-axle transit bus
31	Three-axle single-unit truck
32	Two-axle tractor with one-axle semitrailer
33	Passenger car with single-axle trailer
34	Motorcycle with trailer
35	Three-axle transit bus or coach
36	Two-axle single-unit truck with one-axle trailer
41	Two-axle tractor with two-axle semitrailer
42	Three-axle tractor with one-axle semitrailer
43	Four-axle single-unit truck
44	Passenger car with two-axle trailer
45	Two-axle single-unit truck with two-axle trailer
46	Three-axle single-unit truck with one-axle trailer
51	Three-axle tractor with two-axle semitrailer
52	Two-axle tractor with two short trailers
53	Three-axle single-unit truck with two-axle trailer
54	Four-axle single-unit truck with one-axle trailer
55	Two-axle tractor with three-axle semitrailer
61	Three-axle tractor with three-axle semitrailer
62	Three-axle tractor with two short trailers
63	Four-axle single-unit truck with two-axle trailer
64	Four-axle tractor with two-axle semitrailer
71	Three-axle tractor with long and short trailers
72	Two-axle tractor with three short trailers
73	Four-axle tractor with three-axle semitrailer
81	Three-axle tractor with three short trailers
91	Three-axle tractor with two long trailers

the second digit refers to the axle spacing pattern.² Extensive research was then performed to find suitable wheelbase ranges for each of the vehicle types in the list.

The development of the ranges for each class often depended upon the development of ranges for other classes within the same vehicle group. Therefore, the development of the ranges, will be discussed on a group by group basis, with a table provided at the end of the section which shows the ranges for each class. In those tables, W1 represents the distance between the first and second axles, W2 represents the distance between the second and third axles, etc...

3.2.2.1 Motorcycles

The vehicle type that is most easily identified from its wheelbase is the motorcycle (class 24). Although model lengths have tended to increase in recent years, the wheelbase has remained much shorter than that of any other vehicle. The first range considered for this vehicle type was the 1-1.5 meter range used by ALICE. Visual research showed that the lower limit was appropriate but that some models had wheelbases exceeding the upper limit. Therefore the lower limit was converted to the nearest equivalent length in feet, which was three feet, and the upper limit was extended to six feet, a distance that would include all the models inspected.

Motorcycles with small trailers were also encountered during research and were therefore also included in the vehicle list as class 34. These vehicles consist of a cycle with a short single-axle trailer connected to it at the hub of the rear wheel to provide additional luggage or storage space. The vehicles inspected were found to have distances of approximately three to seven feet between the rear cycle axle and the trailer axle. Since these trailers can

² Izadmehr, B., "Automatic Vehicle Classification System", Ph.D. Dissertation, University of Texas, 1986, pp. 109-117.

be used with most cycles, the range used for the distance between the first and second axles, W1, was the same as that used for class 24 (3-6 feet).

3.2.2.2 *Passenger Cars*

The most common type of highway vehicle is the passenger car, which accounts for more than half of the traffic on a typical highway. Every year, several manufacturers produce millions of these vehicles in a variety of hundreds of models and sizes. These range from tiny two-door sub-compact models to limousines. Naturally, most of those models have different wheelbases, encompassing a wide range. As an example of the wide range in car wheelbases, one can look at the 1988 Yugo and compare it to the 1988 Cadillac Fleetwood. The Yugo has a wheelbase of 84.6 inches, whereas the Fleetwood has a wheelbase of 134.4 inches, a difference of 50 inches in cars produced in the same year.³ Research determined that the shortest wheelbase among car models produced in the past fifteen years was the 83.0-inch span of Triumphs produced between 1972 and 1980.⁴ The vehicle with the longest wheelbase within the same period was the 1975 Cadillac Fleetwood with a span of 151.5 inches.⁵ For most years however, the longest wheelbase was 145 inches or less. If present trends continue, cars in the future will have shorter wheelbases than those present seen. Such a trend led to the consideration of the lower limit of six feet used by IZADMEHR.

Pickup trucks and vans are also included in the passenger car classes and thus research was likewise performed to determine the upper limits of their wheelbase ranges. The lower limit was not examined thoroughly because field observations had revealed that limit to be much longer than 83 inches. From brochures of various manufacturers it was determined that

³ "Engineering Specifications and Statistics: Motor Vehicles", *Chilton's Automotive Industries* Vol. 166 No. 3 (March 1987), pp.57-81.

⁴ "Engineering Specifications and Statistics: Motor Vehicles", *Chilton's Automotive Industries* Vol. 152 No. 7 (April 1, 1975), p.43.

⁵ "Engineering Specifications and Statistics: Motor Vehicles", *Chilton's Automotive Industries* Vol. 150 No. 7 (April 1, 1974), p.48.

most conventional full-sized pickups had wheelbases of less than 145 inches. Crew-cab pickups however had wheelbases of as much as 168 inches.⁶

Based on those figures, and the fact that a significant number of single-unit trucks had been found to have wheelbases as short as 150 inches, the lower and upper limits of the passenger car range were set at six feet (72 inches) and twelve-and-one-quarter feet (147 inches). This class was then split into two classes to create one class, class 21, for small and midsize cars, jeeps, blazers, and small pickups, and another class, class 22, for large cars, vans, and full-size pickups. The point of division was selected as nine feet, the figure used by Izadmehr, because it resembled figures used by automotive magazines for such separation.

Two other classes were created for passenger cars with trailers. Class 33 is for passenger cars, pickups, jeeps, and blazers which are pulling a short single-axle trailer. Class 44 is for such cars pulling a short two-axle trailer. The range for the first axle spacing in each of these classes is the 6 to 12.25 feet range developed above. For the development of the range for the second axle spacing of these classes, other factors had to be considered. The first factor was that three-axle single-unit trucks have a first axle spacing that closely resembles that of larger passenger cars, and have a second axle spacing of two to six feet. The second factor was that the first axle spacing of three-axle tractor-trailers is also similar to that of passenger cars. Those tractor-trailers have a second spacing of eleven to forty-five feet. From visual research it was determined that the distance between the rear passenger car axle and the front trailer axle is usually greater than six feet. It was also determined that for a three-axle vehicle with a second axle spacing of greater than twenty feet, three-axle tractor-trailers were more common than cars with trailers. But for four-axle vehicles with second axle spacings greater than fifteen feet, four-axle tractor-trailers were found to be more common.

⁶ Ford Motor Company, "Ford F-Series Pickup", Brochure #8803, Aug. 1987, p. 19.

Therefore class 33, car with one-axle trailer, was given a range of six feet to twenty feet for the spacing between the second and third axles.

Class 44, car with two-axle trailer, was given a range of six feet to fifteen feet for the second axle spacing, and a range of two to six feet for the third axle spacing, because that is the range of tandem axles.

3.2.2.3 *Single-Unit Trucks*

To determine appropriate intervals for the nine classes of single-unit trucks covered by the program, each class was divided into its component parts. Due to similarities between classes the task could be reduced to the development of intervals for the five components that make up those nine classes. Those components are two-axle, three-axle, and four-axle single-unit trucks, and one-axle and two-axle trailers.

A dissertation by B. Izadmehr at the University of Texas suggests intervals for the classification of single-unit trucks and was used in conjunction with field observations.

The interval of eleven to twenty-five feet is suggested by Izadmehr for two-axle single-unit trucks, but that interval was found to include many passenger cars and pickups, and thus had to be altered. As described earlier in the section on passenger cars, research determined that an appropriate upper limit of the range for the passenger car class would be 12.25 feet, to minimize classification errors between the two classes. Therefore 12.25 feet, inclusive, was decided upon as the lower limit for the interval. After research revealed a significant number of two-axle single-unit trucks with wheelbases of twenty-four feet, the suggested upper limit of twenty-five feet was adhered to.

Izadmehr's paper also suggests an interval of eight to twenty-six feet for the first axle spacing, and an interval of two to six feet for the second axle spacing of three-axle single-unit truck. Since three-axle passenger cars are rare, the same lower limit constraints do not exist for these vehicles. All of the three-axle single-unit trucks observed during research fit within

the suggested range, but some transit buses that were observed had twenty-five foot distances between the first two axles. Thus the ranges within the program for three-axle single-unit trucks were set at eight to twenty-five feet, and two to six feet.

Izadmehr also suggests ranges of eight to twenty-five feet, two to six feet, and two to six feet for the axle spacings of four-axle single-unit trucks. Since all such vehicles observed fit within those ranges, they were adopted into the program.

For the one-axle trailers an interval had to be determined for the distance between the last axle of the preceding truck and the axle of the trailer. As in the previous case with passenger cars, it was determined that ranges which included lengths of less than six feet would result in the classification of the rear axle of some tandem-axle vehicles as a trailer since some tandem-axle sets have spacings of six feet. Likewise, it was determined that ranges with upper limits exceeding fifteen feet would result in numerous misclassifications of short tractor-trailer combinations. The interval selected was six to fifteen feet.

For two-axle trailers, two types were noted. The first type involves a set of tandem-axles near the rear of the trailer. The second type, called a full trailer, has a front axle and a rear axle. The range for single-axle trailers (6'-15') was chosen, along with the typical tandem-axle spacing range of two to six feet, for the first type. Since few examples of the second type of trailer could be found, the first range used by the ALICE system was adopted, and a second range was created which was thought to typify short full trailers. Those ranges are six to twelve feet, and seven to twenty feet, respectively.

The axle space ranges for each class that result from the above component spacings can be seen in Table 2.

3.2.2.4 Buses

Buses are probably the most difficult type of vehicle to differentiate from vehicles of other classes. This is due to the fact that most buses, especially schoolbuses, are constructed on

frames that were designed for single-unit trucks. That results in a range of wheelbases from twelve feet (typical minibus) to over thirty feet (long transit type buses). The most common schoolbus, called a conventional type, has a wheelbase of about twenty-two feet, depending on the manufacturer, and thus cannot be distinguished from a single-unit truck built on the same, or a similar, frame. For that reason schoolbuses were put into the single-unit truck class (class 23). Transit buses and motorcoaches, however, are built on longer frames intended for their purpose.

Transit buses observed during research had wheelbases ranging from twenty feet to well over thirty feet. Intercity motorcoaches observed had first axle spacings ranging from twenty-five to thirty feet.

As you might recall from the previous section on single-unit trucks, a significant number of twenty-four feet wheelbase trucks were observed and thus the upper limit for class 23 was set at twenty-five feet. Since trucks far outnumbered buses in the number of vehicles having twenty to twenty-five feet wheelbases, that limit was not changed. The resulting range for the distance between the front two axles of buses was set at twenty-five to thirty-five feet.

Class 25, two-axle transit buses, was therefore given a wheelbase range of twenty-five to thirty-five feet. Class 35, three-axle transit buses, was given the same first interval, and the typical tandem-axle spacing range, two to six feet, for the second interval.

3.2.2.5 *Tractor-Trailers*

There are fourteen classes of tractor-trailer trucks included within the program. Most of those types are common, while others (such as classes 71, 72, 81, and 91) are only allowed on certain highway sections in some states and may be unfamiliar to most people. Class 71 is a double trailer truck consisting of a three-axle tractor, a tandem-axled semitrailer, and a pup trailer connected using a single-axle dolly. It is legal in at least twenty states, and is commonly referred to as a 'Rocky Mountain double'. Classes 72 and 81 are triple trailer trucks

consisting of a tractor with two axles (class 72) or three axles (class 81), one single-axle semitrailer (or pup trailer), and two pup trailers connected using two single-axle dollies. They are legal on some sections of freeways in a few western states. Class 91 is a double trailer truck consisting of a three-axle tractor and two tandem-axle semitrailers connected using a tandem-axle dolly. It is legal on some sections of highway in at least thirteen states, and is commonly referred to as a 'turnpike double'.⁷ Classes 64 and 73 include four-axle tractors which, although rarely seen a few years ago, have become more popular in recent years for operations involving very heavy loads such as construction equipment.

In order to develop ranges for each of the fourteen types of tractor-trailers in the program, a method similar to that used for single-unit trucks was used. Each class was divided into its components and the result was three types of tractors (one-axle, two-axle, and three-axle), four types of trailers (one-axle, two-axle, three-axle, and short one-axle), and two types of dollies- the devices used to couple rear trailers in multiple trailer trucks (single-axle and tandem-axle). Fortunately, the paper by Izadmehr suggests ranges for all of those components.

First, ranges for the distances between tandem-axle sets within those components were all set to the typical tandem range, two to six feet. That accounted for the ranges between the second and third axles of three-axle and four-axle tractors, the third and fourth axles of four-axle tractors, the axles of tandem dollies, and the axles of two-axle and three-axle trailers.

All of the two-axle tractors observed during research had distances between the first and second axles which fit within the eight to twenty feet range suggested by Izadmehr. Research also failed to reveal a two-axle tractor in production which would not fit into that range, so it was adopted.

For three-axle tractors, Izadmehr suggests a range of eight to twenty-five feet for one of his classes, and eight to twenty feet for the two others. Two three-axle tractors observed during research had axle spacings in the twenty to twenty-five feet range and thus the larger

⁷ Transportation Research Board, National Research Council, *Special Report 211: Twin Trailer Trucks* (Washington D.C., 1986), pp. 212- 219.

range was accepted. Since one four-axle tractor was observed with an axle spacing range of about twenty-two feet, the larger range was also adopted for four-axle tractors.

For the distance between the rear axle of a tractor and the front axle of a trailer, Izadmehr suggests a range of eleven to forty-five feet for both single-axle and two-axle trailers, eleven to forty-two feet for three-axle trailers, and eleven to twenty-five feet for short trailers, of the type seen in twin trailer trucks (hereafter referred to as pups). Due to favorable research results, all of those ranges were accepted, except for the cases (classes 32, 41, 42, 51, 55 and 64) where such a range would have interfered with the ranges of single-unit truck with trailer and passenger car with trailer groups. In those cases the lower limit of the range was set at the upper limit of the conflicting range. Later research showed that some two-axle trailers have splits of up to 12.5 feet between axles, and classes with those trailers were changed accordingly.

Izadmehr's ranges for double trailer trucks (8-20, 11-36, 6-20, and 7-35 feet respectively) were also accepted after research revealed no conflicting data, as was his range of seven to fifteen feet for the distance to the first dolly axle from the preceding trailer axle.

Those ranges were then combined to produce range for all fourteen tractor-trailer types, and can be seen in Table 2.

Table 2. Wheelbase Ranges (In Feet) by Class

Class	W1	W2	W3	W4	W5	W6	W7	W8
21	6-9							
22	9-12.25							
23	12.25-25							
24	3-6							
25	25-35							
31	8-25	2-6						
32	8-20	20-45						
33	6-12.25	6-20						
34	3-6	3-7						
35	25-35	2-6						
36	12.25-25	6-20						
41	8-20	15-45	2-12.5					
42	8-25	2-6	15-45					
43	8-25	2-6	2-6					
44	6-12.25	6-15	2-6					
45	12.25-25	6-15	2-6					
		6-12	7-20					
46	8-25	2-6	6-15					
51	8-25	2-6	15-45	2-12.5				
52	8-25	11-36	6-20	7-35				
53	8-25	2-6	6-15	2-6				
			6-12	7-20				
54	8-25	2-6	2-6	6-15				
55	8-20	11-42	2-6	2-6				
61	8-25	2-6	11-42	2-6	2-6			
62	8-25	2-6	11-36	6-20	7-35			
63	8-25	2-6	2-6	6-15	2-6			
				6-12	7-20			
64	8-25	2-6	2-6	15-45	2-12.5			
71	8-25	2-6	11-45	2-6	7-15	11-25		
72	8-20	11-45	7-15	11-25	7-15	11-25		
73	8-25	2-6	2-6	11-42	2-6	2-6		
81	8-25	2-6	11-45	7-15	11-25	7-15	11-25	
91	8-25	2-6	11-45	2-12.5	7-15	2-6	11-45	2-12.5

4.0 Analysis and Results

4.1 Accuracy Analysis Experiment

To determine the accuracy of the vehicle classification performed by the program, an experiment was developed. The best method of assessing the accuracy would have been to interface vehicle detection sensors with a roadside microcomputer and use the program in the automatic mode. Due to hardware inavailability, time limitations, and interfacing difficulties, however, another method had to be developed. The resulting method involved the videotaping of passing traffic and then analyzing the wheelbases of each vehicle taped to determine if the program would properly classify that vehicle.

4.1.1 Experiment Methodology

For the experiment, a video camera was set up at a right angle to Interstate 81 at an elevated location within a rest area near Ironto, Virginia. The date was December 22, 1987. From that location the camera could tape the passing traffic in both the northbound and

southbound lanes. A tripod was used to insure that there would be no camera movement during the duration of the taping, since such movement could cause analysis errors. Traffic during the one-hour period of 1:40 p.m. to 2:40 p.m. was then taped.

4.1.2 Data Analysis

That tape was then played back using a 13" monitor, and advanced until a vehicle of known wheelbase appeared in the northbound lane. That vehicle happened to be a 1984 Ford Mustang, which has a 101.5 inch wheelbase. At that point the tape was paused and the distance on the monitor between the axles was measured. That distance was used to create a scale to measure the axle spacings of all of the northbound vehicles. The same procedure, again using a Ford Mustang, was then used to create a similar scale for the southbound lane. The tape was then rewound and the analysis began.

As each vehicle passed across the monitor the tape was paused and the axle spacings measured. The measured spacings were then compared to the ranges used within the program to determine whether the vehicle would have been classified into the correct class. The result for each vehicle was then recorded as either a correct or incorrect classification. That procedure was repeated until all of the vehicles on the tape had been classified.

Due to the use of a small screen, and the amount of visual distortion common to video recordings, the spacings could only be measured to within three inches (.25 feet). This was judged to be precise enough for vehicles where a difference of three inches would not have affected classification. In those cases where it would have affected classification, the distance was measured in several consecutive video frames and an average calculated.

The measurements of certain vehicles, such as 1983-1985 Ford Mustangs, were also compared to the actual wheelbases (from *Chilton's Automotive Industries*) throughout the analysis to determine the accuracy of the experiment and to make sure that the camera had not moved.

4.2 Experimental Results

The results showed the program to be very effective in correctly classifying vehicles of all types, especially passenger cars and tractor-trailers. Those results are shown in Table 3.

Twenty-one of the thirty-one classes covered by the program data base were represented within the experimental hour of traffic. Of those not represented, four were prohibited by law, and only one, the motorcycle, could be considered as a common vehicle type. The reason that no motorcycles were encountered was probably that the day of taping was a cold and windy December day, not suitable for cycle riding. Although only two buses were included in the hour taped, those buses were of the type found to be most common in earlier field experiments, and thus the correct classification of those vehicles was important. The one 'other' vehicle was a two-axle single-unit truck with a three-axle trailer, not covered by any of the classes within the program, which would have been properly classified as a 'unknown five-axle vehicle' by the program.

Assuming the field detectors worked perfectly in measuring the number of axles and their spacings, the program would have properly classified 2474 of the 2499 vehicles that passed during the taping hour. That classification could have also been performed by one person, in a short period of time, using the software as described in the next section.

Table 3. Results of Classification Accuracy Experiment

Vehicle Type	Number Taped	Correctly Classified	Incorrectly Classified	% Correctly Classified
Motorcycles	0	0	0	0 %
Passenger Cars	2169	2154	15	99.3 %
Single-Unit Trucks				89.1 %
Class 23	47	43	4	
Class 31	6	6	0	
Class 45	2	0	2	
Buses				100 %
Class 25	1	1	0	
Class 35	1	1	0	
Cars with Trailer	15	13	2	86.7 %
Tractor-Trailers				99.2 %
Class 32	4	4	0	
Class 41	11	11	0	
Class 51	220	218	2	
Class 52	15	15	0	
Class 55	2	2	0	
Class 61	2	2	0	
Class 62	2	2	0	
Class 73	1	1	0	
Others	1	1	0	100 %
Total	2499	2474	25	99.0 %

5.0 Software Description

5.1 Software Overview

This classification program was designed for use with IBM or IBM compatible micro-computers. It has been tested on IBM (and compatible) AT's, Xt's and PC's, and also on Zenith 'laptop' portables, with favorable results. An 8087 math coprocessor is recommended but not required. Users with RGB monitors will also enjoy the color screens and prompts that the program was designed to give.

The program was designed to be 'user friendly', and those who have used the program thus far have had little or no difficulty. It progresses through a series of screens which direct the user to the mode best suited for his type of data. The first such screen asks the user to select either automatic mode (for use when the computer is directly interfaced with the detection sensors), or interactive mode (for use when data is to be entered from the user via the keyboard).

5.1.1 Automatic Mode

If the operator selects the automatic mode, prompts will follow asking him if a printout is desired, the distance between the sensors, and the number of vehicles he wishes to have classified. The computer then proceeds automatically, obtaining the required vehicle information from the input-output port. The program analyzes that data, displays the class and speed of the vehicle on the computer, and provides a printout of the class and speed if requested earlier.

After the requested number of vehicles have been classified, the user is asked if he wishes to see group and class totals. If so, screens showing the totals and average speeds of each group (car, bus, etc...), along with the totals for each class, are displayed on the monitor, and the user is asked if he wants a printout of those totals. The next prompt asks if classification of another set of vehicles is desired. If the user answers yes, the program asks whether the totals are to be reset to zero, and then returns to ask the number to be classified. If the answer is no, then the computer asks the user whether it is desired to change mode or quit. When the user requests to change mode, the computer asks whether totals are to be reset, and then asks which mode is desired.

5.1.2 Interactive Mode

If the operator selects the interactive mode, he is then asked to select either the time-based option (for entry of data in the form of time intervals) or the length-based option (for entry of data in the form of wheelbase distances). Both options begin by asking if a printout is desired.

The time-based option then asks for the distance between the detection sensors, the time interval between the detection of the the first axle at the two sensors, the number of axles, and the time intervals between the axles at either of the detection sensors.

The length-based option asks for the number of axles, the distances between the axles, and if a calculation of the speed is required. If so, the user is asked for the distance and time between two points (or the sensors).

The program then uses that information to classify the vehicle, and prints the class, speed (=Unknown if speed calculation was not requested in the length-based mode), and wheelbases of the vehicle on the monitor.

The user is then asked if he wishes to see additional information on the class of the vehicle. If the reply is yes, an information screen is displayed which lists the most common vehicle type in the class, other vehicles within the class, and vehicles of other classes which may be accidentally classified into the class.

The next prompt allows the user to do one of five options. By selecting C (for continue) the user is returned to the beginning of the option he was previously in, so that data on the next vehicle can be entered. The selection of T (for totals) results in the display of the previously mentioned total screens showing group totals, group average speeds, and class totals. The user is then asked if he wants a printout of the totals, before returning to this prompt. Selecting R (for reset) results in the resetting of the totals to zero, and a return to this prompt. Selecting M (for mode change) allows the user to change modes and reset the totals to zero if desired, while selecting Q allows the user to quit.

5.2 *Interfacing*

It must be noted that the overall classification accuracy of the system greatly depends upon the accuracy of the data collected by the detection sensors. In the previously mentioned

experiment, the detection sensors were assumed to be perfect in the measurement of the required data, where in reality such perfection is improbable.

To operate properly in automatic mode, vehicle detection sensors must be interfaced with the microcomputer such that the axle count (A), the time interval between sensors for the first axle (T0), and nine time intervals between axles (T1-T9) are supplied to the program via the input-output port. Research is presently underway here at Virginia Tech to develop such an interfacing system.

5.3 Applications

This classification system and its program can be used in many ways. It will provide needed information on the number of each type of vehicle using a portion of highway, and perform traffic counts to monitor the level of service provided. It will also provide information on the axle configurations of vehicles for use in maintenance management and planning, especially in the case of trucks, where those configurations greatly influence the stress, and wear, on highways and bridges. It also allows for the monitoring of vehicle speeds in a section of highway, and produces information on average speeds, which in recent years has influenced federal highway funding.

The program itself can be used in conjunction with other classification systems that have been created, and probably with some yet to be created. As has been shown, the program is flexible enough to be used in the field or in the office. It was also designed with future vehicles in mind. That was done through the study of present trends in automobile design, such as size reduction, and the projection of those trends into the future.

5.4 Possible Extensions

With the inclusion of an axle counter that produces a signal proportional to the weight of a passing axle (such as a piezo-electric cable), this system could be extended to include weight information. Such a system could also be used to weigh vehicles that are in motion, which could improve the enforcement of highway weight regulations. That could lead to reduced pavement maintenance, and increased pavement life.

6.0 Summary and Conclusions

This report has described in detail the theoretical similarities and differences between the ALICE and Two-Point-Time-Ratio systems of vehicle classification. It contains a review of the methodology used by the ALICE system for vehicle classification and the deficiencies of the data base of the program used. The methodology and development of an alternative program, being developed for use with the TPTR system, was then discussed at length with particular attention focused on the classification ranges used within it. An experiment has been conducted to determine the accuracy of the program and the results are given. The results prove the program to be highly accurate in the classification of all vehicle groups.

A thorough overview of the software has been given, followed by a discussion of the interfacing required for automatic operation. The uses and possible extensions of the classification system, and the program itself, have also been discussed.

It is therefore concluded that the Two-Point-Time-Ratio vehicle classification system represents a definite improvement over the popular ALICE system in the field of automated vehicle classification and speed determination. It requires only two detection sensors, covers a broader range of vehicle types, can be used interactively, is more modern, and is more accurate in classification. With a design that has been effectively utilized in China, and an ex-

perimentally tested classification logic accuracy of 99.0%, the system can be viewed as a major advance in automated vehicle classification systems.

It is also concluded that other automated classification systems could be greatly improved through the use of the classification program set forth here.

Bibliography

1. Nash, D. D., "ALICE: Automatic Length Indication and Classification Equipment, An equipment for automatically classifying vehicles and measuring their speed", *Traffic Engineering & Control*, Vol. 17 No.12 (December 1976), pp. 195-201.
2. Izadmehr, Dr. B., "Automatic Vehicle Classification System", Ph.d. Dissertation, University of Texas, 1986, pp. 109-117.
3. "Engineering Specifications and Statistics: Motor Vehicles", *Chilton's Automotive Industries*, Vol. 166 No. 3 (March 1987), pp.57-81.
4. "Engineering Specifications and Statistics: Motor Vehicles", *Chilton's Automotive Industries*, Vol. 152 No. 7 (April 1, 1975), pp.40-57.
5. "Engineering Specifications and Statistics: Motor Vehicles", *Chilton's Automotive Industries*, Vol. 150 No. 7 (April 1 1974), pp.46-68.
6. Ford Motor Company, *Ford F-Series Pickup* (Brochure #8803), August 1987, p. 19.
7. Transportation Research Board, National Research Council, *Special Report 211: Twin Trailer Trucks*, Washington D.C., 1986, pp. 212-219.

Appendix A. The CLASSIFY Classification Program

```
4 'VEHICLE CLASSIFICATION PROGRAM          BCM@1987
5 SCREEN 0,0
6 CLS :COLOR 14,1,1:CLS
7 OPEN "LPT1:" FOR OUTPUT AS #1
10 PRINT :PRINT :PRINT :PRINT :PRINT :PRINT
11 PRINT "          VEHICLE CLASSIFICATION PROGRAM"
12 PRINT :PRINT :PRINT
13 PRINT "          Developed by          "
14 PRINT "          Bernard Curtis McCullough Jr."
15 PRINT :PRINT
16 PRINT "          Department of Civil Engineering"
17 PRINT "          Virginia Polytechnic Inst. & State Univ."
18 PRINT "          Blacksburg,VA 24061"
19 PRINT "          (703) 961-7409"
20 PRINT :PRINT :PRINT :PRINT :PRINT :PRINT
22 COLOR 11,1
25 PRINT "          Press Any Key to Continue"
26 E$="" :E$=INKEY$ :IF E$="" THEN 26
30 COLOR 15,1,1 :CLS
31 PRINT :PRINT :PRINT :PRINT :PRINT
40 PRINT "PLEASE MAKE A SELECTION:"
41 PRINT :PRINT :PRINT
45 PRINT "PRESS [A] FOR AUTOMATIC MODE (AXLE DATA RECEIVED VIA ROAD SEN-
SORS)"
46 PRINT
47 PRINT "PRESS [I] FOR INTERACTIVE MODE (DATA SUPPLIED BY OPERATOR)"
48 PRINT :PRINT :PRINT
49 PRINT "          (A or I) ? ";
50 M$="" :M$=INKEY$ :IF M$="" THEN 50
51 IF M$="a" THEN M$="A"
52 IF M$="i" THEN M$="I"
53 PRINT M$
55 IF M$="A" THEN 1200
56 IF M$="I" THEN 59 ELSE 49
59 Y$=" "
```

```

60 C10=0:C20=0:C21=0:C22=0:C23=0: C24=0:C25=0:C30=0:C31=0:C32=0:C33=0:
C34=0
61 C35=0:C36=0:C40=0:C41=0:C42=0: C43=0:C44=0:C45=0:C46=0:C50=0:C51=0:
C52=0
62 C53=0:C54=0:C55=0:C60=0:C61=0: C62=0:C63=0:C64=0:C70=0:C71=0:C72=0
63 C73=0:C80=0:C81=0:C90=0:C91=0: C100=0:SC$=" "
70 IF Y$="R" THEN 72 ELSE 95
72 IF SUM=0 THEN 6005
75 COLOR 14,1 :PRINT " TOTALS RESET TO ZERO"
76 SUM=0:CYC=0:CAR=0:SUT=0:TRTR=0: BUS=0:OTHER=0
77 VCYC=0:VCAR=0:VSUT=0:VBUS=0:VTRTR=0: VOTH=0
78 NCYC=0:NCAR=0:NSUT=0:NBUS=0:NTRTR=0: NOTH=0:COLOR 15,1 :GOTO 5300
95 SUM=0:CYC=0:CAR=0:SUT=0:TRTR=0: BUS=0:OTHER=0
96 VCYC=0:VCAR=0:VSUT=0:VBUS=0:VTRTR=0: VOTH=0
97 NCYC=0:NCAR=0:NSUT=0:NBUS=0:NTRTR=0: NOTH=0
100 M$="1" :CLS :COLOR 10,1,1
101 PRINT " INTERACTIVE MODE"
102 COLOR 15,1 :PRINT :PRINT :PRINT :PRINT
103 PRINT "PLEASE MAKE A SELECTION:"
104 PRINT :PRINT :PRINT
105 PRINT "PRESS [T] FOR TIME-BASED OPTION (ENTRY OF TIME INTERVAL DATA)"
106 PRINT
107 PRINT "PRESS [W] FOR LENGTH-BASED OPTION (ENTRY OF WHEELBASE LENGTHS)"
108 PRINT :PRINT :PRINT
109 PRINT " (T or W) ? ";
110 O$="" :O$=INKEY$ :IF O$="" THEN 110
111 IF O$="t" THEN O$="T"
112 IF O$="w" THEN O$="W"
113 PRINT O$
115 IF O$="T" THEN 500
116 IF O$="W" THEN 800 ELSE 109
500 O$="T" :CLS: COLOR 10,1,1
501 PRINT " TIME-BASED INTERACTIVE MODE"
502 COLOR 15,1 :PRINT :PRINT :PRINT :PRINT
505 PRINT "WOULD YOU LIKE A PRINTOUT OF RESULTS ? (Y or N) ";
506 P$="" :P$=INKEY$ :IF P$="" THEN 506
507 IF P$="y" THEN P$="Y"
508 IF P$="n" THEN P$="N"
509 PRINT P$
520 INPUT "ENTER DISTANCE BETWEEN SENSORS IN FEET. ",D
530 W1=0:W2=0:W3=0:W4=0:W5=0: W6=0:W7=0:W8=0:W9=0:V=0:VMPH=0
531 T0#=0:T1#=0:T2#=0:T3#=0:T4#=0: T5#=0:T6#=0:T7#=0:T8#=0:T9#=0
540 INPUT "ENTER TIME INTERVAL BETWEEN SENSORS FOR FIRST AXLE IN SECONDS.
",T0#
560 INPUT "ENTER NUMBER OF AXLES. ",A%
565 IF A%=1 THEN 1400
570 PRINT "FOR A SELECTED SENSOR ENTER THE FOLLOWING TIME INTERVALS";
571 PRINT "IN SECONDS:"
580 INPUT "BETWEEN FIRST (FRONT) AND SECOND AXLES ? ",T1#
585 IF A%=2 THEN 700
590 INPUT "BETWEEN SECOND AND THIRD AXLES ? ",T2#
595 IF A%=3 THEN 700
600 INPUT "BETWEEN THIRD AND FOURTH AXLES ? ",T3#
605 IF A%=4 THEN 700
610 INPUT "BETWEEN FOURTH AND FIFTH AXLES ? ",T4#
615 IF A%=5 THEN 700

```

```

620 INPUT "BETWEEN FIFTH AND SIXTH AXLES ? ",T5#
625 IF A%=6 THEN 700
630 INPUT "BETWEEN SIXTH AND SEVENTH AXLES ? ",T6#
635 IF A%=7 THEN 700
640 INPUT "BETWEEN SEVENTH AND EIGHTH AXLES ? ",T7#
645 IF A%=8 THEN 700
650 INPUT "BETWEEN EIGHTH AND NINTH AXLES ? ",T8#
655 IF A%=9 THEN 700
660 INPUT "BETWEEN NINTH AND TENTH AXLES ? ",T9#
665 IF A% >= 10 THEN 700
700 GOTO 1500
800 O$="W" :CLS :COLOR 10,1,1
801 PRINT "                LENGTH-BASED INTERACTIVE MODE"
802 COLOR 15,1 :PRINT :PRINT :PRINT :PRINT
805 PRINT "WOULD YOU LIKE A PRINTOUT OF RESULTS ? (Y or N) ";
806 P$="" :P$=INKEY$ :IF P$="" THEN 806
807 IF P$="y" THEN P$="Y"
808 IF P$="n" THEN P$="N"
809 PRINT P$
820 INPUT "ENTER NUMBER OF AXLES. ",A%
830 W1=0:W2=0:W3=0:W4=0:W5=0: W6=0:W7=0:W8=0:W9=0:V=0:VMPH=0
831 T0#=0:T1#=0:T2#=0:T3#=0:T4#=0: T5#=0:T6#=0:T7#=0:T8#=0:T9#=0
835 IF A%=1 THEN 1400
855 PRINT "ENTER THE FOLLOWING WHEELBASE LENGTHS IN FEET: "
860 INPUT "BETWEEN FIRST (FRONT) AND SECOND AXLES ? ",W1
865 IF A%=2 THEN 960
870 INPUT "BETWEEN SECOND AND THIRD AXLES ? ",W2
875 IF A%=3 THEN 960
880 INPUT "BETWEEN THIRD AND FOURTH AXLES ? ",W3
885 IF A%=4 THEN 960
890 INPUT "BETWEEN FOURTH AND FIFTH AXLES ? ",W4
895 IF A%=5 THEN 960
900 INPUT "BETWEEN FIFTH AND SIXTH AXLES ? ",W5
905 IF A%=6 THEN 960
910 INPUT "BETWEEN SIXTH AND SEVENTH AXLES ? ",W6
915 IF A%=7 THEN 960
920 INPUT "BETWEEN SEVENTH AND EIGHTH AXLES ? ",W7
925 IF A%=8 THEN 960
930 INPUT "BETWEEN EIGHTH AND NINTH AXLES ? ",W8
935 IF A%=9 THEN 960
940 INPUT "BETWEEN NINTH AND TENTH AXLES ? ",W9
960 PRINT "DO YOU WISH TO CALCULATE SPEED OF VEHICLE ? (Y or N) ";
961 SC$="" :SC$=INKEY$ :IF SC$="" THEN 961
962 IF SC$="y" THEN SC$="Y"
963 IF SC$="n" THEN SC$="N"
964 PRINT SC$
965 IF SC$="N" THEN 2000
970 IF SC$="Y" THEN 975 ELSE 960
975 INPUT "ENTER DISTANCE BETWEEN POINTS (SENSORS) IN FEET. ",D
980 INPUT "ENTER TIME INTERVAL BETWEEN POINTS (SENSORS) IN SECONDS. ",T0#
985 GOTO 1500
1200                                C10=0:C20=0:C21=0:C22=0:C23=0:C24=
0:C25=0:C30=0:C31=0:C32=0:C33=0:C34=0
1201                                C35=0:C36=0:C40=0:C41=0:C42=0:C43=
0:C44=0:C45=0:C46=0:C50=0:C51=0:C52=0

```

```

1202                                     C53 = 0:C54 = 0:C55 = 0:C60 = 0:C61 = 0:
C62 = 0:C63 = 0:C64 = 0:C70 = 0:C71 = 0:C72 = 0
1203 C73 = 0:C80 = 0:C81 = 0:C90 = 0:C91 = 0: C100 = 0:N = 0
1204 SUM = 0:CYC = 0:CAR = 0:SUT = 0:TRTR = 0: BUS = 0:OTHR = 0
1205 VCYC = 0:VCAR = 0:VSUT = 0:VBUS = 0: VTRTR = 0:VOTH = 0
1206 NCYC = 0:NCAR = 0:NSUT = 0:NBUS = 0: NTRTR = 0:NOTH = 0
1207 M$ = "A" :CLS :COLOR 10,1,1
1208 PRINT "                                     AUTOMATIC MODE"
1209 COLOR 15,1 :PRINT :PRINT :PRINT :PRINT
1210 PRINT "WOULD YOU LIKE A PRINTOUT OF RESULTS ? (Y or N) ";
1211 P$ = "" :P$ = INKEY$ :IF P$ = "" THEN 1211
1212 IF P$ = "y" THEN P$ = "Y"
1213 IF P$ = "n" THEN P$ = "N"
1214 PRINT P$
1220 INPUT "ENTER DISTANCE BETWEEN SENSORS IN FEET. ",D
1250 INPUT "HOW MANY VEHICLES DO YOU WISH TO CLASSIFY ? ",SAMSIZ%
1252 IF SAMSIZ% = 0 THEN 5101
1255 SUM = 0:N = 0
1260 N = N + 1
1270 W1 = 0:W2 = 0:W3 = 0:W4 = 0:W5 = 0: W6 = 0:W7 = 0:W8 = 0:W9 = 0
1271 T0# = 0:T1# = 0:T2# = 0:T3# = 0:T4# = 0: T5# = 0:T6# = 0:T7# = 0:T8# = 0:T9# = 0
1280 INPUT A%
1285 INPUT T0#,T1#,T2#,T3#,T4#,T5#,T6#,T7#,T8#,T9#
1290 IF A% > 1 THEN 1500
1400 C$ = "ERROR - ONLY 1 AXLE DETECTED - CANNOT CLASSIFY"
1405 C10 = C10 + 1 :G = 10 :GOTO 4900
1500 V = D/T0#
1505 VMPH = V*(3600/5280)
1600 IF M$ = "I" AND O$ = "W" THEN 2000
1601 W1 = V*T1#
1602 W2 = V*T2#
1603 W3 = V*T3#
1604 W4 = V*T4#
1605 W5 = V*T5#
1606 W6 = V*T6#
1607 W7 = V*T7#
1608 W8 = V*T8#
1609 W9 = V*T9#
2000 IF A% > = 10 THEN 4500
2001 C$ = "":MCV$ = "":OCV$ = "":NOTE = 1: WVC$ = "":WVC2$ = " "
2005 ON A% GOTO 1400,2010,2100,2300,2700,3200,3600,4000,4300
2010 IF W1 > = 3 AND W1 < 6 THEN 2011 ELSE 2020
2011 C$ = " MOTORCYCLE"
2012 MCV$ = " Motorcycle"
2013 OCV$ = " None" :WVC$ = " None"
2018 C24 = C24 + 1 :G = 24 :GOTO 4900
2020 IF W1 > = 6 AND W1 < = 9 THEN 2021 ELSE 2030
2021 C$ = " PASSENGER CAR Class"
2022 MCV$ = " Small (Compact) or Midsize Car"
2023 OCV$ = " Small Pickup Trucks, Jeeps"
2024 WVC$ = " None"
2028 C21 = C21 + 1 :G = 21 :GOTO 4910
2030 IF W1 > 9 AND W1 < 12.25 THEN 2031 ELSE 2040
2031 C$ = " LARGE PASSENGER CAR Class"
2032 MCV$ = " Large Car"
2033 OCV$ = " Pickup Trucks, Minibuses, Vans, Blazers, Farm Tractors"

```

2034 WVC\$ = " Short (12'-20') Single-Unit Trucks"
 2038 C22 = C22 + 1 :G=22 :GOTO 4910
 2040 IF W1 > = 12.25 AND W1 < = 25 THEN 2041 ELSE 2050
 2041 C\$ = " TWO-AXLE SINGLE-UNIT TRUCK Class"
 2042 MCV\$ = " Two-Axle Single-Unit Truck"
 2043 OCV\$ = " Recreational Vehicles (RV's), Conventional Schoolbuses"
 2044 WVC\$ = " Limousines, Longbed 'Crewcab' Pickups, Short Buses"
 2048 C23 = C23 + 1 :G=23 :GOTO 4920
 2050 IF W1 > 25 AND W1 < = 35 THEN 2051 ELSE 2060
 2051 C\$ = " TWO-AXLE BUS Class"
 2052 MCV\$ = " Two-Axle Bus (Transit Type)"
 2053 OCV\$ = " None"
 2054 WVC\$ = " Longer (35' +) Two-Axle Single-Unit Trucks"
 2058 C25 = C25 + 1 :G=25 :GOTO 4930
 2060 C\$ = " UNKNOWN TWO-AXLE VEHICLE"
 2068 C20 = C20 + 1 :G=20 :NOTE=0 :GOTO 4950
 2100 IF W1 > = 8 AND W1 < = 25 THEN 2101 ELSE 2110
 2101 IF W2 > = 2 AND W2 < = 6 THEN 2102 ELSE 2110
 2102 C\$ = " THREE-AXLE SINGLE-UNIT TRUCK Class"
 2104 MCV\$ = " Three-Axle Single-Unit Truck"
 2105 OCV\$ = " Three-Axle Recreational Vehicles (RV's)"
 2106 WVC\$ = " None"
 2108 C31 = C31 + 1 :G=31 :GOTO 4920
 2110 IF W1 > = 8 AND W1 < = 20 THEN 2111 ELSE 2120
 2111 IF W2 > = 20 AND W2 < = 45 THEN 2112 ELSE 2120
 2112 C\$ = " TWO-AXLE TRACTOR WITH SINGLE-AXLE SEMITRAILER"
 2113 MCV\$ = " Two-Axle Tractor with Single-Axle Semitrailer"
 2114 OCV\$ = " None"
 2115 WVC\$ = " Car, Pickup, or Van with 20' + Single-Axle Trailer"
 2118 C32 = C32 + 1 :G=32 :GOTO 4940
 2120 IF W1 > = 6 AND W1 < = 12.25 THEN 2121 ELSE 2130
 2121 IF W2 > 6 AND W2 < 20 THEN 2122 ELSE 2130
 2122 C\$ = " CAR WITH SINGLE-AXLE TRAILER Class"
 2123 MCV\$ = " Car with Single-Axle Trailer"
 2124 OCV\$ = " Pickup or Van with Single-Axle Trailer"
 2125 WVC\$ = " Two-Axle Tractor with 10'-25' Single-Axle Semitrailer"
 2128 C33 = C33 + 1 :G=33 :GOTO 4910
 2130 IF W1 > = 3 AND W1 < 6 THEN 2131 ELSE 2140
 2131 IF W2 > = 3 AND W2 < = 7 THEN 2132 ELSE 2140
 2132 C\$ = " MOTORCYCLE WITH TRAILER"
 2133 MCV\$ = " Motorcycle with Trailer"
 2134 OCV\$ = " None" :WVC\$ = " None"
 2138 C34 = C34 + 1 :G=34 :GOTO 4900
 2140 IF W1 > 25 AND W1 < = 35 THEN 2141 ELSE 2150
 2141 IF W2 > = 2 AND W2 < = 6 THEN 2142 ELSE 2150
 2142 C\$ = " THREE-AXLE BUS"
 2143 MCV\$ = " Three-Axle Bus (Transit Type)"
 2144 OCV\$ = " None"
 2145 WVC\$ = " Longer (35' +) Three-Axle Single-Unit Trucks"
 2148 C35 = C35 + 1 :G=35 :GOTO 4930
 2150 IF W1 > 12.25 AND W1 < = 25 THEN 2151 ELSE 2160
 2151 IF W2 > 6 AND W2 < 20 THEN 2152 ELSE 2160
 2152 C\$ = " TWO-AXLE SINGLE-UNIT TRUCK WITH SINGLE-AXLE TRAILER"
 2153 MCV\$ = " Two-Axle Single-Unit Truck with Single-Axle Trailer"
 2154 OCV\$ = " None"
 2155 WVC\$ = " Two-Axle Tractor with 10'-25' Single-Axle Semitrailer"

2158 C36=C36+1 :G=36 :GOTO 4920
2160 C\$=" UNKNOWN THREE-AXLE VEHICLE"
2161 C30=C30+1 :G=30 :NOTE=0 :GOTO 4950
2300 IF W1 >= 8 AND W1 <= 20 THEN 2301 ELSE 2310
2301 IF W2 > 15 AND W2 <= 45 THEN 2302 ELSE 2310
2302 IF W3 >= 2 AND W3 <= 12.5 THEN 2303 ELSE 2310
2303 C\$=" TWO-AXLE TRACTOR WITH TWO-AXLE SEMITRAILER"
2304 MCV\$=" Two-Axle Tractor with Two-Axle Semitrailer"
2305 OCV\$=" None"
2306 WVC\$=" Two-Axle SU Truck with Long (25' +) Two-Axle Trailer"
2308 C41=C41+1 :G=41 :GOTO 4940
2310 IF W1 >= 8 AND W1 <= 20 THEN 2311 ELSE 2320
2311 IF W2 >= 2 AND W2 <= 6 THEN 2312 ELSE 2320
2312 IF W3 > 15 AND W3 <= 45 THEN 2313 ELSE 2320
2313 C\$=" THREE-AXLE TRACTOR WITH SINGLE-AXLE SEMITRAILER"
2314 MCV\$=" Three-Axle Tractor with Single-Axle Semitrailer"
2315 OCV\$=" None"
2316 WVC\$=" Three-Axle SU Truck with Long (25' +) Single-Axle Trailer"
2318 C42=C42+1 :G=42 :GOTO 4940
2320 IF W1 >= 8 AND W1 <= 25 THEN 2321 ELSE 2330
2321 IF W2 >= 2 AND W2 <= 6 THEN 2322 ELSE 2330
2322 IF W3 >= 2 AND W3 <= 6 THEN 2323 ELSE 2330
2323 C\$=" FOUR-AXLE SINGLE-UNIT TRUCK"
2324 MCV\$=" Four-Axle Single-Unit Truck"
2325 OCV\$=" None" :WVC\$=" None"
2328 C43=C43+1 :G=43 :GOTO 4920
2330 IF W1 >= 6 AND W1 <= 12.25 THEN 2331 ELSE 2340
2331 IF W2 > 6 AND W2 <= 15 THEN 2332 ELSE 2340
2332 IF W3 >= 2 AND W3 <= 6 THEN 2333 ELSE 2340
2333 C\$=" CAR WITH TWO-AXLE TRAILER"
2334 MCV\$=" Car with Two-Axle Trailer"
2335 OCV\$=" Pickup or Van with Two-Axle Trailer"
2336 WVC\$=" Short (12'-20') SU Truck with Two-Axle Trailer"
2337 WVC2\$=" Two-Axle Tractor with 10'-20' Two-Axle Semitrailer"
2338 C44=C44+1 :G=44 :NOTE=2 :GOTO 4910
2340 IF W1 > 12.25 AND W1 <= 25 THEN 2341 ELSE 2350
2341 IF W2 > 6 AND W2 <= 15 THEN 2342 ELSE 2350
2342 IF W3 >= 2 AND W3 <= 6 THEN 2343 ELSE 2343
2343 IF W2 > 6 AND W2 <= 12 THEN 2344 ELSE 2350
2344 IF W3 > 7 AND W3 <= 20 THEN 2345 ELSE 2350
2345 C\$=" TWO-AXLE SINGLE-UNIT TRUCK WITH TWO-AXLE TRAILER"
2346 MCV\$=" Two-Axle Single-Unit Truck with Two-Axle Trailer"
2347 OCV\$=" None"
2348 WVC\$=" Two-Axle Tractor with 10'-20' Two-Axle Semitrailer"
2349 C45=C45+1 :G=45 :GOTO 4920
2350 IF W1 >= 8 AND W1 <= 25 THEN 2351 ELSE 2360
2351 IF W2 >= 2 AND W2 <= 6 THEN 2352 ELSE 2360
2352 IF W3 > 6 AND W3 <= 15 THEN 2353 ELSE 2360
2353 C\$=" THREE-AXLE SINGLE-UNIT TRUCK WITH SINGLE-AXLE TRAILER"
2354 MCV\$=" Three-Axle Single-Unit Truck with Single-Axle Trailer"
2355 OCV\$=" None"
2356 WVC\$=" Three-Axle Tractor with 10'-20' Single-Axle Semitrailer"
2357 C46=C46+1 :G=46 :GOTO 4920
2360 C\$=" UNKNOWN FOUR-AXLE VEHICLE"
2361 C40=C40+1 :G=40 :NOTE=0 :GOTO 4950
2700 IF W1 >= 8 AND W1 <= 25 THEN 2701 ELSE 2720

```

2701 IF W2 >= 2 AND W2 <= 6 THEN 2702 ELSE 2720
2702 IF W3 > 15 AND W3 <= 45 THEN 2703 ELSE 2720
2703 IF W4 >= 2 AND W4 <= 12.5 THEN 2704 ELSE 2720
2704 C$=" THREE-AXLE TRACTOR WITH TWO-AXLE SEMITRAILER"
2705 MCV$=" Three-Axle Tractor with Two-Axle Semitrailer"
2706 OCV$=" None"
2707 WVC$=" Three-Axle SU Truck with Long (25' +) Two-Axle Trailer"
2708 C51=C51+1 :G=51 :GOTO 4940
2720 IF W1 >= 8 AND W2 <= 25 THEN 2721 ELSE 2740
2721 IF W2 >= 11 AND W2 <= 36 THEN 2722 ELSE 2740
2722 IF W3 > 6 AND W3 <= 20 THEN 2723 ELSE 2740
2723 IF W4 >= 7 AND W4 <= 35 THEN 2724 ELSE 2740
2724 C$=" TWO-AXLE TRACTOR WITH TWIN SHORT TRAILERS"
2725 MCV$=" Two-Axle Tractor with Two Short 25'-30' Trailers"
2726 OCV$=" None" :WVC$=" None"
2728 C52=C52+1 :G=52 :GOTO 4940
2740 IF W1 >= 8 AND W1 <= 25 THEN 2741 ELSE 2760
2741 IF W2 >= 2 AND W2 <= 6 THEN 2742 ELSE 2760
2742 IF W3 > 6 AND W3 <= 15 THEN 2743 ELSE 2760
2743 IF W4 >= 2 AND W4 <= 6 THEN 2746 ELSE 2744
2744 IF W3 > 6 AND W3 <= 12 THEN 2745 ELSE 2760
2745 IF W4 > 7 AND W4 <= 20 THEN 2746 ELSE 2760
2746 C$=" THREE-AXLE SINGLE-UNIT TRUCK WITH TWO-AXLE TRAILER"
2747 MCV$=" Three-Axle Single-Unit Truck with Two-Axle Trailer" :OCV$=" None"
2748 WVC$=" Three-Axle Tractor with 10'-20' Two-Axle Semitrailer"
2749 C53=C53+1 :G=53 :GOTO 4920
2760 IF W1 >= 8 AND W1 <= 25 THEN 2761 ELSE 2780
2761 IF W2 >= 2 AND W2 <= 6 THEN 2762 ELSE 2780
2762 IF W3 >= 2 AND W3 <= 6 THEN 2763 ELSE 2780
2763 IF W4 > 6 AND W4 <= 15 THEN 2764 ELSE 2780
2764 C$=" FOUR-AXLE SINGLE-UNIT TRUCK WITH SINGLE-AXLE TRAILER"
2765 MCV$=" Four-Axle Single-Unit Truck with Single-Axle Trailer"
2766 OCV$=" None" :WVC$=" None"
2768 C54=C54+1 :G=54 :GOTO 4920
2780 IF W1 >= 8 AND W1 <= 20 THEN 2781 ELSE 2800
2781 IF W2 > 11 AND W2 <= 42 THEN 2782 ELSE 2800
2782 IF W3 >= 2 AND W3 <= 6 THEN 2783 ELSE 2800
2783 IF W4 >= 2 AND W4 <= 6 THEN 2784 ELSE 2800
2784 C$=" TWO-AXLE TRACTOR WITH THREE-AXLE SEMITRAILER"
2785 MCV$=" Two-Axle Tractor with Three-Axle Semitrailer"
2786 OCV$=" None"
2787 WVC$=" Two-Axle SU Truck with Long (25' +) Three-Axle Trailer"
2788 C55=C55+1 :G=55 :GOTO 4940
2800 C$=" UNKNOWN FIVE-AXLE VEHICLE"
2801 C50=C50+1 :G=50 :NOTE=0 :GOTO 4950
3200 IF W1 >= 8 AND W1 <= 25 THEN 3201 ELSE 3300
3201 IF W2 >= 2 AND W2 <= 6 THEN 3202 ELSE 3220
3202 IF W3 >= 11 AND W3 <= 42 THEN 3203 ELSE 3220
3203 IF W4 >= 2 AND W4 <= 6 THEN 3204 ELSE 3220
3204 IF W5 >= 2 AND W5 <= 6 THEN 3205 ELSE 3220
3205 C$=" THREE-AXLE TRACTOR WITH THREE-AXLE SEMITRAILER"
3206 MCV$=" Three-Axle Tractor with Three-Axle Semitrailer"
3207 OCV$=" None" :WVC$=" None"
3208 C61=C61+1 :G=61 :GOTO 4940
3220 IF W2 >= 2 AND W2 <= 6 THEN 3221 ELSE 3240
3221 IF W3 >= 11 AND W3 <= 36 THEN 3222 ELSE 3240

```

```

3222 IF W4 > =6 AND W4 < =20 THEN 3223 ELSE 3240
3223 IF W5 > =7 AND W5 < =35 THEN 3224 ELSE 3240
3224 C$=" THREE-AXLE TRACTOR WITH TWIN SHORT TRAILERS"
3225 MCV$=" Three-Axle Tractor with Two Short 25'-30' Trailers"
3226 OCV$=" None" :WVC$=" None"
3228 C62=C62+1 :G=62 :GOTO 4940
3240 IF W2 > 2 AND W2 < 6 THEN 3241 ELSE 3280
3241 IF W3 > 2 AND W3 < 6 THEN 3242 ELSE 3280
3242 IF W4 > 6 AND W4 < 15 THEN 3243 ELSE 3280
3243 IF W5 > 2 AND W5 < 6 THEN 3246 ELSE 3244
3244 IF W4 > 6 AND W4 < 12 THEN 3245 ELSE 3280
3245 IF W5 > 7 AND W5 < 20 THEN 3246 ELSE 3280
3246 C$=" FOUR-AXLE SINGLE-UNIT TRUCK WITH TWO-AXLE TRAILER"
3247 MCV$=" Four-Axle Single-Unit Truck with Two-Axle Trailer"
3248 OCV$=" None" :WVC$=" None"
3249 C63=C63+1 :G=63 :GOTO 4920
3280 IF W2 > =2 AND W2 < =6 THEN 3281 ELSE 3300
3281 IF W3 > =2 AND W3 < =6 THEN 3282 ELSE 3300
3282 IF W4 > 15 AND W4 < =45 THEN 3283 ELSE 3300
3283 IF W5 > =2 AND W5 < =12.5 THEN 3284 ELSE 3300
3284 C$=" FOUR-AXLE TRACTOR WITH TWO-AXLE SEMITRAILER"
3285 MCV$=" Four-Axle Tractor with Two-Axle Semitrailer"
3286 OCV$=" None" :WVC$=" None"
3287 C64=C64+1 :G=64 :GOTO 4940
3300 C$=" UNKNOWN SIX-AXLE VEHICLE"
3301 C60=C60+1 :G=60 :NOTE=0 :GOTO 4950
3600 IF W1 > =8 AND W1 < =25 THEN 3601 ELSE 3740
3601 IF W2 > =2 AND W2 < =6 THEN 3602 ELSE 3620
3602 IF W3 > =11 AND W3 < =45 THEN 3603 ELSE 3620
3603 IF W4 > =2 AND W4 < =6 THEN 3604 ELSE 3620
3604 IF W5 > =7 AND W5 < =15 THEN 3605 ELSE 3620
3605 IF W6 > =11 AND W6 < =25 THEN 3606 ELSE 3620
3606 C$=" 'ROCKY MNT. TWINTRAILER'"
3607 MCV$=" 3-Axle Tractor with Two Semitrailers (one 40' + , one 25'-30')"
3608 OCV$=" None" :WVC$=" None"
3609 C71=C71+1 :G=71 :GOTO 4940
3620 IF W1 > =8 AND W1 < =20 THEN 3621 ELSE 3640
3621 IF W2 > =11 AND W2 < =45 THEN 3622 ELSE 3640
3622 IF W3 > =7 AND W3 < =15 THEN 3623 ELSE 3640
3623 IF W4 > =11 AND W4 < =25 THEN 3624 ELSE 3640
3624 IF W5 > =7 AND W5 < =15 THEN 3625 ELSE 3640
3625 IF W6 > =11 AND W6 < =25 THEN 3626 ELSE 3640
3626 C$=" TWO-AXLE TRACTOR WITH THREE TRAILERS"
3627 MCV$=" 2-Axle Tractor with Three Semitrailers (one 40' + , two 25'-30')"
3628 OCV$=" None" :WVC$=" None"
3629 C72=C72+1 :G=72 :GOTO 4940
3640 IF W1 > =8 AND W1 < =25 THEN 3641 ELSE 3740
3641 IF W2 > =2 AND W2 < =6 THEN 3642 ELSE 3740
3642 IF W3 > =2 AND W3 < =6 THEN 3643 ELSE 3740
3643 IF W4 > 11 AND W4 < =42 THEN 3644 ELSE 3740
3644 IF W5 > =2 AND W5 < =6 THEN 3645 ELSE 3740
3645 IF W5 > =2 AND W5 < =6 THEN 3646 ELSE 3740
3646 C$=" FOUR-AXLE TRACTOR WITH THREE-AXLE SEMITRAILER"
3647 MCV$=" Four-Axle Tractor with Three-Axle Semitrailer"
3648 OCV$=" None" :WVC$=" None"
3649 C73=C73+1 :G=73 :GOTO 4940

```

```

3740 C$=" UNKNOWN SEVEN-AXLE VEHICLE"
3741 C70=C70+1 :G=70 :NOTE=0 :GOTO 4950
4000 IF W1>=8 AND W1<=25 THEN 4001 ELSE 4020
4001 IF W2>=2 AND W2<=6 THEN 4002 ELSE 4020
4002 IF W3>=11 AND W3<=45 THEN 4003 ELSE 4020
4003 IF W4>=7 AND W4<=15 THEN 4004 ELSE 4020
4004 IF W5>=11 AND W5<=25 THEN 4005 ELSE 4020
4005 IF W6>=7 AND W6<=15 THEN 4006 ELSE 4020
4006 IF W7>=11 AND W7<=25 THEN 4007 ELSE 4020
4007 C$=" THREE-AXLE TRACTOR WITH THREE TRAILERS"
4008 MCV$=" 3-Axle Tractor with Three Semitrailers (one 40' + , two 25'-30)"
4009 OCV$=" None" :WVC$=" None"
4010 C81=C81+1 :G=81 :GOTO 4940
4020 C$=" UNKNOWN EIGHT-AXLE VEHICLE"
4021 C80=C80+1 :G=80 :NOTE=0 :GOTO 4950
4300 IF W1>=8 AND W1<=25 THEN 4302 ELSE 4380
4302 IF W2>=2 AND W2<=6 THEN 4304 ELSE 4380
4304 IF W3>=11 AND W3<=45 THEN 4306 ELSE 4380
4306 IF W4>=2 AND W4<=12.5 THEN 4308 ELSE 4380
4308 IF W5>=7 AND W5<=15 THEN 4310 ELSE 4380
4310 IF W6>=2 AND W6<=6 THEN 4312 ELSE 4380
4312 IF W7>=11 AND W7<=45 THEN 4314 ELSE 4380
4314 IF W8>=2 AND W8<=6 THEN 4316 ELSE 4380
4316 C$=" 'TURNPIKE DOUBLE' TRACTOR-TRAILER"
4318 MCV$=" 3-Axle Tractor with Two 2-Axle Semitrailers and a 2-Axle Dolly"
4320 OCV$=" None" :WVC$=" None"
4322 C91=C91+1 :G=91 :GOTO 4940
4380 C$=" UNKNOWN NINE-AXLE VEHICLE"
4381 C90=C90+1 :G=90 :NOTE=0 :GOTO 4950
4500 C$=" UNKNOWN 10+ AXLE VEHICLE"
4501 C100=C100+1 :G=100 :NOTE=0 :GOTO 4950
4900 IF SC$="N" THEN 4980 ELSE 4901
4901 VCYC=VCYC+VMPH :NCYC=NCYC+1
4902 GOTO 4980
4910 IF SC$="N" THEN 4980 ELSE 4911
4911 VCAR=VCAR+VMPH :NCAR=NCAR+1
4912 GOTO 4980
4920 IF SC$="N" THEN 4980 ELSE 4921
4921 VSUT=VSUT+VMPH :NSUT=NSUT+1
4922 GOTO 4980
4930 IF SC$="N" THEN 4980 ELSE 4931
4931 VBUS=VBUS+VMPH :NBUS=NBUS+1
4932 GOTO 4980
4940 IF SC$="N" THEN 4980 ELSE 4941
4941 VTRTR=VTRTR+VMPH :NTRTR=NTRTR+1
4942 GOTO 4980
4950 IF SC$="N" THEN 4980 ELSE 4951
4951 VOTH=VOTH+VMPH :NOTH=NOTH+1
4980 CYC=C24+C34
4981 CAR=C21+C22+C33+C44
4982 SUT=C23+C31+C43+C36+C45+C46+C53+C54+C63
4983 BUS=C25+C35
4984
TRTR=C32+C41+C42+C51+C52+C55+C61+C62+C64+C71+C72+C73+C81+C91
4985 OTHR=C10+C20+C30+C40+C50+C60+C70+C80+C90+C100
4986 SUM=CYC+CAR+SUT+BUS+TRTR+OTHR

```

```

5000 COLOR 14,1 :PRINT
5001 PRINT C$;
5004 IF P$="Y" THEN 5005 ELSE 5008
5005 PRINT #1," "
5006 PRINT #1,C$;
5008 IF A%=1 THEN 5011
5010 IF M$="I" AND O$="W" AND SC$="N" THEN 5011 ELSE 5020
5011 PRINT " V=Unknown"
5012 IF P$="Y" THEN PRINT #1," V=Unknown"
5013 GOTO 5058
5020 PRINT " V=";
5021 PRINT USING "##.#";VMPH;
5022 PRINT " MPH."
5024 IF P$="Y" THEN 5025 ELSE 5035
5025 PRINT #1," V=";
5026 PRINT #1,USING "##.#";VMPH;
5027 PRINT #1," MPH."
5035 GOTO 5060
5058 IF A%=1 THEN 5095
5060 IF A%=2 THEN 5061 ELSE 5070
5061 PRINT " Wheelbase Length (ft): ";
5062 PRINT USING "##.##";W1
5063 IF P$="Y" THEN 5064 ELSE 5066
5064 PRINT #1," Wheelbase Length (ft): ";
5065 PRINT #1,USING "##.##";W1
5066 GOTO 5095
5070 PRINT " Wheelbase Lengths (ft): ";
5071 PRINT USING "##.##";W1;
5072 IF A% >= 3 THEN PRINT USING " ##.##";W2;
5073 IF A% >= 4 THEN PRINT USING " ##.##";W3;
5074 IF A% >= 5 THEN PRINT USING " ##.##";W4;
5075 IF A% >= 6 THEN PRINT USING " ##.##";W5;
5076 IF A% >= 7 THEN PRINT USING " ##.##";W6;
5077 IF A% >= 8 THEN PRINT USING " ##.##";W7;
5078 IF A% >= 9 THEN PRINT USING " ##.##";W8;
5079 IF A% >= 10 THEN PRINT USING " ##.##";W9;
5080 IF P$="Y" THEN 5081 ELSE 5094
5081 PRINT #1," Wheelbase Lengths (ft): ";
5082 PRINT USING "##.##";W1;
5083 IF A% >= 3 THEN PRINT #1,USING " ##.##";W2;
5084 IF A% >= 4 THEN PRINT #1,USING " ##.##";W3;
5085 IF A% >= 5 THEN PRINT #1,USING " ##.##";W4;
5086 IF A% >= 6 THEN PRINT #1,USING " ##.##";W5;
5087 IF A% >= 7 THEN PRINT #1,USING " ##.##";W6;
5088 IF A% >= 8 THEN PRINT #1,USING " ##.##";W7;
5089 IF A% >= 9 THEN PRINT #1,USING " ##.##";W8;
5090 IF A% >= 10 THEN PRINT #1,USING " ##.##";W9;
5091 PRINT #1," "
5094 PRINT " "
5095 PRINT
5097 COLOR 15,1
5098 IF M$="A" THEN 5100 ELSE 5200
5100 IF N<SAMSIZ% THEN 1260
5101 COLOR 14,1
5102 PRINT "FINISHED: ";SAMSIZ%;" VEHICLES CLASSIFIED"
5103 COLOR 15,1

```

```

5105 PRINT "DO YOU WISH TO SEE VEHICLE TOTALS BY TYPE ? (Y or N) ";
5106 T$="" :T$=INKEY$ :IF T$="" THEN 5106
5107 IF T$="y" THEN T$="Y"
5108 IF T$="n" THEN T$="N"
5109 PRINT T$
5110 IF T$="Y" THEN 6000
5111 IF T$="N" THEN 5120 ELSE 5105
5120 PRINT "DO YOU WISH TO DO ANOTHER SET OF VEHICLES ? (Y or N) ";
5121 ASET$="" :ASET$=INKEY$ :IF ASET$="" THEN 5121
5122 IF ASET$="y" THEN ASET$="Y"
5123 IF ASET$="n" THEN ASET$="N"
5124 PRINT ASET$
5125 IF ASET$="Y" THEN 5128
5126 IF ASET$="N" THEN 5140 ELSE 5120
5128 IF SUM=0 THEN GOTO 1207
5130 PRINT "RESET TOTALS TO ZERO ? (Y or N) ";
5131 RES$="" :RES$=INKEY$ :IF RES$="" THEN 5131
5132 IF RES$="y" THEN RES$="Y"
5133 IF RES$="n" THEN RES$="N"
5134 PRINT RES$
5135 IF RES$="Y" THEN 1200
5136 IF RES$="N" THEN 1207 ELSE 5130
5140 PRINT "PRESS [M] TO CHANGE MODE OR [Q] TO QUIT. ";
5141 Y$="" :Y$=INKEY$ :IF Y$="" THEN 5141
5142 IF Y$="m" THEN Y$="M"
5143 IF Y$="q" THEN Y$="Q"
5144 PRINT Y$
5145 IF Y$="M" THEN 5148
5146 IF Y$="Q" THEN END ELSE 5140
5148 IF SUM=0 THEN 100
5150 M$="I" :PRINT "RESET TOTALS TO ZERO ? (Y or N) ";
5151 REST$="" :REST$=INKEY$ :IF REST$="" THEN 5151
5152 IF REST$="y" THEN REST$="Y"
5153 IF REST$="n" THEN REST$="N"
5154 PRINT REST$
5155 IF REST$="Y" THEN 60
5156 IF REST$="N" THEN 100 ELSE 5150
5200 IF A% < > 1 AND A% < =9 THEN 5270 ELSE 5300
5270 IF NOTE=0 THEN 5300
5271 PRINT "WOULD YOU LIKE A LISTING OF COMMONLY OCCURING VEHICLES";
5272 PRINT " INCLUDED IN"
5274 PRINT "THAT CLASS ? (Y or N) ";
5276 INFO$="" :INFO$=INKEY$ :IF INFO$="" THEN 5276
5280 IF INFO$="y" THEN INFO$="Y"
5282 IF INFO$="n" THEN INFO$="N"
5284 PRINT INFO$
5286 IF INFO$="Y" THEN 7000
5288 IF INFO$="N" THEN 5300 ELSE 5200
5300 PRINT "PRESS [C] TO CONTINUE, [M] TO CHANGE MODE OR OPTION, [T] TO";
5301 PRINT " SEE TOTALS,"
5302 PRINT " [R] TO RESET TOTALS TO ZERO, OR [Q] TO QUIT. ";
5303 Y$="" :Y$=INKEY$ :IF Y$="" THEN 5303
5304 IF Y$="c" THEN Y$="C"
5305 IF Y$="m" THEN Y$="M"
5306 IF Y$="t" THEN Y$="T"
5307 IF Y$="r" THEN Y$="R"

```

```

5308 IF Y$="q" THEN Y$="Q"
5309 PRINT Y$
5310 IF Y$="T" THEN 6000
5311 IF Y$="Q" THEN END
5312 IF Y$="R" THEN 60
5313 IF Y$="C" THEN 5314 ELSE 5320
5314 CLS :COLOR 10,1
5315 IF O$="W" THEN PRINT "                               LENGTH-BASED INTERACTIVE MODE"
5316 IF O$="T" THEN PRINT "                               TIME-BASED INTERACTIVE MODE"
5317 COLOR 15,1 :PRINT :PRINT :PRINT :PRINT
5318 IF O$="W" THEN 820
5319 IF O$="T" THEN 530
5320 IF Y$="M" THEN 5325 ELSE 5300
5325 PRINT "PRESS [A] FOR AUTOMATIC MODE OR [I] FOR INTERACTIVE MODE. ";
5330 M$="" :M$=INKEY$ :IF M$="" THEN 5330
5331 IF M$="a" THEN M$="A"
5332 IF M$="i" THEN M$="I"
5333 PRINT M$
5334 IF M$="I" OR M$="A" THEN 5338 ELSE 5325
5338 IF SUM=0 THEN 5339 ELSE 5340
5339 REST$="N" :GOTO 5350
5340 PRINT "RESET TOTALS TO ZERO ? (Y or N) ";
5341 REST$="" :REST$=INKEY$ :IF REST$="" THEN 5341
5342 IF REST$="y" THEN REST$="Y"
5343 IF REST$="n" THEN REST$="N"
5344 PRINT REST$
5345 IF REST$="Y" OR REST$="N" THEN 5350 ELSE 5340
5350 IF M$="A" AND REST$="N" THEN 1207
5351 IF M$="A" AND REST$="Y" THEN 1200
5352 IF M$="I" AND REST$="N" THEN 100
5353 IF M$="I" AND REST$="Y" THEN 60
6000 IF SUM=0 THEN 6005 ELSE 6010
6005 COLOR 12,1 :PRINT " ALL TOTALS ARE PRESENTLY ZERO"
6006 COLOR 15,1
6008 IF M$="A" THEN 5120 ELSE 5300
6010 CLS :COLOR 10,1 :PRINT
6012 PRINT "                               VEHICLE TOTALS BY TYPE AND CLASS"
6014 COLOR 14,1 :PRINT
6016 LCOUNT=3:BCOUNT=0
6020 IF CYC>0 THEN LCOUNT=LCOUNT+2
6022 IF C24>0 THEN LCOUNT=LCOUNT+1
6024 IF C34>0 THEN LCOUNT=LCOUNT+1
6030 IF CYC>0 THEN 6032 ELSE 6060
6032 PRINT " MOTORCYCLES =";CYC;
6034 IF NCYC>0 THEN 6036 ELSE 6042
6036 PRINT " (V Avg. =";
6038 PRINT USING "##.#";VCYC/NCYC;
6039 IF NCYC=1 THEN PRINT " mph. based on 1 known speed)"
6040 IF NCYC>1 THEN PRINT " mph. based on";NCYC;"known speeds)"
6041 GOTO 6044
6042 IF CYC=1 THEN PRINT " (Speed Unknown)"
6043 IF CYC>1 THEN PRINT " (Speeds Unknown)"
6044 COLOR 15,1
6046 IF C24>0 THEN PRINT " ",C24;" Motorcycle";
6048 IF C34>0 THEN PRINT " Only" ELSE PRINT " "
6050 IF C34>0 THEN PRINT " ",C34;" With Trailer"

```

```

6052 COLOR 14,1 :PRINT
6060 IF CAR>0 THEN LCOUNT=LCOUNT+2
6062 IF C21>0 THEN LCOUNT=LCOUNT+1
6064 IF C22>0 THEN LCOUNT=LCOUNT+1
6066 IF C33>0 THEN LCOUNT=LCOUNT+1
6068 IF C44>0 THEN LCOUNT=LCOUNT+1
6070 IF CAR>0 THEN 6072 ELSE 6118
6072 PRINT " PASSENGER CARS =";CAR;
6074 IF NCAR>0 THEN 6076 ELSE 6082
6076 PRINT " (V Avg. =";
6078 PRINT USING "###.#";VCAR/NCAR;
6079 IF NCAR=1 THEN PRINT " mph. based on 1 known speed)"
6080 IF NCAR>1 THEN PRINT " mph. based on";NCAR;"known speeds)"
6081 GOTO 6084
6082 IF CAR=1 THEN PRINT " (Speed Unknown)"
6083 IF CAR>1 THEN PRINT " (Speeds Unknown)"
6084 COLOR 15,1
6086 IF C21>0 THEN PRINT " ",C21;" Small or Midsize Car"
6088 IF C22>0 THEN PRINT " ",C22;" Large Car"
6090 IF C33>0 THEN PRINT " ",C33;" Car with One-Axle Trailer"
6092 IF C44>0 THEN PRINT " ",C44;" Car with Two-Axle Trailer"
6094 COLOR 14,1 :PRINT
6118 BCOUNT=LCOUNT
6120 IF SUT>0 THEN LCOUNT=LCOUNT+2
6122 IF C23>0 THEN LCOUNT=LCOUNT+1
6124 IF C31>0 THEN LCOUNT=LCOUNT+1
6126 IF C43>0 THEN LCOUNT=LCOUNT+1
6128 IF C36>0 THEN LCOUNT=LCOUNT+1
6130 IF C45>0 THEN LCOUNT=LCOUNT+1
6132 IF C46>0 THEN LCOUNT=LCOUNT+1
6134 IF C53>0 THEN LCOUNT=LCOUNT+1
6136 IF C54>0 THEN LCOUNT=LCOUNT+1
6138 IF C63>0 THEN LCOUNT=LCOUNT+1
6140 IF LCOUNT>=18 THEN 6142 ELSE 6150
6142 PRINT "                Press Any Key To Continue Totals"
6144 E$="" :E$=INKEY$ :IF E$="" THEN 6144
6146 CLS:PRINT:COLOR 10,1
6147 PRINT "                VEHICLE TOTALS (Con'd)"
6148 COLOR 14,1:PRINT:LCOUNT=LCOUNT-BCOUNT+3
6150 IF SUT>0 THEN 6152 ELSE 6220
6152 PRINT " SINGLE-UNIT TRUCKS =";SUT;
6154 IF NSUT>0 THEN 6156 ELSE 6162
6156 PRINT " (V Avg. =";
6158 PRINT USING "###.#";VSUT/NSUT;
6159 IF NSUT=1 THEN PRINT " mph. based on 1 known speed)"
6160 IF NSUT>1 THEN PRINT " mph. based on";NSUT;"known speeds)"
6161 GOTO 6164
6162 IF SUT=1 THEN PRINT " (Speed Unknown)"
6163 IF SUT>1 THEN PRINT " (Speeds Unknown)"
6164 COLOR 15,1
6166 IF C23>0 THEN PRINT " ",C23;" 2-Axle SU Truck"
6168 IF C31>0 THEN PRINT " ",C31;" 3-Axle SU Truck"
6170 IF C43>0 THEN PRINT " ",C43;" 4-Axle SU Truck"
6172 IF C36>0 THEN PRINT " ",C36;" 2-Axle SU Truck with One-Axle Trailer"
6174 IF C45>0 THEN PRINT " ",C45;" 2-Axle SU Truck with Two-Axle Trailer"
6176 IF C46>0 THEN PRINT " ",C46;" 3-Axle SU Truck with One-Axle Trailer"

```

```

6178 IF C53 > 0 THEN PRINT " ",C53;" 3-Axle SU Truck with Two-Axle Trailer"
6180 IF C54 > 0 THEN PRINT " ",C54;" 4-Axle SU Truck with One-Axle Trailer"
6182 IF C63 > 0 THEN PRINT " ",C63;" 4-Axle SU Truck with Two-Axle Trailer"
6184 COLOR 14,1 :PRINT
6220 BCOUNT=LCOUNT
6222 IF BUS > 0 THEN LCOUNT=LCOUNT+2
6224 IF C25 > 0 THEN LCOUNT=LCOUNT+1
6226 IF C35 > 0 THEN LCOUNT=LCOUNT+1
6228 IF LCOUNT > = 18 THEN 6230 ELSE 6250
6230 PRINT "          Press Any Key To Continue Totals"
6232 E$="" :E$=INKEY$ :IF E$="" THEN 6232
6234 CLS:PRINT:COLOR 10,1
6235 PRINT "          VEHICLE TOTALS (Con'd)"
6236 COLOR 14,1 :PRINT:LCOUNT=LCOUNT-BCOUNT+3
6250 IF BUS > 0 THEN 6252 ELSE 6300
6252 PRINT " BUSES =";BUS;
6254 IF NBUS > 0 THEN 6256 ELSE 6262
6256 PRINT " (V Avg. =";
6258 PRINT USING "##.#";VBUS/NBUS;
6259 IF NBUS=1 THEN PRINT " mph. based on 1 known speed)"
6260 IF NBUS > 1 THEN PRINT " mph. based on";NBUS;"known speeds)"
6261 GOTO 6264
6262 IF BUS=1 THEN PRINT " (Speed Unknown)"
6263 IF BUS > 1 THEN PRINT " (Speeds Unknown)"
6264 COLOR 15,1
6266 IF C25 > 0 THEN PRINT " ",C25;" Two-Axle Bus"
6268 IF C35 > 0 THEN PRINT " ",C35;" Three-Axle Bus"
6270 COLOR 14,1 :PRINT
6300 BCOUNT=LCOUNT
6302 IF TRTR > 0 THEN LCOUNT=LCOUNT+2
6304 IF C32 > 0 THEN LCOUNT=LCOUNT+1
6306 IF C41 > 0 THEN LCOUNT=LCOUNT+1
6308 IF C55 > 0 THEN LCOUNT=LCOUNT+1
6310 IF C42 > 0 THEN LCOUNT=LCOUNT+1
6312 IF C51 > 0 THEN LCOUNT=LCOUNT+1
6314 IF C61 > 0 THEN LCOUNT=LCOUNT+1
6316 IF C64 > 0 THEN LCOUNT=LCOUNT+1
6317 IF C73 > 0 THEN LCOUNT=LCOUNT+1
6318 IF C52 > 0 THEN LCOUNT=LCOUNT+1
6320 IF C62 > 0 THEN LCOUNT=LCOUNT+1
6322 IF C91 > 0 THEN LCOUNT=LCOUNT+1
6324 IF C71 > 0 THEN LCOUNT=LCOUNT+1
6326 IF C72 > 0 THEN LCOUNT=LCOUNT+1
6328 IF C81 > 0 THEN LCOUNT=LCOUNT+1
6330 IF LCOUNT > = 18 THEN 6332 ELSE 6350
6332 PRINT "          Press Any Key To Continue Totals"
6334 E$="" :E$=INKEY$ :IF E$="" THEN 6334
6336 CLS:PRINT:COLOR 10,1
6337 PRINT "          VEHICLE TOTALS (Con'd)"
6338 COLOR 14,1:PRINT:LCOUNT=LCOUNT-BCOUNT+3
6350 IF TRTR > 0 THEN 6352 ELSE 6400
6352 PRINT " TRACTOR-TRAILERS =";TRTR;
6354 IF NTRTR > 0 THEN 6356 ELSE 6362
6356 PRINT " (V Avg. =";
6358 PRINT USING "##.#";VTRTR/NTRTR;
6359 IF NTRTR=1 THEN PRINT " mph. based on 1 known speed)"

```

```

6360 IF NTRTR > 1 THEN PRINT " mph. based on";NTRTR;"known speeds)"
6361 GOTO 6364
6362 IF TRTR=1 THEN PRINT " (Speed Unknown)"
6363 IF TRTR > 1 THEN PRINT " (Speeds Unknown)"
6364 COLOR 15,1
6366 IF C32 > 0 THEN PRINT " ",C32;" 2-Axle Tractor with 1-Axle Semitrailer"
6368 IF C41 > 0 THEN PRINT " ",C41;" 2-Axle Tractor with 2-Axle Semitrailer"
6370 IF C55 > 0 THEN PRINT " ",C55;" 2-Axle Tractor with 3-Axle Semitrailer"
6372 IF C42 > 0 THEN PRINT " ",C42;" 3-Axle Tractor with 1-Axle Semitrailer"
6374 IF C51 > 0 THEN PRINT " ",C51;" 3-Axle Tractor with 2-Axle Semitrailer"
6376 IF C61 > 0 THEN PRINT " ",C61;" 3-Axle Tractor with 3-Axle Semitrailer"
6378 IF C64 > 0 THEN PRINT " ",C64;" 4-Axle Tractor with 2-Axle Semitrailer"
6379 IF C73 > 0 THEN PRINT " ",C73;" 4-Axle Tractor with 3-Axle Semitrailer"
6380 IF C52 > 0 THEN PRINT " ",C52;" 2-Axle Tractor with 2 Short Trailers"
6382 IF C62 > 0 THEN PRINT " ",C62;" 3-Axle Tractor with 2 Short Trailers"
6386 IF C71 > 0 THEN PRINT " ",C71;" 3-Axle Tractor with Two Trailers"
6388 IF C72 > 0 THEN PRINT " ",C72;" 2-Axle Tractor with 3 Short Trailers"
6390 IF C81 > 0 THEN PRINT " ",C81;" 3-Axle Tractor with 3 Short Trailers"
6392 IF C91 > 0 THEN PRINT " ",C91;" 3-Axle Tractor with 2 Long Trailers"
6394 COLOR 14,1 :PRINT
6400 BCOUNT = LCOUNT
6402 IF OTHR > 0 THEN LCOUNT = LCOUNT + 2
6404 IF C10 > 0 THEN LCOUNT = LCOUNT + 1
6406 IF C20 > 0 THEN LCOUNT = LCOUNT + 1
6408 IF C30 > 0 THEN LCOUNT = LCOUNT + 1
6410 IF C40 > 0 THEN LCOUNT = LCOUNT + 1
6412 IF C50 > 0 THEN LCOUNT = LCOUNT + 1
6414 IF C60 > 0 THEN LCOUNT = LCOUNT + 1
6416 IF C70 > 0 THEN LCOUNT = LCOUNT + 1
6418 IF C80 > 0 THEN LCOUNT = LCOUNT + 1
6420 IF C90 > 0 THEN LCOUNT = LCOUNT + 1
6422 IF C100 > 0 THEN LCOUNT = LCOUNT + 1
6424 IF LCOUNT > = 18 THEN 6426 ELSE 6450
6426 PRINT "          Press Any Key To Continue Totals"
6428 E$ = "" :E$ = INKEY$ :IF E$ = "" THEN 6428
6430 CLS:PRINT:COLOR 10,1
6431 PRINT "          VEHICLE TOTALS (Con'd)"
6432 COLOR 14,1:PRINT:LCOUNT = LCOUNT - BCOUNT + 3
6450 IF OTHR > 0 THEN 6452 ELSE 6570
6452 PRINT " OTHER VEHICLES =";OTHR;
6454 IF NOTH > 0 THEN 6456 ELSE 6462
6456 PRINT " (V Avg. =";
6458 PRINT USING "##.#";VOTH/NOTH;
6459 IF NOTH = 1 THEN PRINT " mph. based on 1 known speed)"
6460 IF NOTH > 1 THEN PRINT " mph. based on";NOTH;"known speeds)"
6461 GOTO 6464
6462 IF OTHR = 1 THEN PRINT " (Speed Unknown)"
6463 IF OTHR > 1 THEN PRINT " (Speeds Unknown)"
6464 COLOR 15,1
6466 IF C10 > 0 THEN PRINT " ",C10;" Had Only One Axle Recorded"
6468 IF C20 > 0 THEN PRINT " ",C20;" Unknown 2-Axle Vehicle"
6470 IF C30 > 0 THEN PRINT " ",C30;" Unknown 3-Axle Vehicle"
6472 IF C40 > 0 THEN PRINT " ",C40;" Unknown 4-Axle Vehicle"
6474 IF C50 > 0 THEN PRINT " ",C50;" Unknown 5-Axle Vehicle"
6476 IF C60 > 0 THEN PRINT " ",C60;" Unknown 6-Axle Vehicle"
6478 IF C70 > 0 THEN PRINT " ",C70;" Unknown 7-Axle Vehicle"

```

```

6480 IF C80>0 THEN PRINT " ",C80;" Unknown 8-Axle Vehicle"
6482 IF C90>0 THEN PRINT " ",C90;" Unknown 9-Axle Vehicle"
6484 IF C100>0 THEN PRINT " ",C100;" Unknown 10+ Axle Vehicle"
6486 PRINT
6570 COLOR 15,1
6572 PRINT "WOULD YOU LIKE A PRINTOUT OF THOSE TOTALS ? (Y or N) ";
6573 PTOT$="" :PTOT$=INKEY$ :IF PTOT$="" THEN 6573
6574 IF PTOT$="y" THEN PTOT$="Y"
6575 IF PTOT$="n" THEN PTOT$="N"
6576 PRINT PTOT$
6577 IF PTOT$="Y" THEN 6590
6578 IF PTOT$="N" THEN 6580 ELSE 6572
6580 IF M$="A" THEN 5120 ELSE 5300
6590 PRINT "PRESS ANY KEY WHEN PRINTER READY"
6591 DUM$="" :DUM$=INKEY$ :IF DUM$="" THEN 6591
6600 IF CYC>0 THEN 6602 ELSE 6640
6602 PRINT #1," MOTORCYCLES =";CYC;
6604 IF NCYC>0 THEN 6606 ELSE 6612
6606 PRINT #1," (V Avg. =";
6608 PRINT #1,USING "##.#";VCYC/NCYC;
6609 IF NCYC=1 THEN PRINT #1," mph. based on 1 known speed)"
6610 IF NCYC>1 THEN PRINT #1," mph. based on";NCYC;"known speeds)"
6611 GOTO 6614
6612 IF CYC=1 THEN PRINT #1," (Speed Unknown)"
6613 IF CYC>1 THEN PRINT #1," (Speeds Unknown)"
6614 IF C24>0 THEN PRINT #1," ",C24;" Motorcycle";
6616 IF C34>0 THEN PRINT #1," Only" ELSE PRINT #1," "
6618 IF C34>0 THEN PRINT #1," ",C34;" With Trailer"
6620 PRINT #1," "
6640 IF CAR>0 THEN 6642 ELSE 6680
6642 PRINT #1," PASSENGER CARS =";CAR;
6644 IF NCAR>0 THEN 6646 ELSE 6652
6646 PRINT #1," (V Avg. =";
6648 PRINT #1,USING "##.#";VCAR/NCAR;
6649 IF NCAR=1 THEN PRINT #1," mph. based on 1 known speed)"
6650 IF NCAR>1 THEN PRINT #1," mph. based on";NCAR;"known speeds)"
6651 GOTO 6654
6652 IF CAR=1 THEN PRINT #1," (Speed Unknown)"
6653 IF CAR>1 THEN PRINT #1," (Speeds Unknown)"
6654 IF C21>0 THEN PRINT #1," ",C21;" Small or Midsize Car"
6656 IF C22>0 THEN PRINT #1," ",C22;" Large Car"
6658 IF C33>0 THEN PRINT #1," ",C33;" Car with One-Axle Trailer"
6660 IF C44>0 THEN PRINT #1," ",C44;" Car with Two-Axle Trailer"
6662 PRINT #1," "
6680 IF SUT>0 THEN 6682 ELSE 6730
6682 PRINT #1," SINGLE-UNIT TRUCKS =";SUT;
6684 IF NSUT>0 THEN 6686 ELSE 6692
6686 PRINT #1," (V Avg. =";
6688 PRINT #1,USING "##.#";VSUT/NSUT;
6689 IF NSUT=1 THEN PRINT #1," mph. based on 1 known speed)"
6690 IF NSUT>1 THEN PRINT #1," mph. based on";NSUT;"known speeds)"
6691 GOTO 6694
6692 IF SUT=1 THEN PRINT #1," (Speed Unknown)"
6693 IF SUT>1 THEN PRINT #1," (Speeds Unknown)"
6694 IF C23>0 THEN PRINT #1," ",C23;" Two-Axle SU Truck"
6696 IF C31>0 THEN PRINT #1," ",C31;" Three3-Axle SU Truck"

```

```

6698 IF C43 > 0 THEN PRINT #1, " ", C43, " 4-Axle SU Truck"
6700 IF C36 > 0 THEN PRINT #1, " ", C36, " 2-Axle SU Truck with One-Axle Trailer"
6702 IF C45 > 0 THEN PRINT #1, " ", C45, " 2-Axle SU Truck with Two-Axle Trailer"
6704 IF C46 > 0 THEN PRINT #1, " ", C46, " 3-Axle SU Truck with One-Axle Trailer"
6706 IF C53 > 0 THEN PRINT #1, " ", C53, " 3-Axle SU Truck with Two-Axle Trailer"
6708 IF C54 > 0 THEN PRINT #1, " ", C54, " 4-Axle SU Truck with One-Axle Trailer"
6710 IF C63 > 0 THEN PRINT #1, " ", C63, " 4-Axle SU Truck with Two-Axle Trailer"
6712 PRINT #1, " "
6730 IF BUS > 0 THEN 6732 ELSE 6760
6732 PRINT #1, " BUSES = "; BUS;
6734 IF NBUS > 0 THEN 6736 ELSE 6742
6736 PRINT #1, " (V Avg. = ";
6738 PRINT #1, USING "###.": VBUS/NBUS;
6739 IF NBUS = 1 THEN PRINT #1, " mph. based on 1 known speed)"
6740 IF NBUS > 1 THEN PRINT #1, " mph. based on "; NBUS, " known speeds)"
6741 GOTO 6744
6742 IF BUS = 1 THEN PRINT #1, " (Speed Unknown)"
6743 IF BUS > 1 THEN PRINT #1, " (Speeds Unknown)"
6744 IF C25 > 0 THEN PRINT #1, " ", C25, " Two-Axle Bus"
6746 IF C35 > 0 THEN PRINT #1, " ", C35, " Three-Axle Bus"
6748 PRINT #1, " "
6760 IF TRTR > 0 THEN 6762 ELSE 6800
6762 PRINT #1, " TRACTOR-TRAILERS = "; TRTR;
6764 IF NTRTR > 0 THEN 6766 ELSE 6772
6766 PRINT #1, " (V Avg. = ";
6768 PRINT #1, USING "###.": VTRTR/NTRTR;
6769 IF NTRTR = 1 THEN PRINT #1, " mph. based on 1 known speed)"
6770 IF NTRTR > 1 THEN PRINT #1, " mph. based on "; NTRTR, " known speeds)"
6771 GOTO 6774
6772 IF TRTR = 1 THEN PRINT #1, " (Speed Unknown)"
6773 IF TRTR > 1 THEN PRINT #1, " (Speeds Unknown)"
6774 IF C32 > 0 THEN PRINT #1, " ", C32, " 2-Axle Tractor with 1-Axle Semitrailer"
6776 IF C41 > 0 THEN PRINT #1, " ", C41, " 2-Axle Tractor with 2-Axle Semitrailer"
6778 IF C55 > 0 THEN PRINT #1, " ", C55, " 2-Axle Tractor with 3-Axle Semitrailer"
6780 IF C42 > 0 THEN PRINT #1, " ", C42, " 3-Axle Tractor with 1-Axle Semitrailer"
6782 IF C51 > 0 THEN PRINT #1, " ", C51, " 3-Axle Tractor with 2-Axle Semitrailer"
6784 IF C61 > 0 THEN PRINT #1, " ", C61, " 3-Axle Tractor with 3-Axle Semitrailer"
6786 IF C64 > 0 THEN PRINT #1, " ", C64, " 4-Axle Tractor with 2-Axle Semitrailer"
6787 IF C73 > 0 THEN PRINT #1, " ", C73, " 4-Axle Tractor with 3-Axle Semitrailer"
6788 IF C52 > 0 THEN PRINT #1, " ", C52, " 2-Axle Tractor with 2 Short Trailers"
6790 IF C62 > 0 THEN PRINT #1, " ", C62, " 3-Axle Tractor with 2 Short Trailers"
6792 IF C71 > 0 THEN PRINT #1, " ", C71, " 3-Axle Tractor with Two Trailers"
6794 IF C72 > 0 THEN PRINT #1, " ", C72, " 2-Axle Tractor with 3 Short Trailers"
6796 IF C81 > 0 THEN PRINT #1, " ", C81, " 3-Axle Tractor with 3 Short Trailers"
6798 IF C91 > 0 THEN PRINT #1, " ", C91, " 3-Axle Tractor with 2 Long Trailers"
6799 PRINT #1, " "
6800 IF OTHR > 0 THEN 6802 ELSE 6900
6802 PRINT #1, " OTHER VEHICLES = "; OTHR;
6804 IF NOTH > 0 THEN 6806 ELSE 6812
6806 PRINT #1, " (V Avg. = ";
6808 PRINT #1, USING "###.": VOTH/NOTH;
6809 IF NOTH = 1 THEN PRINT #1, " mph. based on 1 known speed)"
6810 IF NOTH > 1 THEN PRINT #1, " mph. based on "; NOTH, " known speeds)"
6811 GOTO 6814
6812 IF OTHR = 1 THEN PRINT #1, " (Speed Unknown)"
6813 IF OTHR > 1 THEN PRINT #1, " (Speeds Unknown)"

```

```

6814 IF C10>0 THEN PRINT #1," ",C10;" Had Only One Axle Recorded"
6816 IF C20>0 THEN PRINT #1," ",C20;" Unknown 2-Axle Vehicle"
6818 IF C30>0 THEN PRINT #1," ",C30;" Unknown 3-Axle Vehicle"
6820 IF C40>0 THEN PRINT #1," ",C40;" Unknown 4-Axle Vehicle"
6822 IF C50>0 THEN PRINT #1," ",C50;" Unknown 5-Axle Vehicle"
6824 IF C60>0 THEN PRINT #1," ",C60;" Unknown 6-Axle Vehicle"
6826 IF C70>0 THEN PRINT #1," ",C70;" Unknown 7-Axle Vehicle"
6828 IF C80>0 THEN PRINT #1," ",C80;" Unknown 8-Axle Vehicle"
6830 IF C90>0 THEN PRINT #1," ",C90;" Unknown 9-Axle Vehicle"
6832 IF C100>0 THEN PRINT #1," ",C100;" Unknown 10+ Axle Vehicle"
6834 PRINT #1," "
6900 PRINT "WOULD YOU LIKE ANOTHER PRINTOUT OF THOSE TOTALS ? (Y or N) ";
6901 PTOT$="" :PTOT$=INKEY$:IF PTOT$="" THEN 6901
6902 IF PTOT$="y" THEN PTOT$="Y"
6903 IF PTOT$="n" THEN PTOT$="N"
6904 PRINT PTOT$
6905 GOTO 6577
7000 COLOR 10,1 :PRINT :PRINT :PRINT
7002 PRINT "          VEHICLES OF THAT CLASS ( CLASS "; G;)"
7004 PRINT :PRINT "Most Common Vehicle: ";
7008 COLOR 14,1 :PRINT MCV$
7010 PRINT :COLOR 10,1 :PRINT "Other Vehicles:  ";
7012 COLOR 14.1 :PRINT OCV$
7014 PRINT :PRINT
7016 COLOR 10,1 :PRINT "VEHICLES OF OTHER CLASSES THAT MAY BE
INCORRECTLY";
7018 PRINT " CLASSIFIED INTO THIS CLASS:"
7020 COLOR 14,1 :PRINT "          ";WVC$
7022 IF NOTE=2 THEN PRINT "          ";WVC2$
7023 IF NOTE=1 THEN PRINT
7100 COLOR 15,1 :PRINT :PRINT :PRINT : GOTO 5300

```

**The vita has been removed from
the scanned document**