



KITCHENS: Development of the Plan

Prepared by: Robert J. Thee, Extension Specialist, Housing, Virginia Tech.

DETERMINE THE LOCATION OF THE KITCHEN AND THE ACTUAL SPACE NEEDED

Locate the kitchen to avoid general traffic through its work area and to be convenient to the dining and living area(s) of the house.

In addition, the location of the kitchen depends upon:

- convenience to yard or outside work area: if important, does a window look out into the yard or work area?
- convenience for unloading of groceries and disposal of garbage and trash,
- accessibility to the front or back door.

Kitchen areas which become part of a larger living space need a ventilating system to remove odors and quietly operating appliances installed to reduce the noise level (example: rubber mountings).

Measure the kitchen space and make a scale drawing of the room. Blueprints will give room dimensions, but more exact measurements, taken after the interior walls are in place, are needed for a good cabinet fit. Many kitchen professionals will also take these measurements for you.

1. Measure the length and width of the rooms. Measure the full distance from corner to corner and the distance of the subsections within. (As a double check on your measurements, compare the overall measurement with the sum of the subsections).

2. Measure walls with windows in this manner:

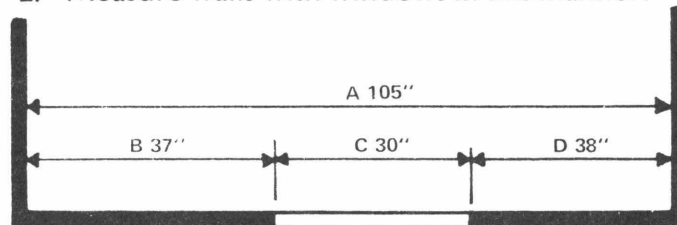

A from wall to wall

B from corner to outside trim of window

C outside window trim to outside window trim

D outside trim of window to corner

3. Measure all corners for squareness. To do this, find points A and B as shown below. The distance between the points should equal 5 feet. NOTE: If corners are not square, some adjustments will need to be made during installation or problems requiring adjustment will arise.

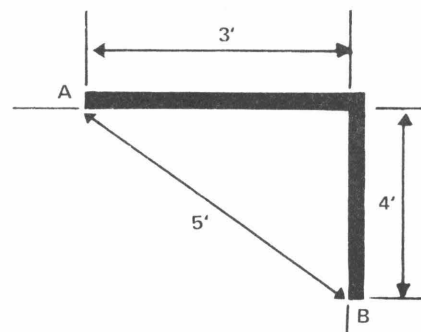

4. In addition, other measurements needed are:

- the distance from the top of the window trim to ceiling and from the bottom of

Based on: "Kitchen Planning, New and Remodeled." Special Report 92, by Wanda Olson and Delores Ginthner, Agricultural Extension Service, University of Minnesota.

Virginia Cooperative Extension Service programs, activities, and employment opportunities are available to all people regardless of race, color, religion, sex, age, national origin, handicap, or political affiliation. An equal opportunity/affirmative action employer.

Issued in furtherance of Cooperative Extension work, Acts of May 8 and June 30, 1914, and September 30, 1977, in cooperation with the U.S. Department of Agriculture. Mitchell R. Geasler, Director, Virginia Cooperative Extension Service, and Vice Provost for Extension, Virginia Polytechnic Institute and State University, Blacksburg, Virginia 24061; M. C. Harding, Sr., Administrator, 1890 Extension Program, Virginia State University, Petersburg, Virginia 23803.

LD
5655
A762
No. 356-144
VPI
Spec

- the window trim to the floor, and the dimension of the soffit, if there is one, and the distance from the soffit to the floor (measure at several locations). The soffit is the enclosed area below the ceiling and above the wall cabinets.

- Make a scale drawing of the room, 1/2 inch to 1 foot. Use graph paper ruled at four squares to the inch. Draw in all windows and doors; note the direction of the door swing and the room or area into which the door opens. Draw in any chimneys, radiators, air ducts in walls, location of water supply, drainage pipes and vents, gas pipes, and electrical outlets. Indicate wall thickness and whether interior walls are bearing or non-bearing walls.

TEST POSSIBLE KITCHEN SHAPES

The actual arrangement depends greatly on the room dimensions and the door and window placement. Changing the location of doors or windows may be necessary for a more efficient arrangement. Kitchens designed to be used by more than one person need more space for movement and efficient use of equipment. The following diagrams illustrate the approximate space needs for 8 feet of base and wall cabinets and refrigerator, range, and dishwasher arranged in the "L", "U", corridor, and island shapes.

"U" SHAPE

Allows short distance between work centers and eliminates traffic through the work area. Without special provisions, the two corner storage areas may be difficult to use effectively.

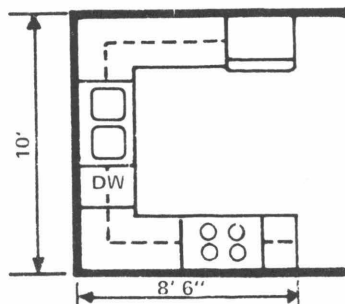

"L" SHAPE

A convenient arrangement if more than one person will use the kitchen at the same time. It has one corner storage area which may be difficult to use.

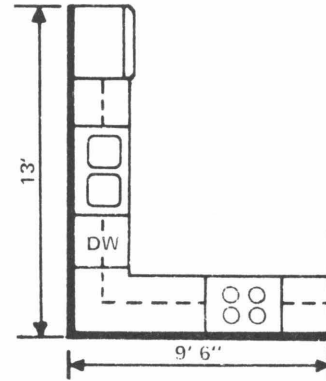

CORRIDOR SHAPE

This arrangement can be used where there is a minimum amount of space available; it is best if the corridor will not be used as a traffic thoroughfare. There are no inaccessible corners.

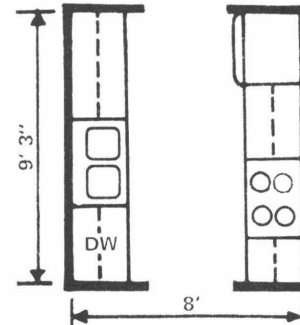

ISLAND OR BROKEN "U" SHAPE

This arrangement requires more space than the others in order to have room to walk around the island. The minimum dimensions for the island are 2'-6" by 3'. A larger island is needed if it includes an appliance.

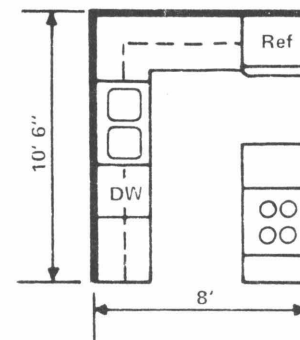

DINING SPACE AND EATING COUNTERS

For a small dining space within the kitchen, at least 8'-8" of clear space is needed for a 36" x 48" table and four chairs as shown at the right. Eating counters are handy, but usually do not allow diners to face each other.

Space for table and chairs:

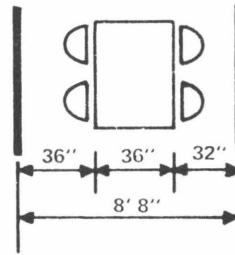

32" is needed to rise from the table,
36" is needed to ease past a seated person.

Basic dimensions for eating counters:

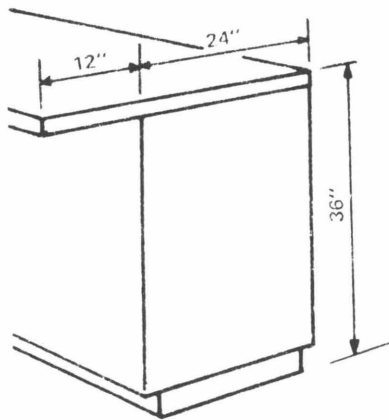

Level counter
stool seating

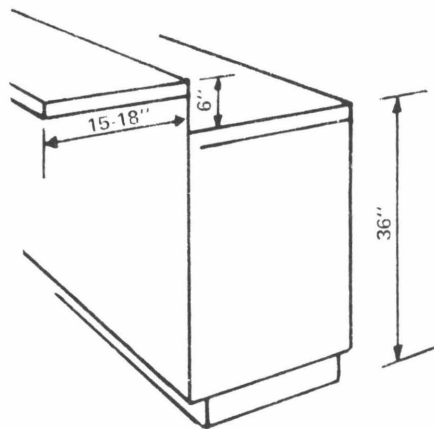

Raised counter
stool seating

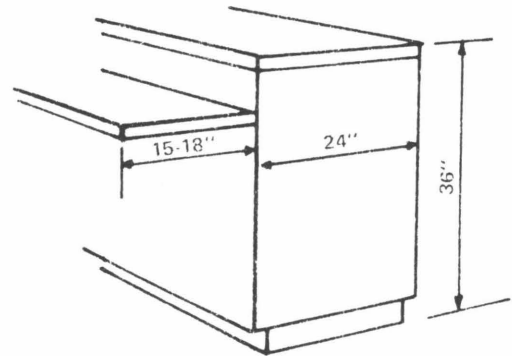

Lowered counter
chair seating

DETERMINE WORK CENTER ARRANGEMENT

The kitchen is the most intensively used space in the home. Efficient kitchens need well-developed work centers. These centers include sink and cleanup, mix and preparation, range and cooking, and refrigerator and storage: serving is often combined with the range.

The microwave oven may be a separate center or replace the range in the range and cooking center. Evaluate the intended use of the microwave before choosing the location for this appliance. If it is used primarily by several persons preparing snack foods or individual items, consider locating it out of the central work area. Many foods heated in the microwave

come from the refrigerator/freezer and need little preparation before going into the microwave. However, if the microwave oven will be replacing many of the uses of the range top in meal preparation, it may replace the range in the central work area.

Arrange the work centers to reduce the amount of walking in the kitchen and to allow work to flow easily from one center to another. The work areas should not be split by traffic (see illustrations on page 4). Normally the largest number of trips during meal preparation occurs between the sink and the range top; many trips occur between the mix center and the sink and between the mix center and the refrigerator.

Traffic Problem:

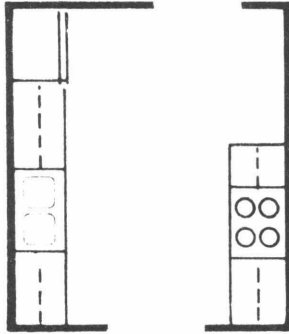

Alternative Solutions:

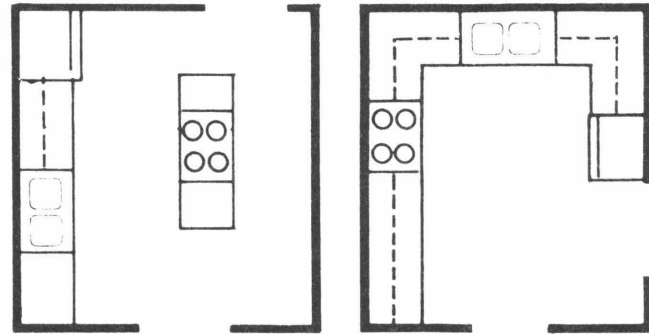

Rearrange Cabinets

Change Door

Do not install the range next to the refrigerator; it will make the operation of the refrigerator more costly and reduce its lifetime.

Measure the distance between the sink, range and refrigerator; this space is called the work triangle and should be between 12 and 22 feet in perimeter. The distance between the sink and refrigerator should be from 4 to 7 feet, and between the range and refrigerator from 4 to 9 feet.

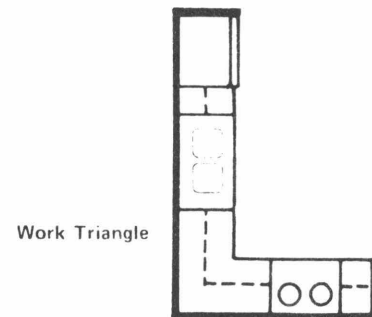

SOLVING DESIGN PROBLEMS

For very small kitchens:

- Use smaller sized appliances. Appliances are available in widths as narrow as 18 inches for dishwashers, 18 to 20 inches for ranges, and 24 inches for refrigerators. Small-sized appliances are available separately or as a part of a combination unit frequently used in efficiency apartments or in businesses. A 48-inch unit may contain a range and a sink with a dishwasher below. An 84-inch unit may contain a range, sink, dishwasher, and a 30-inch undercounter refrigerator. A portable oven takes less space than a built-in oven.
- Use fewer major appliances—do not separate range top and oven.
- Use specialized storage, such as a full storage cabinet or pantry unit or build shallow storage in walls between studs.
- Use a fold-down table or a table that pulls out of the base cabinet for eating.
- Relocate or eliminate doors or windows; remove a dividing wall and make into one room.

- Use light colors, no pattern or small patterns, minimize rough textures and contrast.
- Use enough light to eliminate shadow.

For kitchens with minimal wall space because of many doors and window sills too close to the floor for standard base cabinets:

- If the room is large enough, plan the kitchen workspace within a portion of the area.
- If the windows are spaced appropriately, plan a corridor kitchen.
- If wall cabinet storage is minimal, add a full storage cabinet or pantry unit elsewhere in the kitchen.

CHECK PLANS FOR WORK, STORAGE, AND CLEARANCE SPACE

The recommended amounts of work and storage space are listed in Chart 1. Storage space should be arranged so that frequently used items are stored at the point of first use and are easily accessible. For example, the mixing

center should handle food staples used there, mixing bowls and spoons, measuring equipment, and appliances such as the mixer.

Many small appliances need storage space but only require counter space for short time periods. A portable oven, for example, requires counter space for longer periods of time than a toaster.

Adequate clearance space is needed so that cabinets and appliances can be opened and are

accessible for work. Crowded plans create unsafe conditions.

Clearance space requirements indicated below are industry recommendations. HUD (U.S. Department of Housing and Urban Development) minimum standards are given in parentheses. HUD minimums are for new construction of one and two family dwellings and must be met whenever the loan on the property will be insured through a HUD-sponsored mortgage insurance program.

CABINET DIMENSIONS

Wall cabinets: Depth 12-13 inches
 Height 12-33 inches
 Width 9-60 inches

Clearance between upper cabinet and counter 15-18 inches; over sink 24-30 inches; over range 27-30 inches (24 inches if cabinet is fire protected)

Base cabinets: Depth 24 inches
 Height normally 36 inches with toespace of 4 inches
 Width 9-60 inches (available in 3-inch modules)

Standard counter height 36 inches; counter should be 3 inches below elbow for most tasks, 6 inches below elbow for rolling out or kneading tasks

Sit down work surface: 30 inches from floor

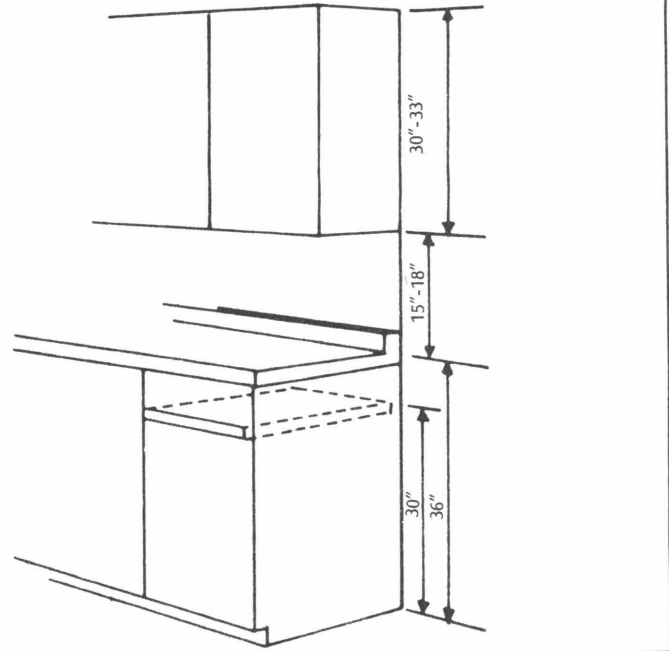

Kitchen professionals should make sure that your plan meets the following space requirements:

1. Doors should not be placed closer than 30 inches from the corner if cabinets are to be extended to the corner. Windows should not be placed closer than 12¾ inches from the corner if wall cabinets are to be extended to the corner. See Figure 1.

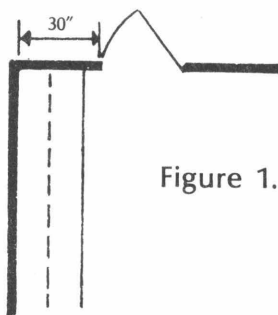

Figure 1.

2. Clearance space between base cabinet fronts in the food preparation area is 48-60 inches (40). If two people are working, 48 inches is the minimum. Clearance space between the face of one cabinet and the side of another is 38 inches (30). See Figure 2.

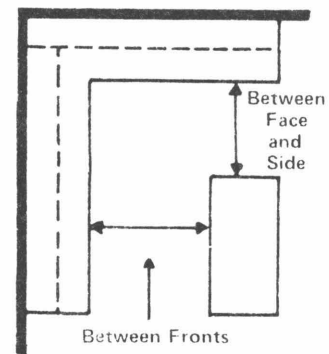
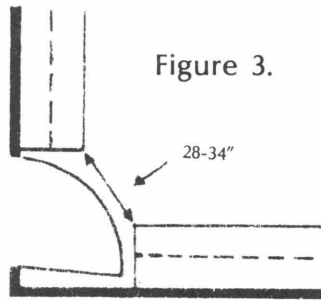
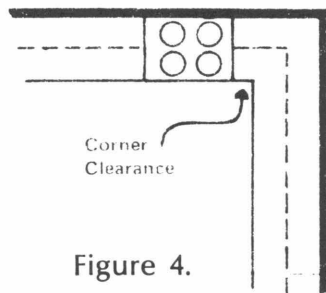

Figure 2.

3. Corner to corner clearance space between appliances or base cabinets at right angles to each other is 34 inches (28). See Figure 3.



4. Corner clearances are (See Figure 4):
 Edge of range and corner cabinets 12 inches (9).
 Edge of refrigerator to corner cabinet 15 inches (15).
 Edge of sink and corner cabinet 9-12 inches.



5. A diagonal cabinet of 20 inches requires 39 inches on either wall. A diagonal cabinet or appliance of 30 inches requires 45 inches on either wall. See Figure 5.

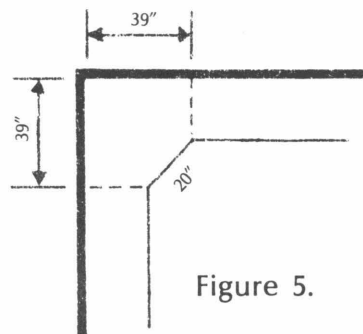

6. 36 inches on each side is needed for a lazy Susan. See Figure 6.

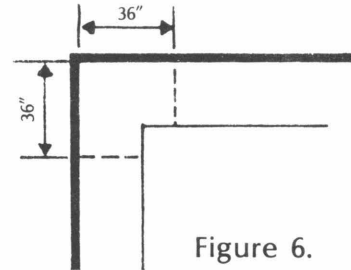

7. Use fillers or extended stiles to insure full operation of cabinet or appliance drawers and doors in the following situations (See Figure 7):

- appliance, such as a dishwasher, is placed too close to a cabinet intersection;
- cabinet is placed too close to a wall that is out of square or has door or window frames that interfere with pull-out drawers and shelves;
- hardware projections.

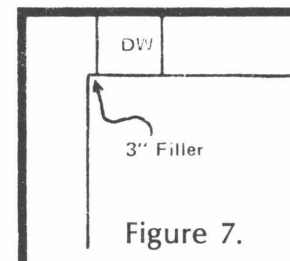

8. A built-in conventional oven should be placed so that the top side of the fully opened door is between 1 and 7 inches below the user's elbow.
9. The microwave oven should be at a height so that the shelf or rack(s) is no higher than the user's shoulder; for most convenient use, the shelf or rack(s) should be between 2 inches below the elbow and 10 inches above the elbow. The microwave may be built into an oven or wall cabinet or be recessed into an interior wall. It needs work space, counter, pull-out tray or drop leaf, near the access side of the door.

10. The depth of the range hood determines the height at which it is located. A hood 17 inches or less in depth should be placed no less than 20 inches above the range top, hoods 18 inches or more in depth should be installed no less than 24 inches above the range top. See Figure 8.

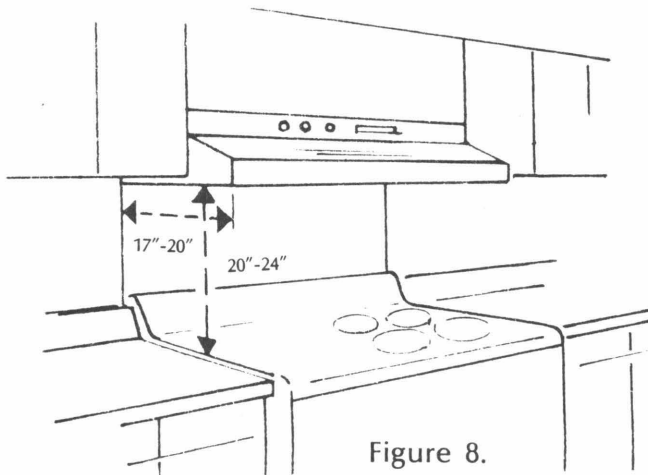

Figure 8.

DEVELOP THE DESIGN

When selecting cabinets choose moldings that are well proportioned in relation to the cabinet doors. The lines and shapes should relate to each other and to the overall cabinet door front. There should be repetition of line, shape, and form to create unity. The hardware should relate to the cabinet door in terms of form and style. Avoid the overly ornate; an excess of grooves can be a grease and dust catcher. A backplate installed behind the door pull will help protect the cabinet finish. Choose door pulls and hardware that are efficient and convenient to use. Door pulls located in the center of the cabinet door for aesthetic reasons reduce the leverage available for opening the door and require the user to reach higher—something which may be difficult for someone with limited movement of the arms.

In all choices, think about the function of the item and how well the form expresses the function. In a kitchen the textures are especially important; all materials should have surfaces that are easily cleaned. It is difficult to clean spills from rough textures on counters, walls, and floors. Storage should be provided so that articles are stored at their point of first use, at a convenient height for the items used most often, and that like items are stored together.

PATTERNS

When selecting wall coverings, or other materials with patterns, look at the design carefully and evaluate the quality of the design. There are many well-designed patterns on the market. The size of the pattern should relate to the size of the space. Generally, in small spaces it is a good idea to select no pattern or only small patterns and to minimize the amount of contrast. Larger spaces can generally handle more contrast and larger, bolder patterns.

ACCESSORIES

Accessories in a kitchen contribute to the character and should be consistent with the overall feeling. These may be functional accessories such as canisters, spices, utensils, wine racks, clocks, pottery, baskets, and other serving pieces. Or they may be purely decorative such as plants, art work, collections, or items related to hobbies and other interests.

COLOR

Choosing the colors for a living space should be done with care and skill. Color dramatically affects the appearance of an area as well as the mood of the users. There is no limitation and no “right” color. In other words, a perfect color for all kitchens does not exist. Pick colors you like that are satisfying to you.

Colors change under natural and artificial lighting conditions and when seen in relation to other colors. Some colors—red, orange, and yellow—appear to be warm and are considered advancing and active colors. The cool colors—blue, green, and violet—appear to recede and feel more relaxing. If the kitchen is on the north side of the house, cool colors will make the room feel even cooler. Remember, increasing the amount of the color increases the impact of that color.

CHART I

Recommended Amounts of Kitchen Storage and Work Space in Inches of Counter Frontage

<i>Kitchen Industry Recommendations</i>			<i>HUD Minimum Standards</i>			
			2 Bedroom	3 Bedroom	4 Bedroom	
Sink Center	Counter surface on one side	24 - 36	Counter surface and base cabinet on each side	20	24	30
	Counter surface on the other side	18 - 30	Space allowed for the sink itself	24	32	32
Range Center*	Counter surface on one side	15 - 24	Counter surface and base cabinet on one side	21	24	30
	Minimum on either side for safety	12 - 12	Space allowed for the range itself	24	30	30
Refrigerator Center	Counter surface at latch side	15 - 18	Counter surface at latch side	15	15	18
			Space allowed for the refrigerator itself	36	36 or 33" if door opens within own width	36
Mixing Center	Counter surface	36 - 42	Base and wall cabinet	36	36	42
Total counter surface frontage		72 - 109				
	Whenever work centers are combined the counter should be equal to the longer of the counter tops being combined plus 12 inches.		When work centers are combined, the counter should be equal to the longer of the counter tops being combined.			
Total Base cabinets		72 - 120	Kitchen storage shelf area**	38 sq. ft.	44 sq. ft.	50 sq. ft.
Wall cabinets		72 - 120	Kitchen storage in drawer area**	8 sq. ft.	10 sq. ft.	12 sq. ft.
	Each inch of frontage in a full height-storage wall at least 20" is equal to 2" of base cabinet, if at least 12" deep it is equal to 2" of wall cabinet.					

*A microwave oven requires counter surface at the latch side of the oven if it is side-hinged. The surface should be large enough to accommodate the utensil plus the cover and be adjacent to the oven or below the oven when the oven is located above counter height. An oven above counter can be built into a wall cabinet, an oven cabinet, or built into an interior wall.

**At least one third of the required shelf area shall be located in base or wall cabinets. At least 60 percent of the required area shall be enclosed by cabinet door. Dishwasher may be counted as 4 sq. ft. of base cabinet storage. Wall cabinets over refrigerator shall not be counted as required shelf area. Shelf area above 74" from the floor shall not be counted as required area. Inside corner cabinet shall be counted as 50 percent of the shelf area, except when revolving shelves are used the actual shelf area may be counted. Drawer area in excess of the required area may be counted as shelf area if drawers are at least 6" in depth.