

Rapid detection of *Escherichia coli* in field based potable water applications

Sathieseelan Thayagan

Submitted to the faculty of the Virginia Polytechnic Institute and State University in
partial fulfillment of the requirements for the degree of

Master of Science

In

Agriculture and Life Sciences

Dr. Laura Strawn (chair)

Dr. Joseph Eifert

Dr. Robert Williams

12th March 2018

Blacksburg, Virginia

Keywords: Qdot, streptavidin, *E.coli* 0157:H7, *Escherichia coli*, fluorescence

Copyright © Sathieseelan Thayagan, 2018

Rapid detection of *Escherichia coli* in field based potable water applications

Sathieseelan Thayagan

ABSTRACT

Foodborne illness stemming from the use of contaminated water in agriculture has resulted in human death and illness and even though water sanitation standards in the United States have improved, there has been a number of foodborne outbreaks associated with drinking water. The United States Environmental Protection Agency (EPA) in the Revised Total Coliform Rule (RTCR), set the maximum contaminant level for *E. coli* in drinking water, whilst the United States Department of Agriculture (USDA) has set tolerance limits for fecal coliforms and/or *E. coli* in water used for livestock consumption and water used to wash food products and food handling equipment. Rapid on-site methodology to obtain *E.coli* 0157:H7 results in minutes, combined with operator ease of use is required. In this paper, we developed a simple antigen florescence based analysis for *E.coli* 0157:H7 that can be used in the field with results obtained in less than 5 minutes and read using a cell phone camera app. No pre-enrichment is required to obtain a level of detection (LOD) of one colony forming unit (CFU)/100mL for drinking water standards.

Attribution

Several colleagues aided in making this thesis successful and their contributions are included below:

Mariska Thayagan- helped generate the CFCT Excel spreadsheets used in this project and transferred the ImageJ generated data into the CTCF spreadsheets. Ms. Thayagan also proofed all formular's to ensure their accuracy.

Kevin Rivas Ramos- Mr. Ramos provided the troubleshooting technological expertise in the use of the iPhone® camera as well as initial capability testing of the iPhone® camera in photographing sample imags.

Steve Harris- Mr. Harris was the genuis behind constructing the iPhone® adaptor which housed the fluorescence optics. He sourced out the best materials for constructing the adaptor, located the iPhone® dimension specifications, and precision machined the adaptor during his limited free time. He also provided the electrical expertise in making the LED power supply portable for future studies.

Jonathan Sheldon- provided constructive recommendations when we hit roadblocks with the sample imaging and worked under BSL-2 settings enumerating many cultured plates.

Vasiana Tomco- for working under BSL-2 settings enumerating cultured plates.

TABLE OF CONTENTS

ABSTRACT	I
ATTRIBUTION	II
TABLE OF CONTENTS	III
TABLES.....	VI
FIGURES.....	VI
LIST OF ABBRIVATIONS	VIII
1. INTRODUCTION	1
1.1 MOTIVATION	1
1.2 HYPOTHESIS	2
1.2.1 Goal	2
1.2.3 Objectives.....	2
1.3 EXPERIMENT OUTLINE	3
1.4 REFERENCES	4
2. LITERATURE REVIEW	6
2.1 CURRENT EPA METHODS.....	6
2.1.1 Standard Methods 9222B.....	6
2.1.2 EPA Method 1604.....	8
2.1.3 Colilert 18.....	8
2.1.4 Standard Methods 9221F	9
2.1.5 EnDETEC Tecta® B-16.....	9
2.1.6 Chromocult Coliform Agar	10
2.1.7 M-Coliblu 24	10
2.1.8 E*Colite.....	11
2.2 SOLID PHASE CYTOMETRY	12
2.3 MOLECULAR METHODS.....	13

2.3.1 PCR methods.....	13
2.3.2 Immunological methods.....	15
2.3.3 Nucleic acid hybridization	15
2.4 REFERENCES	17
3. CONJUGATION OF <i>E. COLI</i> 0157:H7 TO FLUOROPHORE	26
3.1 INTRODUCTION	26
3.2 FUNCTIONALIZATION OF GLASS SUBSTRATE.....	26
3.3 IMMOBILIZATION OF ANTIBODY ONTO GLASS SUBSTRATE.....	28
3.4 REFERENCES	32
4. FLUORESCENT IMMUNOASSAY FOR <i>E. COLI</i> 0157:H7 IN WATER.....	39
4.1 ABSTRACT.....	39
4.2 INTRODUCTION	39
4.3 MATERIALS AND METHODS.....	40
4.3.1 Preparation of primary bacterial cultures	40
4.3.2 Preparation of cultures for cryogenic storage	41
4.3.3 Preparation of bacterial stock cultures	41
4.3.4 Preparation of bacterial working cultures	42
4.3.5 Preparation of 1x Phosphate Buffered Saline	42
4.3.6 Preparation of bacterial suspensions using McFarland Solution	43
4.3.7 Alternate method to McFarland Solution.....	43
4.3.8 Preparation of Wash Buffer.....	44
4.3.9 Preparation of Blocking Buffer	44
4.3.10 Preparation of Secondary Incubation Buffer.....	45
4.3.11 Preparation of Tris-Hydrochloride	45
4.3.12 Preparation of BS3	46
4.3.13 Preparation of 3-aminopropyltriethozysilane solution (2%v/v).....	47
4.3.14 Preparation of <i>E.coli</i> 0157:H7 primary and secondary antibodies.....	47
4.3.15 Preparation of Qdot 624 conjugated Streptavidin.....	48
4.3.16 Membrane filtration method.....	49

4.3.17 Fluorescence detection equipment	49
4.3.18 Fluorescence detection software	50
4.4 RESULTS	51
4.5 DISCUSSION	54
4.6 CONCLUSION	58
4.7 REFERENCES	60
5. FUTURE DIRECTIONS.....	63
5.1 CONCENTRATING THE TEST SAMPLE	63
5.2 METHOD SIMPLIFICATION	64
5.3 ANALYTICAL SOFTWARE.....	64

LIST OF TABLES AND FIGURES

III. TABLES	63
TABLE 1: EPA APPROVED DRINKING WATER METHODS FOR DETECTION OF <i>E. COLI</i>	63
TABLE 2: <i>E. COLI</i> 0157:H7 LOG(CFU/0.1ML) AND CORRECTED TOTAL CELL FLUORESCENCE (CTCF).....	64
TABLE 3: <i>E. COLI</i> 0157:H7 (CFU/0.1ML) AND CORRECTED TOTAL CELL FLUORESCENCE (CTCF).....	64
TABLE 4: <i>E. AEROGENES</i> (CFU/0.1ML) AND CORRECTED TOTAL CELL FLUORESCENCE (CTCF).....	64
IV. FIGURES.....	65
FIG.1 STRUCTURE OF (3-AMINOPROPYL) TRIETHOXYSILANE	65
FIG 2 3-AMINOPROPYLTRIETHOXYSILANE (APTES) FUNCTIONALIZATION OF GLASS SUBSTRATE	65
FIG.3 THE DESIGN OF ANTIBODY-SURFACE IMMOBILIZATION AND ANTIBODY-SAMPLE- CONJUGATE ASSAY	66
FIG.4 STRUCTURE OF A QDOT BIOCONJUGATE.....	67
FIG. 5 STRUCTURE OF BIS(SULFOSUCCINIMIDYL) SUBERATE	67
FIG. 6 STRUCTURE OF BIOTIN	68
FIG. 7 BACTERIA FLUORESCENCE LABELING FLOW CHART	69
FIG. 8 WORKING BACTERIAL DILUTION SUSPENSION PREPARATION USING THE MCFARLAND STANDARD LATEX EQUIVALENT #0.5 SOLUTION	70
FIG. 9 TYPICAL MEMBRANE FILTER SETUP	70
FIG 10 IPHONE® 6S ADAPTOR- TOP VIEW	71
FIG. 11 IPHONE® 6S ADAPTOR- FRONT VIEW.....	71
FIG .12 TYPICAL SAMPLE FLUORESCENCE IMAGE PROCESSED WITH IMAGEJ PARTICLE ANALYZER SOFTWARE.....	72
FIG.13 SERIAL DILUTION AND TEST SAMPLE ALIQUOT SAMPLING PLAN	73
FIG 14 EXCITATION AND EMISSION SPECTRA OF FIVE DIFFERENT QDOT FLUOROPHORES	74

FIG. 15 FLUORESCENCE EQUIPMENT SHOWING SAMPLE VIAL HOLDER, LENS AND FILTER	75
FIG 16 FLUORESCENCE EQUIPMENT WITH LIGHT COVER MOUNTED ON IPHONE® 6S ADAPTOR	75
FIG 17 BACTERIA FLUORESCENCE INTENSITY PROCESSING FLOW CHART.....	76
FIG 18 REGRESSION ANALYSIS OF DOSE RESPONSE OF <i>E.COLI</i> 0157:H7 LOG (CFU/0.1ML) AND FLOURESCENCE INTENSITY (CTCF)	77
FIG.19 DOSE RESPONSE OF SPIKED <i>E.COLI</i> 0157:H7 (LOG CUF/0.1ML) AND FLUORESCENCE INTENSITY	78
FIG.20 DOSE RESPONSE OF SPIKED <i>E.COLI</i> 0157:H7 (CUF/0.1ML) AND FLUORESCENCE INTENSITY	78
FIG.21 REGRESSION ANALYSIS OF DOSE RESPONSE OF <i>E.COLI</i> 0157:H7 (CFU/0.1ML) AND FLOURESCENCE INTENSITY (CTCF)	79
FIG.22 REGRESSION ANALYSIS OF DOSE RESPONSE OF <i>E.AEROGENES</i> (CFU/0.1ML) AND FLOURESCENCE INTENSITY (CTCF).....	80
FIG. 23 DOSE RESPONSE OF SPIKED <i>E.AEROGENES</i> CFU/0.1ML AND FLUORESCENCE INTENSITY.....	81

LIST OF ABRIVATIONS

APTES	3-(Aminopropyl)triethoxysilane
PBS	Phosphate Buffered Saline
BS3	Bis(sulfosuccinimidyl)suberate
BSA	Bovin Serum Albumin
PBW	Phosphate Buffered Water
CFU	Colony Forming Units
CTCF	Corrected Total Cell Fluorescence
EA	<i>Enterobacter aerogenes</i>
EC	<i>Escherichia coli</i> 0157:H7
EPA	Enviromental Protection Agency (US)
FDA	Food and Drug Administration (US)
ISO	International Organization for Standardization
LOD	Level Of Detection
MF	Membrane Filtration
MUG	4-Methylumbelliferyl- β -D-glucuronide
nm	Nanometer
ONPG	<i>o</i> -Nitrophenyl- β -D-galactopyranoside
P-A	Presence-Absence
PCR	Polymerase Chain Reaction
PWS	Public Water System
QD/Qdot	Quantum Dot
SM	Standard Methods
SPC	Solid Phase Cytometry
TCR	Total Coliform Rule
VBNC	Viable But Non-Culturable
WHO	World Health Organization

Chapter 1: Introduction

1.1 Motivation

Even though the United States has a robust drinking water program lead by the EPA, 32 reported illness outbreaks were associated with drinking water during the 2011-2012 reporting period, including 3 outbreaks caused by non-Legionella bacteria and 56 cases associated with Shiga-toxin producing *E.coli* bacteria (1). In 2000 the town of Walkerton, Ontario Canada made headlines when 6 people died and over 2000 cases as a result of drinking water tainted with *E.coli* 0157:H7 (2). The World Health Organization (WHO) has shown global concern about *E.coli* 0157:H7 as a source of bloody diarrhea leading to morbidity and mortality amongst children in Africa (2).

The EPA in its Revised Total Coliform Rule, 78 FR 10269, set a zero tolerance for *E.coli* in drinking water (3) and the US Food Drug Administration (FDA) deems bottled water adulterated for the presence of *E.coli* outlined in 21CFR165.110 (4). The USDA (Part 561) has set a zero tolerance for *E.coli* in water consumed by calves , less than 10 CFU/100mL for adult livestock and <1 CFU/100mL for water used for washing food products or food handling equipment (5).

The approved EPA method 1103.1 for the detection of *E.coli* by membrane filtration (MF) using thermotolerant *E.coli* media (mTEC) (6) requires the use of 33 different equipment and supplies excluding reagents, media and method control standards. EPA method 1103.1 requires a skilled analyst proficient in microbiological techniques for performing the analysis and enumeration of *E.coli*. This method requires an initial 2 hour incubation at 35°C with the plates then being transferred to a 44.5°C

water bath for 22 hours and at the end of the incubation period, the membrane filter is transferred onto a previously saturated pad with urea substrate medium for an additional 20 minutes. For *E.coli* verification, the colonies are then streaked onto nutrient agar and incubated at 35°C for 24 hours. Thereafter the colonies are transferred to Simmons Citrate agar (incubated for 4 days @35°C), EC broth (incubated for 24 hours @ 44.5°C), and tryptone water (incubated for 22hours @ 35°C). The total time for *E.coli* confirmation via EPA method 1103.1 is approximately 144 hours.

The EPA method 1604 for the detection of *E.coli* detection by membrane filtration (MF) requires the use of MI agar (7) and requires 29 different equipment and supplies excluding, media and method control standards. EPA method 1604 requires high level of skill and proficiency to perform and enumerate the plates. But the advantage of the method is that it requires 24 hours incubation at 35±0.5 °C. The current norm of between 1-4 days to obtain *E.coli* confirmation in drinking water is not the best practice especially when corrections in real time are critical and could be the difference in a fatality or not.

1.2 Hypothesis

Fluorescence resulting from anti-*E.coli* 0157:H7 antibody and fluorophore reaction can be used for low level detection of *E. coli* 0157:H7 in water.

1.2.1 Goal

To develop a portable field based system to capture and detect *E.coli* 017:H7 in drinking water in less than 60 minutes.

1.2.2 Objectives

1. To functionalize the glass substrate using the sandwich method for conjugating primary and secondary *E.coli* 0157:H7 antibodies.
2. To challenge the assay to detect *E.coli* 0157:H7 at the EPA drinking water LOD of 1 CFU/100mL.
3. To use a cell phone to detect the anti-*E.coli* 0157:H7 antibody-fluorophore reaction.
4. To develop a cell phone application (app) that could be used as a stand-alone unit for detecting the antibody-fluorophore reaction.

1.3 Experiment outline

Chapter 1 encompasses the motivation of my research project highlighted by the large number of cases of morbidity and mortality associated with consumption of *E.coli* 0157:H7 tainted water. The current FDA, EPA and USDA water quality tolerances and current standard methods for the detection of *E.coli* in water are provided. My current work hypothesis is offered. Chapter 2 provides a literature review of *E.coli* detection in water. Approved EPA standard methods to detect *E.coli* in drinking water are outlined as the best practice for water quality. Alternate methods are also provided. Chapter 3 introduces methods for conjugation of fluorophores and antibodies onto the glass substrate. Chapter 4 provides a manuscript containing the analysis to screen *E.coli* 0157:H7 from water to meet the EPA's LOD for *E.coli* in drinking water. Chapter 5 concludes my work and provides the challenges and future directions for this work.

1.4 References

1. Beer, K.D., Gargano, J.W., Roberts, V.A., Hill, V.R., Garrison, Kutty P.K., Hilborn, E.D., Wade, T.J., Fullerton, K.E., and Yoder, J.S., Outbreaks Associated With Environmental and Undetermined Water Exposures — United States, 2011–2012. *August 14, 2015/ 64(31):849-851.*
2. Müller, E. E., Ehlers, M. M., & Grabow, W. O. K. (2001). The occurrence of *E. coli* O157: H7 in South African water sources intended for direct and indirect human consumption. *Water Research, 35(13)*, 3085-3088. doi:10.1016/S0043-1354(00)00597-2.
3. Environmental Protection Agency. Revised Total Coliform Rule And Total Coliform Rule. EPA.gov. <https://www.epa.gov/dwreginfo/revised-total-coliform-rule-and-total-coliform-rule>. Published 13 February 2013. Accessed 20 February 2017.
4. Food and Drug Administration. CFR - Code of Federal Regulations Title 21. <https://www.accessdata.fda.gov/scripts/cdrh/cfdocs/cfcfr/CFRSearch.cfm?fr=165.110>. Published 1 April 2017. Accessed 15 April 2017.
5. U.S. Department of Agriculture. Part 651 Agricultural Waste Management Field Handbook. <https://policy.nrcs.usda.gov/OpenNonWebContent.aspx?content=31473.wba>. Published 31 July 2009. Accessed 5 March 2017.
6. Environmental Protection Agency .Method 1103.1: *Escherichia coli* (*E. coli*) in Water by Membrane Filtration Using membrane-Thermotolerant *Escherichia coli* Agar (mTEC). https://www.epa.gov/sites/production/files/2015-08/documents/method_1103-1_2010.pdf. Published March 2010. Accessed 5 March 2017.

7. Environmental Protection Agency . Method 1604: Total Coliforms and *Escherichia coli* in Water by Membrane Filtration Using a Simultaneous Detection Technique.https://www.epa.gov/sites/production/files/2015-08/documents/method_1604_2002.pdf.

Chapter 2: Literature Review

2.1 Current EPA methods for *E. coli* detection in drinking water

US federal regulation 40 CFR 141, the Total Coliform Rule (TCR), requires Public Water Systems (PWS) that produce and distribute drinking water to be free of fecal contamination and monitor their drinking water quality by monitoring for *E.coli* (1). Bacteria such as *E.coli* are an important hygiene indicator for verification of the performance of a PWS treatment processes and its associated distribution system.

2.1.1 Standard Methods (SM) 9222B

Traditional microbial methods for enumerating *E.coli* in drinking water are the multiple tube fermentation (MTF) and membrane filtration (MF) methods. As drinking water meeting potable water standards are normally free of coliforms, the EPA approved Standard Methods (SM) 9222B is a favored standard by environmental testing laboratories, with SM 9222G being used for *E.coli* verification. The SM 9222B method requires a minimum of 100mL of drinking water filtered through a sterile 47mm, 0.45µm polyethersulfone (PES) or mixed cellulose membrane filter. If there are any *E.coli* or coliform bacteria present in the water sample, the bacteria will be trapped on the membrane filter as a result of the electrostatic interactions and size exclusion mechanism of the membrane filter (3). The membrane filter is then transferred to m-Endo agar and incubated at 35±0.5 °C for 22-24 hours. Colonies that are pink to dark red in colour with a metallic sheen are classified as typical coliform bacteria, and those considered atypical may be dark red, mucoid, or nucleated without sheen (4). For drinking water, both typical and atypical colonies need to be verified if these are confirmed coliform or not with further confirmation for *E.coli* presence.

The coliform confirmation is performed either by the lactose fermentation or by an alternative rapid coliform analysis. For lactose fermentation, each colony of bacteria on the membrane filter is picked and simultaneously inoculated into lauryl tryptose broth, containing a Durham tube, and brilliant green lactose broth and incubated at $35\pm 0.5^{\circ}\text{C}$ for 48h. Gas formation in the lauryl tryptose broth can be seen as a gas bubble inside the submerged Durham tube. Turbidity and gas formation in Durham tube submerged in the brilliant green lactose broth (BGLB) and gas formation in lauryl tryptose broth (LTB) is confirmation of coliform bacteria. For the confirmation of *E.coli*, a colony from brilliant green lactose broth is inoculated into EC both with added 4-methylumbelliferyl- β -D-glucuronide (MUG). For the alternative rapid coliform confirmation, a colony of the membrane filter is tested for cytochrome oxidase and inoculated into *o*-nitrophenyl- β -D-galactopyranoside (ONPG). Coliforms are oxidase negative and ONPG positive.

Typical or atypical coliform colonies are streaked or placement of the entire membrane filter onto NA-MUG (Nutrient Agar with 4-methylumbelliferyl- β -D-glucuronide) which is incubated at 35°C for 4 hours, is examined for fluorescence using an ultraviolet light at 366-nm. Any fluorescence observed on the outer edge of the colony or from the backside of the NA-MUG plate together with negative cytochrome oxidase reaction and positive ONPG, is considered as the presence of *E.coli*. (5). The substrate 4-methylumbelliferyl- β -D-glucuronide (MUG) incorporated into Nutrient Agar (NA) in the presence of the *E.coli* enzyme β -glucuronidase, cleaves MUG to release 4-methylumbelliferone (6) which when exposed to ultraviolet light at 366-nm exhibits fluorescence compared to non-*E.coli* colonies.

2.1.2 EPA Method 1604

The EPA method 1604, Total Coliforms and *E.coli* in Water by Membrane Filtration Using a Simultaneous Detection Technique, makes use of MI agar containing two enzyme substrates, 4-Methylumbelliferyl- β -D-Galactopyranoside (MUGal) and Indoxyl- β -D-Glucuronide (IBDG), incorporated into the medium (7). 4-Methylumbelliferyl- β -D-Galactopyranoside (MUGal) is a fluorogenic substrate (8) and Indoxyl- β -D-Galactopyranoside a chromogenic reagent (9) used for the rapid detection of *E.coli* in water. A solution of cefsulodin an antibiotic that prevents the growth of non-targeted organisms on MI agar or MI broth is included in the media (10). A 100mL water sample is filtered through a 0.45 μ m membrane filter and the membrane filter is transferred to an MI agar plate and incubated at 35°C for 24 hours. Blue colonies on the MI plate is the considered as *E.coli*, with a further confirmation being provided by exposing the plate to 366nm UV light and counting all blue/green fluorescent bacteria as *E.coli* (7). EPA Method 1604 exhibited a false-negative and false-positive rate of 4.3% (11).

2.1.3 Colilert-18

The US-EPA and European Commission (EU) whose members follow the ISO 9308-2:2002 standard for drinking water, have approved IDEXX Laboratories Colilert-18 defined substrate technology for the detection of *E.coli* in drinking water (12). The Colilert-18 presence/absence (P-A) method has simplified *E.coli* testing of drinking water and has been adopted by many environmental testing laboratories as it requires minimal laboratory skill. Colilert-18 uses *o*-nitrophenyl- β -D-galactopyranoside (ONPG) and MUG as substrates. For *E.coli* analysis, a packet of Colilert-18 medium, containing ONPG and

MUG, is added to 100mL drinking water sample in a sterile container. The inoculated sample container is incubated at 35°C for 20 minutes in a water bath to raise the sample to 33-38°C. For the remaining 18 hours the sample is incubated at 35±0.5°C. A yellow colony colour and fluorescence at 365nm is compared against the colour comparator and a reaction ≥ the colour comparator is indicative of *E.coli*. When comparing Colilert-18 to the gold standard reference-Standard Methods (SM) 9222D, Colilert gave a lower false-negative rate at 7%, with Colilert-18 showing a greater method accuracy when compared to SM 9222D (13).

2.1.4 Standard Methods 9221F

Standard Methods 9221F i.e. *Escherichia coli* Procedure (Proposed) utilizes EC-MUG medium in which *E.coli* grown at 44.5±0.2°C for 24±2 h cleaving MUG releasing a fluorogen (14). Fermentation tubes showing growth, gas, or acidity in fermentation tubes after 48± 3 h incubation is inoculated into EC-MUG medium and incubated in a water bath or incubator at 44.5±0.2°C for 24±2 h. Growth and a bright blue fluorescence under a UV lamp at 366 nm wavelength is positive confirmation of *E.coli*. SM 9222F takes a total of 67-77 hours incubation is required for a positive *E.coli* confirmation.

2.1.4 EnDETEC Tecta™ B-16 system

The EnDETEC Tecta™ B-16 system is an EPA approved presence/absence (PA) method for detection of *E.coli* in drinking water. 100mL drinking water sample is added to a cartridge containing Tecta™ medium, reagents and an embedded light sensor (15). *E.coli* cleaves fluorogenic substrate in the Tecta™ medium which is illuminated by an ultraviolet light source. The fluorescence is detected by the Tecta™ instrument and interpreted as the targeted *E.coli* organism. In the EPA Environmental Technology

Verification Report by Ryan James, et. al, Tecta™ B-16 at 0.5 CFU/100mL only provided a 30% positive confirmation, while the reference method Colilert-18 provided 55% positive confirmation for *E.coli* whilst at 5 CFU/100mL both Colilert-18 and Tecta™ provided 100% positive confirmation for *E.coli* (15). However, the EPA standard is <1cfu/100mL.

2.1.6 Chromocult® Coliform Agar

EMD Millipore's Chromocult® Coliform Agar (CCA), is a presence/absence membrane filtration filter test method for the detection of *E.coli* in finished water. CCA meets the ISO 9308-1:2014 methodology for enumeration of *E.coli* using membrane filtration for waters with low bacterial background flora (16). 100mL of water sample is filtered via a 0.45µm nitrocellulose membrane filter, and the membrane filter placed on a CCA plate. The plate is incubated at $36 \pm 2^{\circ}\text{C}$ for 18-24 hours. All colonies that are dark blue to violet are interpreted to be *E.coli* (17). Performance validation of CCA for water borne *E.coli* yielded a 93.8% method sensitivity, 97.4% method specificity, and 96.4% method productivity (18). A drawback of reading *E.coli* on CAA, is when non-*E.coli* counts exceed 1000 CFU/100mL, *E.coli* is difficult to differentiate among atypical colonies (19), making CCA best suited for drinking water with very low microbial counts. CCA has also shown potential for *E.coli* testing of water in temperate regions (20).

2.1.7 m-ColiBlue24

HACH Company's m-ColiBlue24 Broth method for analyzing *E.coli* is an approved EPA method for the simultaneous enumeration of both coliforms and *E.coli* in drinking water within 24 hours. When performing the m-ColiBlue24 procedure blue

colonies are considered as *E.coli* colonies as a result of the reaction between the enzyme beta-glucuronidase and 5-bromo-4-chloro-3-indolylbeta-D-glucuronide when incubated at 35 ± 0.5 °C for 24 hours (21). It has been reported that the reaction of reaction between the enzyme beta-glucuronidase and 5-bromo-4-chloro-3-indolylbeta-D-glucuronide when incubated at 43.5 for 18-22 hours, can result in both blue and blue-green colonies which are considered as *E.coli* confirmation (22).

When using m-ColiBlue24, the tip of a single m-ColiBlue24 Broth ampule tip is broken and the liquid aseptically used to saturate a sterile 47mm absorbent pad located in a pre-sterilized 9x55mm Petri Dish. For drinking water, 20mL aliquot of water is membrane filtered using a vacuum assisted filtration device. Rinse the MF unit using 20-30mL sterile buffered dilution water and the membrane filter is then transferred onto the m-ColiBlue24 Broth saturated pad. The petri dish is then incubated at 35 ± 0.5 °C for 24 hours. Colonies showing a blue colouration 24 hours incubation are considered to be *E. coli* (23). The CFU/20mL obtained is then multiplied by 5 to give the results in the EPA accepted norm, CFU/100mL. A major disadvantage of this method is the use of a 20mL aliquot instead of the 100mL EPA for drinking water analysis. M-ColiBlue24 Broth has been shown to have a 23% failure rate (24).

2.1.8 E*Colite

E*Colite by Charm Sciences, Inc. is a presence-absence test for *E.coli* detection in drinking water by utilizing an enzyme substrate reaction. 100mL drinking water sample is added to an E*Colite sample bag containing resuscitation carbohydrate and fluorescent media for the growth of *E.coli* bacteria (25). E*Colite uses substrates such X-Gal, 5-bromo-4-chloro-3-indolyl- β -D-galactoside, and MUG. X-Gal upon hydrolysis by

β -galactosidase forms a coloured compound, whilst MUG is cleaved by β -D glucuronidase to form a blue colour under 365-366 nm ultraviolet light (26). The inoculated E*Colite bag is incubated at 35°C for 28 hours and blue fluorescence at 366 nm indicates the presence of *E.coli*. Robert and Salter (2006) studying E*Colite for juice testing revealed an acceptable correlation meeting the FDA-BAM MPN standard method, but observed fluorescence at 366 nm by 48 hours incubation at 35°C (26).

2.2 Solid Phase Cytometry for detection of *E.coli* in drinking water

Solid Phase Cytometry (SPC) for the enumeration of *E.coli* in drinking water utilizes fluorescently labelled *E.coli* immobilized on a 25 mm 0.4 μ m polyester track-etched membrane filter which is then enumerated within 3 minutes by a laser scanning device (27). The BioMérieux RDI is a typically used laser scanning device for solid phase cytometry enumeration. A water sample is membrane filtered through a 0.4 μ m polyester track-etched membrane, with the pad being saturated with activation solution. The MF pad is then saturated with labelling solution and scanned for 3 minutes, enumerating the fluorescent cells. Nelis in a patented method, number US5861270A, introduced a two-step process, whereby the sample is concentrated on a membrane filter which is then placed on medium containing nutrients, β -galactosidase or β -glucuronidase and non-specific bacterial growth inhibitors (28). The membrane is then placed in a solution of fluorescent labeling solution and incubated and the fluorescent cells enumerated. The SPC method when compared to the reference methods using mFC agar and Chromacult Coliform Agar (CCA), showed a correlation of 90.6% and 91.7% respectively (29). SPC in combination with fluorescent staining has also shown potential to detect viable but non-culturable (VBNC) in drinking water (30). The EPA reported that

the BioMérieux RDI SPC method detected lower than 10% of *E.coli* fluorescent cells and as a result have not approved SPC for the detection of *E.coli* in drinking water (31).

2.3 Molecular methods for detection of *E.coli* in drinking water

The necessity of rapid analysis for the detection of *E.coli* in drinking water has led to development of molecular methods, such a PCR, immunological and hybridization methods, with increased sensitivity and selectivity for *E.coli*.

2.3.1. PCR Methods

Polymerase chain reaction (PCR) is a well-established molecular tool. PCR with two appropriate primer sequences can be used to amplify small amounts of DNA for molecular analysis (32). One disadvantage of PCR techniques is attributed to the use of micro-liters (μL) of sample compared to the 100mL EPA requirement for drinking water analysis (33). Generally PCR technology does not distinguish between live and dead cells but it does permit the detection of viable but non culturable (VBNC) bacteria (34). It has been reported by the EPA that the use of propidium monoazide may allow the quantification of live cells (35). Bastholm et.al (2008) showed that a minimum of 26 CFU *E.coli* cells were needed for PCR *E.coli* detection (36) which does not meet the EPA or FDA standard for <1 CFU/100mL. Loge *et al.* (2002), showed that only 22% of their samples analyzed using PCR methodology produced a positive result for *E.coli* ETEC (37). Multiplex PCR using the *uidA* gene, which codes for the 3-glucuronidase enzyme in *E.coli* has shown greater promise for the detection of *E.coli* in water (38). It has been shown that the multiplex PCR method has a potential to detect *E. coli* which are not detected by traditional MUG-based methods (39) making this a superior analytical tool. The EPA has approved method 1611 for the detection of Enterococci in water by TaqMan® Quantitative

PCR reaction. Unlike traditional PCR methodology, EPA qPCR method 1611 requires the water sample be filtered on polycarbonate membrane filters to collect the targeted organism. The filtrate is then analyzed using the TaqMan® probe system and TaqMan® Universal master mix PCR reagents (40). The sensitivity of genetic methods is influenced by quality of the water sample thus sample preparation is key to the limitation of PCR methodology (41).

2.3.2 Immunological Methods:

Immunological methods, utilizing antibodies (Ab), such as ELISA (Enzyme-Linked ImmunoSorbent Assay), Lateral Flow Assay (LFA) and Surface Plasmon Resonance (SPR) have been powerful analytical tools for pathogen detection in foods. ELISA analysis detection limits of 10^3 - 10^4 CFU/mL (42) exceeds the EPA <1cfu/100mL *E.coli* norm for drinking water, making this an unsuitable method for detection of *E.coli* in drinking water. Indirect ELISA methodology was shown to have an *E.coli* in water level of detection of 10^4 CFU *E.coli*/L. The advantages of ELISA for testing drinking water is a result within 6-7 hours as well as having a good correlation when compared to traditional gold standard methods (43). Lateral Flow Assay (LFA) has been used in many diagnostic applications, such as the pregnancy test, and has shown promise for use in *E.coli* detection in water based applications. LFA works by the separation of components of a liquid sample through a chromatograph system (44). The entire immunological chromatograph system is located on a strip of polymer material (45). The LFA level of detection (LOD) for *E.coli* 0157:H7 was shown to be 10^6 CFU/mL (46). The surface plasmon resonance (SPR) methodology measures and quantifies molecular binding of proteins between those immobilized on the surface and those in solution. (47).

It was shown that a LOD of 3 CFU *E.coli*/mL was possible with SPR and this method yielded an acceptable correlation when compared to current gold standard techniques (48). The advantages of SPR was the near real time detection of *E.coli* taking approximately 30 minutes to obtain a result with the biosensor having the potential of being reusable (49).

2.3.3 Nucleic acid hybridization methods:

Nucleic acid hybridization methods for the detection of *E.coli* in water relies on the binding of nucleic acid probes to complementary nucleic acid. The key mechanism to this methodology is the denaturing and annealing of complementary DNA or RNA molecules (50). Most nucleic acid hybridization techniques use DNA probes as it allows for ease of synthesis and stability (51) and offers a level of sensitivity and selectivity enabling DNA probes to detect down to a single molecule per cell (52). Peptide nucleic acid (PNA) probes have a pseudo-peptide polymer as a backbone unlike DNA which a phosphate backbone, making this backbone structure the basic difference between PNA and DNA (53). This similarity makes PNA a DNA mimic, which has made it a choice in nucleic acid hybridization for *E.coli* detection (54). PNA combined with chemiluminescent have been used for the enumeration and confirmation of *E.coli* within 12 hours (55). The initial method follows EPA Standard Methods 9222B, to concentrate *E.coli* onto the membrane filter. The membrane filter was transferred to Tryptic Soy Agar (TSA) and incubated for 5 hours at 35°C. The micro colonies on the membrane filter were then hybridized with a soy-bean peroxide conjugated PNA probe, with the hybridized membrane being transferred to a chemiluminescent medium, exposed to X-ray film and thereafter enumerated (56). This method showed a 95% correlation when

compared to standard plate counts (57). A significant disadvantage with nucleic acid hybridization is its complexity which precludes it from being used as a routine test in environmental testing laboratories.

2.4 References

1. Environmental Protection Agency. *E.coli* and Total Coliform Detection in Drinking Water. <https://archive.epa.gov/nrmrl/archive-etv/web/pdf/p100eexn.pdf>. Published April 2012. Accessed 03/01/17.
2. Environmental Protection Agency. Analytical Methods Approved for Compliance Monitoring under the Revised Total Coliform Rule. https://www.epa.gov/sites/production/files/2017-02/documents/rtrc_approved_methods.pdf. Published February 2017. Accessed 03/02/17
3. Lebleu N, Roques C, Aimar P, Causserand C. Role of the cell-wall structure in the retention of bacteria by microfiltration membranes. *Journal of Membrane Science*. 2009; 326(1):178-185.
4. Rice Eugene W (Ed.), Baird RB (Ed.), Eaton AD (Ed.), Clesceri LS(Ed.). Part 9222B Membrane filter technique for members of the coliform group. Standard methods for examination of water and wastewater. 22nd ed. American Public Health Association; 2012.
5. Rice Eugene W (Ed.), Baird RB (Ed.), Eaton AD (Ed.), Clesceri LS(Ed.). Part 9222G Membrane filter technique for members of the coliform group. Standard methods for examination of water and wastewater. 22nd ed. American Public Health Association; 2012.
6. Ekholm DF, Hirshfield IN. Rapid methods to enumerate *Escherichia coli* in foods using 4-methylumbelliferyl-beta-D-glucuronide. *J AOAC Int*. 2001; 84(2):407-415.

7. Environmental Protection Agency. Method 1604: Total Coliforms and *Escherichia coli* in Water by Membrane Filtration Using a Simultaneous Detection Technique (MI Medium). <https://nepis.epa.gov/Exe/ZyNET.exe>. Published September 2002. Accessed 25th April 2017
8. Berg JD, Fiksdal L. Rapid detection of total and fecal coliforms in water by enzymatic hydrolysis of 4-methylumbelliferone-beta-D-galactoside. *Appl Environ Microbiol.* 1988;54(8):2118-212
9. Ley AN, Wolfe S, Bowers RJ. Indoxyl- β -D-glucuronide, a novel chromogenic reagent for the specific detection and enumeration of *Escherichia coli* in environmental samples. *Can J Microbiol.* 1988;34(5):690-693
10. Brenner KP, Rankin CC, Roybal YR, G N Stelma Jr, Scarpino PV, Dufour AP. New medium for the simultaneous detection of total coliforms and *Escherichia coli* in water. *Appl Environ Microbiol.* 1993; 59(11):3534-3544.
11. Sarkar SK, Dutta M, Kumar A, Mallik D, Ghosh AS. Sub-inhibitory cefsulodin sensitization of *E. coli* to [beta]-lactams is mediated by PBP1b inhibition: e48598. *PLoS One.* 2012; 7(11).
12. Chao WL. Evaluation of Colilert-18 for the detection of coliforms and *Escherichia coli* in tropical fresh water. *Lett Appl Microbiol.* 2006; 42(2):115-120.
13. Warden PS, DeSarno MS, Volk SE, Eldred BJ. Evaluation of colilert-18 (R) for detection and enumeration of fecal coliform bacteria in wastewater using the US

environmental protection agency alternative test procedure protocol. J AOAC Int. 2011; 94(5):1573-1580.

14. Eaton, A. D., Clesceri, L. S., Greenberg, A. E., Franson, M. A. H., American Public Health Association., American Water Works Association., & Water Environment Federation. (1998). Standard methods for the examination of water and wastewater. Washington, DC: American Public Health Association
15. TECTATM EC/TC medium and the TECTATM Instrument: a Presence/Absence Method for the Simultaneous Detection of Total Coliforms and *Escherichia coli* in Drinking Water. <http://www.jmcorp.co.kr/new/img/notice/tecta-02.pdf>. Published 22nd May 2014. Accessed 3rd March 2017.
16. Environmental Protection Agency. Environmental Technology verification report- EnDETEC Tecta™ B-16. <https://archive.epa.gov/research/nrmrl/archive-etv/web/pdf/p100ki6o.pdf>. Published February 2007, Accessed 12 April 2017.
17. International Organization for Standardization. ISO 9308-1:2017- Water quality- Enumeration of *Escherichia coli* and coliform bacteria for waters with low bacterial background flora. <https://www.iso.org/standard/55832.html>. Published September 2014. Accessed 10 March 2017.
18. Rattanabumrung O, Sangadkit V, Supanivatin P, Thipayarat A. Kinetics of *E.coli* colony area expansion and color development in chromocult® coliform agar (CCA) under different incubation conditions. Procedia Engineering. 2012; 32:134-140.

19. Lange B, Strathmann M, Oßmer R. Performance validation of chromogenic coliform agar for the enumeration of *Escherichia coli* and coliform bacteria. *Lett Appl Microbiol.* 2013; 57(6):547-553.
20. Maheux AF, Dion-Dupont V, Bisson MA, Bouchard S, Rodriguez MJ. Detection of *Escherichia coli* colonies on confluent plates of chromogenic media used in membrane filtration. *J Microbiol Methods.* 2014; 97:51-55.
21. Vail JH, Morgan R, Merino CR, Gonzales F, Miller R, Ram JL. Enumeration of waterborne *Escherichia coli* with petrifilm plates: Comparison to standard methods. *J Environ Qual.* 2003; 32(1):368-373.
22. Bennell MC, Joyce A, Gardner E, Majury A. An evaluation of Southeastern Ontario recreational water quality. *J Environ Health.* 2015;77(10):26-33
23. Coliform, Total and *E.coli*. <https://www.hach.com/asset-get.download.jsa?id=7639984023>. Published April 2017. Accessed 2nd May 2017.
24. Olstadt J, Schauer JJ, Standridge J, Kluender S. A comparison of ten USEPA approved total coliform/*E.coli* tests. *Journal of Water and Health.* 2007; 5(2):267-282.
25. E*Colite: Test for Total Coliforms and *E. coli* in Potable Water. <https://www.charm.com/products/ecolite#industries>. Published 2010. Accessed 2nd May 2017.

26. Durbin GW, Salter R. Research note: Comparative analysis of a modified Ecolite method, the coli complete method, and a most-probable-number method for detecting *Escherichia coli* in orange juice. J Food Prot. 2006; 69(1):211-213.
27. ABRASP Meeting- Solid Phase Cytometry.
<http://www.abrasp.org.br/downloads/2011/aes.pdf>. Published 20th October 2011.
Accessed 2nd May 2017.
28. Nelis HJ. Enzymatic method for detecting coliform bacteria or *E. coli*. Patent # 5,861,270.<http://patft.uspto.gov/netacgi/nph-Parser?Sect2=PTO1&Sect2=HITOFF&p=1&u=/netahtml/PTO/search-bool.html&r=1&f=G&l=50&d=PALL&RefSrch=yes&Query=PN/5861270>.
Published 19th January 1999. Accessed 3rd May 2017.
29. Van Poucke SO, Nelis HJ. A 210-min solid phase cytometry test for the enumeration of *Escherichia coli* in drinking water. J Appl Microbiol. 2000; 89(3):390-396.
30. Cools I, D'Haese E, Uyttendaele M, Storms E, Nelis HJ, Debevere J. Solid phase cytometry as a tool to detect viable but non-culturable cells of *Campylobacter jejuni*. J Microbiol Methods. 2005; 63(2):107-114.
31. Pyle B.H, A. Camper. Assessment of Microbial Pathogens in Drinking Water using Molecular Methods Coupled with Solid Phase Cytometry.
https://cfpub.epa.gov/ncer_abstracts/index.cfm/fuseaction/display.highlight/abstract/8764/report/F. Published March 2007. Accessed 4th May 2017.

32. Polymerase Chain reaction..<https://www.genome.gov/10000207/>. Published 16th June 2015. Accessed 3rd May 2017.
33. Ashbolt, N. J., Willie O.K. Grabow and Mario Snozz. Assessing microbial safety of drinking water: Improving approaches and methods. OECD; 2003:295.
34. Molina F, Lopez-Acedo E, Tabla R, Roa I, Gomez A, Rebollo J. Improved detection of *Escherichia coli* and coliform bacteria by multiplex PCR. BMC Biotechnology. 2015; 15(1):48.
35. Brenner K.P,K.Oshima,Y.Chu, L.J. Wymer, R.A. Haugland, and E.Chern.A Study of the Various Parameters that Affect the Performance of the New Rapid U.S. Environmental Protection Agency Quantitative Polymerase Chain Reaction (qPCR) Method for Enterococcus Detection and Comparison with Other Methods and Pathogens in Treated Wastewater Mixed with Ambient Water. 2010.EPA/600/R-10/149.
36. Bastholm S, Wahlstrøm L, Bjergbæk LA, Roslev P. A simple bioluminescence procedure for early warning detection of coliform bacteria in drinking water. World Journal of Microbiology and Biotechnology. 2008;24(10):2323-2330
37. Loge FN, Thompson DE, Call DR. PCR detection of specific pathogens in water: A risk-based analysis. Environ Science Technol. 2002; 36(12):2754-2759.
38. A K Bej, J L DiCesare, L Haff, R M Atlas. Detection of *Escherichia coli* and *Shigella spp.* in water by using the polymerase chain reaction and gene probes for uid. Applied and Environmental Microbiology. 1991;57(4):1013-1017.

39. Bej AK, McCarty SC, Atlas RM. Detection of coliform bacteria and *Escherichia coli* by multiplex polymerase chain reaction: Comparison with defined substrate and plating methods for water quality monitoring. *Appl Environ Microbiol.* 1991;57(8):2429-2432
40. Environmental Protection Agency. Method 1611: Enterococci in Water by TaqMan® Quantitative Polymerase Chain Reaction (qPCR) Assay. https://www.epa.gov/sites/production/files/2015-08/documents/method_1611_2012.pdf. Published October 2012. Accessed 23 23rd March 2017.
41. Tanchou, V. Review of methods for the rapid identification of pathogens in water samples. Publications Office of the European Union. 2014. doi:10.2788/18775
42. Deisingh AK, Thompson M. Strategies for the detection of *Escherichia coli* O157:H7 in foods. *J Appl Microbiol.* 2004; 96(3):419-429.
43. Wang N, He M, Shi H. Novel indirect enzyme-linked immunosorbent assay (ELISA) method to detect total *E. coli* in water environment. *Anal Chim Acta.* 2007; 590(2):224-231.
44. Bahadır EB, Sezgintürk MK. Lateral flow assays: Principles, designs and labels. *TrAC Trends in Analytical Chemistry.* 2016; 82:286-306.
45. Posthuma-Trumpie GA, Korf J, van Amerongen A. Lateral flow (immuno) assay: Its strengths, weaknesses, opportunities and threats. A literature survey. *Analytical and Bioanalytical Chemistry.* 2009; 393(2):569-582.

46. Suria MS, Mohd A T Afendy, Azlina NM, Zamri I. Lateral flow assay strip for detection of *Escherichia coli* O157:H7. International Food Research Journal. 2015; 22(6):2587.
47. García-Aljaro C, Muñoz-Berbel X, A. Toby A. Jenkins, Blanch AR, Muñoz FX. Surface plasmon resonance assay for real-time monitoring of somatic coliphages in wastewaters. Appl Environ Microbiol. 2008;74(13):4054-4058
48. Torun O, Hakki Boyaci I, Temuer E, Tamer U. Comparison of sensing strategies in SPR biosensor for rapid and sensitive enumeration of bacteria. Biosensors and Bioelectronics. 2012; 37(1):53-60.
49. Dudak FC, Boyacı İH. Development of an immunosensor based on surface plasmon resonance for enumeration of *Escherichia coli* in water samples. Food Res Int. 2007; 40(7):803-807.
50. Holben WE, Tiedje JM. Applications of nucleic acid hybridization in microbial ecology. Ecology. 1988;69(3):561-568.
51. Theron J, Eugene Cloete T, de Kwaadsteniet M. Current molecular and emerging nanobiotechnology approaches for the detection of microbial pathogens. Crit Rev Microbiol. 2010;36(4):318-339.
52. Alberts B. Molecular biology of the cell. 4th ed. New York: Garland Science; 2002
53. Genet MD, Cartwright IM, Kato TA. Direct DNA and PNA probe binding to telomeric regions without classical in situ hybridization. Molecular Cytogenetics. 2013;6(1):42.
54. Nielsen PE, Egholm M, Buchardt O. Peptide nucleic acid (PNA). A DNA mimic with a peptide backbone. Bioconjugate Chemistry. 1994;5(1):3-7

55. Henrik Stender, Adam J. Broomer, Kenneth Oliveira, et al. Rapid detection, identification, and enumeration of *Escherichia coli* cells in municipal water by chemiluminescent in situ hybridization. *Applied and Environmental Microbiology*. 2001;67(1):142.
56. Perry-O'Keefe H, Stender H, Broomer A, Oliveira K, Coull J, Hyldig-Nielsen JJ. Filter-based PNA in situ hybridization for rapid detection, identification and enumeration of specific micro-organisms. *Journal of Applied Microbiology*. 2001; 90(2):180-189.
57. Rompré, A., Servais, P., Baudart, J., de-Roubin, M., & Laurent, P. (2002). Detection and enumeration of coliforms in drinking water: Current methods and emerging approaches. *Journal of Microbiological Methods*, 49(1), 31-54. doi:10.1016/S0167-7012(01)00351-7

Chapter 3: Conjugation of *E.coli* 0157:H7 antibody to fluorophore

3.1 Introduction

The proper orientation and adhesion of proteins on the glass substrate is a driver for the protein's desired functioning (1) therefore the functionalization of the glass substrate is crucial when used in conjugated antibody assays for rapid detection of pathogens in foods. Adhesion of proteins onto glass substrate encounter significant problems attributed to non-specific protein adsorption (2).

3.2 Functionalization of glass substrate

Functionalization of the glass substrate is a pivotal step in this experiment. Silanization of glass substrates has been commonly achieved using 3-(aminopropyl) triethoxysilane, fig. 1, that has a molecular formula $C_9H_{23}NO_3Si$ and commonly referred to in literature as APTES (3). The user of APTES should follow Good Laboratory Practices (GLP) and the handler should understand the safety implications when working with APTES as it can cause severe skin burns and eye damage including allergic skin reactions whilst APTES dust inhalation must be limited (4). For a more complete health and safety guidance when using APTES, always consult with the manufacturer's Safety Data Sheet (SDS) prior to use. Prior to silanization, the glass substrate should be washed in a sonicator with an alkaline phosphate detergent to remove surface contaminants. For the alkaline phosphate detergent solution to be effective, the solution should be approximately pH 11.5 which at the same time helps form a thin layer of silicon dioxide on the glass surface i.e. siloxane (5). The primary purpose of cleaning the glass substrate is to create a hydrophilic surface (6) and contact angles of less than 8° which indicates uniformity of the silane monolayer (7). Thereafter plasma cleaning is used to remove any

remaining contaminants .Plasma cleaning utilizes either oxygen plasma equipment or UV-ozone plasma equipment (8). An alternative to plasma cleaning can be achieved with Piranha solution. Piranha solution is a mixture of concentrated sulphuric acid with hydrogen peroxide at a 3:1 dilution i.e. $3\text{H}_2\text{SO}_4: 1\text{H}_2\text{O}_2$ (5). Piranha solution being a strong acid and oxidizer is very corrosive and extremely explosive and should not be stored in a closed container as this can amplify its explosive nature. As Piranha solution should never be stored, it has to be freshly made for each use. It is recommended that the handler of Piranha solution receive Good Laboratory Practices (GLP) training so that he/she understands the hazardous nature of Piranha solution and the appropriate personal protective equipment (PPE) required when making and/or using this solution. For Piranha solution Safety, Health and Environmental (SHE) guidance refer to Cambridge University's Chemical Safety Guidance Series (9). Both plasma and strong acid-oxidizer cleaning methods transform the siloxane layer to silanol functional groups that enable APTES interactions (5).

A proposed interaction mechanism of APTES with the glass substrate highlighted in fig. 2, follows an addition-elimination reaction with the silanes reacting with hydroxyl groups on the glass surface with the thin mono-layer of silane deposited onto the glass containing terminal ends of carboxyl, amino or hydroxyl functional groups (10,11,12) . Depending on the amount of water present, the APTES preliminary hydrolysis step can take place either in solution or at the glass surface (13). Silanization of APTES onto the glass substrate follows the Langmuir model of kinetics (14). The structure of the silane layer influences the functional groups reactivity for supplementary coupling reactions that influence the binding of antibody onto the glass substrate (15, 16, 17).

3.3 Immobilization of Antibodies onto glass substrates:

Antibodies cannot be directly attached to glass (18) substrates and as glass formed a major aspect of this experiment, methodology for immobilization of antibodies on glass requires critical review. Antibody immunoassay performance is influenced by the selection of the antibody being used, but is also influenced by immobilization chemical properties and the surface properties of immobilization (19). Typical techniques for immobilization of antibodies that may be used in this study include physical adsorption and covalent coupling immobilization. Other techniques such as oriented antibody immobilization and the use of functional group self-assembly (20) but these methods will not be discussed in this paper.

Based on reviewed literature physical adsorption is the easiest technique for antibody immobilization on solid surfaces. One major disadvantage of physical adsorption is that antibodies are randomly oriented and less than 10% of functionalized antibodies were available for antigen binding (21). Physical adsorption also referred to as physisorption onto glass substrates is primarily through electrostatic interactions (22) and secondarily onto hydrostatic interactions (23). As electrostatic mechanisms are strongly influenced by pH, surface and ionic factors, and temperature, negatively impacts antibody immobilization reproducibility (18). Steric hindrance whereby immobilized proteins are oriented away from the glass surface together with the fact that the interactions are weak compounds the negative aspects of this technique (23). Recent studies have shown that glass surfaces coated with calixarene improves antibody orientation (24). Calixarenes have cup shaped openings with upper and lower rims and the rims are highly configurable into organized structures (25) improving antibody orientation. Sang Wook

Oh, et al. (2005) created a calixarene derivative viz. Prolinker A, for immobilization of antibodies onto glass slides (26). Calxicrown also a calxarene derivative was patented (US Patent publication # US6485984 B1) for its ability to immobilize a protein monolayer and has been cited in a number of Intel Corp.'s biosensor patents (27).

Immobilization of antibodies onto glass substrates via covalent bonds is the most commonly used technique for immobilization of antibodies onto glass substrates (21). Chemical linkers are frequently used for conjugation of antibodies to glass substrates but may at times reduce the antigens functionality to bind to antibodies (28). There has been recent improvements with periodate-oxidization of the carbohydrate functional group located at the antibodies Fc region creating highly reactive aldehydes (29). It has been shown that reduction in stability associated with covalent immobilization can be achieved through the use of homobifunctional linker bis(sulfosuccinimidyl)suberate (30). Glass substrates treated with Streptavidin tends to strongly immobilize biotinylated antibodies and as a result have gained popularity for covalent immobilization of antibodies (21). Recent advances in photometric nucleotide binding site (UV-NBS) which allows for immobilization of antibodies to aromatic rings containing indole-3-butyric acid (31). Mustafaoglu et al. (2015) showed that UV-NBS methodology yielded a significant improvement in antigen detection sensitivity compared to some commonly used immobilization techniques (32). The nucleotide binding site provides an advantage in that it serves as a site for selective immobilization of antibodies (33).

Antibody-binding base immobilization techniques have shown success in immobilizing antibodies to glass substrates. ELISA a gold standard immunoassay used in many laboratories makes use of antibodies attaching to specific molecules. Solid-phase

fluorescent immunoassays (SPFIA), unlike ELISA which utilizes colometric detection, SPFIA relies on spectrophotometric detection. Antibody-binding immuno-assays have been shown to have a greater sensitivity than previously used gold standard antibody immobilization methods (21). In this research the scope is the use of SPFIA methodology utilizing the sandwich technique as shown in fig. 3, in which antibody, antigen, and antibody form a “sandwich” with streptavidin conjugated Quantum Dot (QD) being the fluorescent material of choice. QDs are semiconductor nanomaterial with a diameter of 2-10 nanometers and are tunable (34). The capability of QDs being tuned are unique for QDs in that its energy of excitation stems from its size to fluorescence colour (35). To give some perspective to QDs 2-10 nm size, viruses are between 15-300 nm and bacteria range from 300 nm-750 um (36,37). QDs, fig. 4, consists of three layers; a CdSe core surrounded by two layers of CdS and an outer monolayer of ZnS and wer shown to have superior stability and fluorescence emission than organic dyes (38,39). The QD outer layer may contain conjugation coatings, either ligand-based or polymer-based (40). The polymer-based coating prevents photo oxidation of the luminescent QD core (41). The ligand-based coating serves as a point of attachment for biomolecules (42). There are methods to make QDs but commercially available QDs, even though expensive, are convenient. It has been shown that QDs conjugated with anti-*E.coli* antibodies will only bind to *E.coli* 0157:H7 cells (43).

The functionalization of the glass substrate using APTES creates a silane self-assembled monolayer (SAM) with terminal functional groups for attaching biomolecules. The amine functional groups located on the SAM react with the homobifunctional cross-linker bis(sulfosuccinimidyl)suberate, fig. 5, to form aldehyde functional groups that

react with the antibody's available *N*-acetylperosamine amino group creating the backbone of the SFIA sandwich (44,45,46,47).

Streptavidin is a tetramer protein from the bacterium *Streptomyces avidinii* with binding sites that can accommodate four biotin molecules (48,49). Not only is streptavidin affinity for biotin an advantage in fluorescent labelling but the streptavidin-biotin interaction is a stable interaction (49). The valeric side of biotin shown in fig. 6, contains the carboxyl functional group which help biotin attach to many molecules (49). As used in this experiment biotin is conjugated to primary or secondary antibodies, providing amplification through the interaction and detection of the biotin-streptavidin conjugation to QDs (50). The addition of aminohexanoic acid, a lysine derivative, to the carboxyl functional group of biotin, improves the formation efficiency of the biotinylated antibody, conjugated streptavidin and the fluorescing probe complex (50).

3.4 References

1. Aydin D, Hirschfeld-Warneken VC, Louban I, Spatz JP. Micro- and nanopatterning of active biomolecules and cells. In: *Intelligent surfaces in biotechnology*. John Wiley & Sons, Inc.; 2012:291-319.
2. Bhatia SK, Shriver-Lake LC, Prior KJ, et al. Use of thiol-terminal silanes and heterobifunctional crosslinkers for immobilization of antibodies on silica surfaces. *Analytical Biochemistry*. 1989; 178(2):408-413.
3. National Center for Biotechnology Information. PubChem Compound Database; <https://pubchem.ncbi.nlm.nih.gov/compound/1352121> .
4. Safety Data Sheet.
<https://www.sigmaaldrich.com/MSDS/MSDS/DisplayMSDSPage.do?country=US&language=en&productNumber=440140&brand=ALDRICH&PageToGoToURL=http%3A%2F%2Fwww.sigmaaldrich.com%2Fcatalog%2Fproduct%2Faldrich%2F440140%3Flang%3Den>. accessed 8/12/17.
5. Nicholas MP, Rao L, Gennerich A. Covalent immobilization of microtubules on glass surfaces for molecular motor force measurements and other single-molecule assays. *Methods in molecular biology* (Clifton, N.J.). 2014; 1136:137.
6. Dey T, Naughton D. Cleaning and anti-reflective (AR) hydrophobic coating of glass surface: A review from materials science perspective. *J Sol Gel Sci Technol*. 2015; 77(1):1-27.
7. Cras JJ, Rowe-Taitt CA, Nivens DA, Ligler FS. Comparison of chemical cleaning methods of glass in preparation for silanization. *Biosensors and Bioelectronics*. 1999;14(8):683-688.

8. Labit H, Goldar A, Guilbaud G, Douarche C, Hyrien O, Marheineke K. A simple and optimized method of producing silanized surfaces for FISH and replication mapping on combed DNA fibers. *BioTechniques*. 2008;45(6):649.
9. University of Cambridge. Acid Piranha Solution: User Guidance. <http://www.safety.admin.cam.ac.uk/files/hsd176c.pdf>. Published October 2016. Accessed 16th June 2017.
10. Chechik V, Crooks RM, Stirling C. Reactions and reactivity in self-assembled monolayers. *Advanced Materials*. 2000;12(16):1161-1171.
11. Schlecht CA, Maurer JA. Functionalization of glass substrates: Mechanistic insights into the surface reaction of trialkoxysilanes. *RSC Advances*. 2011;1(8):1446-1448.
12. Cras JJ, Rowe-Taitt CA, Nivens DA, Ligler FS. Comparison of chemical cleaning methods of glass in preparation for silanization. *Biosensors and Bioelectronics*. 1999;14(8):683-688.
13. Howarter JA, Youngblood JP. Optimization of silica silanization by 3-aminopropyltriethoxysilane. *LANGMUIR*. 2006;22(26):11142-11147.
14. Vashist SK, Lam E, Hrapovic S, Male KB, Luong J. Immobilization of antibodies and enzymes on 3-aminopropyltriethoxysilane-functionalized bioanalytical platforms for biosensors and diagnostics. *Chemical Reviews*. 2014;114(21):11083-11130.
15. Wang W, Vaughn MW. Morphology and amine accessibility of (3-aminopropyl)triethoxysilane films on glass surfaces. *Scanning*. 2008;30(2):65-77.
16. Acres RG, Ellis AV, Alvino J, et al. Molecular structure of 3-aminopropyltriethoxysilane layers formed on silanol-terminated silicon surfaces. *Journal of Physical Chemistry C*. 2012;116(10):6289-6297.

17. Yinlan Ruan, Tze Cheung Foo, Stephen Warren-Smith, et al. Antibody immobilization within glass microstructured fibers: A route to sensitive and selective biosensors. *Optics Express*. 2008;16(22):18514-18523.
18. Kim D, Herr AE. Protein immobilization techniques for microfluidic assays. *Biomicrofluidics*. 2013;7(4):41501.
19. Kausaite-Minkstimiene A, Ramanaviciene A, Kirlyte J, Ramanavicius A. Comparative study of random and oriented antibody immobilization techniques on the binding capacity of immunosensor. *ANALYTICAL CHEMISTRY*. 2010;82(15):6401-6408.
20. Jung Y, Jeong JY, Chung BH. Recent advances in immobilization methods of antibodies on solid supports. *ANALYST*. 2008;133(6):697-701
21. Couston RG, Skoda MW, Uddin S, van der Walle, Christopher F. Adsorption behavior of a human monoclonal antibody at hydrophilic and hydrophobic surfaces. *mAbs*. 2013;5(1):126-139.
22. Giri B. Laboratory methods in microfluidics. Elsevier Science & Technology Books; 2017:179
23. Meulenber EP. Antibodies: Applications and new development. 1st ed. Bentham Science; 2012:328
24. Calixarenes. <https://www.alfa.com/en/calixarenes/>. Accessed 10th July 2017.
25. Oh SW, Moon JD, Lim HJ, et al. Calixarene derivative as a tool for highly sensitive detection and oriented immobilization of proteins in a microarray format through noncovalent molecular interaction. *FASEB JOURNAL*. 2005;19(8):1335.

26. Tai-Sun K. Calixcrown derivatives, a process for the preparation thereof, a self-assembled mono-layer of the calixcrown derivatives prepared by using the same and a process for immobilizing a protein mono-layer by using the self-assembled mono-layer of the calixcrown derivatives. <https://www.google.com/patents/US6485984>. Published 26th November 2002. Accessed 8th July 2017.
27. Lee Y, Jeong J, Lee G, Moon JH, Lee MK. Covalent and oriented surface immobilization of antibody using photoactivatable antibody fc-binding protein expressed in *Escherichia coli*. *ANALYTICAL CHEMISTRY*. 2016;88(19):9503-9509.
28. Yuan Y, Yin M, Qian JC, Liu CS. Site-directed immobilization of antibodies onto blood contacting grafts for enhanced endothelial cell adhesion and proliferation. *SOFT MATTER*. 2011;7(16):7207-7216.
29. Trilling AK, Beekwilder MJ, Zuilhof H. Antibody orientation on biosensor surfaces: A minireview. *The Analyst*. 2013;138(6):1619-1627.
30. Alves NJ, Kiziltepe T, Bilgicer B. Oriented surface immobilization of antibodies at the conserved nucleotide binding site for enhanced antigen detection. *LANGMUIR*. 2012;28(25):9640-9648.
31. Mustafaoglu N, Alves NJ, Bilgicer B. Site-specific fab fragment biotinylation at the conserved nucleotide binding site for enhanced ebola detection. *Biotechnol Bioeng*. 2015;112(7):1327-1334.
32. Alves NJ, Champion MM, Stefanick JF, et al. Selective photocrosslinking of functional ligands to antibodies via the conserved nucleotide binding site. *BIOMATERIALS*. 2013;34(22):5700-5710.

33. Quantum Dots. <http://www.sigmaaldrich.com/technical-documents/articles/materials-science/nanomaterials/quantum-dots.html>. Accessed 20th July 2017.
34. Qdot® Nanocrystal Technology Overview .
<https://www.thermofisher.com/us/en/home/brands/molecular-probes/key-molecular-probes-products/qdot/technology-overview.html#size>. Accessed 10th June 2017.
35. Gelderblom HR. Structure and Classification of Viruses. In: Baron S, editor. *Medical Microbiology*. 4th edition. Galveston (TX): University of Texas Medical Branch at Galveston; 1996. Chapter 41.
36. Chien AC, Hill NS, Levin PA. Cell size control in bacteria. *CURRENT BIOLOGY*. 2012;22(9): R349.
37. Zorn G, Dave SR, Gao XH, Castner DG. Method for determining the elemental composition and distribution in semiconductor core-shell quantum dots. *ANALYTICAL CHEMISTRY*. 2011;83(3):866-873.
38. Zhang HQ, Zhao Q, Li XF, Le XC. Ultrasensitive assays for proteins. *ANALYST*. 2007;132(8):724-737.
39. Algar WR, Tavares AJ, Krull UJ. Beyond labels: A review of the application of quantum dots as integrated components of assays, bioprobes, and biosensors utilizing optical transduction. *Analytica Chimica Acta*. 2010;673(1):1-25.
40. Li JJ, Wang YA, Guo WZ, et al. Large-scale synthesis of nearly monodisperse CdSe/CdS core/shell nanocrystals using air-stable reagents via successive ion layer adsorption and reaction. *JOURNAL OF THE AMERICAN CHEMICAL SOCIETY*. 2003;125(41):12567-12575.

41. Goldman ER, Uyeda HT, Mattoussi H, Medintz IL. Quantum dot bioconjugates for imaging, labelling and sensing. *Nature Materials*. 2005;4(6):435-446.
42. Kuo YC, Wang Q, Ruengruglikit C, Yu HL, Huang QR. Antibody-conjugated CdTe quantum dots for *Escherichia coli* detection. *JOURNAL OF PHYSICAL CHEMISTRY C*. 2008;112(13):4818-4824.
43. Nisnevitch M, Kolog-Gulco M, Trombka D, Green BS, Firer MA. Immobilization of antibodies onto glass wool. *Journal of Chromatography B: Biomedical Sciences and Applications*. 2000;738(2):217-223.
44. Vashist SK, Lam E, Hrapovic S, Male KB, Luong J. Immobilization of antibodies and enzymes on 3-aminopropyltriethoxysilane-functionalized bioanalytical platforms for biosensors and diagnostics. *CHEMICAL REVIEWS*. 2014;114(21):11083-11130.
45. Nicholas MP, Rao L, Gennerich A. Covalent immobilization of microtubules on glass surfaces for molecular motor force measurements and other single-molecule assays. *Methods in molecular biology (Clifton, N.J.)*. 2014;1136:137.
46. Lei Wang, Peter R. Reeves. Organization of *Escherichia coli* O157 O antigen gene cluster and identification of its specific genes. *Infection and Immunity*. 1998;66(8):3545-3551.
47. Lim S, Koo OK, You YS, et al. Enhancing nanoparticle-based visible detection by controlling the extent of aggregation. *SCIENTIFIC REPORTS*. 2012;2:456.
48. Dundas CM, Demonte D, Park S. Streptavidin–biotin technology: Improvements and innovations in chemical and biological applications. *Applied Microbiology and Biotechnology*. 2013;97(21):9343-9353.

49. Avidin-Biotin Interaction. <https://www.thermofisher.com/us/en/home/life-science/protein-biology/protein-biology-learning-center/protein-biology-resource-library/pierce-protein-methods/avidin-biotin-interaction.html>. Accessed 21st August 2017.
50. Haugland RP, You WW. Coupling of antibodies with biotin. *Methods in molecular biology (Clifton, N.J.)*. 2008;418:13.

Chapter 4 Fluorescent Immunoassay detection of *E.coli* in water

4.1 Abstract

E.coli 0157:H7 is one of the major bacterial diseases transmitted through drinking water and is a major contaminant on leafy greens. Results from current traditional plating methods including P-A analysis is time consuming and this slow process is an hinderance as a preventive control for food-borne outbreaks. In this experiment a fluorescence immunoassay outlined in fig. 7, is proposed for detecting *E.coli* 0157:H7 in water with a moderate amount of preparatory steps and less than 5 minutes for the detection of this pathogen. In examining the relationship between *E.coli* 0157: H7 CFU/0.1mL to fluorescence intensity, our model data evaluated with Minitab 16, revealed a $P(0.001)= 0$, and $F=271.56$ demonstrating a strong relationship of *E.coli* 0157:H7 detection with this immunoassay. *E.aerogenes* the negative control for the immunoassay revealed a $P(0.001)=0.677$ and $F=0.31$, validating the specificity of the model. *E.coli* 0157:H7 was detected at 1 CFU/0.1mL with the proposed model and least three sigma (3σ) levels above the baseline for the control blank, thereby showing $\geq 99.7\%$ probability of locating *E.coli* 0157:H7 when compared to the experiment control.

4.2 Introduction

Escherichia coli 0157:H7 is a zoonotic pathogen that has been associated with numerous waterborne outbreaks which has led to high morbidity and mortality rates. In the US there were 31 *E.coli* 0157:H7 waterborne outbreaks reported by the CDC between 1998-2002 (1). Majority of *E.coli* waterborne outbreaks have been associated with consumption of untreated or poorly treated groundwater (2). Rapid detection combined with simplicity of analysis for the detection of waterborne *E.coli* 0157:H7 in drinking

water is critical in preventing waterborne outbreaks. Standard Methods for the Examination of Water and Wastewater includes many EPA gold standard methods for examination of *E.coli* in water, many taking 18-48 hours for *E.coli* confirmation. A disadvantage of the EPA methods is that none of these procedures can be performed in a field setting. Thus adding next day transport time to samples to a certified laboratory can add 18-19.5 hours before a sample is processed by the testing lab. The delivery time is based on based on the UPS Next Day Air® Early delivery commitment. It is the objective of this project to meet the WHO ASSURED characteristics for point of use diagnostic tools i.e. Affordable: <\$10/test, Sensitivity/Selectivity: lower detection limit of 1 CFU *E.coli* 0157:H7/100mL, User-friendly: <1 day training with minimal analyst skill level, Rapid and Robust: <60 minutes for *E.coli* 0157:H7 confirmation using anti-*E.coli* 0157:H7 antibody functionalized glass substrate, Equipment Free: onsite analysis and no logistical requirements, and Deliverable: cell phone (3).

4.3 Materials and Methods

4.3.1. Preparation of primary bacterial cultures

The *E. coli* 0157:H7 and *Enterobacter aerogenes* cultures used in this experiment were cultured from lyophilized *E.coli* 0157:H7 Lab-Elite™ CRM KWIK-STIK derived from ATCC® 43888 (Microbiologics, Catalogue #0795-CRM) and *Enterobacter aerogenes* Lab-Elite™ CRM KWIK-STIK derived from ATCC® 13048 (Microbiologics, Catalogue #0306-CRM). The lyophilized cultures were no more than 4 passages from the culture type collection reference culture and stored at a temperature of between 2-8°C. Prior to preparation the lyophilized culture was allowed to equilibrate to the laboratory temperature of 21°C. *E.coli* 0157:H7 ATCC® 43888 is classified as BSL-2 and as safety

is paramount, users need to ensure they are working and adhering to BSL-2 standards. *E.aerogenes* ATCC® 13048 is classified as BSL-1. The KWIK-STIK unit includes a lyophilized pellet of culture, hydrating fluid and swab. Follow the vendor's instructions for hydrating the lyophilized culture (4). The hydrated KWIK STIX swab was then rolled onto one-quarter of the 15mm Tryptic Soy Agar (TSA) plate (Northeast Laboratory Services, #6015-PS). The swabbed area on the TSA plate is considered as the first streak for the culture streak plate technique to achieve primary colony isolation. The primary inoculated TSA plate was incubated at $35\pm 0.5^\circ$ for 18-24 hours.

4.3.2. Preparation of cultures for cryogenic storage

One hundred milliliters of biotechnology grade glycerol (VWR, #97062-452), was added to a 250mL Erlenmeyer flask, capped with foil and sterilized at 121°C for 15minutes. The sterilized glycerol solution was verified to ensure sterility. The sterility check was performed by adding 25mL sterilized glycerol solution to a media culture bottle (VWR # 89000-926) containing 25mL sterile double strength Trypticase Soy Broth (dsTSB) (BD, Item #211771). dsTSB was made using 60g dehydrated TSB to 1L demineralized water and sterilized at 121°C for 15minutes. 0.21mL of sterile glycerol was pipetted into sterile 2mL Nalgene cryogenic vials (VWR Item # 66008-728) to be used in the preparation of cryogenic bacterial stock culture storage vials.

4.3.3. Preparation of bacterial stock culture

Single strength Trypticase Soy Broth (ssTSB) was prepared by adding 30g of dehydrated TSB to 1L demineralized water (TSB final pH 7.3 ± 0.2) and 100mL TSB was dispensed into 250mL Erlenmeyer flasks, capped with foil and sterilized at 121°C for

15minutes. After 18-24 hours of incubation of the primary culture plate, a single *E.coli* 0157:H7 colony was isolated using a sterilized wire loop and inoculated into the Erlenmeyer flask containing the single strength TSB. The inoculated solution was homogenized using a vortex mixer (VWR #97043-564) and incubated at $35\pm 0.5^{\circ}$ for 18-24 hours. After incubation, the TSB/*E.coli* 0157:H7 solution and TSB/*E.aerogenes* solution were mixed to homogenize the turbid solution. Turbidity shows growth of bacteria suspension. The cryogenic stock cultures was made by adding 1.4mL of *E.coli* 0157:H7 propagated in TSB to the cryogenic storage vials containing 0.21mL glycerol (15% v/v final concentration). *E.aerogenes* culture was made by adding 1.4mL of TSB/*E.aerogenes* solution to cryogenic storage vials containing 0.21mL glycerol (15% v/v final concentration). After gentle mixing, the cryovials were stored in a cyrobox (VWR#73520-498) and maintained in a freezer less than -20°C for future use.

4.3.4. Preparation of bacterial working culture

To prepare the working culture, one of each cryopreserved vial of *E.coli* 0157:H7 and *E.aerogenes* stock culture were thawed by placing the cryovial in warm water taking care not to submerge the vial in water as this can possibly lead to cross-contamination. A heat sterilized wire loop was used to remove a loopful of culture to streak onto a TSA plate to obtain isolated colonies. The inoculated TSA plate was incubated at $35^{\circ}\pm 0.5^{\circ}\text{C}$ for 18-24hours. Obtain an isolated colony, using a heat sterilized wire loop and streak onto a TSA plate and incubate at $35\pm 0.5^{\circ}\text{C}$ for 18-24 hours. A second streak plate was performed to ensure purity of colonies. For this experiment, young actively growing colonies were used at 18-20 hours of incubation.

4.3.5. Preparation of sterile phosphate buffered water (PBW)

The phosphate buffered water diluent (PBW) was made by adding one HACH pillow pack of potassium dihydrogen phosphate solution and one HACH pillow pack of magnesium chloride solution , HACH (#2143166), into 1L distill water. 9.9mL aliquots of PBW was dispensed into culture tubes and autoclave sterilized at 121°C for 15 minutes. 900mL volumes of PBW was dispensed into 1L media bottles and autoclave sterilized at 121°C for 30 minutes. Sterilized PBW was stored in a refrigerator at 2-8 °C.

4.3.6. Preparation of *E.coli* 0157:H7 dilutions with McFarland Standard

Three vials of McFarland Standard latex equivalent #05 solution manufactured by Hardy Diagnostic (Cat. # ML-05) was purchased from VWR (cat. # 89426-218). Each 8mL McFarland solution vials was added into a 25mL HACH turbidity sample vial (HACH, #24019-06) to the 20mL test mark. Colonies from the *E.coli* 0157:H7 working culture plate were inoculated into 20mL sterile PBW to have a comparable visual turbidity to that of the McFarland Standard latex equivalent #05 solution. Once the visual standards were obtained, the 20mL McFarland Standard and 20mL *E.coli* 0157:H7 solution were tested for absorbance using a HACH DR3900 spectrophotometer, fig. 8. To ascertain the concentration of the bacterial solution compared to the McFarland Standard, a 0.1ml aliquot of the *E.coli* 0157:H7 solution was added to 9.9ml PBS. The dilution was mixed using a vortex mixer at 2200 rpm for 20 seconds. Using 0.1ml aliquots to 9.9mL PBW, four additional serial solutions were prepared. Dilution #3 and dilution #4 were enumerated by membrane filtering 100µL aliquots with the membrane filter transferred to TSA plates and incubated at 35±0.5°C for 18-24 hours.

4.3.7. Alternate method for preparation of bacterial suspensions

A single isolated colony of *E.coli* 0157:H7 was removed from the working culture plate using a heat sterilized wire loop and inoculated into sterile culture tubes containing 10ml of PBW. This was also carried out for *E.aerogenes* culture. The inoculated culture tube was then vortex mixed at 2200rpm for 20 seconds - this culture tube was labeled as dilution A. 0.1ml of the homogenized bacterial solution from dilution A was transferred to 9.9ml PBW and vortex mixed for 20 seconds at 2200rpm and labeled as dilution B (10^{-2} serial dilution). A 0.1ml aliquot was removed from dilution B and transferred to a 9.9ml PBW and the suspension labeled as dilution C (10^{-4} serial dilution). After vortex mixing at 2200rpm for 20 seconds, a 0.1mL aliquot was removed from dilution C and transferred to 9.9mL PBW labeled as dilution D (10^{-6} serial dilution). 100 μ L of the appropriate serial dilution was then membrane filtered with the membrane filter placed on a TSA plate and incubated at $35\pm 0.5^{\circ}\text{C}$ for 18-24 hours and enumerated.

4.3.8. Preparation of Wash buffer

Prepared the sterile wash buffer (1x phosphate buffered saline) by adding 100mL of MilliporeSigma 10x PBS (VWR #EM-6506) to 900mL sterilized Deionized water (DI) water (0.70 μ S) in a 1L pre-sterilized media bottle (VWR #10754-820). When not in use, the sterile 1x PBS 10mM solution was stored refrigerated at 2-8 $^{\circ}\text{C}$. To assure sterility, the 1x PBS solution was sterility checked by adding 50mL PBS to 50mL sterilized double strength Trpticase Soy Broth (dsTBS) and incubated at $35\pm 0.5^{\circ}\text{C}$ for 48 hours, examining for absence of turbidity.

4.3.9. Preparation of Blocking buffer

4.3.9.1 Gelatin blocking buffer (2%)

Prepared 100mL Blocking buffer by adding 2g reagent grade VWR gelatin (VWR # 97062-618), to 5mL sterile 10X PBS, pH 7.39 to 80mL sterile DI water in a pre-sterilized 100mL media bottle (VWR # 10754-814).The gelatin solution was well mixed to dissolve and made to 100mL using sterile DI water.

4.3.9.2 BSA blocking buffer (1%)

Prepared 50mL 1% BSA blocking buffer by adding 0.5g bovine serum albumin (Alfa Aesar, Fraction V, 97%, Standard Grade, pH 7.0) obtained from VWR(item #AAJ64655-09) to 40mL sterilized DI water. Rock to mix until the BSA completely dissolves then made up to 50mL using sterilized DI water. Agitation of the BSA mixture will create a foam and will be unsuitable for use in this type of experimentation.

4.3.10. Preparation of secondary incubation buffer (6% BSA in PBS)

Prepared 50 mL Secondary incubation buffer by adding 3.0 g bovine serum albumin (Alfa Aesar, Fraction V, 97%, Standard Grade, pH 7.0) obtained from VWR(item #AAJ64655-09) to 5mL sterile 10X PBS, pH 7.39 to 40 mL with sterilized DI water in a 100mL pre-sterilized media bottle. The solution was well rocked until the BSA was completely dissolved and made up to 50 mL using sterile DI water. Smaller volumes of secondary incubation buffer was made and used when needed but was not stored for longer than 12 hours. This removed the need for using 0.02% sodium azide as a preservative. As the acute toxicity data is not listed on Alfa Aesar's SDS (5), the handler of BSA (VWR # AAJ64655-09) should wear appropriate PPE.

4.3.11. Preparation of Tris-Hydrochloride (1M)

A 100mL 1M sterile solution of Tris (hydroxymethyl) aminomethane was obtained from VWR (Cat # 97062-672). According to the certificate of analysis (COA)

for the Tris buffer, the solution contained no detectable traces of DNase, protease and Rnase and was pH adjusted to pH 8.0. A 1M Tris-Hydrochloride buffer at pH 7.5 is recommended for quenching the BS3 reaction. For our research the 1M Tris-HCL was pH adjusted to pH 7.50 using a 1N HCL solution obtained from VWR (Cat # BDH7202-7). The pH was adjusted by using 100uL 1N HCL solution with the pH measured using an Orion™ Star™ A211 pH Benchtop Meter Kit with ROSS Ultra Triode epoxy-body pH/ATC Electrode (VWR Cat # 89206-304). The pH adjusted solution was stored at 2-8°C.

4.3.12. Preparation of BS3 (bis (sulfosuccinimidyl) suberate)

Bis(sulfosuccinimidyl)suberate (BS3) manufactured by Toronto Research Chemicals (cat. # S777500) was obtained via VWR (cat. # 100568-726). As Toronto Research Chemicals could not provide any technical assistance as to the reconstitution of their BS3, the Pierce Biotechnology/ThermoScientific procedure for BS3 was used (6). To 70uL sterile DI water, added 4.0mg BS3 and mixed to fully dissolve the BS3 powder thereby obtaining a 100nM BS3 stock solution. For a 5nM BS3 working solution, a 1:20 dilution of BS3 stock solution in sterile DI water was made by adding 70uL of the 5nM BS3 solution to 1330uL sterile DI water. 100uL of the 5nM BS3 solution was added to each vial and incubated at room temperature for 30 minutes. According to the Pierce Biotechnology/ThermoScientific procedure the solution can be incubated on ice for up to 2 hours. To quench the BS3 reaction, the quenching reaction was accomplished by adding the 1M Tris-Hydrochloride solution to the 5nM BS3 solution to obtain a final concentration of 50nM Tris-Hydrochloride. Allowed the quenching reaction 15 minutes reaction time at room temperature.

4.3.13. Preparation of 3-aminopropyltriethoxysilane (APTES) solution (2%v/v)

The APTES solution (Pierce Biotechnology/ThermoScientific, cat. # 80370) was obtained from VWR (cat. # PI80370). The Pierce Biotechnology/ThermoScientific procedure for amino-silanization of a glass surface was used. A 2% v/v APTES solution was made by adding 2 mL APTES solution to 98 mL 91% isopropyl alcohol. This was performed in a well ventilate environment as a fume hood was not available. The pre-silanized 2mL glass vials with screw caps and septa top used in this research experiment was obtained from ThermoFisher (Cat # SCA-SV2-2) were rinsed for 30 seconds using the 2% (v/v) APTES solution. The caps were not treated as it is not used as a substrate. The glass vials were then rinsed three times (3x) using 91% isopropyl alcohol and allowed to air dry. The screw caps were inserted onto the glass vails and stored for future experimental use.

4.3.14. Preparation of *E.coli* 0157:H7 primary and secondary antibodies

The primary antibody used in this research was anti-*Escherichia coli* O157:H7 antibody from SeraCare (#01-95-90) and secondary antibody was biotin-labeled anti-*E.coli* 0157:H7 antibodies from SearCare (cat. #16-94-90) purchased via VWR (Radnor, PA, item # 01-95-90 & #16-95-90 resp.). The lyophilized 1mg primary and 0.5mg secondary antibody samples were transported at ambient temperature from SeraCare but stored at 2-8°C upon receiving. Both antibodies had a one year from the date of receipt expiration. The primary antibody (SeraCare, #01-65-90) was unlabeled goat affinity purified antibodies to *E.coli* 0157:H7 and the secondary antibody (SeraCare #16-95-90) was biotin labeled goat affinity purified antibodies to *E.coli* 0157:H7. The primary and secondary antibody SDS lists the toxicology risks as minor but proper PPE is advised for

the handler (7). To reconstitute the 1mg primary antibody sample, 1.0 mL of autoclaved sterilized 18.2 MΩ.cm deionized (DI) water (Elga Purelab Flex4, VWR) was added to the sample to yield a stock concentration of 1mg/mL (1000µg/mL) primary antibody.

The 0.5mg secondary biotin labeled was reconstituted using 0.5mL autoclaved sterilized 18.2 MΩ.cm analytical grade water to yield a stock concentration of 1mg/mL (1000µg/mL) secondary antibody. The Elga Purelab Flex4 DI water unit specification for bacterial endotoxin is <0.001 EU/ml (8). As outlined in the Seracare procedure for primary antibody working dilution, a 10µg/mL was prepared by using a 1:100 dilution of the 1000 µg/mL primary antibody stock solution in sterile DI water. Seracare recommended the biotinated secondary antibody to be reconstituted as a 10µg/mL working dilution. For this research we did not reconstitute the primary and secondary antibodies in blocking buffer (1% BSA), instead both primary and secondary antibodies were diluted using sterile DI water and used immediately after preparation. A second 40 µg/mL working solution of both the primary and secondary anti-*E. Coli* O157:H7 antibodies was prepared by 1:25 dilution of the 1000 µg/mL stock solution with DI water.

4.3.15. Preparation of Qdot™ 625 conjugated Streptavidin

Qdot™625 (Quantum Dot 625 registered to Invitrogen/ThermoScientific) conjugated streptavidin (cat. #A10196) was purchased from ThermoScientific (Waltham, MA). The 200 µL (1µM) Qdot sample was shipped from the vendor at ambient temperature but stored upon receipt at 2-8 °C. Prior to use the Qdot conjugate solution was microcentrifuged at 5,000 x g for 3 minutes. The supernatant was used in this experiment. The conjugate was diluted from the original 1 µM stock solution using 2 µL stock to 198

μ L (1:100) 6% BSA secondary incubation buffer yielding approximately 10 nM Qdot conjugate (9). The working conjugate dilution was obtained by performing a 1:5 dilution of the 10 nM Qdot conjugate using secondary incubation buffer to obtain approximately 2 nM Qdot conjugate solution.

4.3.16. Membrane Filtration method

Three 47mm Pall Laboratory Magnetic filter funnel assembly (VWR, cat. #28143-550) were cleaned using Decon Neutrad neutral cleaner (VWR, cat. #89234-804) and triple rinsed using DI water. The filter funnel cylinder and filter funnel base were placed into a Proper Chex-All® Heat-Sealable pouch (VWR, cat# 58753-258) and autoclave sterilized at 121°C for 30 minutes (Tattnauer 3870EA). A 3-place Pall Laboratory filter funnel manifold (VWR, cat. # 28145-349) was connected to a vacuum flask (VWR, Cat #10545-862) and to a vacuum (Welch, model #20196-01) pump shown in fig. 9. The sterilized filter funnel assembly was attached to the filter manifold, and using a heat sterilized forceps, a 0.45 μ m gridded filter membrane (Sartorius, NY, cat. # 114H6Z-47-SF) was placed onto the filter funnel base with the filter cylinder magnetically attached to the base. The sample was filtered through the membrane filter, as outlined in with the inner surfaces of the filter cylinder rinsed with 30mL PBS and vacuumed. The membrane filter was then transferred to a TSA plate and incubated at 35 \pm 0.5°C for 18-24 hours.

4.3.17. Fluorescence detection equipment materials

TXRED Emission Filter CWL=630nm BW=69nm (Thorlabs Inc Newton New Jersey, cat. #MF630-69)

- i. Plano-convex Focal Lens $\text{\O}1/2''$ $f=15.0\text{mm}$ (Thorlabs Inc.,cat. #LA1540-MIL)

- ii. Cage Assembly Rod, 4" Long, Ø6 mm, 4 Pack (Thorlabs Inc.,Cat. #ER4-P4)
- iii. SM1-Threaded 30 mm Cage Plate, 0.35" Thick, 2 Retaining Rings, M4 Tap
(Thorlabs Inc. cat.# CP02/M)
- iv. SM05-Threaded 30 mm Cage Plate, 0.35" Thick, Two Retaining Rings, M4
Tap (Thorlabs Inc. cat.# CP11/M)
- v. SM1 (1.035"-40) Coupler, External Threads, 0.5" Long (Thorlabs Inc. cat.#
SM1T2)
- vi. T-Cube LED Driver, 1200 mA Max Drive Current (Thorlabs Inc. cat.#
LEDD1B)
- vii. 15 V, 2.4 A Power Supply Unit for One K-Cube (Thorlabs Inc. cat.# KPS101)
- viii. VEP36 US Adapter Plug (Thorlabs Inc. cat.# ADAPTER4 US)
- ix. 340 nm, 53 mW (Min) Mounted LED, 700 mA (Thorlabs Inc. cat.# M340L4)
- x. SM1-Threaded 30 mm Cage Plate, 0.50" Thick, 2 Retaining Rings, 8-32 Tap
(Thorlabs Inc., cat. #CP02T/M)

The fluorescence equipment is constructed with the TXRED Emission Filter located directly below the sample vial, and the Plano-convex focal lens located below the TXRED emission filter which was mounted on the adaptor fitted onto the iPhone® 6S camera, fig. 10. The iPhone® 6S adaptor, fig.11, was made using white UHMW plastic, painted black.

4.3.18. Fluorescence Intensity Detection Software

ImageJ software (created by National Institutes of Health) version 1.51s was used in this research for ascertaining fluorescence intensity. The sample photographs taken for fluorescence analysis was opened using the ImageJ software. Using the “Oval” selection

of the area being analyzed, then “Clear Outside” was selected from the "Edit" function to remove extraneous noise from the photograph. The “Type” selection was accessed via the “Image” function, thereafter “8-bit Color” processing selected changing the picture to a format recognizable by ImageJ for “Threshold” adjustment. “Analyze particles” was selected from the “Analyze” function highlighting the fluorescing particles as shown in fig.12. Three background non-fluorescent area’s on the image were compared to the fluorescing particles and the ImageJ generated comparison was input into an Excel spreadsheet created by McCloy, et al. (10) to obtain the Corrected Total Cell Fluorescence (CTCF). CTCF was calculated using the formular proposed by McCloy, et al. (10), $CTCF = \text{Integrated density} - (\text{area of selected fluorescent cell} \times \text{mean fluorescence of the 3 selected background readings})$. The mean CTCF was calculated and plotted against corresponding enumerated CFU/0.1mL or Log CFU/0.1mL.

4.4 Results

The McFarland Standard latex equitant #0.5 solution yielded an average 0.17 absorbance units with the *E.coli* 0157:H7 stock solution yielding 0.15 absorbance units with a calculated estimate of 1.1×10^9 CFU/mL *E.coli* 0157:H7. Using the alternative method for bacterial culture suspensions, yielded 1.39×10^7 CFU/mL *E.coli* 0157:H7 and 5.60×10^6 CFU/mL *E.aerogenes* working stock suspensions.

For additional test samples duplicate 100 μ L, 50 μ L and 20 μ L aliquots was taken from *E.coli* 0157:H7 dilution A and labeled as EC01, EC02, EC03, respectively. One set of the duplicate EC01, EC02, and EC03 samples were analyzed using the membrane filtration method whilst the duplicate test sample was analyzed for fluorescence intensity. For consistency with the experiment outlined in fig. 13, aliquots other than 100 μ L, sterile

PBS was added to make the total sample volume 100 μ L. As shown in table 2, *E.coli* 0157:H7 CFU/0.1mL were converted to *E.coli* 0157:H7 log (CFU/0.1mL) and using Minitab[®]16 the *E.coli* 0157:H7 log counts were plotted against corresponding CTCF values yielding a R² value of 97.1%. The dose response fitted plot for CTCF-fluorescent intensity = -31 + 622 (*E.coli* 0157:H7 Log CFU/0.1mL). Sample EC06 revealed a standardized residual of -2.03.

E.coli 0157:H7 counts and respective CTCF values shown in table 3 were analyzed using Minitab[®]16, yielding R² = 97.1% and a fitted line plot for CTCT-fluorescence intensity = 211 + 43 (*E.coli* 0157:H7 CFU/0.1mL). Controls labeled as EC20 and tested in duplicate were run using 100 μ L sterile 1% PBS in place of *E.coli* 0157:H7 test suspensions, yielded <1 CFU/0.1mL *E.coli* 0157:H7 and corresponding 199.75 and 202.797 CTCF values. Using Minitab 16, the control generated a mean CFCF of 205.46 and $\sigma = 7.41$.

As outlined in table 4, *E.aerogenes* CFU/0.1mL were compared to respective CTCF values and generated R² = 23.6% with Minitab[®]16.

4.5 Discussion

The use of McFarland standard solutions have been a useful technique for the preparation of bacterial suspensions and when a 1 cm light path set to 625nm, a comparable turbidity to that of McFarland latex standard #0.5 at an absorbance of 0.08-0.10 ABS would yield a bacterial suspension of 1.5 x 10⁸ CFU/mL (11,12). In this experiment a 2.54cm light path was used, and to compensate for the difference, the turbidity of the working *E.coli* 0157:H7 stock solution was adjusted to match the absorbance comparable to that of the McFarland latex standard #0.5 solution yielded a

working *E.coli* 0157:H7 stock solution of 1.1×10^9 CFU/mL. Even though the McFarland Standard method for preparing bacterial suspensions provides an estimated CFU/mL, it is time consuming to obtain a comparable turbidity to that of the McFarland latex standard # 0.5 solution. As was found during this experiment, in adjusting to match the turbidity of the McFarland latex standard #0.5 , spillages occurred which not only extended the process but working with BSL-2 pathogens spillages have the potential to increased risks and is not a recommended method when using BSL-2 and above pathogens. For *E.coli* and *E.aerogenes*, a single isolated colony from a Tryptic Soy Agar (TSA) plate incubated at $35 \pm 0.5^\circ\text{C}$ for 18-24 hour was inoculated into 10mL PBS and vortexed at 2200 rpm for 20 seconds yielded approximately 1.0×10^7 CFU/mL.

Qdot 625™ Streptavidin Conjugate, fig. 14, which as an emission maxima of approximately 625 nm, has 5 to 10 streptavidin's per Qdot® nanocrystal and with an extinction coefficient of $14,700,00 \text{ cm}^{-1} \text{ M}^{-1}$ at 350 nm the highest extinction coefficient amongst the Qdot conjugate family (13,14). Even though the LED UV light used in this experiment was 340 nm with a bandwidth of 11 nm, according to ThermoScientific technical support the lower UV wavelength would not be significant in the outcome. Using the ThermoScientific Fluorescence SpectraViewer for customizing Qdot 625™ also confirmed that using 340 nm wavelength UV LED as the excitation source would not diminish the fluorescence result (15).

In our initial investigation, the 340 nm LED was located directly above the glass vial with the $2.22 \mu\text{W}/\text{mm}^2$ irradiance passing straight through the TXRED emission filter. Even though the TXRED emission filter specification for 330-350 nm allows an average of only 0.037 % transmission through the TXRED emission filter, the extraneous

irradiance overwhelmed the detection of fluorescence (16). As the extraneous excitation light is reduced by the microscope principle of perpendicular detection of emission light, the UV light source was relocated 90° to the TXRED emission filter, fig. 15, which significantly reduced extraneous irradiance (17,18). As the 340 nm LED as shown in fig. 16, was controlled by LED driver, power to the LED was consistent throughout the experiment. As only the bottom 25 % of the 2mL sample vial was used in this research, observations of light reflection in photographic images were noted, but these were removed using the ImageJ software leaving only the known test area for fluorescence intensity analysis.

Initially a 2% gelatin blocking solution described in a procedure by Zhu, et.al (19) was used to reduce non-specific binding (17) on the antibody binding sites but we found that the 2% gelatin created a significant amount of background (20) “noise” in the photographed sample images. Also 2% gelatin in this experiment solidified at solution temperature <25°C and in a laboratory maintained at 20°C, the aqueous 2% gelatin solution had to be maintained in a water bath. 1% Bovine Serum Albumin (BSA) was shown to be an effective blocking agent by Du, et al. (21), and was used as the replacement for 2 % gelatin as the blocking agent in this research.

Initially we used the primary and secondary antibodies at a 10µg/mL concentration as recommended by SeraCare, 100µL aliquots of each antibody and 100µL of a 2 nM solution of Qdot™ 625 Steptavidin conjugate but found lower than expected fluorescence at spiked *E.coli* 0157:H7 concentrations in the 1×10^4 - 1×10^6 CFU/0.1mL range. As was eluded to by Yang and Li (22) in their work with *E.coli* 0157:H7 and

Salmonella typhimurium , we used 200 μ L of 40 μ g/mL of the primary and secondary antibodies and 200 μ L of 10 nM Qdot™ 625 Streptavidin conjugate in this research.

Using the fluorescence processing methodology outlined in fig. 17, the dose response of spiked *E.coli* 0157:H7 (log CFU/0.1mL) compared to CTCF values and $R^2 = 97.8\%$, fig. 18, shows a strong linear relationship between the logarithm of *E.coli* 0157:H7 spiked concentrations to that of corrected total cell fluorescence (CTCF), fig. 19. In this data set, sample #6 having a CTCF of 1707.780 was considered as an outlier in and in evaluating that background fluorescence data for the data points for sample #5 and sample #7, shows the outlier having a background mean fluorescence intensity twice that of data observation #5 and #7 leading to a CTCF residual of -407.6. A possible reason for the error stemmed from the three background control regions selected for CTCF calculation having background “noise” that was not adequately filtered out with the ImageJ fluorescence analysis program.

To examine the minimum detection limit of fluorescence intensity to that of *E.coli* 0157:H7 detection, a dose response of *E.coli* 0157:H7 CFU/0.1mL to CTFT ,fig. 20, yielded a $R^2= 97.1\%$ with a low P value, fig. 21, showing the model fitting the data. No unusual residual observations were noted showing the strong linear goodness-of-fit. The analysis of variance (ANOVA) in fig. 22, with a $P<0.001$ and $F >P$, we can reject the null-hypothesis and conclude that model of *E.coli* 0157:H7 CFU/0.1mL and CTCF, provides a better fit than the regression model, fig. 23 (23). For the control blank, $1 \pm \sigma$ was shown to be 205.46 ± 4.28 , and with *E.coli* 0157:H7 at 1 CFU/0.1mL generating a CTCF of 255.4 is greater than 3 sigma units above control blank CTCF.

In this research, *E.aerogenes* was used to show method specificity towards the negative control. *E.aerogenes*, a coliform shows positive traits for coliforms but does not show *E.coli* biochemical traits and is commonly used in drinking water method analysis. *E.aerogenes* showing a CTCF mean of 188.30 was lower than 3σ below the control blank CTCF of 192.62. In fig. 22, $P > 0.001$ and $F < P$, suggests that we accept the null hypothesis as there is no relationship between *E.aerogenes* concentrations and CTCF.

4.6 Conclusion

The objective of this project was to meet the WHO ASSURED characteristics for point of use diagnostic tools i.e. Affordable: <\$10/test, our model yielded a total cost of \$11.86 per analyzed sample excluding the hardware cost. A one time equipment purchase for UV modular equipment- \$1100.00 influenced the total cost per analyzed sample but with the UV LED having >3000 hour lifetime enabling 90,000 tests at 1-2 minutes fluorescence reading time per test works out to \$0.012 per test thus the total cost per analyzed test is \$11.88. The major negative influence to the cost per sample analyzed stemmed from the use of Qdot® 625 which retails at \$568.00 for 200 μ L (excluding shipping and taxes). For Sensitivity/Selectivity: *E.coli* 0157:H7 minimum detection limit of 1 CFU/0.1mL was achieved with *E.aerogenes* proving method selectivity/specificity. The User-friendly aspect: <1 day training for an analyst with no prior knowledge of methodology was achieved with the model being Rapid and Robust-the cell labeling preparation total time was 2.5-3 hours, but took < 5 minutes for a *E.coli* 0157:H7 confirmation. Equipment Free: onsite analysis was proven and no logistical requirements were needed and Deliverable achieved by using the NIH ImageJ open source free software and cell phone. Our objective for affordability was set at < \$10/test but our

proposed model exceeded the affordability aspiration by \$1.88/test but the model was successful in obtaining an *E.coli* 0157:H7 analysis at the EPA minimum detection limit for potable water in <5 minutes.

4.7 References

1. Epidemiology of *Escherichia coli* O157:H7 Outbreaks, United States, 1982–2002
2. Stanwellsmith R. J.A. Contruvo, A. Dufour, G. Rees, J. Bartram, R. Carr, D.O. Cliver, and G.F. Craun, R. Fayer and V.P.J. Gannon, editors. Waterborne zoonoses: Identification, causes and control. IWA publishing (2004).
3. Wu G, Zaman MH. Low-cost tools for diagnosing and monitoring HIV infection in low-resource settings. *World Health Organization. Bulletin of the World Health Organization*. 2012;90(12):914F
4. Microbiologics.com.
www.microbiologics.com/core/media/media.nl?id=920&c=915960&h=4f09c578562b0226e1dd&_xt=.pdf. Published on 13 January 2013. Accessed 03 April 2017.
5. Safety Data Sheet. Alfa.com.
<https://www.alfa.com/en/content/msds/USA/J64655.pdf>. Accessed on 20 October 2017.
6. User Guide: DSS and BS3 Crosslinkers. ThermoScientific.com.
<https://www.thermofisher.com/order/catalog/product/21580>. Accessed on 04 August 2017.
7. Safety Data Sheet. Seracare.com.
<https://www.seracare.com/contentassets/173aaa557a5c42878b61641f980ee019/sds-101443807.pdf>. Accessed on 29 August 2017.
8. ElgaLabWater.com.
<https://www.elgalabwater.com/products/purelab-flex-3-4>. Accessed 20 August 2017

9. Qdot® Streptavidin Conjugates. ThermoScientific.com.
<https://tools.thermofisher.com/content/sfs/manuals/mp19000.pdf>. Published on 12 September 2007. Accessed on 10 October 2017.
10. McCloy RA, Rogers S, Caldon CE, Lorca T, Castro A, Burgess A. Partial inhibition of Cdk1 in G(2) phase overrides the SAC and decouples mitotic events. *CELL CYCLE*. 2014; 13(9):1400-1412.
11. McFarland Latex Standards, Hardy Diagnostics,
https://catalog.hardydiagnostics.com/cp_prod/Content/hugo/McFarlandStds.htm ,
Accessed 27 July 2017.
12. Zapata A, Ramirez-Arcos S. A comparative study of McFarland turbidity standards and the densimat photometer to determine bacterial cell density. *Current Microbiology*. 2015; 70(6):907-909.
13. Avidin, NeutrAvidin and Streptavidin Conjugates.
<https://www.thermofisher.com/us/en/home/references/molecular-probes-the-handbook/antibodies-avidins-lectins-and-related-products/avidin-streptavidin-neutravidin-and-captavidin-biotin-binding-proteins-and-affinity-matrices.html>.
Accessed on 12 August 2017.
14. Extinction Coefficients of Qdot Nanocrystal Streptavidin Conjugates at Ultraviolet and Visible Wavelengths.
<https://www.thermofisher.com/us/en/home/references/molecular-probes-the-handbook/tables/extinction-coefficients-of-qdot-streptavidin-conjugates-at-common-wavelengths.html>. Accessed on 12 August 2017.

15. Fluorescence SpectraViewer. <https://www.thermofisher.com/us/en/home/life-science/cell-analysis/labeling-chemistry/fluorescence-spectraviewer.html?SID=srch-svtool&UID=QD655SA>. Accessed 15 November 2017.
16. Fluorescence Imaging Filters.
https://www.thorlabs.com/newgrouppage9.cfm?objectgroup_id=2990&pn=MDF-TXRED#2994. Accessed 18 September 2017
17. Zhu HY, Sikora U, Ozcan A. Quantum dot enabled detection of *Escherichia coli* using a cell-phone. *ANALYST*. 2012; 137(11):2541-2544.
18. Mondal PP, Diaspro A. Simultaneous multilayer scanning and detection for multiphoton fluorescence microscopy. *SCIENTIFIC REPORTS*. 2011; 1(1):149.
19. Zhu HY, Sikora U, Ozcan A. Quantum dot enabled detection of *Escherichia coli* using a cell-phone. *Analyst*. 2012;137(11):2541-2544.
20. Immobilization Principles – Selecting the Surface.
<http://csmedia2.corning.com/LifeSciences/media/pdf/elisa1.pdf>. Published July 2001.
Accessed 23 November 2017.
21. Gaimei Du, Maojun Liu, Yuan Gan, Yanna Wei, Yuzi Wu, Guoqing Shao. Study on screening of optimal blocking buffer and sample diluent for ELISA. *Agricultural Science & Technology*. 2013; 14(6):816.
22. Yang LJ, Li YB. Simultaneous detection of *Escherichia coli* O157: H7 and *Salmonella typhimurium* using quantum dots as fluorescence labels. *ANALYST*. 2006; 131(3):394-401.
23. Pardoe I., Inference for the Population Intercept and Slope. Penn State University.
<https://onlinecourses.science.psu.edu/stat501/node/261>. Accessed 31 December 2017.

Chapter 5 Future Directions

5.1 Concentrating the test sample

The EPA approved method for drinking water total coliform and *E.coli* analysis using membrane filtration is to use 100mL sample aliquots, filtered through a 0.45µm membrane filter with the membrane filter transferred to a suitable agar plate such as mEndo agar and Nutrient agar w/MUG and incubated at 35±0.5°C for 24h and 4h respectively. In this experiment, duplicate 0.1mL spiked *E.coli* 0157:H7 samples at dilutions ranging between 0 Log and 3 Log were added to 99.9mL sterile PBS, mixed and filtered as outlined in the membrane filtration technique. After filtering the spiked 100mL sample, the membrane filter was scrapped using the flat sharp edge of cardstock paper. The scrapping on the cardstock was rinsed using 100µL sterile PBS and analysed using the fluorescent technique outlined in this research. The scrapped membrane filter was placed on TSA plates and incubated at 35±0.5°C for 24h. The duplicate spike sample membrane filter was scrapped using the cardstock paper and rinsed using 100µL sterile PBS and spread onto TSA plates with the scrapped membrane filter transferred onto TSA plates. Both the membrane filter and spread plate were incubated at 35±0.5°C for 24h and then read. The membrane filters showed appropriate growth for the respective serial dilutions but all spread plates containing the concentrated 100µL spiked aliquot failed to grow. The fluorescence intensity for each spiked aliquot tested was consistent with the baseline CTCF of unspiked control samples suggesting that scraping the bacteria off the membrane filter did not remove the bacteria off the membrane filter. Laminated cardstock paper was also tried but this failed as well proving that scraping bacteria off a membrane filter for concentration purposes is not effective. For future research to obtain

EPA method approval, centrifuging the 100mL sample with the concentrated pellet dissolved in 100 μ L sterile PBS for fluorescence analysis. Future considerations also include the use of 25mm 0.45 μ polyvinylidene difluoride (PVDF) membrane filter for concentrating a 100mL water sample then adding the conjugate antibody/fluorophore onto the PVDF membrane.

5.1 Method Simplification

Diluting the anti-*E.coli* 0157:H7 antibodies and Streptavidin conjugate requires operator skill, thus for field-based use, simplification of the procedure to include pre-diluted reagents for drinking water analysis would be advantageous. In this research, appropriate dilutions for the antibodies and Streptavidin conjugate have been formulated to obtain a minimum 1CFU *E.coli* 0157:H7 meeting the intent of the EPA/FDA total coliform rule.

5.3 Analytical Software

The open source and freely accessible ImageJ software used in the research has been shown to be a useful tool for fluorescence intensity/CTCF analysis but at the time of this research a comparable mobile app for ImageJ was not available for the IOS system. A mobile app for directly analyzing pictures taken during fluorescence intensity analysis will add to the rapid nature of this proposed method, unfortunately due to time constraints this was not a focus in this research.

Tables

Method Origin	Method #	Method Type	Method Title	Incubation time
Standard Methods for the Examination of Water and Wastewater, 22nd Edition	SM 9221 F	Lactose Fermentation	<i>E. coli</i> Procedure Using Florogenic Substrate	24h
Standard Methods for the Examination of Water and Wastewater, 22nd Edition	SM 9222 G	MF Partition	Other <i>E. coli</i> Procedures (PROPOSED)	28h
US Environmental Protection Agency (EPA)	EPA 1604	Membrane filtration	Total Coliforms and <i>E. coli</i> in Water by Membrane Filtration Using a Simultaneous Detection Technique (MI Medium)	24h
Hach Company	<u>m-ColiBlue24® Test</u>	Membrane filtration	Membrane Filtration Method m-ColiBlue24® Broth	24h
EMD Millipore	<u>Chromocult® Coliform Agar (CCA)</u>	Membrane filtration	Chromocult® Coliform Agar Presence/Absence Membrane Filter Test Method for Detection and Identification of Coliform Bacteria and <i>E. coli</i> for Finished Waters	24h
Standard Methods for the Examination of Water and Wastewater, 22nd Edition	SM 9223 B	Membrane filtration	Standard total coliform membrane filter procedure	28h
Charm Sciences	<u>Charm E*Colite® Test</u>	Enzyme substrate	Charm E*Colite™ Presence/Absence Test for Detection and Identification of Coliform Bacteria and <i>E. coli</i> in Drinking Water	48h
Idexx	<u>Colilert-18</u>	Enzyme substrate	Simultaneously detects both total coliforms and <i>E. coli</i> in water	18h
Hach Company	<u>Modified Colitag™ P/A Test</u>	Enzyme substrate	Modified Colitag™ Test Method for the Simultaneous Detection of <i>E. coli</i> and other Total Coliforms in water	24h
Veolia Water Solutions & Technologie	<u>TECTA™ B16</u>	Enzyme substrate	Tecta™ EC/TC medium and the Tecta™ Instrument: A Presence/Absence Method for Simultaneous Detection of Total Coliforms and <i>E. coli</i> in Drinking Water	2-18h

Table 1 EPA approved drinking water methods for detection of *E. coli*. Modified from EPA Analytical Methods Approved for Compliance Monitoring under the Revised Total Coliform Rule (2)

Sample #	<i>E.coli</i> 0157:H7 (CFU/0.1mL)	<i>E.coli</i> 0157:H7 Log (CFU/0.1mL)	Correct Total Cell Fluorescence (CTCF)
1	1.4x10 ⁶	6.15	4085.941
2	7.0x10 ⁵	5.85	3559.464
3	2.8x10 ⁵	5.45	3334.820
4	1.4x10 ⁴	4.15	2473.580
5	7.0x10 ³	3.85	2208.140
6	2.8x10 ³	3.45	1707.780
7	139	2.14	1249.810
8	15	1.18	800.801
9	11	1.04	589.241
10	1	0.00	198.28

Table 2 *E.coli* 0157:H7 log(CFU/0.1mL) and corrected total cell fluorescence (CTCF)

Sample #	<i>E.coli</i> 0157:H7 (CFU/0.1mL)	Correct Total Cell Fluorescence (CTCF)
11	37	1700.100
12	23	1373.900
13	21	1250.700
14	19	957.600
15	16	810.900
16	7	496.400
17	7	487.300
18	1	255.400
19	0	213.830
20 Control	0	202.797

Table 3 *E.coli* 0157:H7 (CFU/0.1mL) and corrected total cell fluorescence (CTCF)

Sample #	<i>E.aerogenes</i> (CFU/0.1mL)	Correct Total Cell Fluorescence (CTCF)
21	56	188.300
22	28	193.000
23	11	181.000

Table 4 *E.aerogenes* (CFU/0.1mL) and corrected total cell fluorescence (CTCF)

Figures

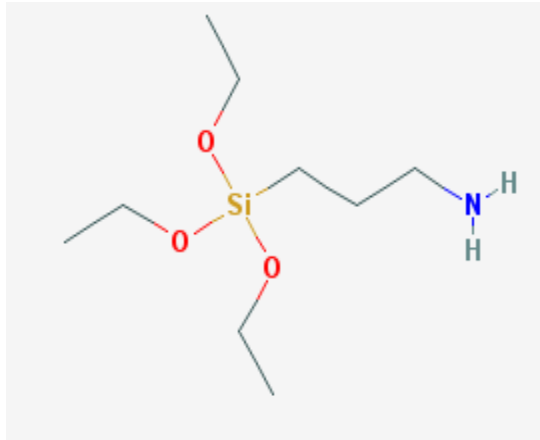

Figure 1 Structure of 3-(aminopropyl)triethoxysilane (National Center for Biotechnology Information. PubChem Compound Database; CID=13521, <https://pubchem.ncbi.nlm.nih.gov/compound/13521>)

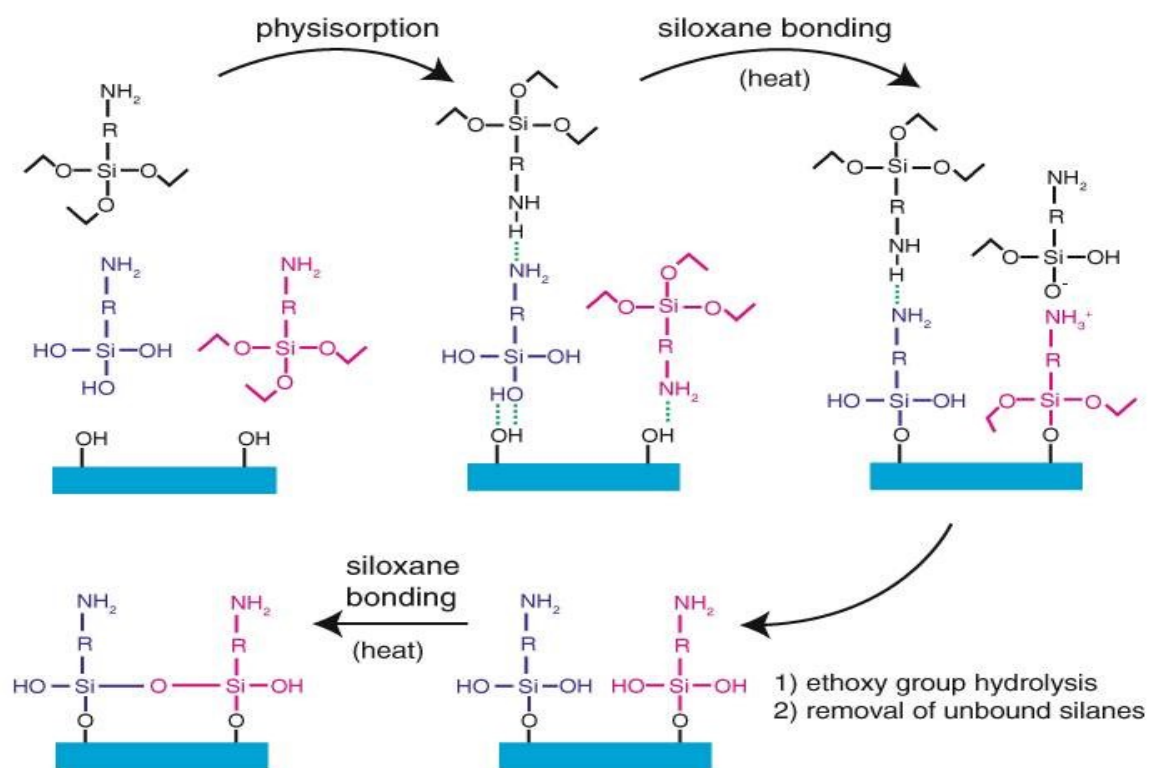

Figure 2 3-Aminopropyltriethoxysilane (APTES) functionalization of glass substrate. (Used with publisher permission # 4310540031988. Nicholas MP, Rao L, Gennerich A. Covalent immobilization of microtubules on glass surfaces for molecular motor force measurements and other single-molecule assays. *Methods in molecular biology* (Clifton, N.J.). 2014;1136:137)

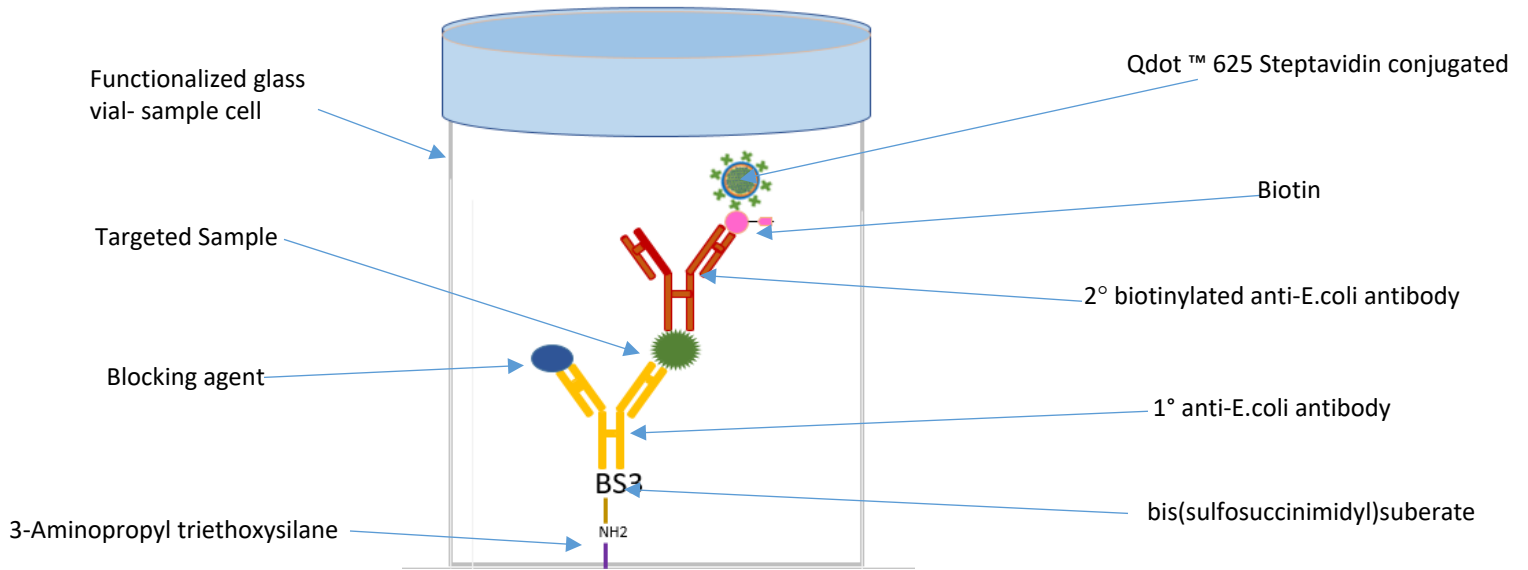

Figure 3 The design of the antibody-surface immobilization and antibody- sample-conjugate assay (modified from Francis JE, Mason D, Levy R. Evaluation of quantum dot conjugated antibodies for immunofluorescent labelling of cellular targets. BEILSTEIN JOURNAL OF NANOTECHNOLOGY. 2017;8(1):1238-1249 and Jung Y, Jeong JY, Chung BH. Recent advances in immobilization methods of antibodies on solid supports. ANALYST. 2008;133(6):697-70)

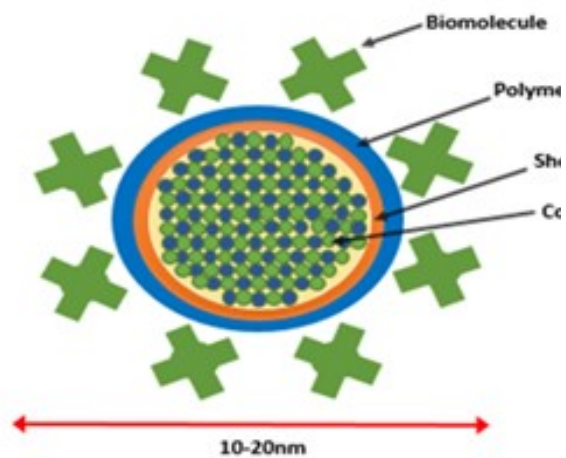

Figure 4 Structure of a Qdot Bioconjugate
 (modified from Held.P, Determination of Fluorescence Excitation and Emission Peaks for Qdot® Nanocrystals Using the Synergy™ 4 Multi-Mode Microplate Read, BioTek Instruments, Inc,2007)

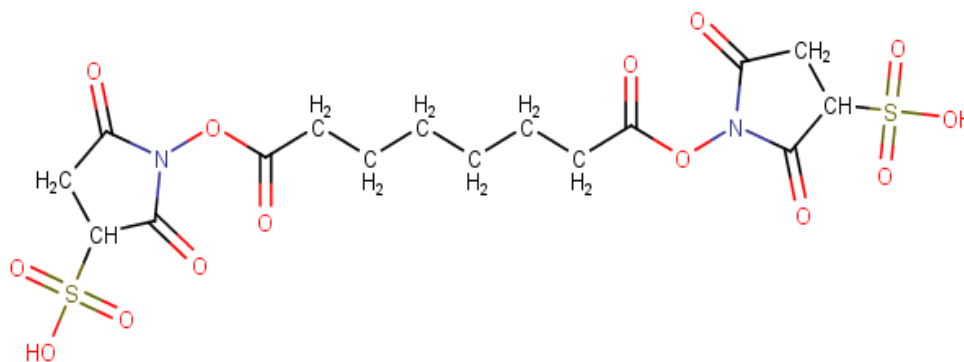

Figure 5 Structure of bis(sulfosuccinimidyl)suberate (National Center for Biotechnology Information. PubChem Compound Database; CID=123854, <https://pubchem.ncbi.nlm.nih.gov/compound/123854>)

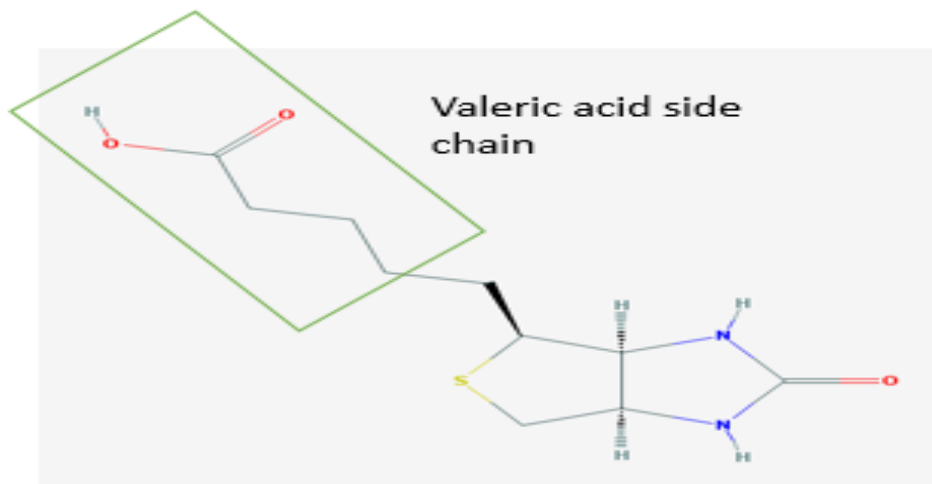

Figure 6 Structure of Biotin. (National Center for Biotechnology Information. PubChem CompoundDatabase; CID=171548, <https://pubchem.ncbi.nlm.nih.gov/compound/171548>)

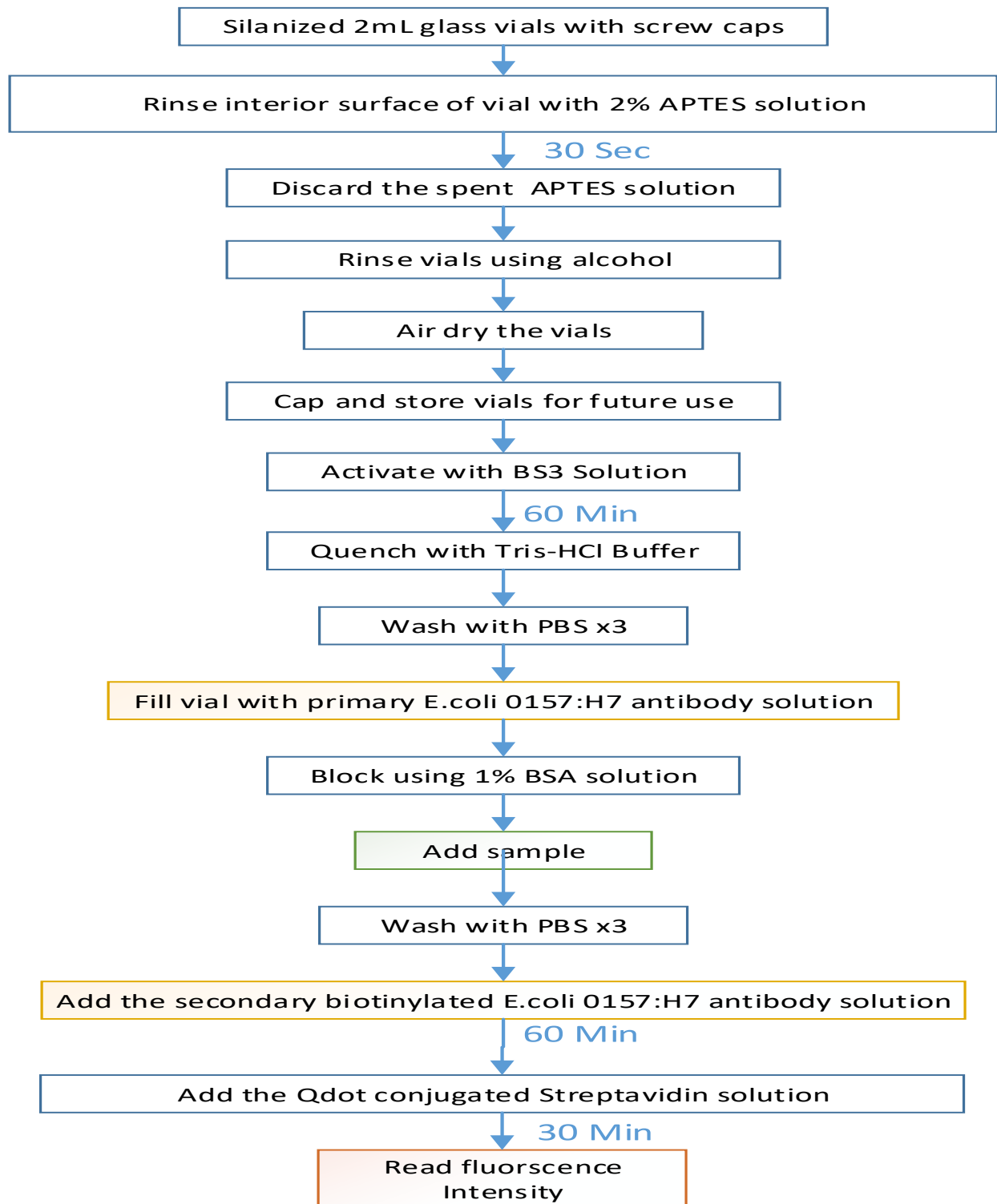

Figure 7 Bacteria fluorescence labeling flow chart (procedure modified from Invitrogen Qdot Conjugate Protocol Handbook, PN 90-0153, Rev 1.1 ; ThermoFisher Scientific User Guide: 3-Aminopropyltriethoxysilane and Zhu HY, Sikora U, Ozcan A. Quantum dot enabled detection of Escherichia coli using a cell-phone. Analyst. 2012;137(11):2541-2544)

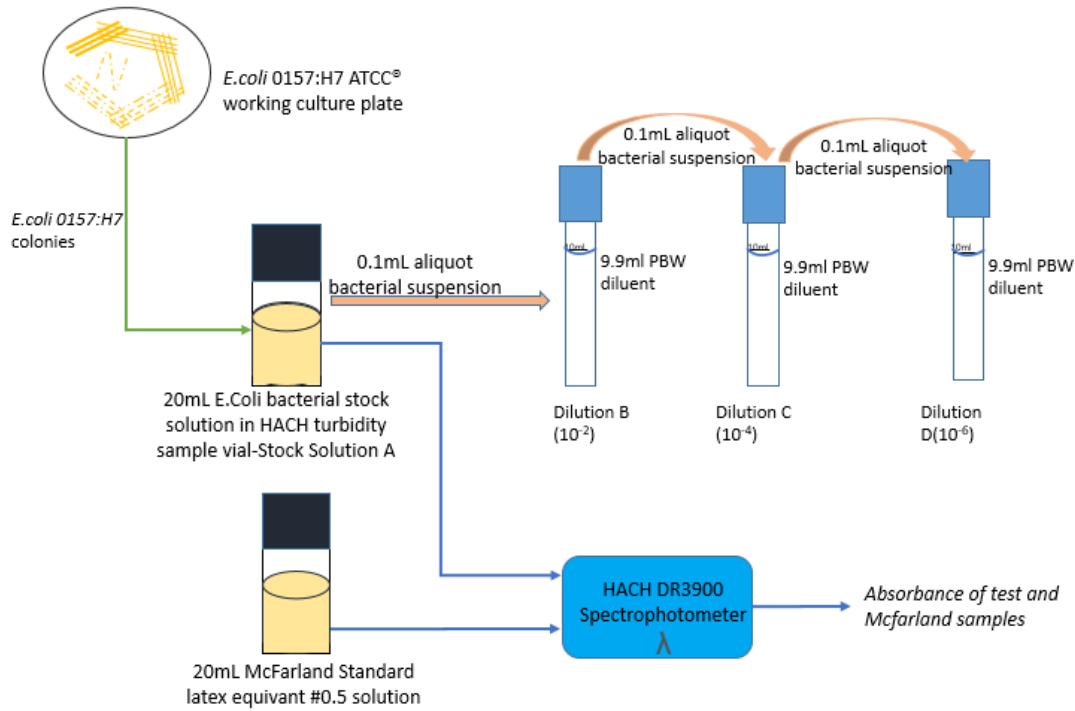

Figure 8 Working bacterial dilution suspension preparation using the McFarland Standard latex equivalent #0.5 solution



Figure 9 Typical Membrane filtration setup

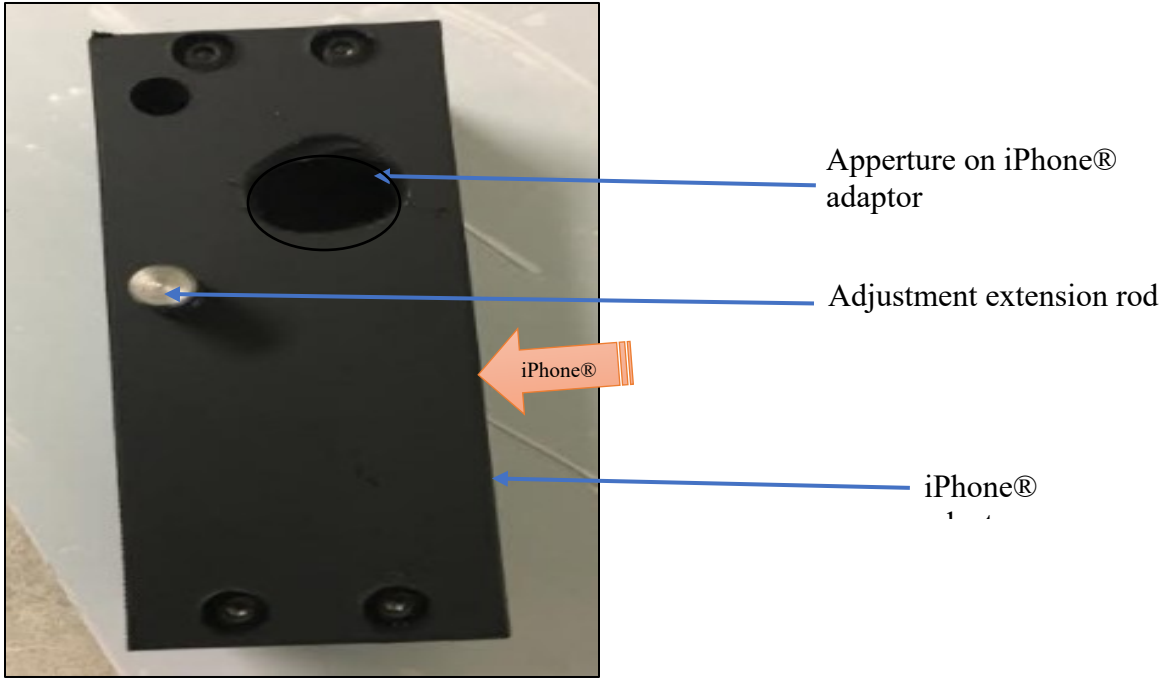

Figure 3 iPhone® 6S adaptor- top view (constructed by Steve Harris with design by Sathie Thayagan. iPhone®6S is owned by Apple Inc.)



Figure 4 iPhone® 6S adaptor- front view (constructed by Steve Harris with design by Sathie Thayagan. iPhone®6S is owned by Apple Inc.)

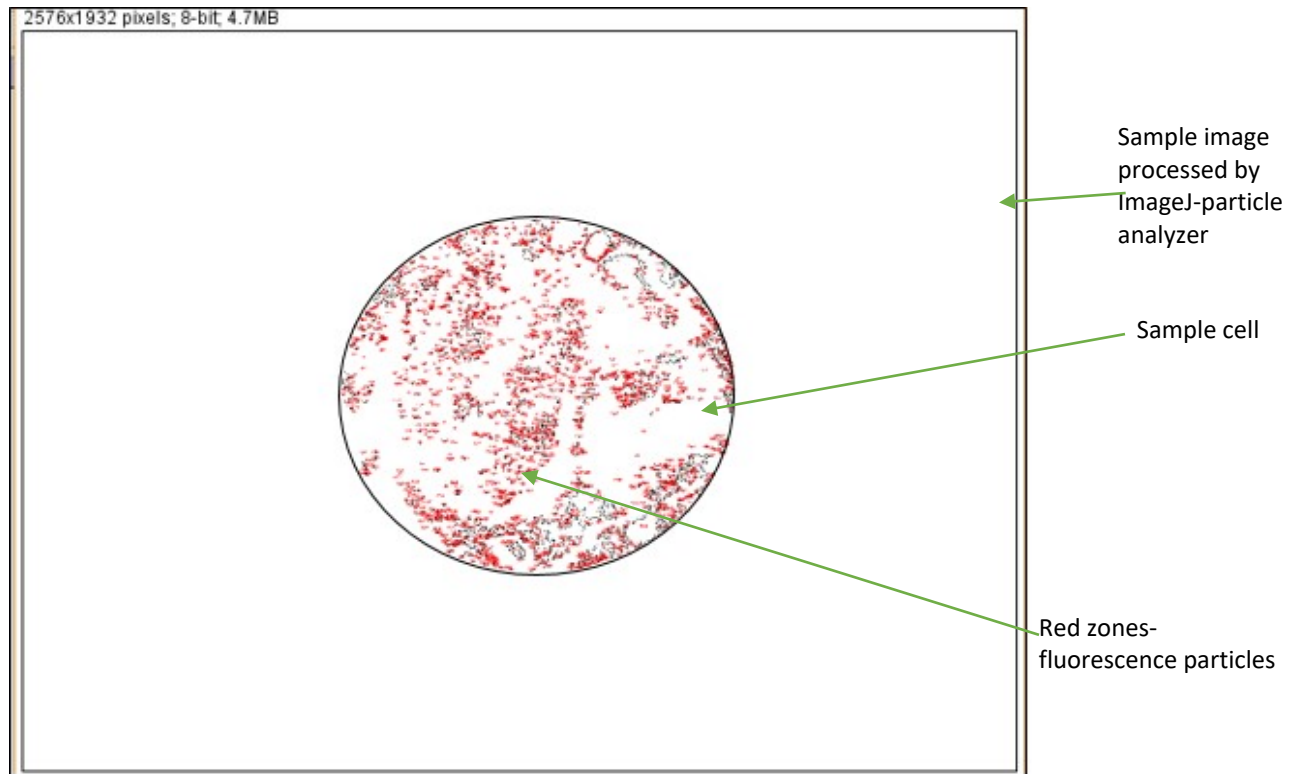

Figure 5 Typical sample fluorescence image-processed with ImageJ Particle Analyzer Software (NIH ImageJ ver. 1.51r 15)

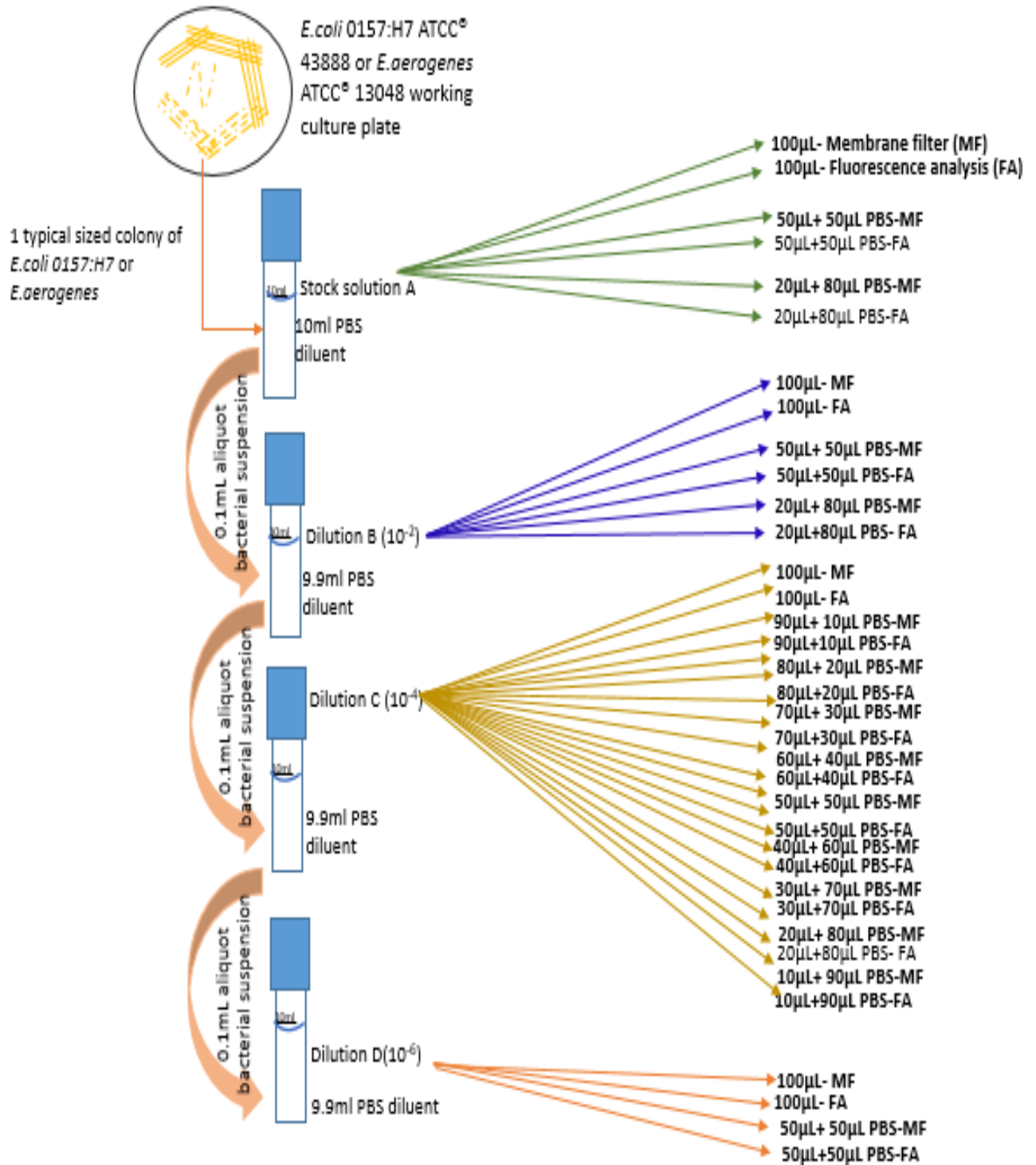

Figure 13 Serial dilution and test sample aliquot sampling plan

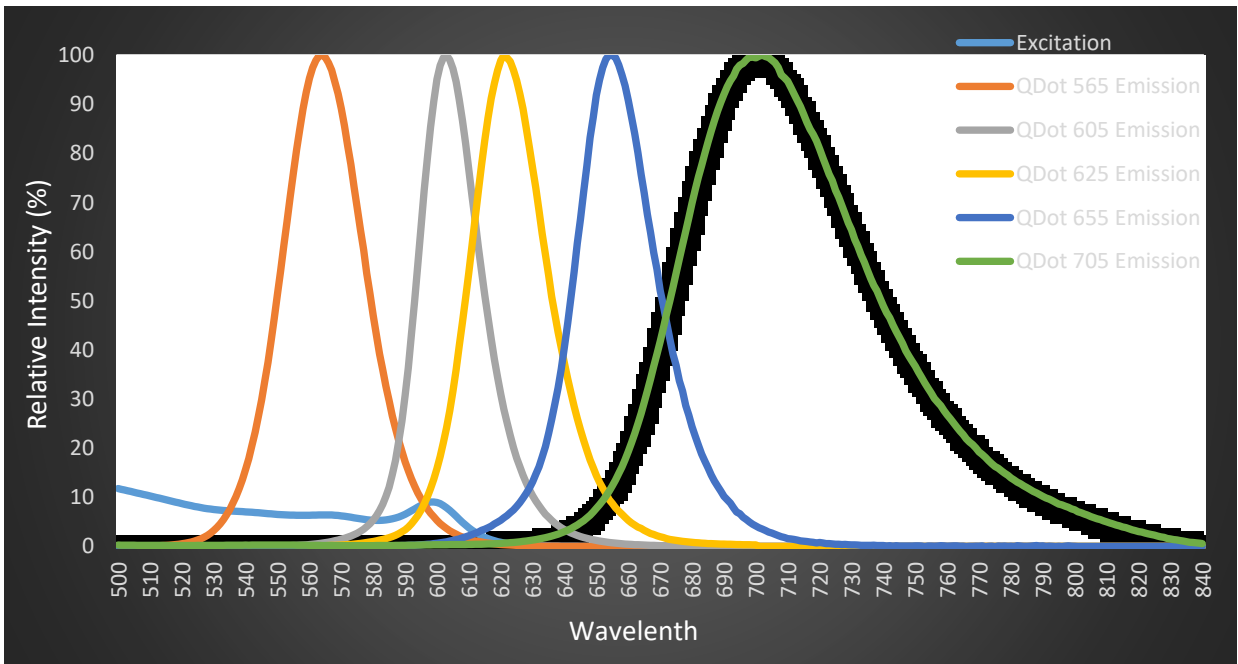

Figure 14 Excitation and emission spectra of five different QDot fluorophores. (Generated using ThermoFisher Scientific Fluorescence SpectraViewer)

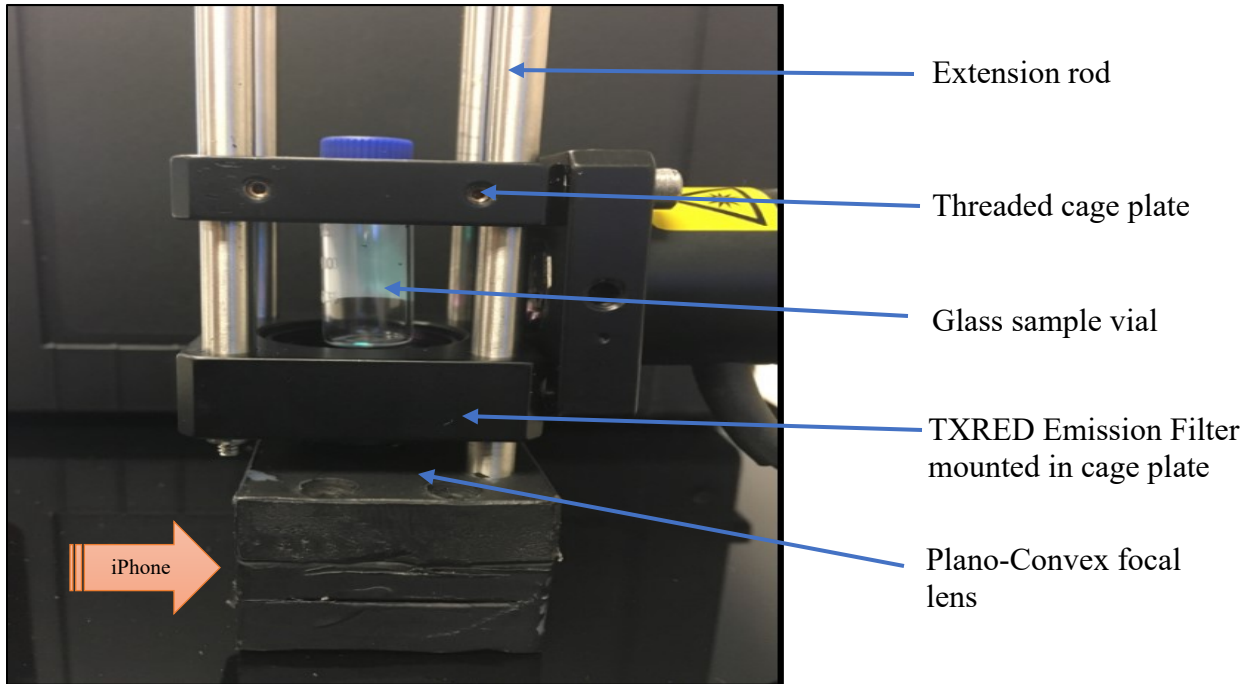

Figure 6 Fluorescence equipment showing sample vial, filters and lens (constructed by Steve Harris with design by Sathie Thayagan)

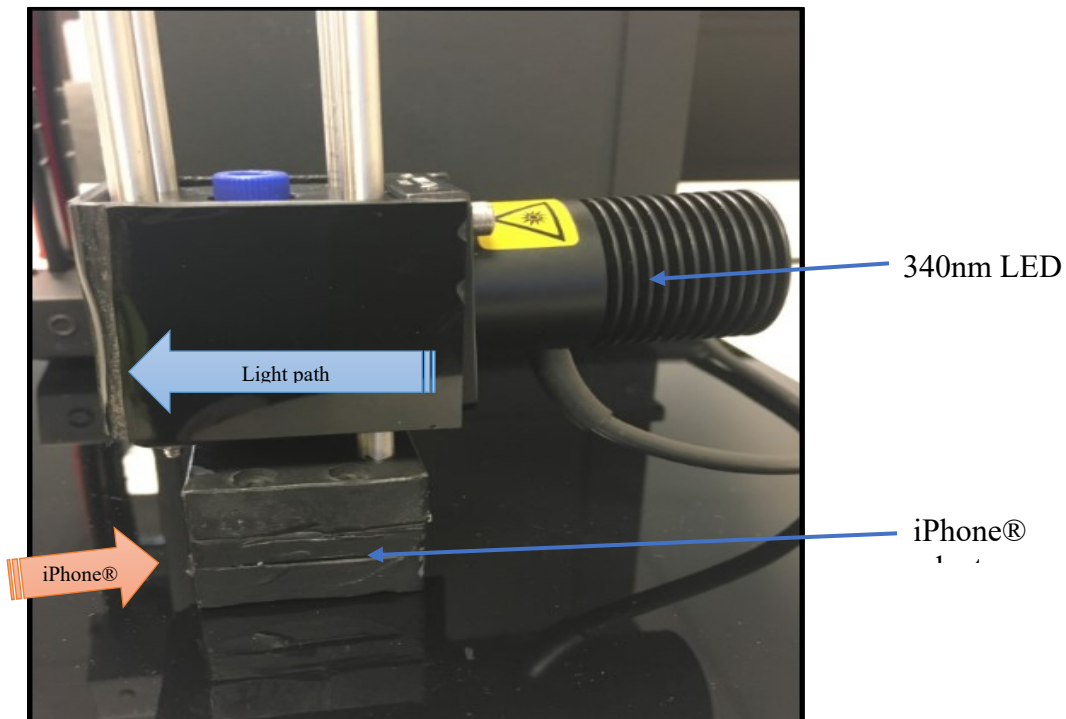

Figure 7 Fluorescence equipment with light cover mounted on iPhone® 6S adaptor (constructed by Steve Harris with design by Sathie Thayagan)

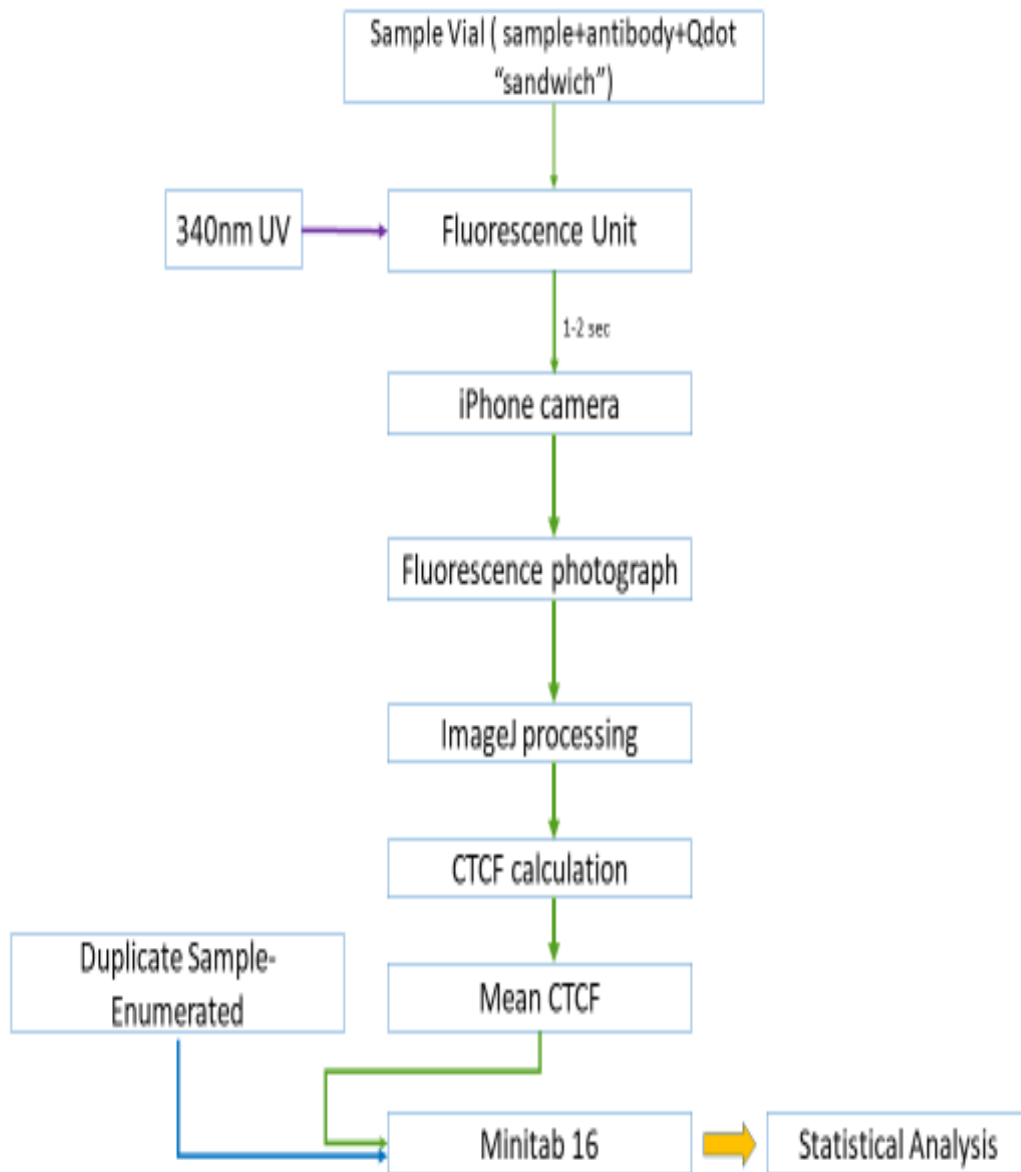

Figure 8 Bacteria fluorescence intensity processing flow chart

Descriptive Statistics: CTCF-Fluorescence Intensity

Variable	N	N*	Mean	SE Mean	StDev	Minimum	Q1	Median
CTCF-Fluorescence Intensity	10	0	2021	424	1340	198	748	1958

Variable	Q3	Maximum
CTCF-Fluorescence Intensity	3391	4086

Regression Analysis: CTCF-Fluorescence versus *E.coli* 0157:H7 Log (CFU/0.1mL)

The regression equation is

$$\text{CTCF-Fluorescence Intensity} = -31 + 622 (\text{E.coli 0157:H7 Log CFU/0.1mL})$$

Predictor	Coef	SE Coef	T	P
Constant	-30.6	128.5	-0.24	0.817
<i>E.coli</i> 0157:H7 Log CFU/0.1mL	622.02	33.22	18.73	0.000

S = 212.208 **R-Sq = 97.8%** R-Sq(adj) = 97.5%

Analysis of Variance

Source	DF	SS	MS	F	P
Regression	1	15790538	15790538	350.65	0.000
Residual Error	8	360256	45032		
Total	9	16150794			

Unusual Observations

Obs	<i>E.coli</i> 0157:H7 Log CFU/0.1mL	CTCF-Fluorescence Intensity	Fit	SE Fit	Residual	St Resid
6	3.45	1707.8	2115.3	67.3	-407.6	-2.03R

R denotes an observation with a large standardized residual

Figure 9 Regression Analysis of dose response of *E.coli* 0157:H7 Log CFU/0.1mL and fluorescence intensity (CTCF) (created using Minitab® 16 Statistical Software)

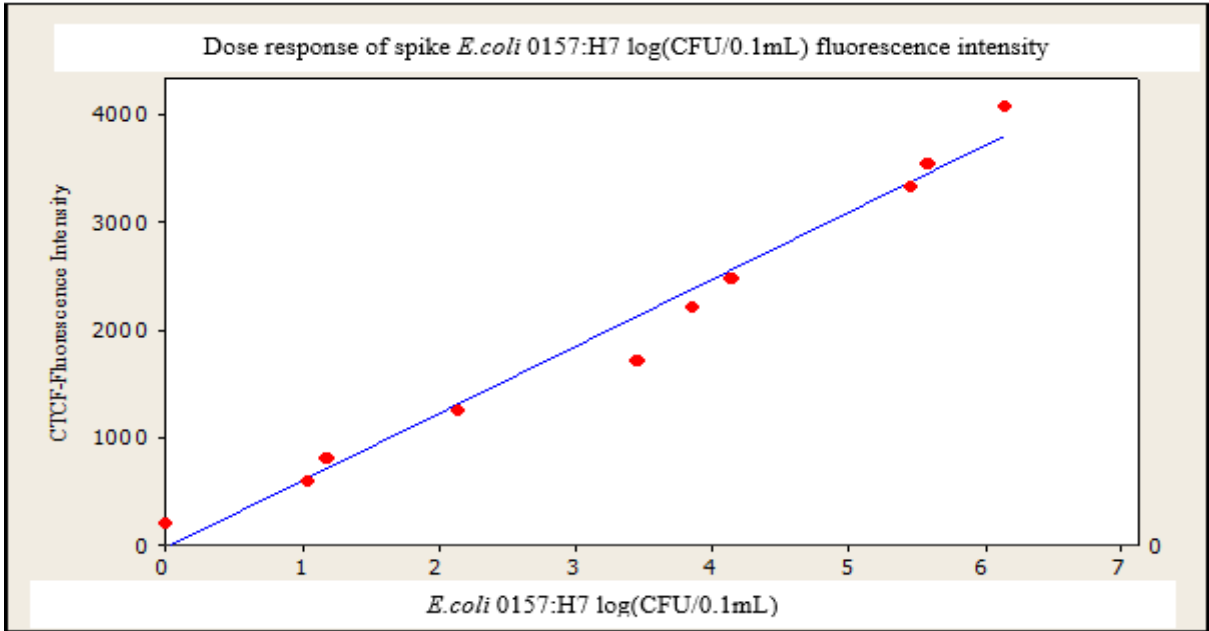

Figure 10 Dose response of spiked *E.coli* 0157:H7 log (CFU/0.1mL) and fluorescence intensity (created using Minitab® 16 Statistical Software)

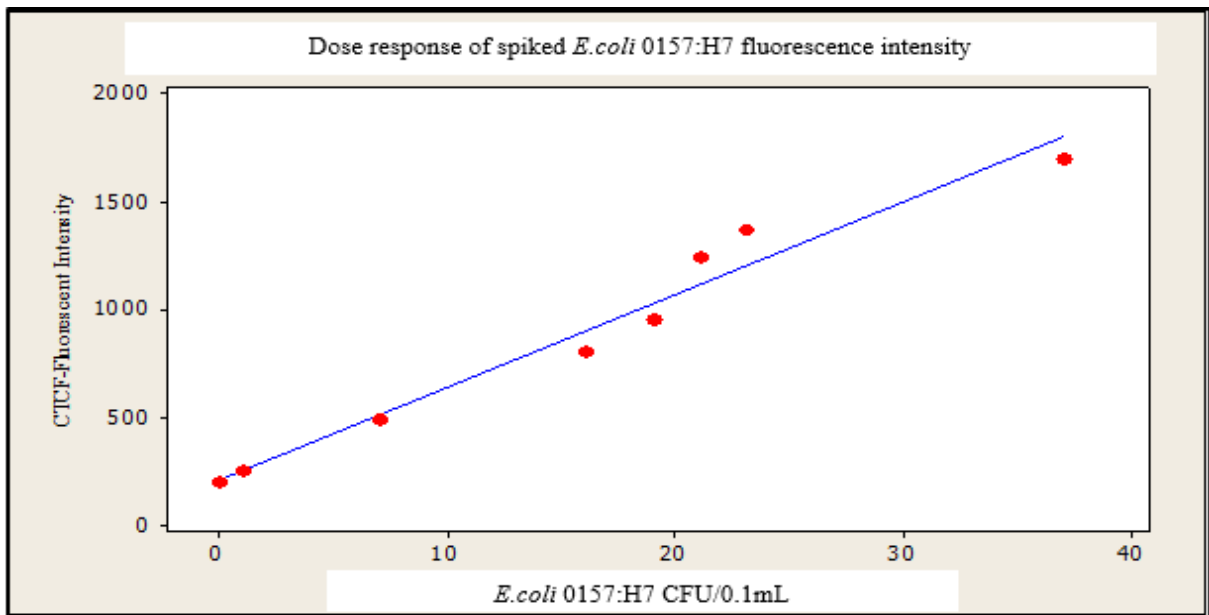

Figure 11 Dose response of spiked *E.coli* 0157:H7 CFU/0.1mL and fluorescence intensity (created using Minitab® 16 Statistical Software)

Descriptive Statistics: CTCF-Fluorescent Intensity

Variable	N	N*	Mean	SE Mean	StDev	Minimum	Q1	Median
CTCF-Fluorescence Intensity	10	0	775	168	532	200	245	654

Variable	Q3	Maximum
CTCF-Fluorescence Intensity	1282	1700

Minitab Regression Analysis: CTCF-Fluorescent versus *E.coli* 0157:H7 CFU/0.1mL

The regression equation is

CTCF-Fluorescence Intensity = 211 + 43.0 (*E.coli* 0157:H7 CFU/0.1mL)

Predictor	Coef	SE Coef	T	P
Constant	210.95	45.64	4.62	0.002
<i>E.coli</i> 0157:H7 CFU/0.1mL	43.026	2.611	16.48	0.000

S = 95.5365 **R-Sq = 97.1%** R-Sq(adj) = 96.8%

Analysis of Variance

Source	DF	SS	MS	F	P
Regression	1	2478601	2478601	271.56	0.000
Residual Error	8	73018	9127		
Total	9	2551618			

Figure 12 Regression Analysis of dose response of *E.coli* 0157:H7 CFU/0.1mL and fluorescence intensity (CTCF) (created using Minitab® 16 Statistical Software)

Descriptive Statistics: CTCF Fluorescence Intensity

Variable	N	N*	Mean	SE Mean	StDev	Minimum	Q1
CTCF Fluorescence Intensity	3	0	187.43	3.49	6.05	181.00	181.00

Variable	Median	Q3	Maximum
CTCF Fluorescence Intensity	188.30	193.00	193.00

Minitab Regression Analysis: CTCF Fluorescenc versus *E.aerogenes* CFU/0.1mL

The regression equation is

CTCF Fluorescence Intensity = 183 + 0.129 (*E.aerogenes* CFU/0.1mL)

Predictor	Coef	SE Coef	T	P
Constant	183.335	8.534	21.48	0.030
<i>E.aerogenes</i> CFU/0.1mL	0.1294	0.2325	0.56	0.677

S = 7.47220 **R-Sq = 23.6%** R-Sq(adj) = 0.0%

Analysis of Variance

Source	DF	SS	MS	F	P
Regression	1	17.29	17.29	0.31	0.677
Residual Error	1	55.83	55.83		
Total	2	73.13			

Figure 13 Regression Analysis of dose response of *E.aerogenes* CFU/0.1mL and fluorescence intensity (CTCF) (created using Minitab® 16 Statistical Software)

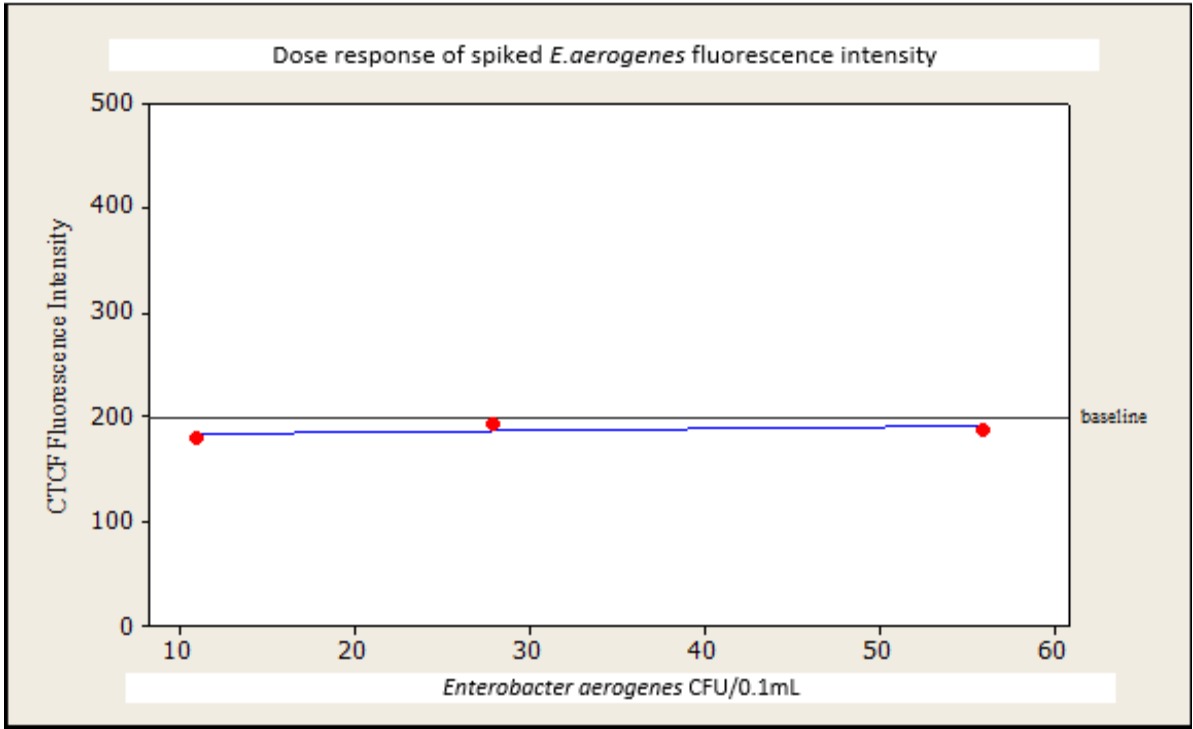

Figure 14 Dose response of spiked *E.aerogenes* CFU/0.1mL and fluorescence intensity
(created using Minitab® 16 Statistical Software)